



Plexus

Service & maintenance





Plexus

1.0 Installation

1.1 Product description

Plexus is provided with fixed lamellas which controls the primary air into non-parallel jets in a 360 degree air pattern. The 360 degree air pattern results in shorter air throws and a draft free indoor climate. Plexus can be used for both cooling, heating and ventilation. The possibilities are many and the flexibility large.

1.2 Handling

The beam must be handled with care, ensuring that the beam does not sustain dents, scratches or bends during installation.

Always seek to lift the beam at multiple points.

- Do not lift in pipes
- Do not lift in edges
- Each beam is equipped with protective film to avoid any damage during transport and handling at building site. The film needs to be removed before commissioning the products.

1.3 Mounting instruction

- Please visit www.lindqst.com
 - Select Documentation Finder
 - Select "Plexus"
 - Select "Mounting"

1.4 Air connection installation

The primary air supply should be connected with instructions from a ventilation specialist. Lindab's chilled beams can beneficially be used together with Lindab's Safe® duct systems.

1.5 Connection description water

Flow indication arrows are shown on the inlet and return pipes in order to assist the installer. If the beam has been ordered with integrated valves, a special direction of the flow must be upheld to ensure correct flow through the thermostatic valve. If the beam has been delivered without integrated valves, the flow can be reversed, depending on the location of the retrofitted valve. Please note the flow direction indicator on the valve to insure correct installation in relation to the desired flow.



Plexus

1.5.1 Push-on fittings

- Please ensure that all pipes and fittings are undamaged, as even small dents and scratches potentially pose a risk of leakage in the system. Always remember to do a pressure test after assembly of the pipe work.
- Both flow and return pipe is covered by a plastic or rubber protection cover, which should be removed before installation.



After removing the protection cover, make sure that the pipe is intact and undamaged, especially at the pipe end. Crooked or in other ways imperfect pipe ends will result in leaks. Deburr the pipe on the inside and the outside, using a deburring tool before installation



- Mount a push-on fitting to the pipe. Make sure to press the fitting all the way onto the pipe. Consult the installation guide for the specific fitting for further details on proper installation.

Push-on fitting





Plexus

Push-on valve



Notice! The connection pipes are internally soft-welded why it's not allowed to solder the beam to the pipes.

1.5.2 Compression fitting

- Please ensure that all pipes and fittings are undamaged, as even small dents and scratches potentially pose a risk of leakage in the system. Always remember to do a pressure test after assembly of the pipe work.
- While mounting a compression fitting, the pipe will be exposed to a big amount of force, creating a risk of crushing the pipe. To ensure that the pipe won't be crushed when mounting the compression fitting, a copper insert should be inserted into the pipe.
- Both flow and return pipe is covered by a plastic or rubber protection cover during transport, which must be removed before installation.



- After removing the protection cover, make sure that the pipe is intact and undamaged, especially at the pipe end. Crooked or in other ways imperfect pipe ends will result in leaks. Deburr the pipe on the inside and the outside, using a deburring tool before installation





Plexus

- The copper insert should be placed inside the pipe on the beam. Always support the copper pipe coil when inserting the copper insert into position.



- Mount a compression coupling and/or a valve to the pipe. Don't stress the nut too much, since this may crush the pipe.



Notice! The connection pipes are internally soft-welded why it's not allowed to solder the beam to the pipes.

1.5.3 Flex hoses

Our flexible hoses can be used with both compression and Tectite fitting. We recommend using Tectite fittings, for easier and faster mounting.

- Please ensure that all pipes and fittings are undamaged, as even small dents and scratches potentially pose a risk of leakage in the system. Always remember to do a pressure test after assembly of the pipe work.
- Both flow and return pipe is covered by a plastic or rubber protection cover, which should be removed before installation.





Plexus

After removing the protection cover, make sure that the pipe is intact and undamaged, especially at the pipe end. Crooked or in other ways imperfect pipe ends will result in leaks. Deburr the pipe on the inside and the outside, using a deburring tool before installation



- Mount a push-on fitting to the pipe. Make sure to press the fitting all the way onto the pipe. After mounting the push-on fitting, mount the flexible hose. Make sure that the flexible hose is pushed fully into the fitting. Consult the installation guide for the specific fitting for further details on proper installation.

Push-on fitting



Push-on valve



Notice! The connection pipes are internally soft-welded why it's not allowed to solder the beam to the pipes.



Plexus

2.0 Commissioning

2.1 Product labeling



Plexus I Fig.1: Label location exterior (Air connection end), Fig.2: Label location interior (On faceplate, water connection end). **Plexus F** Fig.1: Label location exterior (On plastic wrapping), Fig.2: Label location interior (On faceplate, water connection end). **Plexus F** Fig.1: Label location exterior (On delivery package), Fig.2: Label location interior (Inside air outlet).

On the label you'll find:

- Order: Order identification number.
- Pos: Order position.
- Product: Product configuration.
- Project: Project name.
- Mark: Marking noted on order.
- Nozzles: Number of nozzles.
- Plugs: Number of plugged nozzles.
- Product ID: Product number.
- Sign: To be signed when checked and commissioned on site.

Order: Ordernumber	
Pos: 10	
Product 0,00 m	
Pressure: Pa	Flow: l/s
Project: Project	
Mark: Mark	
Nozzels: 999 Plugs	Sign: _____
Product ID: 8 011-10-1	
	

2.2 Measure air pressure and calculating the airflow.

Before calculating the airflow, the static nozzle pressure must first be measured. The static nozzle pressure is the air pressure available at the nozzles.



Plexus

2.2.1 Measure the static nozzle pressure.

- To measure the air pressure, a manometer, analog or digital (such as the Lindab PC410) will be needed.
- Insert the measuring tube onto the specialized measuring nozzle

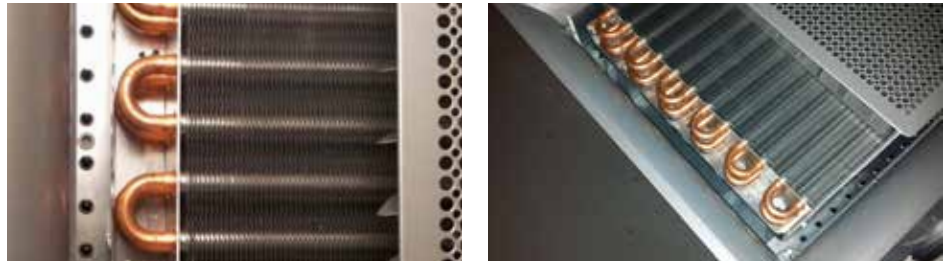

- Read off the static nozzle pressure from the manometer

2.2.2 Calculating the airflow

- After measuring the static nozzle pressure, read the setting of the four pins in the corners to find the mean value of the pins.
- Locate the diagram on the faceplate or see diagram 1, and use the static nozzle pressure and the mean value of the pins to find the current airflow.

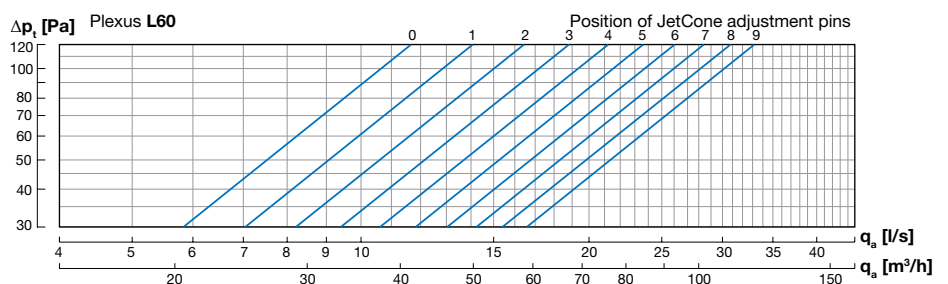
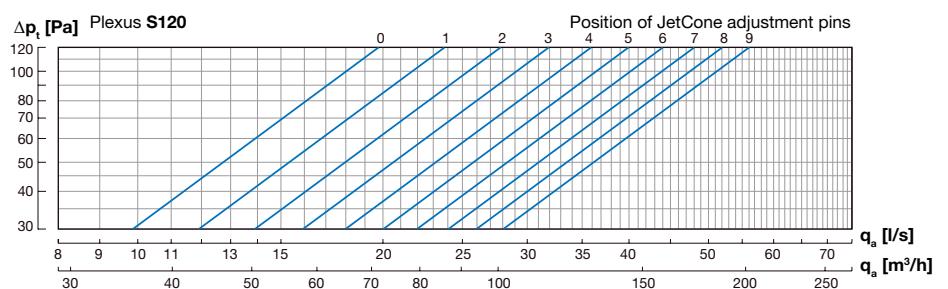
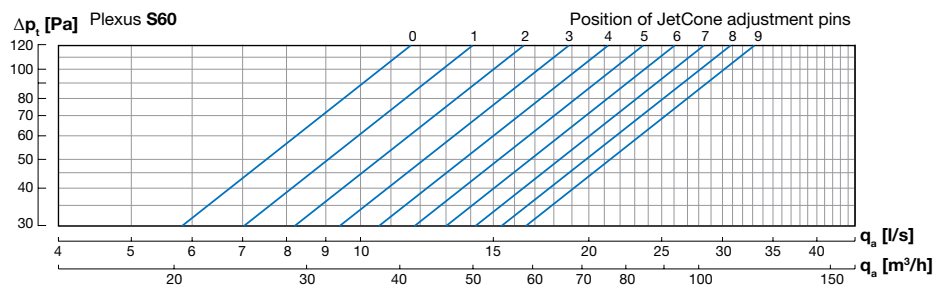



Plexus

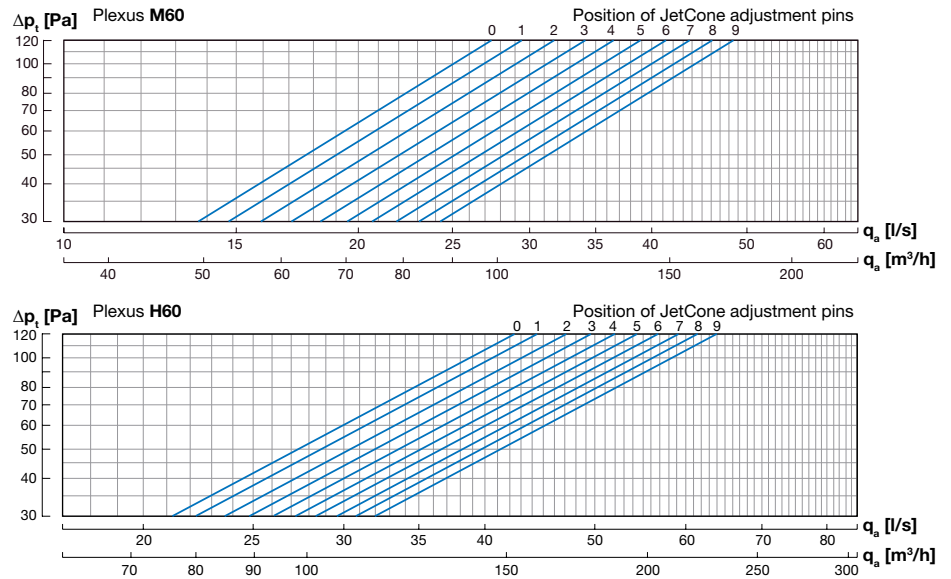

2.3 Changing the airflow

- Measure the static nozzle pressure
- Locate the air pressure/airflow diagram on the faceplate, or see diagram 1.
- Find the mean value of the four pins to reach the desired airflow, in the diagram on the faceplate. Use the static nozzle pressure and the desired airflow to find the mean value of the four pins.
- Adjust the four pins in the corners, so the mean value of the pins will correspond with the mean value found in the diagram.
- Example: Pin setting: $6+6+8+8 = 28 / 4 = \text{mean value } 7$.



Plexus

3.0 Maintenance

3.0 Maintenance

The interval of cleaning depends on the indoor environment where the beam is placed. Under optimal conditions the Plexus beams only need cleaning every 5 years.

3.1 Cleaning instructions

- Remove the faceplate
- Clean underneath the battery with a vacuum cleaner and a piece of wet cloth
- Only use lukewarm water and a mild detergent.

3.2 Models with down fold battery

- Remove the faceplate
- Unscrew the four screws on the battery, as described in the mounting instruction. Note that the two screws closest to the battery connection pipes must not be completely unscrewed. Refer to the mounting instruction for details on this matter.
- It is now possible to fold the battery down.

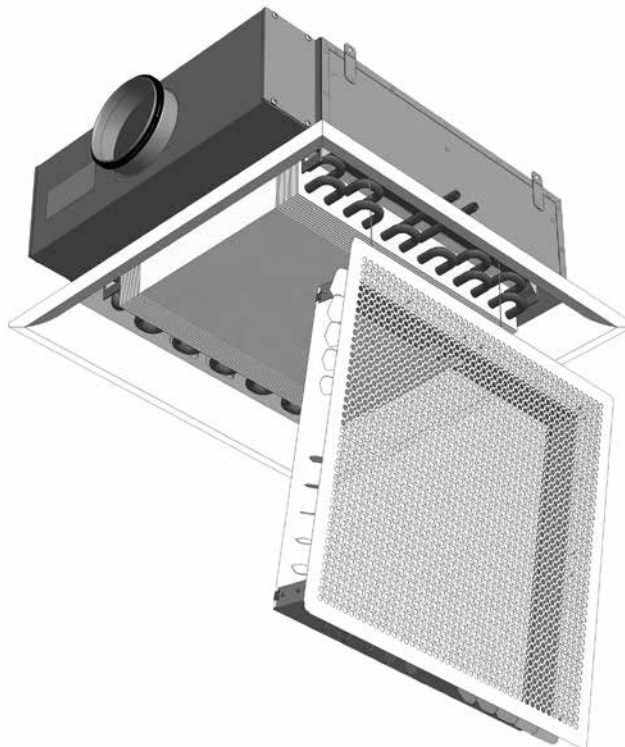



Plexus

4.0 Product and system specification

4.1 Material data

	Plexus I 60	Plexus I 120	Plexus F 60	Plexus F 120
Weight, kg/st	11.6	21.4	17.2	31.7
Water content, cooling, l/m	0.83	2.08	0.83	2.08
Water content, heating, l/m	0.17	0.41	0.17	0.41
Water content, cooling only, l/m	1.0	2.5	1.0	2.5
Copper pipes, quality	EN 12735-2 CU-DHP	EN 12735-2 CU-DHP	EN 12735-2 CU-DHP	EN 12735-2 CU-DHP
Pressure class	PN10	PN10	PN10	PN10

4.2 Environmental declaration

- Please visit www.lindqst.com
 - Select Documentation Finder
 - Select "Plexus"
 - Select "Environmental declaration"

4.3 Working and test pressure

- Lindab's waterborne products have been manufactured and tested according to the Pressure Equipment Directive 97/237EC. The products are classified as SEP – Sound Engineering Practice.

- Pressure table

Pressure class	PN10
Max. working pressure	10 bar
Max. recommended dynamic pressure	0,2 bar
Max. test pressure	16 bar

- Even though the battery of the chilled beam can withstand a very high static working pressure, we recommend a much lower dynamic working pressure, to avoid noise issues from the valves.



Plexus

4.4 Water quality

- The water preparation and maintenance for the chilled beam water circuit should be handled by a specialist
- To prevent corrosion, the water circuit must be airtight
- The water system must also be equipped with aerators to remove any build-up air in the system.
- The water should be oxygen free, to prevent corrosion.
- The water system must be filled with potable water that complies with the “EC directive 98/83/EC”.
- pH value of water must be between approximately 6-9 pH
- The water velocities should not exceed 1m/s, and should be kept as close to the nominal flow as possible to minimize noise and optimize the energy yield
- There should be used in-line strainers to remove dirt particles from the water.
- If the water contains any additive inhibitor this must be appropriate to use with copper and solder.

4.5 Air quality

- Primary supply air should be clean and filtered before reaching the beam.

4.6 Capacity test

- Lindabs active chilled beams are Eurovent-certified and tested according to EN-15116.



Support
Hjælp
Hjälp
Tuotetuki
Unterstützung
Supporto

UK - Here you can find product updates/mounting instructions and support telephone number/mail.

www.lindab.com

Right to alterations reserved.

DK - Her kan du finde seneste produkt opdateringer/montagevejledninger samt support tlf. nr/mail.

www.lindab.dk

Ret til ændringer forbeholdes.

SE - Här kan du alltid hitta senaste produktuppdateringarna/montageanvisningarna samt support tel. /e-mail.

www.lindab.se

Rätt till ändringar förbehålles.

FI - Täältä löydät uusimmat tuotetiedot ja asennusohjeet sekä tuotetuen yhteystiedot.

www.lindab.fi

Oikeus muutoksiin pidätetään.

DE - Hier finden Sie aktuelle Produktinformationen/ Montageanleitungen und Telefonnummer/ E-Mail-Adressen der Ansprechpartner.

www.lindab.de

Änderungen vorbehalten.

IT - Qui potete trovare istruzioni di montaggio, informazioni sul prodotto ed un supporto tecnico qualificato
Tel. 011 9952099 - e-mail: lindab@lindab.it

www.lindab.it

Soggetto a modifica senza obbligo di preavviso.

FR - Vous trouverez les fiches produits ou de montage actualisées ainsi que les coordonnées du support téléphonique à l'adresse suivante :

www.lindab.fr

Toutes modifications réservées.

**Do you have trouble finding your local contacts
please go to:**

www.lindab.com

Plexus-03052013



www.lindab.com