



INTEGRA

Installation instruction
Installations vejledning
Montageanvisning
Asennusohje
Montageanweisung
Istruzioni di montaggio
Instructions de montage

PC6



PC7



NC19



RC14



RC15



RCG



LCC



LCP



LKP











Integra

Contents	Symbols / Symboler / Symbolit / Symbole / Simboli / Symboles.....	2
Indhold	PC6.....	3
Innehållsförteckning	PC7.....	4
Sisällysluettelo	RC14.....	5
Inhalt	RC15.....	6
Sommario	NC19.....	7
Sommaire	RCG.....	8
	LCC.....	10
	LCP/LKP.....	11
	Accessories - Order code / Tilbehør - Bestillings kode / Tillbehör - Beställningskod / Lisävarusteet - Tilaukoodi / Zubehör - Bestellcode / accessori - Ordinanze / Accessoires - codification.....	12
	Ceiling systems / Loftsystemer / Undertakssystem / Kattojärjestelmät / Deckensysteme / Sistemi modulari di controsoffitto / Systèmes de plafond.....	24

Maintenance	UK - The diffuser can be demounted and vacuum cleaned by using a smooth nozzle brush or wiped off by using a sponge or wiped off with a clean damp sponge or soft cotton cloth.
Vedligeholdelse	DK - Diffusoren kan demonteres og støvsuges med et blødt børstestykke eller aftørres med en fugtig klud.
Underhåll	SE - Donet kan demonteras och dammsugas med ett mjukt borstmunstycke eller torkas av med en fuktig trasa.
Huolto	FI - Laite voidaan puhdistaa imurilla käyttäen pehmeää harjaosaa tai se voidaan pyyhkiä kostutetulla kangasliinalla.
Wartung	DE - Der Durchlass kann zur Reinigung demontiert werden. Die Reinigung erfolgt entweder mit einem Staubsauger mit einer weichen Düsenbürste oder mit einem weichen Baumwolltuch, das in klares Wasser getaucht und gut ausgewrungen wurde.
Manutenzione	IT - Il diffusore può essere pulito con una spazzola morbida oppure con una spugna o un panno di cotone leggermente umidi.
Entretien	FR - Le diffuseur peut être démonté et nettoyé avec une brosse d'aspirateur, une éponge propre ou un chiffon humide doux en coton.

Symbols Symboler Symboler Symbolit Symbole Simboli Symboles		Supply air Indblæsning Tilluft Tuloilma Zuluft Aria di mandata Soufflage		Exhaust air Udsugning Frånluft Poistoilma Abluft Aria di estrazione Extraction		Low impulse principle Lavimpulsprincip Lågimpulsprincip Piennopeuspuhallus Niedrigimpulslüftung Ventilazione a basso impulso Principe de Basse vitesse	
			Open / closed damper Åbent / lukket spjæld Öppet / Stängt spjäll Säätöpelti auki / kiinni Geöffnete / Geschlossene Drossel Serranda aperta / chiusa Registre ouvert / fermé				No tools - Magnet Ingen værktøj - Magnet Inga verktyg - Magnet Ei työkaluja - Magneetit Keine Werkzeuge - Magnet Nessun attrezzo - Magnete Sans outil - Aimants



Integra

PC6

Measure/weight
Mål/vægt
Mått/vikt
Mitta/paino
Abmessungen/Gewicht
Misura/peso
Dimensions / poids

PC6

Ød mm	ØA mm	H mm	ØU mm	kg
125	360	140	370	3.9
160	460	140	470	5.3
200	460	140	470	5.4
250	540	140	550	7.4
315*	540	140	550	8.1

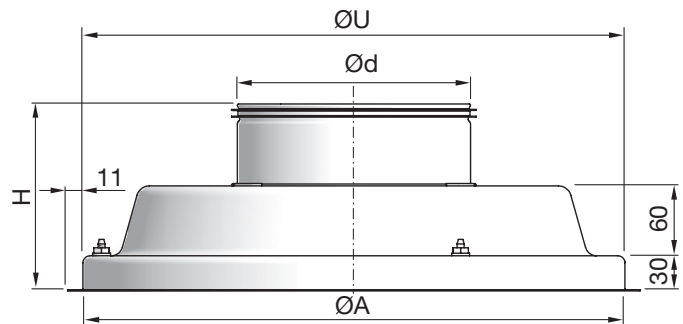

* UK - Ød 315 page 15
DK - Ød 315 side 15
SE - Ød 315 sida 15
FI - Ød 315 sivu 15

* DE - Ød 315 Seite 15
IT - Ød 315 pagina 15
FR - Ød 315 page 15

UK- ØU = Ceiling grid opening
DK- ØU = Loft udkæring
SE - ØU = Håltagning
FI - ØU = Asennusaukko

DE - ØU = Aussparung
IT - ØU = Dimensione del foro
FR - ØU = Overture dans le plafond

Service wires
Service wirer
Service vajror
Huoltovaijerit
Service Drähte
Cavi per manutenzione
Câbles de maintien



No tools - Magnet
Ingen værktøj - Magnet
Inga verktyg - Magnet
Ei työkaluja - Magneetit
Keine Werkzeuge - Magnet
Nessun attrezzo - Magnete
Sans outil - Aimants

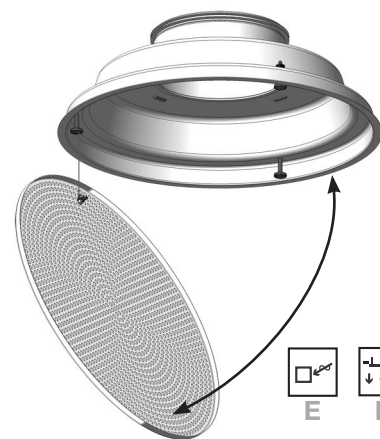
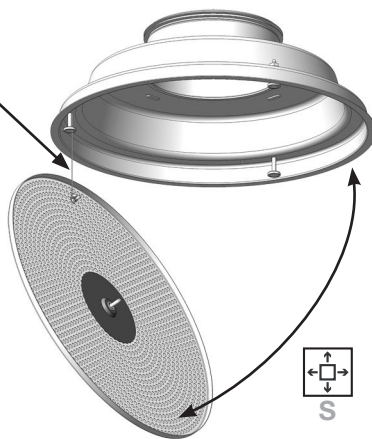

Order code
Ordre kode
Beställningskod
Tuotekoodi
Bestellcode
Codice d'ordine
Codification

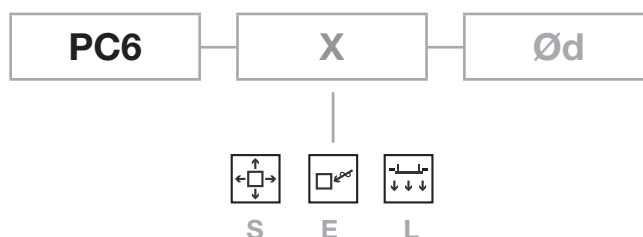



Integra

PC7

Measure/weight
Mål/vægt
Mått/vikt
Mitta/paino
Abmessungen/Gewicht
Misura/peso
Dimensions / poids

PC7

Ød mm	ØA mm	H mm	ØU mm	kg
160	460	140	470	5.3
200	460	140	470	5.4
250	540	140	550	7.4
315*	540	140	550	8.1

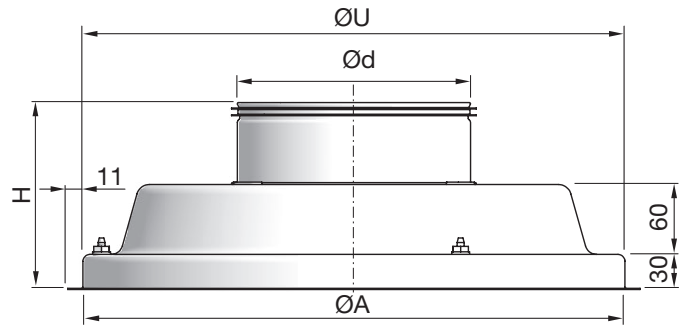

!

* UK - Ød 315 page 15 * DE - Ød 315 Seite 15
 DK - Ød 315 side 15 IT - Ød 315 pagina 15
 SE - Ød 315 sida 15 FR - Ød 315 page 15
 FI - Ød 315 sivu 15

UK- ØU = Ceiling grid opening DE - ØU = Aussparung
 DK- ØU = Loft udskæring IT - ØU = Dimensione del foro
 SE - ØU = Håltagning FR - ØU = Overture dans le plafond
 FI - ØU = Asennusaukko

Service wires
Service wirer
Service vajror
Huoltovaijerit
Service Drähte
Cavi per manutenzione
Câbles de maintien

No tools - Magnet
 Ingen værktøj - Magnet
 Inga verktyg - Magnet
 Ei työkaluja - Magneetit
 Keine Werkzeuge - Magnet
 Nessun attrezzo - Magnete
 Sans outil - Aimants

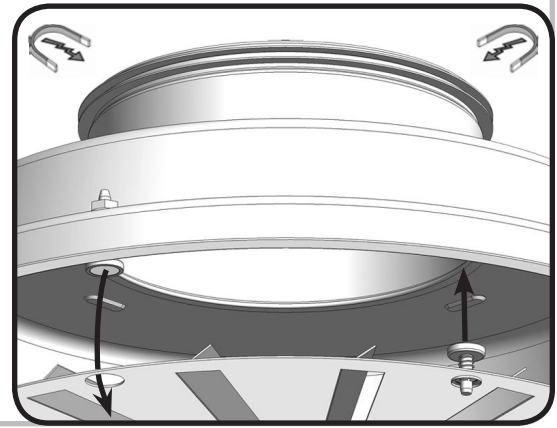
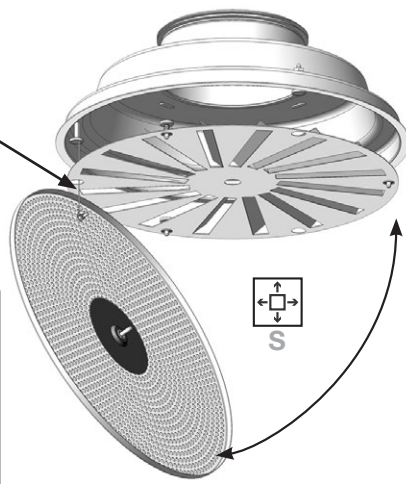

Order code
Ordre kode
Beställningskod
Tuotekoodi
Bestellcode
Codice d'ordine
Codification

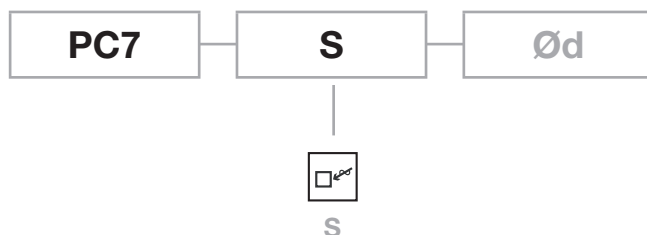



Integra

RC14

Measure/weight
Mål/vægt
Mått/vikt
Mitta/paino
Abmessungen/Gewicht
Misure/peso
Dimensions / poids

RC14

Ød mm	ØA mm	H mm	ØU mm	kg
160	360	140	370	5.3
200	360	140	370	5.4
250	460	140	470	7.4
315*	540	140	550	8.1

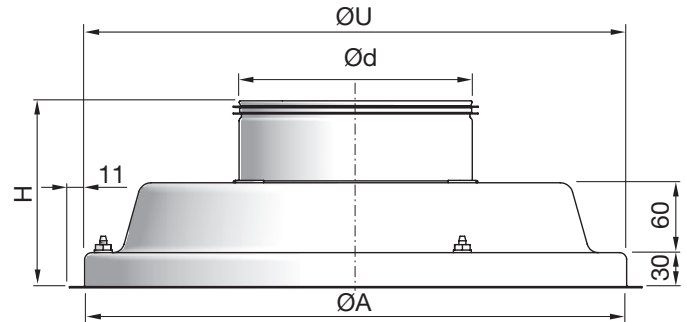

!

* UK - Ød 315 page 15 * DE - Ød 315 Seite 15
 DK - Ød 315 side 15 IT - Ød 315 pagina 15
 SE - Ød 315 sida 15 FR - Ød 315 page 15
 FI - Ød 315 sivu 15

UK- ØU = Ceiling grid opening DE - ØU = Aussparung
 DK- ØU = Loft udskæring IT - ØU = Dimensione del foro
 SE - ØU = Håltagning FR - ØU = Overture dans le plafond
 FI - ØU = Asennusaukko

Service wires
Service wirer
Service vajror
Huoltovaijerit
Service Drähte
Cavi per manutenzione
Câbles de maintien

 No tools - Magnet
 Ingen værktøj - Magnet
 Inga verktyg - Magnet
 Ei työkaluja - Magneetit
 Keine Werkzeuge - Magnet
 Nessun attrezzo - Magnete
 Sans outil - Aimants

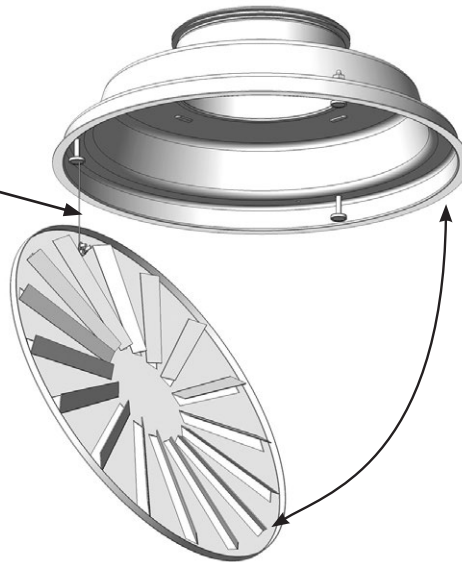

Order code
Ordre code
Beställningskod
Tuotekoodi
Bestellcode
Codice d'ordine
Codification

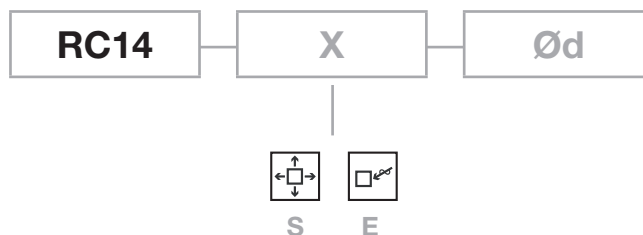



Integra

RC15

Measure/weight
Mål/vægt
Mått/vikt
Mitta/paino
Abmessungen/Gewicht
Misure/peso
Dimensions / poids

RC15

Ød mm	ØA mm	H mm	ØU mm	kg
160	360	140	370	5.3
200	360	140	370	5.4
250	460	140	470	7.4
315*	540	140	550	8.1

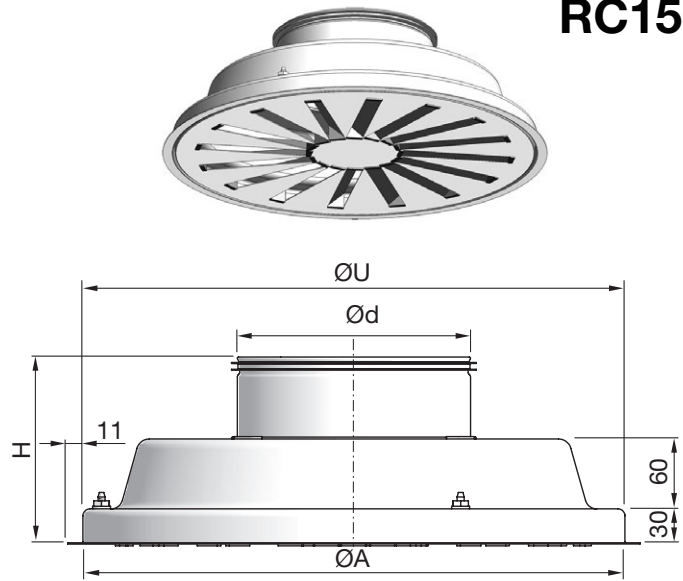

!

* UK - Ød 315 page 15
DK - Ød 315 side 15
SE - Ød 315 sida 15
FI - Ød 315 sivu 15

* DE - Ød 315 Seite 15
IT - Ød 315 pagina 15
FR - Ød 315 page 15

UK- ØU = Ceiling grid opening
DK- ØU = Loft udkæring
SE- ØU = Håttagning
FI - ØU = Asennusaukko

DE - ØU = Aussparung
IT - ØU = Dimensione del foro
FR - ØU = Overture dans le plafond

Service wires
Service wirer
Service vajror
Huoltovaijerit
Service Drähte
Cavi per manutenzione
Câbles de maintien

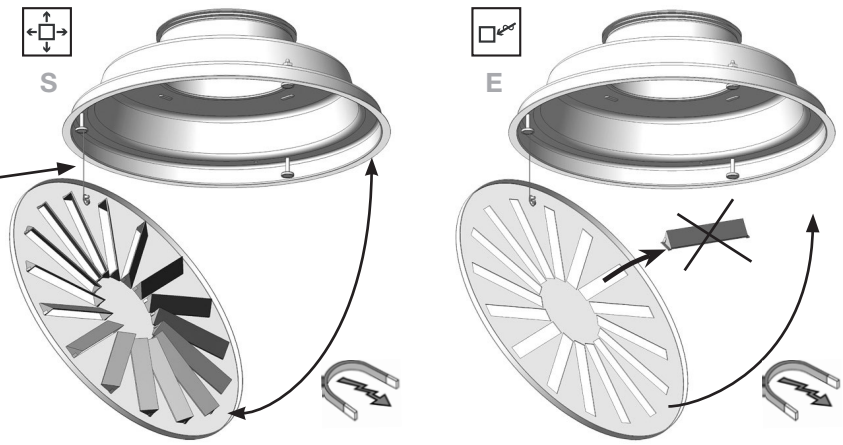

<p>Standard - Inward swirl Standard - Indadvendt rotation Standard - Inåtvänd rotation Standard - Pyörrehajotin sisääpäin Standard - Innendrall Standard - Rotazione verso l'interno Standard - Rotation intérieure</p>	<p>Standard - Outward swirl Standard - Udadvendt rotation Standard - Utåtvänd rotation Standard - Pyörrehajotin ulospäin Standard - Außendrall Standard - Rotazione verso l'esterno Standard - Rotation extérieure</p>	<p>Standard - Vertical supply air Standard - Vertikal Indblæsning Standard - Vertikal inblåsning Standard - Pystysuora puhallus Standard - Vertikale Luftzufuhr Standard - Immissione dell'aria in direzione verticale Standard - Soufflage vertical</p>
--	---	---

Order code
Ordre kode
Beställningskod
Tuotekoodi
Bestellcode
Codice d'ordine
Codification

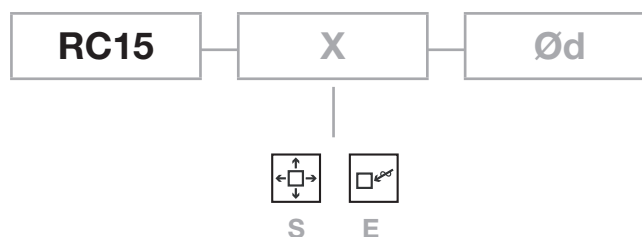



Integra

NC19

Measure/weight
Mål/vægt
Mått/vikt
Mitta/paino
Abmessungen/Gewicht
Misura/peso
Dimensions / poids

NC19

Ød mm	ØA mm	H mm	ØU mm	kg
125	360	140	370	3.9
160	460	140	470	5.3
200	460	140	470	5.4
250	540	140	550	7.4
315*	540	140	550	8.1



UK- ØU = Ceiling grid opening
DK- ØU = Loft udkæring
SE- ØU = Håtagning
FI - ØU = Asennusaukko
DE - ØU = Aussparung
IT - ØU = Dimensione del foro
FR - ØU = Overture dans le plafond



* UK - Ød 315 page 15
DK - Ød 315 side 15
SE - Ød 315 sida 15
FI - Ød 315 sivu 15
* DE - Ød 315 Seite 15
IT - Ød 315 pagina 15
FR - Ød 315 page 15

Service wires
Service wirer
Service vajror
Huoltovaijerit
Service Drähte
Cavi per manutenzione
Câbles de maintien

No tools - Magnet
Ingen værktøj - Magnet
Inga verktyg - Magnet
Ei työkaluja - Magneetit
Keine Werkzeuge - Magnet
Nessun attrezzo - Magnete
Sans outil - Aimants

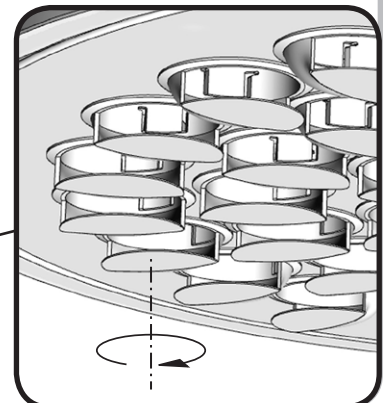
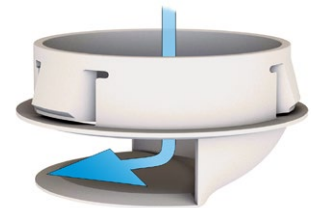

Order code
Ordre kode
Beställningskod
Tuotekoodi
Bestellcode
Codice d'ordine
Codification

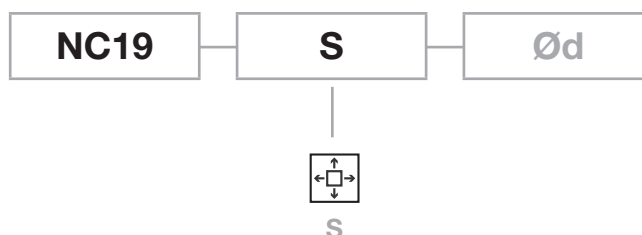



Integra

RCG

Measure/weight
Mål/vægt
Mått/vikt
Mitta/paino
Abmessungen/Gewicht
Misura/peso
Dimensions / poids

RCG

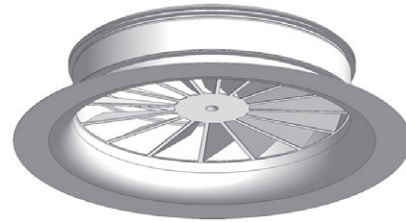

Ød mm	ØD mm	H mm	ØU mm	kg
125	200	65	150	0.4
160	250	65	200	0.5
200	300	65	250	0.6
250	350	85	300	0.8
315	450	100	400	1.0
400	570	95	500	1.5

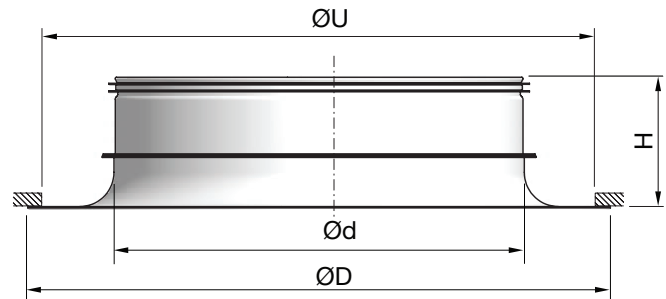

UK- ØU = Ceiling grid opening
DK- ØU = Loft udskæring
SE- ØU = Håltagning
FI - ØU = Asennusaukko
DE - ØU = Aussparung
IT - ØU = Dimensione del foro
FR - ØU = Overture dans le plafond

Order code
Ordre kode
Beställningskod
Tuotekoodi
Bestellcode
Codice d'ordine
Codification



Accessories - GRZ1
Tilbehør - GRZ1
Tillbehör - GRZ1
Lisävarusteet - GRZ1
Zubehör - GRZ1
Accessori - GRZ1
Accessoires - GRZ1

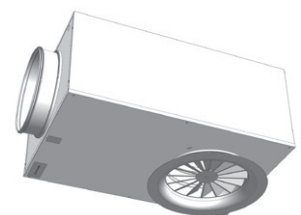
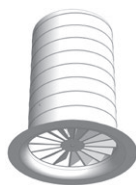

RCG + duct
RCG + kanal
RCG + kanal
RCG + kanava
RCG + Rohr
RCG + Canale
RCG + Conduit

RCG + MBB

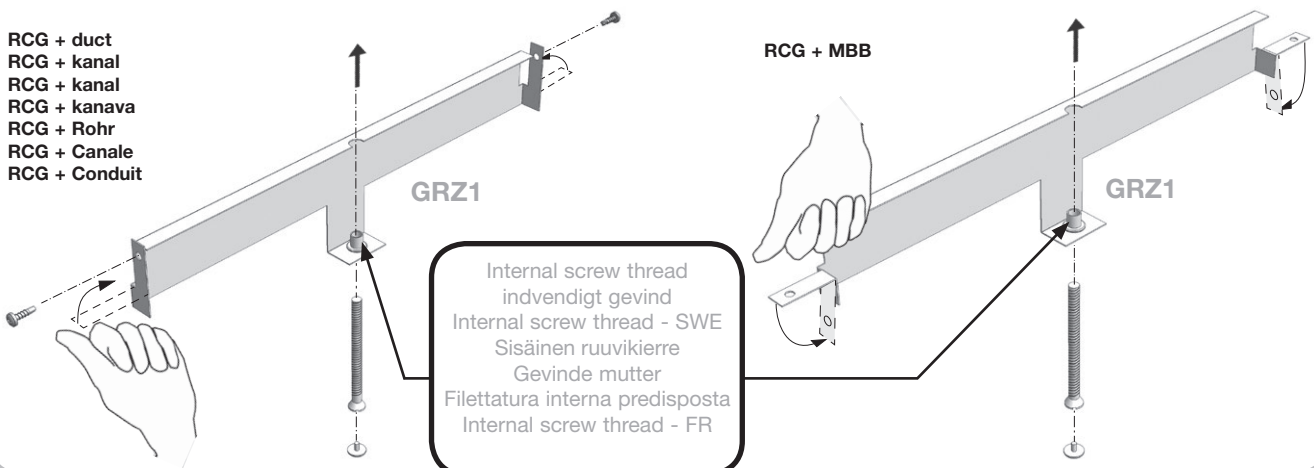

GRZ1

GRZ1

Internal screw thread
indvendigt gevind
Internal screw thread - SWE
Sisäinen ruuvikierre
Gevinde mutter
Filettatura interna predisposta
Internal screw thread - FR



Integra

RCG + GRZ1

Accessories GRZ1 Tilbehør GRZ1 Tillbehör GRZ1 Lisävarusteet GRZ1 Zubehör GRZ1 Accessori GRZ1 Accessoires GRZ1

- RCG + GRZ1 + duct
- RCG + GRZ1 + kanal
- RCG + GRZ1 + kanal
- RCG + GRZ1 + kanava
- RCG + GRZ1 + Rohr
- RCG + GRZ1 + Canale
- RCG + GRZ1 + Conduit

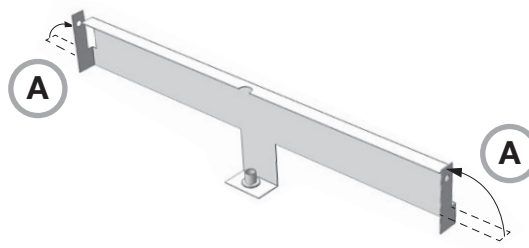
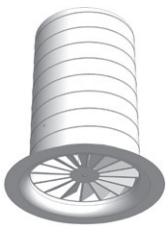
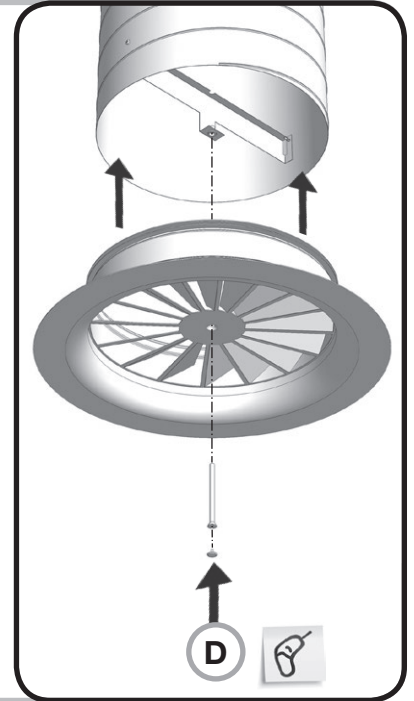
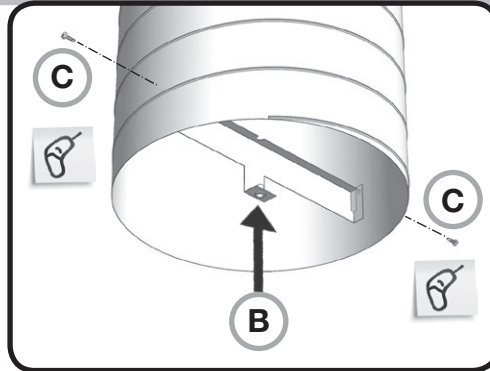

RCG + GRZ1 + MBB

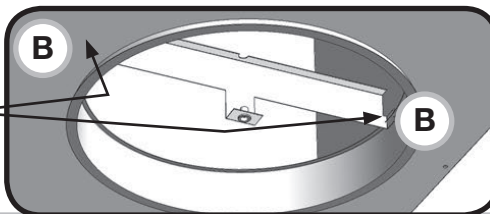
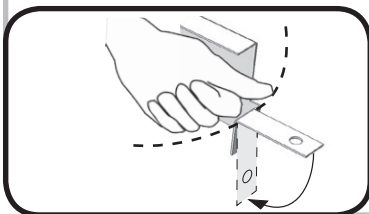
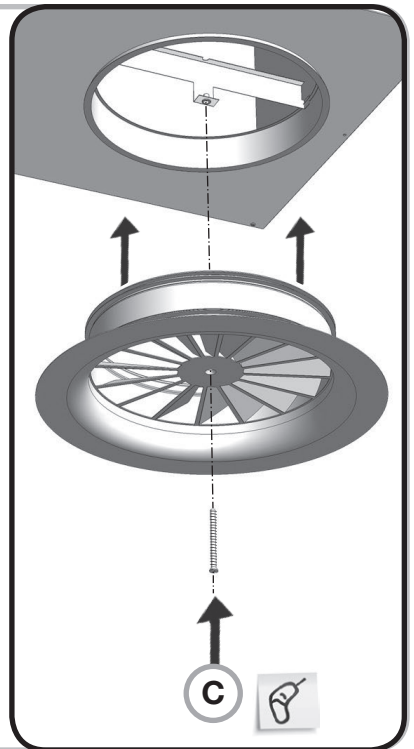
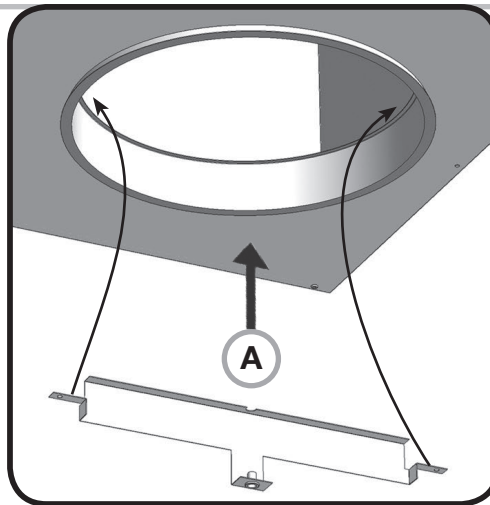
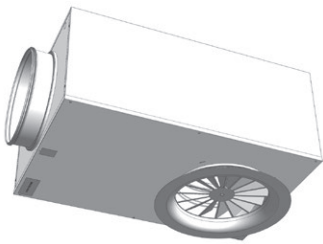

- GRZ1 Order code
- GRZ1 Ordre kode
- GRZ1 Beställningskod
- GRZ1 Tuotekoodi
- GRZ1 Bestellcode
- GRZ1 Codice d'ordine
- GRZ1 Codification

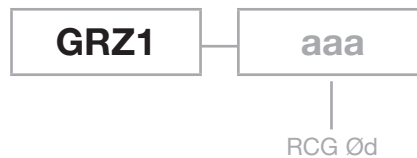



Integra

LCC

Measure/weight
Mål/vægt
Mått/vikt
Mitta/paino
Abmessungen/Gewicht
Misure/peso
Dimensions / poids

Ød mm	ØU mm	kg
125	525	1.3
160	525	1.5
200	525	2.3
250	525	3.4
315*	525	4.5

!

* UK - Ød 315 page 15
DK - Ød 315 side 15
SE - Ød 315 sida 15
FI - Ød 315 sivu 15

* DE - Ød 315 Seite 15
IT - Ød 315 pagina 15
FR - Ød 315 page 15

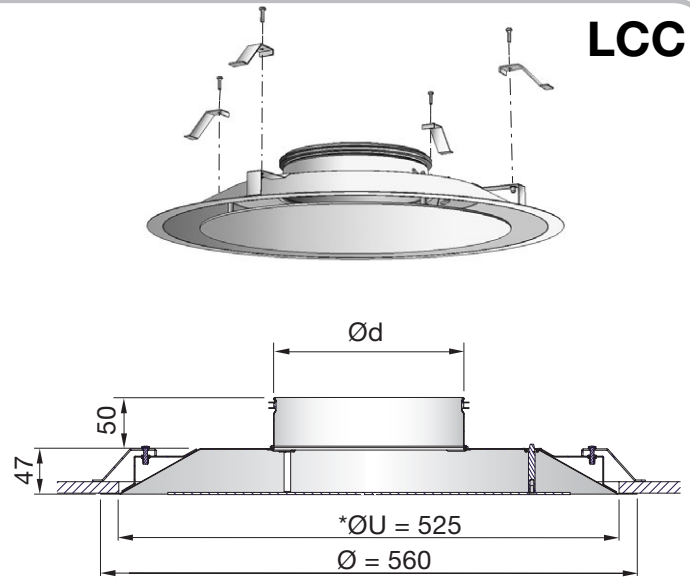

UK- ØU = Ceiling grid opening
DK- ØU = Loft udkæring
SE- ØU = Håtagning
FI - ØU = Asennusaukko

DE - ØU = Aussparung
IT - ØU = Dimensione del foro
FR - ØU = Overture dans le plafond

Brackets included
Beslag medfølger
Beslag medfølger
Kiinnikkeet sisältyvät
Klammern enthalten
Brackets included-IT
Brackets included-F

Service wires
Service wirer
Service vajror
Huoltovaijerit
Service Drähte
Cavi per manutenzione
Câbles de maintien

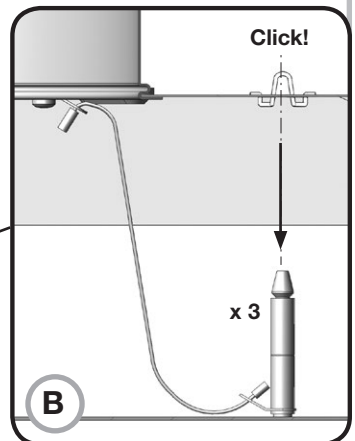
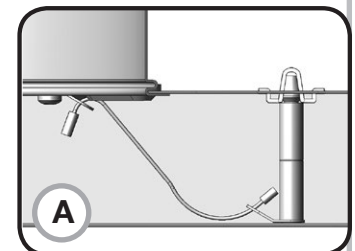
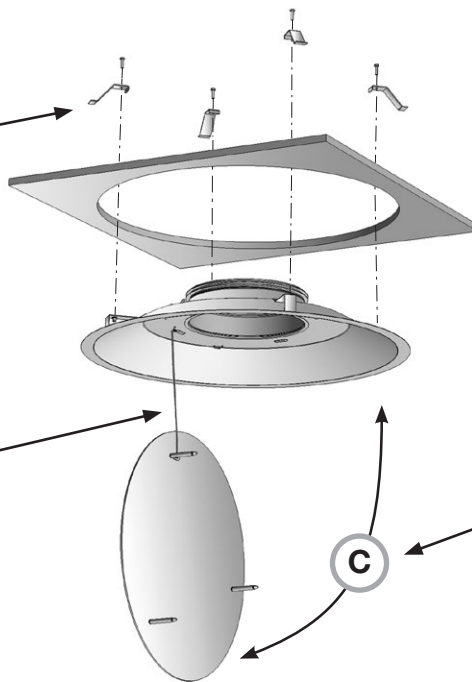

Order code
Ordre kode
Beställningskod
Tuotekoodi
Bestellcode
Codice d'ordine
Codification

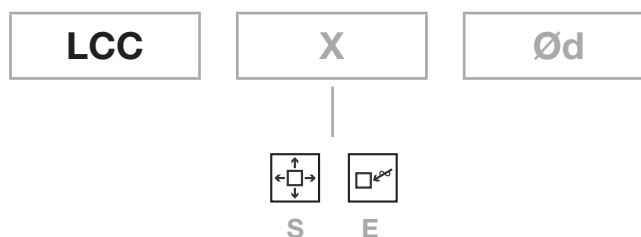



Integra

LCP / LKP

Measure/weight
Mål/vægt
Mått/vikt
Mitta/paino
Abmessungen/Gewicht
Misura/peso
Dimensions / poids

LCP

LKP

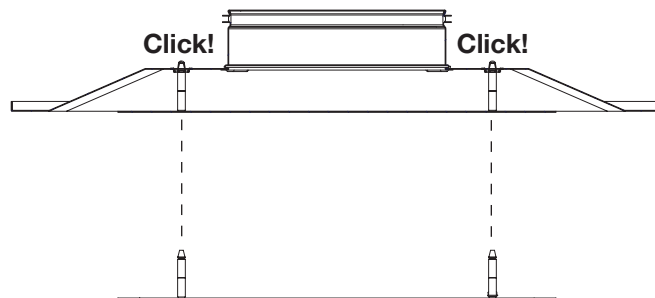

Ød mm	kg
125	3.2
160	3.2
200	3.3
250	3.4
315	3.5

!
UK - Upper part adapted to ceiling system
DK - Overpart tilpasses loftsystem
SE - Upper part adapted to ceiling system
FI - Ylempi osa sovitettu alakattoon
DE - Oberteil für Deckensystem angepasst
IT - Parte superiore adattata al controsoffitto
FR - Upper part adapted to ceiling system

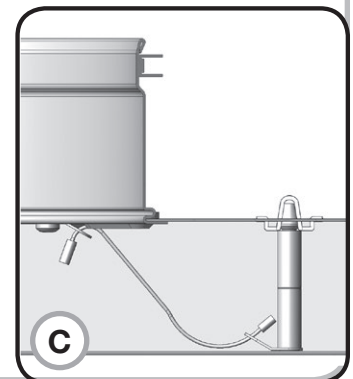
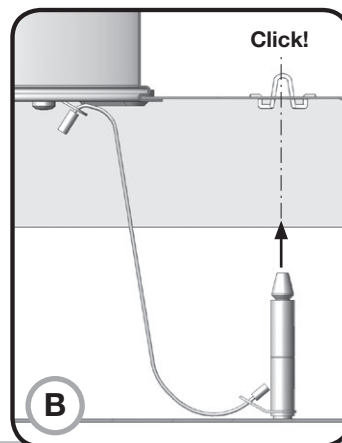
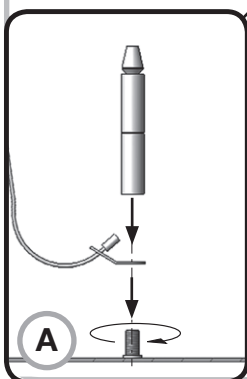
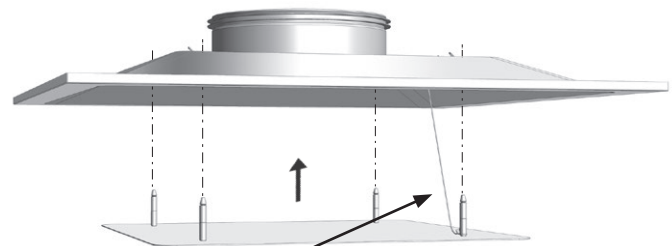
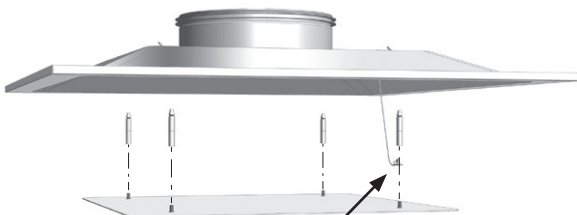

Order code
Ordre kode
Beställningskod
Tuotekoodi
Bestellcode
Codice d'ordine
Codification

LCP/LKP

Ød

bb

1-21

Ceiling system / Loftsystem / Undertakssystem
Kattojärjestelmät / Deckensysteme
Sistemi di controsoffitto / Type de plafond



Integra

Overview

Översigt

Överikt

Yleiskatsaus

Übersicht

Panoramica

Aperçu

Accessories / Order code
Tilbehør / Bestillings kode
Tillbehör / Beställningskod
Lisävarusteet / Tilauskoodi
Zubehör / Bestellbeispiel
Accessori / Ordinazione
Accessoires / Codification

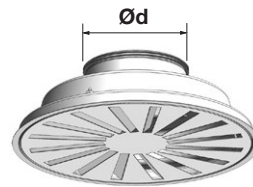

MBB

PC6, PC7, RC14,
RC15, NC19, RCG,
LCC, LCP, LKP

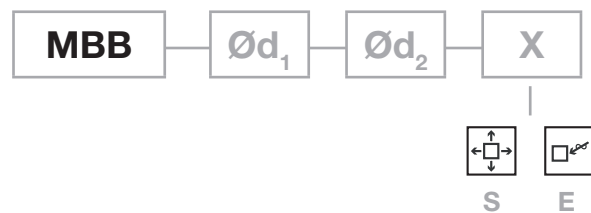
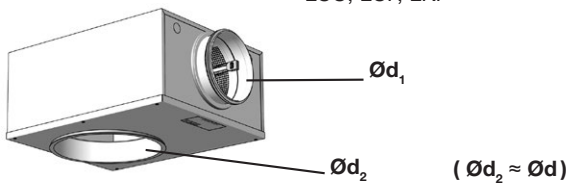

DCZ

PC6, PC7, RC14,
RC15, NC19

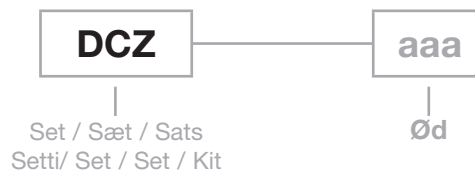
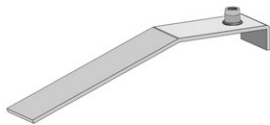

GRZ1

RCG

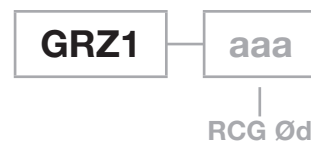

LM

PC6, PC7, RC14,
RC15, NC19, RCG

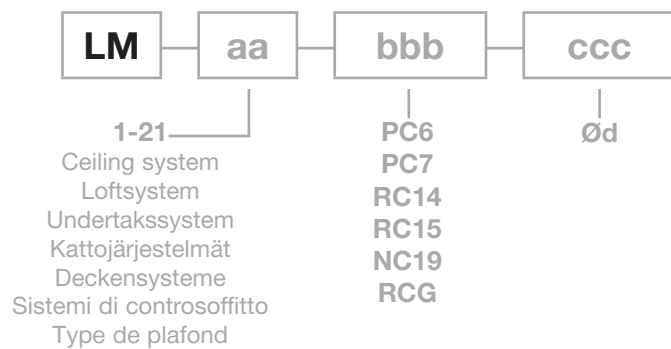
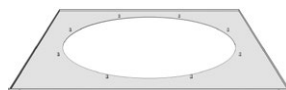



Integra

MBB

Accessories-MBB Tilbehør-MBB Tillbehör-MBB Lisävarusteet-MBB Zubehör-MBB Accessori-MBB Accessoires MBB

Accessories / Plenum box MBB
Tilbehør / Trykfordelingsboks MBB
Tillbehör / Tryckfördelningslåda MBB
Lisävarusteet / Liitäntälaatikko MBB
Zubehör / Anschlusskasten MBB
Accessori / Plenum MBB
Accessoires / Plénum MBB

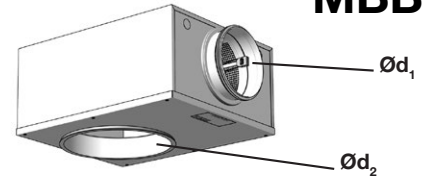
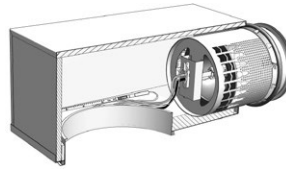

MBB

Damper
Spjæld
Spjäll
Säätöpelti
Drossel
Serranda
Registre

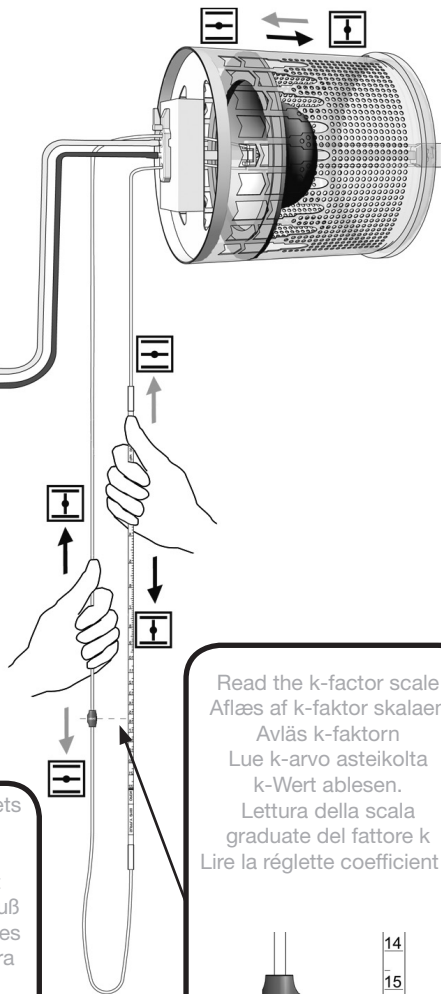

Measuring outlets
 Måleudtag
 Mätuttag
 Mittausyhteet
 Für den Anschluß
 eines Meßgerätes
 Punti per misura
 pressione
 Prises de pression

Read the k-factor scale
 Aflæs af k-faktor skalaen
 Avläs k-faktorn
 Lue k-arvo asteikolta
 k-Wert ablesen.
 Lettura della scala
 graduate del fattore k
 Lire la réglette coefficient k

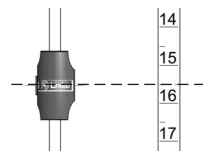

Dimensions
Dimensioner
Dimensioner
Mitat
Dimensionen
Dimensioni
Dimensions

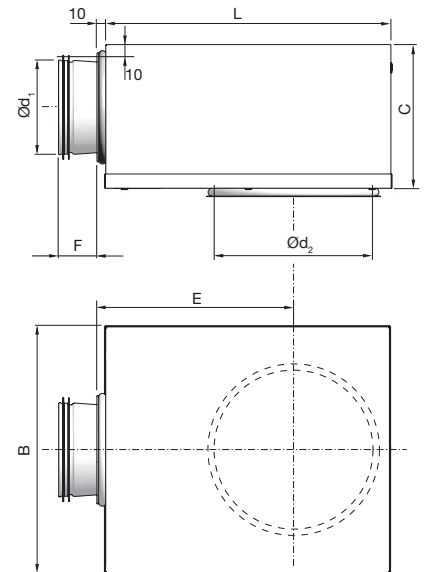

Ød ₁ mm	Ød ₂ mm	B mm	C mm	E mm	F mm	L mm	m kg
100	100	260	159	216	50	310	2,6
100	125	260	159	216	50	310	2,6
100	160	260	159	216	50	310	2,6
125	125	310	184	262	50	376	3,7
125	160	310	184	262	50	376	3,7
125	200	310	184	262	50	376	3,7
160	160	380	220	323	50	459	5,5
160	200	380	220	323	50	459	5,5
160	250	380	220	323	50	459	5,5
200	200	460	259	396	70	565	7,3
200	250	460	259	396	70	565	7,3
200	315	460	259	396	70	565	7,3
250	250	540	309	486	70	698	10,6
250	315	540	309	486	70	698	10,6
250	400	540	309	486	70	698	10,6
315	315	540	373	646	70	858	13,5
315	400	540	373	646	70	858	13,5

Order code
Ordre kode
Beställningskod
Tuotekoodi
Bestellcode
Codice d'ordine
Codification

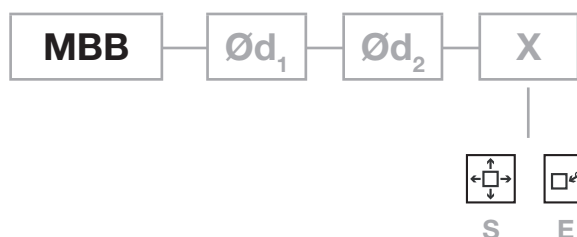



Integra

MBB

Accessories-MBB

Tilbehør-MBB

Tillbehör-MBB

Lisävarusteet-MBB

Zubehör-MBB

Accessori-MBB

Accessoires MBB

- Mounting of MBB - MHS
- Ophængning af MBB - MHS
- Upphängning av MBB - MHS
- Kannakointi MBB - MHS
- Montage des MBB - MHS
- Montaggio di MBB - MHS
- Montage de MBB - MHS

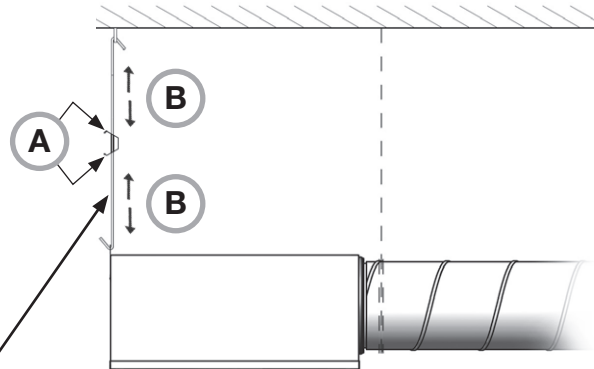
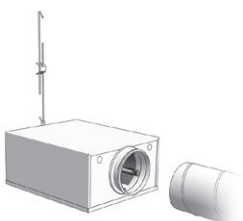

MHS

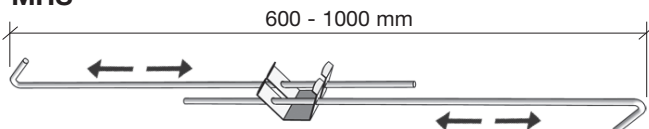

- Threaded bar
- Gevindstang
- Gängstång
- Kierretanko
- Gewindestange
- Barre filettate
- Tiges filetées

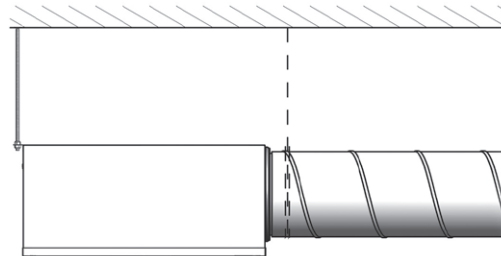
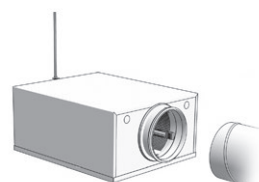

M6



- Directly against ceiling
- Direkte mod loft
- Dikt mot tak
- Suoraan kattopintaan
- Direkt an die Decke
- Direttamente a soffitto
- Directement contre le plafond

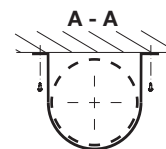
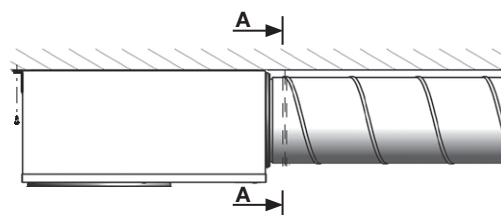
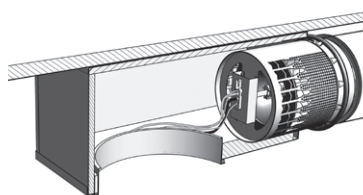

- Mounting of MBB, details go to - Mounting -and balancing instruction
- Ophængning af MBB, detaljer se - Montage -og indregulerings vejledning
- Upphängning av MBB, details go to - Montage och injusteringsinstruktion
- Kannakointi MBB, lisätietoja - Asennus- ja säätöohjeet
- Montage des MBB, details go to - Montage und Einregulierungsanweisung
- Montaggio di MBB, per dettagli vedere - Istruzioni di montaggio e bilanciamento
- Montage de MBB, détails voir - Instructions de montage et réglage





Integra Ø125-250

MBB

Accessories-MBB

Tilbehør-MBB

Tillbehör-MBB

Lisävarusteet-MBB

Zubehör-MBB

Accessori-MBB

Accessoires MBB

Mounting of diffuser Ø125-250 in MBB
Montering af armatur Ø125-250 i MBB
Montering av don Ø125-250 i MBB
Hajottajan Ø 125-250 asennus liitântälaatikkoon MBB
Durchlassmontage Ø125-250 im MBB
Assemblaggio di diffusori 125-250 ed MBB
Montage du diffuseur Ø125-250 dans MBB

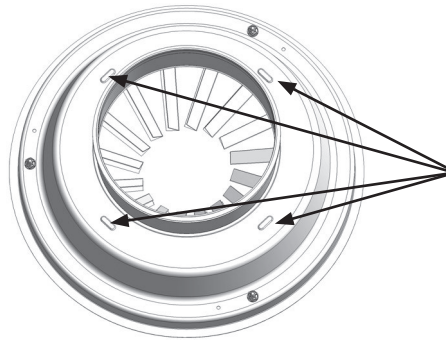
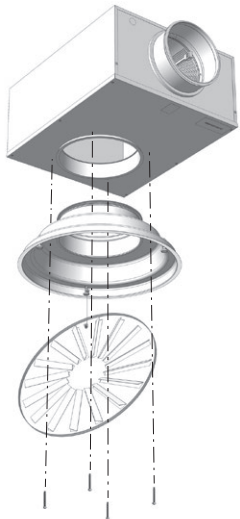

Holes for MBB mounting
 Huller til MBB montage
 Holes for MBB mounting - SWE
 Reiät MBB:n asennukseen
 Löcher für montage im MBB - GER
 Fori di montaggio per MBB
 Trous de montage pour MBB

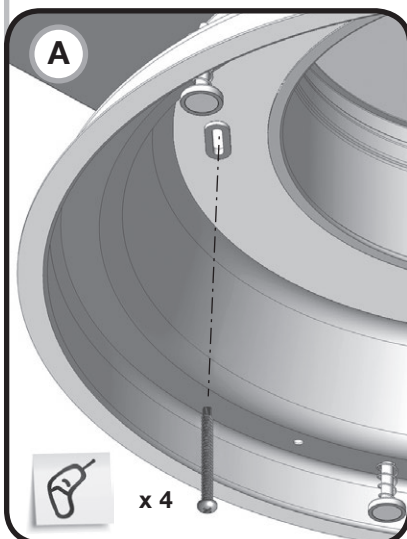
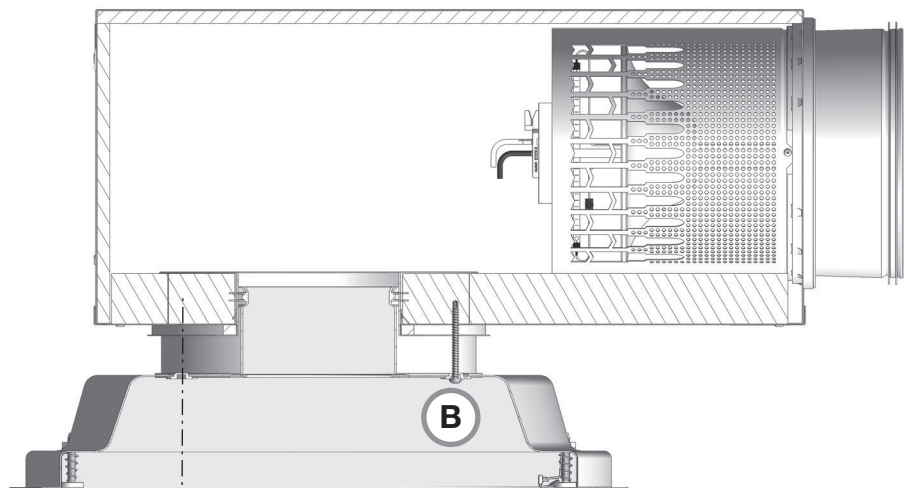

Included with MBB
 Medfølger med MBB
 Ingår med MBB
 Toimitetaan MBB:n mukana
 MBB wird inklusive eines Befestigungssatzes für den Durchlass geliefert!
 Incluso con MBB
 Accessoires inclus

4 x Ø4,8 x 50



Integra Ø315

MBB

Accessories-MBB

Tilbehør-MBB

Tillbehör-MBB

Lisävarusteet-MBB

Zubehör-MBB

Accessori-MBB

Accessoires MBB

- Mounting of diffuser Ø315 in MBB**
- Montering af armatur Ø315 i MBB**
- Montering av don Ø315 i MBB**
- Hajottajan Ø 315 asennus MBB-liitäntälaatikkoon**
- Durchlassmontage Ø315 im MBB**
- Assemblaggio di diffusori Ø315 ed MBB**
- Montage du diffuseur Ø315 dans MBB**

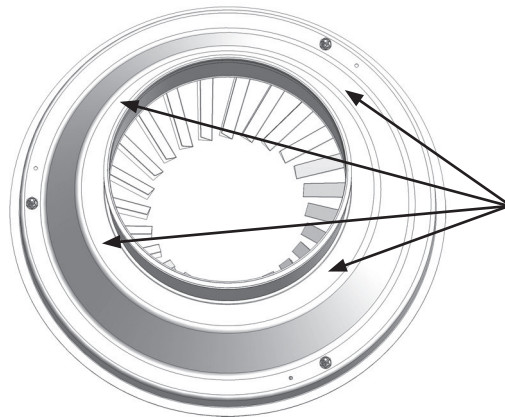

!

NO holes for MBB mounting !
 INGEN huller til MBB montage !
 NO Holes for MBB mounting !- SWE
 NO holes for MBB mounting ! - FIN
 KEINE Löcher für montage im MBB !
 NO fori di montaggio per MBB!
 Trous de montage pour MBB non disponibles

Self tapping screws - Not included
 Selvskærende skrue - ikke inkluderet
 Self tapping screws - Not included - SWE
 Itsekierteittävät ruuvit - Ei sisälly
 Self tapping screws - Not included - GER
 Viti autoforanti - Non include
 Vis autoforeuses - Non fournies

x 3

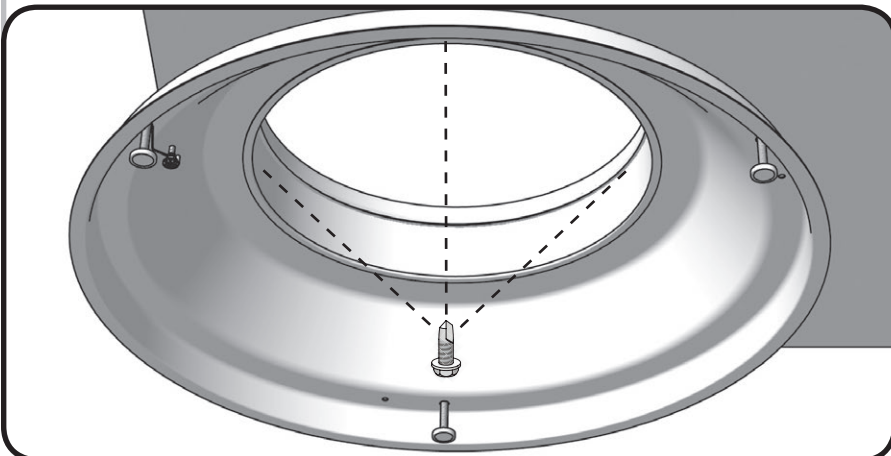
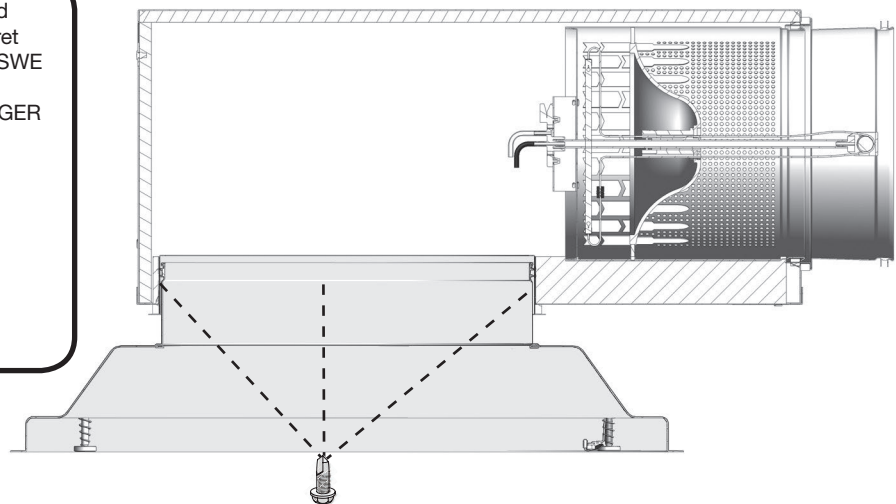

Not used
 Anvendes ikke
 Används inte
 Ei käytetä
 Nicht verwendet
 Non utilizzati - ITA
 Non utilisés

4 x Ø4,8 x 50



Integra

DCZ

Accessories-DCZ

Tilbehør-DCZ

Tillbehör-DCZ

Lisävarusteet-DCZ

Zubehör-DCZ

Accessori-DCZ

Accessoires-DCZ

Mounting of diffuser using DCZ
Montering af armatur med DCZ
Mounting of diffuser using DCZ -SWE
Hajottajan asennus käyttämällä kannakkeita DCZ
Montage des Durchlasses mit DCZ
Montaggio del diffusore utilizzando DCZ
Installation du diffuseur avec DCZ

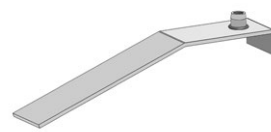

DCZ

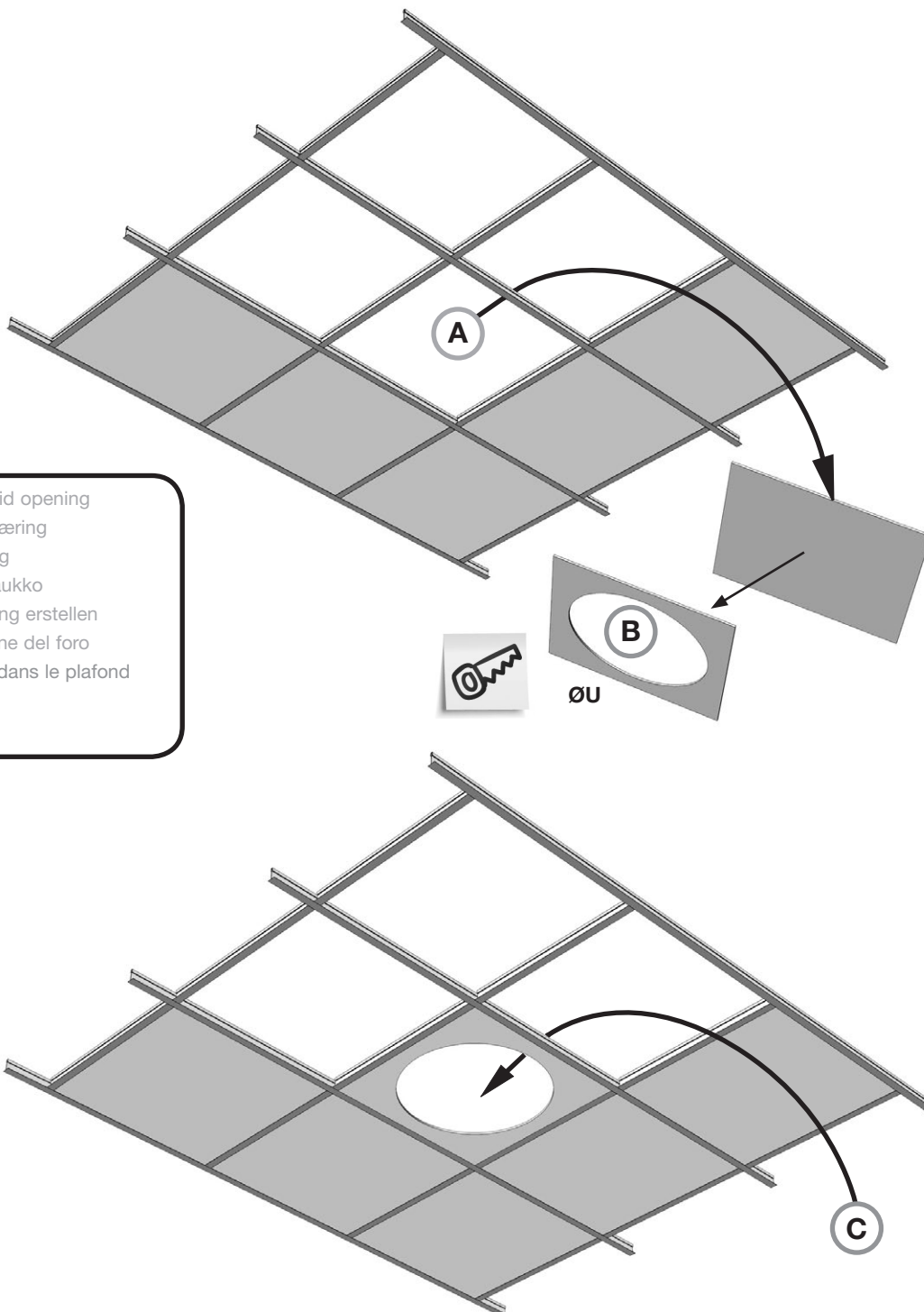

- ØU Ceiling grid opening
- ØU Loft udkæring
- ØU Håltagning
- ØU Asennusaukko
- ØU Aussparung erstellen
- ØU Dimensione del foro
- ØU Overture dans le plafond



Integra

DCZ

Accessories-DCZ

Tilbehør-DCZ

Tillbehör-DCZ

Lisävarusteet-DCZ

Zubehör-DCZ

Accessori-DCZ

Accessoires DCZ

Mounting of diffuser using DCZ
Montering af armatur med DCZ
Mounting of diffuser using DCZ -SWE
Hajottajan asennus käyttämällä kannakkeita DCZ
Montage des Durchlasses mit DCZ
Montaggio del diffusore utilizzando DCZ
Installation du diffuseur avec DCZ

DCZ

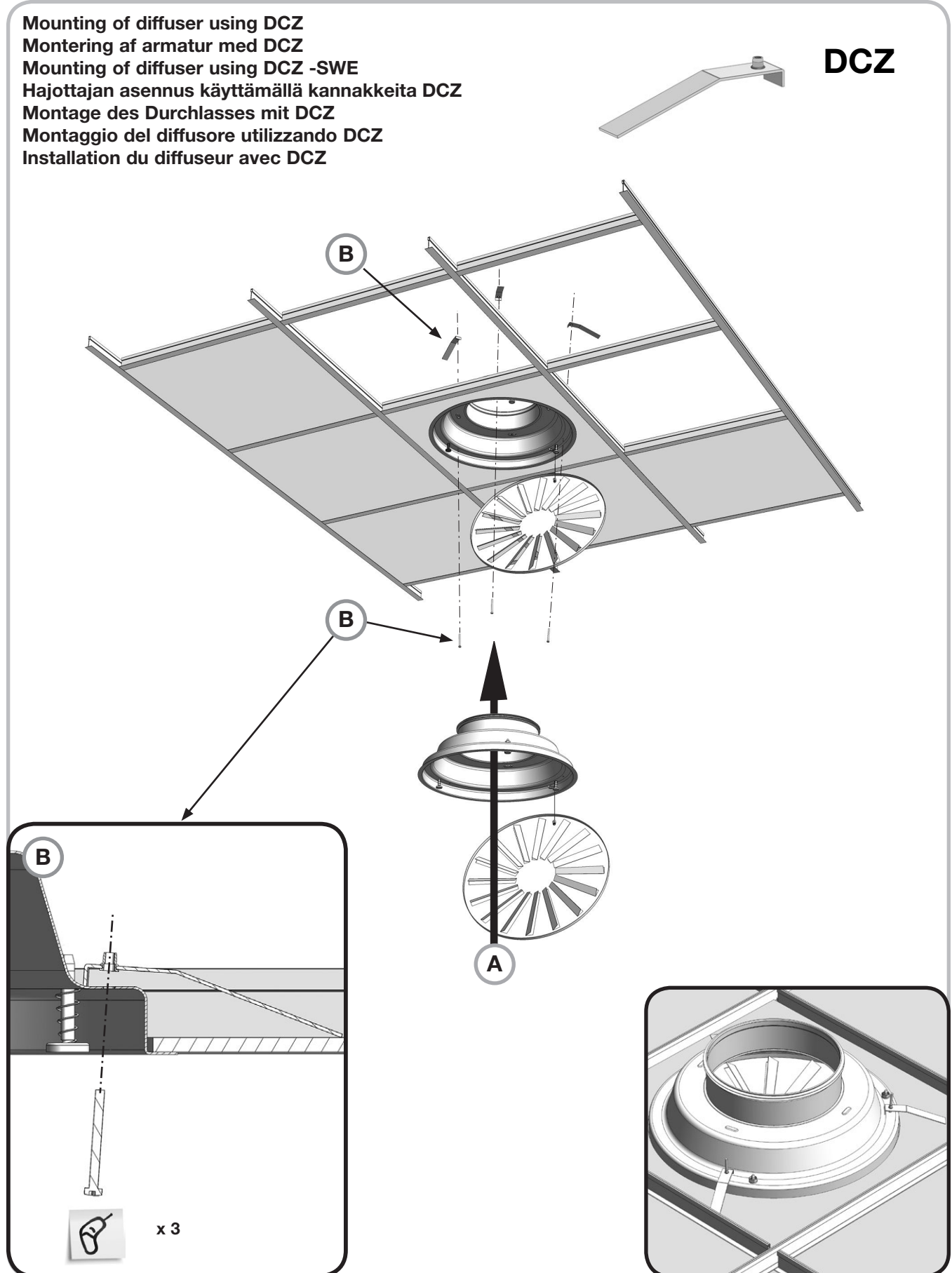



Integra

LM

Accessories-LM

Tilbehør-LM

Tillbehör-LM

Lisävarusteet-LM

Zubehör-LM

Accessori-LM

Accessoires-LM

Mounting of diffuser on the LM module plate
Montering af armatur på LM modulplade
Montering av don på LM modulram
Hajottajan asennus LM-moduulilevyyn
Montage des Durchlasses an der Modulplatte LM
Montaggio del diffusore su cornice LM
Montage du diffuseur sur la plaque d'habillage LM

LM

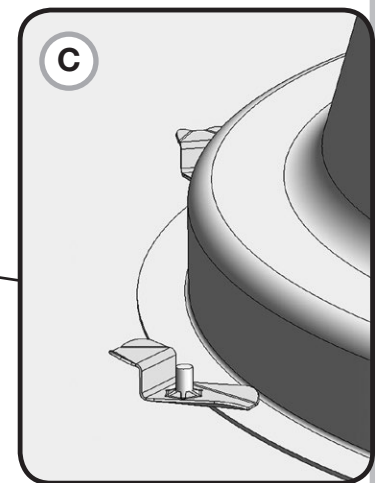
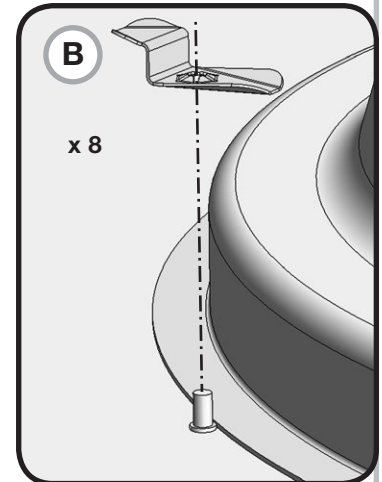
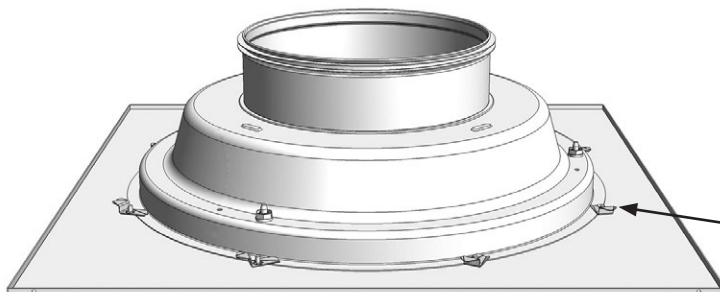
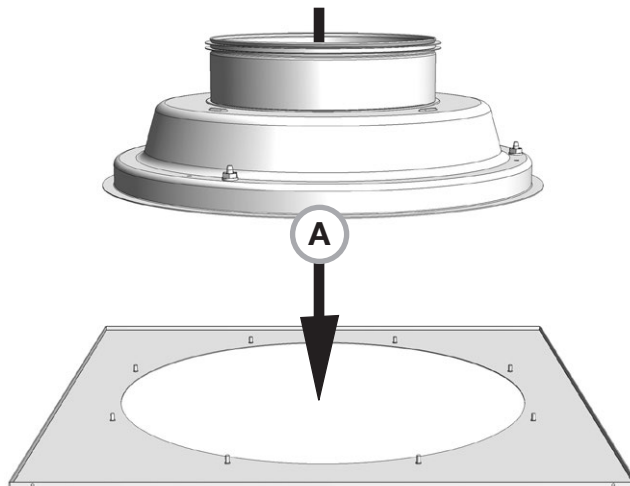
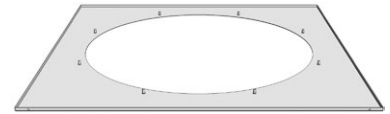

UK - LM module plate adapted to ceiling system 1 - 21
DK - LM modulplade tilpasset loftsystem 1 - 21
SE - LM module plate adapted to ceiling system 1 - 21
FI - LM-moduulilevy sovitettuna kattojärjestelmään 1-21
DE - Modulplatte LM angepasst für Deckensysteme 1-21
IT - Cornice LM adatta a controsoffitti 1 - 21
FR - Plaque d'habillage LM adaptée au système de plafond 1 - 21

Order code
Ordre kode
Beställningskod
Tuotekoodi
Bestellcode
Codice d'ordine
Codification



1-21

Ceiling system - Loftsystem Undertakssystem
 Kattojärjestelmät - Deckensysteme
 Sistemi di controsoffitto - Type de plafond

PC6 - PC7
 RC14 - RC15
 NC19 - RCG

Ød



Integra

LM

Accessories-LM

Tilbehør-LM

Tillbehör-LM

Lisävarusteet-LM

Zubehör-LM

Accessori-LM

Accessoires-LM

Mounting of diffuser in ceiling using moduleplate LM
Montering af armatur i loft med modulplade LM
Montering av don på LM modulram
Hajottajan asennus alakattoon LM-moduulilevyn avulla.
Montage des Durchlasses in der decke mit Modulplatte LM
Montaggio del diffusore in controsoffitto usando la cornice LM
Montage du diffuseur sur la plaque d'habillage LM

LM

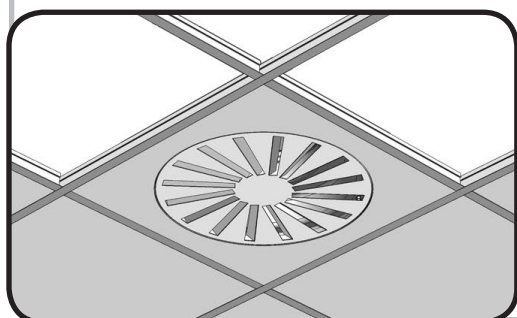
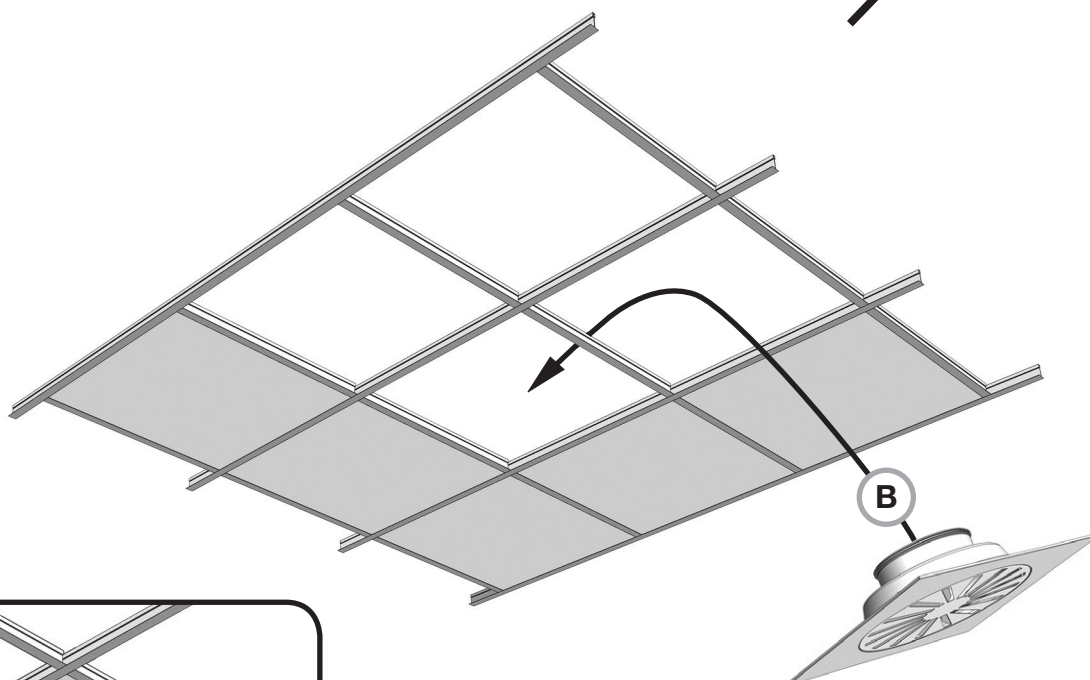
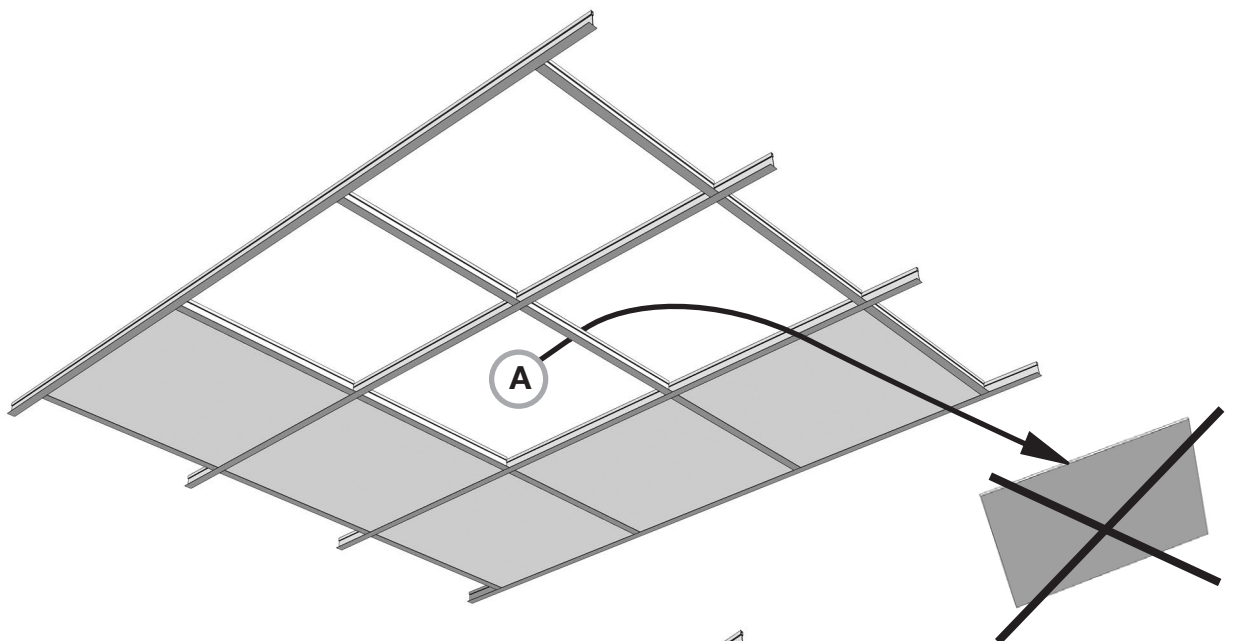
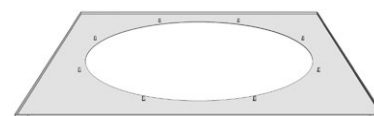



Integra Ø 125-250

LM

Accessories-LM

Tilbehør-LM

Tillbehör-LM

Lisävarusteet-LM

Zubehör-LM

Accessori-LM

Accessoires-LM

Mounting of diffuser + MBB in ceiling using moduleplate LM
Montering af armatur + MBB i loft med modulplade LM
Mounting of diffuser + MBB in ceiling using moduleplate LM -SWE
Hajottajan + MBB:n asennus alakattoon LM-moduulilevyn avulla
Montage des Durchlasses + MBB in der decke mit Modulplatte LM
Montaggio del diffusore con cornice LM + MBB
Montage du diffuseur + MBB dans le plafond avec plaque d'habillage LM

LM

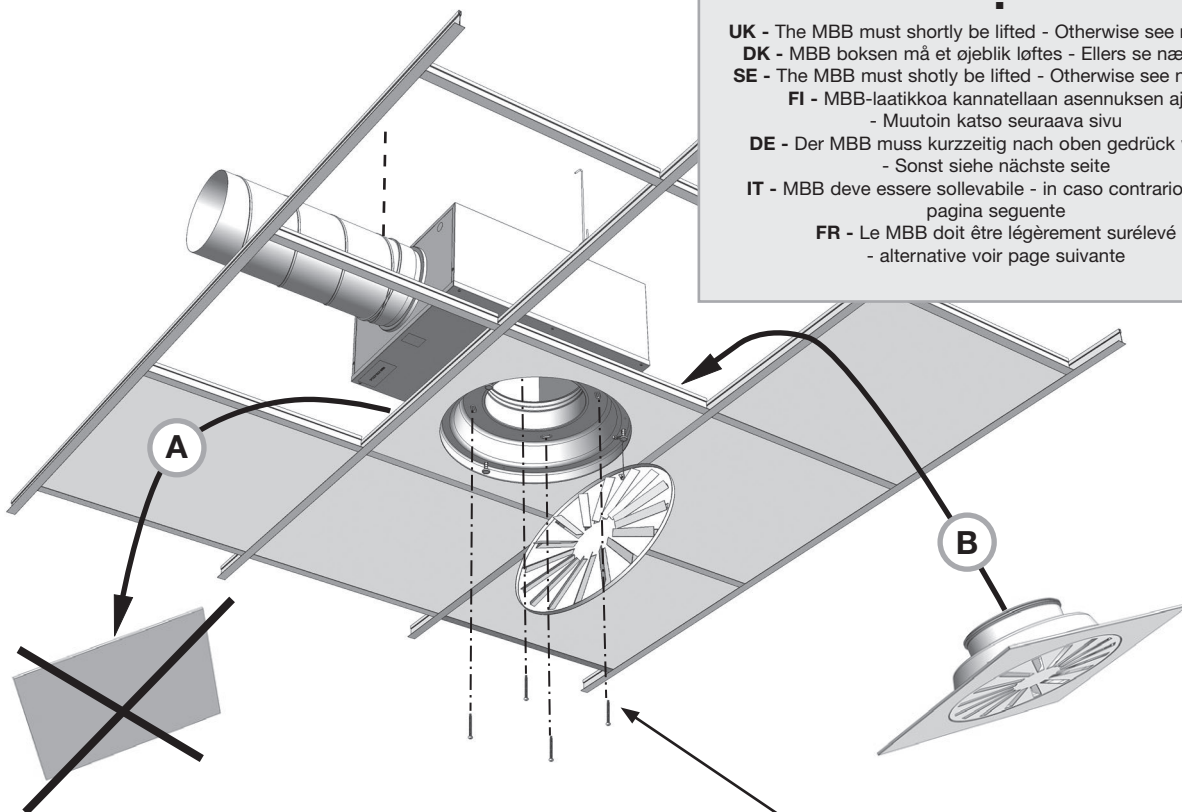
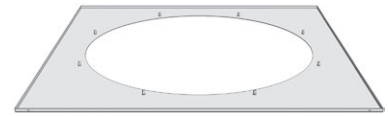

!
UK - The MBB must shortly be lifted - Otherwise see next page
DK - MBB boksen må et øjeblik løftes - Ellers se næste side
SE - The MBB must shortly be lifted - Otherwise see next page
FI - MBB-laatikkoa kannatellaan asennuksen ajan
 - Muutoin katso seuraava sivu
DE - Der MBB muss kurzzeitig nach oben gedrückt werden
 - Sonst siehe nächste seite
IT - MBB deve essere sollevabile - in caso contrario vedere pagina seguente
FR - Le MBB doit être légèrement surélevé
 - alternative voir page suivante

Included with MBB for diffuser Ø125-250
 Levereras med MBB för don Ø125 -250
 Medföljer MBB för diffusor Ø125-250
 Toimitetaan MBB:n mukana hajottajia Ø 125-250 varten
 MBB wird inklusive eines Befestigungssatzes für den Durchlass geliefert!
 Incluso con MBB per diffusori 125-250
 Accessoires inclus avec MBB pour montage du diffuseur Ø125-250

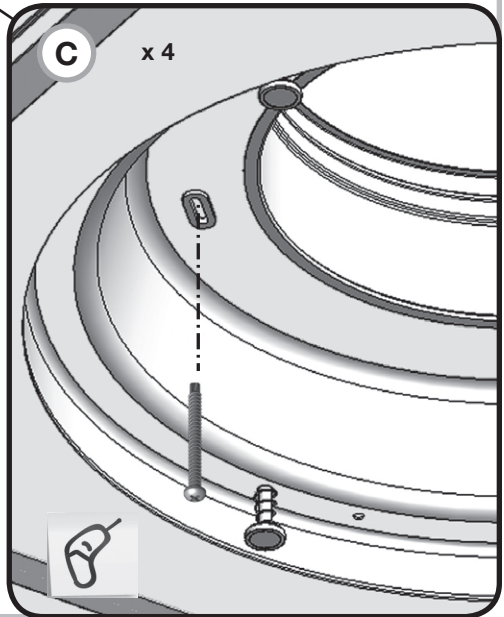

!
 Diffuser Ø315 - go to page 15
 Armatur Ø315 - se side 15
 Don Ø315 - Se sida 15
 Hajottaja Ø315 - Mene sivulle 15
 Durchlass Ø315 - siehe seite 15
 Diffusore Ø315 - vai a pagina 15
 Diffuseur Ø315 - voir page 15



Integra

LM

Accessories-LM

Tilbehør-LM

Tillbehör-LM

Lisävarusteet-LM

Zubehör-LM

Accessori-LM

Mounting of diffuser + MBB in ceiling using moduleplate LM

Montering af armatur + MBB i loft med modulplade LM

Mounting of diffuser + MBB in ceiling using moduleplate LM -SWE

Hajottajan + MBB:n asennus alakattoon LM-moduulilevyn avulla

Montage des Durchlasses + MBB in der decke mit Modulplatte LM

Montaggio del diffusore con cornice LM + MBB

Montage du diffuseur + MBB dans le plafond avec plaque d'habillage LM

LM

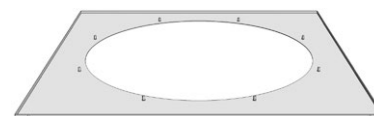

!

Not enough space above suspended ceiling when mounting MBB + LM - Remove one T-runner while mounting

For lidt plads over nedsænket loft ved montage af MBB + LM - Fjern en loft-skinne under montage

Not enough space above suspended ceiling when mounting MBB + LM - Remove one T-runner while mounting -SWE

Jos alakatton yläpuolella ei ole tarpeeksi tilaa asennuksen aikana, poista yksi T-lista asennuksen ajaksi

Wenig Platz im Deckenhohlraum bei Montage MBB + LM - Entfernen Sie einen T-Träger für die Montage

In caso non vi sia spazio in fase di montaggio dell'MBB + LM - Smontare una barra a T

Pas assez de place dans le plafond lors du montage de MBB + LM - Retirer un support en T pendant le montage

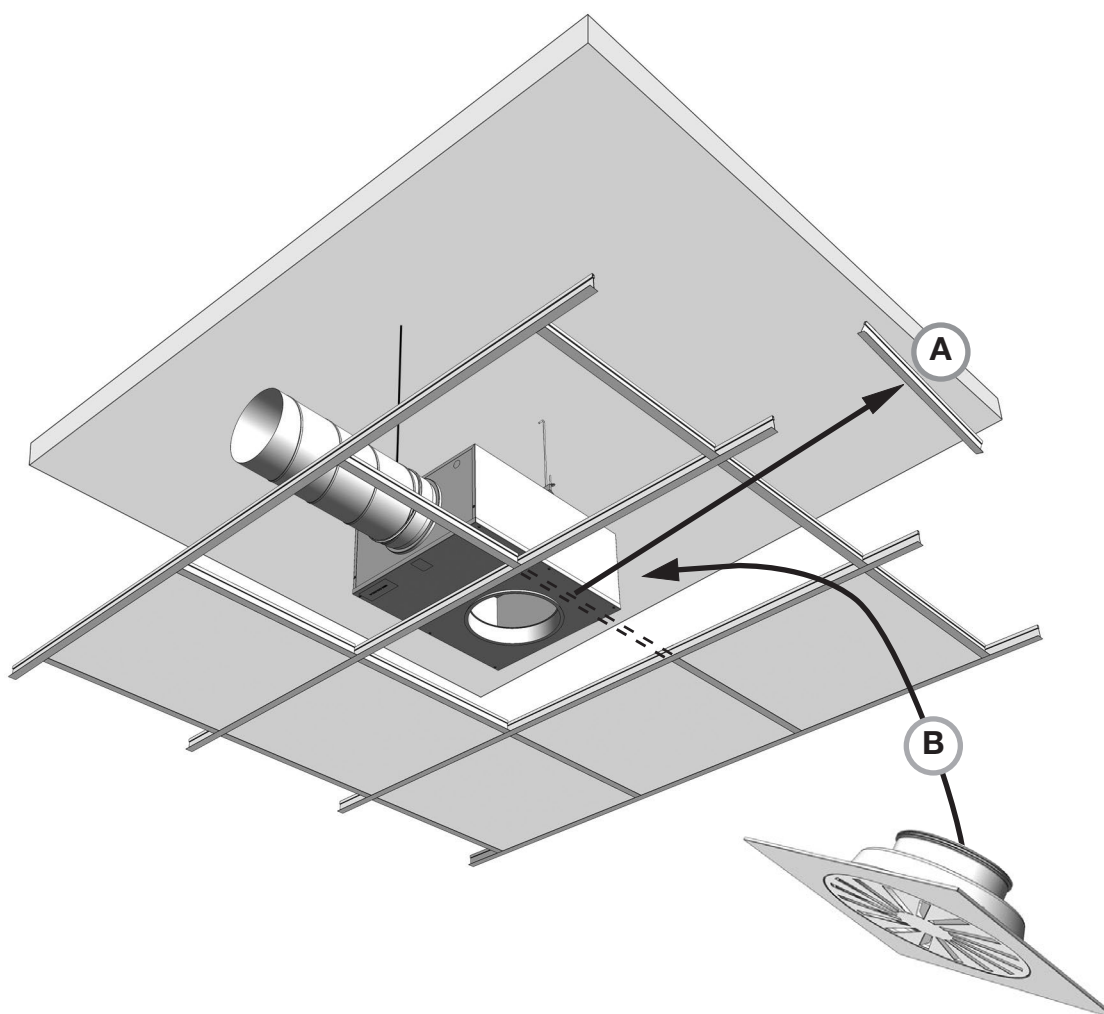



Integra

LM

Overview-LM

Oversigt-LM

Översikt-LM

Yleiskatsaus-LM

Übersicht-LM

Panoramica-LM

Aperçu-LM

Overview LM module plates
Oversigt LM modulplader
Översikt LM Modulramar
Yleiskatsaus LM Moduulilevy
Übersicht LM Modulplatten
Panoramica LM Piastra modulare per controsoffiti
Aperçu plaques d'habillage LM

! **LM**

UK - LM module plate adapted to ceiling system 1 - 21
 DK - LM modulplader tilpasset loftsystem 1 - 21
 SE - LM modulramar anpassat till undertakssystem 1 - 21
 FI - LM-moduulilevy sovitettu kattojärjestelmään 1-21
 DE - LM Modulplatten angepasst für Deckensysteme 1-21
 IT - La cornice LM è adatta per sistemi di controsoffitto tipo 1 - 21
 Plaques d'habillage LM adaptées aux systèmes de plafond 1 - 21

1, 21

1. = 600 x 600
 21.= 625 x 625

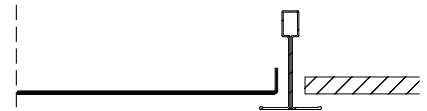
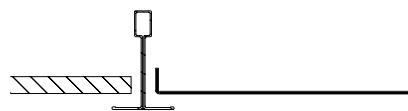

4, 5, 6

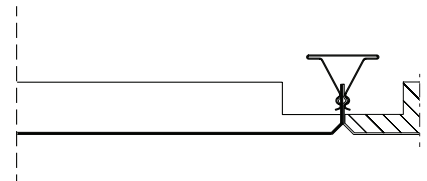
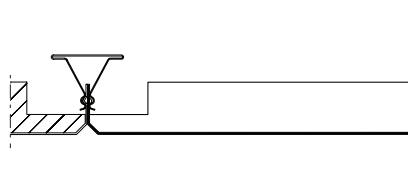

7, 8

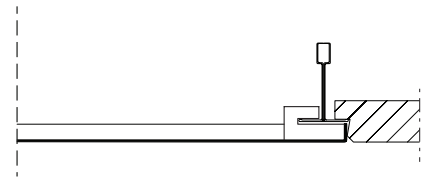
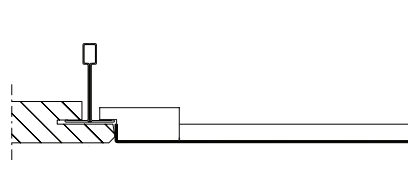

9, 10

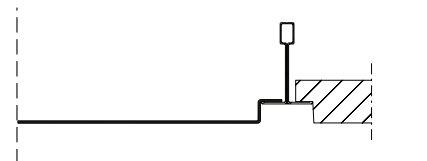
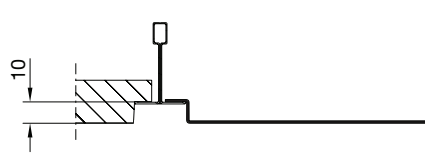

11

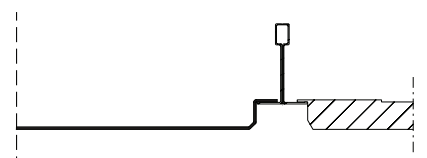
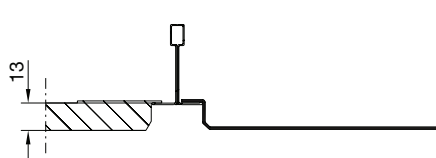

14

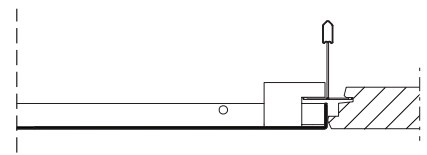
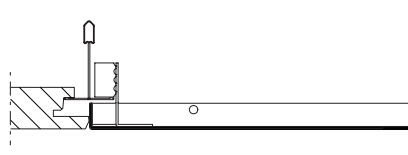



Integra

Overview

Oversigt

Översikt

Yleiskatsaus

Übersicht

Panoramica

Aperçu

Overview - Ceiling systems

Oversigt - loftsystemer

Översikt - Undertakssystem

Yleiskatsaus - Kattojärjestelmät

Übersicht - Deckensysteme

Panoramica - Sistemi di controsoffitto

Aperçu - Systèmes de plafond

1.
21.

T24/T15 = 600 x 600
22 = 625 x 625

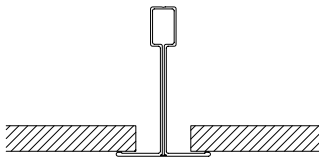

3.

Permanent ceiling
Fast loft / Fast undertak
Kiinteä alakatto
Geschlossene Decke
Soffitto permanente
Plafond non démontable

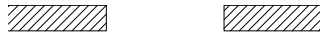

4.

Dampa Clip-in

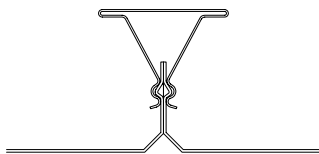

5.

Dampa Clip-in

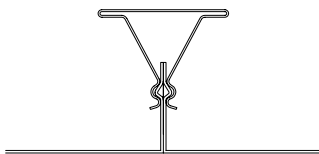

6.

Luxalon Clip-in

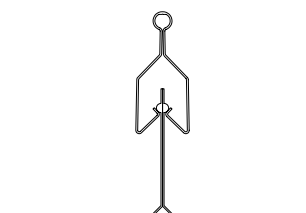

7.

Danotile Contur / Ecophon D
Rockfon D-XL

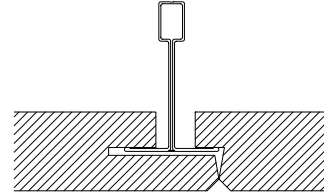

8.

Ecophon Focus DG

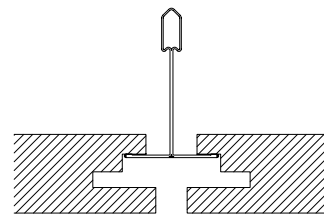

9.

Rockfon E10 24 / Ecophon E / T24

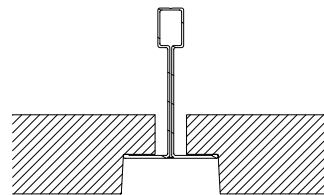

10.

Rockfon E10 15 / Ecophon E / T15

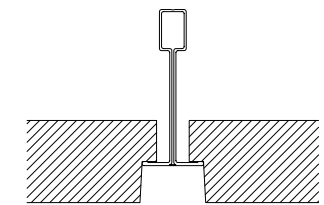

11.

Danotile Markant

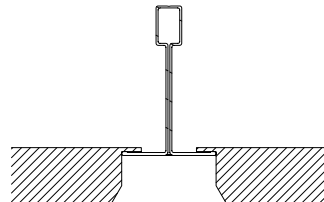

14.

Ecophon Focus DS

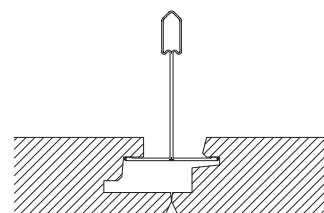

Support
Hjælp
Hjälp
Tuotetuki
Unterstützung
Supporto
Помощь
Support

UK - Here you can find product updates/mounting instructions and support telephone number/mail.

www.lindab.com

Right to alterations reserved.

DK - Her kan du finde seneste produkt opdateringer/ montagevejledninger samt support tlf. nr/mail.

www.lindab.dk

Ret til ændringer forbeholdes.

SE - Här kan du alltid hitta senaste produktuppdateringarna/montageanvisningarna samt support tel. /e-mail.

www.lindab.se

Rätt till ändringar förbehålles.

FI - Täältä löydät uusimmat tuotetiedot ja asennusohjeet sekä tuotetuen yhteystiedot.

www.lindab.fi

Oikeus muutoksiin pidätetään.

DE - Hier finden Sie aktuelle Produktinformationen/ Montageanleitungen und Telefonnummer/ E-Mail-Adressen der Ansprechpartner.

www.lindab.de

Änderungen vorbehalten.

IT - Qui potete trovare istruzioni di montaggio, informazioni sul prodotto ed un supporto tecnico qualificato
Tel. 011 9952099 - e-mail: lindab@lindab.it

www.lindab.it

Soggetto a modifica senza obbligo di preavviso.

RU - Здесь вы можете найти обновления изделия/ инструкции по монтажу и техн. поддержку по тел. / электронной почте.

www.lindab.ru

Сохраняется право на внесение изменений

FR - Vous trouverez les fiches produits ou de montage actualisées ainsi que les coordonnées du support téléphonique à l'adresse suivante :

www.lindab.fr

Toutes modifications réservées.

**Do you have trouble finding your local contacts
please go to:**

www.lindabcomfort.com

INTEGRA-27112013



www.lindab.com