



# Regula combi

## Mounting



1. Demount the face plate.



2. Remove the front including the circuit board



3. Mount the bottom plate on electrical box or directly on the wall



4. Remount in inverse arrangement when the plinths are connected. Notice that the front and bottom plate only can be fitted to each other in one way. See mark "UP".

## Electrical wiring diagrams

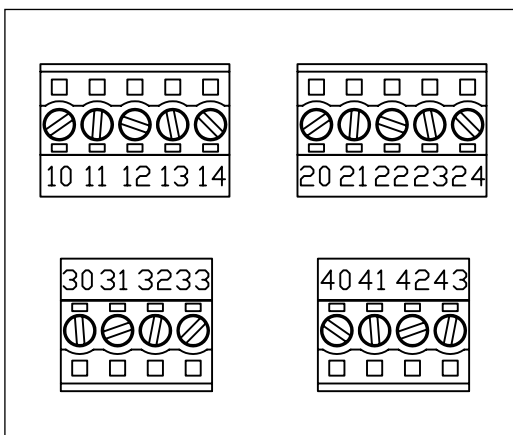



# Regula combi

## Electrical wiring diagrams

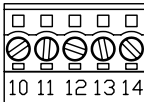
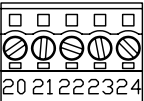
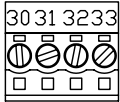
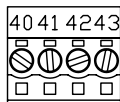
	<p><b>10</b> G Supply voltage 24 V AC</p> <p><b>11</b> G0 Supply voltage 0 V</p> <p><b>12-14</b> No function.</p>
	<p><b>20</b> GDO 24 V AC out common for DO. Internally connected to terminal 10, G.</p> <p><b>21</b> G0 0 V common for UO. Internally connected to terminal 11, G0.</p> <p><b>22</b> UO3 Control output forcing (cooling). For a 0...10 V DC actuator, max 5 mA. The actuator's 0...10 V control signal terminal is connected to terminal 22 and its supply terminals to terminals 20 and 21. Make sure that the reference pole G0 is connected to the correct terminal on the actuator. Alternative For a 24 V AC thermal actuator, max 2.0 A. The thermal actuator is connected between terminals 22 and 20, GDO.</p> <p><b>23</b> UO1 Control output heating. For a 0...10 V DC actuator, max 5 mA. The actuator's 0...10 V control signal terminal is connected to terminal 23 and its supply terminals to terminals 20 and 21. Make sure that the reference pole G0 is connected to the correct terminal on the actuator. Alternative For a 24 V AC thermal actuator, max 2.0 A. The thermal actuator is connected between terminals 23 and 20, GDO.</p> <p><b>24</b> UO2 Control output cooling. For a 0...10 V DC actuator, max 5 mA. The actuator's 0...10 V control signal terminal is connected to terminal 24 and its supply terminals to terminals 20 and 21. Make sure that the reference pole G0 is connected to the correct terminal on the actuator. Alternative For a 24 V AC thermal actuator, max 2.0 A. The thermal actuator is connected between terminals 24 and 20, GDO.</p>
	<p><b>30</b> AI1 For temperature sensor, PT1000. Measuring range 0...50°C. The sensor is connected between terminals 30 and 41, AGnd.</p> <p><b>31</b> AI2 For a 0...10 V CO2 sensor</p> <p><b>32</b> DI1 Presence sensor. A potential-free contact is connected between terminals 32 and 40, +C. Open contact corresponds to occupancy.</p> <p><b>33</b> DI2/CI Condensation detector. The sensor is connected between terminals 33 and 41, AGnd.</p>
	<p><b>40</b> +C 24 V DC out common for DI</p> <p><b>41</b> AGnd Analogue ground, reference for AI</p> <p><b>42</b> A RS485-communication A</p> <p><b>43</b> B RS485-communication B</p>

## Set program on Regula Combi

To enter the parameter menu and change program the following steps should be followed:

1. Simultaneously hold the INCREASE and DECREASE buttons depressed for about 5 seconds
2. Then press the INCREASE button twice.
3. The Service indication will be displayed.
4. The display will now show the parameter number 0 (which chooses program).
5. Press the Occupancy button to select the desired parameter.
6. The parameter number will be replaced by the parameter value.
7. The value can be changed using the INCREASE and DECREASE buttons.
8. To retrieve the original value, i.e. the value before change, press the INCREAS and DECREASE buttons at the same time. The original value is shown on the display.
9. To acknowledge and store a set parameter value, press the Occupancy button again, the display then returns to showing the parameter number.

After a certain time, about 1 minute, or when the INCREASE and DECREASE buttons are pressed at the same time while in the menu, the display returns to the normal view. Exit is shown on the display after the last parameter. The parameter menu is exited by pressing the Occupancy button while in Exit.



# Regula combi

## Parameter list

Parameter number	Description	Default
0	Regula Combi Programs: 0=Regin Regio Midi RC-CDOC, 1=Water, 2=VAV, 3=eHybrid, 4=Change Over digital, 5=Change Over sensor, 6=Pascal VAV supply, 7=Pascal VAV exhaust	1
1	Basic heating setpoint	21°C
2	Basic cooling setpoint	22°C
3	Neutral zone at Stand-by, Heating sp=Basic sp heating-2, Cooling sp=Basic sp cooling+2	2°C
7	P-band for room controller	10°C
8	I-time (s) for room controller	300 s
9	With a lower temperature on the analogue change-over input, the cooling function is selected	-3
10	With a higher temperature on the analogue change-over input, the heating function is selected	+4
12	Time in Bypass mode	45 min
13	Disconnect timer with occupancy/unoccupancy	30 min (eHybrid 20 min)
15	State connected sensor on AI1: 0=internal sensor, 1=External room sensor	0
20	State function of signal on UO1: 0=None, 1=Thermal actuator heat, 2=None, 3=Heating actuator 0...10V, 4=None	1
21	State function of signal on UO2: 0=None, 1=None, 2=Thermal actuator cooling, 3=None, 4=Cooling actuator 0...10V	2
22	State function of signal on UO3: 0=None, 1=Forced vent. digital, 2=None, 3=None, 4=Cooling actuator 0...10V	4
36	Time in hours between exercise of heating actuator	23 (COS:3)
42	Select if setpoint or actual value is to be shown in display, 0=Actual, 1=Heating setpoint, 2=Cooling setpoint, 3=Average value of heating and cooling setpoint, 4=Only setpoint displacement, 5=CO2 concentration in the room in ppm	0
43	Highest permitted setpoint offset upwards	3°C
44	Highest permitted setpoint offset downwards	3°C
45	Preset operating mode: 1=Unoccupied, 2=Stand-by, 3=Occupied. Forced ventilation is not set in Occupied mode	2
48	Min flow at cooling output when control state Heat/cool with VAV-control is selected	20
49	Max flow at cooling output when control state Heat/cool with VAV-control is selected and heating is applied	0
56	Temperature compensation on AI1	0°C
58	Temperature compensation of internal room sensor	0°C
60	State NO/NC digital input 1 0=NO (Normally open), 1=NC (Normally closed)	1 (eHybrid 0)
61	State NO/NC digital input 2 0=NO (Normally open), 1=NC (Normally closed)	1
62	State NO/NC universal input 1 0=NO (Normally open), 1=NC (Normally closed)	0
73	Selection of heating output function (NO/NC): 0=NC, 1=NO	0
74	Setpoint display at setpoint adjustment:0=The offset is shown in the display, 1=The active setpoint + offset are shown in the display. HEAT or COOL is shown depending on whether the unit controls according to the heating or cooling setpoint when you enter the menu, 2=The heating setpoint + offset are shown in the display, 3=The cooling setpoint + offset are shown in the display.	1
77	Operating mode at occupancy indication (DI1): 3=Occupied, 4=Bypass	3
80	Selection of cooling output function UO2 (NO/NC): 0=NC, 1=NO	0
112	Min. limit for the VAV damper when using CO2 control	800
113	Max. limit for the VAV damper when using CO2 control	1000

Default values program 1 water.



# Regula combi

## Program descriptions

### 1. Water

The regulation of temperature takes place in sequences with heating, cooling and forced (cooling) ventilation by signals from the universal outputs UO1 (heating), UO2 (cooling) and UO3 (forced cooling ventilation). The temperature is controlled according to diagram 1. Set points are adjustable.

Operating mode Standby occurs after 30 min (adjustable) if a presence sensor is connected and signal is given, then the neutral zone increases with +/- 2°C (to heating set point 19°C and cooling set point 24°C).

If a CO2 sensor is connected the universal output signal UO3 will be affected according to the CO2 sequence. The major requirement from the second part of the cooling sequence and the CO2 sequence will control the UO3 signal.

If UO3 ascends to 100% signal, Bypass operating mode will be activated for 45 min (adjustable). Bypass can also

be activated by pressing the Occupancy button once (for less than 5 seconds).

The universal outputs for UO1 and UO2 is default set to thermal on/off actuators. UO3 is default set to 0-10V.

Heating and cooling actuators (UO1 and UO2) are exercised every 23 h.

### 2. VAV

The regulation of temperature takes place in sequences with heating and cooling by signals from the universal outputs UO1 (heating) and UO2 (cooling). The universal output UO3 (forced cooling ventilation) will be activated with 100% signal by pressing the Occupancy button (Bypass operating mode).

As default the UO2 signal will also change to 100% when pressing the Occupancy button.

The temperature is controlled according to diagram 2. Set points are adjustable.

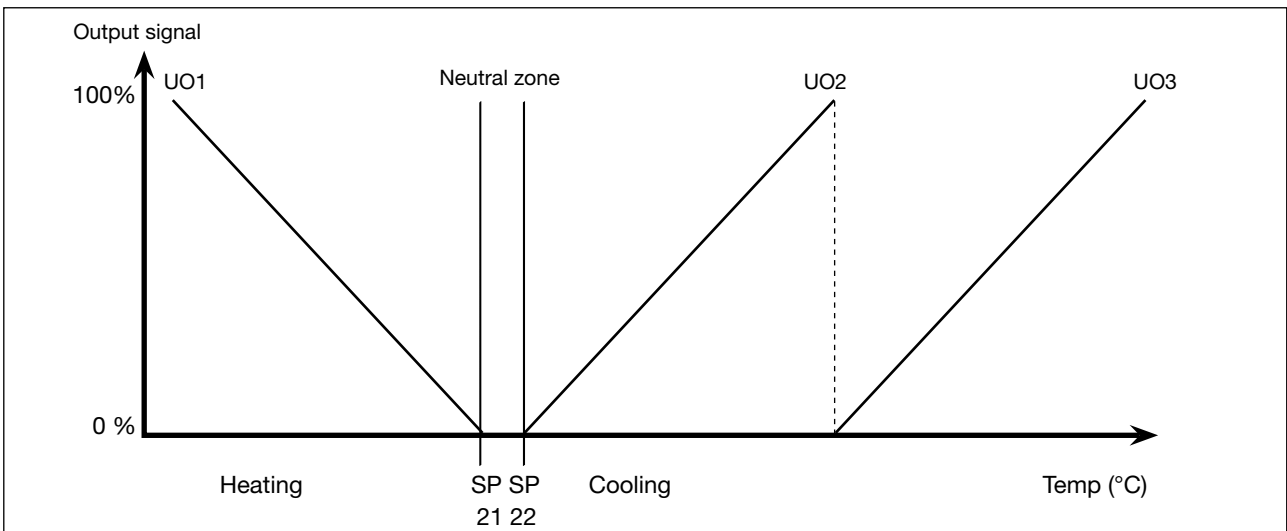

Diagram 1. Temperature sequences for program 1 water.

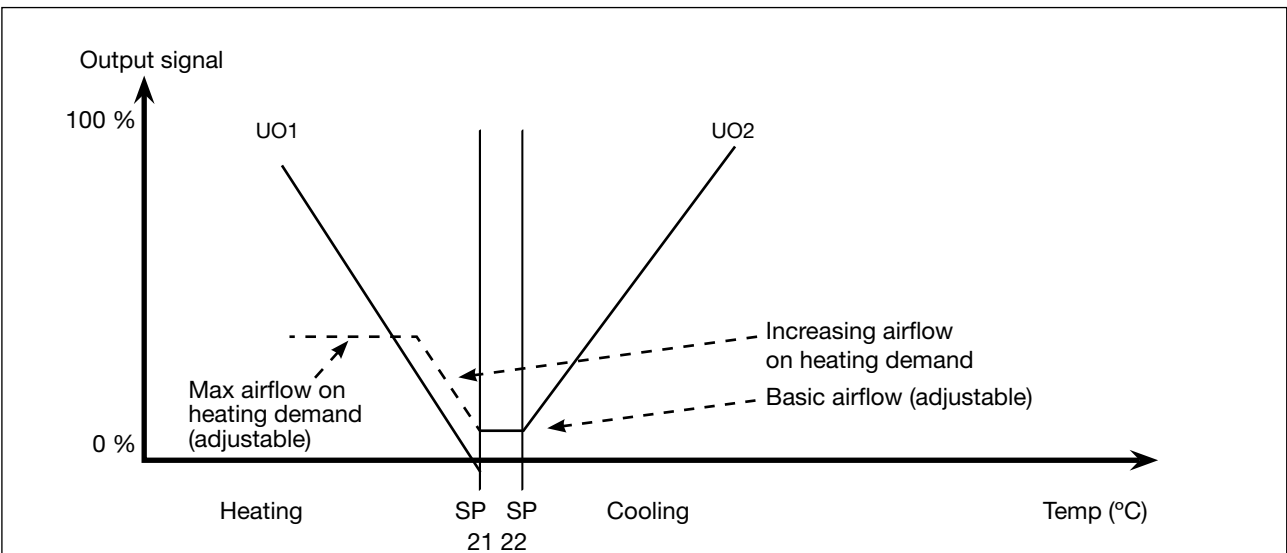

Diagram 2. Temperature sequences for program 2 VAV



# Regula combi

The basic airflow is set to 20% (default), so the cooling sequence will result in signals from 20-100%. By pressing the Occupancy button for more than 5 seconds operating mode Off will occur, that will change the UO2 signal to 0% regardless of cooling or heating demands. This match Lindab volume flow regulator functions.

A heating function for UO2 can be activated (by changing parameter 11 to value 5 instead of 4). This will allow UO2 to follow the heating signal UO1 to a free chosen max level (parameter 49) when there is heating demand. This should only be used when having heated air (above room temperature) in the duct e.g. by connecting UO1 to a duct heater. If the heating function on UO2 is activated forced cooling ventilation by pressing the Occupancy button will not lead to 100% signal on UO2.

Operating mode Standby occurs after 30 min (adjustable) if a presence sensor is connected and signal is given, then the neutral zone increases with +/- 2°C (to heating set point 19°C and cooling set point 24°C).

If a CO2 sensor is connected the universal output signal UO2 will be affected according to the CO2 sequence. The major requirement from the cooling sequence and the CO2 sequence will control the UO2 signal.

Bypass operating mode with UO2 and UO3 = 100% signal will be activated for 45 min (changeable) by pressing the occupancy button once (for less than 5 seconds).

The universal outputs for UO1, UO2 and UO3 are default set to 0-10V.

Heating and cooling actuators (UO1 and UO2) are exercised every 23 h.

### 3. eHybrid

The regulation of temperature takes place in sequences with heating and cooling by signals from the universal outputs UO1 (heating) and UO2 (cooling). The sequence of UO3 is depending on whether there is occupancy or not. At operating mode Occupied UO3 = 100%. At Standby UO3 is following the cooling signal UO2 and the heating signal UO1 to a changeable max limit (default is 0%, so as default the UO3 damper will stay closed at heating demands). See the sequences below. Set points are adjustable.

Operating mode Standby occurs after 30 min (adjustable) if a presence sensor is connected and signal is given, then the neutral zone increases with +/- 2°C (to heating set point 19°C and cooling set point 24°C).

The universal outputs for UO1 and UO2 is default set to thermal on/off actuators. UO3 is default set to 0-10V. Heating and cooling actuators (UO1 and UO2) are exercised every 23 h.

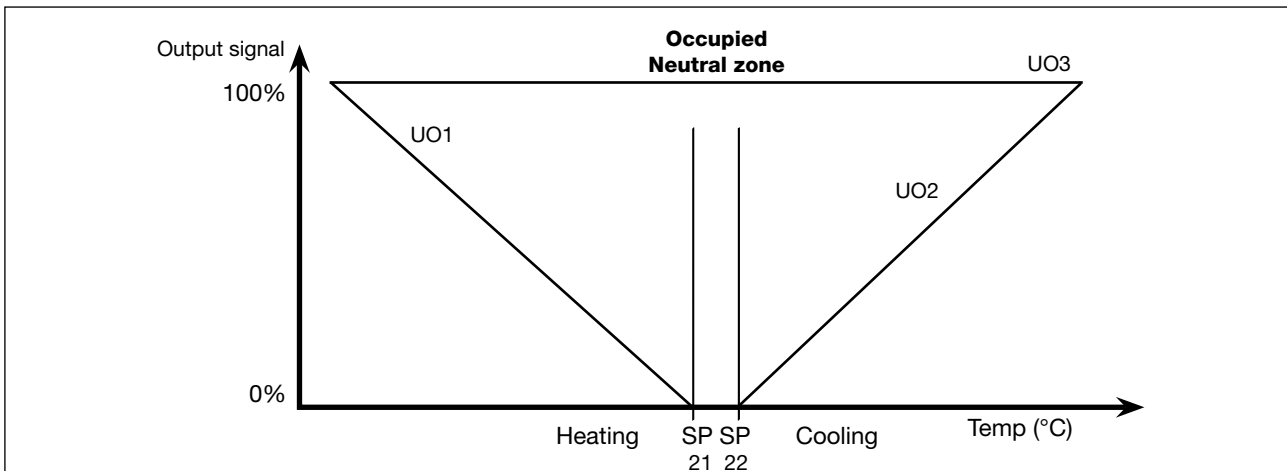

Diagram 3.

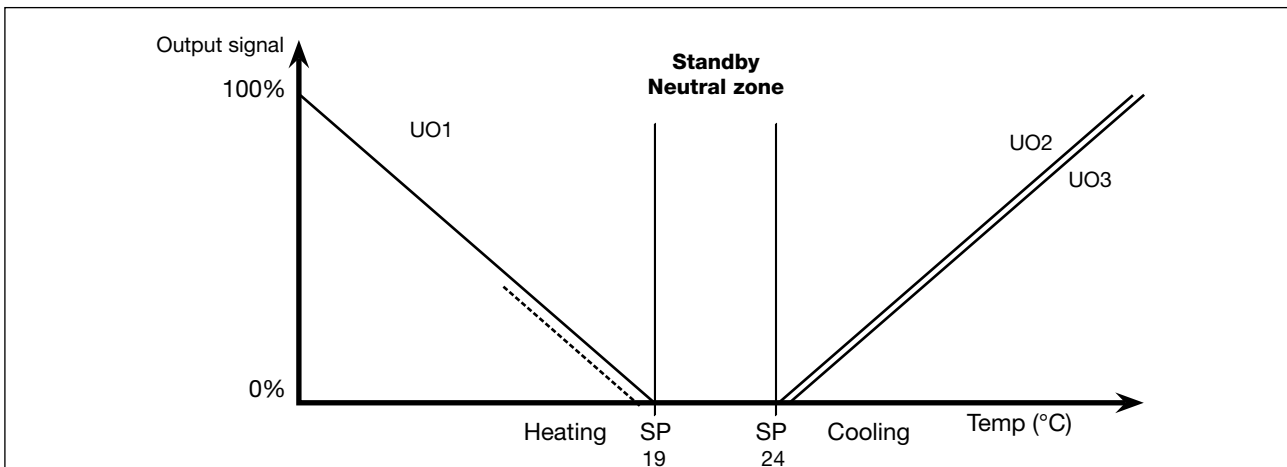

Diagram 4.



# Regula combi

## 4. Change Over digital

Change-over is a function, which makes it possible to use the same pipe/duct for both heating and cooling, depending on requirements during for example summer (cooling output) and winter (heating output).

When using the digital signal input DI2 (potential-free contact), closing the contact switches the change-over function and sets the output UO1 to cooling sequence.

On open contact, the change-over function sets the output UO1 to heating. Sequences for temperature, CO<sub>2</sub> and occupancy functions is as Program 1 Water. Universal outputs for UO1 and UO3 is default set to 0-10V. UO2 is not active.

## 5. Change Over sensor

Change-over is a function, which makes it possible to use the same pipe/duct for both heating and cooling, depending on requirements during for example summer (cooling output) and winter (heating output).

The Pt1000-sensor connected to AI1 must be mounted so that it senses the temperature in/on the heating/cooling media.

If the media temperature is higher than the room temperature the heating sequence is active on UO1. If the media temperature is lower than the room temperature the cooling sequence is active on UO1. When valves/dampers are closed, water/air will be stagnant at the media temperature sensor, so in this program there is exercise of the valves/ dampers for 10 min every 3 h (adjustable). In the exercise period the difference between room temperature and media temperature is checked. If the difference is larger than 3 K (changeable) for heating or 4 K (changeable) for cooling then there will be 0% output on UO1 until next exercise.

Sequences for temperature, CO<sub>2</sub> and occupancy functions are as Program 1 Water. Universal outputs for UO1 and UO3 is default set to 0-10V. UO2 is not active.

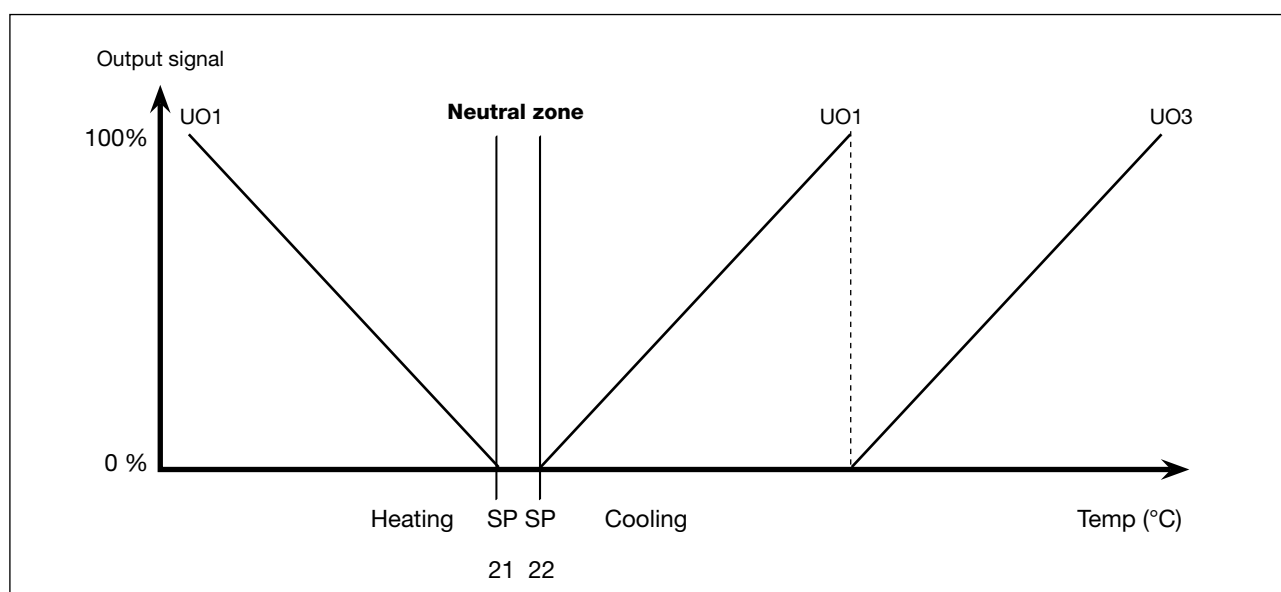

Diagram 5.



# Regula combi

## Circuit diagrams

The maximum number of actuators that can be connected to the digital output (ON/OFF) is 10 for cooling and heating, respectively. When more than 4 actuators for cooling or heating are connected, terminal blocks 10 and 20 must be connected with a cable.

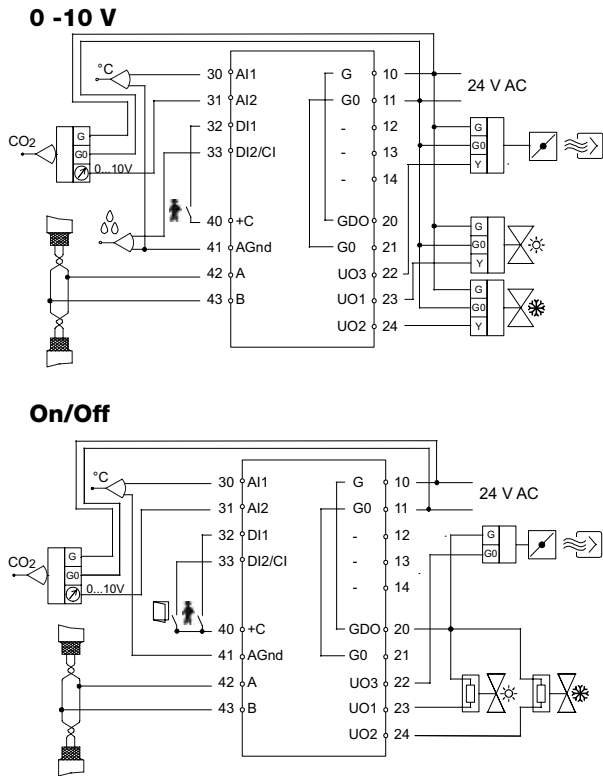

## Maintenance

Regula Combi is maintenance free. Use a damp cloth for cleaning the unit.

**NB!** Water should not come into the Regula Combi.

## Display handling and indications

Regula Combi has an Occupancy button, as well as an INCREASE button and a DECREASE button to increase and decrease the set point.

### Example:

The control setpoint is 22°C and the added displacement is +1.5°C. This means that the value 23.5°C will be shown in the display. "HEAT" or "COOL" will flash depending on which of the setpoint values is the control setpoint when you enter the set point menu, i.e. depending on which set point you are changing. The displacement is added to both the heating and cooling set point.

