



# Room Air Conditioner

(Convertible Type)

## **SERVICE MANUAL**

**MODEL: LV-B2461CL/ B2461HL  
LV-B2464CL/ B2464HL  
LV-B1861CL/ B1861HL  
LV-B1864CL/ B1864HL**

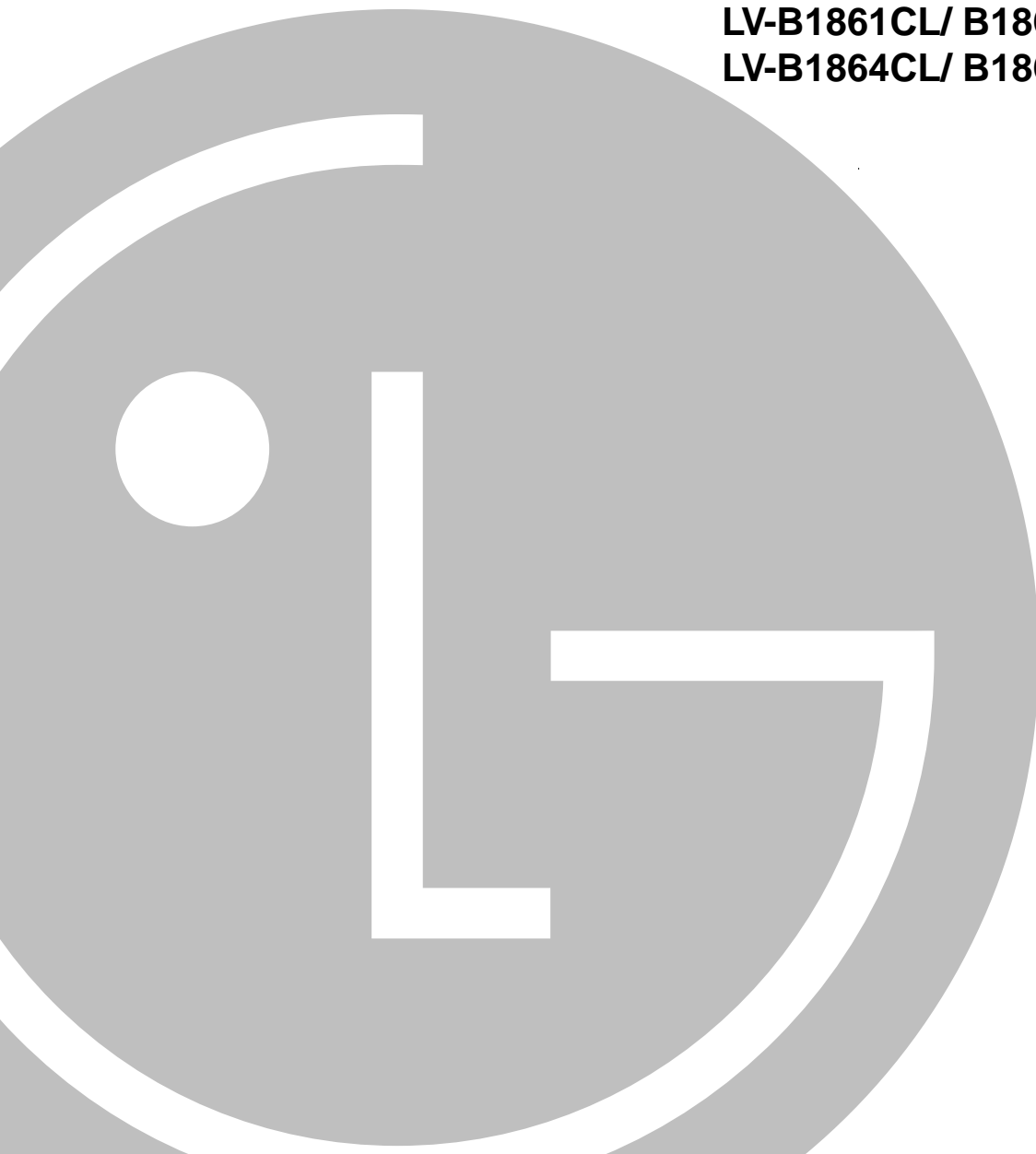

# Contents

---

<b>Functions .....</b>	<b>3</b>
<b>Product Specifications (Cooling Only).....</b>	<b>5</b>
<b>Product Specifications (Cooling &amp; Heating).....</b>	<b>6</b>
<b>Dimensions .....</b>	<b>7</b>
<b>Refrigeration Cycle Diagram .....</b>	<b>9</b>
<b>Wiring Diagram.....</b>	<b>11</b>
<b>Operation Details .....</b>	<b>13</b>
<b>Display Function .....</b>	<b>21</b>
<b>Self-diagnosis Function.....</b>	<b>21</b>
<b>Installation .....</b>	<b>22</b>
<b>Operation .....</b>	<b>39</b>
<b>Disassembly of the parts (Indoor Unit) .....</b>	<b>41</b>
<b>2-way, 3-way Valve.....</b>	<b>45</b>
<b>Cycle Troubleshooting Guide.....</b>	<b>51</b>
<b>Electronic Parts Troubleshooting Guide.....</b>	<b>52</b>
<b>Electronic control device.....</b>	<b>56</b>
<b>Schematic Diagram .....</b>	<b>57</b>
<b>Exploded View and Replacement Parts List.....</b>	<b>58</b>

# Functions

## Indoor Unit

### Operation ON/OFF by Remote controller

### Sensing the Room Temperature

- Room temperature sensor. (Thermistor)

### Room temperature control

- Maintains the room temperature in accordance with the Setting Temp.

### Starting Current Control

- Indoor fan is delayed for 5 seconds at the starting.

### Time Delay Safety Control

- Restarting is inhibited for approx. 3 minutes.

### Indoor Fan Speed Control

- High, Med, Low, Chaos

### Operation indication Lamps (LED)

- ⓪ --- Lights up in operation
- ☆ --- Lights up in Sleep Mode
- ⌚ --- Lights up in Timer Mode
- ✱ --- Lights up in Deice Mode or Hot Start Mode (only Heating Model)
- 💧 --- Lights up during compressor running (only Cooling Model)

### Soft Dry Operation Mode

- Intermittent operation of fan at low speed.

### Sleep Mode Auto Control

- The fan is switched to low(Cooling), med(Heating) speed.
- The unit will be stopped after 1, 2, 3, 4, 5, 6, 7 hours.

### Natural Air Control by CHAOS Logic

- The fan is switched to intermittent or irregular operation
- The fan speed is automatically switched from high to low speed.

### Airflow Direction Control

- The louver can be set at the desired position or swing up and down, right and left (not on all models) automatically.

### Auto Operation

- The setting temperature, indoor fan speed and desired operation made are automatically set by fuzzy rule.

### Deice (defrost) control (Heating)

- Both the indoor and outdoor fan stops during deicing.
- Hot start after deice ends.

### Hot-start Control (Heating)

- The indoor fan stops until the evaporator piping temperature will be reached at 28°C(22°C).

**Remote Controller**

**Operation ON/OFF**



**Operation Mode Selection**

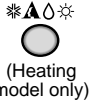
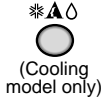

Cooling Operation Mode.( \* )  
Soft Dry Operation Mode.( ∅ )

Auto Operation Mode.( ▲ )  
Heating Operation Mode.( ☀ )

**Fan Speed Selection**

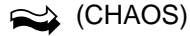
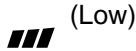

**Room Temperature Display**



: High:39°C LOW:11°C

**Temperature Setting**

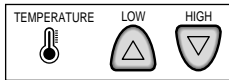

Cooling [ Down to 18°C  
Up to 30°C,

Heating [ Down to 16°C  
Up to 30°C,

**Setting the Time or Timer**



**Timer Selection**

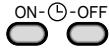

: OFF, ON, OFF ON

**Timer Setting**



**Timer Cancel**



: Cancel Sleep Mode, Timer ON or Timer OFF.

**Sleep Operation**



: 1, 2, 3, 4, 5, 6, 7hr, Off Timer

**Airflow Direction Control**



**Fan Operation Mode**



: Fan Operates without cooling. (Cooling model only)

**Reset**

● RESET

# Product Specifications (Cooling Only)

Item	Model Name		LV-B1861CL	LV-B1864CL	LV-B2461CL	LV-B2464CL
	Unit					
Cooling Capacity	Btu/h(kcal/h)		18,000(4,536)		24,000(6,048)	24,000(6,048)
Moisture Removal	/h		2.5		3.5	3.5
Power Source	ø, V, Hz		1ø, 220-240V, 50Hz			
Air Circulation	Indoor	m <sup>3</sup> /min	14.0		16.0	16.0
	Outdoor		50		50	50
Input	W		1,935	1,850	2,500	2,500
Running Current	A		9.0	9.2	11.9	11.9
E.E.R.	Btu/h-W		9.3	9.7	9.6	9.6
Dimensions (W x H x D)	Indoor	mm	1,200 x 205 x 615			
	Outdoor		870 x 655 x 320			
Net. Weight	Indoor	kg	30			
	Outdoor		57		57	57
Refrigerant (R-22)	g		880	1,050	1,550	1,550
Airflow Direction Control (Up & Down)			O		O	O
Remocon Type			L.C.D Wireless			
Service Valve & Connecting Tube	Liquid		1/4" (6.35)		1/4" (6.35)	1/4" (6.35)
	Gas		1/2" (12.7)		5/8" (15.88)	5/8" (15.88)
Sleeping Operation			O		O	O
Drain Hose			O		O	O
Connecting Wire			0.75mm <sup>2</sup>			
Main Power Cable			1.5mm <sup>2</sup> (2.0mm <sup>2</sup> for the Middle East)		2.5mm <sup>2</sup>	2.5mm <sup>2</sup>
Time Delay Safety Function			O			
Air Circulation			O			
Soft Dry			O			
Fan Speed (Indoor)			3 (Hi, Med, Low)			
Timer			24Hrs			
Self-Diagnosis			O			
Auto-Restart			O			

# Product Specifications (Cooling & Heating)

Item	Model Name		LV-B1861HL	LV-B1864HL	LV-B2461HL	LV-B2464HL
	Unit					
Cooling Capacity	Btu/h(kcal/h)		19,000(4,788)		24,000(6,048)	
Heating Capacity	Btu/h(kcal/h)		20,000(5,040)		24,000(6,048)	
Moisture Removal	/h		2.5		3.5	
Power Source	ø, V, Hz		1ø, 220-240V~, 50Hz			
Air Circulation	Indoor	m <sup>3</sup> /min	14.5		16	
	Outdoor		45		50	
Input	Cooling	W	1,950	1,850	2,670	
	Heating		1,860	1,850	2,570	
Running Current	Cooling	A	8.9	9.2	12.3	
	Heating		8.5	9.2	11.9	
E.E.R.(Cooling)	Btu/h-W		9.74		8.98	
C.O.P.(Heating)	w/w		3.15		2.73	
Dimensions (W × H × D)	Indoor	mm	1,200 x 205 x 615			
	Outdoor		870 x 655 x 320			
Net. Weight	Indoor	kg	30			
	Outdoor		58		58	
Refrigerant (R-22)	g		1,310	1,280	1,390	
Airflow Direction Control (Up & Down)			O		O	
Remocon Type			L.C.D Wireless			
Service Valve & Connecting Tube	Liquid		1/4" (6.35)		1/4" (6.35)	
	Gas		1/2" (12.7)		5/8"(15.88)	
Sleeping Operation			O		O	
Drain Hose			O		O	
Connecting Wire			0.75mm <sup>2</sup>			
Main Power Cable			1.5mm <sup>2</sup> (2.0mm <sup>2</sup> :for the Middle East)		2.5mm <sup>2</sup>	
Time Delay Safety Function			O			
Air Circulation			O			
Soft Dry			O			
Fan Speed (Indoor)			3 (Hi, Med, Low)			
Timer			24Hrs			
Self-Diagnosis			O			
Auto-Restart			O			

# Dimensions

## (1) Indoor Unit

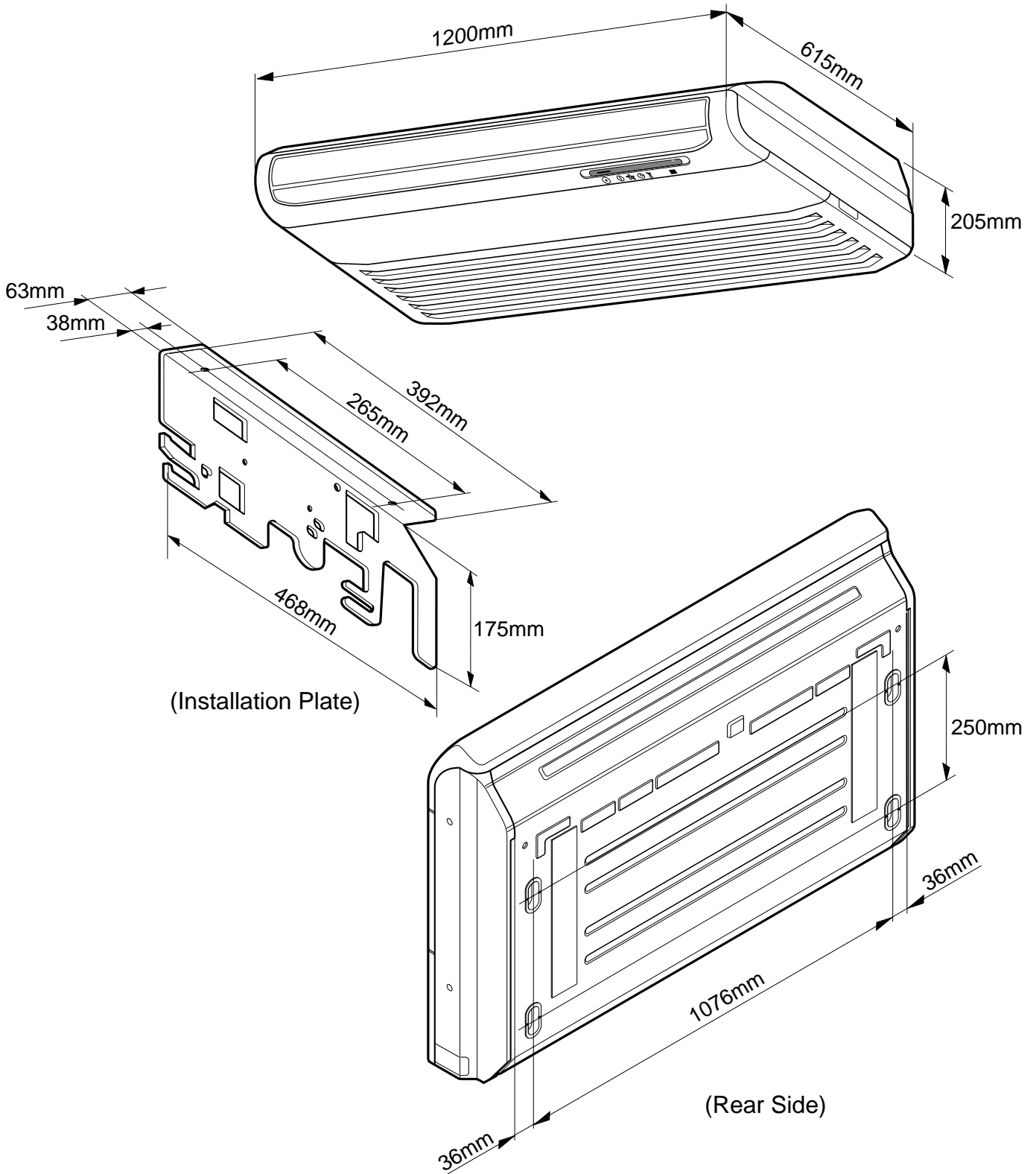

## (2) Outdoor Unit

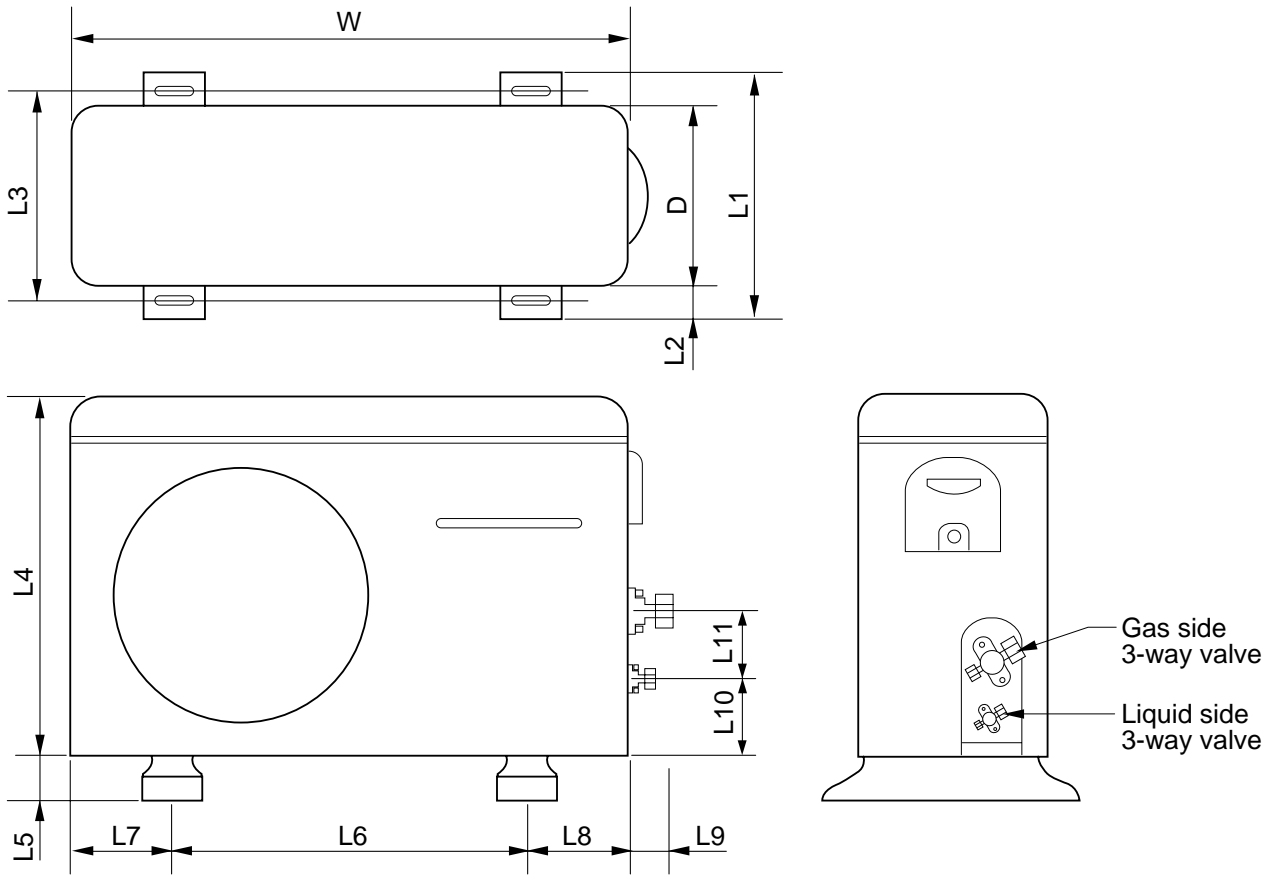

MODEL		LV-B1861CL/HL, LV-B1864CL/HL, LV-B2461CL/HL, LV-B2464HL, LV-B2464CL
DIM		
W	mm	870
H	mm	655
D	mm	320
L1	mm	370
L2	mm	25
L3	mm	340
L4	mm	630
L5	mm	25
L6	mm	546
L7	mm	162
L8	mm	162
L9	mm	54
L10	mm	74.5
L11	mm	79



# Refrigeration Cycle Diagram

- LV-B1861CL
- LV-B1864CL
- LV-B2461CL
- LV-B2464CL

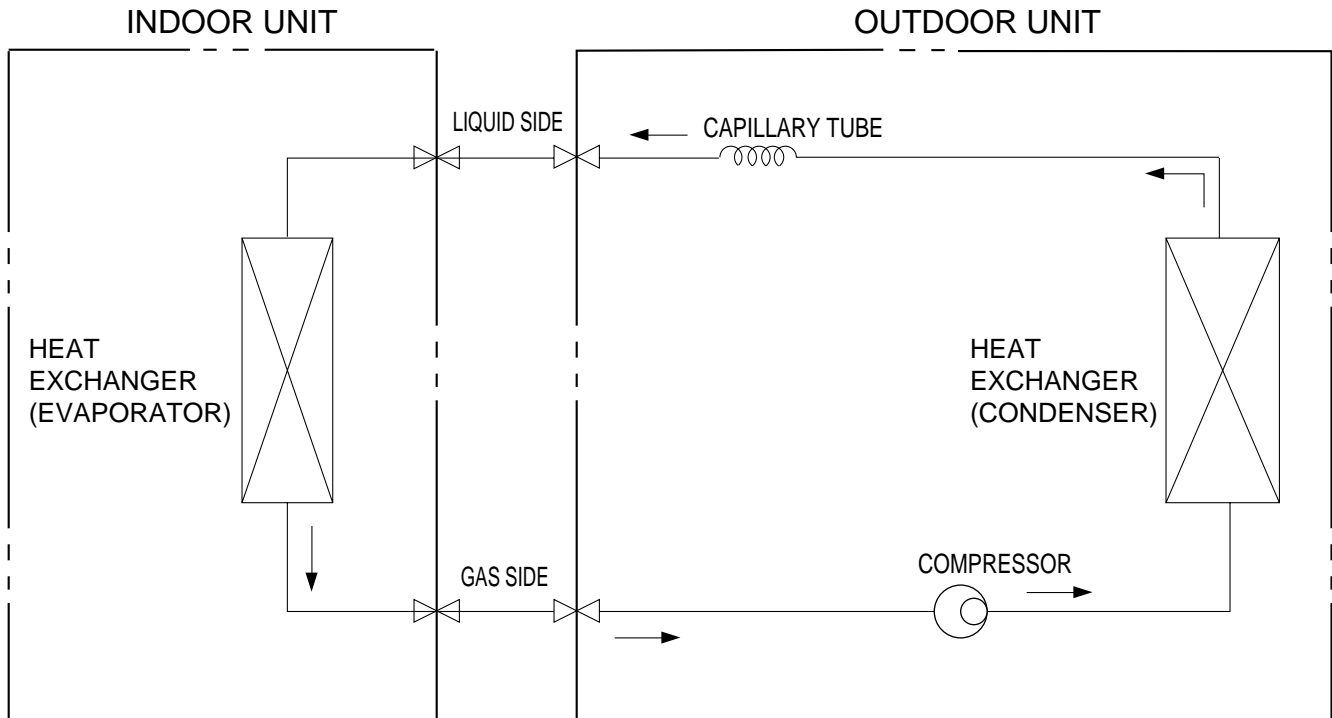

MODEL	Pipe size(Diameter: Ø)		Piping length(m)		Elevation(m)	
	Gas	Liquid	Rated	Max	Rated	Max
LV-B1861CL	1/2"	1/4"	5	15	5	8
LV-B1864CL	1/2"	1/4"	5	15	5	8
LV-B2461CL	5/8"	1/4"	5	20	5	8
LV-B2464CL	5/8"	1/4"	5	20	5	8

For installation over rated distance, 30g of refrigerant should be added for each meter.

ex) When installed at a distance of 15m, 300g of refrigerant should be added.

$$(15-5) \times 30g = 300g$$

- LV-B1861HL
- LV-B1864HL
- LV-B2461HL
- LV-B2464HL

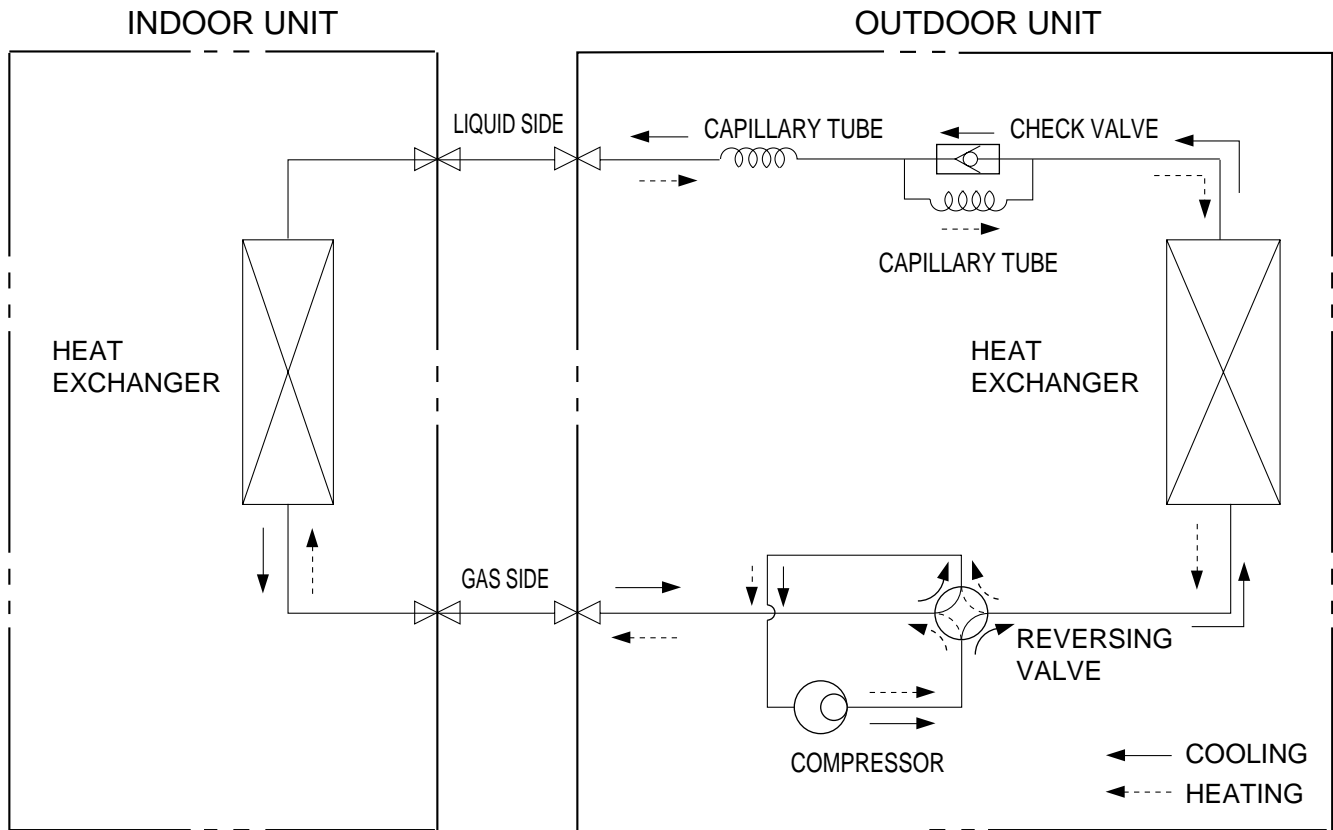

MODEL	Pipe size(Diameter:Ø)		Piping length(m)		Elevation(m)	
	Gas	Liquid	Rated	Max	Rated	Max
LV-B1861HL	1/2"	1/4"	5	15	5	8
LV-B1864HL	1/2"	1/4"	5	15	5	8
LV-B2461HL	5/8"	1/4"	5	20	5	8
LV-B2464HL	5/8"	1/4"	5	20	5	8

For installation over rated distance, 30g of refrigerant should be added for each meter.

ex) When installed at a distance of 15m, 300g of refrigerant should be added.

$$(15-5) \times 30g = 300g$$

# Wiring Diagram

## (1) Indoor Unit

### 1. LV-B1861CL/1864CL/2461CL/2464CL

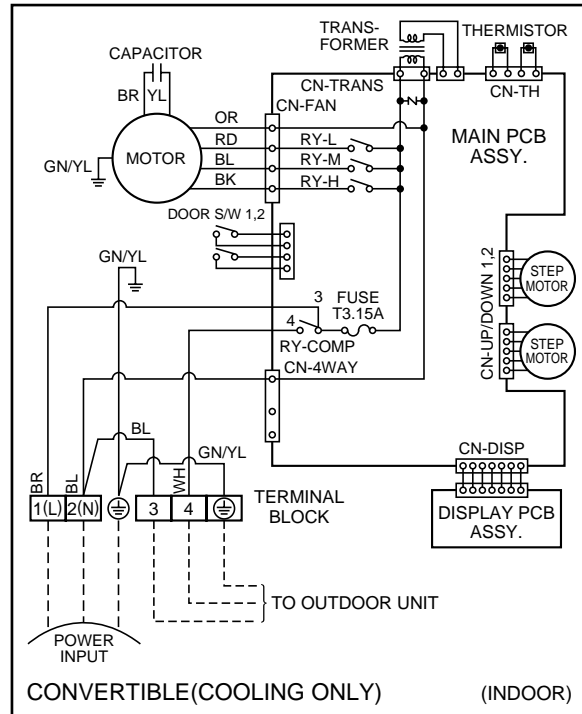

### 2. LV-B1861HL/2461HL

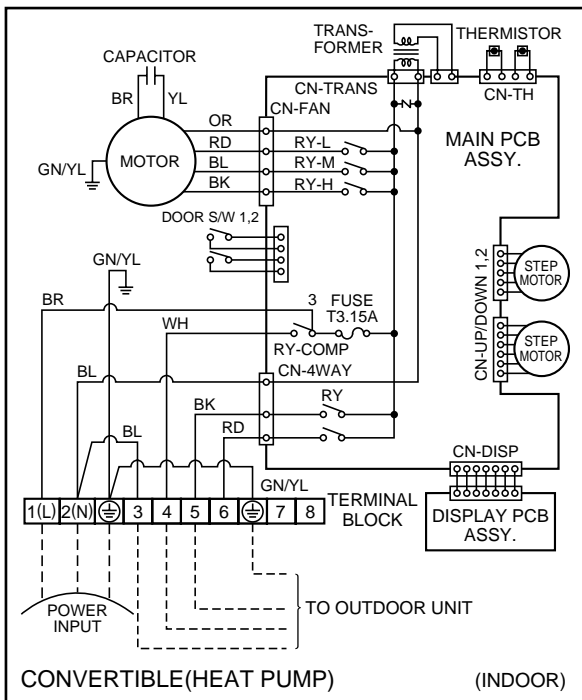

### 3. LV-B1864HL/2464HL

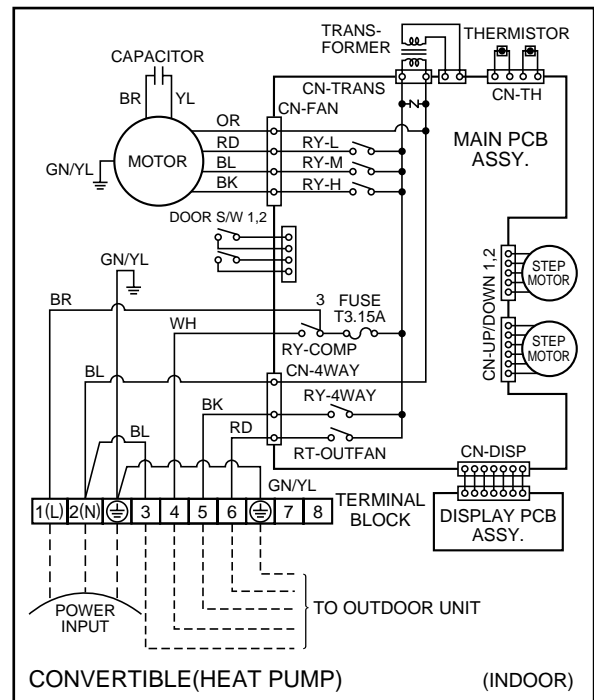

## (2) Outdoor Unit

### 1. LV-B1861CL/1864CL/2461CL/2464CL

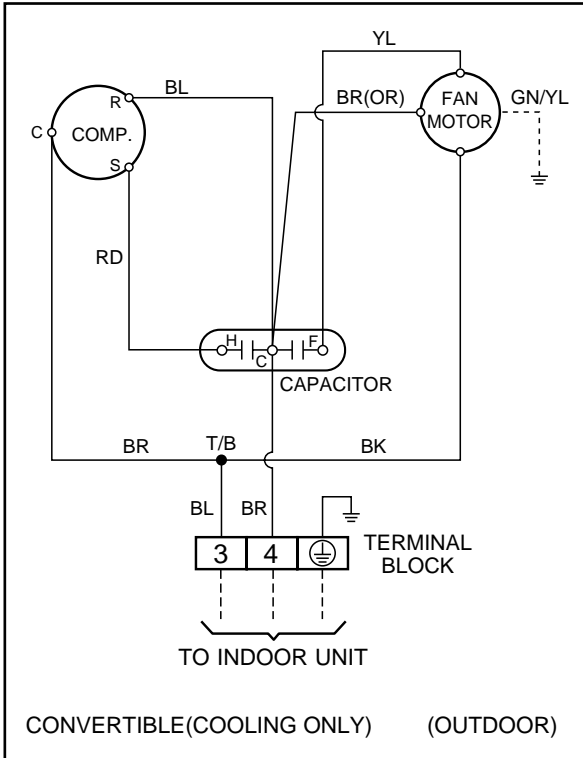

### 2. LV-B2461HL

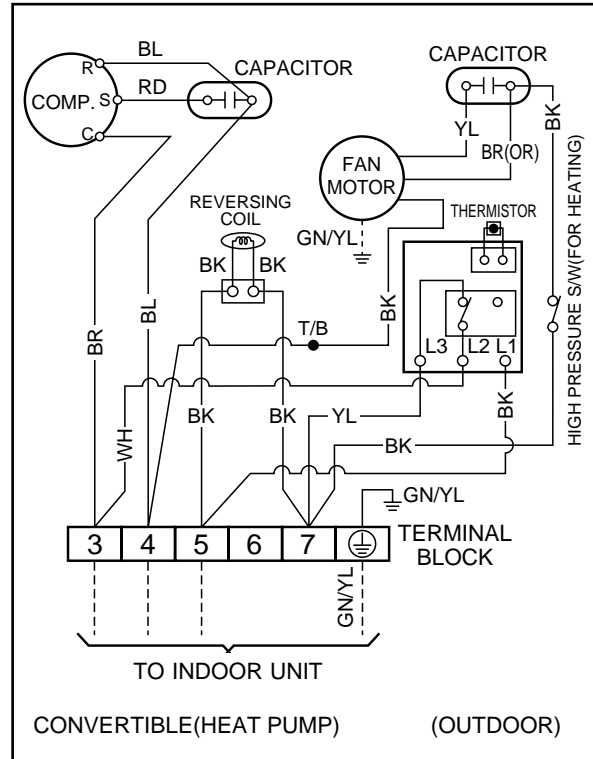

### 3. LV-B1861HL

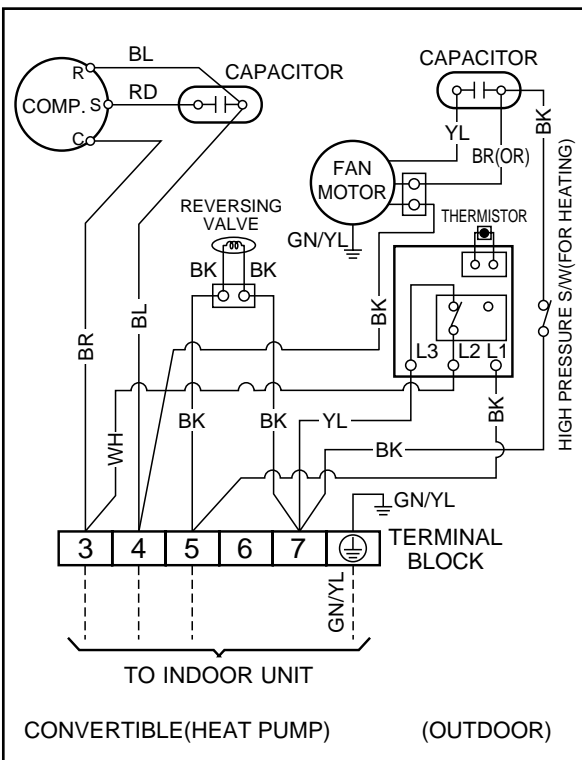

### 4. LV-B1864HL/2464HL

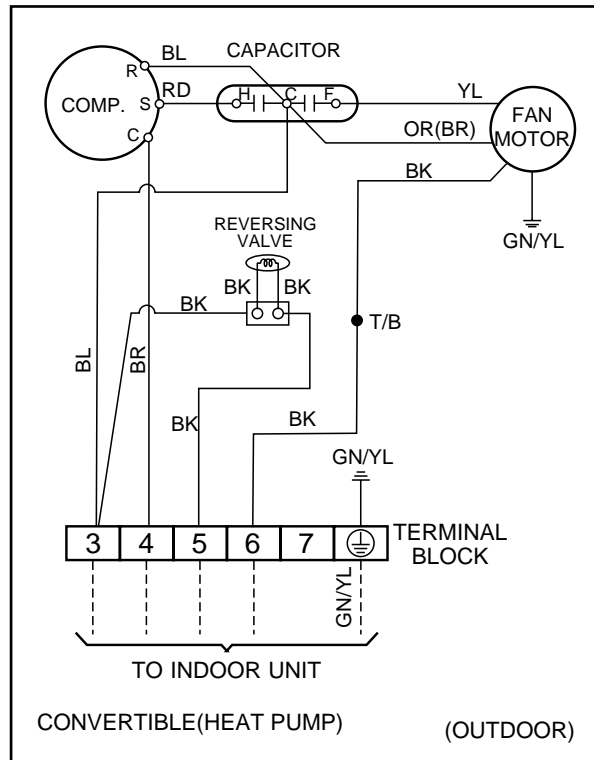

# Operation Details

## (1) The function of main control

### 1. Time Delay Safety Control

- 3min... The compressor is ceased for 3minutes to balance the pressure in the refrigeration cycle.  
(Protection of compressor)
- 5sec... Vertical air flow direction control louvers open in 5 seconds to prevent noise between louvers and wind.
- 30sec... The 4-way valve is ceased for 30sec. to prevent the refrigerant-gas abnormal noise when the Heating operation is OFF or switched to the other operation mode while compress is off.  
While compressor is running, it takes 3~5 seconds to switch.

### 2. Airflow Direction Control

- This function is to swing the louver up and down automatically and to set it at the desired position.
- The procedure is as the following.

1st ; Press the ON/OFF Button to operate the product.

2nd ; Press the Airflow Direction Control Button to swing the louver up and down automatically.

3nd ; Reprress the Airflow Direction Control Button to set the louver as the desired position.

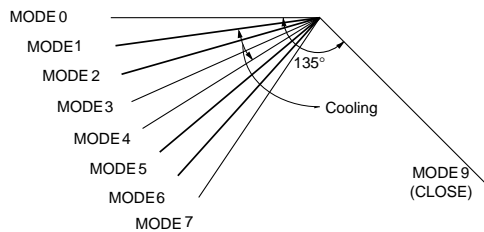

### For Heating Model

- Airflow direction control figure when installed on the floor.

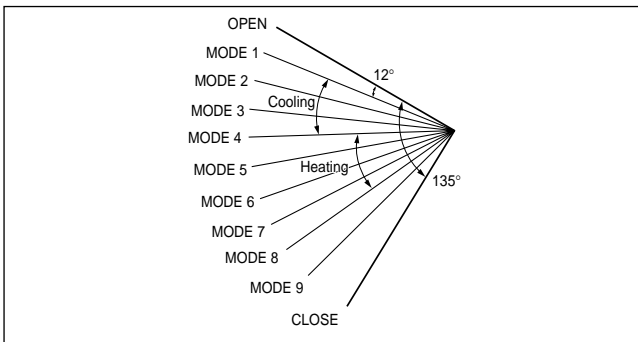

- Airflow direction control figure when installed under the ceiling.

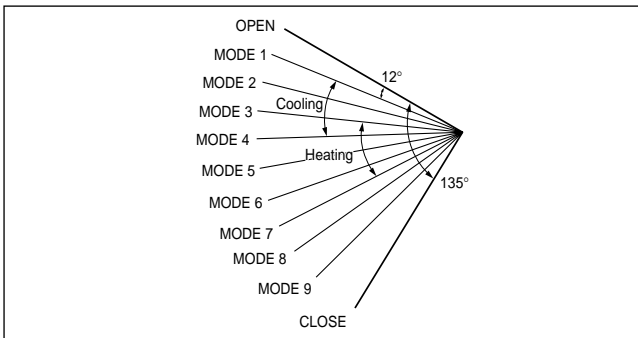
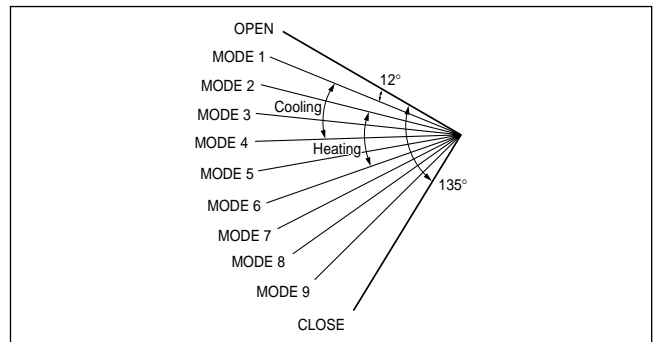

### 3. Cooling Mode Operation

- When selecting the Cooling(☼) Mode Operation, the unit will operate according to the setting by the remote controller and the operation diagram is as following

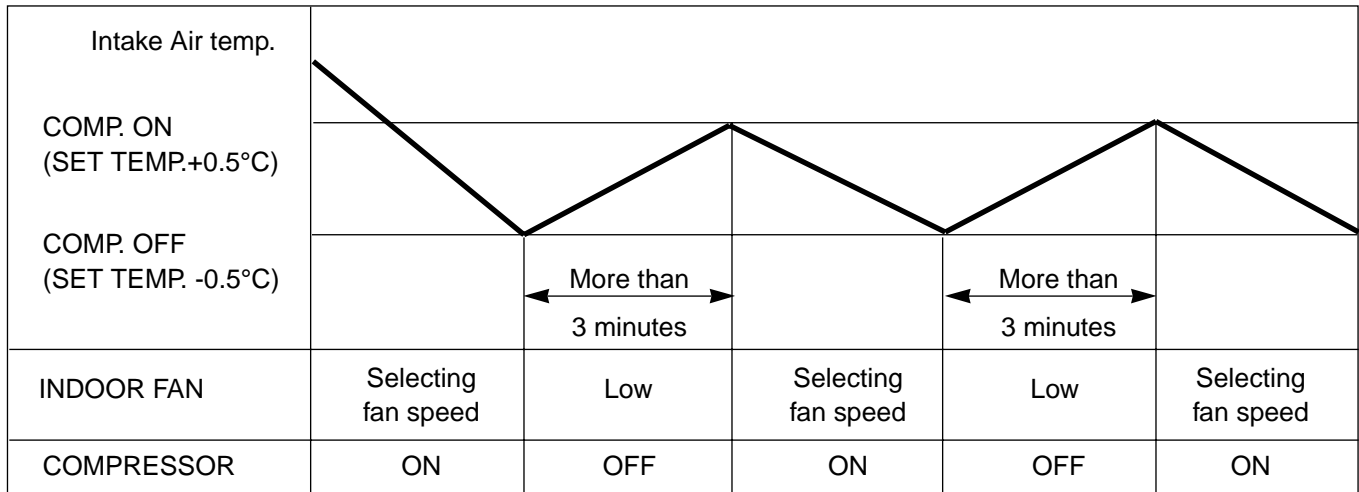

### 4. Cooling or Heating Mode with Sleep Mode Auto Operation

- When selecting the Cooling(☼) or the Heating(☀) combined with the Sleep Mode Auto Operation(▲), the operation diagram is as following.

#### Cooling Mode with the Sleep Mode

- The setting temperature will be raised by 1°C 30minutes later and by 2°C 1 hour later.
- The operation will be stopped after 1, 2, 3, 4, 5, 6, 7 hours.

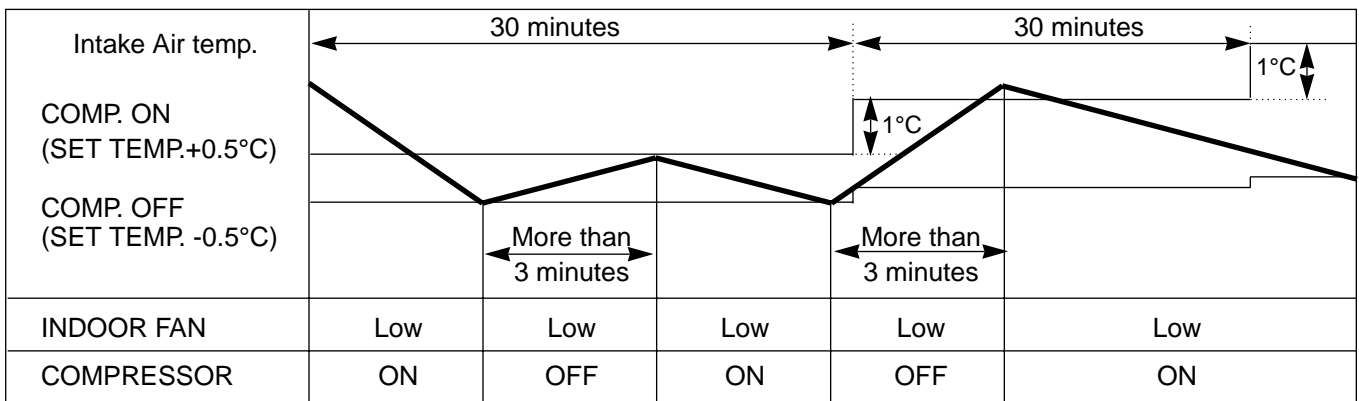

#### Heating Mode with the Sleep Mode.

- The operation will be stopped after 1, 2, 3, 4, 5, 6, 7 hours.

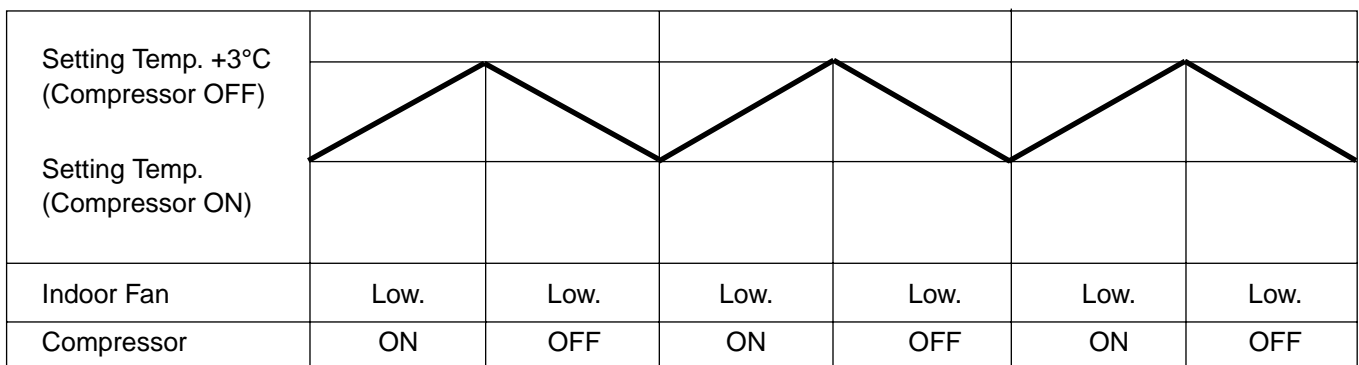

## 5. Auto Operation

- The operation procedure is as following. (Cooling & Heating Model)

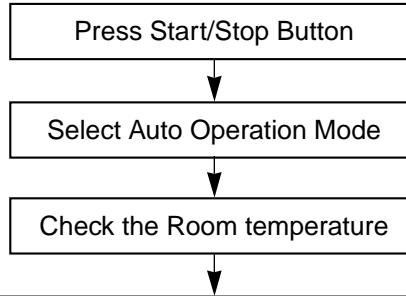

Operation mode Indoor fan speed Setting temperature				are automatically decided by Fuzzy rule.
Intake-air temperature	below 21°C	Over 21°C ~ below 24°C	Over 24°C	
Operation Mode	Heating	Soft Dry	Cooling	

- \* If initial mode is decided, that mode is continued without the room temperature changing.
- \* For cooling operation mode over 24°C setting temperature and fan speed are same as cooling only model.

### • Auto Operation for Cooling. (Cooling only Model)

Operation Condition	Intake-air Temperature	Setting temperature	Fan speed	Air Direction Control
When Auto Operation initial start	Over 26°C	25°C	Controlled by Fuzzy logic	In this mode, when pressing the vertical air direction control. Button, louvers moves to 1/f rhythm (refer to page 17)
	Over 24°C~below 26°C	Intake air -1°C		
	Over 22°C~below 24°C	Intake air -0.5°C		
	Over 20°C~below 22°C	intake air temperature		
	below 20°C	20°C		
When pressing room temperature setting button during Auto Operation	Over 20°C~below 30°C	Fuzzy control		
	below 20°C	20°C		
	over 30°C	30°C		

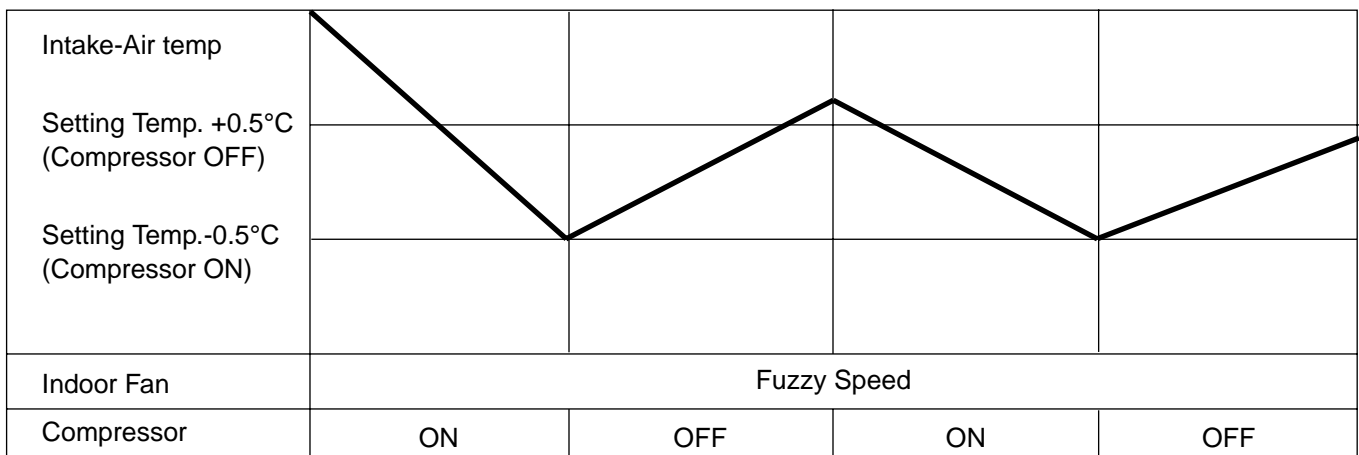

• **Auto Operation for Soft Dry**

The Setting temperature will be same as that of the current intake-air temperature.

- Compressor ON temperature; Setting temperature +1°C
- Compressor OFF temperature; Setting temperature -0.5°C

• **Auto Operation for Heating.**

Intake Air temp.	below 20°C	over 20 ~below 21°C
Setting temp.	20°C	Intake air temp. +0.5°C

- Compressor ON temperature; Setting temperature
- Compressor OFF temperature; Setting temperature +3°C

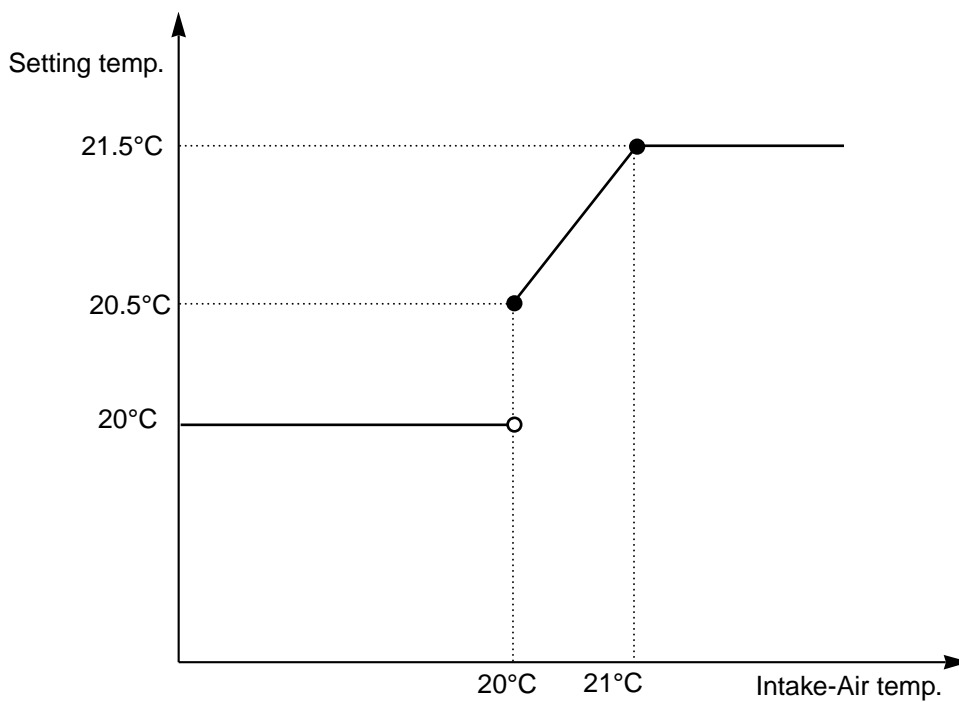

- 1/f rhythm louver operation : In Auto operation mode, when pressing the vertical air direction control button, louver moves as following cycle.

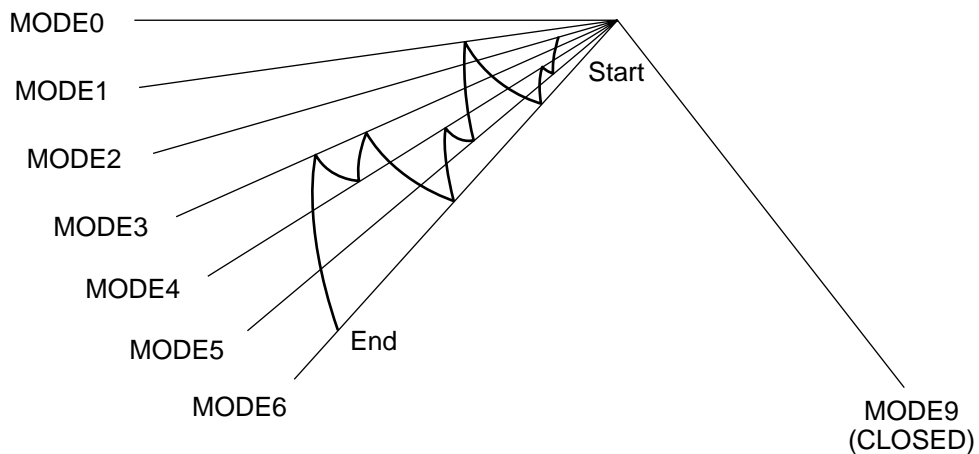





## 7. Heating Mode Operation

The unit will operate according to the setting by the remote controller and the operation diagram is shown as following.

- For Heating Model

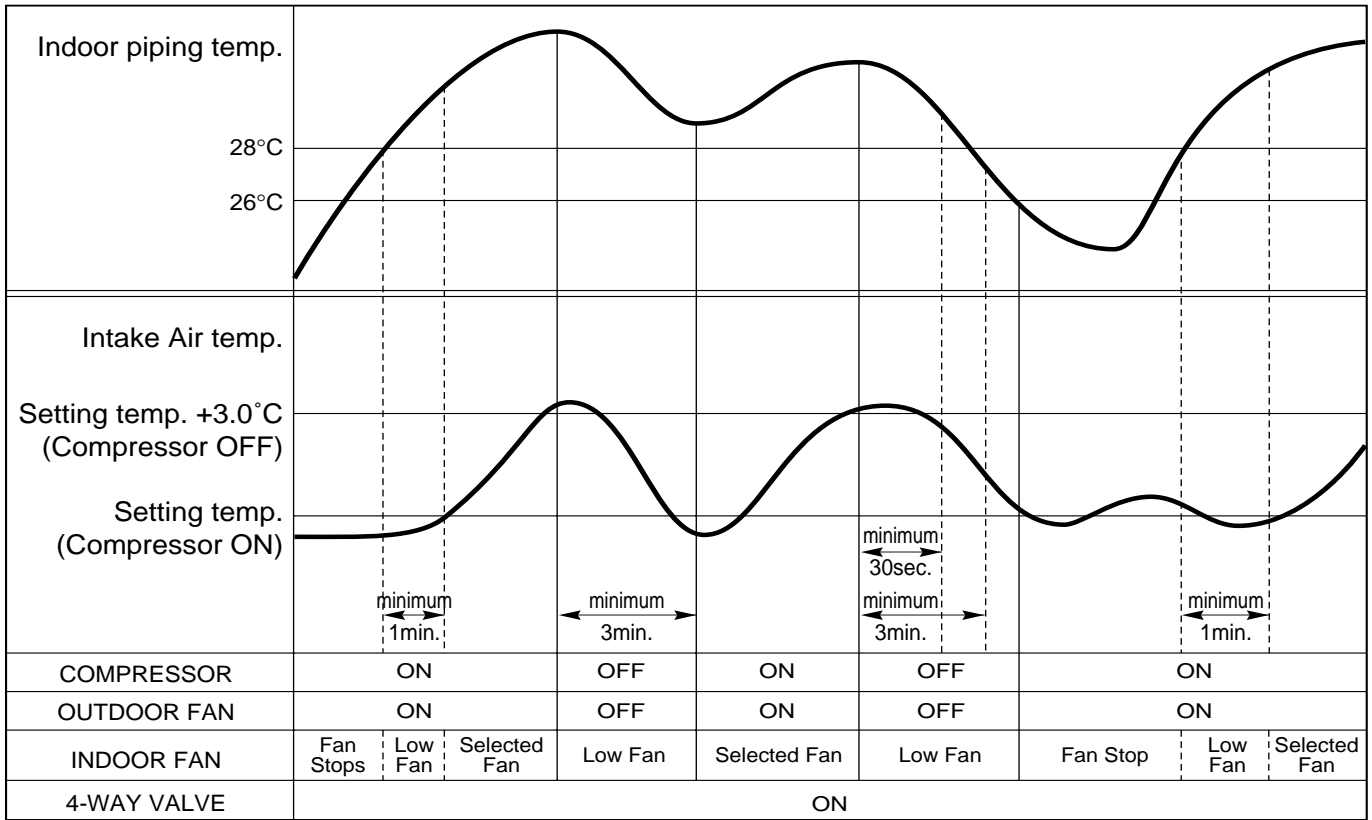

## 8. Hot-Start Control

- The indoor fan stops until the evaporator piping temperature will be reached to 28°C.
- During heating operation, if piping temperatures falls below 26°C fan stops.
- The operation diagram is as following.

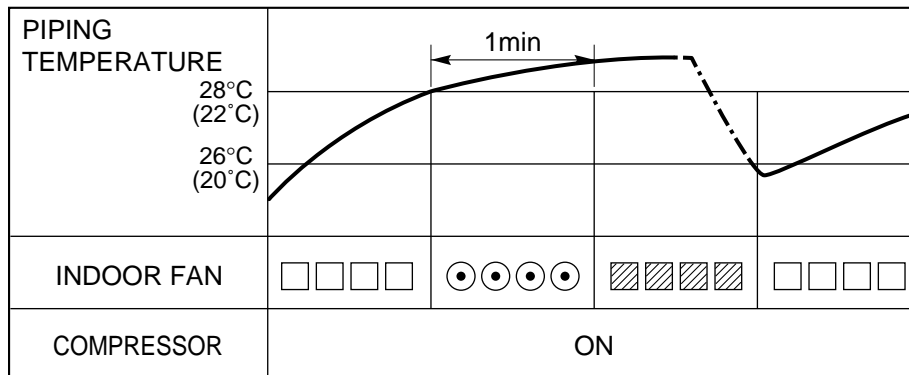

▨ : Selected Fan    ⊙ : Low Fan    □ : Fan Stop

## 9. Deice Control

- Deicing operation is controlled by timer and sensing the outdoor piping temperature.
- The first deicing starts only when the outdoor pipe temperature falls below  $-6^{\circ}\text{C}$  after 45(30) minutes passed from starting of heating operation.
- Deicing ends after 10(6) minutes passed from starting of deice operation or when the outdoor pipe temperature rises over  $12^{\circ}\text{C}$  even if before 10(6) minutes.
- The second deicing starts only when the outdoor pipe temperature falls below  $-6^{\circ}\text{C}$  after 45(30) minutes passed from ending of the first deicing.

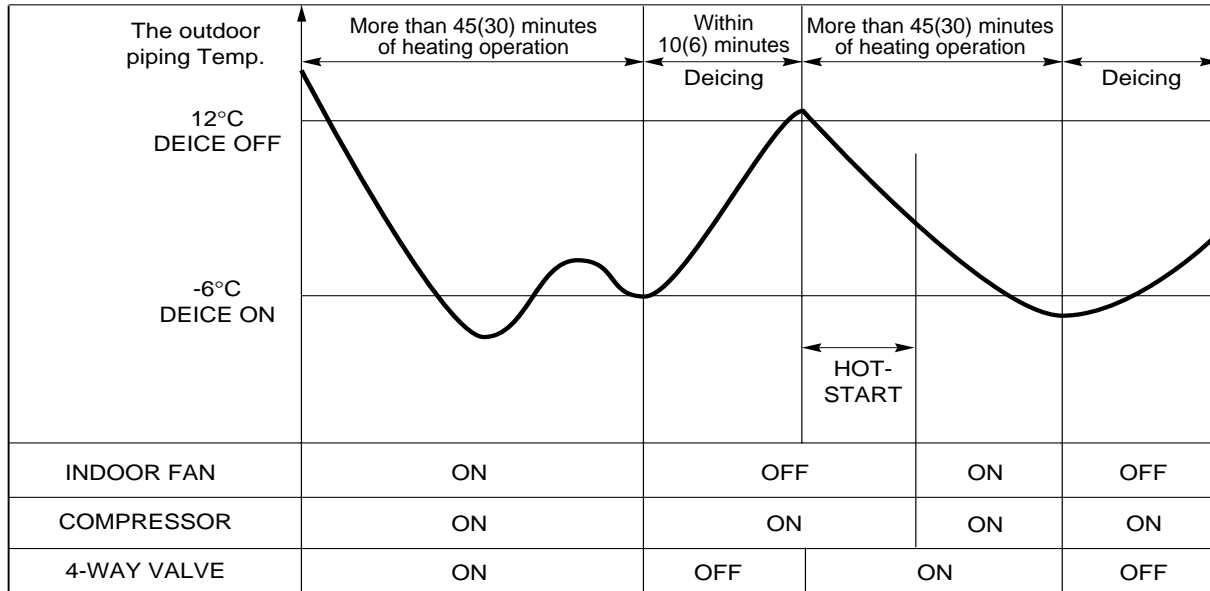

## 10. Soft Dry Operation

- During Soft Dry Operation, the compressor ON temperature is the setting temperature plus  $1^{\circ}\text{C}$ , the compressor OFF temperature is the setting temperature minus  $0.5^{\circ}\text{C}$ .
- When the room temperature rises over the compressor ON temperature, the operation mode is switched to the cooling mode.
- When the room temperature falls between the compressor ON temperature and OFF temperature, the operation mode is switched to the Soft Dry Operation. In this temperature range, 10min. Dry Operation, 7min operation OFF. During 10min Dry operation, if the room temperature falls below compressor OFF temperature, Compressor OFF.
- In micom dehumidify mode, control of fan speed is as following.

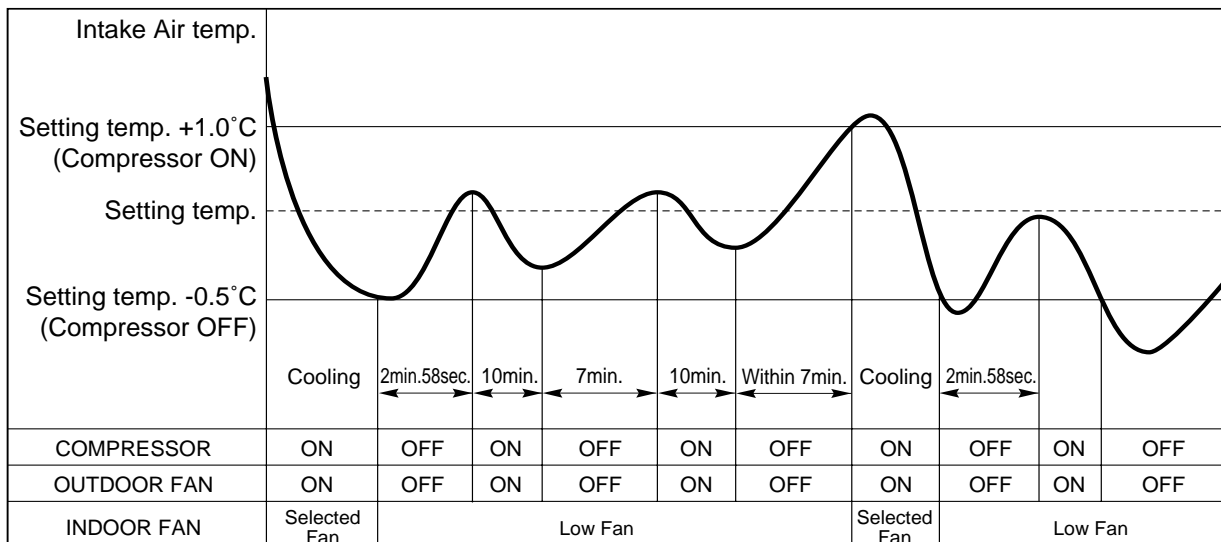

## 11. Forced operation

- If you lose wireless remote controller, you can operate the unit with forced operation switch.
- The standard conditions are as following.

	Cooling Model	Heat pump Model		
		Room Temp 24°C	21°C Room Temp 24°C	Room Temp 21°C
Operation Mode	Cooling	Cooling	Soft Dry	Heating
FAN Speed	High	High	Soft Dry Rule	High
Setting Temp.	24°C	22°C	Air Intake Temperature	24°C

- Unit operates in low fan mode for first 15 seconds, then switched to proper operation mode according to intake Air temperature.

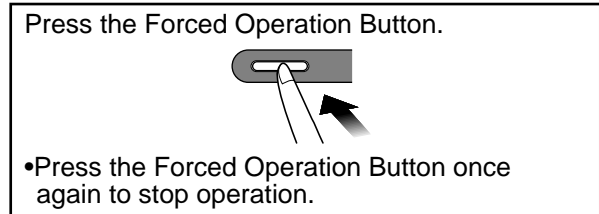
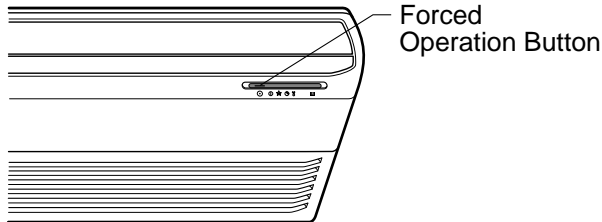

## 12. Protection of the evaporator pipe from frosting

If the temperature of the indoor coil is below 0°C after 7 minutes from starting the compressor, the compressor and the outdoor fan is stopped, and then after 3 minute delay of the compressor and the temperature of the indoor coil is over 7°C, the compressor and the outdoor fan is reoperated. Indoor fan operates at low speed (comp. OFF) or at selected speed (comp. ON)

## 13. Inlet grille open

Once the inlet grille is opened during operation of the unit, the unit automatically stops operation and the lamps will be turned-off. But memorized functions are still available.

When the inlet grille is closed again, the unit become waiting state for operation. From then, the unit can be operated by forced operation button or Start/Stop button of remote controller.

## 14. Test Operation

- When pressing forced operation switch about 3 seconds, the unit operates in cooling mode at high speed fan regardless of room temperature and resets in 18 min.
- During test operation, if remote controller signal is received, the unit operates as remote controller sets.

## 15. Auto Restarting Operation

- When the power is restored after a sudden power failure while in appliance operation, the mode before the power failure is kept on the memory and the appliance should be on the automatically operates in the mode on the memory.
- Operation Mode that is kept on the memory
  - State of Operation ON/OFF
  - Operation Mode/Setting Temp/Selected airflow Speed
  - Sleep Timer Mode/Remaining Time of Sleep Timer(unit of hour)

# Display Function

---

## 1. Heating Model

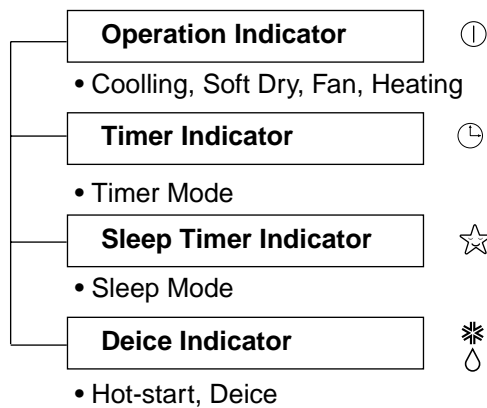

## 2. Cooling Model

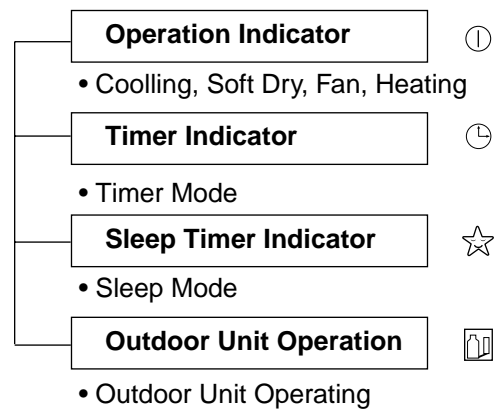

### Note)

For normal operation after checking by test mode, you should press SW1 nine times for resetting or reconnect the power cord.

# Self-diagnosis Function

---

## 1. Protection of the evaporator pipe from frosting

If the temperature of the indoor pipe is below 0°C after 7 mins from starting the compressor, the compressor and the outdoor fan is stopped, and then after 3 mins delay of the compressor and the temperature of the indoor pipe is over 7°C, the compressor and the outdoor fan is reoperated.

## 2. Thermistor Cut Off or Short

Cut Off/Short : Blinks on and off the operation mode LED. (0.5 sec ON/3 sec OFF)

# Installation

## 1. Installation of Indoor, Outdoor Unit

### 1. Selection of the best location

#### 1) Indoor unit

- There should not be any heat source or steam near the unit.
- There should not be any obstacles to prevent the air circulation.
- A place where air circulation in the room will be good.
- A place where drainage can be easily obtained.
- A place where noise prevention is taken into consideration.
- Do not install the unit near the door way.
- Ensure the spaces indicated by arrows from the wall, ceiling, or other obstacles.

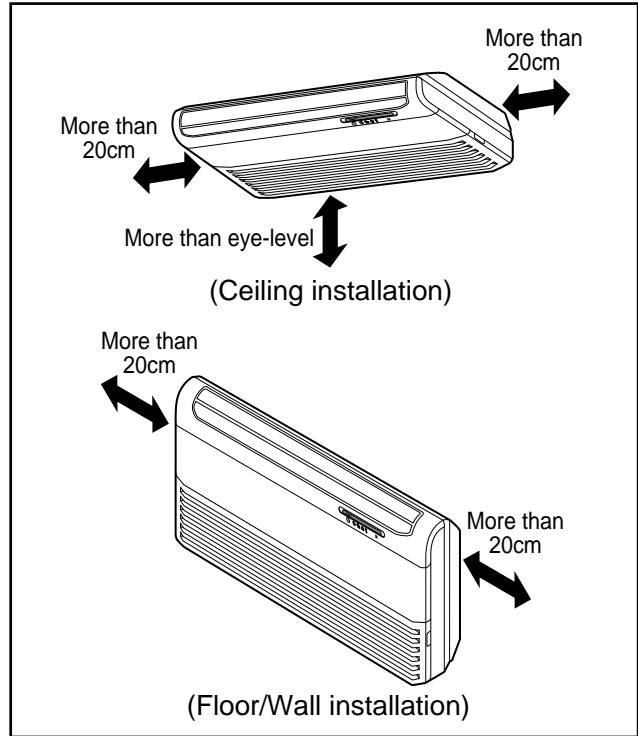

#### 2) Outdoor unit

- If an awning is built over the unit to prevent direct sunlight or rain exposure, be careful that heat radiation from the condenser is not restricted.
- There should not be any animals or plants which could be affected by hot air discharged.
- Ensure the spaces indicated by arrows from the wall, ceiling, fence or other obstacles.

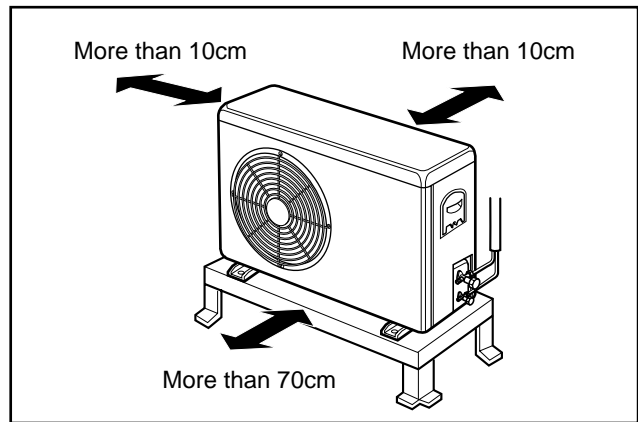

### 3) Piping length and the elevation

MODEL	Pipe Size		Length A(m)		Elevation B(m)		* Additional refrigerant (g/m)
	GAS	LIQUID	Rated	Max.	Rated	Max.	
18K BTU	1/2"	1/4"	7	15	5	8	30
24K BTU	50Hz	5/8"	7	20	5	8	30
	60Hz	5/8"					

- If 18K or 24K Model is installed at a distance of 15m, 240g of refrigerant should be added .....(15-7)x30g

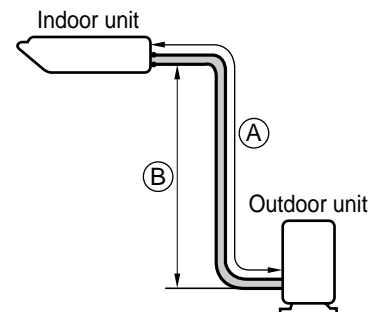

## 2. Indoor unit installation

### ■ Before Installing, prepare Installation Plates

- 'Installation Plates' are attached at the bottom of indoor unit.  
Detach them by removing each 3 screws at both sides.
- Detach 'Side Plate (R,L)' by removing each 2 screws on both sides.
- Pull the upper right and left side of 'Inlet Grille' to the front, and it will stop at slightly tilted position.
- Unhook the 'Inlet hanger' from the 'Hanger screw' on the both left and right side.
- Detach the 'Inlet Grille' from the Indoor Unit.

### 1) Installation on the ceiling

- Measure and mark the position for the Suspension bolts and the piping hole.
- Drill the hole for anchor nut on the ceiling.

Before secure the Installation Plates, select the bent direction of the Installation Plate to the inside or the outside according to the installation circumstances.

- Drill the piping hole on the wall slightly tilted to the outdoor side using a  $\varnothing 70$  hole-core drill.

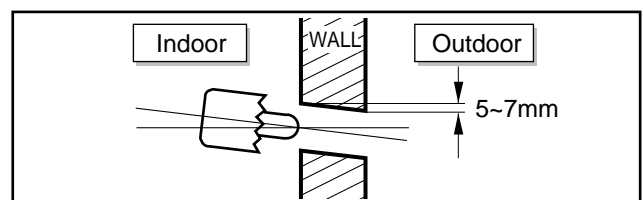
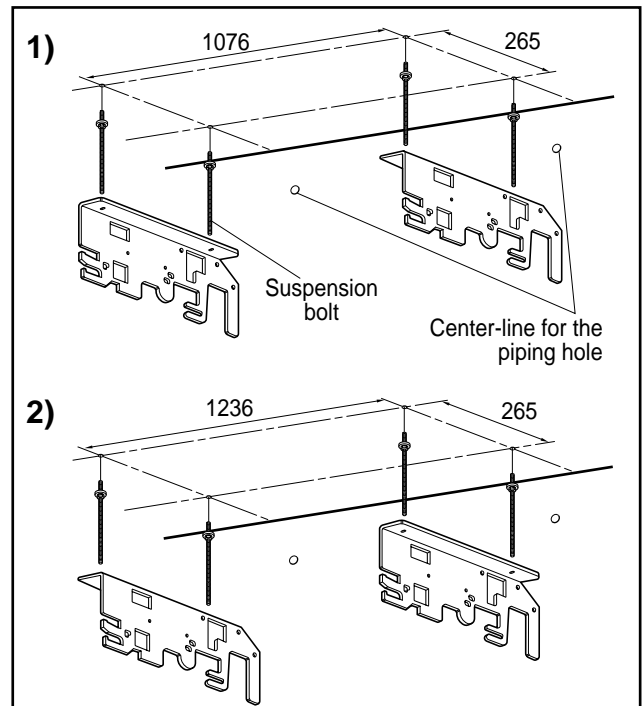
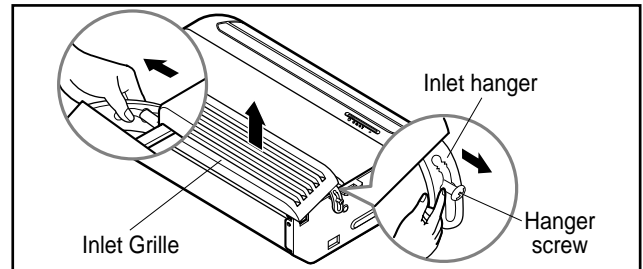
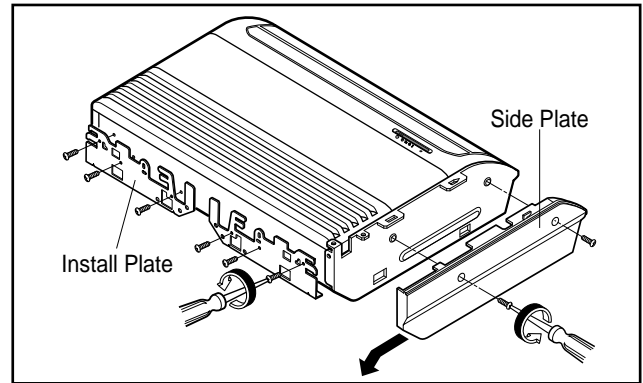

- Insert the nuts and washer onto the suspension bolts for locking the suspension bolts on the ceiling.
- Mount the suspension bolts to the anchor-nuts firmly.
- Secure the Installation plates onto the Suspension bolts (adjust level roughly.) using nuts, washers and spring washers.

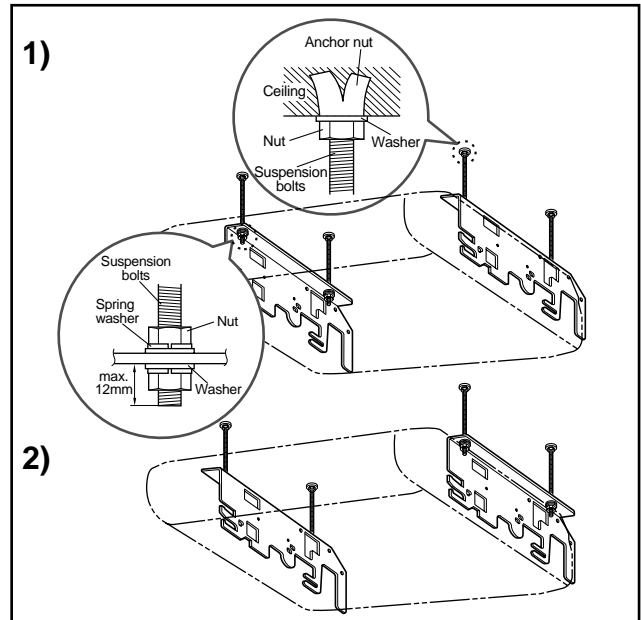

- Engage 2 hooks on the both left and right side of the unit to the lower slot of Installation Plates.
- Adjust a level with a level gauge on the direction of left-right, back-forth by adjusting suspension bolts.
- Move the hooks on the unit to the upper slot of Installation Plates. Then the unit will be declined to the bottomsides so as to drain well.

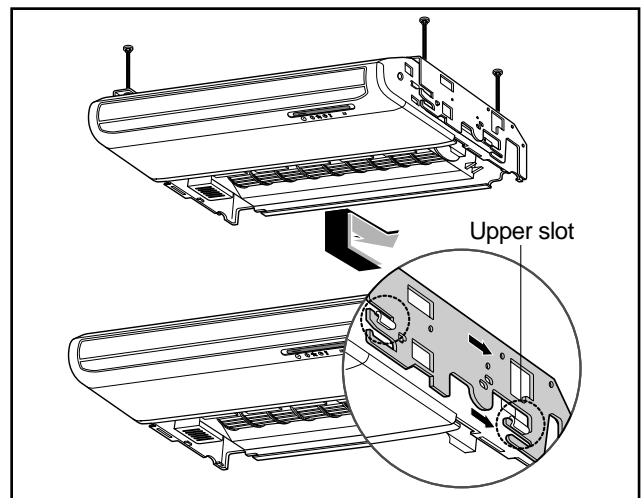
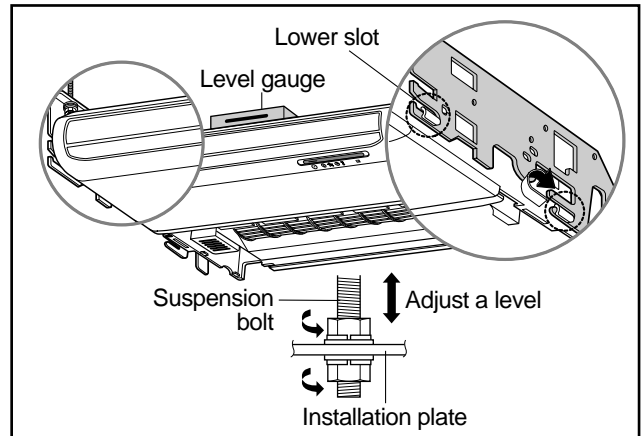



## CAUTION

1. **Install declination** of the indoor unit is very **important for the drain** of the convertible type air conditioner.
2. Minimum thickness of the insulation for the connecting pipe shall be 7mm.
3. If the Installation Plates are fixed to horizontal line, the indoor unit after installing will be declined to the bottomside.

### Front of view

- The unit must be horizontal or declined to the drain hose connected when finished installation.

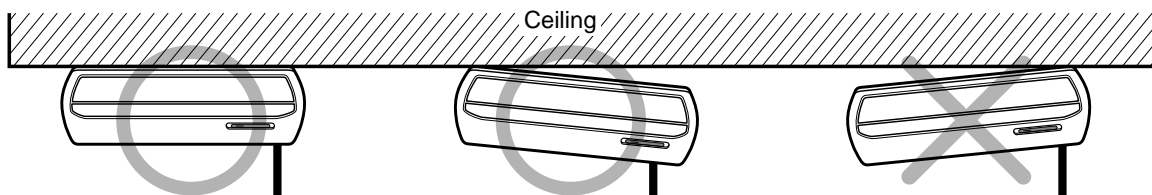
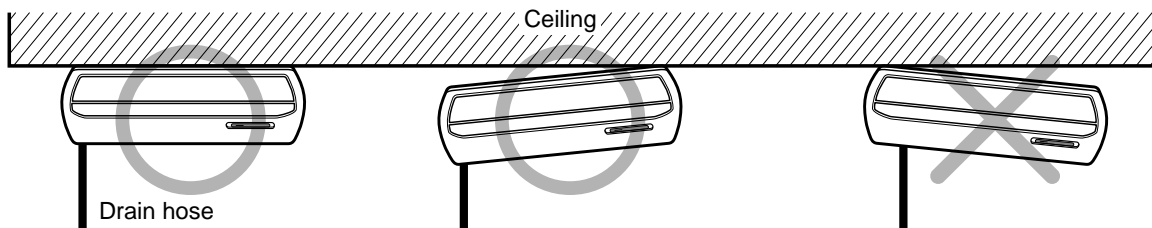

### Side of view

- The unit must be declined to the bottomside of the unit when finished installation.

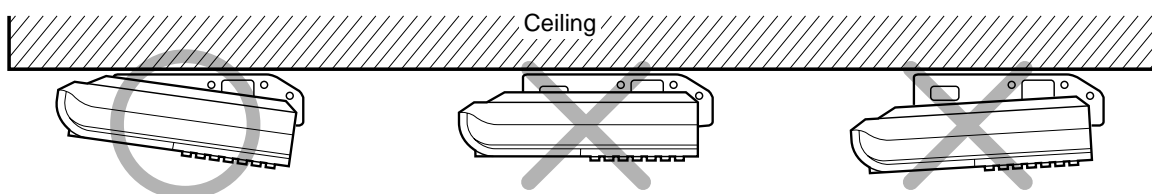

- Secure the unit to the Installation Plates with four M8 bolts and washers.

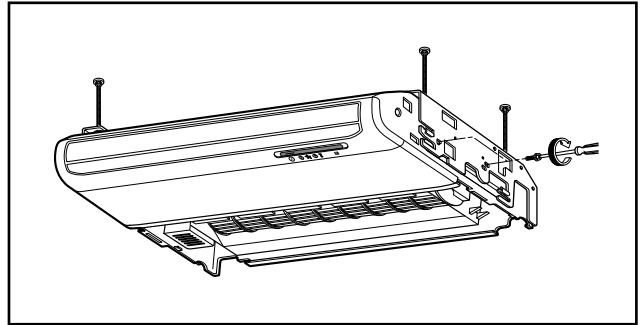

- Before working, refer to "Connecting pipe and cable to Indoor Unit" on page 32.

- Hook up the Inlet Grille Hook to the cabinet.
- Hang the Inlet Hanger to the screw.

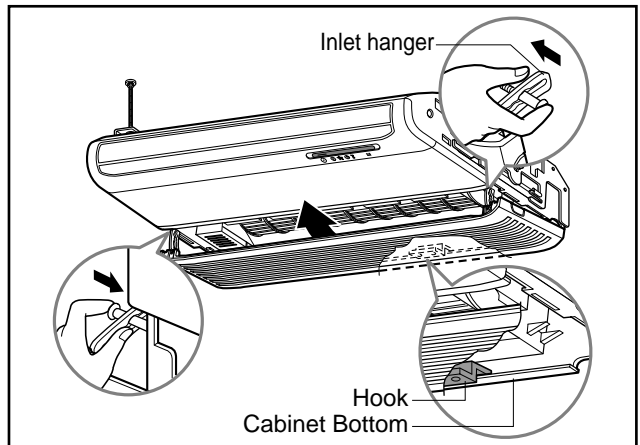

- Fit the projection hooks of the side plates to the 'Side Panel' and the 'Front Panel' by lifting it.
- Fasten the screws.

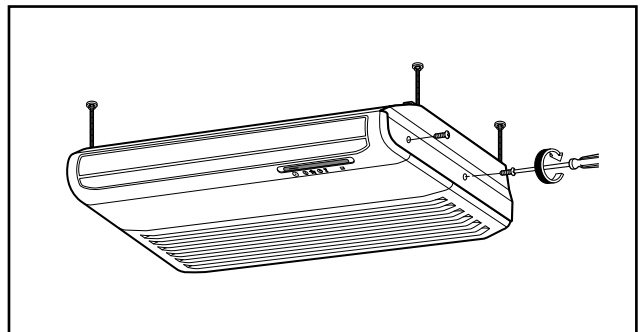
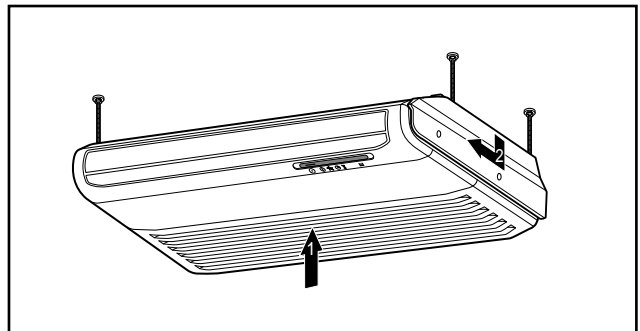

## 2) Installation on the Wall

- Select and mark the position for fixing bolts and piping hole.  
Decide the position for fixing bolts slightly tilted to the drain direction after considering the direction of drain hose.
- Drill the hole for anchor nut on the wall.

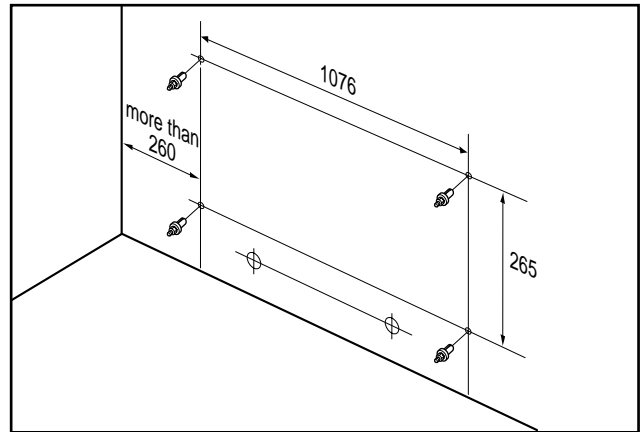

- Drill the piping hole on the wall slightly tilted to the outdoor side using a  $\varnothing 70$  hole-core drill.

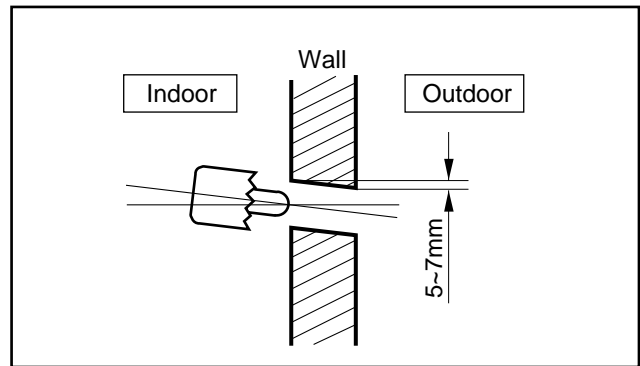

- Secure the 'Install Plate' onto the wall with four anchor bolts, washers and spring washers.

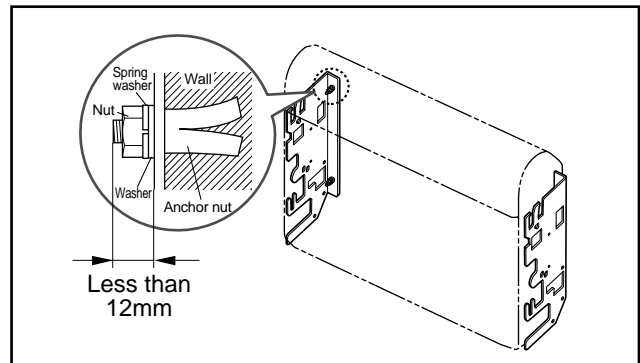

Before secure the Install Plates, select the bent direction of the 'Install Plate' to the inside or outside according to the installation circumstances.

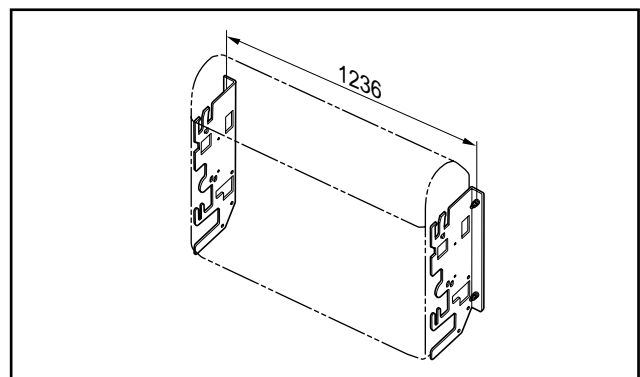

Install the Indoor unit onto Installation Plate.

- Insert 2 hooks on the both left and right side of the unit to the inner slot (wall side) of the Installation Plate.
- Secure the unit to the Installation Plate with four M8 bolts and washers.

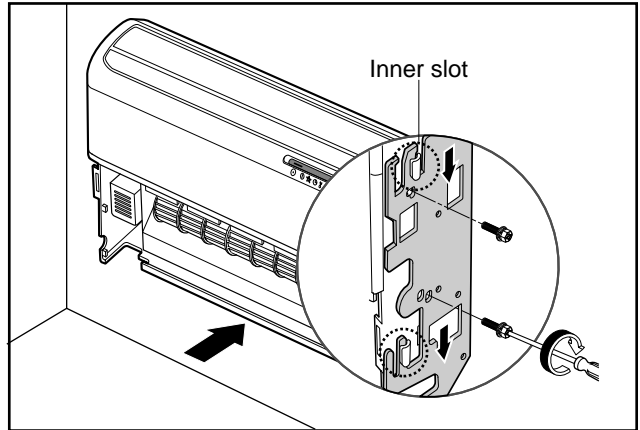

- Before working, refer to "Connecting pipe and cable to Indoor Unit" on page 32.

- Hook up the Inlet Grille Hook to the cabinet.
- Hang the Inlet Hanger to the screw.

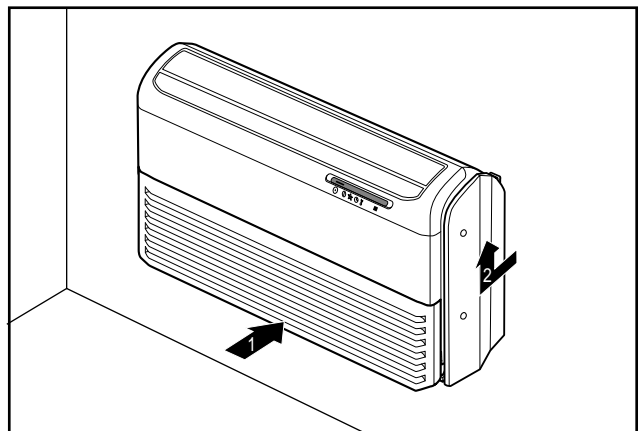

- Fit the projection hooks of the side plates to the 'Side Panel' and the 'Front Panel' by lifting it.
- Fasten the screws.

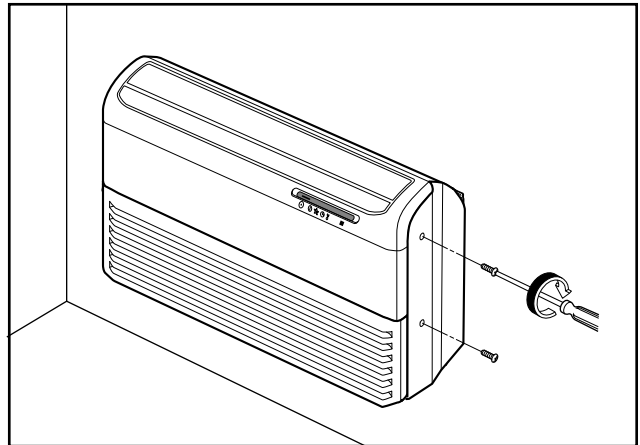

### 3) Installation on the floor

Installation of Mount Bracket.

- Select and mark the position for Mount Brackets and the piping hole.
- Drill the hole for the anchor nut on the wall.
- Drill the piping hole using a  $\varnothing 70$  hole-core drill.
- Secure the Mount Brackets on the wall with four M4 screws.

Install the indoor unit onto the Mount Brackets.

- Engage the slot at the back of the unit with Mount Bracket.

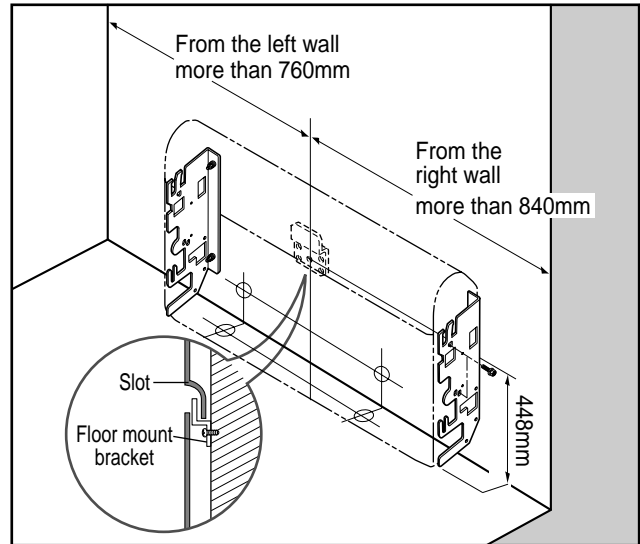

- Drill the piping hole with 70mm dia, hole core drill.
- Piping hole should be slightly slant to the outdoor side.

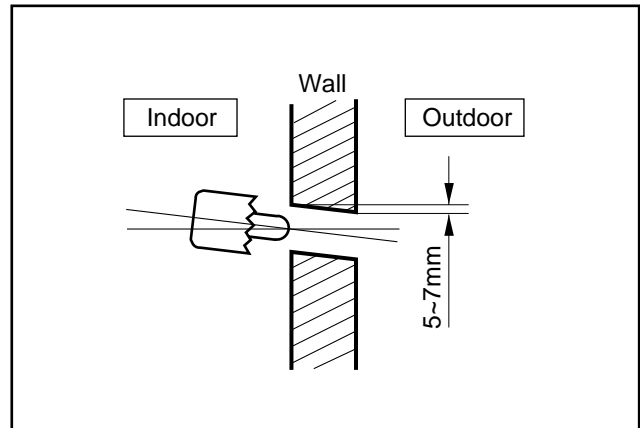

**After Installing, reassemble detached parts.**

- Hang the 'Inlet Grille' and hook the 'Inlet Hanger' to the Hanger Screw.
- Assemble the 'Side Plates(R,L)' with 2 screws on both left and right side.

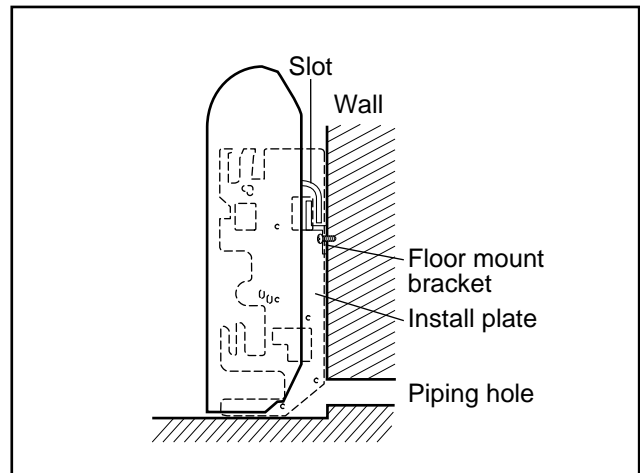

## 3. Connecting Pipes to the Indoor Unit

### 3-1. Preparation of Piping

Main cause of gas leakage is defect in flaring work. Carry out correct flaring work in the following procedure.

#### 1) Cut the pipes and the cable.

- Use the accessory piping kit or the pipes purchased locally.
- Measure the distance between the indoor and the outdoor unit.
- Cut the pipes a little longer than measured distance.
- Cut the cable 1.5m longer than the pipe length.

#### 2) Burrs removal

- Completely remove all burrs from the cut cross section of pipe/tube.
- Put the end of the copper tube/pipe to downward direction as you remove burrs in order to avoid to let burrs drop in the tubing.

#### 3) Putting nut on

- Remove flare nuts attached to indoor and outdoor units, than put them on pipe/tube having completed burr removal.  
(Not possible to put them on after flaring work)

#### 4) Flaring work

- Carry out flaring work using flaring tool as shown below.

Outside diameter		A
mm	inch	mm
Ø12.7	1/2	0 ~ 0.5
Ø15.88	5/8	0 ~ 1.0

Firmly hold copper tube in a die as indicated dimension in the table above.

#### 5) Check

- Compare the flared work with figure below.
- If flare is noted to be defective, cut off the flared section and do flaring work again.

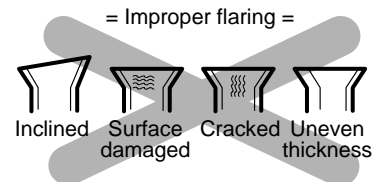
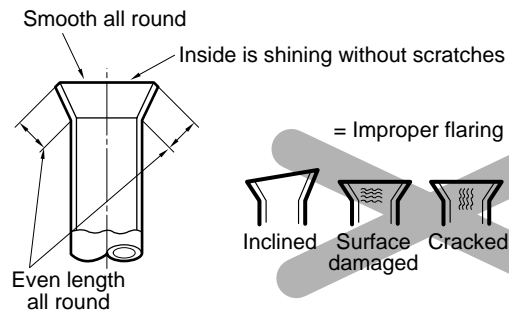
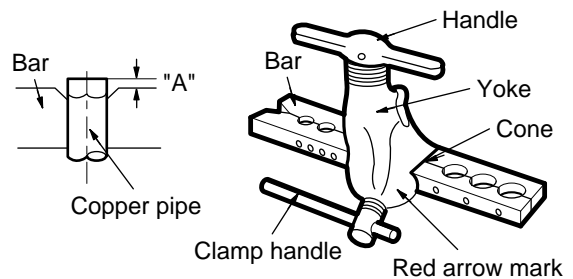
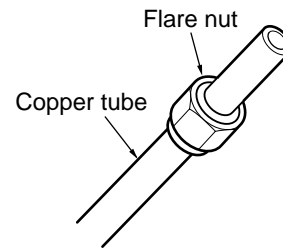
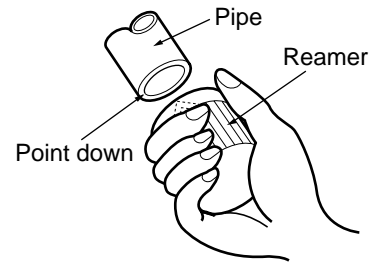
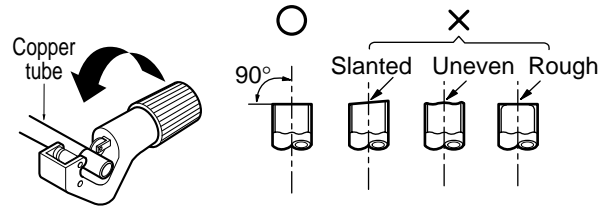

## 3-2. Installation on the ceiling

### 1) Connecting the pipes to the indoor unit

The pipe can be connected to right side, bottom or back of the unit.

#### 1. For the Right Side Piping

- After bending an end of the connecting tube, align the center of the pipings and sufficiently tighten the flare nut with fingers.
- Finally, tighten the flare nut with torque wrench until the wrench clicks.
- Connect the Drain Hose insulated to the drain outlet. Drain hose should be go through under the Hose Bracket as shown in figure .
- Hang the drain hose on the hose hanger and fix it to the hole of the hose bracket with a screw.

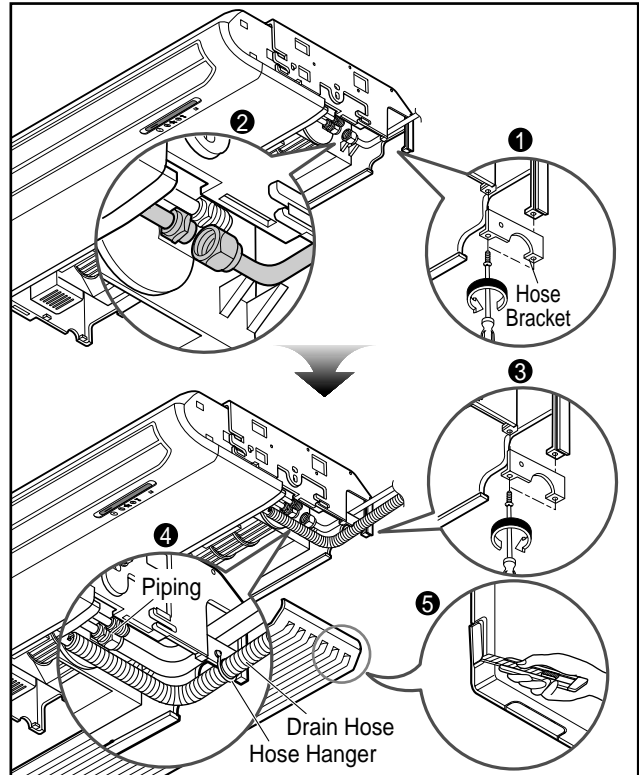

#### 2. For the Bottom Side Piping

- Remove the knock-out on the bottomsides of Inlet Grille
- Align the center of the pipings and sufficiently tighten the flare nut with fingers.
- Finally, tighten the flare nut with torque wrench until the wrench clicks.
- Connect the Drain Hose insulated to the drain outlet.
- Hang the drain hose on the hose hanger and fix it to the hole of cabinet bottom with a screw.

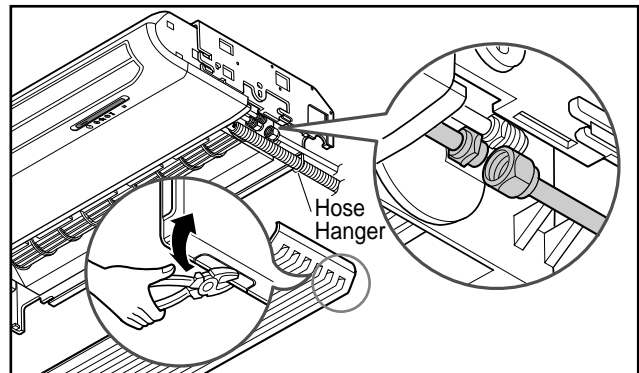

### 2) Connecting the Drain Hose

- The drain hose can be connected to not only the right side but also left side of the unit.
- If the drain hose is connected to the left side, it should go through the cabinet bottom.
- Hang the drain hose on the hose hanger and fix it to the hole of cabinet bottom with a screw.

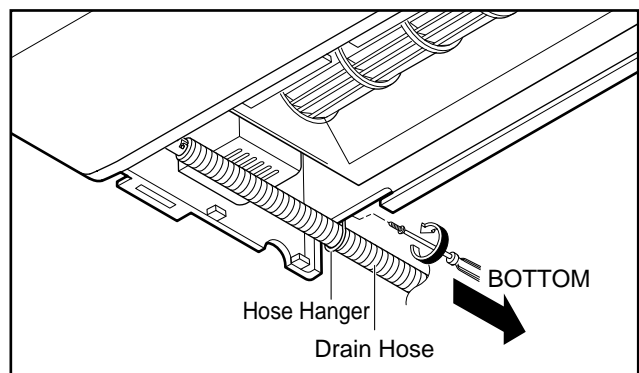

### 3-3. Installation on the wall or floor

#### 1) Connecting the pipes to the indoor unit

##### 1. For the Right Rear Piping

- Remove the knock-out at the back side of the cabinet.
- After bending an end of the connecting tube, align the center of the pipings and sufficiently tighten the flare nut with fingers.
- Finally, tighten the flare nut with torque wrench until the wrench clicks.
- Connect the Drain Hose insulated to the drain outlet.
- Tape the Drain Hose to the pipings to avoid coming off the drain-outlet.

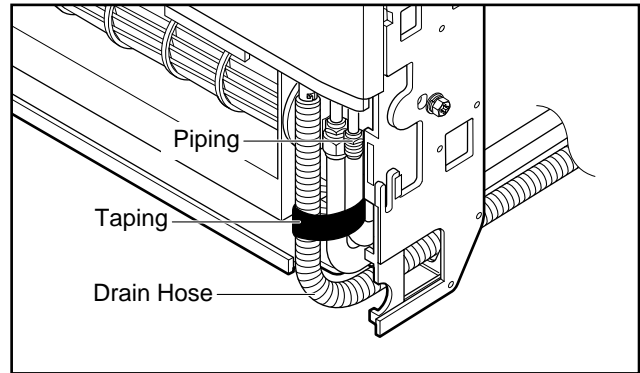

##### 2. For the Right Side Piping

- After bending an end of the connecting tube, align the center of the pipings and sufficiently tighten the flare nut with fingers.
- Finally, tighten the flare nut with torque wrench until the wrench clicks.
- Connect the Drain Hose insulated to the drain outlet.
- Tape the Drain Hose to the pipings to avoid coming off the drain-outlet.

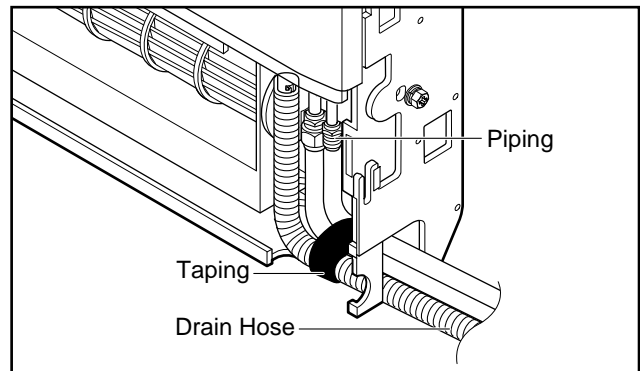

##### 3. For the Right Bottom Piping

- Align the center of the pipings and sufficiently tighten the flare nut with fingers.
- Finally, tighten the flare nut with torque wrench until the wrench clicks.
- Connect the Drain Hose insulated to the drain outlet.

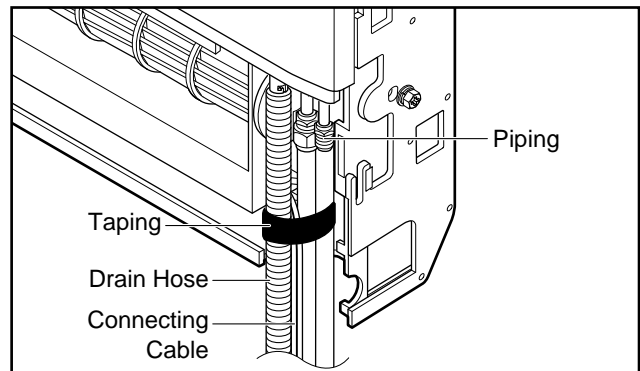

#### 2) Connecting the Drain Hose

- The drain hose can be connected to not only right side but also left side of the unit.

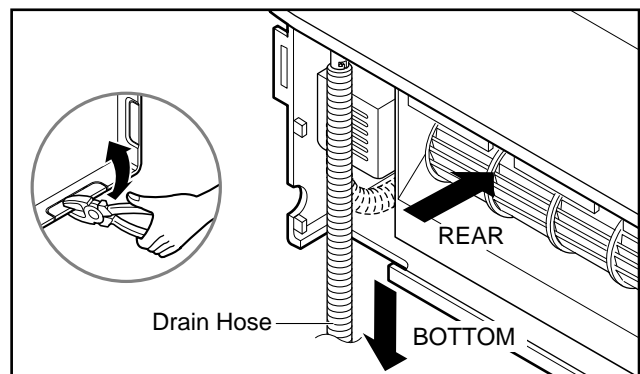



## 4. Connecting Pipes to the Outdoor Unit

### 1) Connecting the pipes to the Outdoor unit

1. Align the center of the pipings and sufficiently tighten the flare nut with fingers.
2. Finally, tighten the flare nut with torque wrench until the wrench clicks.
  - When tightening the flare nut with torque wrench, ensure the direction for tightening follows the arrow on the wrench.

Pipe Size		Torque
Liquid Side	1/4"	1.8kg·m
	3/8"	4.2kg·m
Gas Side	1/2"	5.5kg·m
	5/8"	6.6kg·m

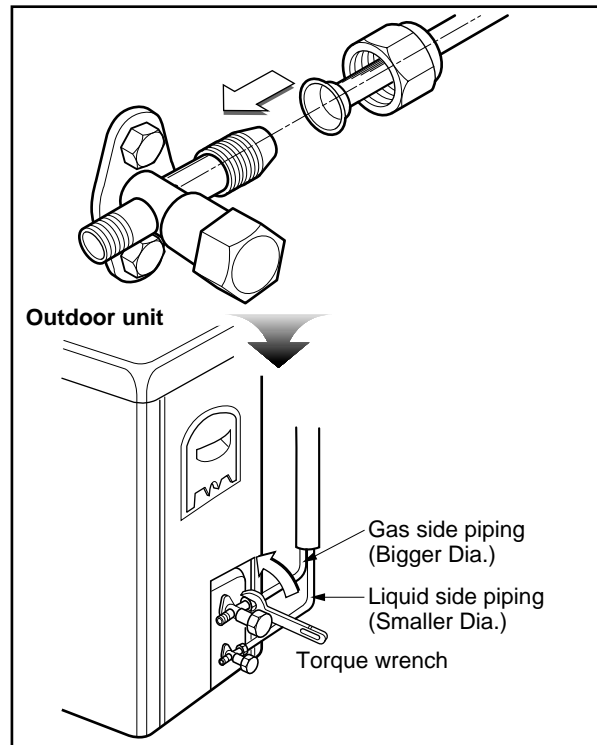

## 5. Checking the Drainage

### 1) Checking the Drainage

1. Remove the Air Filter.
  - To remove air filter, take hold of tab and pull slightly upwards.

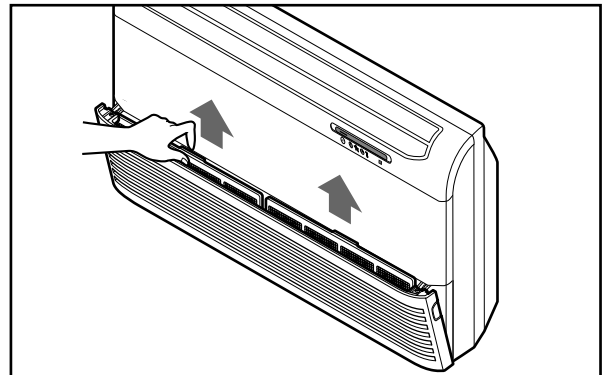

2. Check the drainage.

- Spray one or two glasses of water upon the evaporator.
- Ensure that water flows drain hose of indoor unit without any leakage.

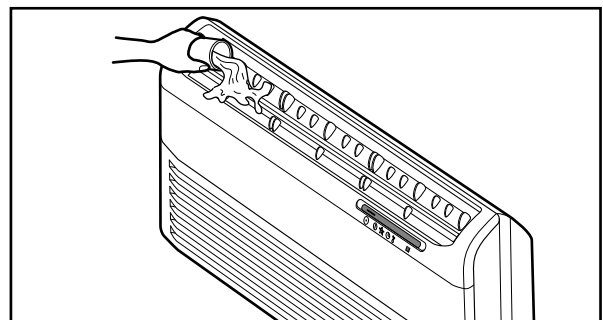

## 6. Connecting Cables between Indoor Unit and Outdoor Unit

### 1) Connecting cables to the Indoor Unit

- 1) Remove the Air guide - L by loosening 2 screws after removing the Inlet grille from the Indoor unit.
- 2) Connect the wires to the terminals on the control board individually according to the outdoor unit connection.
  - Ensure that the color of the wires of outdoor unit and the terminal No. are the same as those of indoor unit respectively

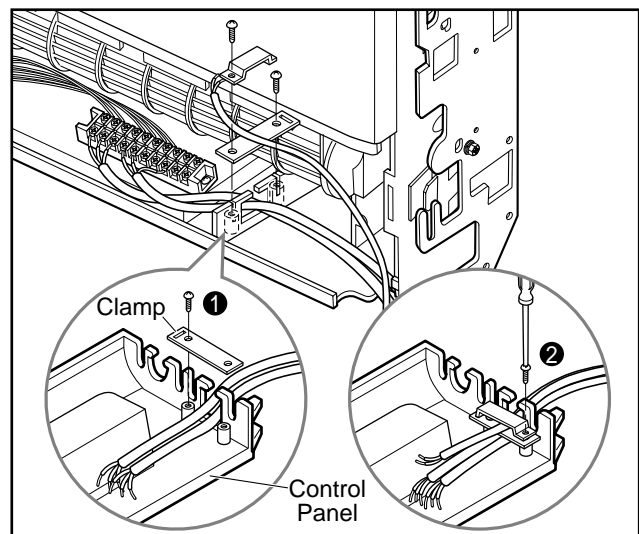
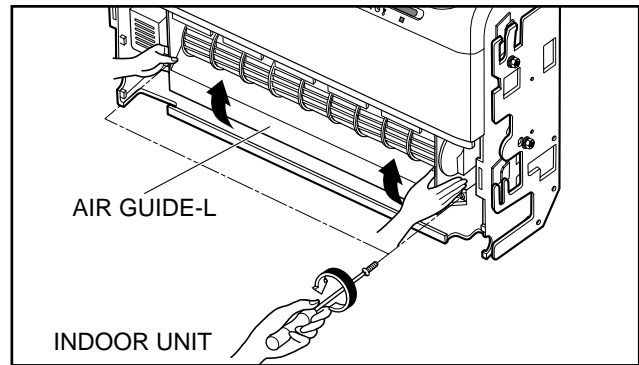

### 2) Clamping of cables

- 1) Arrange 2 power cables on the control panel.
- 2) First, fasten the steel clamp with a screw to the inner boss of control panel.
- 3) For the cooling model, fix the other side of the clamp with a screw strongly.  
For the heat pump model, put the 0.75mm<sup>2</sup> cable(thinner cable) on the clamp and tighten it with a plastic clamp to the other boss of the control panel.
- 4) In Australia, the length of power supply cord measured from the entry of the power supply cord to the middle of live pin on the power plug should be over 1.8m.

<b>CAUTION</b>		
<p><b>The power cord</b> connected to the indoor unit should be complied with the following specifications (Type H05VV-F(Indoor) approved by HAR or SAA).</p> <p>NORMAL CROSS-SECTIONAL AREA</p> <ul style="list-style-type: none"> <li>• 2.5mm<sup>2</sup>(24K)</li> <li>• 2.0mm<sup>2</sup>(18K;for the Middle East)</li> <li>• 1.5mm<sup>2</sup>(18K;for the other area)</li> </ul>	<p><b>The power connecting cable</b> connected between the indoor and outdoor unit should be complied with the following specifications (Type H07RN-F approved by HAR or SAA).</p> <p>NORMAL CROSS-SECTIONAL AREA</p> <ul style="list-style-type: none"> <li>• 2.5mm<sup>2</sup>(24K)</li> <li>• 2.0mm<sup>2</sup>(18K;for the Middle East)</li> <li>• 1.5mm<sup>2</sup>(18K;for the other area)</li> </ul>	<p><b>The connecting cable</b> connected between the indoor and outdoor unit should be complied with the following specifications (Type H07RN-F approved by HAR or SAA).</p> <p>NORMAL CROSS-SECTIONAL AREA</p> <p>0.75mm<sup>2</sup></p>

### 3) Connecting the cable to Outdoor Unit

1. Remove the Cover control from the unit by loosening a screw.  
Connect the wires to the terminals on the control board individually as following.
2. Secure the cable onto the control board with the holder (clamper).
3. Refix the cover control to the original position with the screw.
4. Use a recognized circuit breaker 20A(18K, 24K) between the power source and the unit. A disconnection device to adequately disconnect all supply lines must be fitted.

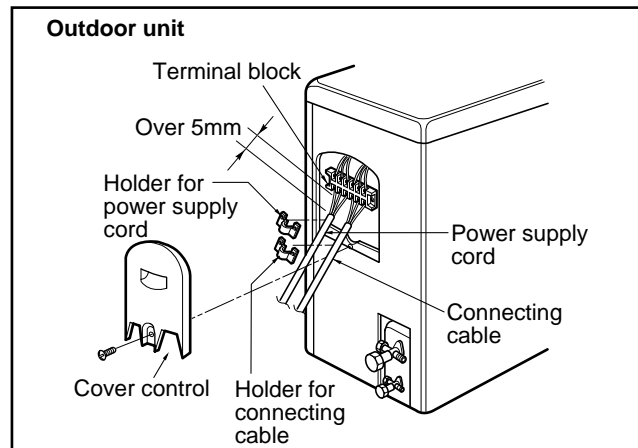

#### CAUTION

After the confirmation of the above conditions, prepare the wiring as follows:

- 1) **Never fail to have an individual power specialized for the air conditioner. As for the method of wiring, be guided by the circuit diagram pasted on the inside of control box cover.**
- 2) **Provide a circuit breaker switch between power source and the unit.**
- 3) **The screw which fasten the wiring in the casing of electrical fittings are liable to come loose from vibrations to which the unit is subjected during the course of transportation. Check them and make sure that they are all tightly fastened. (If they are loose, it could give rise to burn-out of the wires.)**
- 4) **Specification of power source**
- 5) **Confirm that electrical capacity is sufficient.**
- 6) **Be sure that the starting voltage is maintained at more than 90 percent of the rated voltage marked on the name plate.**
- 7) **Confirm that the cable thickness is as specified in the power sources specification. (Particularly note the relation between cable length and thickness.)**
- 8) **Never fail to equip a leakage breaker where it is wet or moist.**
- 9) **The following troubles would be caused by voltage drop-down.**
  - Vibration of a magnetic switch, damage on the contact point there of, fuse breaking, disturbance to the normal function of a overload protection device.
  - Proper starting power is not given to the compressor.
- 10) **The means for disconnection from a power supply shall be incorporated in the fixed wiring and have an air gap contact separation of at least 3mm in each active(phase) conductors.**

#### 4) Form the pipings

**1. Wrap the connecting portion of indoor unit with the Insulation material and secure it with two Plastic Bands. (for the right pipings)**

- If you want to connect an additional drain hose, the end of the drain-outlet should keep distance from the ground. (Do not dip it into water, and fix it on the wall to avoid swinging in the wind.)

In case of the Outdoor unit being installed below position of the Indoor unit.

**2. Tape the Pipings, drain hose and Connecting Cable from bottom to top.**

**3. Form the pipings gathered by taping along the exterior wall and fix it onto the wall by saddle or equivalent.**

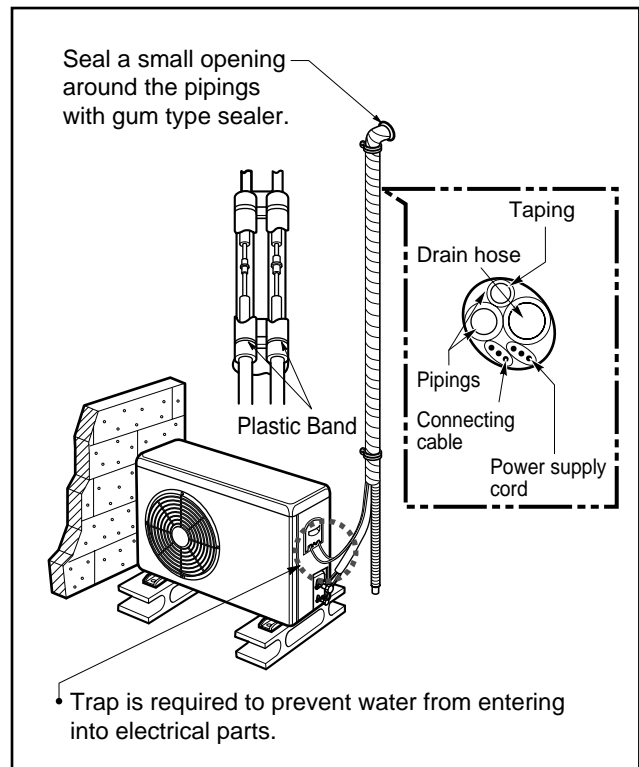

In case of the Outdoor Unit being installed above position of the Indoor Unit.

**2. Tape the Pipings and Connecting cable from bottom to top.**

**3. Form the pipings gathered by taping along the exterior wall, and make the trap prevent water from entering into the room.**

**4. Fix the pipings onto the wall by saddle or equivalent.**

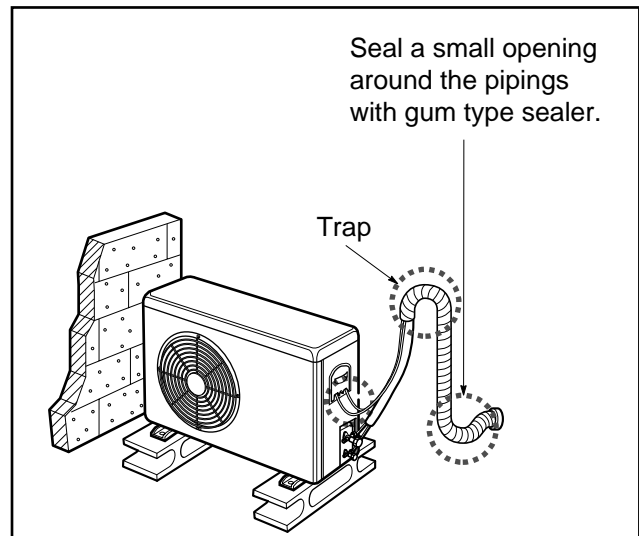

## 7. Air Purging of the Pipes and Indoor Unit

The air which contains moisture remaining in the refrigeration cycle may cause a malfunction on the compressor.

1. Confirm that both the liquid side valve and the gas side valve are set to the closed position.
2. After connecting the piping, check the joints for gas leakage with gas leak detector.
3. Remove the service port nut, and connect the gauge manifold and the vacuum pump to the service port by the charge hose.
4. Vacuum the indoor unit and the connecting pipes until the pressure in them lowers to below -76cmHg.
5. Remove the valve stem nuts, and fully open the stems of the 2-way and 3-way valves with a hexagon wrench.
6. Tighten the valve stem nuts of the 2-way valve and 3-way valve.
7. Disconnect the charge hose and fit the nut to the service port.  
(Tightening torque: 1.8kg.m)

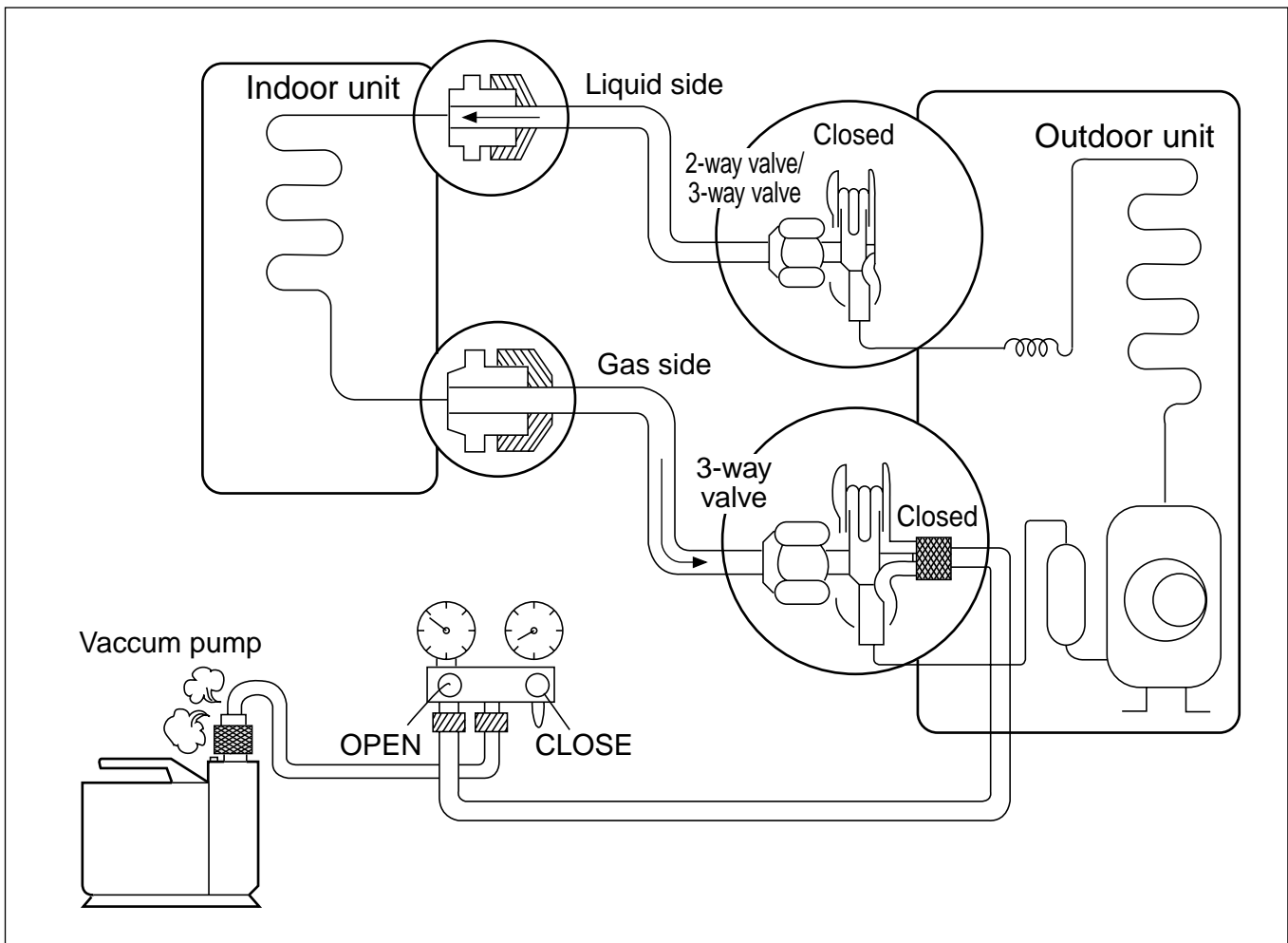

## 8. Test running

### 1) Connection of power supply

#### 1. Connect the power supply cord to the independent power supply.

- Circuit breaker is required.

#### 2. Prepare the remote control.

- Insert two batteries provided.  
Remove the battery cover from the remote controller.
- Slide the cover according to the arrow direction.  
Insert the two batteries.  
(Two "R03" or "AAA" dry-cell batteries or equivalent.)
- Be sure that the (+) and (-) directions are correct.
- Be sure that both batteries are new.  
Re-attach the cover.
- Slide it back into position.

#### 3. Operate the unit for fifteen minutes or more.

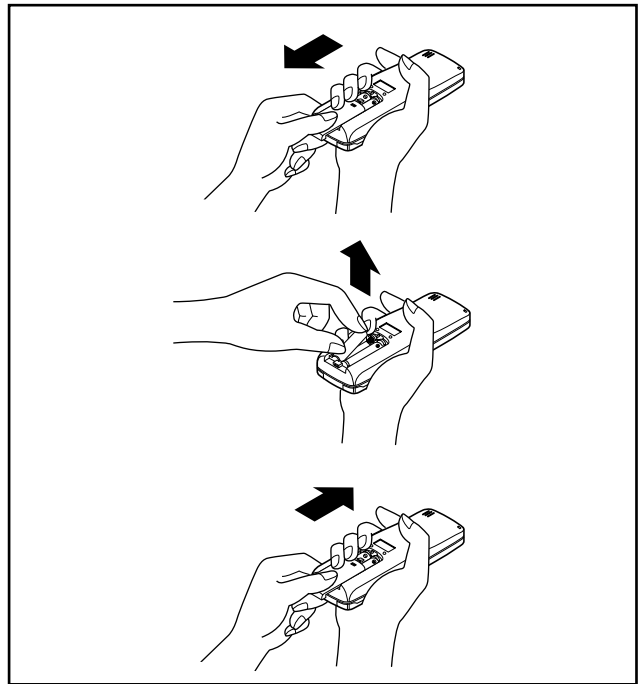

### 2) Evaluation of the performance

1. Measure the temperature of the intake and discharge air.
2. Ensure the difference between the intake temperature and the discharge one is more than 8°C (Cooling) or reversely (Heating).

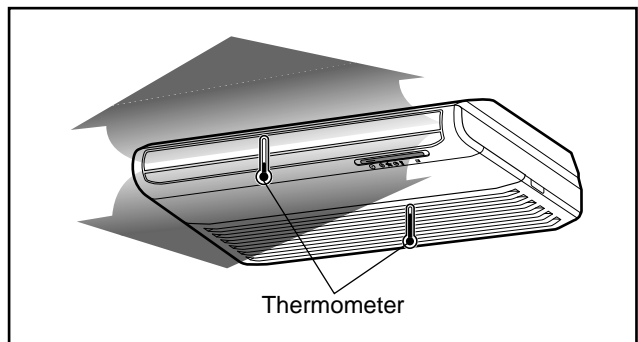

### 3) Selection of the slide switch according to installation method

1. In case the indoor unit is installed on the floor, please change the side switch which is on the Main PCB Assembly to the 'BOTTOM' state.
2. In case the indoor unit is installed under the ceiling, please change the slide switch which is on the Main PCB Assembly to the 'CEILING' state.

**The initial state of the slide switch is set for the bottom installation.**

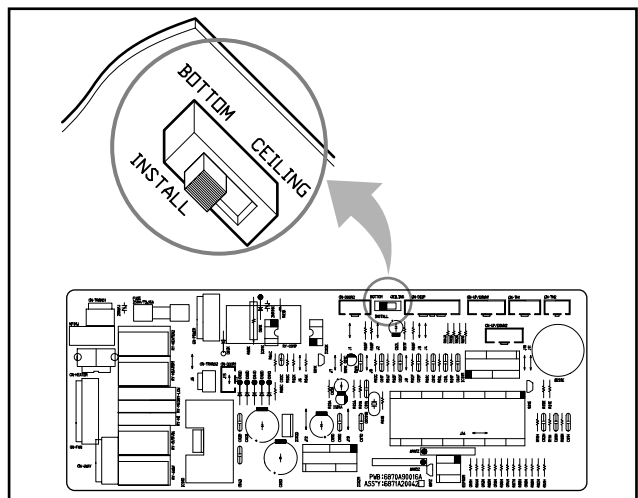

# Operation

## (1) Name and Function-Remote controller

### 1) Cooling Model

#### Remote Controller

#### Signal transmitter.

Transmits the signals to the room air conditioner.

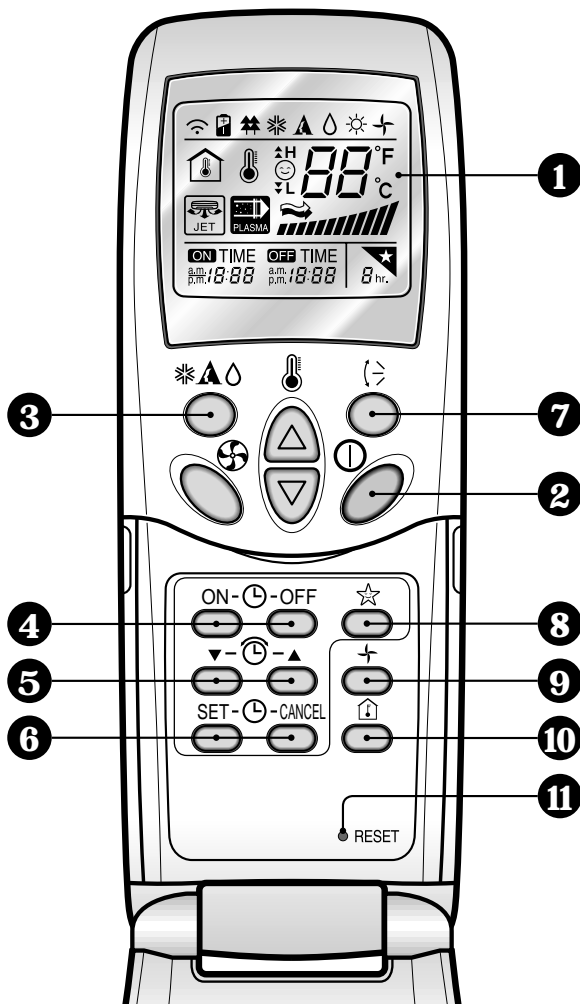

- 1 OPERATION DISPLAY**  
Displays the operation conditions.
- 2 START/STOP BUTTON**  
Operation starts when this button is pressed and stops when the button is pressed again.
- 3 OPERATION MODE SELECTION BUTTON**  
Used to select the operation mode.
- 4 ON/OFF TIMER BUTTONS**  
Used to set the time of starting and stopping operation.
- 5 TIME SETTING BUTTONS**  
Used to adjust the time.
- 6 TIMER SET/CANCEL BUTTONS**  
Used to set the timer when the desired time is obtained and to cancel the Timer operation.
- 7 AIR FLOW DIRECTION START/STOP BUTTON**  
Used to stop or start louver movement and set the desired up/down airflow direction.
- 8 SLEEP MODE AUTO BUTTON**  
Used to set Sleep Mode Auto operation.
- 9 AIR CIRCULATION BUTTON**  
Used to circulate the room air without cooling or heating (turns indoor fan on/off).
- 10 ROOM TEMPERATURE CHECKING BUTTON**  
Used to check the room temperature.
- 11 RESET BUTTON**  
Used prior to resetting time or after replacing batteries.

## 2) Heat Pump Model

### Remote Controller

#### Signal transmitter.

Transmits the signals to the room air conditioner.

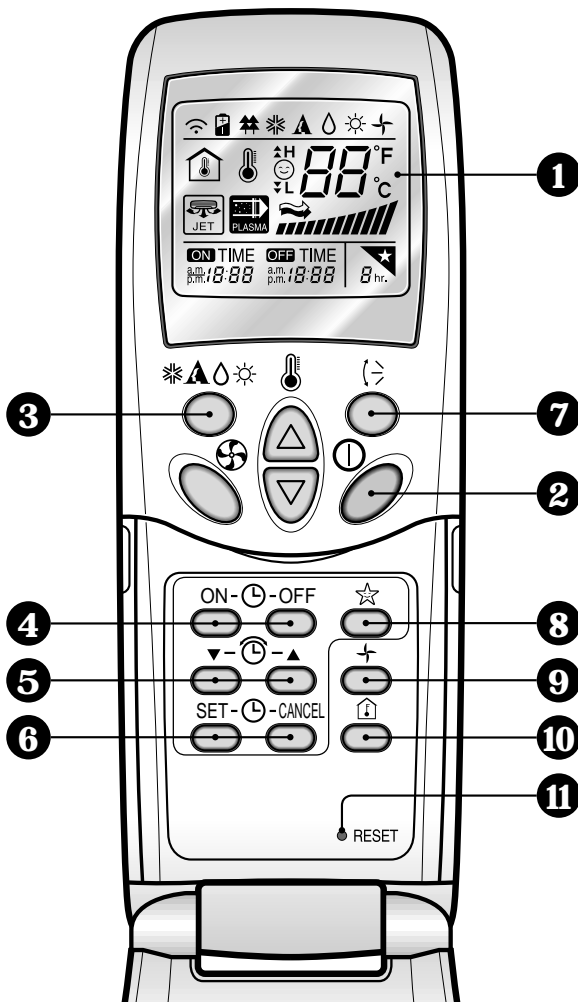

- 1 OPERATION DISPLAY**  
Displays the operation conditions.
- 2 START/STOP BUTTON**  
Operation starts when this button is pressed and stops when the button is pressed again.
- 3 OPERATION MODE SELECTION BUTTON**  
Used to select the operation mode.
- 4 ON/OFF TIMER BUTTONS**  
Used to set the time of starting and stopping operation.
- 5 TIME SETTING BUTTONS**  
Used to adjust the time.
- 6 TIMER SET/CANCEL BUTTONS**  
Used to set the timer when the desired time is obtained and to cancel the Timer operation.
- 7 AIR FLOW DIRECTION START/STOP BUTTON**  
Used to stop or start louver movement and set the desired up/down airflow direction.
- 8 SLEEP MODE AUTO BUTTON**  
Used to set Sleep Mode Auto operation.
- 9 AIR CIRCULATION BUTTON**  
Used to circulate the room air without cooling or heating (turns indoor fan on/off).
- 10 ROOM TEMPERATURE CHECKING BUTTON**  
Used to check the room temperature.
- 11 RESET BUTTON**  
Used prior to resetting time or after replacing batteries.



# Disassembly of the parts (Indoor unit)

## Warning :

Disconnect the unit from power supply before making any checks.

Be sure the power switch is set to "OFF".

### 1. Remove the air filter.

- Pull the inlet grille slightly toward you.
- Pull out the air filter. (2 pieces)

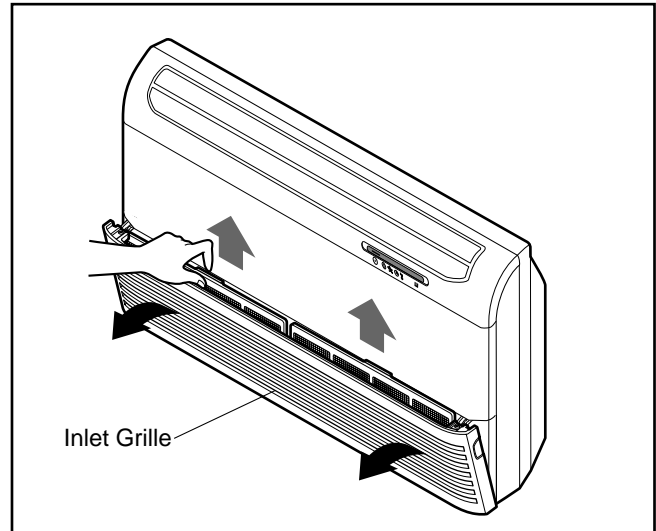

### 2. Remove the grille from chassis

- Remove the screws securing the side plate and push to the bottom-side.
- Unhook the hanger from the hanger screw at the left and the right side.
- Pick out the inlet grille.

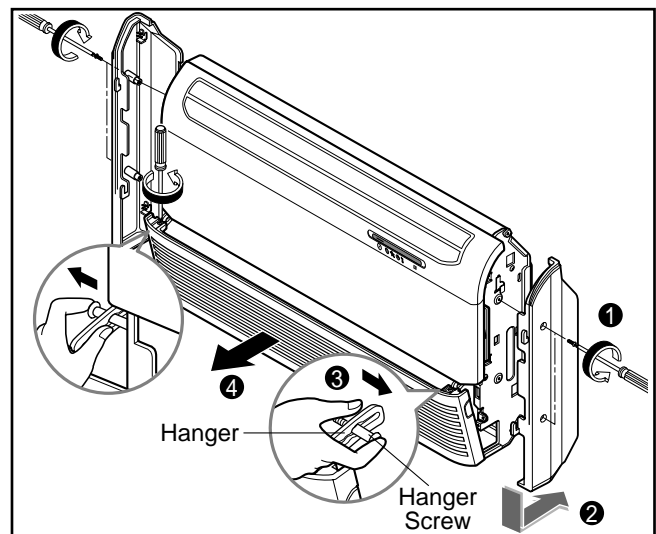

### 3. Remove the lower air guide

- Remove a screw of both side fixing "barrier air-guide".
- Remove the screws of both sides of the lower air-guide.
- Remove the lower air-guide toward "arrow mark" by turning upwards as shown in figure.

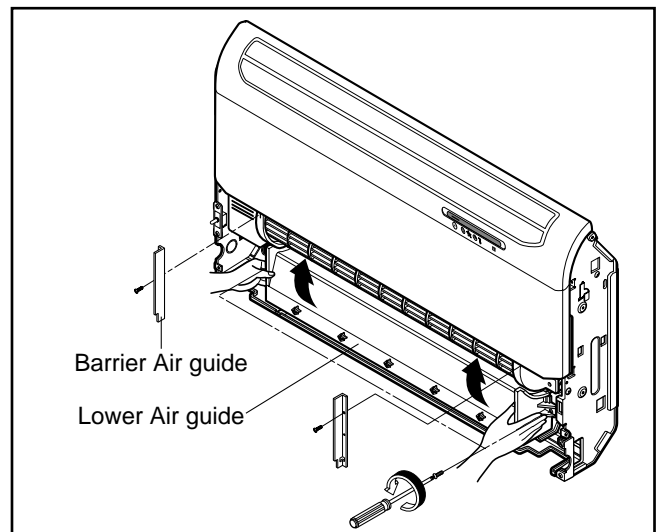

#### 4. Remove air guide upper, crossflow fan and motor.

- Remove the screws of both sides and center securing the upper air-guide.
- Remove 2 screws fastening the bracket of door switch.

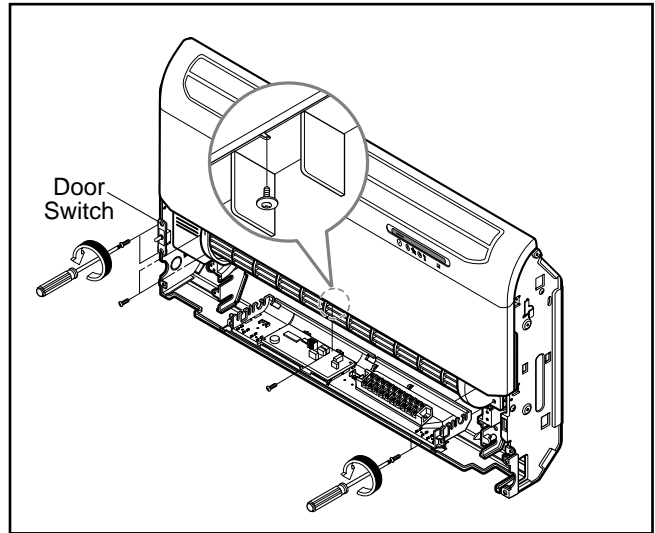

- Remove a bearing assembly by removing a screw and the bearing cover.
- Remove 4 screws securing the motor cover.
- Loosen the screw securing the crossflow fan to the fan motor shaft. (do not remove)
- Remove the crossflow fan by sliding it out from the shaft of fan motor.

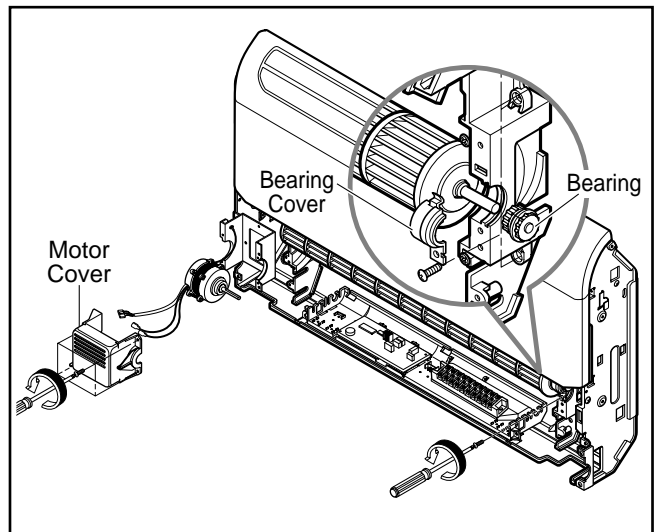

#### 5. Remove the control box Assembly.

- Disconnect the step motor connector, fan motor connector, display PCB connector, thermistor connector and door switch connector from the main PCB.
- If necessary, disconnect power supply cord and connecting cable from the terminal block and remove the cord clamp screw.
- Remove 2 screws securing the control box and pick out the control box carefully.

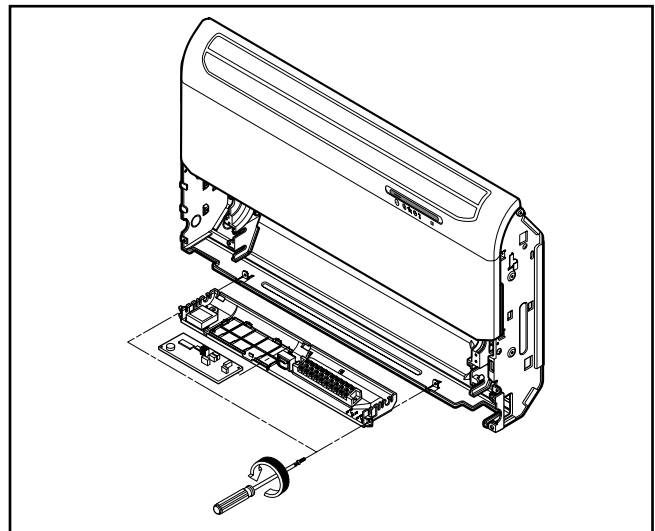

### 6. Remove the front panel.

- Remove the screws of both sides fixing the front panel.
- Push the upper side of front panel strongly to pull out the front panel from the inner hook of diffuser frame.
- Pull down the front panel carefully not so as to harm the display PCB wires and thermistor wires.

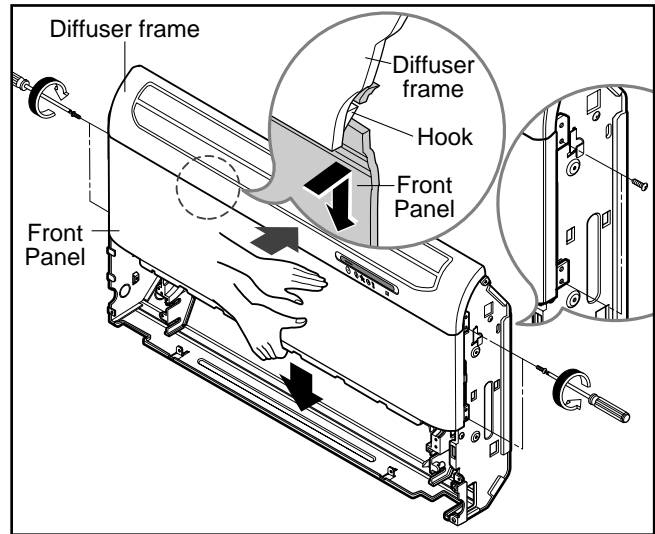

### 7. Remove the diffuser assembly.

- Remove the screws of both side of diffuser assembly. (4 pieces)
- Push the upper side of cabinet strongly to pull out the inner hook of diffuser frame from the cabinet hole.
- Take up the diffuser frame carefully not so as to harm the display PCB wires and the step motor wires.

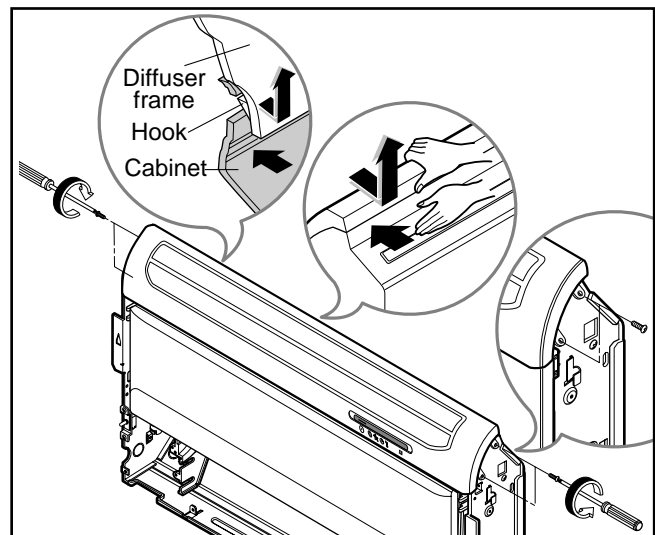

### 8. Remove display PCB assembly.

- Remove the screws at the both side of display cover.
- If necessary, disconnect the display PCB connector from PCB assembly.
- Remove 2 screws of PCB assembly.

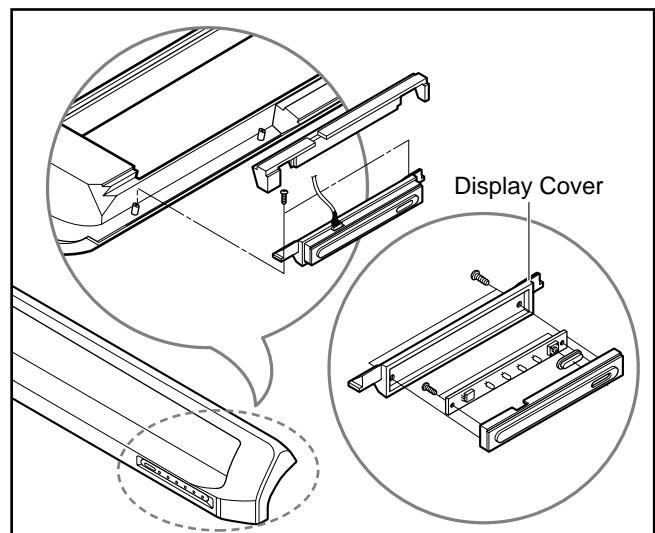

**9. Remove the vane-upper, vane-lower and step motor.**

- Remove 2 screws securing the step motor assembly and pull it out from the vanes carefully.
- Unhook the vanes from the vane supporter and remove the upper vane and lower vane by pulling the center of vanes with care.

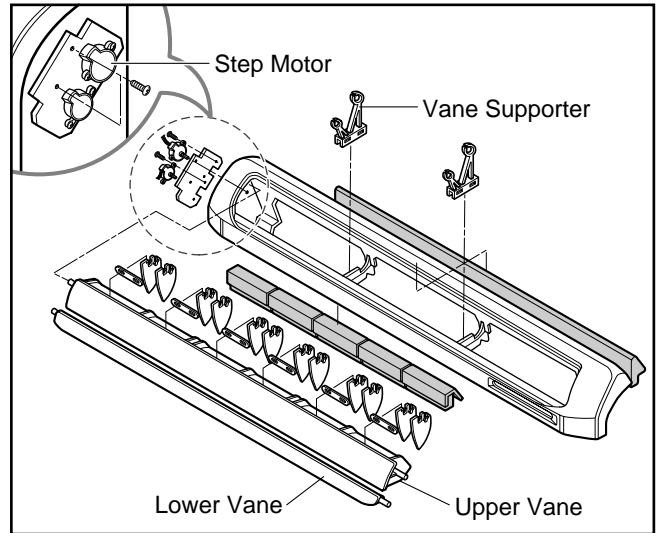

**10. Remove the drain pan assembly.**

- Remove the both side of screws. (4 pieces)
- Pull out the drain pan assembly.
- Be careful not to harm to the EPS packing of drain pan and the tubings of evaporator.

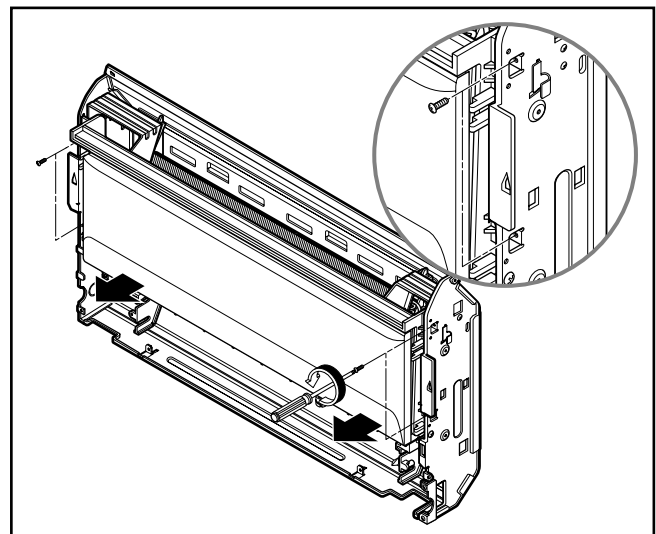

**11. Remove the evaporator.**

- Remove the screws of both sides securing the EVA barrier-R/L on the side cabinet.
- Remove the screws which fasten the barrier on the evaporator and take out the barrier assembly.
- Remove the evaporator assembly by sliding toward arrow mark. (As shown in figure)

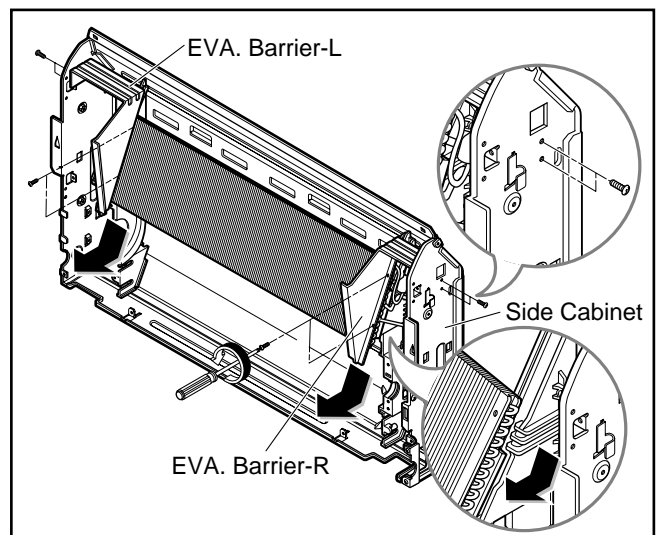

# 2-way, 3-way Valve

		2-way Valve (Liquid Side)	3-way Valve (Gas Side or Liquid Side)	
Works		Shaft position	Shaft position	Service port
Shipping		Closed (with valve cap)	Closed (with valve cap)	Closed (with cap)
1.	Air purging (Installation)	Open (counter-clockwise)	Closed (clockwise)	Open (push-pin or with vacuum pump)
Operation		Open (with valve cap)	Open (with valve cap)	Closed (with cap)
2.	Pumping down (Transferring)	Closed (clockwise)	Open (counter-clockwise)	Open (connected manifold gauge)
3.	Evacuation (Servicing)	Open	Open	Open (with Vacuum pump)
4.	Gas charging (Servicing)	Open	Open	Open (with charging cylinder)
5.	Pressure check (Servicing)	Open	Open	"
6.	Gas releasing (Servicing)	Open	Open	"

# 1. Pumping down

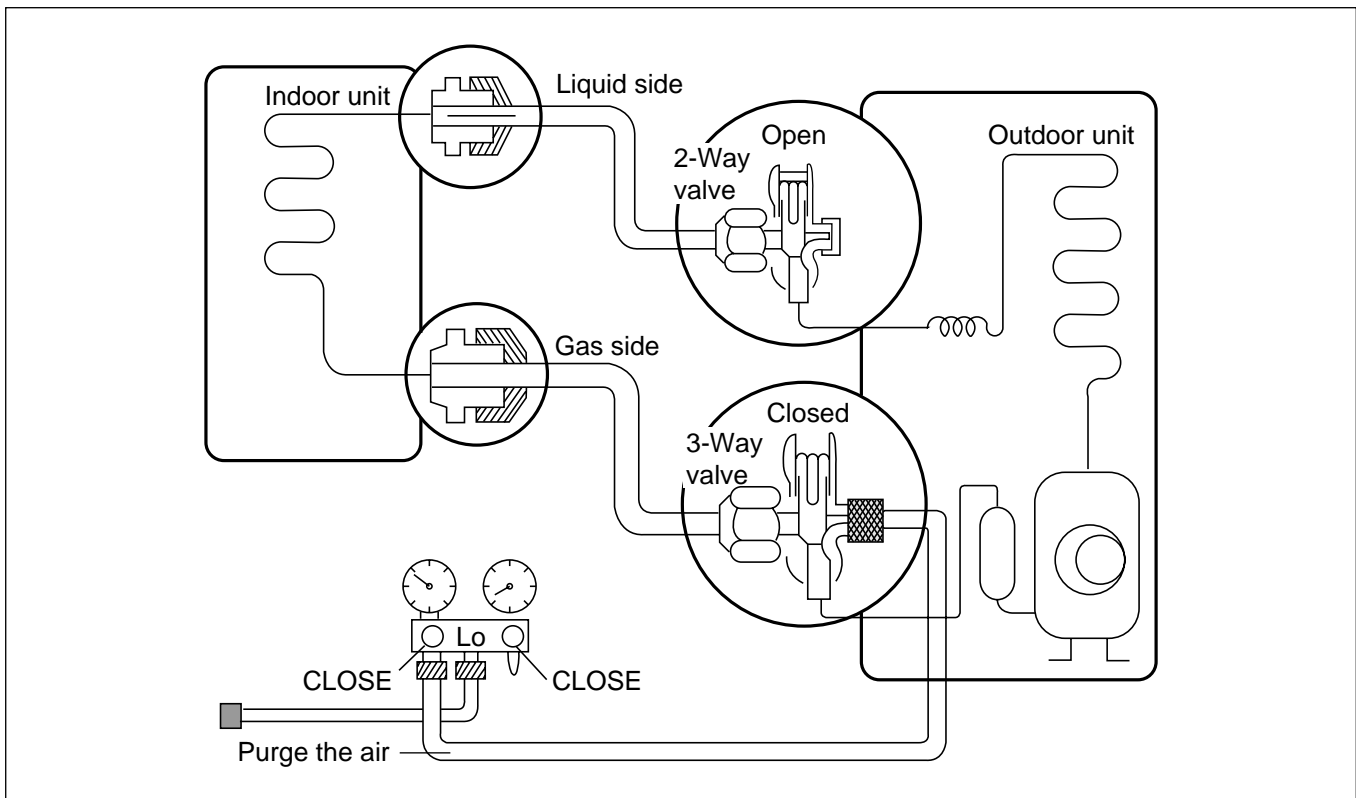

## • Procedure

- (1) Confirm that both liquid side and gas side valves are set to the open position.**
  - Remove the valve stem caps and confirm that the valve stems are in the raised position.
  - Be sure to use a hexagonal wrench to operate the valve stems.
- (2) Operate the unit for 10 to 15 minutes.**
- (3) Stop operation and wait for 3 minutes, then connect the charge set to the service port of the 3-way valve.**
  - Connect the charge hose to the service port.
- (4) Air purging of the charge hose.**
  - Open the low-pressure valve on the charge set slightly to air purge from the charge hose.
- (5) Set the liquid side valve to the closed position.**
- (6) Operate the air conditioner in cooling mode and stop it when the gauge indicates 1kg/cm<sup>2</sup>g.**
- (7) Immediately set the 3-way valve to the closed position.**
  - Do this quickly so that the gauge ends up indicating 3 to 5kg/cm<sup>2</sup>g.
- (8) Disconnect the charge set, and mount the 2-way and 3-way valve's stem nuts and the service port nut.**
  - Use torque wrench to tighten the service port nut to a torque of 1.8 kg.m.
  - Be sure to check for gas leakage.

## 1) Re-air purging (Re-installation)

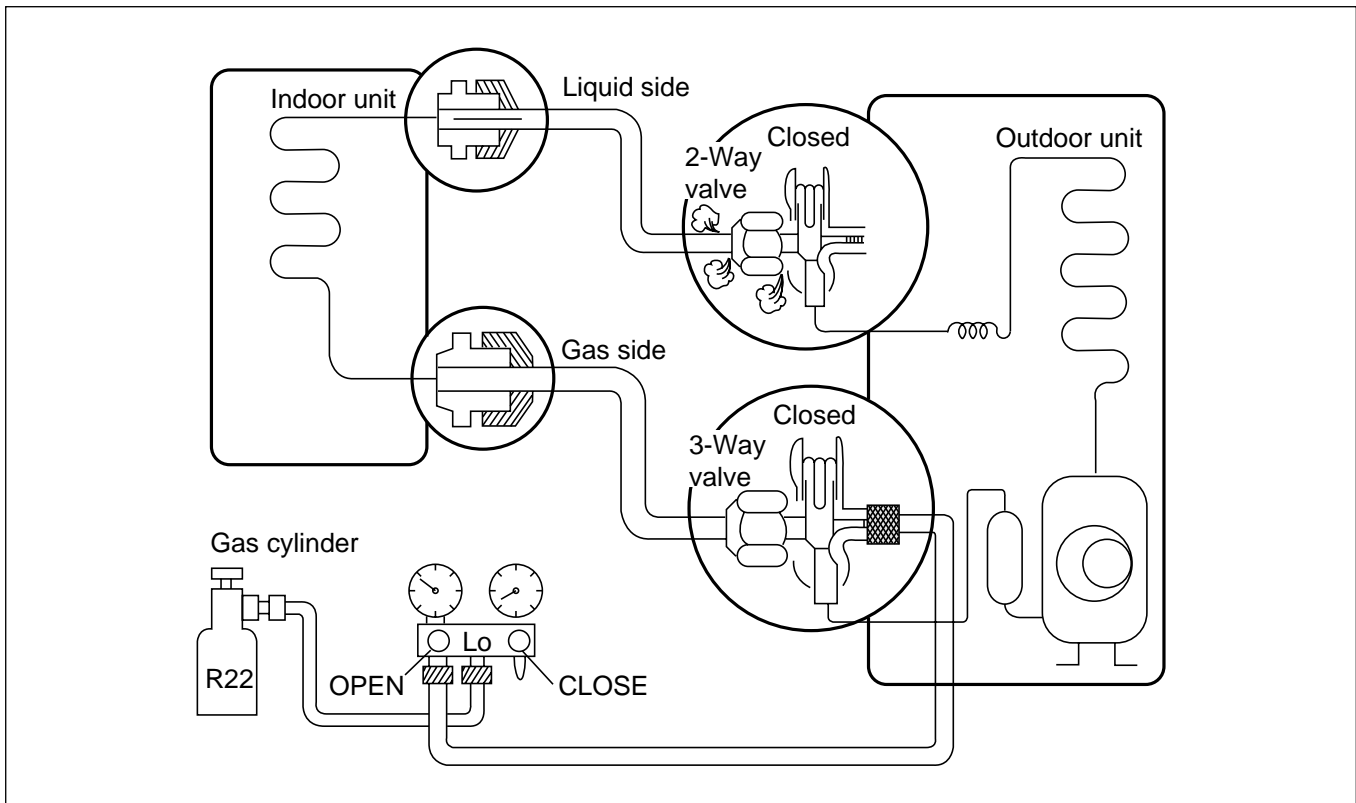

### • Procedure

- (1) **Confirm that both the liquid side valve and the gas side valve are set to the closed position.**
  - (2) **Connect the charge set and a gas cylinder to the service port of the 3-way valve.**
    - Leave the valve on the gas cylinder closed.
  - (3) **Air purging.**
    - Open the valves on the gas cylinder and the charge set. Purge the air by loosening the flare nut on the liquid side valve approximately 45° for 3 seconds then closing it for 1 minute; repeat 3 times.
    - After purging the air, use a torque wrench to tighten the flare nut on liquid side valve.
  - (4) **Check for gas leakage.**
    - Check the flare connections for gas leakage.
  - (5) **Discharge the refrigerant.**
    - Close the valve on the gas cylinder and discharge the refrigerant until the gauge indicates 3 to 5 kg/cm<sup>2</sup>g.
  - (6) **Disconnect the charge set and the gas cylinder, and set the 2-way and 3-way valves to the open position.**
    - Be sure to use a hexagonal wrench to operate the valve stems.
  - (7) **Mount the valve stem nuts and the service port nut.**
    - Use torque wrench to tighten the service port nut to a torque of 1.8 kg.m.
    - Be sure to check for gas leakage.
- \* **CAUTION:**  
**Do not leak the gas in the air during Air Purging.**

## 2) Balance refrigerant of the 2-way, 3-way valves (Gas leakage)

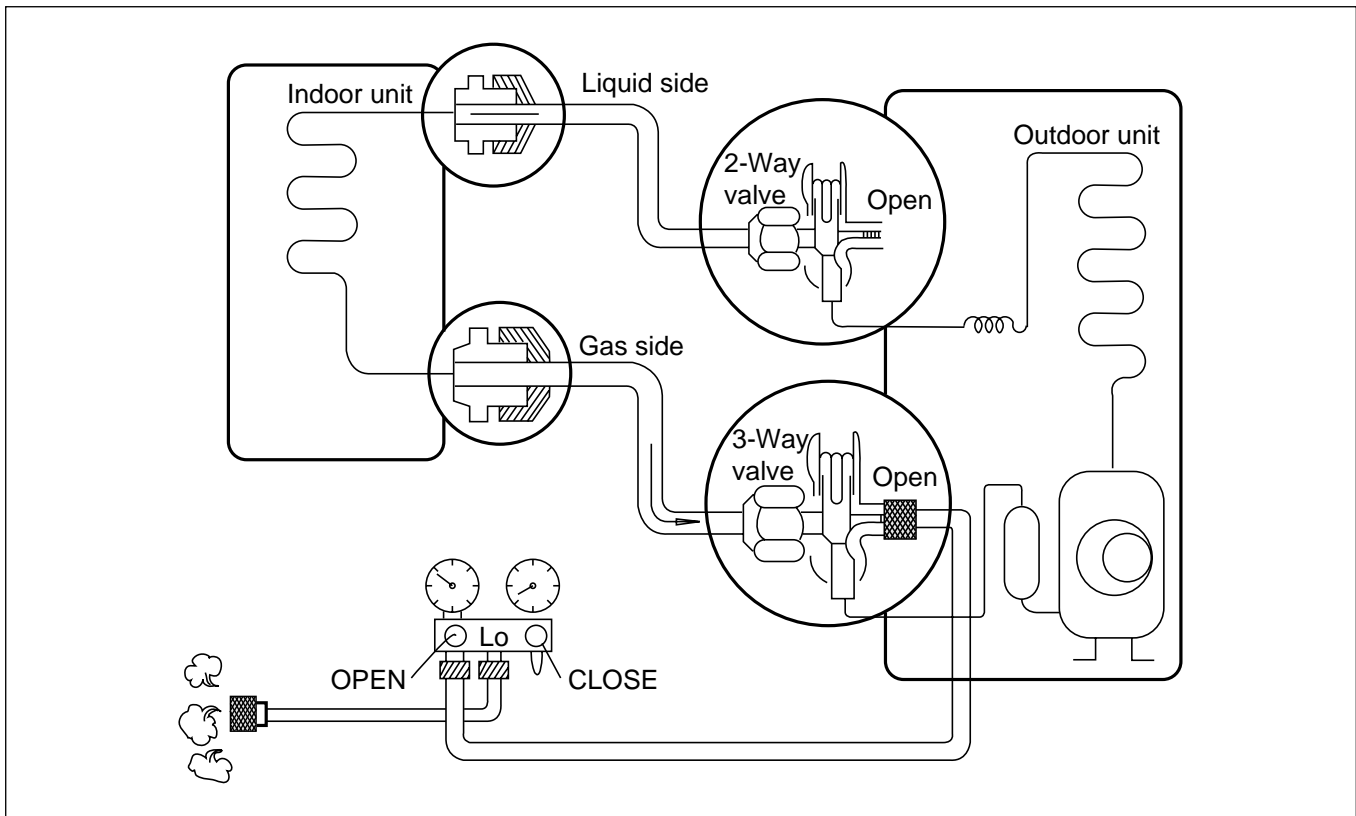

### • Procedure

- (1) Confirm that both the liquid side and gas side valves are set to the back seat.
- (2) Connect the charge set to the 3-way valve's port.
  - Leave the valve on the charge set closed.
  - Connect the charge hose to the service port.
- (3) Open the valve (Lo side) on the charge set and discharge the refrigerant until the gauge indicates **0 kg/cm<sup>2</sup>G**.
  - If there is no air in the refrigerant cycle (the pressure when the air conditioner is not running is higher than 1 kg/cm<sup>2</sup>G), discharge the refrigerant until the gauge indicates 0.5 to 1 kg/cm<sup>2</sup>G. If this is the case, it will not be necessary to apply a evacuation.
  - Discharge the refrigerant gradually; if it is discharged too suddenly, the refrigeration oil will also be discharged.



## 2. Evacuation

(All amount of refrigerant leaked)

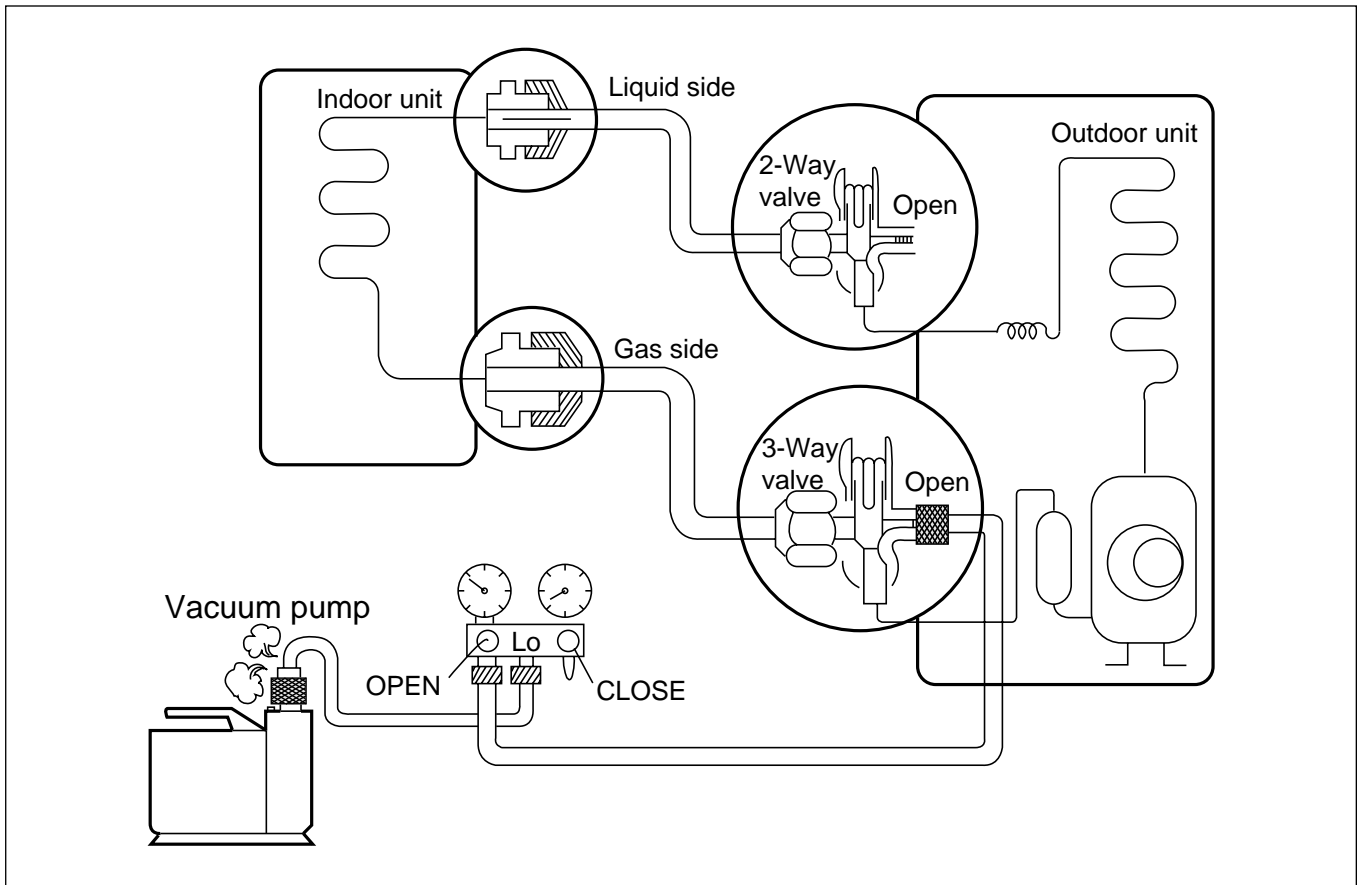

### • Procedure

- (1) Connect the vacuum pump to the center hose of charge set center hose
- (2) Evacuation for approximately one hour.
  - Confirm that the gauge needle has moved toward -76 cmHg (vacuum of 4 mmHg or less).
- (3) Close the valve (Lo side) on the charge set, turn off the vacuum pump, and confirm that the gauge needle does not move (approximately 5 minutes after turning off the vacuum pump).
- (4) Disconnect the charge hose from the vacuum pump.
  - Vacuum pump oil.  
If the vacuum pump oil becomes dirty or depleted, replenish as needed.

### 3. Gas Charging

(After Evacuation)

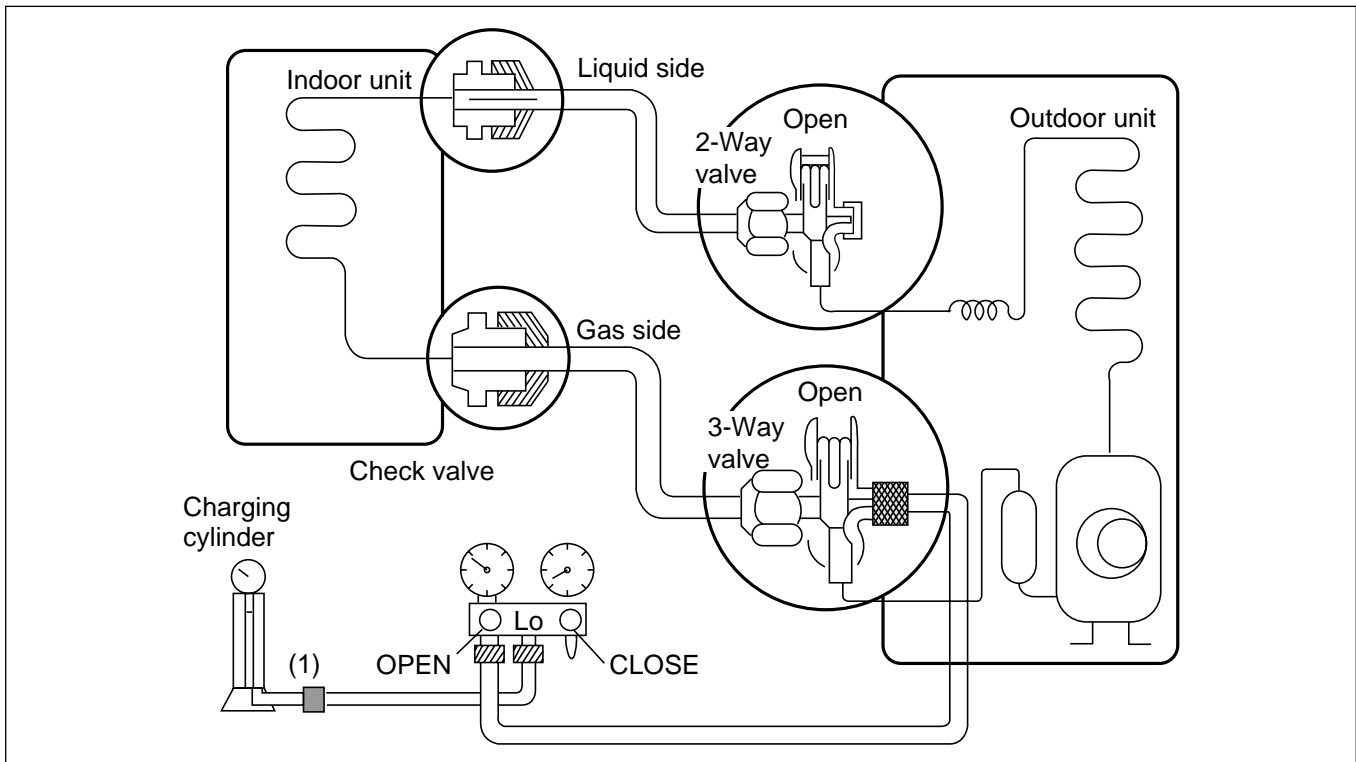

#### • Procedure

##### (1) Connect the charge hose to the charging cylinder.

- Connect the charge hose which you disconnected from the vacuum pump to the valve at the bottom of the cylinder.
- If you are using a gas cylinder, also use a scale and reverse the cylinder so that the system can be charged with liquid.

##### (2) Purge the air from the charge hose.

- Open the valve at the bottom of the cylinder and press the check valve on the charge set to purge the air. (Be careful of the liquid refrigerant). The procedure is the same if using a gas cylinder.

##### (3) Open the valve (Lo side on the charge set and charge the system with liquid refrigerant.

- If the system can not be charged with the specified amount of refrigerant, it can be charged with a little at a time (approximately 150g each time) while operating the air conditioner in the cooling cycle; however, one time is not sufficient, wait approximately 1 minute and then repeat the procedure (pumping down-pin).

This is different from previous procedures. Because you are charging with liquid refrigerant from the gas side, absolutely do not attempt to charge with larger amounts of liquid refrigerant while operating the air conditioner.

##### (4) Immediately disconnect the charge hose from the 3-way valve's service port.

- Stopping partway will allow the gas to be discharged.
- If the system has been charged with liquid refrigerant while operating the air conditioner turn off the air conditioner before disconnecting the hose.

##### (5) Mount the valve stem nuts and the service port nut.

- Use torque wrench to tighten the service port nut to a torque of 1.8 kg.m.
- Be sure to check for gas leakage.

# Cycle Troubleshooting Guide

## Trouble analysis

1. Check temperature difference between intake and discharge air and operating current.

	Temp. difference : approx. 0°C Current : less than 80% of rated current	All amount of refrigerant leaked out Check refrigeration cycle
Temp. Difference	Temp. difference : approx. 8°C Current : less than 80% of rated current	Refrigerant leakage Clog of refrigeration cycle Defective compressor
Operating Current	Temp. difference : less than 8°C Current : over the rated current	Excessive amount of refrigerant
	Temp. difference : over 8°C	Normal

**Notice :**

Temperature difference between intake and discharge air depends on room air humidity. When the room air humidity is relatively higher, temperature difference is smaller. When the room air humidity is relatively lower temperature difference is larger.

2. Check temperature and pressure of refrigeration cycle.

Suction pressure (Compared with the normal value)	Temperature (Compared with the normal value)	Cause of Trouble	Description
Higher	High	Defective compressor Defective 4-way reverse valve	Current is low
	Normal	Excessive amount of refrigerant	High pressure does not quickly rise at the beginning of operation
Lower	Higher	Insufficient amount of refrigerant (Leakage) Clogging	Current is low Current is low

**Notice :**

1. The suction pressure is usually 4.5~6.0 kg/cm<sup>2</sup>G at normal condition.
2. The temperature can be measured by attaching the thermometer to the low pressure tubing and wrap it with putty.

# Electronic Parts Troubleshooting Guide

**Possible Trouble 1** : The unit does not operate.

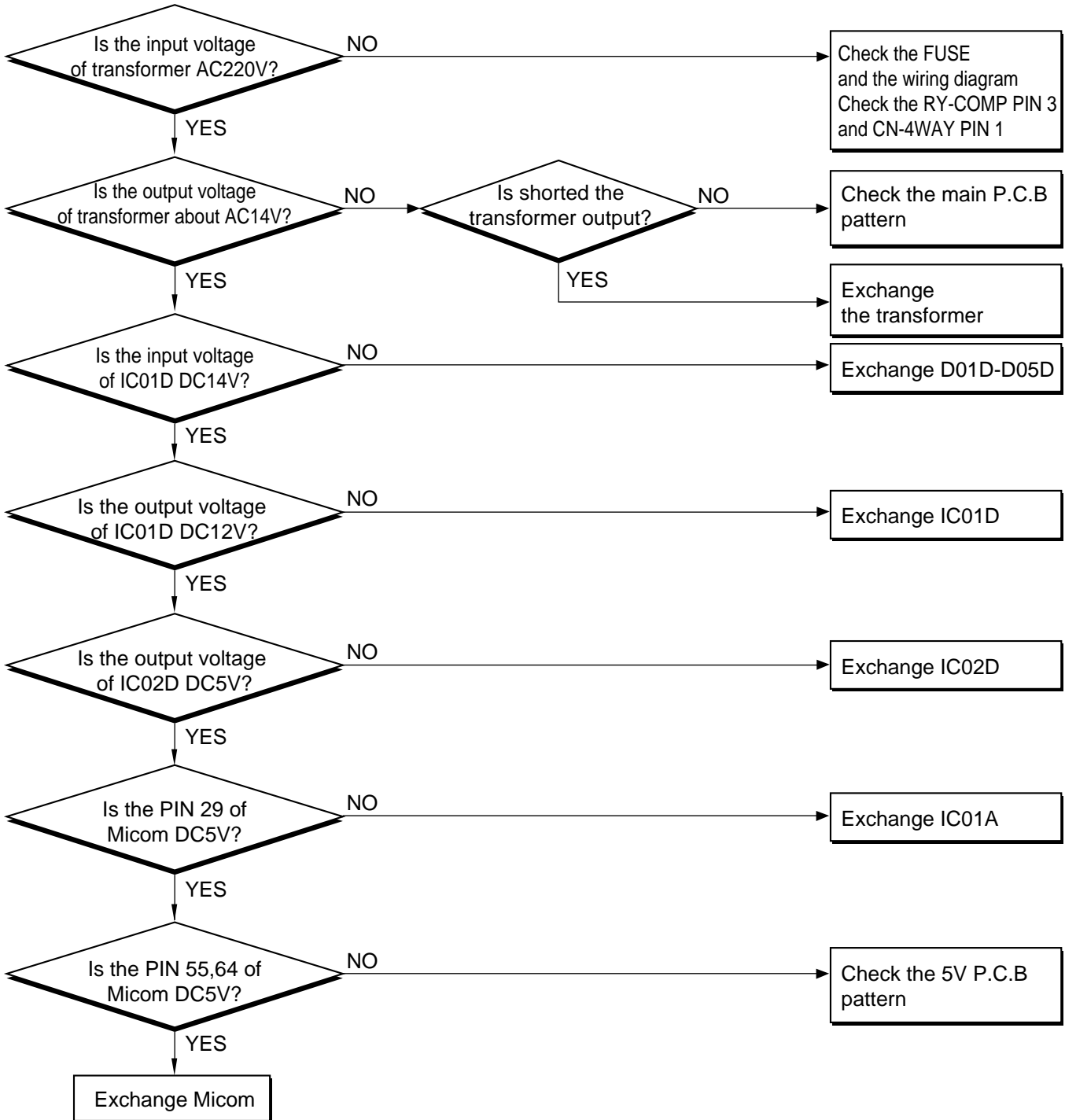

**Possible Trouble 2**

: The indoor fan does not operate.

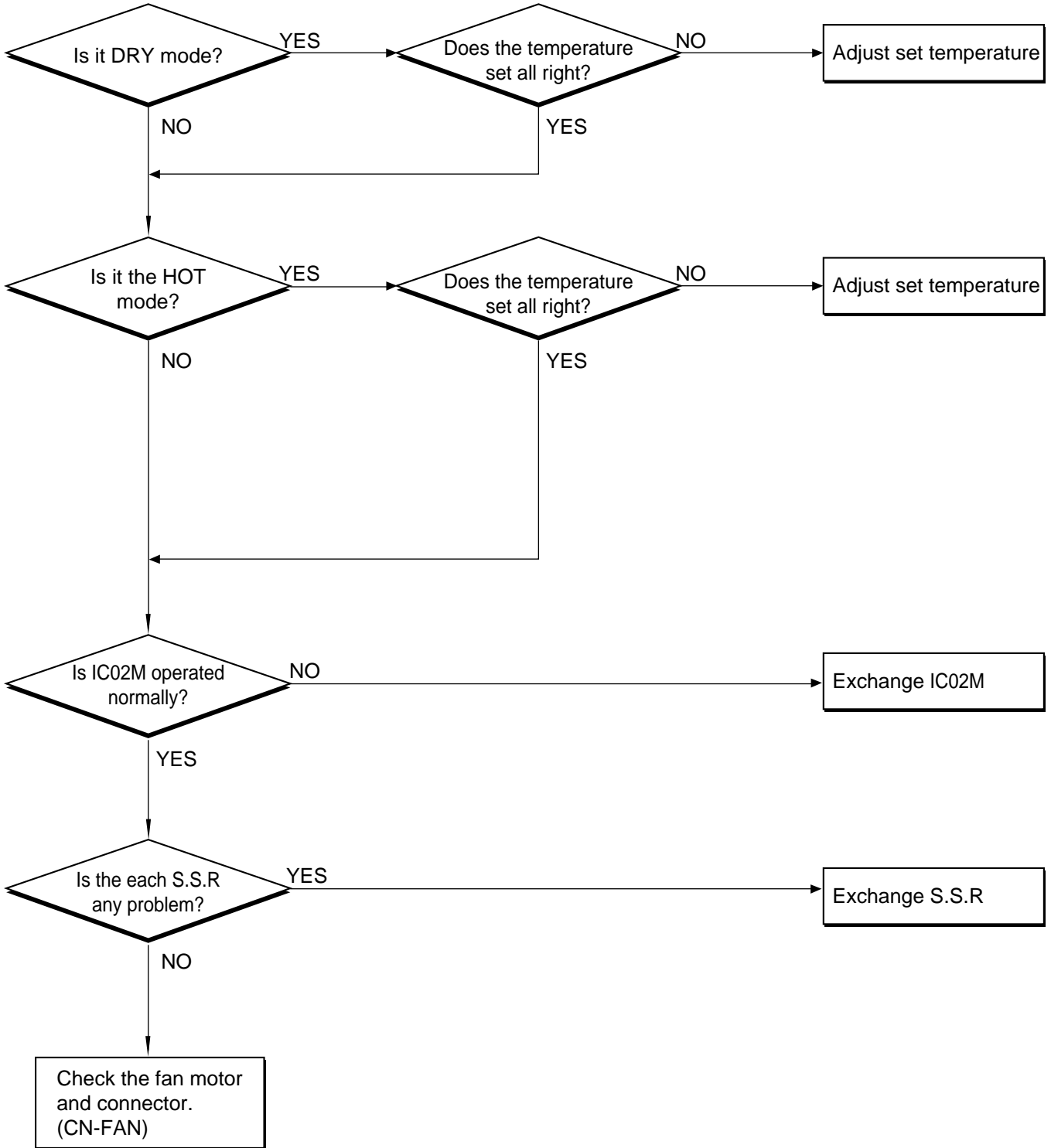

**Possible Trouble 3** : Up/Down Air direction louver does not operate.

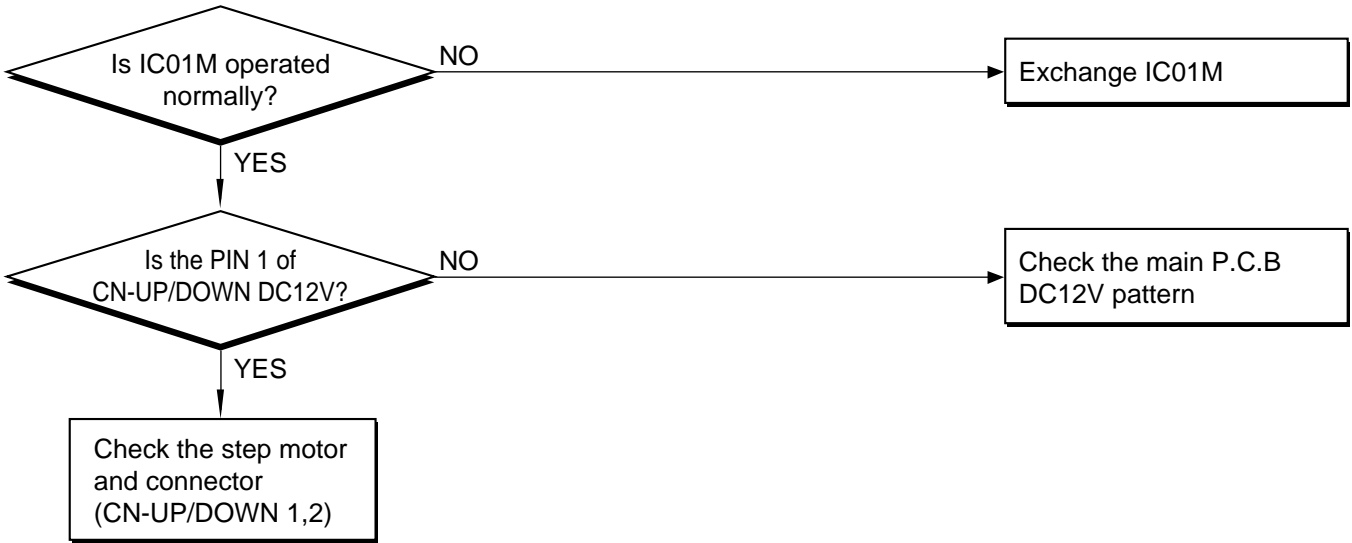

**Possible Trouble 4** : Remote controller does not operate.

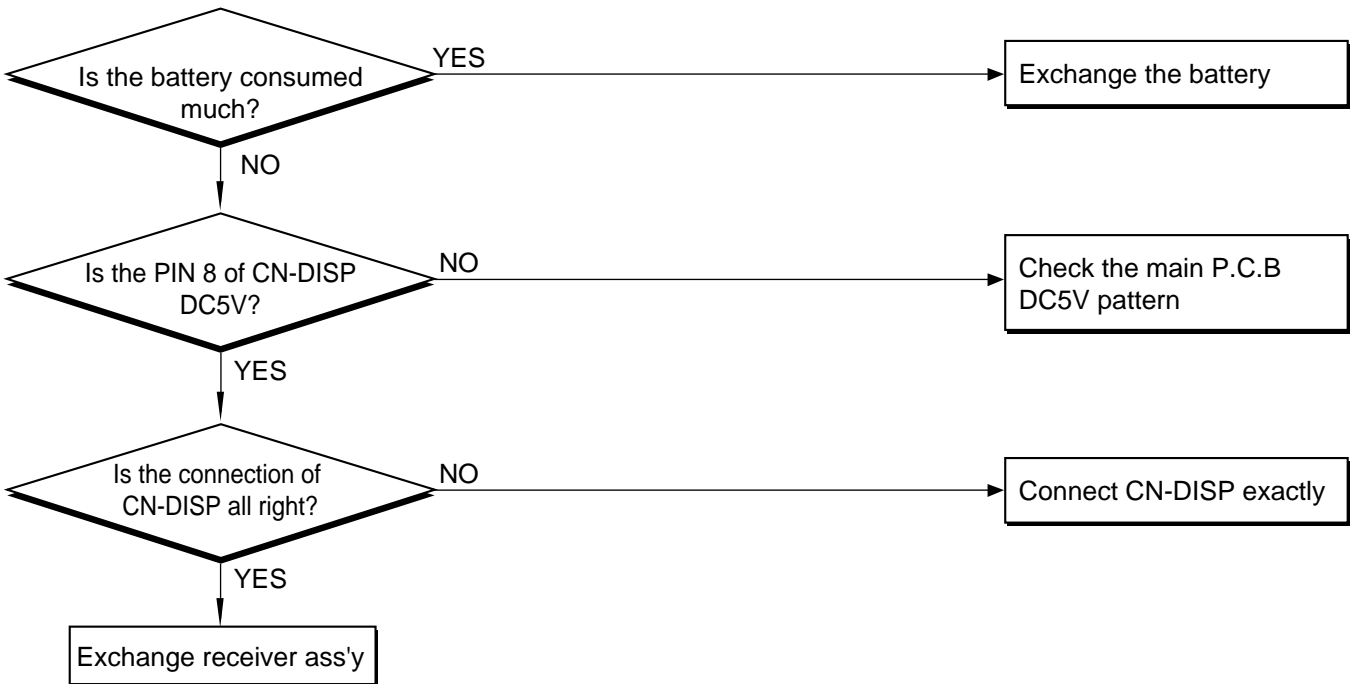

**Possible Trouble 5** : Ineffective Heating

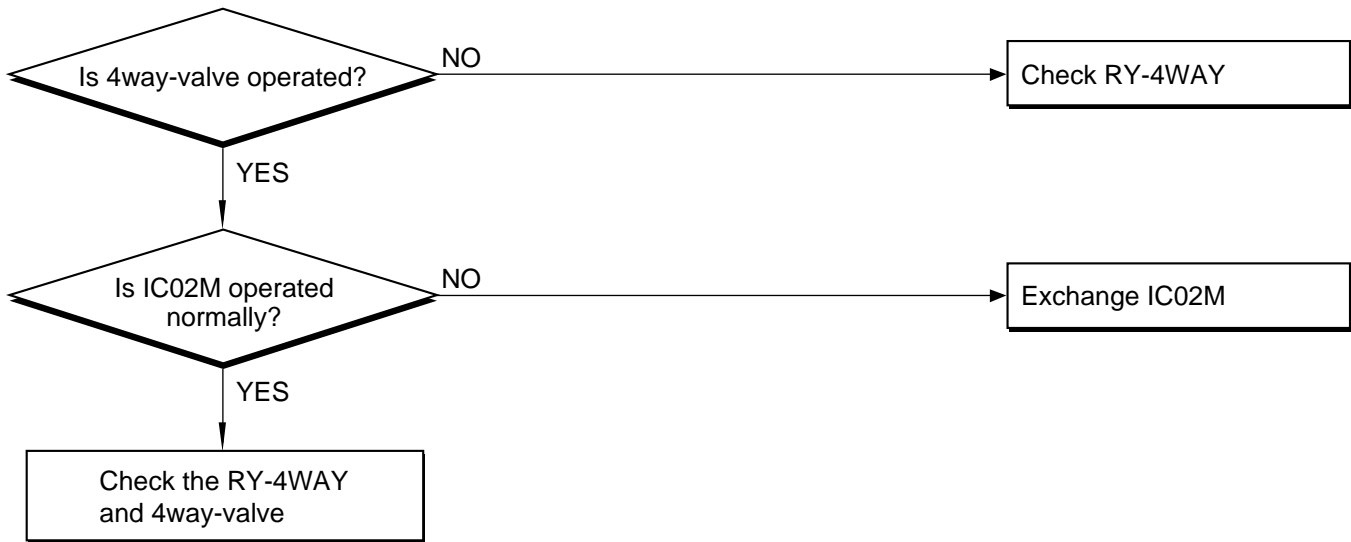

**Possible Trouble 6** : The unit does not operate by forced operation switch.







# Schematic Diagram

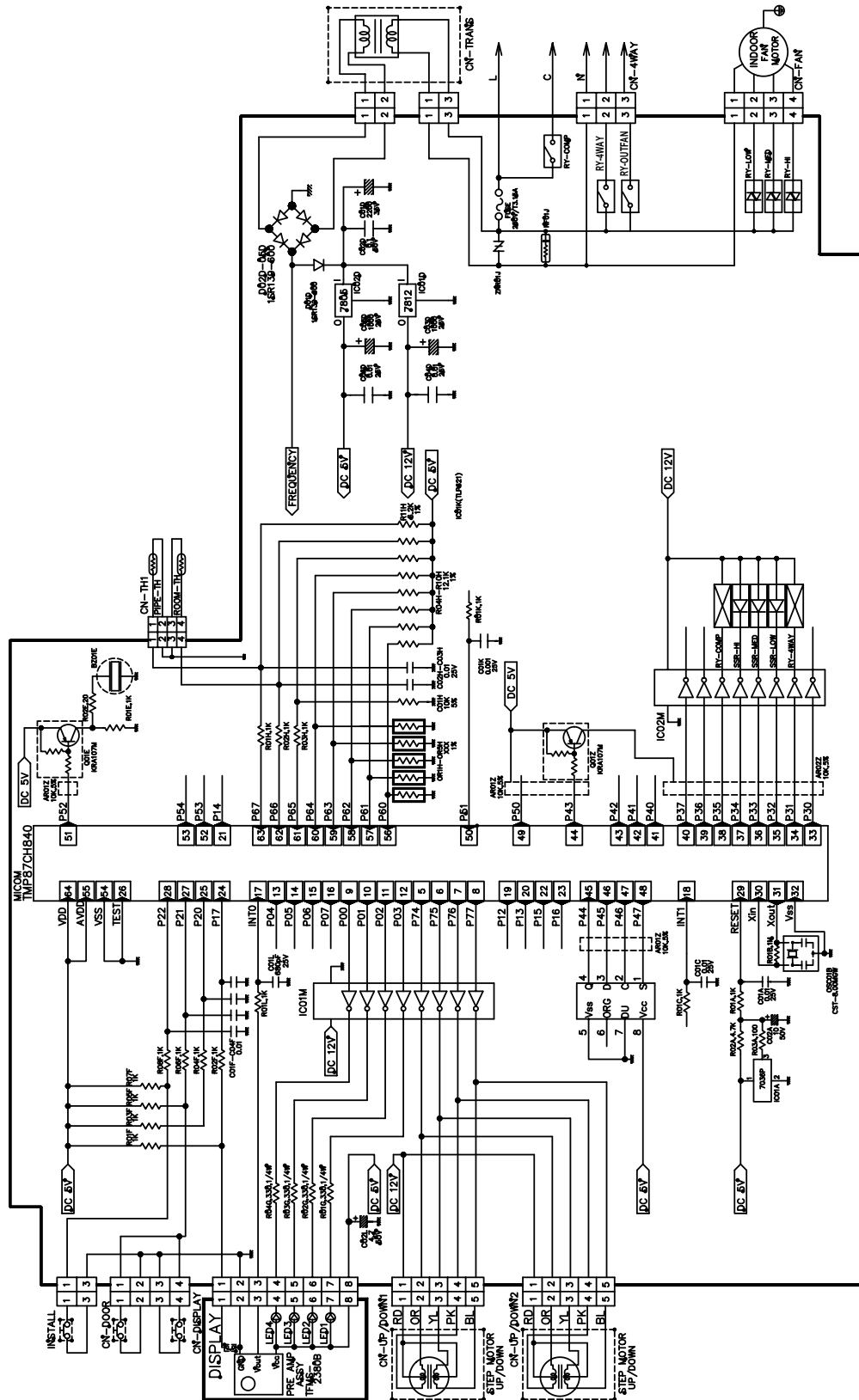

# Exploded View and Replacement Parts List

## 1. Indoor Unit

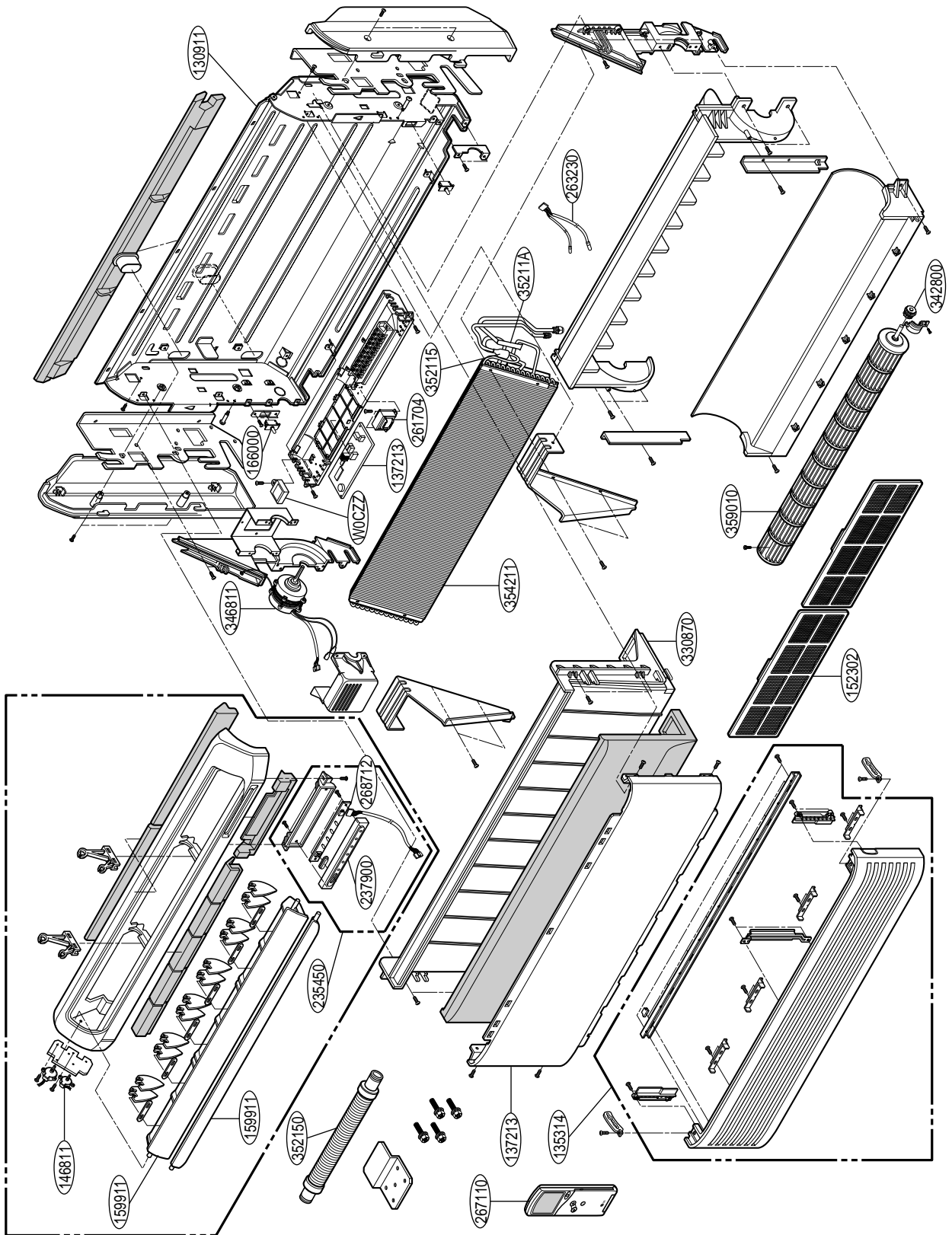

## Parts List (Cooling Only Models)

LOCATION NO.	DESCRIPTION	PART No.			REMARK
		LV-B1861CL	LV-B1864CL	LV-B2461CL LV-B2464CL	
130911	CABINET ASSY	3091AP2533A		3091AP2533A	
135314	GRILLE ASSY, INLET SUB	5237AP2817B		5237AP2817B	
137213	PANEL ASSY, SIDE	3720AP2767P		3720AP2767P	
137213	PWB(PCB) ASSY, MAIN	6871A20042D	6871A20042L	6871A20042D	
146811	MOTOR ASSY, STEP	4681AR2727G		4681AR2727G	
152302	FILTER(MECH), A/C	5230AP7093A		5230AP7093A	
159911	VANE ASSY, HORIZONTAL	5991AP2867B		5991AP2867B	
159911	VANE ASSY	5991AP7334C		5991AP7334C	
166000	SWITCH, PUSH	6600AP2059B		6600AP2059B	
235450	DISPLAY ASSY (MECH)	3545AP7224A		3545AP7224A	
237900	WINDOW, DISPLAY	3790AP7080A		3790AP7080A	
261704	TRANSFORMER, POWER	6171AQ3198E		6171AQ3198E	
263230	THERMISTOR ASSY	6323AQ2333Y		6323AQ2333J	
267110	REMOTE CONTROLLER ASSY	6711A20010J		6711A20010J	
268712	PWB(PCB) ASSY, DISPLAY	6871AQ3263A		6871AQ3263A	
330870	DRAIN PAN ASSY	3087AP7233A		3087AP7233A	
342800	BEARING	3H02821A		3H02821A	
346811	MOTOR ASSY, INDOOR	4681AP2306G		4681AP2306E	
352115	TUBE ASSY, EVA-IN	5211AP2810G	5211AP2810K	5211AP2810A	
35211A	TUBE ASSY, SUCTION INDOOR	5211AP2813C		5211AP2813A	
352150	HOSE ASSY, DRAIN	5251AP2460B		5251AP2460B	
354211	EVAPORATOR ASSY	5421AP2812B		5421AP2812A	
359010	FAN ASSY, CROSS FLOW	5901AR2351E		5901AR2351E	
W0CZZ	CAPACITOR	3H00671A		3H00671A	

## Parts List (Heat Pump Models)

LOCATION NO.	DESCRIPTION	PART No.				REMARK
		LV-B1861HL	LV-B1864HL	LV-B2461HL	LV-B2464HL	
130911	CABINET ASSY	3091AP2533A		3091AP2533A	3091AP2533A	
135314	GRILLE ASSY, INLET SUB	5237AP2817B		5237AP2817B	5237AP2817B	
137213	PANEL ASSY, SIDE	3720AP2767P		3720AP2767P	3720AP2767P	
137213	PWB(PCB) ASSY, MAIN	6871A20042A	6871A20042K	6871A20042A	6871A20042K	
146811	MOTOR ASSY, STEP	4681AR2727G		4681AR2727G	4681AR2727G	
152302	FILTER(MECH), A/C	5230AP7093A		5230AP7093A	5230AP7093A	
159911	VANE ASSY, HORIZONTAL	5991AP2867B		5991AP2867B	5991AP2867B	
159911	VANE ASSY	5991AP7334C		5991AP7334C	5991AP7334C	
166000	SWITCH, PUSH	6600AP2059B		6600AP2059B	6600AP2059B	
235450	DISPLAY ASSY (MECH)	3545AP7224A		3545AP7224A	3545AP7224A	
237900	WINDOW, DISPLAY	3790AP7080A		3790AP7080A	3790AP7080A	
261704	TRANSFORMER, POWER	6171AQ3198E		6171AQ3198E	6171AQ3198E	
263230	THERMISTOR ASSY	6323AQ2333J		6323AQ2333Y	6323AQ2333Y	
267110	REMOTE CONTROLLER ASSY	6711A20010K		6711A20010K	6711A20010K	
268712	PWB(PCB) ASSY, DISPLAY	6871AQ3263A		6871AQ3263A	6871AQ3263A	
330870	DRAIN PAN ASSY	3087AP7233A		3087AP7233A	3087AP7233A	
342800	BEARING	3H02821A		3H02821A	3H02821A	
346811	MOTOR ASSY, INDOOR	4681AP2306G		4681AP2306E	4681AP2306E	
352115	TUBE ASSY, EVA-IN	5211AP2810C	5211AP2810K	5211AP2810E	5211AP2810J	
35211A	TUBE ASSY, SUCTION INDOOR	5211AP2813C		5211AP2813A	5211AP2813A	
352150	HOSE ASSY, DRAIN	5251AP2460B		5251AP2460B	5251AP2460B	
354211	EVAPORATOR ASSY	5421AP2812B		5421AP2812A	5421AP2812A	
359010	FAN ASSY, CROSS FLOW	5901AR2351E		5901AR2351E	5901AR2351E	
W0CZZ	CAPACITOR	3H00671A		3H00671A	3H00671A	

## 2. Outdoor Unit

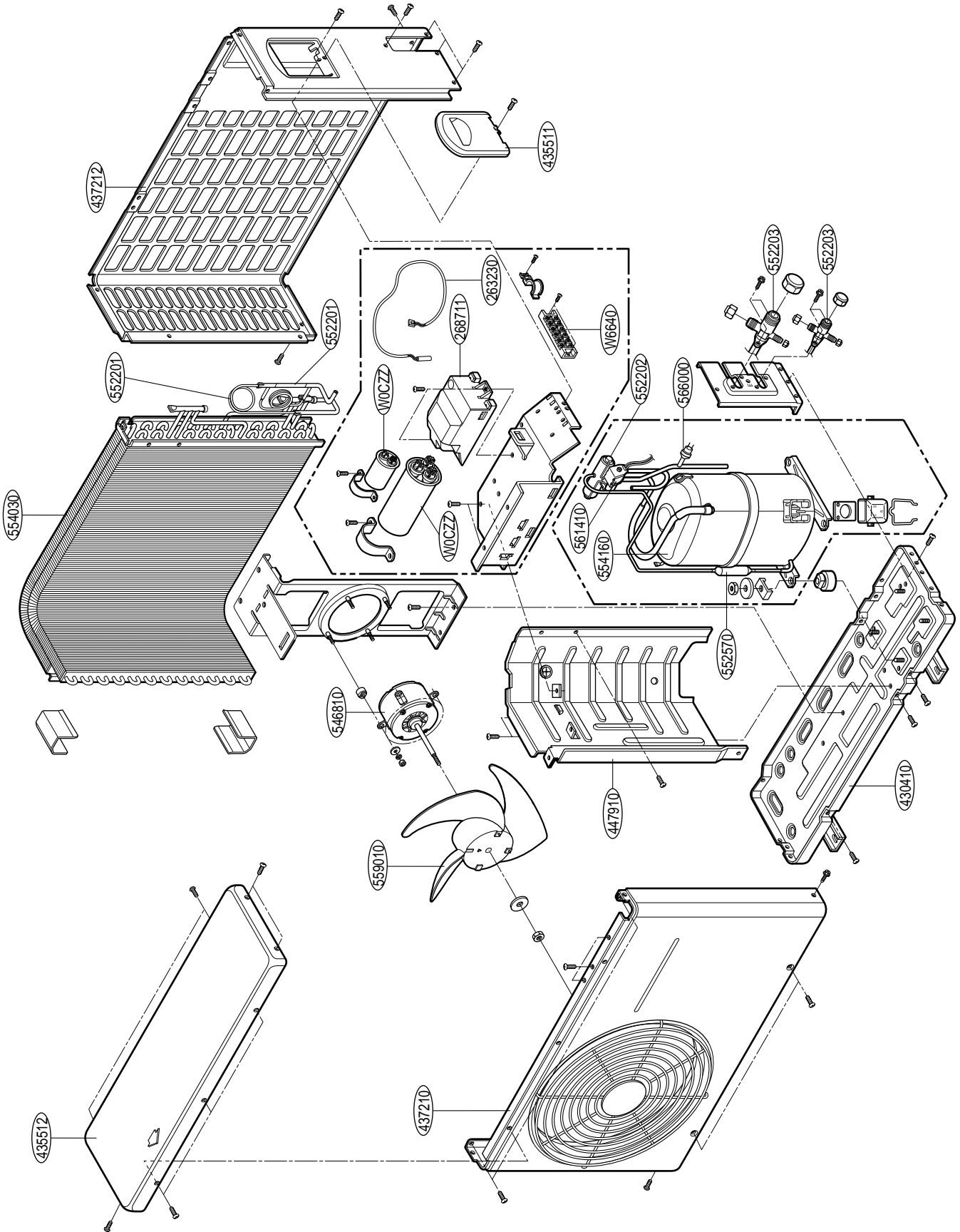

## Parts List (Cooling Only Models)

LOCATION NO.	DESCRIPTION	PART No.			REMARK
		LV-B1861CL	LV-B1864CL	LV-B2461CL LV-B2464CL	
430410	BASE ASSY, WELD(OUTDOOR)	3041A30003K	3041A30003U	3041A30003K	
435511	COVER ASSY, CONTROL(OUTDOOR)	3A01919B		3A01919B	
435512	COVER ASSY, TOP(OUTDOOR)	3H03266K		3H03266K	
437210	PANEL ASSY, FRONT(OUTDOOR)	3721A20005F		3721A20005F	
437212	PANEL ASSY, REAR	3720AP0003D		3720AP0003D	
447910	BARRIER ASSY, OUTDOOR	2H02110A		2H02110A	
546810	MOTOR ASSY, OUTDOOR	4681A20013A	4681A20013D	4681A20013D	
552101	TUBE, CAPILLARY	5424AR3448C	5424AR3448E	-	
552201	TUBE, CAPILLARY	-		3H01535Y	
552203	VALVE, SERVICE	2H01890K	2H01890D	2A00392K	
552203	VALVE, SERVICE	2H02479B		2H02479B	
552570	MUFFLER	3A90082B	-	-	
554030	CONDENSER ASSY, BENT	5402AR2347H		5402AR2347D	
554160	COMPRESSOR	2A00715N	5416A20016A	2A00715P	
559010	FAN ASSY, PROPELLER	1A00195B		1A00195B	
W0CZZ	CAPACITOR	6120AR2194F	6120AR2194K	6120AR2359X	
W6640	TERMINAL BLOCK	4G00103C		4G00103C	
W6640	TERMINAL BLOCK	3H00390B		3H00390B	

## Parts List (Heat Pump Models)

LOCATION NO.	DESCRIPTION	PART No.				REMARK
		LV-B1861HL	LV-B1864HL	LV-B2461HL	LV-B2464HL	
263230	THERMISTOR ASSY	3Q35015E	-	3Q35015H	-	
268711	PWB(PCB) ASSY, DEICER	6871A20015F	-	6871A20015Q	-	
430410	BASE ASSY, WELD[OUTDOOR]	3041A30003K	3041A30003U	3041A30003K	3041A30003K	
435511	COVER ASSY, CONTROL(OUTDOOR)	3551A30007W	3A01919B	3A01919B	3A01919B	
435512	COVER ASSY, TOP(OUTDOOR)	3H03266J	3H03266K	3H03266K	3H03266K	
437210	PANEL ASSY, FRONT(OUTDOOR)	3721A20005F		3721A20005F	3721A20005F	
437212	PANEL ASSY, REAR	3720AP0003D		3720AP0003D	3720AP0003D	
447910	BARRIER ASSY, OUTDOOR	2H02110A		2H02110A	2H02110A	
546810	MOTOR ASSY, OUTDOOR	4681A20013F	4681A20013D	4681A20013D	4681A20013D	
552201	VALVE, CHECK	3A01020H		3A01020H	3A01020H	
552201	TUBE, CAPILLARY	3H01535G	3H01535R	3H01535R	3H01535R	
552202	VALVE, REVERSING	3A02027A		3A02027A	3A02027A	
552203	VALVE, SERVICE	2H01890D		2A00392E	2A00392E	
552203	VALVE, SERVICE	2H02479B		2H02479B	2H02479B	
552570	MUFFLER	3A90082A	5211A20030C	3A90082A	3A90082A	
554030	CONDENSER ASSY, BENT	5402AR2347B	5403A20022F	5403A20022F	5403A20022F	
554160	COMPRESSOR	5416AR1411G	5416A20016A	5416AR1411H	5416AR1411H	
559010	FAN ASSY, PROPELLER	1A00195B		1A00195B	1A00195B	
561410	COIL ASSY, REVERSING VALVE	3A02028Y		3A02028Y	3A02028Y	
566000	SWITCH, PRESSURE	3A02524C	-	3A02524C	-	
W0CZZ	CAPACITOR	2A00986D	6120AR2194K	2A00986A	6120AR2194K	
W0CZZ	CAPACITOR	2A00986W	-	2A00986D	-	
W6640	TERMINAL BLOCK	4G00103A		3H00390B	4G00103A	
W6640	TERMINAL BLOCK	-	3H00390B	-	3H00390B	

