

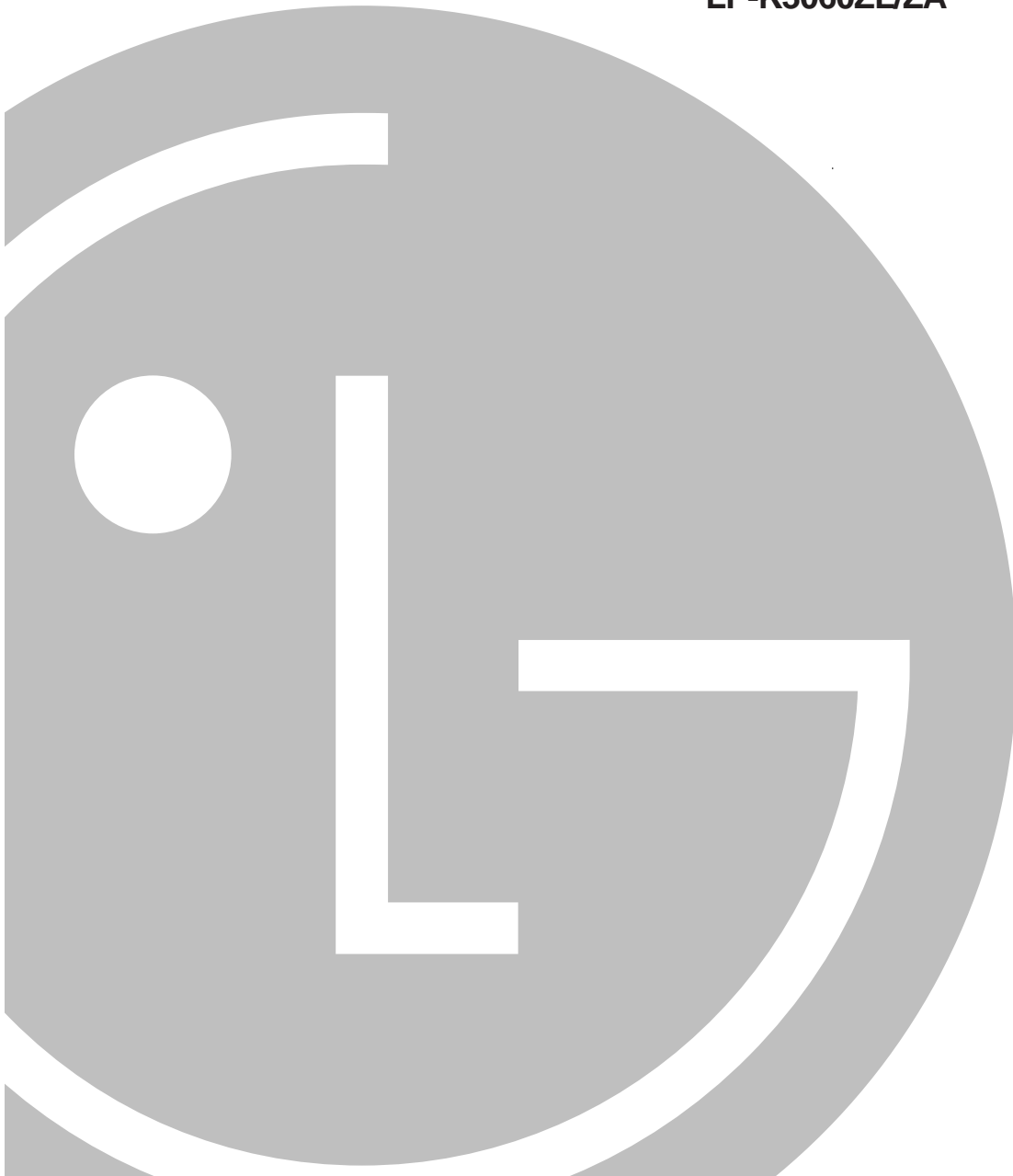

Package Air Conditioner SERVICE MANUAL

MODEL: LP-K3020HL/HA
LP-K3060HL/HA
LP-K3060ZL/ZA



Contents

Functions	3
Product Specifications	6
Dimensions	7
Refrigeration Cycle Diagram	7
Wiring Diagram	8
Operation Details	9
Installation of Indoor, Outdoor Unit	15
Test Running	26
3-way Valve	28
Cycle Troubleshooting Guide	34
Electronic Parts Troubleshooting Guide	35
Electronic Control Device	38
Schematic Diagram	39
Exploded View and Replacement Parts List	40

Functions

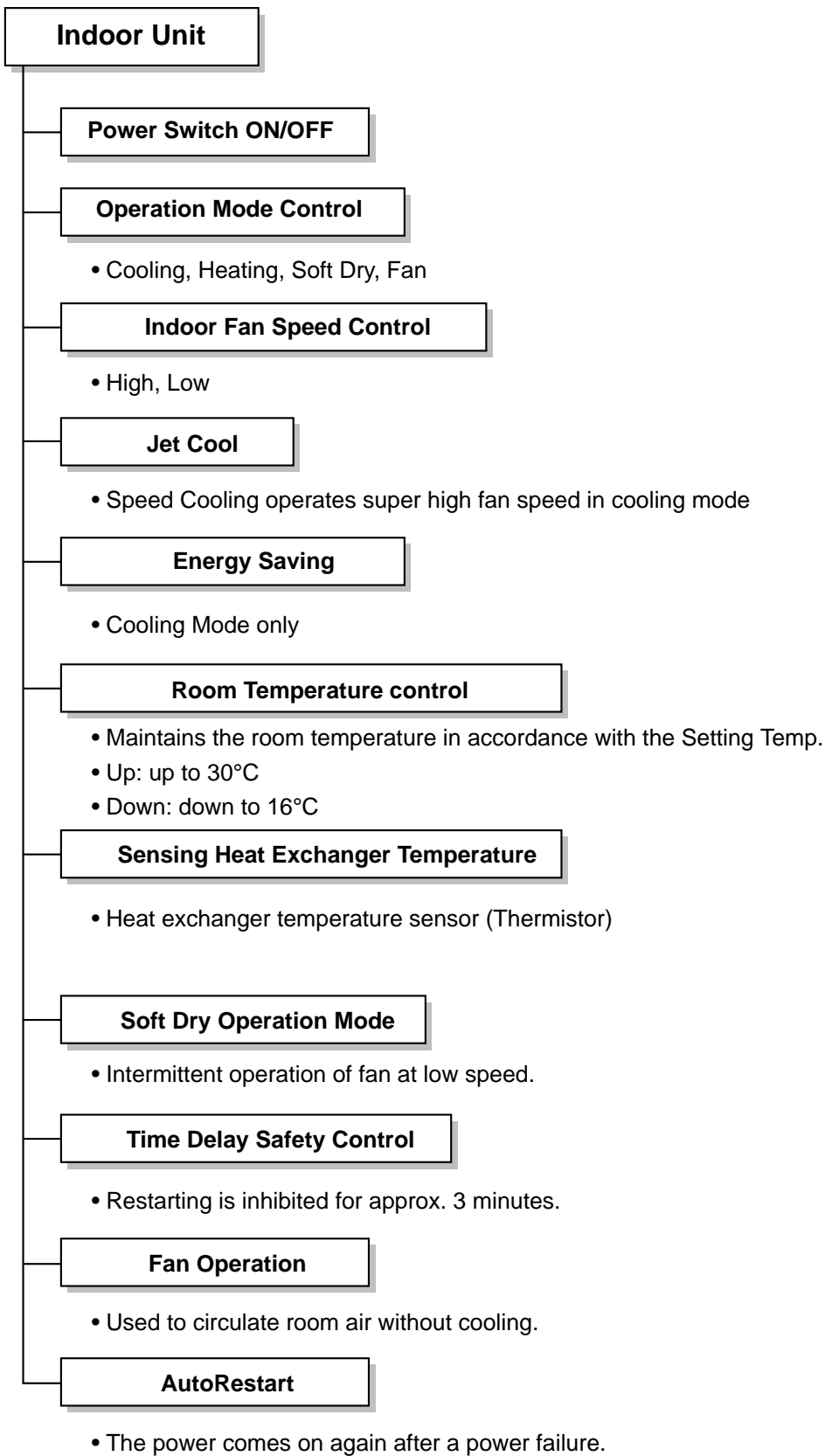

Remote Control

Operation ON/OFF

Cooling Operation Mode

Heating Operation Mode

Sot Dry Operation Mode

- Intermittent operation of fan at low speed.

Fan Operation

- Used to circulate room air without cooling.

Timer Control

- OFF Timer (1, 2, 3,.....7 hour)

Jet Cool

- Speed cooling operates super high fan speed in cooling mode.

Energy Saving

Airflow Direction Control

- Airflow direction Auto-swing and Manual Control.

Room Temperature Control

- Up: up to 30°C
- Down: down to 16°C

Indoor Fan speed control

- High, Low
- High, Low

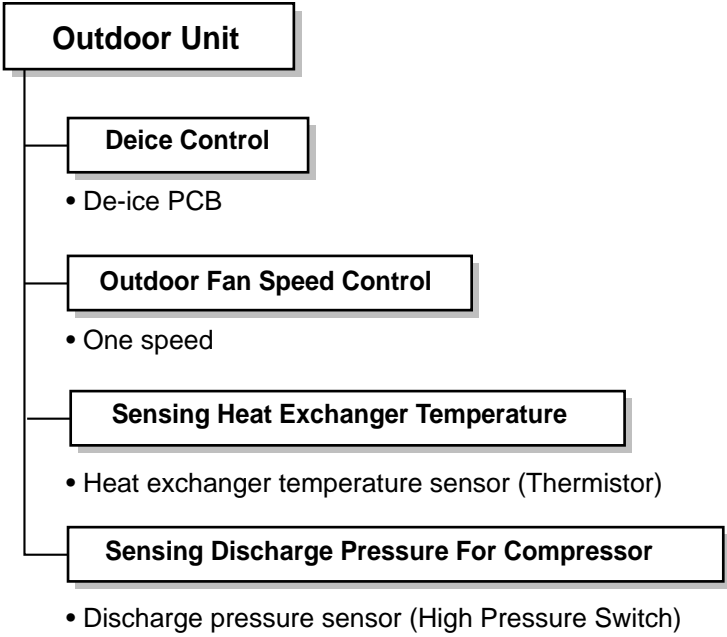

Product Specifications

ITEMS		MODEL		LP-K3060HL/HA LP-K3060ZL/ZA	LP-K3020HL/HA
		UNIT			
POWER SUPPLY Ø, V, Hz				1, 220-240, 50	1, 220,60
COOLING CAPACITY		Btu/hr		27,800	27,800
HEATING CAPACITY (Incl. elec. Heater)		Btu/hr		27,800 + (2kw)	27,800
POWER INPUT	COOLING	W		3,000	3,500
	HEATING	W		2,800	-
RUNNING CURRENT	COOLING	A		14.5	17
	HEATING	A		13.5	-
COMPRESSOR	MODEL		H25B35QABHA		AWG5532EXN
	MAKER		BRISTOL		TELUMSEH
	TYPE		RECIPRO		RECIPRO
	CAPACITY	Btu/hr		30,200	31,500
	INPUT	(KW)		2.83	3.3
	LRA	A		85	90
NOISE LEVEL	INDOOR	dB(A)		48	48
	OUTDOOR	dB(A)		58	58
AIR CIRCULATION	INDOOR	CFM/CMM		670/19	670/19
	OUTDOOR	CFM/CMM		2,225/63	2,225/63
REFRIGERANT (R-22)		OZ(kg)		86.7(2.46)	82.9(2.35)
HEAT EXCHANGER	INDOOR	R/C/FPI		3/22/18	3/22/18
	OUTDOOR	R/C/FPI		2/30/16	2/30/16
FAN	INDOOR	TYPE		SIROCO	SIROCO
	OUTDOOR	TYPE		PROPELLER	PROPELLER
ROOM TEMPERATURE CONTROL			MICOM CONTROL		MICOM CONTROL
D I M E N S I O N S	INDOOR	WIDTH	inch(mm)	19.68(500)	19.68(500)
		HEIGHT		70.86(1800)	70.86(1800)
		DEPTH		12.59(320)	12.59(320)
	OUTDOOR	WIDTH	inch(mm)	34.25(870)	34.25(870)
		HEIGHT		31.49(800)	31.49(800)
		DEPTH		12.59(320)	12.59(320)
NET WEIGHT	INDOOR	lb(kg)		88.18(40)	88.18(40)
	OUTDOOR	lb(kg)		143.2(65)	143.2(65)
CONNECTIONS	LIQUID	inch(mm)		3/8"(Ø9.52)	3/8"(Ø9.52)
	GAS	inch(mm)		5/8"(Ø15.88)	5/8"(Ø15.88)

Dimensions

Indoor Unit

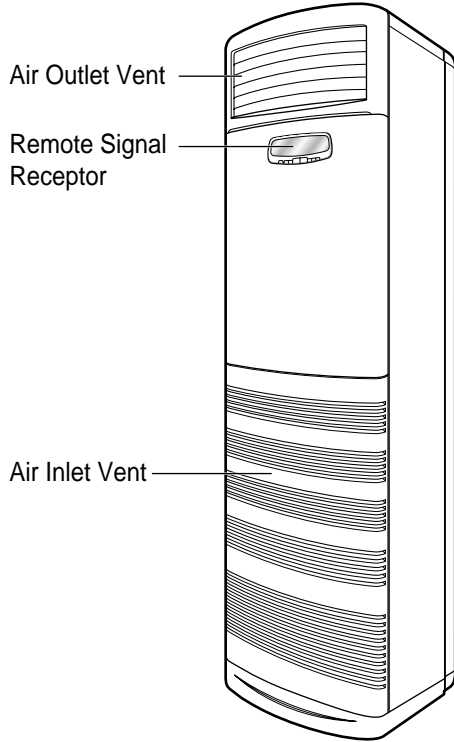

Outdoor Unit

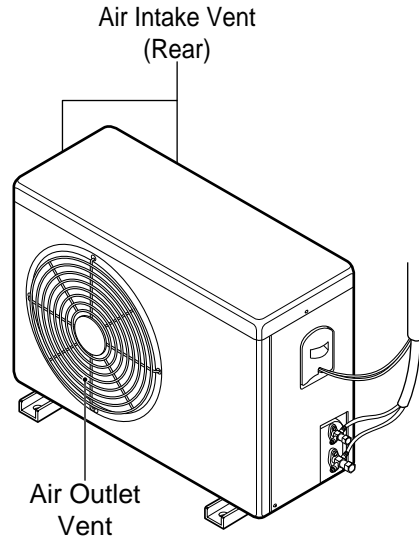

Refrigeration Cycle Diagram

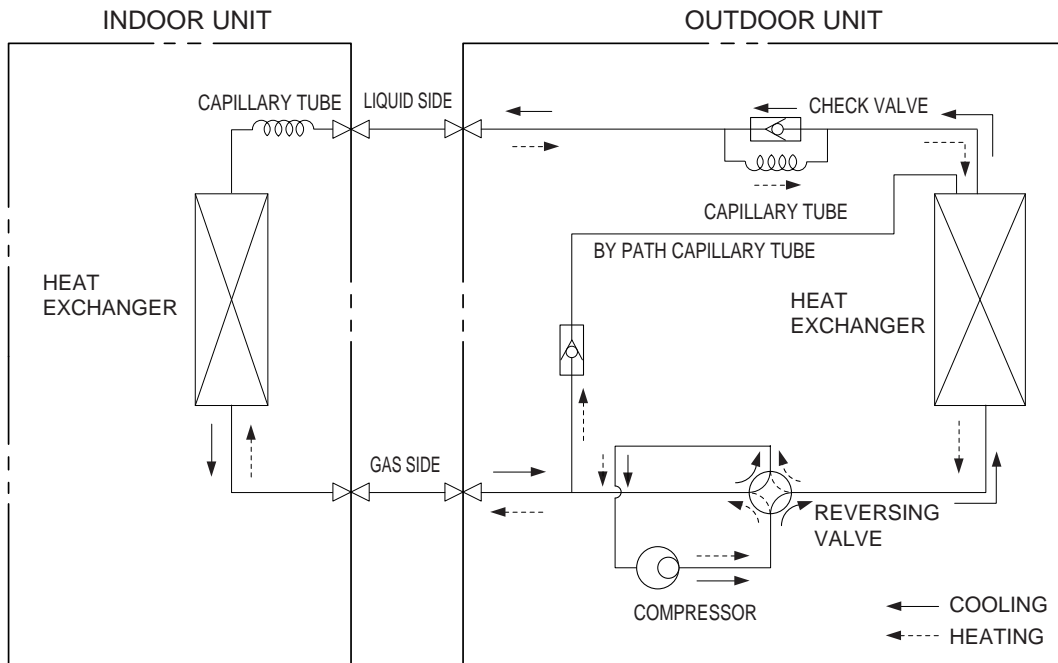

Wiring Diagram

(1) LP-K3060HL/HA/ZL/ZA

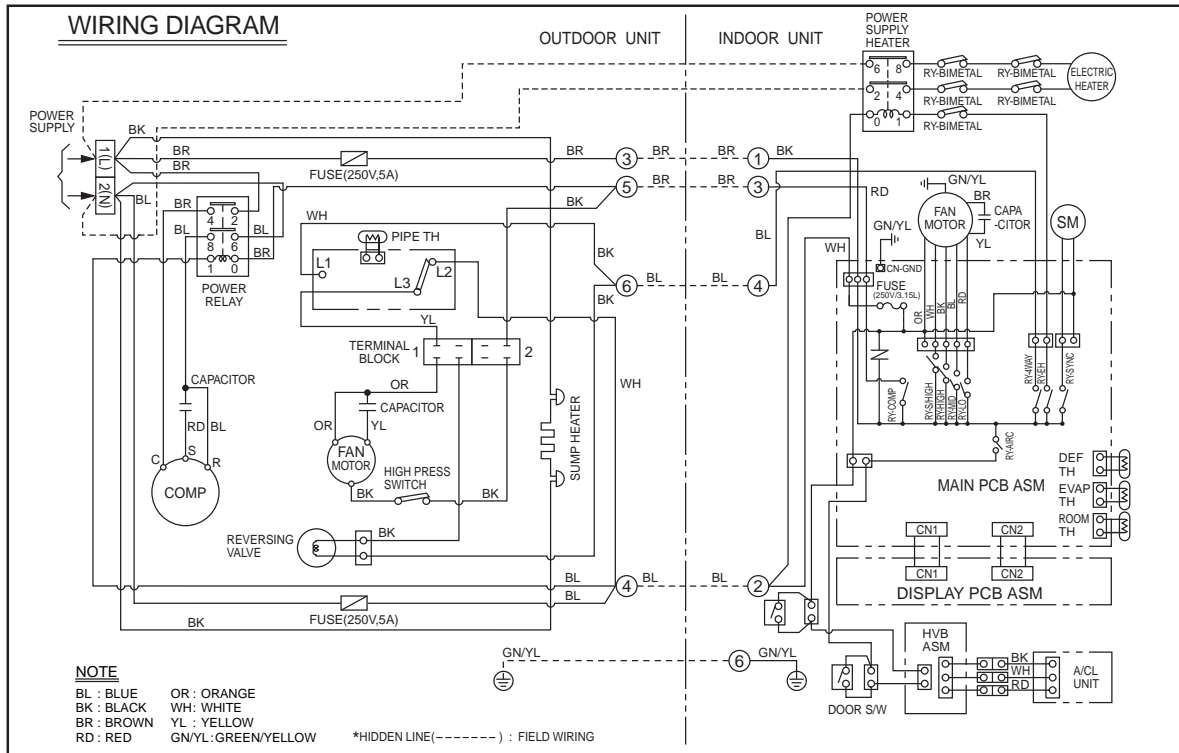

(2) LP-K3020HL/HA

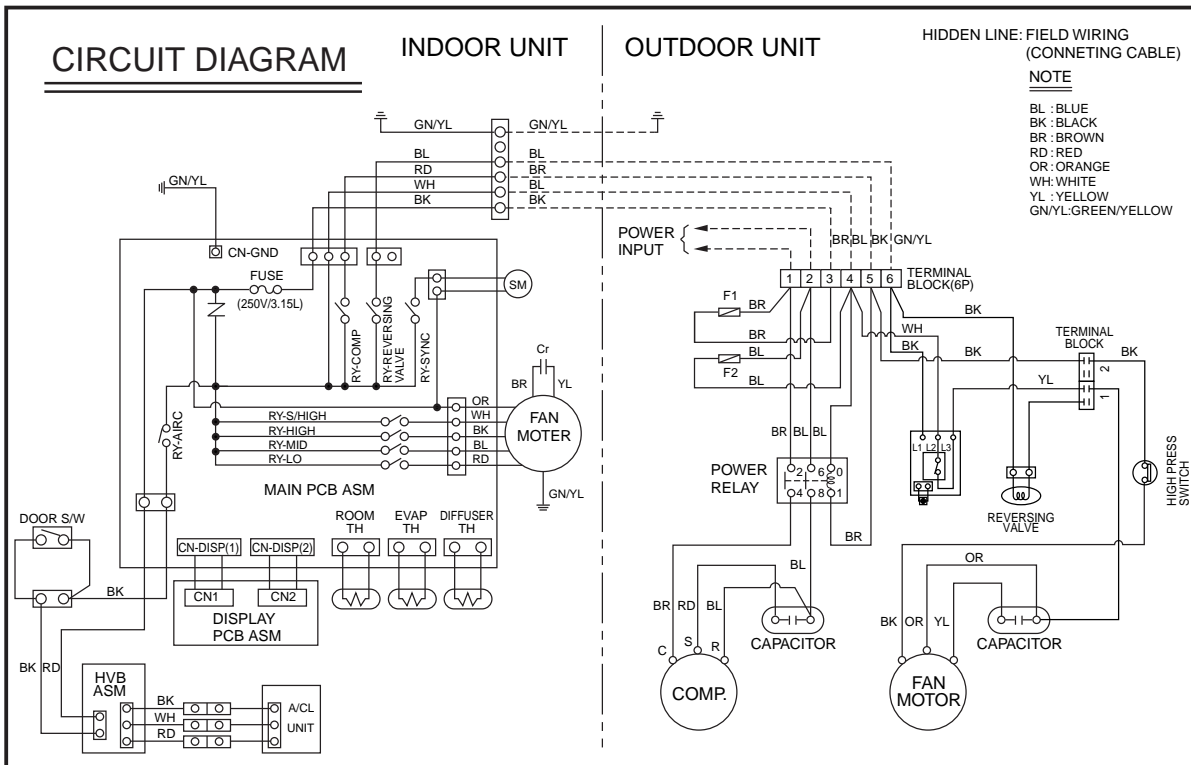

Operation Details

(1) The function of main control

1. Time Delay Safety Control

f \cup 3min ; *f* The compressor is ceased for 3 minutes to balance the pressure in the refrigeration cycle.

(Protection of compressor)

f \cup 3sec ; *f* The indoor fan is ceased for 3 seconds to prevent relay noise.

(Protection of fan relay and micro chip)

f \cup 30sec ; *f* The 4-way valve is ceased for 30 sec. to prevent the refrigerant-gas abnormal noise when the Heating operation is OFF or switched to the other operation mode.

2. Airflow Direction Control

f \cup This function is to swing the louver left and right automatically and to set it at the desired position.

f \cup The procedure is as the following.

1st : Press the ON/OFF Button to operate the product.

2nd : Press the Airflow Direction Control Button to swing the louver left and right automatically.
(Remote controller)

3rd : Re-press the Airflow Direction Control Button to set the louver as the desired position.
(Remote controller)

3. Cooling Mode Operation

f \cup When selecting the Cooling (❄) Mode Operation, the unit will operate according to the setting by the controller and the operation diagram is as following.

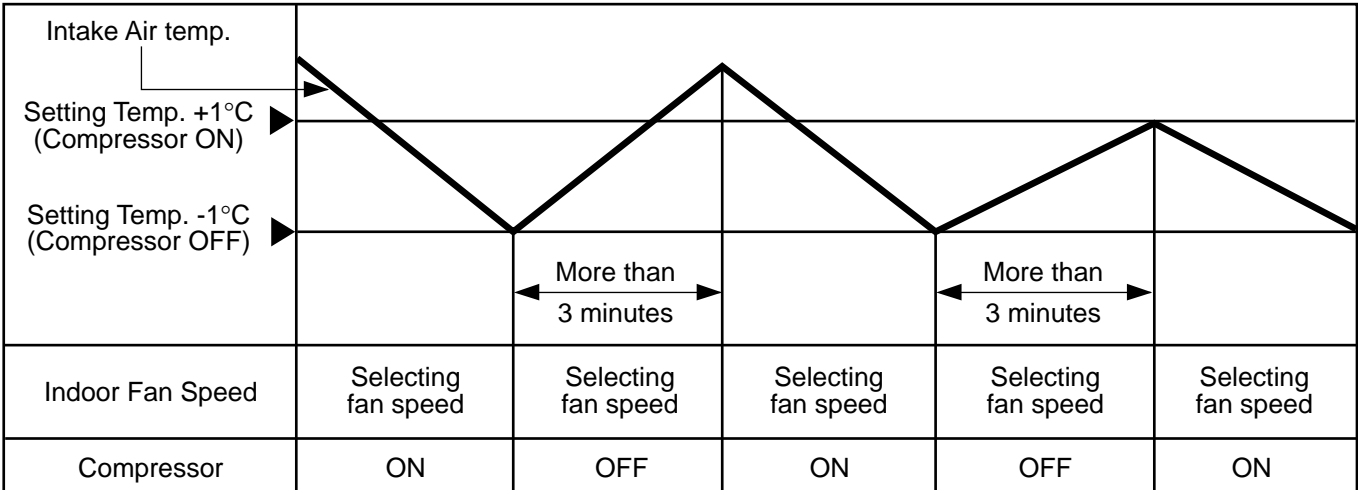

4. Off Timer Function

This function is to set the time of stopping the unit operation.

The procedure is as the following.

1st: Press the timer set button on the Remocon.

2nd: The buzzer sounds and then the display window shows the Off-Time to be set as 1 → ... → 7 → 0

- The Off-Time is shifted as the following by each press.

→ 1 → 2 → 3 → 4 → 5 → 6 → 7 → 0

- If you select '0', the Off-Timer function will be cancelled.

- During Off-Timer Operation, if you repress the timer set button, the rest time will be displayed.

5. Heating Mode Operation

The unit will operate according to the setting by the remote controller and the operation diagram is shown as following.

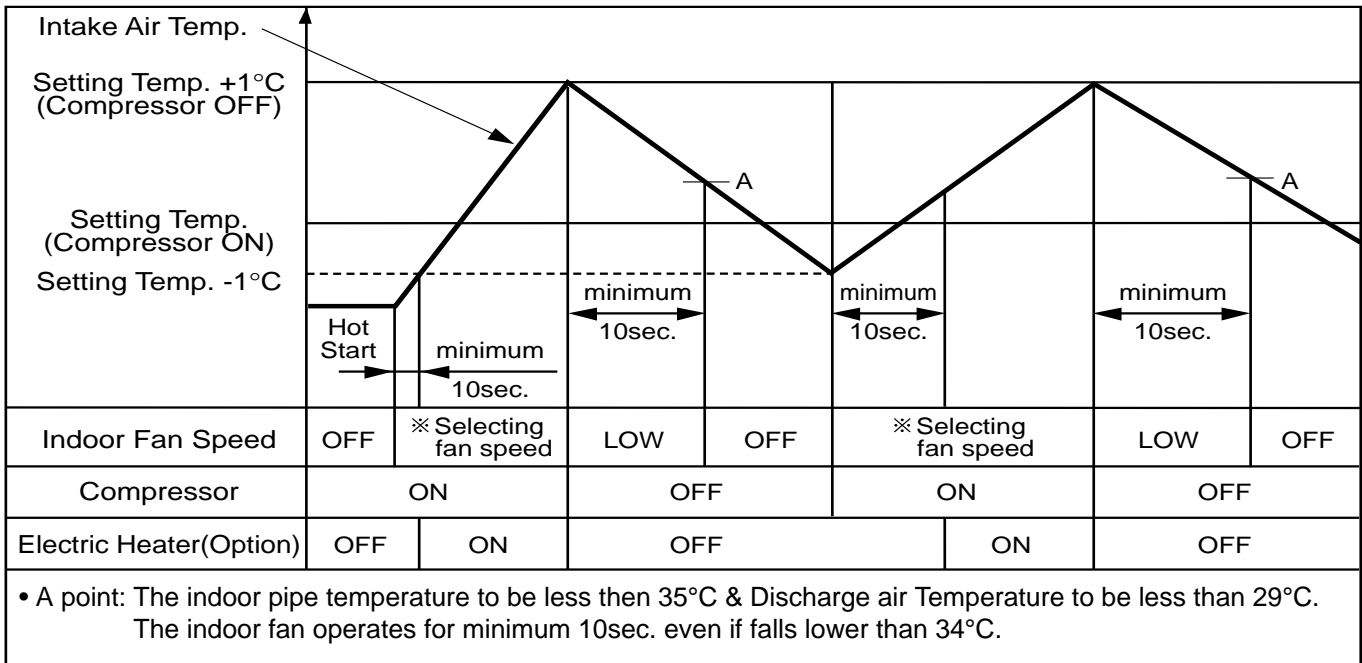

i During heating operation, the operating procedure of the indoor fan is as the following.

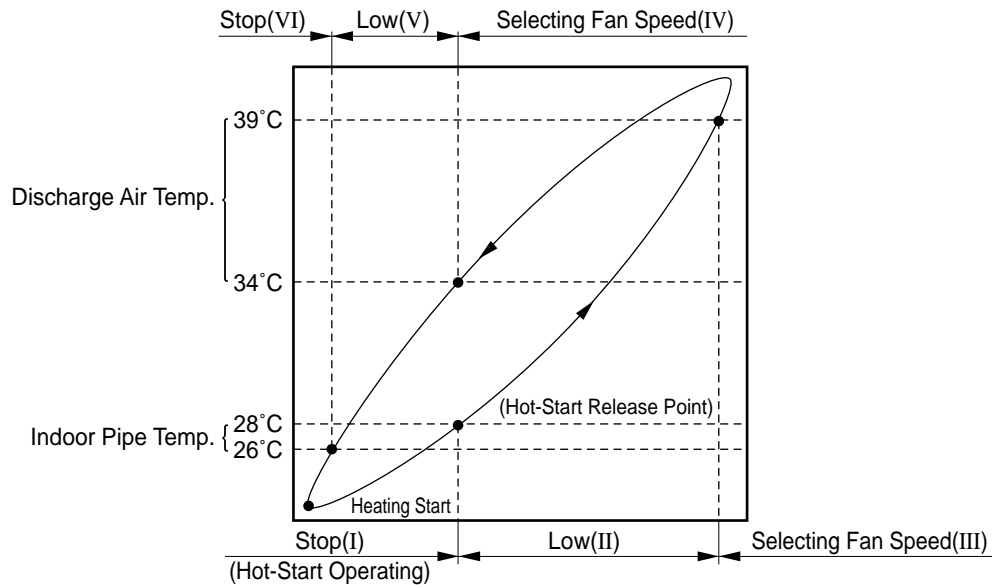

Step	Indoor fan speed	Pipe temp.	Air discharge temp.
¥	Off	i 28 i € (Hot start operating)	-
¥-	Low	i 28 i €	< 39°C
¥†	Selecting speed	i 28 i €	≥ 39°C
¥‡	Selecting speed	i 28 i €	> 34°C
¥·	Low	i 26 i €	≤ 34°C
¥	Off	i 26 i €	-

6. Hot-Start Control

- The indoor fan stops until the evaporator piping temperature will be reached to 28°C.
- During heating operation, if piping temperatures fall below 26°C fan stops.
- The operation diagram is as following.

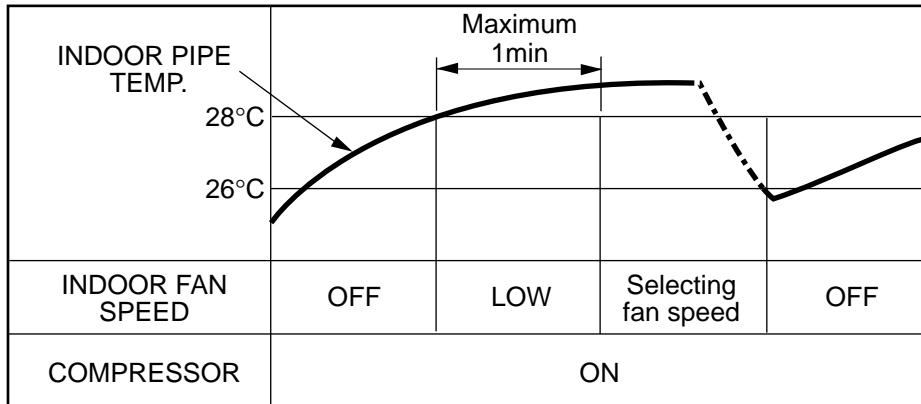

7. Defrost Control

- Defrost operation is controlled by timer and sensing temperature of outdoor pipe.
- The first defrost starts only when the outdoor pipe temperature falls below -6°C after 45 minutes passed from starting of heating operation and more than.
- Defrost ends after 10 minutes pass from starting of defrost operation or when the outdoor pipe temperature rises over 12°C even if before 10 minutes.
- The second defrost starts only when the outdoor pipe temperature falls below -6°C after 45 minutes pass from ending of the first defrost and more than.

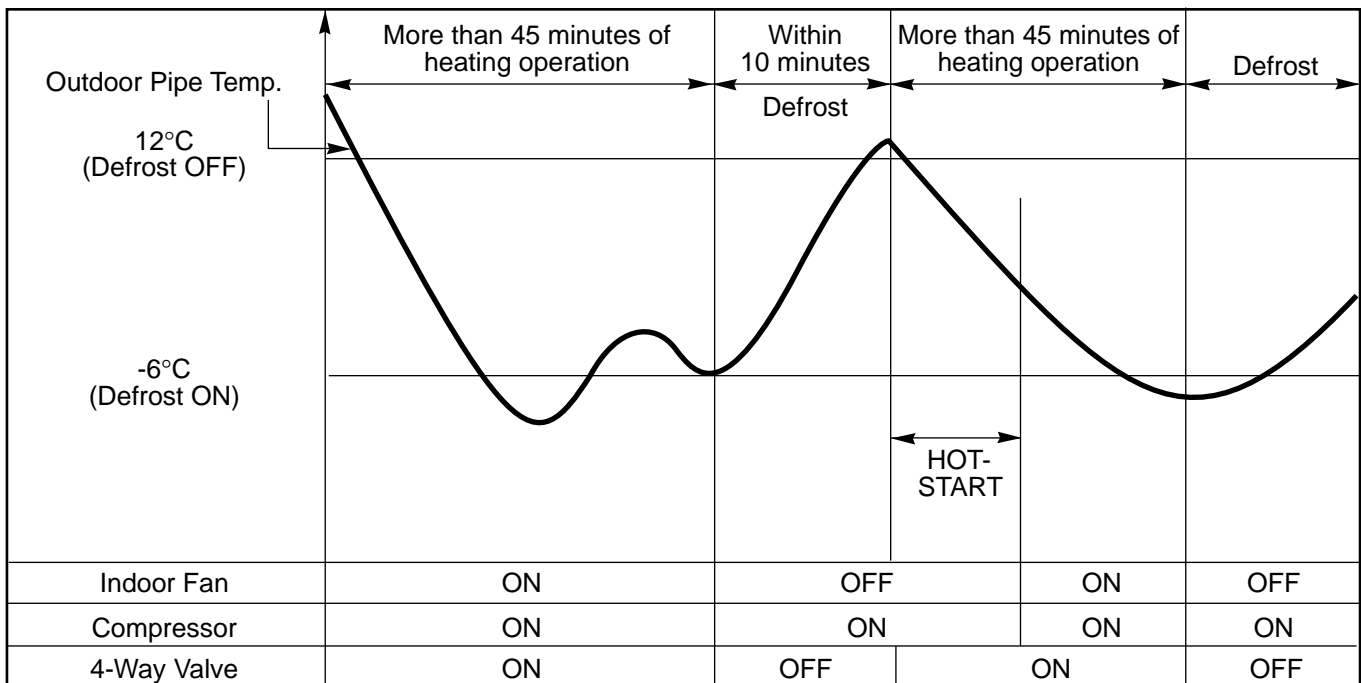

8. Soft Dry Operation Mode

- During Soft Dry Operation, the compressor ON temperature is the setting temperature plus 2°C, the compressor OFF temperature is the setting temperature minus 1°C.
- When the room temperature rises over the compressor ON temperature, the operation mode is switched to the Cooling mode.
- When the room temperature falls between the compressor ON temperature and OFF temperature, the operation mode is switched to the Soft Dry Operation.
- The operation diagram is shown below.

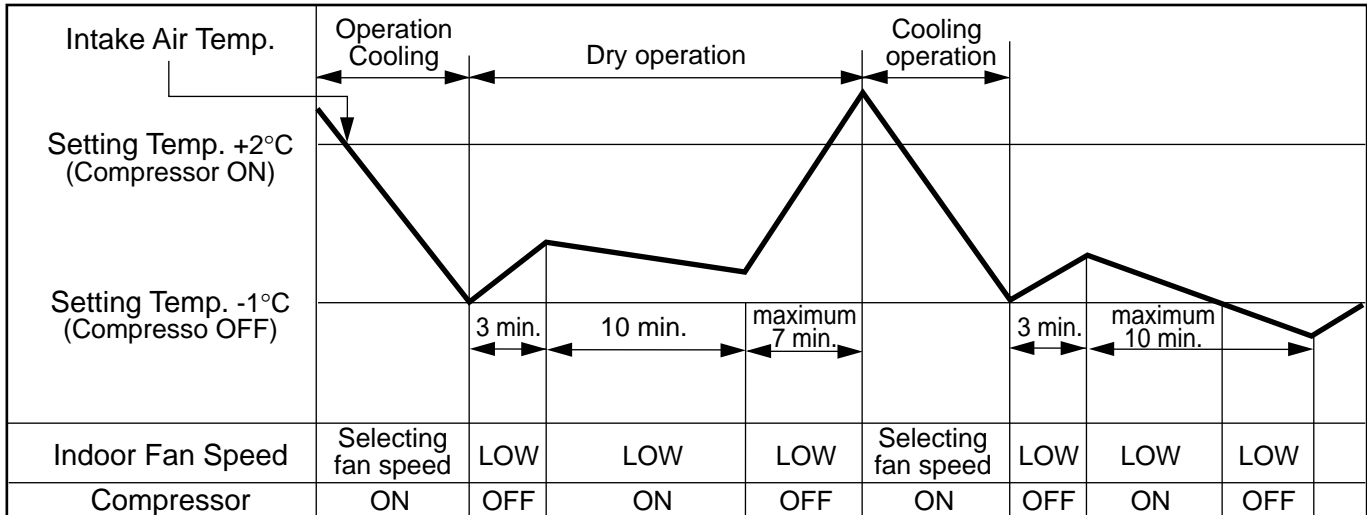

9. Protection of the evaporator pipe from frosting

- Compressor and outdoor fan stop when indoor pipe temperature is below -2°C and restart at the pipe temperature is above 12°C.

10. Air Purifying Operation(HA, ZA Model only)

Mode Selecting	Operating Mode	Fan Speed	Outdoor	OFF
Initial Starting of Air purifying Operation	- Outdoor not operating - Fan operating + Air purifying operating	- Low at the initial - But could be switched to Med. Hi	OFF	Repress Air purifying Button or ON/OFF Button
When switched to Air purifying operation	- Outdoor operating - Main Operating + Air purifying operating	Selecting Speed of Main Operating Mode	ON or OFF depend on main operating	

11. Child Lock function

This function is to operate Air conditioner only by Remocon.

The procedure is as the following

1st: Press the 2 buttons of the temperature control simultaneously, to raise-to lower on the Display Panel of the product for more 3 seconds.

2nd: The buzzer sounds and then the window of Display Panel shows α (CL) mark.

3rd: To release this function, the reverse again the operating procedure could be done.

✳ During this function is operating, any buttons of Display Panel don't work. But it is possible to operate with Remote controller.

12. Alarm mode display / only displayed while operating.

- ∅ : The sensor for sensing room temperature is open or short.
- α : The sensor for sensing piping temperature is open or short.

13. Jet Cool

- During the JET COOL function at any moment, the A/C starts to blow the cool air at extremely high speed setting the room temp. automatically to 18°C. It is especially used to cool the room temp. in the shortest time in a hot summer.
- In heat pump mode or neuro fuzzy mode however, the JET COOL function is not available.
- You can select this function during the operation of Cooling/ Soft Dry/ Auto/ Fan.
- When it is selected, JET COOL lamp is on immediately and fan speed graphic(red) is on 3 times off.
- Possible to select or cancel using JET COOL key.
- To cancel the JET COOL Mode, press the JET COOL button again or the Fan Speed button or the Room Temperature Setting button and the unit will operate in high Fan speed on Cooling mode(set up to 18°C).
- During the operation when it stops and runs again setting up is high fan speed on cooling mode(set up to 18°C).

14. Energy Saving

- ① If setting temperature of starting energy saving operation is under 22°C, first, setting temperature it up to 22°C and perform energy saving operation.
- ② After energy saving operation starts, if adaptation time of the human body pass from the point which room temperature and setting temperature meet together, increase setting temperature 1°C more.
- ③ If it doesn't satisfy number ① even in 50 minutes from the start of energy saving operation, increase 1°C.
- ④ After increasing setting temperature 1°C more by number ①, ②, perform number ②, ③ again, if setting temperature goes up to 25°C, maintain this temperature.
- ⑤ If setting temperature goes down to under 25°C, during the operation, do number ②, ③, ④ again.

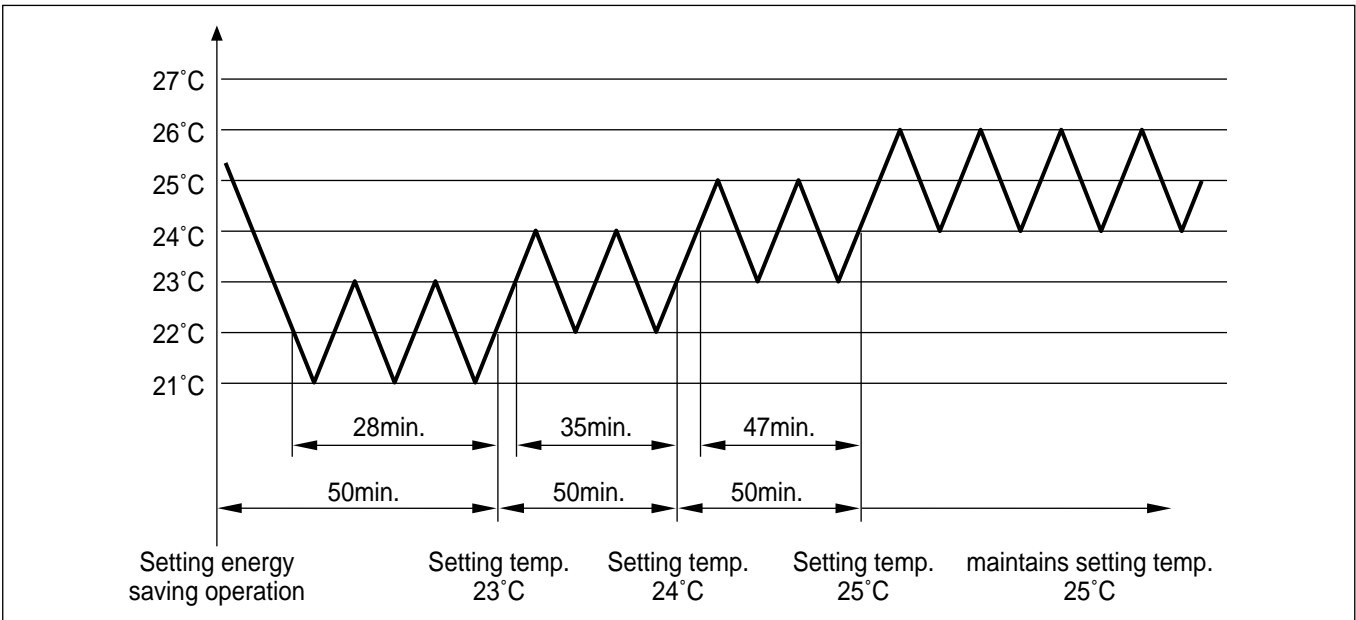

15. AUTO RESTART

In case the power comes on again after a power failure, Auto Restarting Operation is the function to operate procedures automatically to the previous operating conditions.

16. Function of changing set temperature when re-operation after stop.

Operation is set the following condition when re-operation with start/stop button.

1. Operation mode.

Cooling/soft dry mode ; Cooling mode

Heating mode ; Heating mode

2. Setting the set temperature when cooling operation.

Room temperature > Set temperature: to be set to the previous set temperature.

Room temperature ≤ Set temperature

a) Room temperature ≥ 26°C: to be set to 24°C

b) 22°C ≤ Room temperature ≤ 25°C: to be set to 21°C

c) 19°C ≤ Room temperature ≤ 21°C: to be set to -1°C less than room temperature.

d) Room temperature ≤ 18°C: to be set to 18°C

3. Setting the set temperature when heating operation.

Room temperature < Set temperature: to be set to the previous set temperature.

Room temperature ≥ Set temperature

a) Room temperature ≤ 20°C: to be set to 23°C

b) 21°C ≤ Room temperature ≤ 25°C: to be set to 26°C

c) 26°C ≤ Room temperature ≤ 28°C: to be set to +1°C more than room temperature.

d) 29°C ≤ Room temperature : to be set to 30°C

17. Function for test operation

1) Outline of Operation

- This is for checking the condition of installation during the installation, and it is operated by cooling, Fan speed is high, comp. on, and Auto air flow operations without setting temperature.

2) Operation or Cancel

- Do test operation, if you push ON/OFF button and the down room temperature checking button over 3 seconds at the same time.

- During the operation, if you push the stop button or push ON/OFF button and the down room temperature checking button over 3 seconds at the same time, the test operation will be cancelled and unit come to rest.

- During the operation, if you input remote key or key on Display panel, it performs its duties.

3) Function

- It operates cooling, fan speed is high, auto air flow operation, comp. on for 18 ± 1 minutes, regardless of room temperature.

- After 18 ± 1 minutes of operation, it becomes off itself.

- During the operation, signal 88 stands for "I_o"

Installation of Indoor, Outdoor Unit

1. Selection of the best location

1) Indoor unit

- There should not be any heat source or steam near the unit.
- There should not be any obstacles to prevent the air circulation.
- A place where air circulation in the room will be good.
- A place where drainage can be easily obtained.
- A place where noise prevention is taken into consideration.
- Do not install the unit near the door way.
- Ensure the spaces indicated by arrows from the wall, ceiling, fence, or other obstacles.

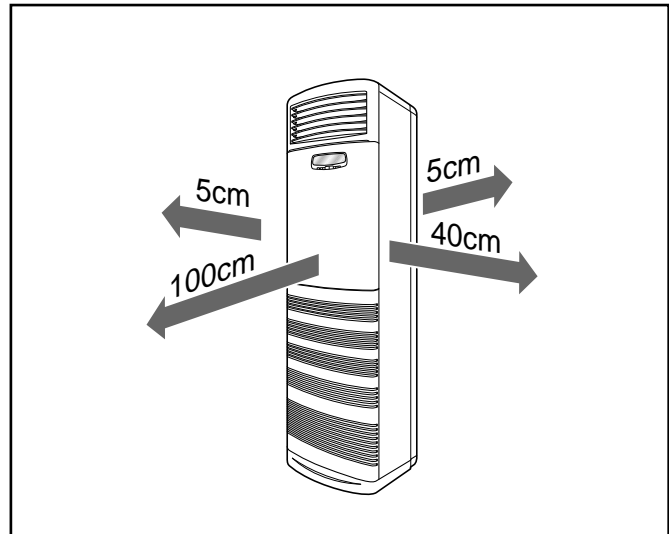

2) Outdoor unit

- If an awning is built over the unit to prevent direct sunlight or rain exposure, be careful that heat radiation from the condenser is not restricted.
- There should not be any animals or plants which could be affected by discharged hot air.
- Ensure the space indicated by arrows from the wall, ceiling, fence, or other obstacles.

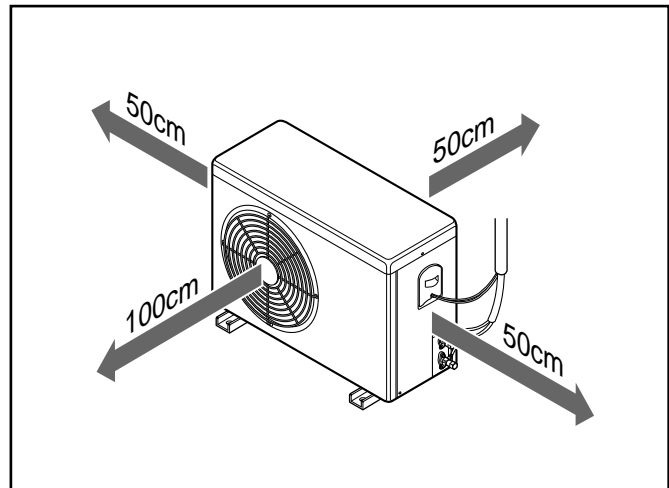

3) Piping length and the elevation

Cooling Only Model

MODEL	PIPE SIZE		Max. Length A (m)	Max. Elevation B (m)
	GAS SIDE	LIQUID SIDE		
-	5/8"	3/8"	30	20

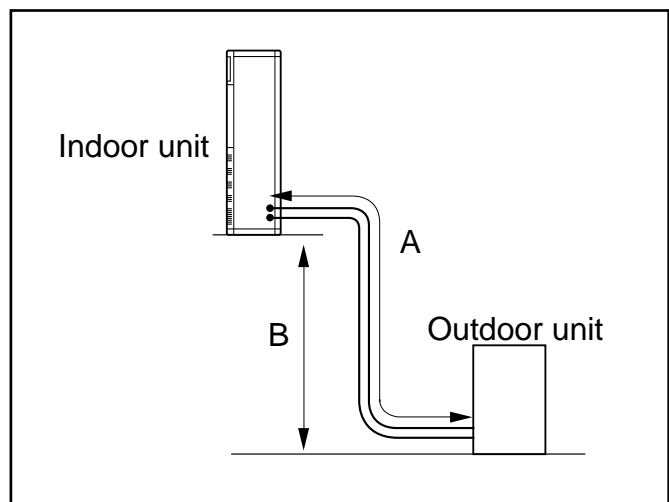

2. Indoor Unit installation

- ✎ The mounting floor should be strong and solid enough to prevent it from vibration.
- ✎ Drill the piping hole with 70mm diameter hole-core drill at either the right or the left of indoor unit. The hole should be slightly slant to the outdoor side.

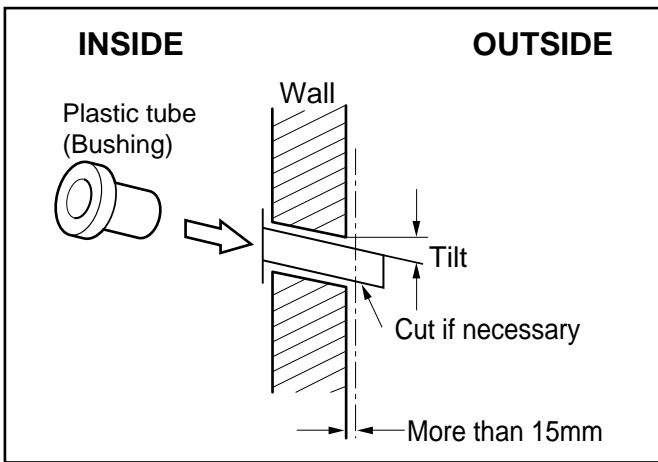
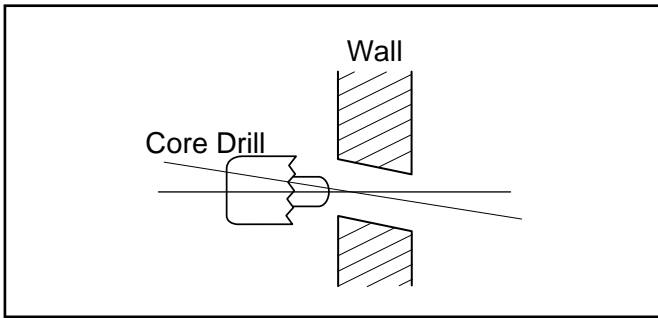
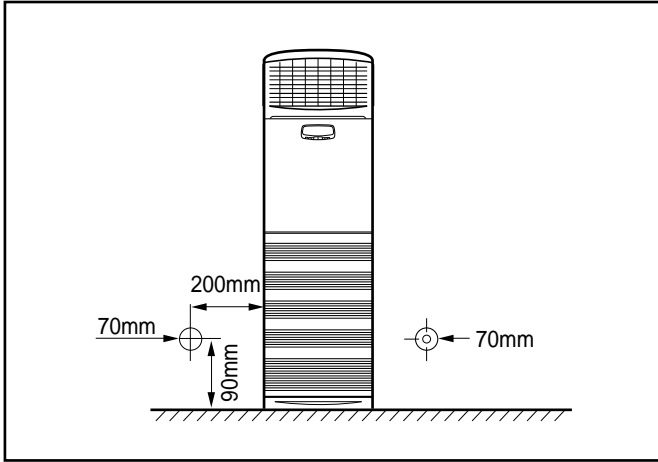

- ✎ Insert the plastic tube through the hole.
- ✎ Cut the extruded outside part of the plastic tube, if necessary.

3. Outdoor unit Installation

- ✎ Install the outdoor unit on the concrete or any solid base securely and horizontally by securing it with bolts (Ø12mm) and nuts.
- ✎ If there is any vibration transmitted to the building, mount the rubber underneath the outdoor unit.

4. Refrigerant amount

Before shipment, this air conditioner is filled with the rated amount of refrigerant including additional amount required for air-purging, subject to 5m piping length. (The rated amount of refrigerant is indicated on the name plate.) But when the piping length exceeds 5 meters, additional charge is required according to the following table.

(Unit: g)

MODEL	REFRIGERANT CHARGE
30K (BTU/h)	30 per 1m

Example)

In case of 10m long pipe(one-way), the amount of refrigerant to be replenished is:
 $(10 - 5) \times 30 = 150g$

■ Installation Method

1. Procedure

No.	Installation works	Descriptions
1	Preparation of tools and installation parts	Preparation of installation
2	Flaring the pipes	To insert the flare nuts, mounted on the connection parts of both indoor and outdoor unit, onto the copper pipes.
3	Pipe bending	To reduce the flow resistance of refrigerant.
4	Connection of installation parts (elbows, socket etc)	Connection of long piping
5	Tighten the flare nut (outdoor)	Connecting the pipings of the outdoor unit.
6	Blowing the pipings	To remove dust and scale in working.
7	Tighten the flare nut (indoor)	Connecting the pipings of the indoor unit.
8	Check a gas-leakage of the connecting part of the pipings.	
9	Air purging of the piping and indoor unit	The air which contains moisture and which remains in the refrigeration cycle may cause a malfunction on the compressor
10	Open the 3-way (liquid side) and 3-way (gas side) valves.	
11	Form the pipings	To prevent heat loss and sweat
12	Checking the drainage (indoor unit)	To ensure if water flow drain hose of indoor unit.
13	Connecting the cable between outdoor and indoor unit	Preparation of the operating
14	Connecting the main cable to outdoor unit	
15	Supply the power to the crankcase heater (Before the operating the unit)	To prevent the liquid back to the compressor. (Heat pump only)
16	Cooling operation, Heating operation (Use the remote control or display of the indoor unit)	

2. Preparation of installation parts and tools

No.	Installation Parts, Tools	Use
1	Flaring tool (Ø 6,35 - Ø 19,05)	Flaring the pipes
2	Remear	Remove burrs from cut edges of pipes.
3	Pipe cutter (MAX 35mm Copper pipe)	Cutting the pipings
4	Wrench (H5, H4 hexagonal wrench)	To open the service valve
5	Pipe bender	Bending the pipings
6	Leak detector	Check a gas-leakage of connecting part of the pipings
7	Manifold gauge	To measure the pressure, to charge the refrigerant
8	Charge-nipple	To connect the bombe
9	Vacuum pump	To remove the air in the pipe.
10	Charge cylinder balance	To measure the refrigerant amount
11	Bombe (Freon-22)	Gas charge Air purge Cleaning the pipe
12	Spanner	To tighten the connecting parts of the pipings
13	Monkey spanner	
14	Driver(⊕, ⊖)	
15	Benchi (150mm)	Cutting the wires
16	Tapeline	To measure the length
17	Core drill	To make holes through the concrete wall and blocks
18	Voltmeter, Amperemeter, Clampmeter	To measure the current and voltage
19	Insulation resistance tester	To measure the insulation resistance
20	Glass thermometer	To measure the intake and outlet air temperature of the indoor unit
21	Copper tubes	To use the connecting pipings
22	Insulation material	To cover the connecting pipings
23	Tape	To finish the connecting pipings
24	Electrical Leakage Breaker	To shut off the main power
25	Cable	To connect the cable from outdoor unit to indoor unit
26	Drain hose sockets, elbows	To remote the condensing water

■ Piping of Indoor Unit

1. Preparation of piping

- **Cut the pipes and the cable**
 - Use the accessory piping kit or the pipes purchased locally.
 - Measure the distance between the indoor and the outdoor unit.
 - Cut the pipes a little longer than measured distance.
 - Cut the cable 1.5m longer than the pipe length.

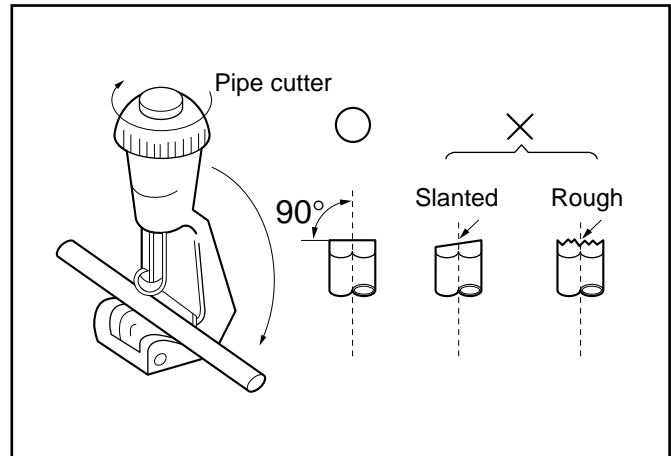

- **Remove burrs.**
 - Remove burrs from cut edges of pipes.
 - Turn the pipe end down to avoid the metal powder entering the pipe.

Caution:

If burrs are not removed, they may cause a gas leakage.

- **Flaring the pipes.**
 - Insert the flare nuts, mounted on the connection ports of both indoor and outdoor unit, onto the copper pipes. Some refrigerant gas may leak, when the flare nuts are removed from the indoor unit, as some gas is charged to prevent the inside of the pipe from rusting.
 - Fit the copper pipe end into the Bar of flare tool about 0~0.5mm higher. (See illustration)
 - Flare the pipe ends.

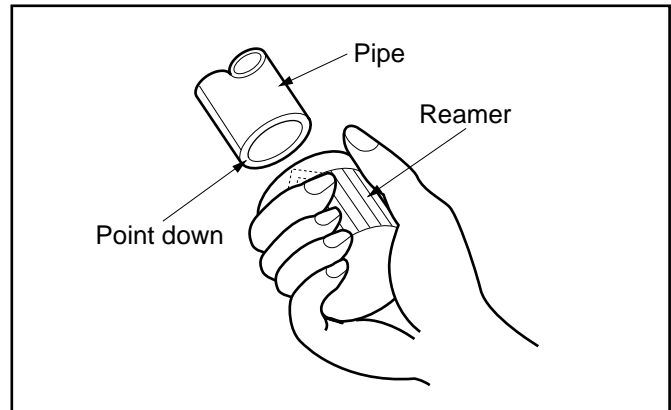

- **Tape the flaring part to protect it from dust or damages.**

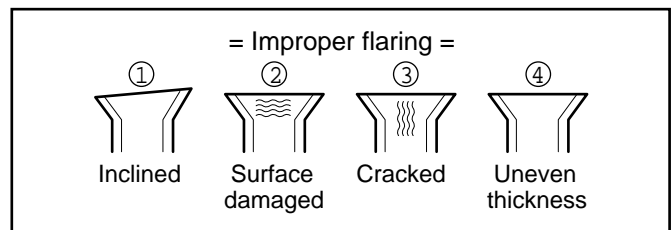
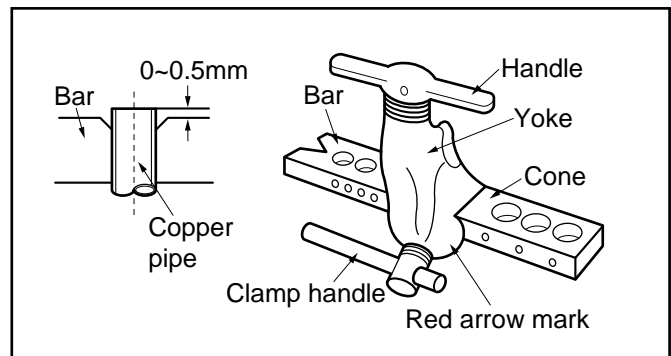

2. Connection of piping

- Move the indoor tubing and drain hose to the hole
 - Remove tubing holder and pull the tubing out of the chassis.
- Replace the tubing holder into original position
- Route the tubing and the drain hose straight backwards.
- Insert the connecting cable into the indoor unit through the hole.
 - Do not connect the cable to the indoor unit
 - Make a small loop with the cable for easy connection later.
- Tape the tubing and the connecting cable.
- Indoor unit installation.
- Connecting the pipings to the indoor unit.

- Align the center of the pipings and sufficiently tighten the flare nut with fingers.
- Finally, tighten the flare nut with torque wrench until the wrench clicks. When tightening the flare nut with torque wrench, ensure the direction for tightening follows the arrow on the wrench.

PIPE SIZE	TORQUE
3/8"	4.2 Kg·m
1/2"	5.5 Kg·m
5/8"	5.5 Kg·m
3/4"	6.5 Kg·m

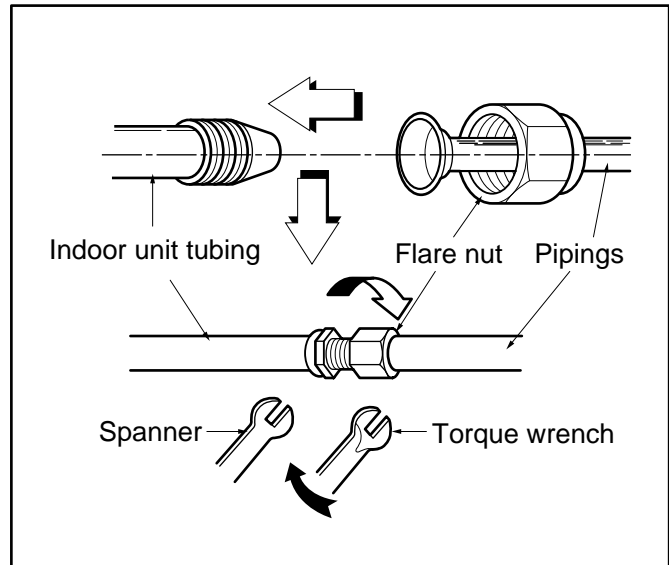

3. Precautions in bending

- If it is necessary to bend or stretch the tubing, use the spring which is attached to the tubing in stead of pipe bender.
 - Please make a careful notice to make a smooth line.
 - Hold the tubing with your two hands closely and then bend or stretch it slowly not to make any crack.
 - Remember that the radius (R) should not exceed 70mm (Refer to Fig. 1)
- Do not repeat the bending process to prevent the tubing from cracking or crushing.
- Keep in mind that the bending part should not be cracked and make the radius (R) as long as possible (Refer to Fig. 2)

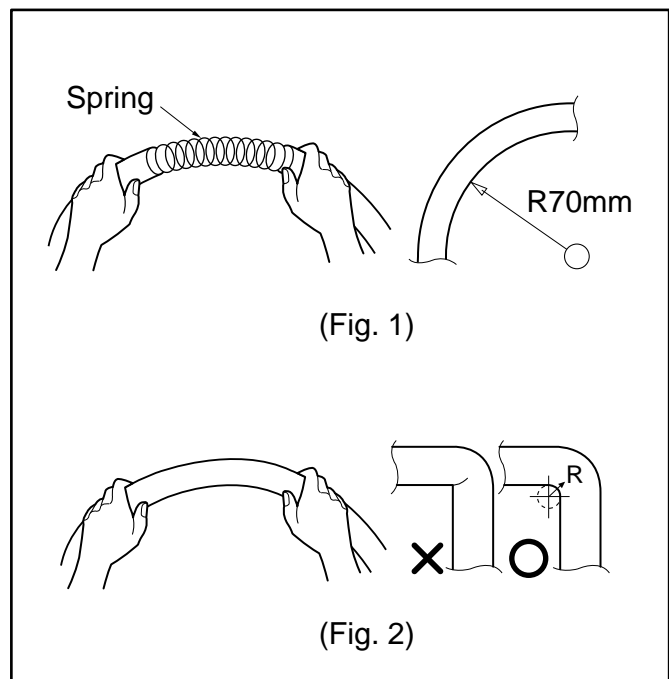

■ Connecting the Cable to Indoor Unit

- In order to protect cable, it should be inserted "Bushing Rubber".
- The inside and outside connecting cable can be connected after opening the inlet grille.

□ Open the inlet grille manually.

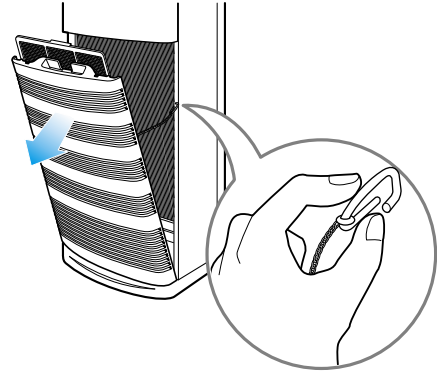

□ Connect the supplied cables to the connector on the control board.

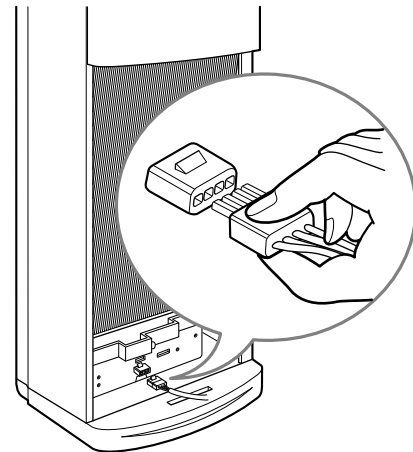

□ Close the inlet grille.

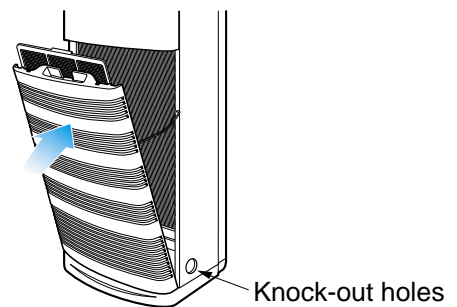

■ Connecting Piping and the Cable to Outdoor Unit

1) Connecting pipings to outdoor unit

- Align the center of the pipings and sufficiently tighten the flare nut with fingers.
- Finally tighten the flare nut with torque wrench until the wrench clicks.
 - When tightening the flare nut with torque wrench, ensure the direction for tightening follows the arrow on the wrench.

PIPE SIZE	TORQUE
3/8"	4.2 Kg·m
1/2"	5.5 Kg·m
5/8"	5.5 Kg·m
3/4"	6.5 Kg·m

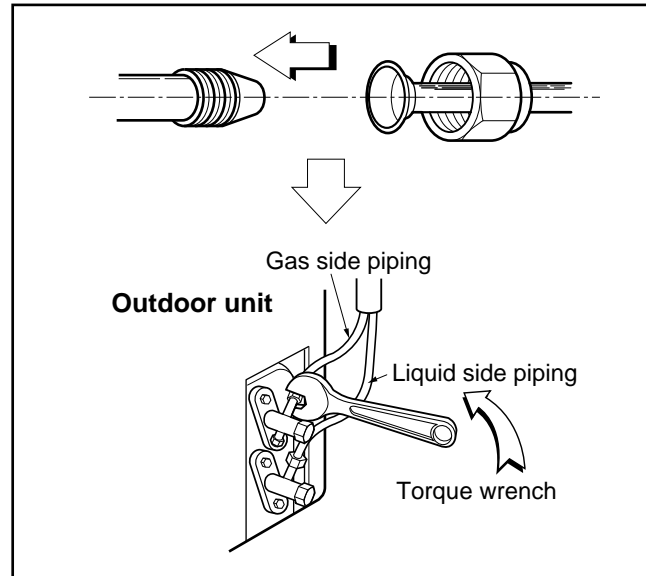

2) Connecting cable to outdoor unit

- Open the control board cover from the outdoor unit by removing the screws.
- Connect wires to the terminals on the control board individually and secure the cables onto the control board with clamp.

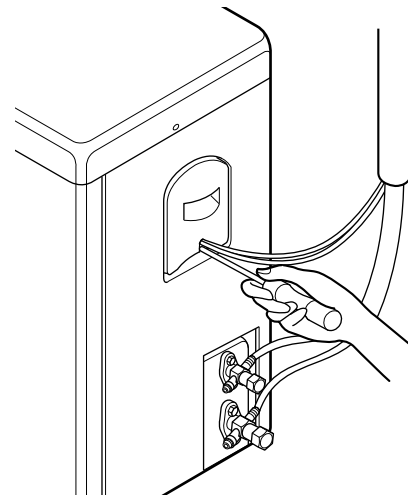

⚠ CAUTION

Perform grounding

- This product should be grounded.
- Defective grounding could cause an electric shock.

■ Power Supply and Wiring

The unit is completely wired internally at the factory according to general rule of electrical technology, but local rules, if they are required, should be complied with.

1. Power supply

Power source must fulfill the following conditions:

- **The working voltage should be higher than 90% and lower than 110% of the rated voltage marked on the name plate.**
- **The starting voltage should be higher than 85% of the rated voltage marked on the name plate.**

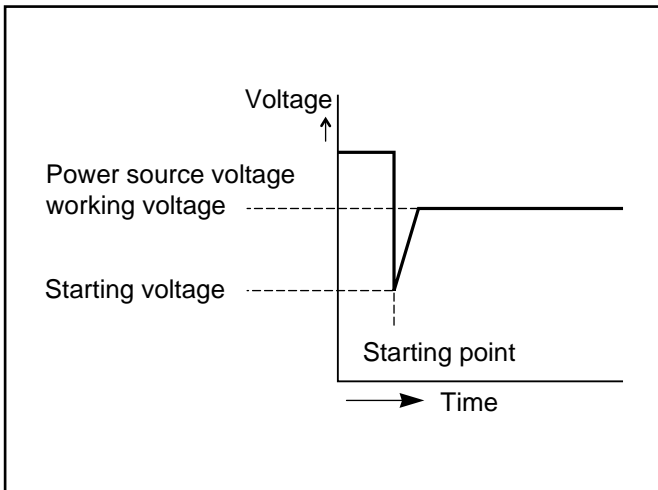

2. Wiring

After the confirmation of the above conditions, prepare the wiring as follows:

- **Use the power supply cord(Rubber insulation, type Ho7RNF approved by HAR or SAA) suitable for the product's electrical capacity.**

UNIT		VOLTS	Conductor cross-sectional area	Outside diameter
30K	H/P	450/750V	4.0mm ²	13.3mm
	C/O	450/750V	2.5mm ²	11.8mm

- **Provide a recognized circuit breaker as below between power source and unit.
A disconnection device to adequately disconnect all supply lines must be fitted.
(for service operations)**

UNIT		Circuit breaker capacity
30K	H/P	30A
	C/O	30A

- **The screws which fasten the wiring in the casing of electrical fittings are liable to come loose from vibrations to which the unit is subjected during the course of transportation. Check them and make sure that they are all tightly fastened.
(If they are loose, it could give rise to burn-out of the wires.)**
- **See to it that the starting voltage is maintained at more than 90 percent of the rated voltage marked on the name plate.**
- **The following troubles would be caused by voltage drop-down.
Vibration of a magnetic switch, damage on the contact point there of, fuse breaking, disturbance to the normal function of a overload protection device.**

■ Checking the Drainage and Form the Piping

1. Checking the Drainage

- Remove the inlet grille with your hands as shown (right and left) and pull in the direction indicated by the arrow.

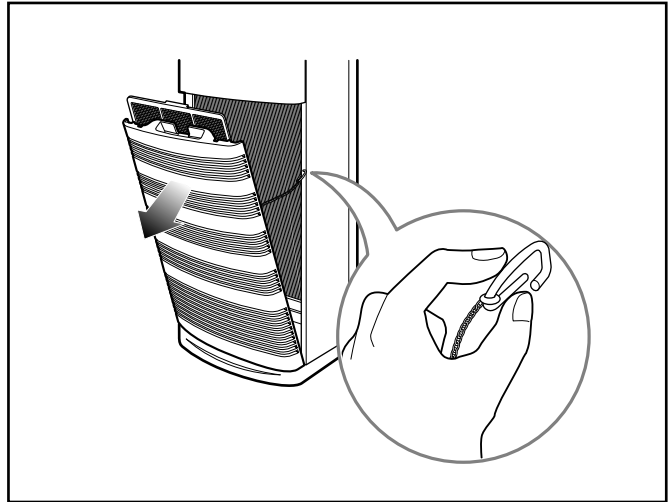

□☑ Check the drainage

- Pour a glass of water into the drain pan.
- Ensure if water flows drain hose of indoor unit.

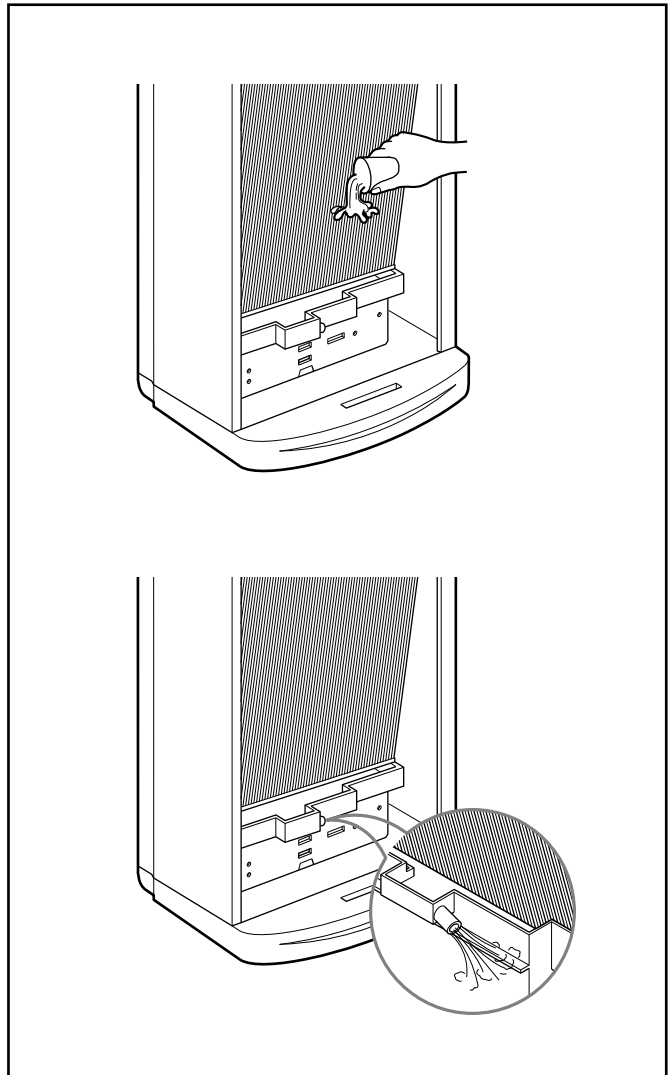

2. Form the Piping

- Wrap the connecting port of indoor unit with the insulation material and secure it with two Plastic Bands. (for the right Piping)
 - If you connect an additional drain hose, the end of the drain-outlet should be water, and fix it on the wall to avoid swinging in the wind.)

In case the outdoor unit is installed below position of the indoor unit.

- ⊥ Tape the Piping, and Connecting Cable from down to up.
- ∅ From the piping gathered by taping along the exterior wall fix it on the wall by saddle or equivalent.

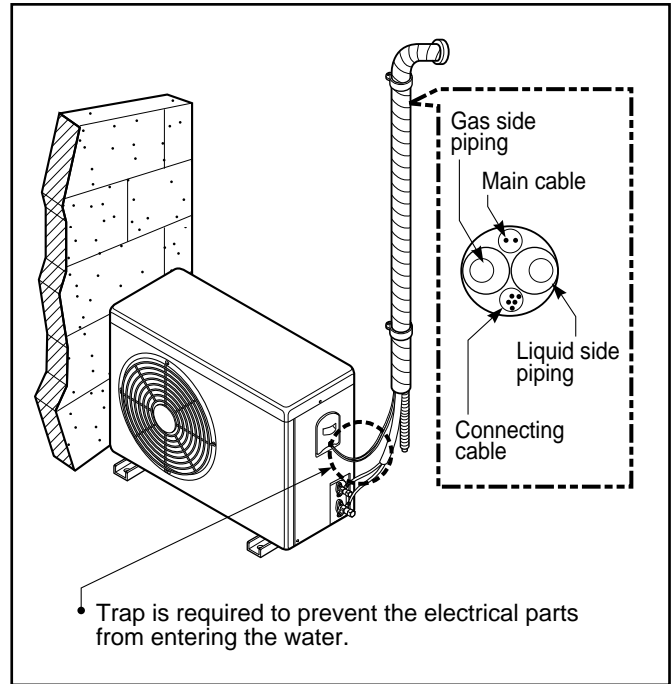

In case the outdoor unit is installed upper position of the indoor unit.

- Tape the piping and connecting cable from down to up.
- ⊥ In order to prevent water from entering the room, tape the piping from a trap.
- ∅ Fix the piping onto the wall with saddle or bracket.

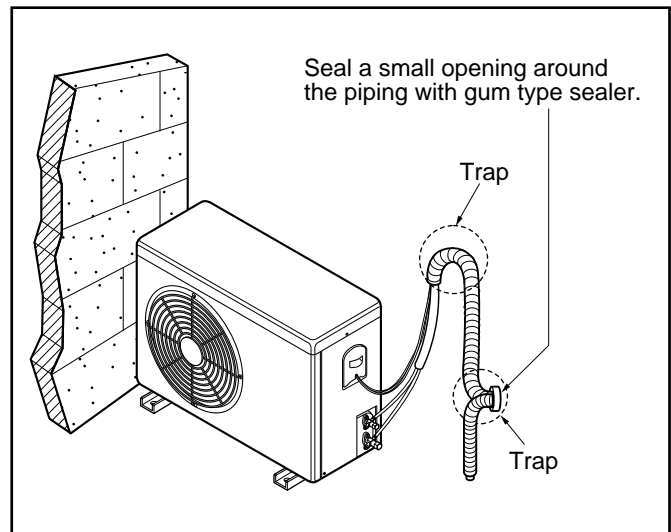

Drain water treatment of outdoor Unit(Heat Pump Only)

- When using the drain elbow hose, use a mount of 3cm of higher.
- ⊥ In the cold district (0°C continued for 2~3 days), the drain water is frozen and the fan fails to function, do not use the drain elbow.

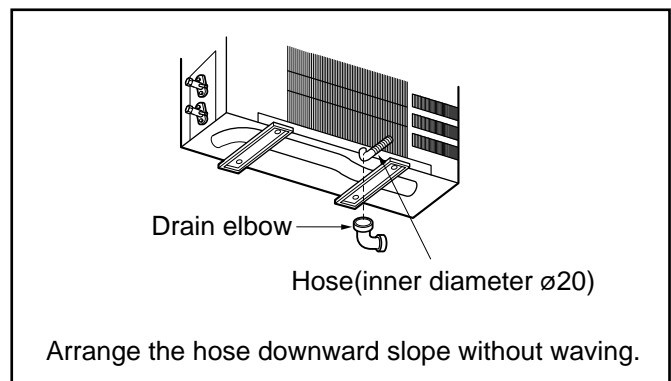

Test running

1. PRECAUTIONS IN TEST RUN

- The initial power supply must provide at least 90% of the rated voltage. Otherwise, the air conditioner should not be operated.

Caution

Carry out the test run more than 5 minutes without fail.
(Test run will be cancelled 18 minutes later automatically)

- The test run is started by pressing the down room temperature checking button and ON/OFF button for 3 seconds at the same time.
- To cancel the test run, press ON/OFF button.

CHECK THE FOLLOWING ITEMS WHEN INSTALLATION IS COMPLETE

- After completing work, be sure to measure and record trial run properties, and store measured data, etc.
- Measuring items are room temperature, outside temperature, suction temperature, blow out temperature, wind velocity, wind volume, voltage, current, presence of abnormal vibration and noise, operating pressure, piping temperature, compressive pressure.
- As to the structure and appearance, check following items.

- ┆ Is the circulation of air adequate?
- ┆ Is the draining smooth?
- ┆ Is the heat insulation complete (refrigerant and drain piping)?
- ┆ Is there any leakage of refrigerant?

- ┆ Is the remote controller switch operated?
- ┆ Is there any faulty wiring?
- ┆ Are not terminal screws loosened?

M4...118N·cm{12kgf·cm} M5...196N·cm{20kgf·cm}
M6...245N·cm{25kgf·cm} M8...588N·cm{60kgf·cm}

2. Connection of power supply

1. Connect the power supply cord to the independent power supply.

- Circuit breaker is required.

2. Operate the unit for fifteen minutes or more.

3. Evaluation of the performance

1. Measure the temperature of the intake and discharge air.
2. Ensure the difference between the intake temperature and the discharge one is more than 8°C (Cooling) or reversely (Heating).

CAUTION

After the confirmation of the above conditions, prepare the wiring as follows:

- 1) **Never fail to have an individual power specialized for the air conditioner. As for the method of wiring, be guided by the circuit diagram pasted on the inside of control box cover.**
- 2) **Provide a circuit breaker switch between power source and the unit.**
- 3) **The screw which fasten the wiring in the casing of electrical fittings are liable to come loose from vibrations to which the unit is subjected during the course of transportation. Check them and make sure that they are all tightly fastened. (If they are loose, it could give rise to burn-out of the wires.)**
- 4) **Specification of power source**
- 5) **Confirm that electrical capacity is sufficient.**
- 6) **Be sure that the starting voltage is maintained at more than 90 percent of the rated voltage marked on the name plate.**
- 7) **Confirm that the cable thickness is as specified in the power sources specification. (Particularly note the relation between cable length and thickness.)**
- 8) **Never fail to equip a leakage breaker where it is wet or moist.**
- 9) **The following troubles would be caused by voltage drop-down.**
 - Vibration of a magnetic switch, damage on the contact point there of, fuse breaking, disturbance to the normal function of a overload protection device.
 - Proper starting power is not given to the compressor.

HAND OVER

Teach the customer the operation and maintenance procedures, using the operation manual (air filter cleaning, temperature control, etc.).

3-way Valve

1. Pump down

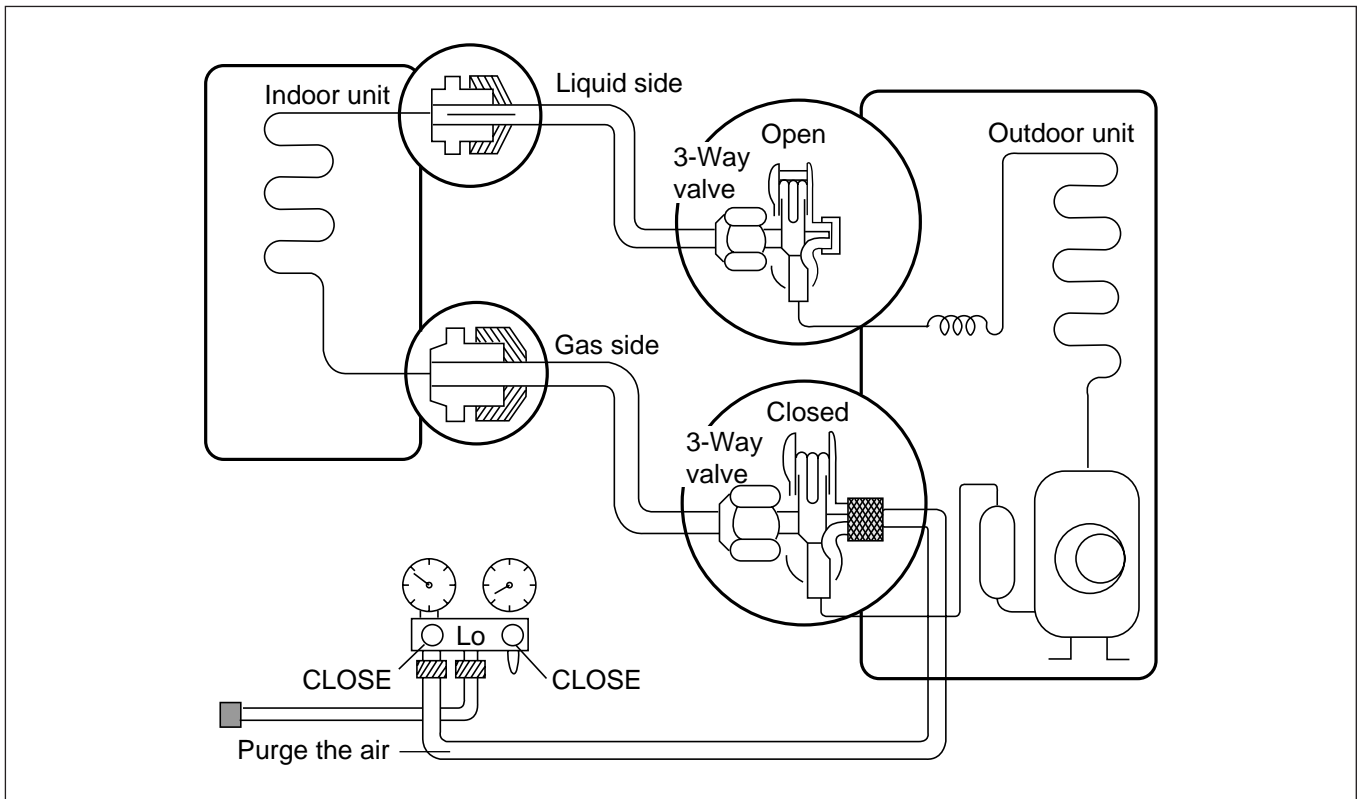

• Procedure

(1) Confirm that both liquid side and gas side valves are set to the open position.

- Remove the valve stem caps and confirm that the valve stems are in the raised position.
- Be sure to use a hexagonal wrench to operate the valve stems.

(2) Operate the unit for 10 to 15 minutes.

(3) Stop operation and wait for 3 minutes, then connect the charge set to the service port of the 3-way valve.

- Connect the charge hose to the service port.

(4) Air purging of the charge hose.

- Open the low-pressure valve on the charge set slightly to air purge from the charge hose.

(5) Set the liquid side valve to the closed position.

(6) Operate the air conditioner in cooling mode and stop it when the gauge indicates 1kg/cm²g.

(7) Immediately set the 3-way valve to the closed position.

- Do this quickly so that the gauge ends up indicating 3 to 5kg/cm²g.

(8) Disconnect the charge set, and mount the 2-way and 3-way valve's stem nuts and the service port nut.

- Use torque wrench to tighten the service port nut to a torque of 1.8 kg.m.
- Be sure to check for gas leakage.

1) Re-airpurging (Re-installation)

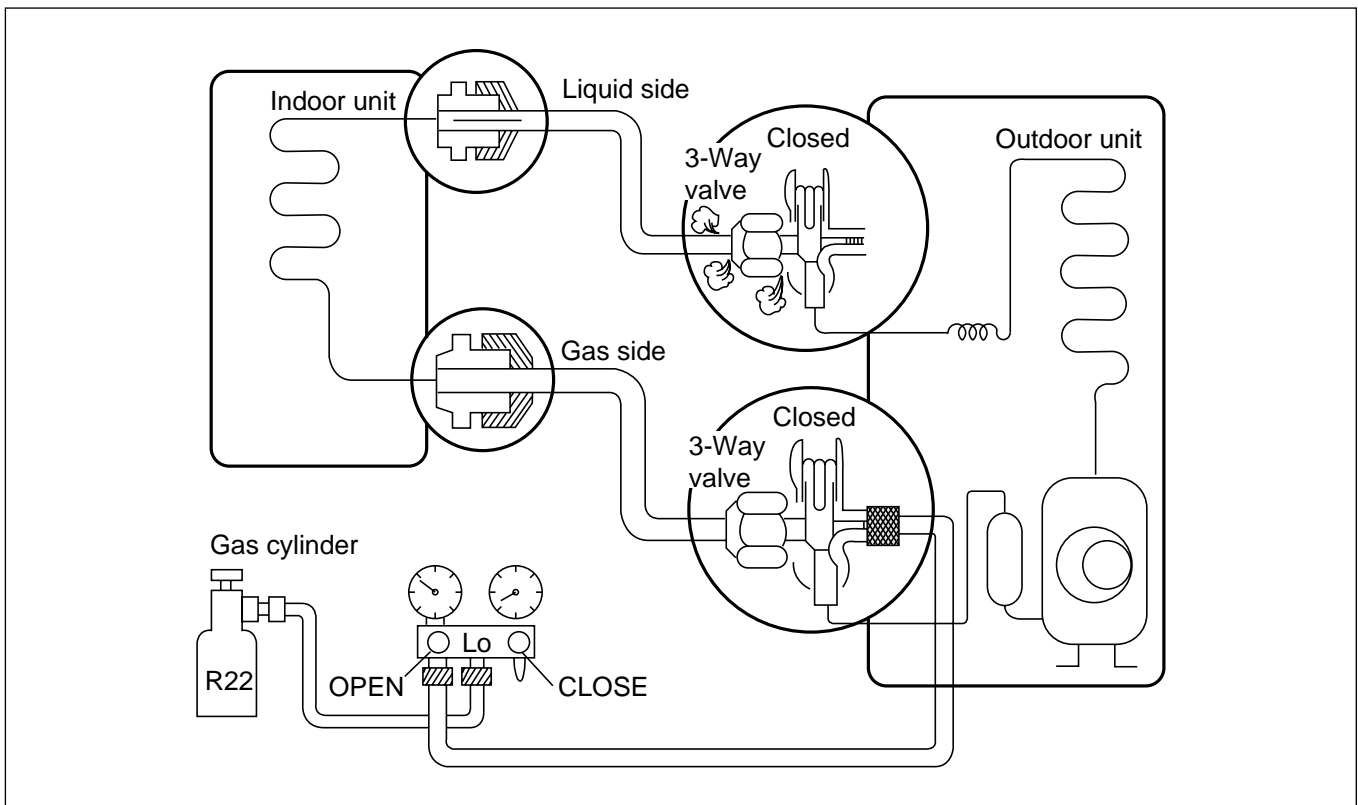

• Procedure

- (1) **Confirm that both the liquid side valve and the gas side valve are set to the closed position.**
- (2) **Connect the charge set and a gas cylinder to the service port of the 3-way valve.**
 - Leave the valve on the gas cylinder closed.
- (3) **Air purging.**
 - Open the valves on the gas cylinder and the charge set. Purge the air by loosening the flare nut on the liquid side valve approximately 45° for 3 seconds then closing it for 1 minute; repeat 3 times.
 - After purging the air, use a torque wrench to tighten the flare nut on liquid side valve.
- (4) **Check for gas leakage.**
 - Check the flare connections for gas leakage.
- (5) **Discharge the refrigerant.**
 - Close the valve on the gas cylinder and discharge the refrigerant until the gauge indicates 3 to 5 kg/cm²g.
- (6) **Disconnect the charge set and the gas cylinder, and set the 2-way and 3-way valves to the open position.**
 - Be sure to use a hexagonal wrench to operate the valve stems.
- (7) **Mount the valve stem nuts and the service port nut.**
 - Use torque wrench to tighten the service port nut to a torque of 1.8 kg.m.
 - Be sure to check for gas leakage.

*** CAUTION:**
Do not leak the gas in the air during Air Purging.

2) Balance refrigerant of the 3-way valve

(Gas leakage)

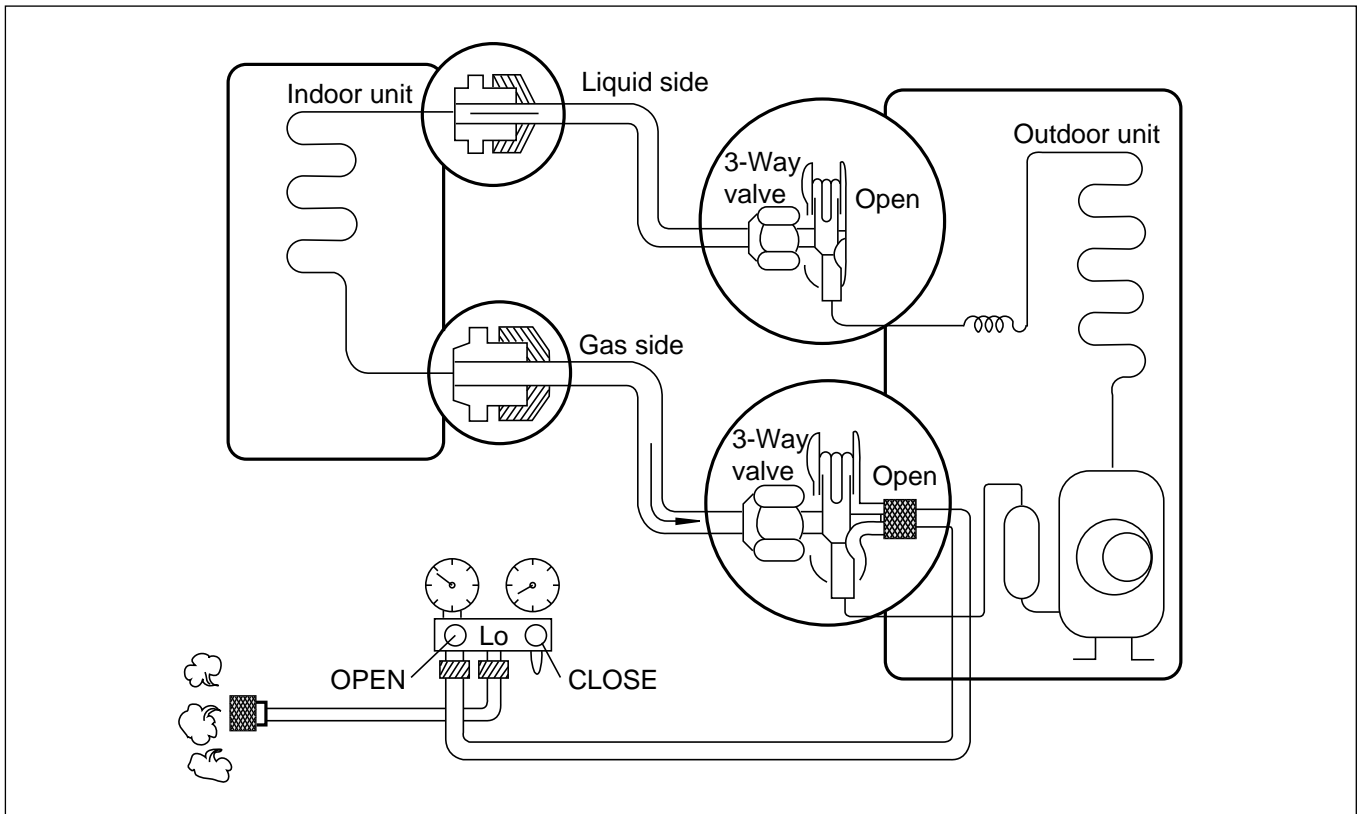

• Procedure

- (1) Confirm that both the liquid side and gas side valves are set to the back seat.
- (2) Connect the charge set to the 3-way valve's port.
 - Leave the valve on the charge set closed.
 - Connect the charge hose to the service port.
- (3) Open the valve (Lo side) on the charge set and discharge the refrigerant until the gauge indicates 0 kg/cm²G.
 - If there is no air in the refrigerant cycle (the pressure when the air conditioner is not running is higher than 1 kg/cm²G), discharge the refrigerant until the gauge indicates 0.5 to 1 kg/cm²G. if this is the case, it will not be necessary to apply a evacuation.
 - Discharge the refrigerant gradually; if it is discharged too suddenly, the refrigeration oil will also be discharged.

2. Evacuation

(All amount of refrigerant leaked)

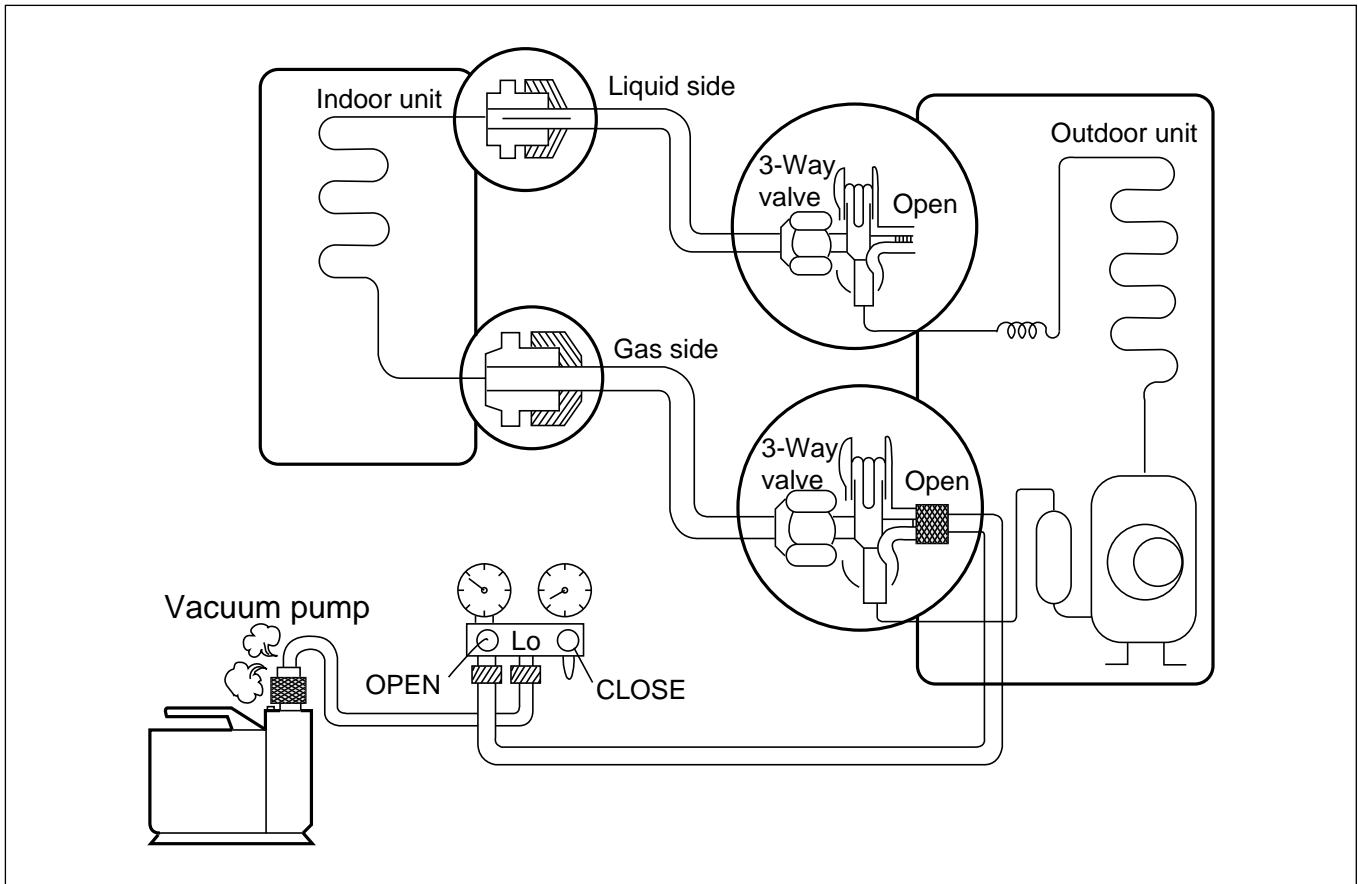

• Procedure

- (1) Connect the vacuum pump to the center hose of charge set center hose
- (2) Evacuation for approximately one hour.
 - Confirm that the gauge needle has moved toward -76 cmHg (vacuum of 4 mmHg or less).
- (3) Close the valve (Lo side) on the charge set, turn off the vacuum pump, and confirm that the gauge needle does not move (approximately 5 minutes after turning off the vacuum pump).
- (4) Disconnect the charge hose from the vacuum pump.
 - Vacuum pump oil.
If the vacuum pump oil becomes dirty or depleted, replenish as needed.

3. Gas Charging

(After Evacuation)

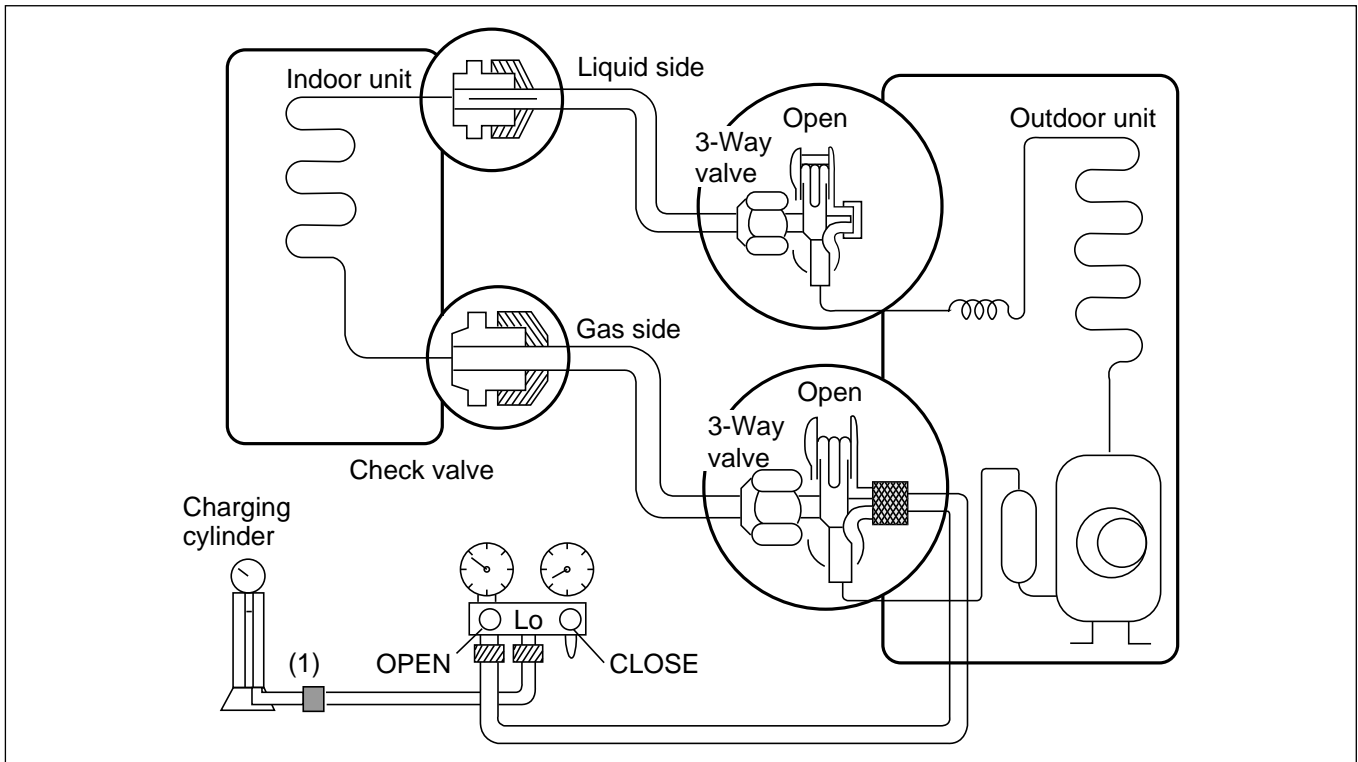

• Procedure

(1) Connect the charge hose to the charging cylinder.

- Connect the charge hose which you disconnected from the vacuum pump to the valve at the bottom of the cylinder.
- If you are using a gas cylinder, also use a scale and reverse the cylinder so that the system can be charged with liquid.

(2) Purge the air from the charge hose.

- Open the valve at the bottom of the cylinder and press the check valve on the charge set to purge the air. (Be careful of the liquid refrigerant). The procedure is the same if using a gas cylinder.

(3) Open the valve (Lo side on the charge set and charge the system with liquid refrigerant.

- If the system can not be charged with the specified amount of refrigerant, it can be charged with a little at a time (approximately 150g each time) while operating the air conditioner in the cooling cycle; however, one time is not sufficient, wait approximately 1 minute and then repeat the procedure (pumping down-pin).

This is different from previous procedures.

Because you are charging with liquid refrigerant from the gas side, absolutely do not attempt to charge with larger amounts of liquid refrigerant while operating the air conditioner.

(4) Immediately disconnect the charge hose from the 3-way valve's service port.

- Stopping partway will allow the gas to be discharged.
- If the system has been charged with liquid refrigerant while operating the air conditioner turn off the air conditioner before disconnecting the hose.

(5) Mount the valve stem nuts and the service port nut.

- Use torque wrench to tighten the service port nut to a torque of 1.8 kg.m.
- Be sure to check for gas leakage.

2) Heating Mode (After Evacuation)

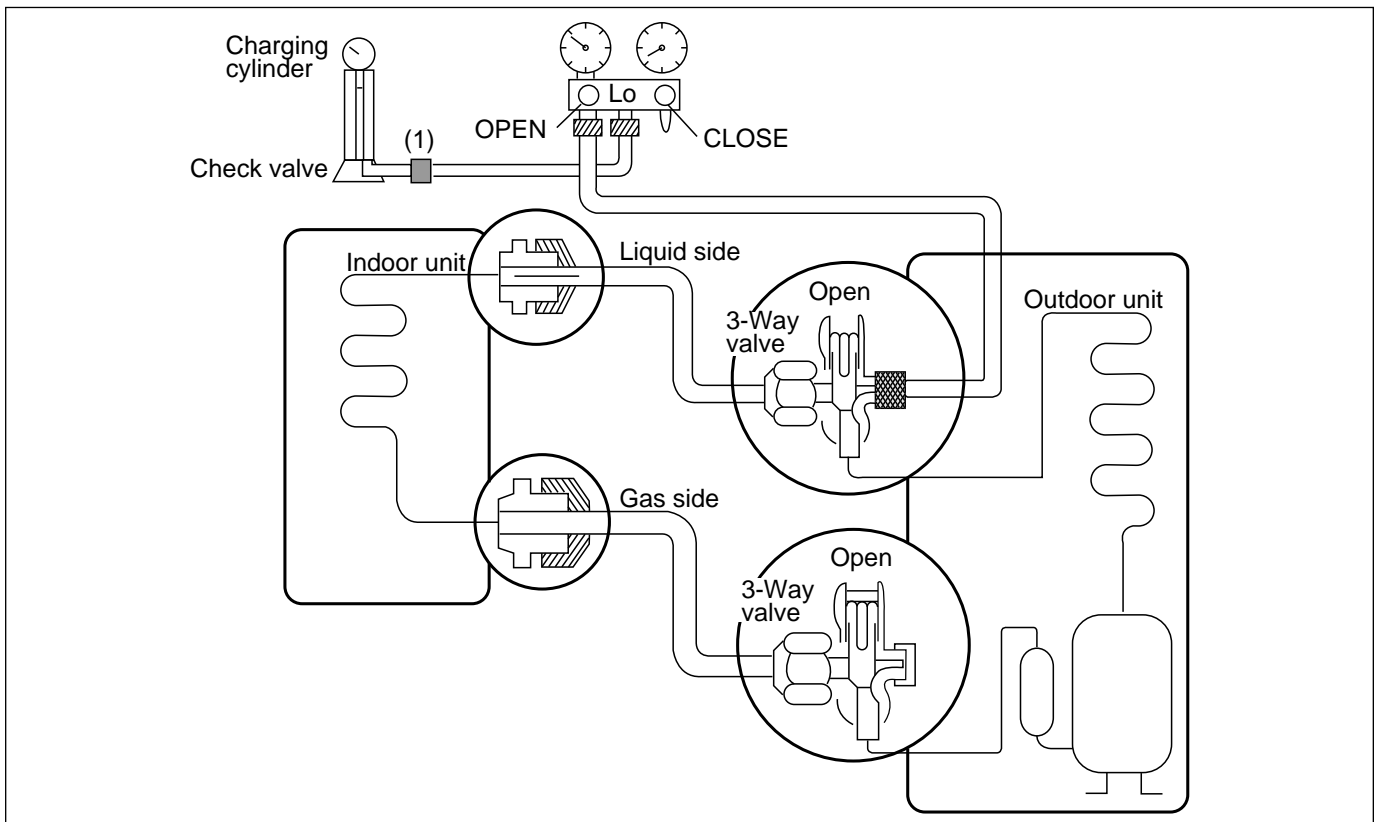

• Procedure

(1) Connect the charge hose to the charge cylinder.

- Connect the charge hose which you disconnected from the vacuum pump to the valve at the bottom of the cylinder.
- If you are using a gas cylinder, use a scale and reverse the cylinder so that the system can be charged with liquid.

(2) Purge the air from the charge hose.

- Open the valve at the bottom of the cylinder and press the check valve on the charge set to purge the air. (Be careful of the liquid refrigerant). The procedure is the same if using a gas cylinder.

(3) Open the valve (Lo side) on the charge set and charge the system with liquid refrigerant.

- If the system can not be charged with the specified amount of refrigerant, it can be charged with a little at a time (approximately 150g each time) while operating the air conditioner in the cooling cycle; however, one time is not sufficient, wait approximately 1 minute and then repeat the procedure (pumping down-pin).

This is different from previous procedures. Because you are charging with liquid refrigerant from the gas side, absolutely do not attempt to charge with larger amounts of liquid refrigerant while operating the air conditioner.

(4) Immediately disconnect the charge hose from the 3-way valve's service port.

- Stopping partway will allow the gas to be discharged.
- If the system has been charged with liquid refrigerant while operating the air conditioner turn off the air conditioner before disconnecting the hose.

(5) Mount the valve stem nuts and the service port nut.

- Use a torque wrench to tighten the service port nut.
- Be sure to check gas leakage.

Cycle Troubleshooting Guide

Trouble analysis

1. Check temperature difference between intake and discharge air and operating current.

	Temp. difference : approx. 0°C Current : less than 80% of rated current	All amount of refrigerant leaked out Check refrigeration cycle
Temp. Difference	Temp. difference : approx. 8°C Current : less than 80% of rated current	Refrigerant leakage Clog of refrigeration cycle Defective compressor
Operating Current	Temp. difference : less than 8°C Current : over the rated current	Excessive amount of refrigerant
	Temp. difference : over 8°C	Normal

Notice :

Temperature difference between intake and discharge air depends on room air humidity. When the room air humidity is relatively higher, temperature difference is smaller. When the room air humidity is relatively lower temperature difference is larger.

2. Check temperature and pressure of refrigeration cycle.

Suction pressure (Compared with the normal value)	Temperature (Compared with the normal value)	Cause of Trouble	Description
Higher	High	Defective compressor Defective 4-way reverse valve	Current is low
	Normal	Excessive amount of refrigerant	High pressure does not quickly rise at the beginning of operation
Lower	Higher	Insufficient amount of refrigerant (Leakage) Clogging	Current is low Current is low

Notice :

1. The suction pressure is usually 4.5~6.0 kg/cm²G at normal condition.
2. The temperature can be measured by attaching the thermometer to the low pressure tubing and wrap it with putty.

Electronic Parts Troubleshooting Guide

1) No Cooling operation performed

Possible Trouble 1 : The unit does not operate.

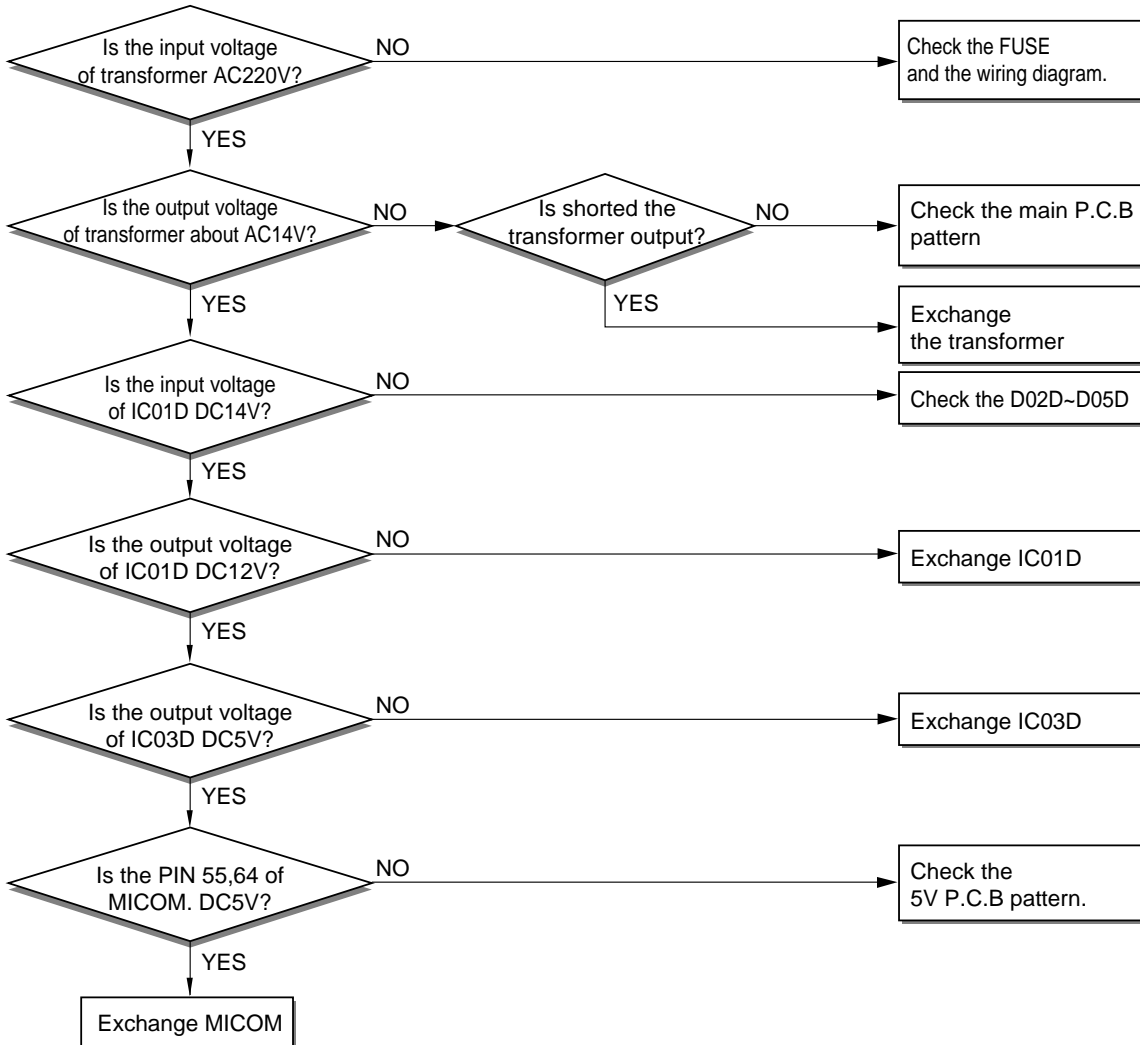

Possible Trouble 2 : The indoor fan does not operate.

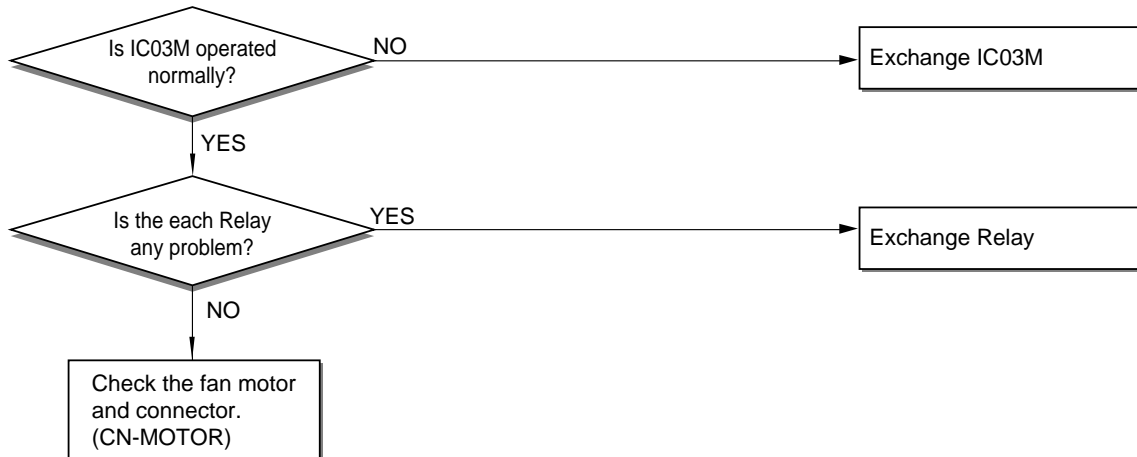

2) No heating operation works

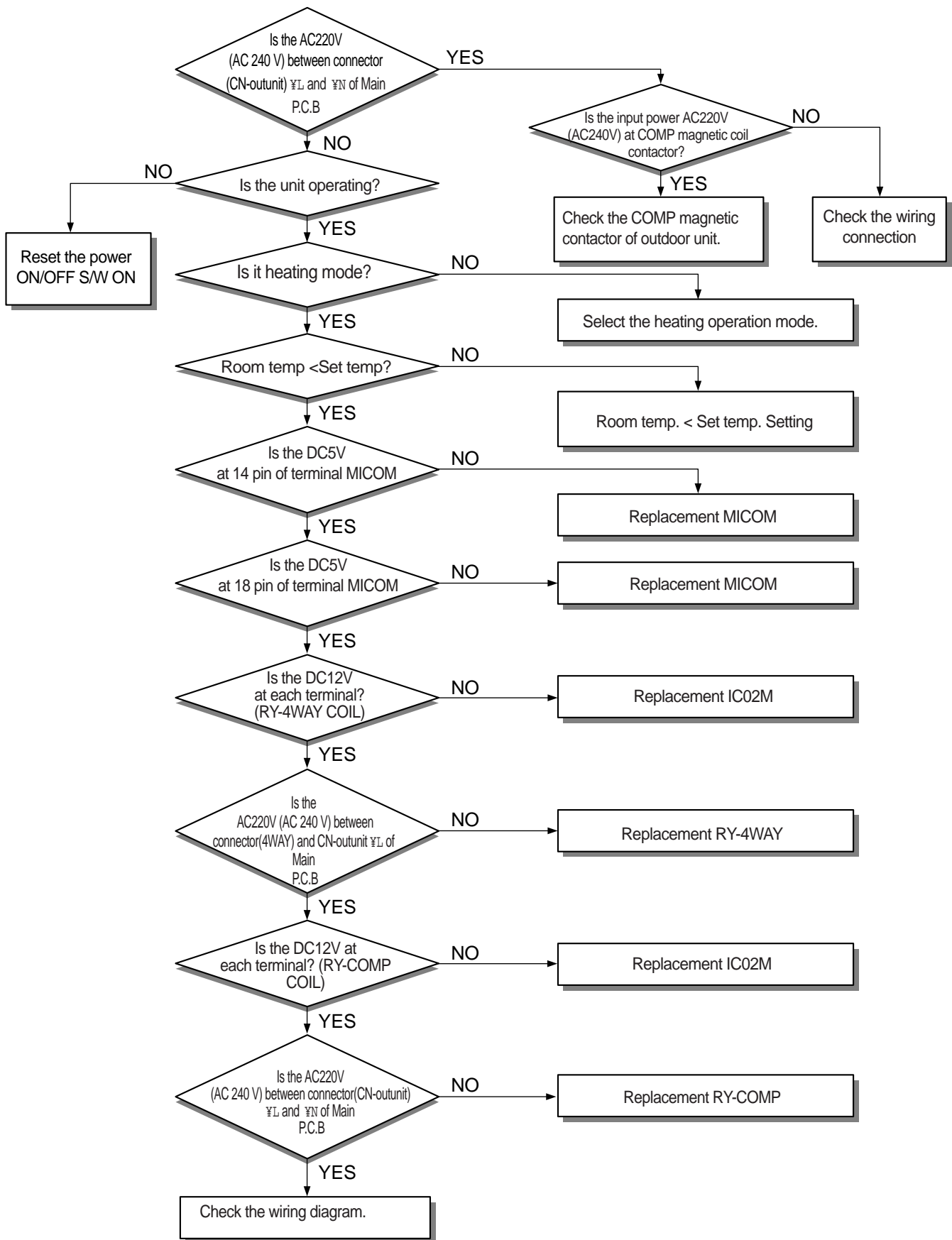

3) No heater operation works

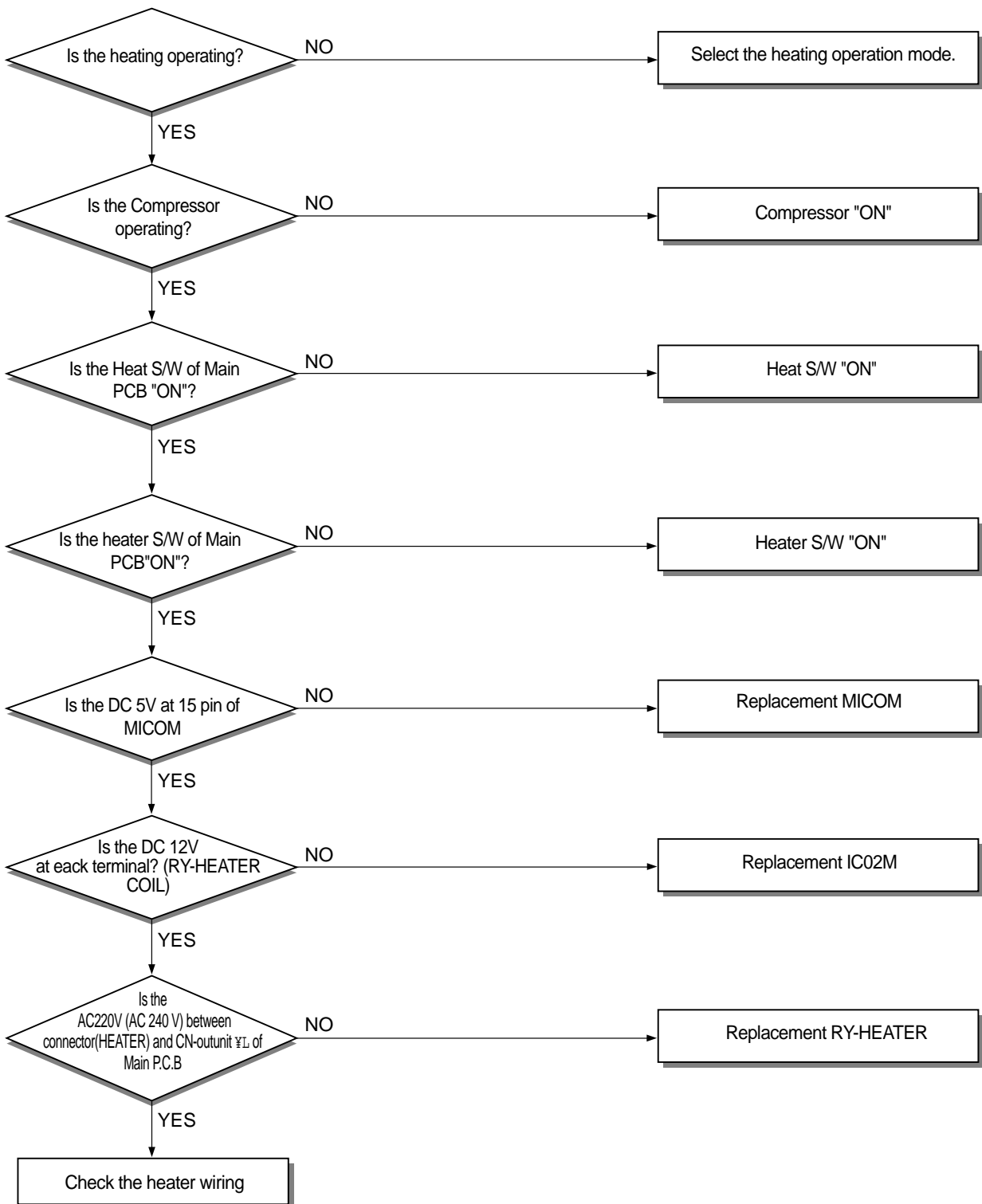

Electronic control device

• MAIN P.C.B ASM

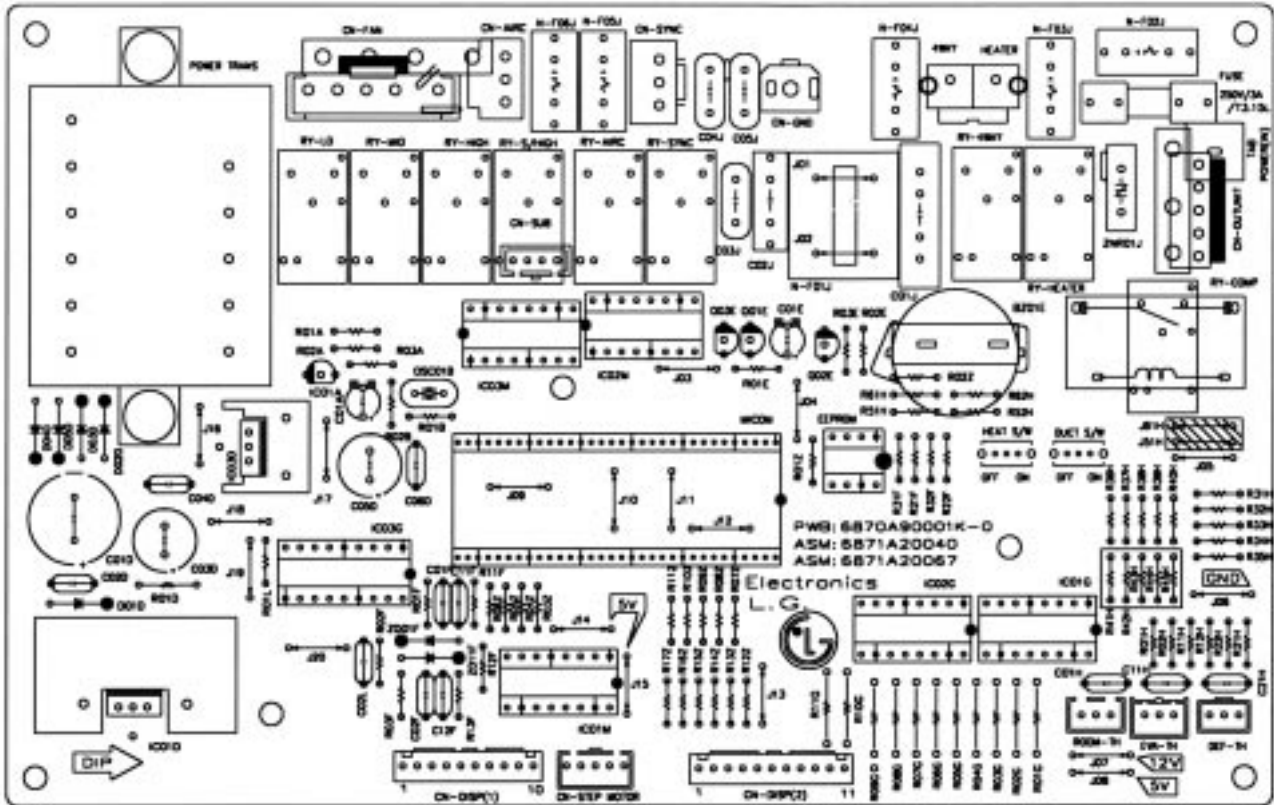

• DISPLAY P.C.B ASM

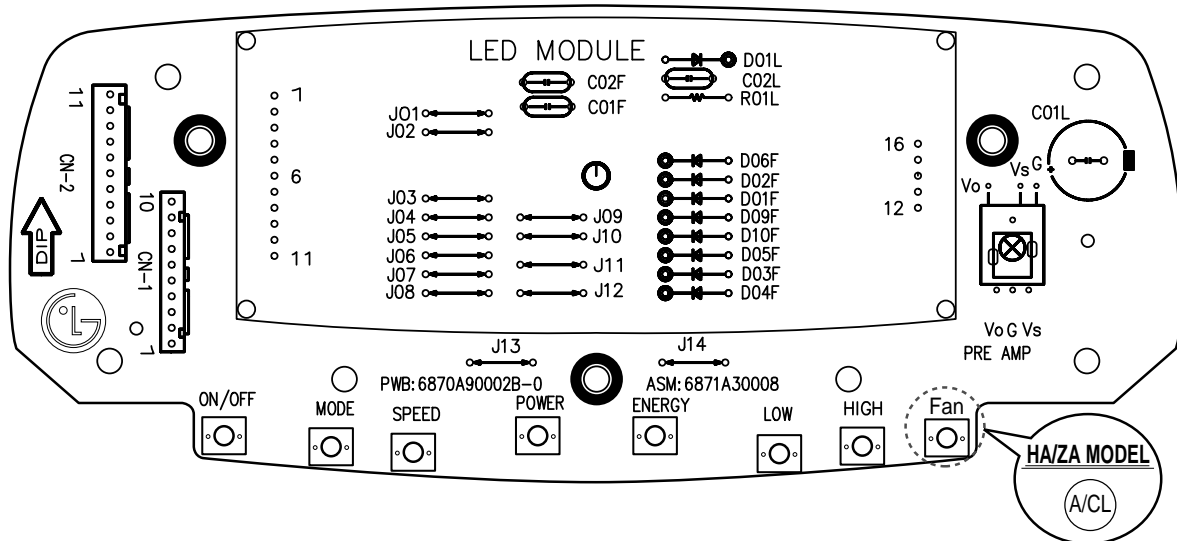

Schematic Diagram

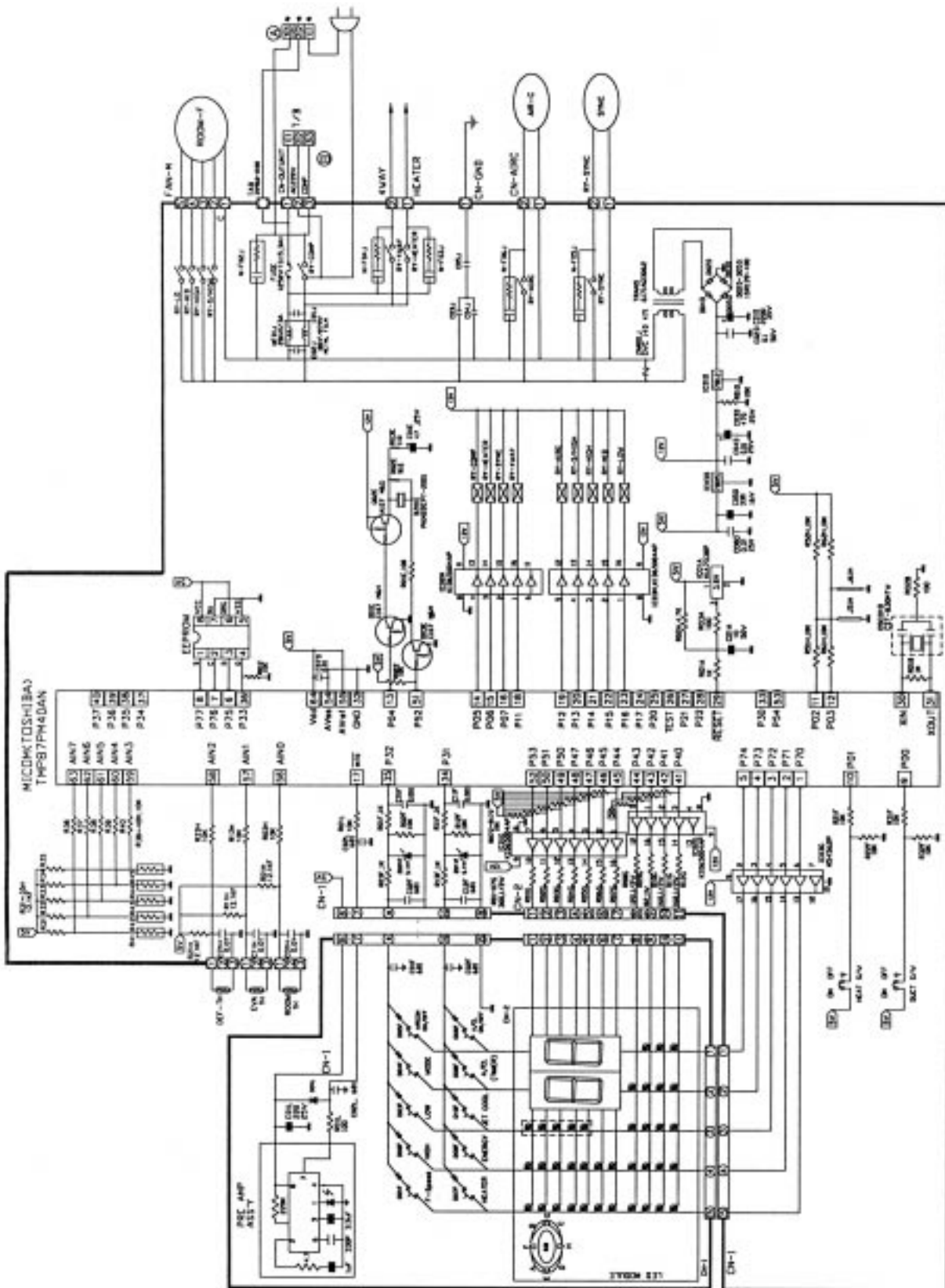

Exploded View and Replacement Parts List

1. Indoor Unit

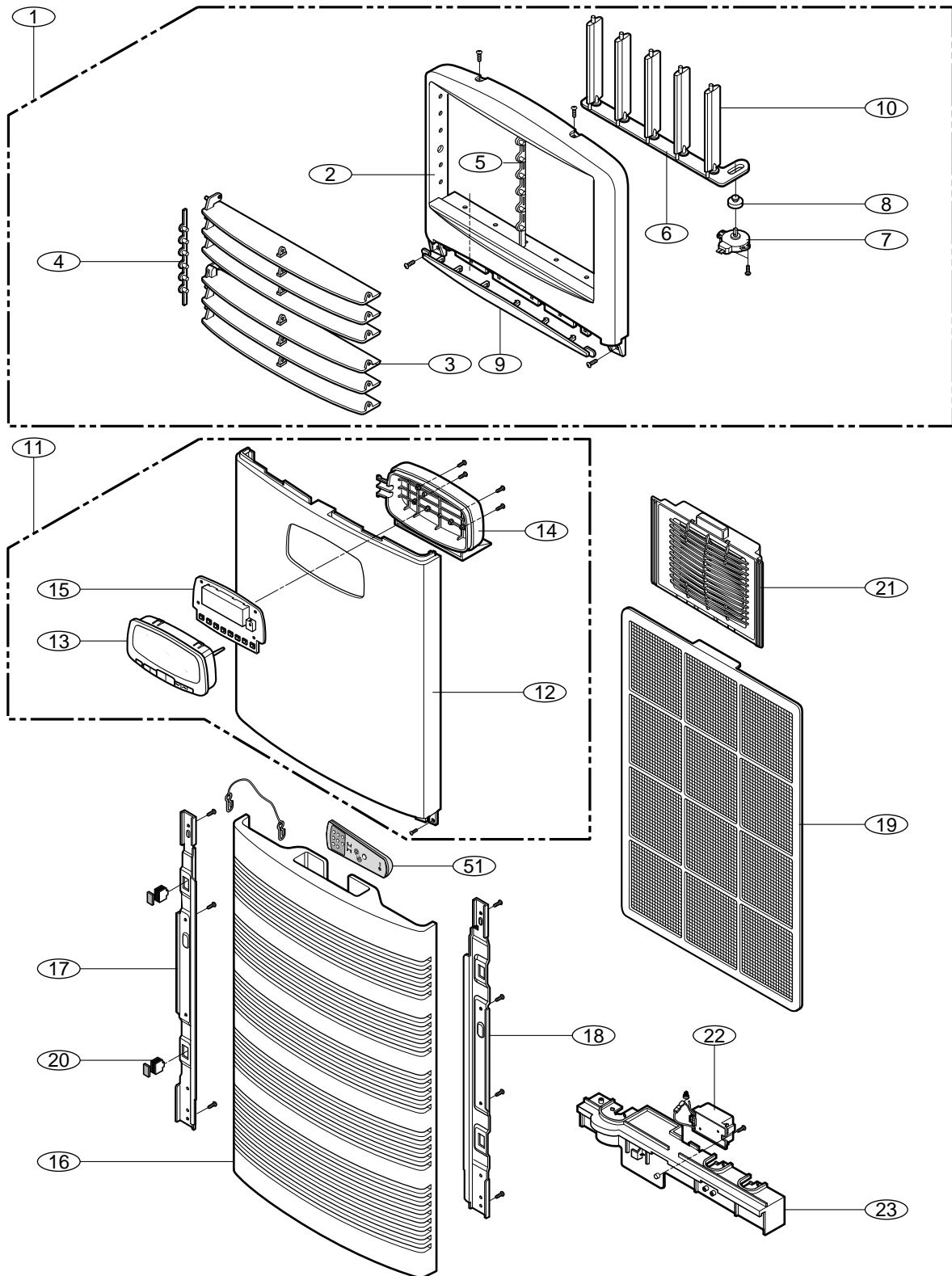

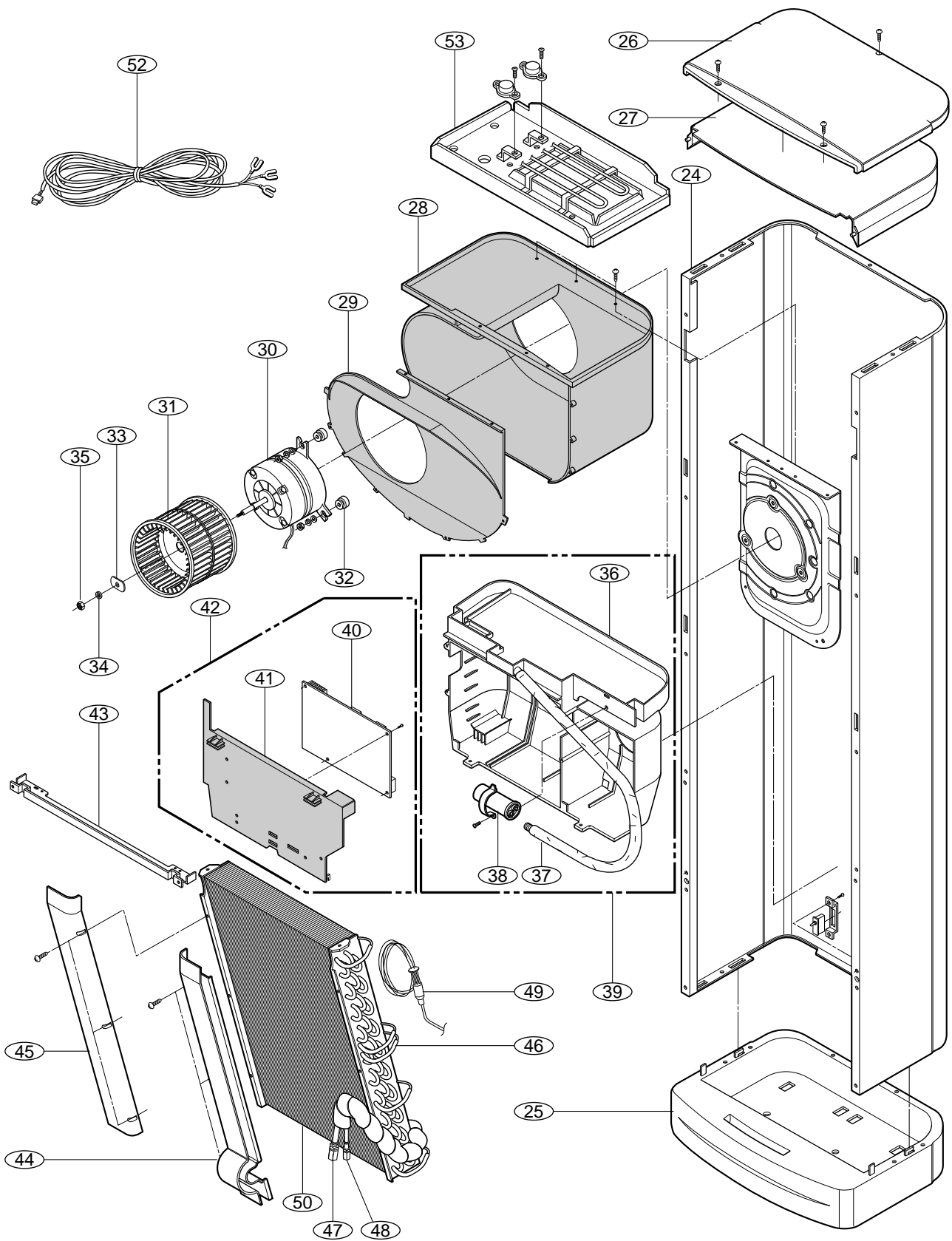

Parts List (Indoor Unit)

No.	PARTS NAME	PART No.	Q'TY			REMARK
			LP-K3060HL LP-K3060HA	LP-K3020HL LP-K3020HA	LP-K3060ZL LP-K3060ZA	
1	FRAME DIFFUSERR ASSY	3531A10011C	1	1	1	
2	FRAME DIFFUSER	3210A10001	1D	1D	1G	
3	LOUVER HORIZONTAL	4758A30003B	6	6	6	
4	LINK HORIZONTAL	4520A30007B	1	1	1	
5	SUPPORT-H	4980A30007B	1	1	1	
6	LINK HORIZONTAL	4520A30008A	1	1	1	
7	SYNCHRONOUS MOTOR	2H01102A	1	1	1	
8	CAM	3A01947A	1	1	1	
9	DECO	3508A30003B	1	1	1	
10	LOUVER VERTICAL	3A01943	5C	5C	5F	
11	PANEL FRONT ASSY	3721A20006	1T 1S	1T 1S	1T 1S	
12	PANEL FRONT SUB A	3721A20007C	1	1	1	
13	HOLDER DISPLAY ASSY	4931A20001	1W 1V	1W 1V	1W 1V	
14	COVER DISPLAY	3550A20004A	1	1	1	
15	DISPLAY PCB	6871A30008F	1	1	1	
16	GRILLE INLET	3530A10011B	1	1	1	
17	GUIDE FILTER	4974AP2034A	1	1	1	
18	GUIDE FILTER	4974AP2034B	1	1	1	
19	FILTER	5230AP3116A	1	1	1	
20	MAGNET ASSY	4A70152B	2 4	2 4	2 4	
21	A/CL UNIT ASSY	5983AP1156C	- 1	- 1	- 1	
22	SUPPORTER ASSY	4980AP1154A	- 1	- 1	- 1	
23	H.V ASSY	6609AQ2219	- 1C	- 1A	- 1C	
24	CABINET ASSY	3091AP1226E	1	1	1	
25	BASE ASSY	3041A20003B	1	1	1	
26	TOP COVER	3551A30019B	1	1	1	
27	GUIDE ASSY	4975AP3778A	1	1	1	
28	HOUSING	3660AP1221A	1	1	1	
29	HOUSING	3660AP1221A	1	1	1	
30	HOUSING SIDE	3660AP1222A	1	1	1	
31	MOTOR	4681AP2949	1D	1E	1D	

No.	PARTS NAME	PART No.	Q'TY			REMARK
			LP-K3060HL LP-K3060HA	LP-K3020HL LP-K3020HA	LP-K3060ZL LP-K3060ZA	
31	BLOWER	5834AP1097A	1	1	1	
32	RUBBER	5040AP4082A	3	3	3	
33	LOCKER	4A01405C	1	1	1	
34	SPRING LOCK WASH	1WSD0800030	1	1	1	
35	NUT	1NHA0801206	4	4	4	
36	DRAIN PAN	3086AP1217A	1	1	1	
37	DRAIN HOSE	5251AR1222J	1	1	1	
38	CAPACITOR	3H00611C	-	1	1	
		2H00841J	1	-	-	
39	DRAIN PAN ASSY	3087AP2581	1B	1A	1C	
40	MAIN PCB ASSY	6871A20067	1K	1M	1K	
			1L	1N	1L	
41	COVER CONTROL	3550AP2516D	1	1	1	
42	CONTROL BOX ASSY	4995A20084	1G 1J	1K 1E	1H 1F	
43	BRACKET EVA ASSY	4811AP3771A	1	1	1	
44	BRACKET, EVA SIDE	4811AP2587A	1	1	1	
45	BRACKET, EVA SIDE	4811AP2586A	1	1	1	
46	TUBE CONNECTION	5211AP4052A	1	1	6	
47	TUBE DIS ASSY	5211A30179B	1	1	1	
48	TUBE SUCTION ASSY	5211AP3768B	1	1	1	
49	CAPILLARY ASSY	5211A30037	1M	1G	1M	
50	EVA COIL ASM	5420AP2577G	1	1	1	
51	REMOCON	6711A20021	1V 1T	1V 1T	1U 1S	
52	CONNECTION WIRE ASSY	3A02517F	1	1	1	
53	ELECTRIC HEATER	3720AP2975B	-	-	1	

2. Outdoor Unit

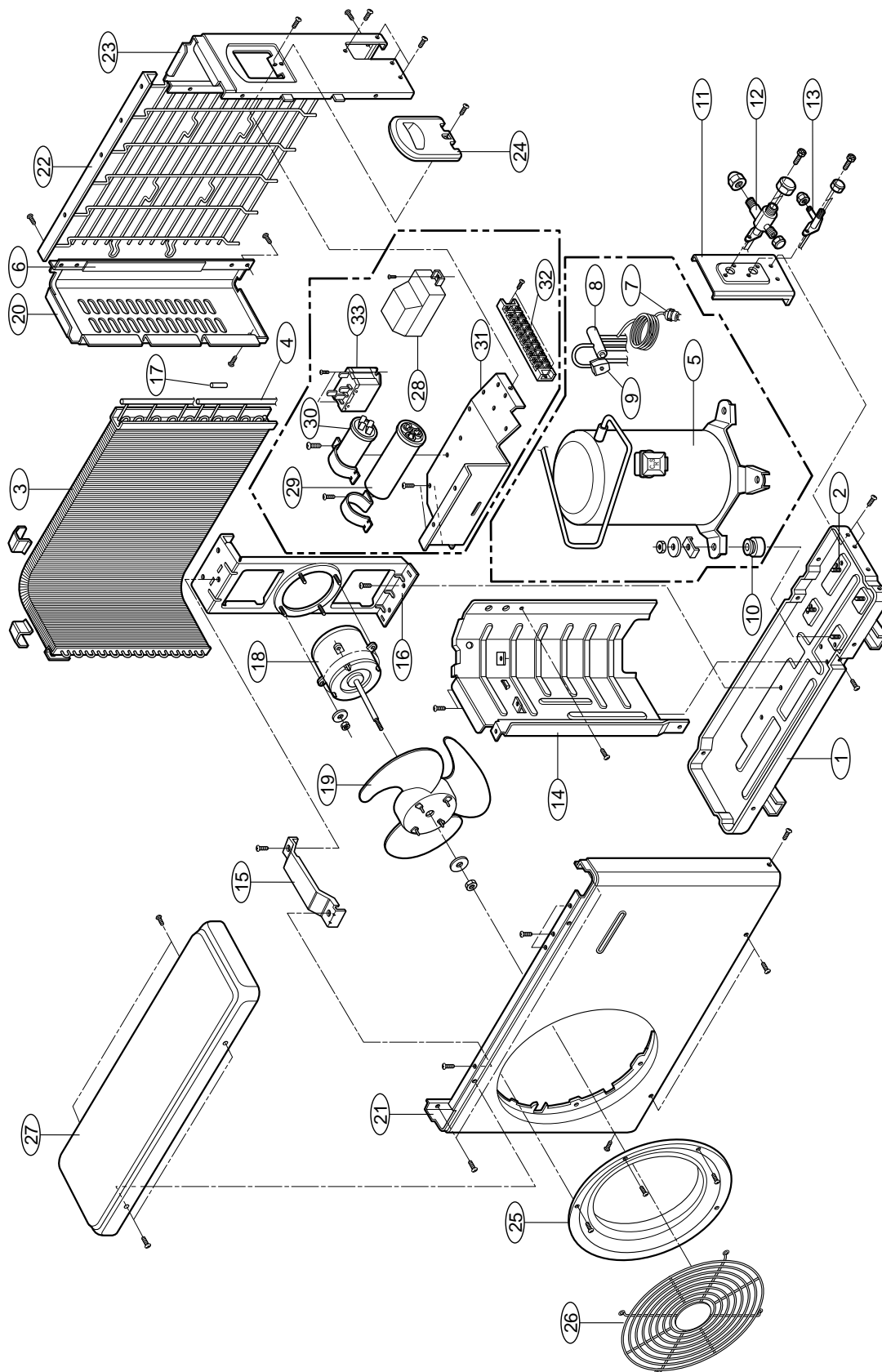

Parts List (Outdoor Unit)

No.	PARTS NAME	PART No.	Q'TY			REMARK
			LP-K3060HL LP-K3060HA	LP-K3020HL LP-K3020HA	LP-K3060ZL LP-K3060ZA	
1	BASE W. ASSY	2A02084K	1	1	1	
2	SCREW WELD	4H00525B	4	4	4	
3	COIL BEND ASSY	6140AP2096Q	1	1	1	
4	CHECK VALVE	3A01020A	1	1	1	
5	COMP	2A01032A	1	-	1	
		5416AR1411J	-	1	-	
6	INSULATION	3A02194B	1	1	1	
7	HIGH PRESSURE SWITCH	3A02524A	1	1	1	
8	REVERSING VALVE	3A02027B	1	1	1	
9	REVERSING COIL ASSY	3A02028Y	1	1	1	
10	BUSHING	4A01335A	4	-	4	
		4022AR4279A	-	4	-	
11	SUPPORT VALVE	2A00921C	1	1	1	
12	VALVE SVC	2A00392E	1	1	1	
13	VALVE SVC	2A00393Q	1	1	1	
14	BARRIER ASSY	2A01043A	1	1	1	
15	BRACKET	3A01934A	1	1	1	
16	MOUNT MOTOR	1A00206B	1	1	1	
17	THERMISTOR ASSY	3q35015G	1	1	1	
18	MOTOR, FAN	4681A20008	1N	1P	1N	
19	EXTRA FAN	1A00195B	1	1	1	
20	PANEL SIDE -L	1A00202C	1	1	1	
21	FRONT PANEL	1A00197C	1	1	1	
22	REAR GRILLE	1A00208D	1	1	1	
23	PANEL SIDE-R	1A00204F	1	1	1	
24	COVER CONTROL	3A01919B	1	1	1	
25	ORIFICE	4948AP2527A	1	1	1	
26	DISCHARGE GRILLE	3530A20007B	1	1	1	
27	TOP COVER	2A00915F	1	1	1	
28	PWB ASSY DEICER	6871A20015R	1	1	1	
29	SH-CAPACITOR	2A00986A	1	1	1	
30	SH-CAPACITOR	2A00986D	1	1	1	
31	CONTROL PANEL	2A00929A	1	1	1	
32	TERMINAL BLOCK	3H00390A	1	1	1	
33	RELAY	6920AP3400A	1	1	1	

