

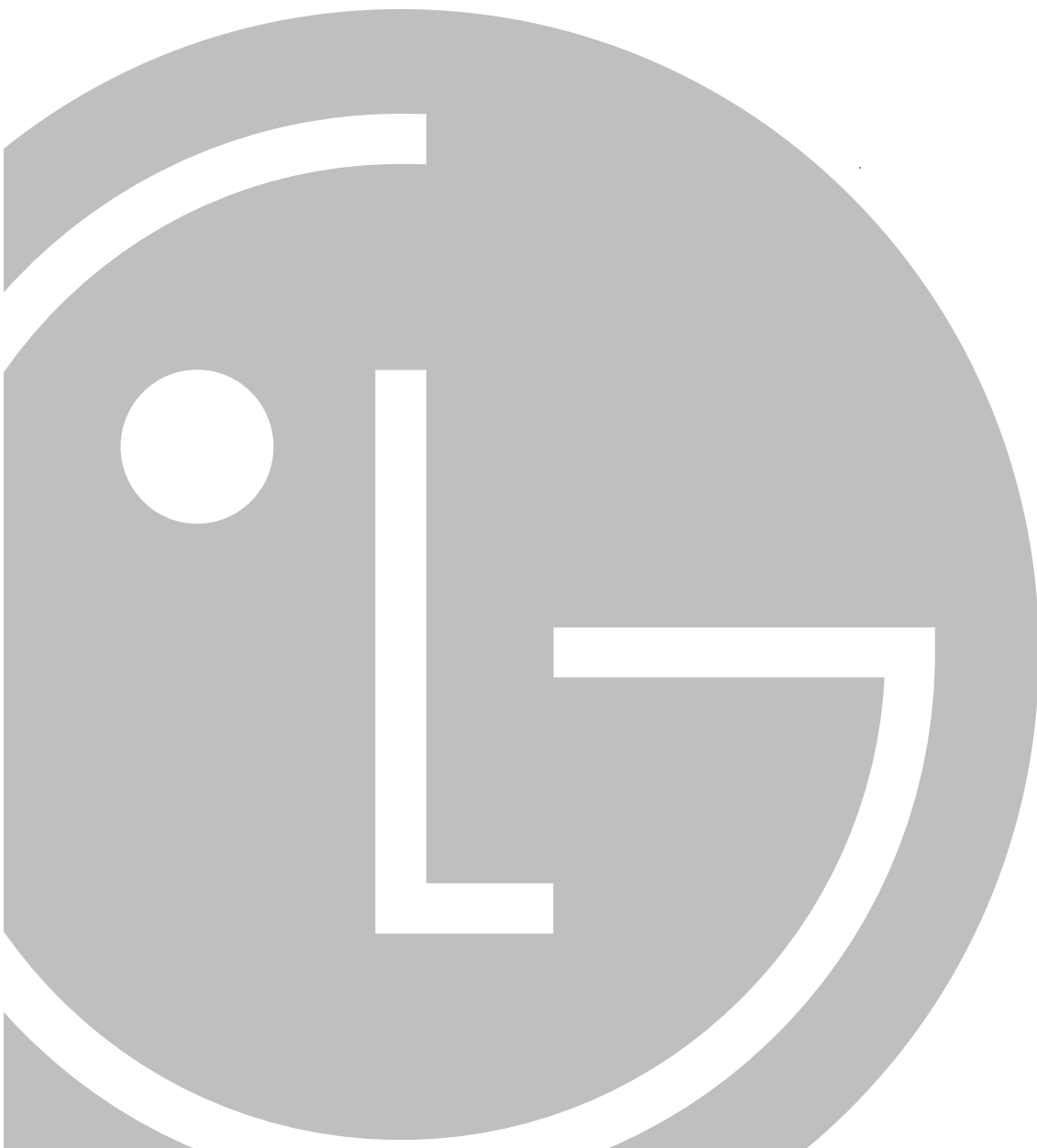

# Package Air Conditioner **SERVICE MANUAL**

MODEL: LP-F8081CL/HL/ZL



# Contents

---

1. Preface .....	3
2. Dimensions .....	7
3. Wiring Diagram.....	8
4. Operation Details .....	10
5. Installation .....	16
6. Operation .....	30
7. 3-Way Valve.....	31
8. Troubleshooting Guide .....	39
9. Electronic Control Device .....	52
10. Schematic Diagram .....	54
11. Exploded View and Replacement Parts List .....	55

# 1. Preface

---

This service manual provides various service information, containing the mechanical and electrical parts and etc. This package air conditioner was manufactured and assembled under the strict quality control system. The refrigerant is charged at the factory. Be sure to read the safety precautions prior to servicing the unit.

## 1.1 Safety Precautions

- When servicing the unit, set the main SWITCH to OFF and remove the POWER SUPPLY cables.
- Ⓛ Observe the original lead dress. If a short circuit is found, replace all parts which have been overheated or damaged by the short circuit.
- ∅ After servicing the unit, make an insulation resistance test to protect the customer from being exposed to shock hazards.

## 1.2 Features

- Design for cooling and heating
- Ⓛ Super energy efficiency
- ∅ Micom Control
- Ⓢ Whisper quiet operation
- ° Removable air filter
- 3 minute delay circuit
- 7 hour timer
- 3 step speeds for cooling/heating
- Auto Restart

## 1.3 Product Specifications

MODEL			LP-F8081CL	LP-F8081HL LP-F8081ZL
POWER SOURCE (ø, V, Hz)			3,380 – 415,50	3,380 – 415,50
COOLING	CAPACITY	Btu/h	71,400	71,400
		W	20,927	20,927
	INPUT	W	6,900	7,000
	CURRENT	A	12.0	13.0
HEATING (Including Electric heater)	CAPACITY	Btu/h (W)	–	74,000 (8,000)
		W (W)	–	21,680 (8,000)
	INPUT	W (W)	–	6,500 (8,000)
	CURRENT	A (A)	–	12.5 (12.0)
COMPRESSOR	MAKER		COPELAND	COPELAND
	TYPE		SCROLL	SCROLL
	MODEL		ZR94KC – TFD	ZR94KC – TFD
	INPUT	W	6,990	6,990
	CURRENT	A	13.6	13.6
	CAPACITY	Kcal/h	19,732	19,732
NOISE LEVEL(1m)	INDOOR	dB(A)	56	56
	OUTDOOR		65	65
AIR VOLUME	INDOOR	CMM	35	35
	OUTDOOR		104	104
REFRIGERANT R-22		Kg	5.9	7.2
HEAT EXCHANGER	INDOOR	R/C/FPI	3/33/17	3/33/17
	OUTDOOR	R/C/FPI	2/18/17	2/18/17
FAN	INDOOR	TYPE	SIROCO	SIROCO
	OUTDOOR		PROPELLER	PROPELLER
ROOM TEMPERATURE CONTROL			MICOM CONTROL	MICOM CONTROL
NET WEIGHT	INDOOR	Kg	132	132
	OUTDOOR		150	150
DIMENSIONS (W × H × D)	INDOOR	mm	1,050 × 1,880 × 495	1,050 × 1,880 × 495
	OUTDOOR		1,000 × 965 × 370	1,000 × 965 × 370
SVC VALVE	LIQUID	Inch (mm)	5/8	5/8
	GAS		1	1

## 1.4 Functions

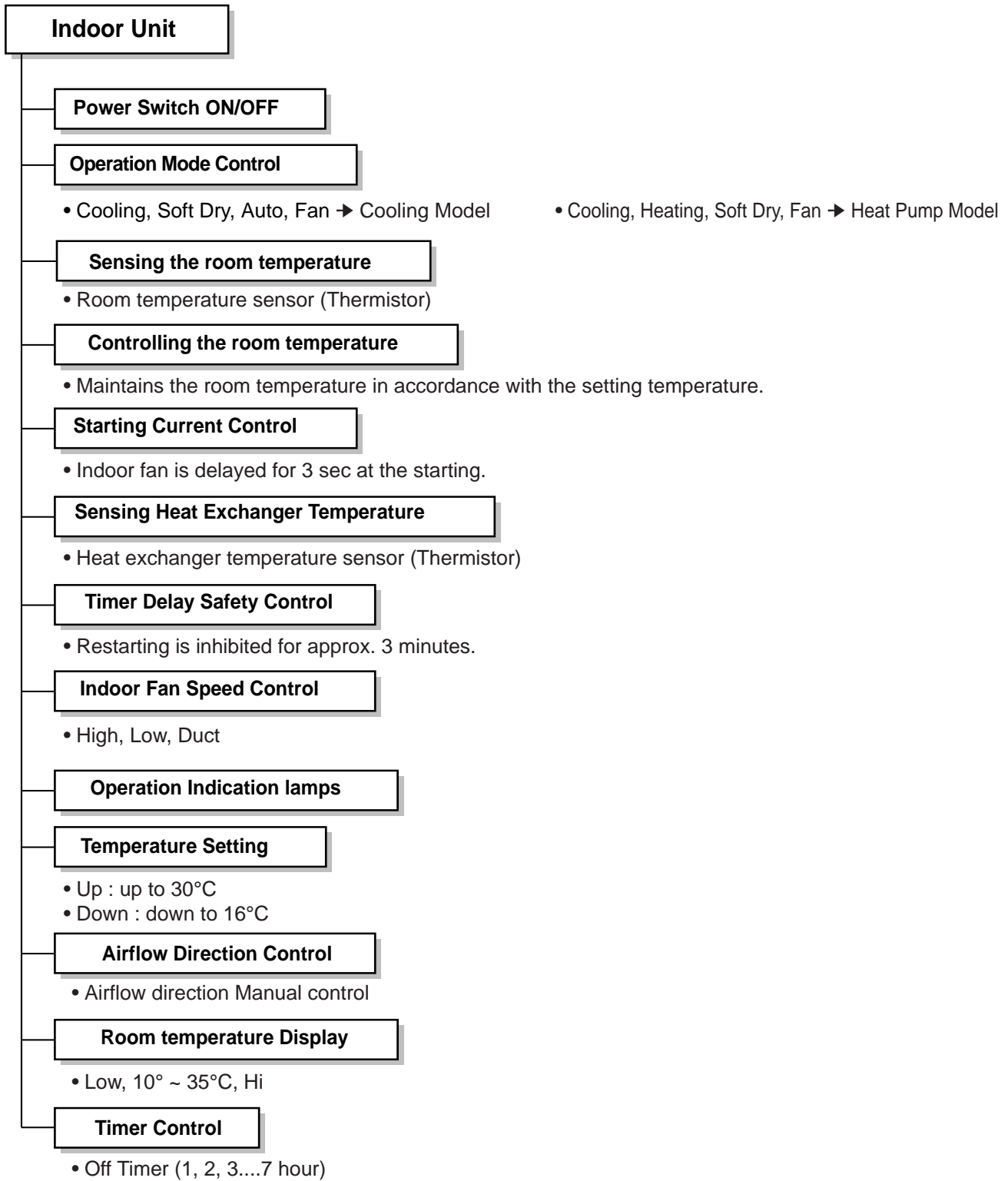

**Outdoor Unit**

**Deice Control**

- De-ice PCB

**Outdoor Fan Speed Control**

- One speed

**Sensing Heat Exchanger Temperature**

- Heat exchanger temperature sensor (Thermistor)

# 2. Dimensions

## Indoor Unit

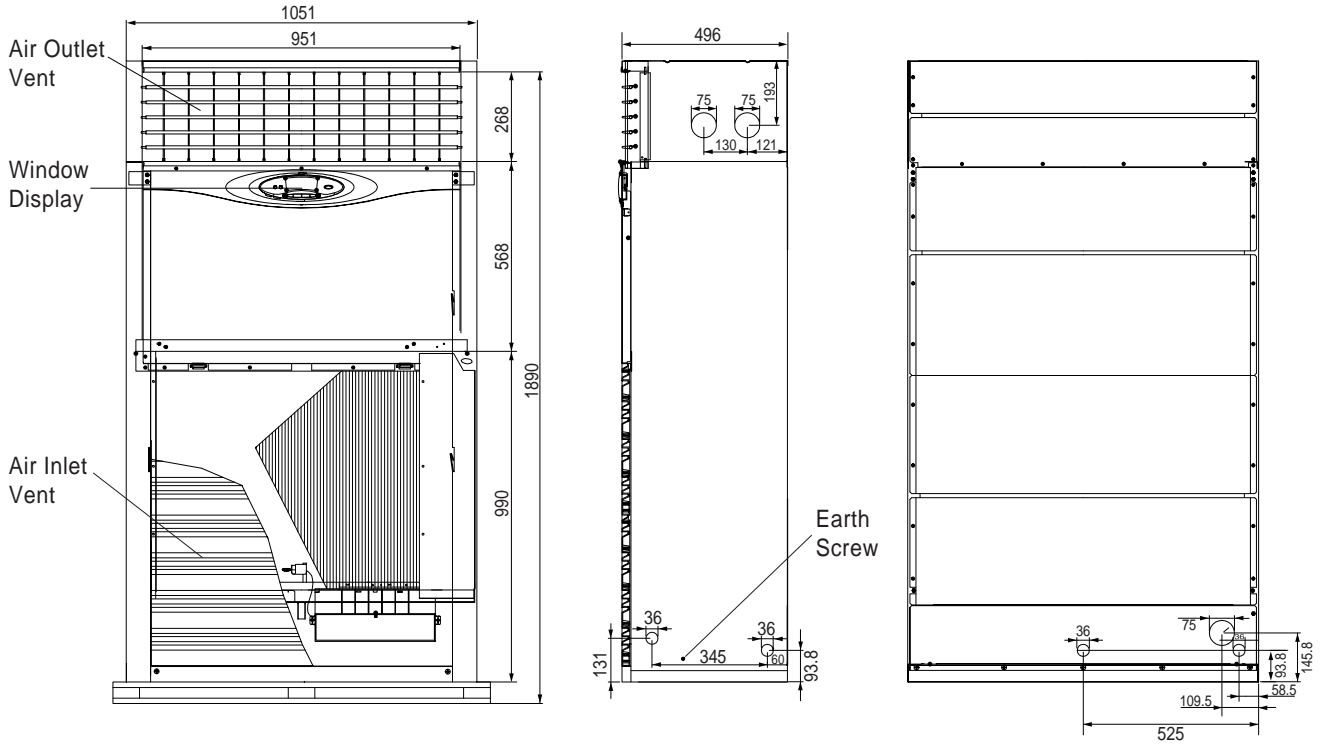

## Outdoor Unit

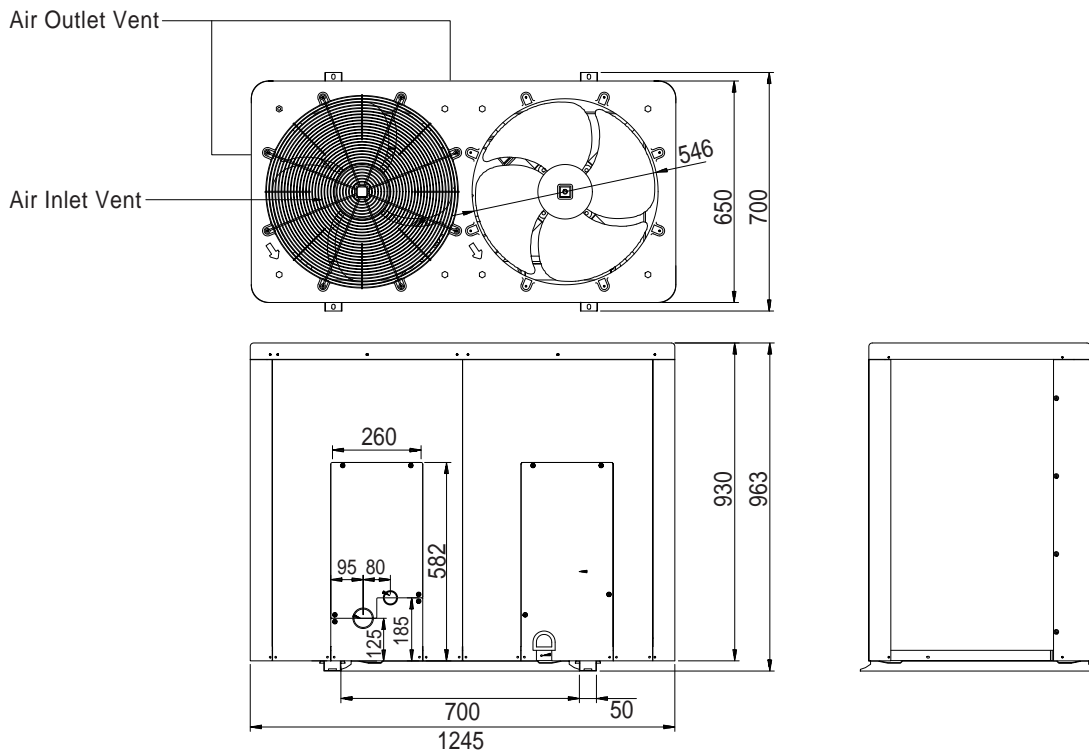

# 3. Wiring Diagram

## Indoor & Outdoor Unit Circuit Diagram

### (1) LD-F8081CL

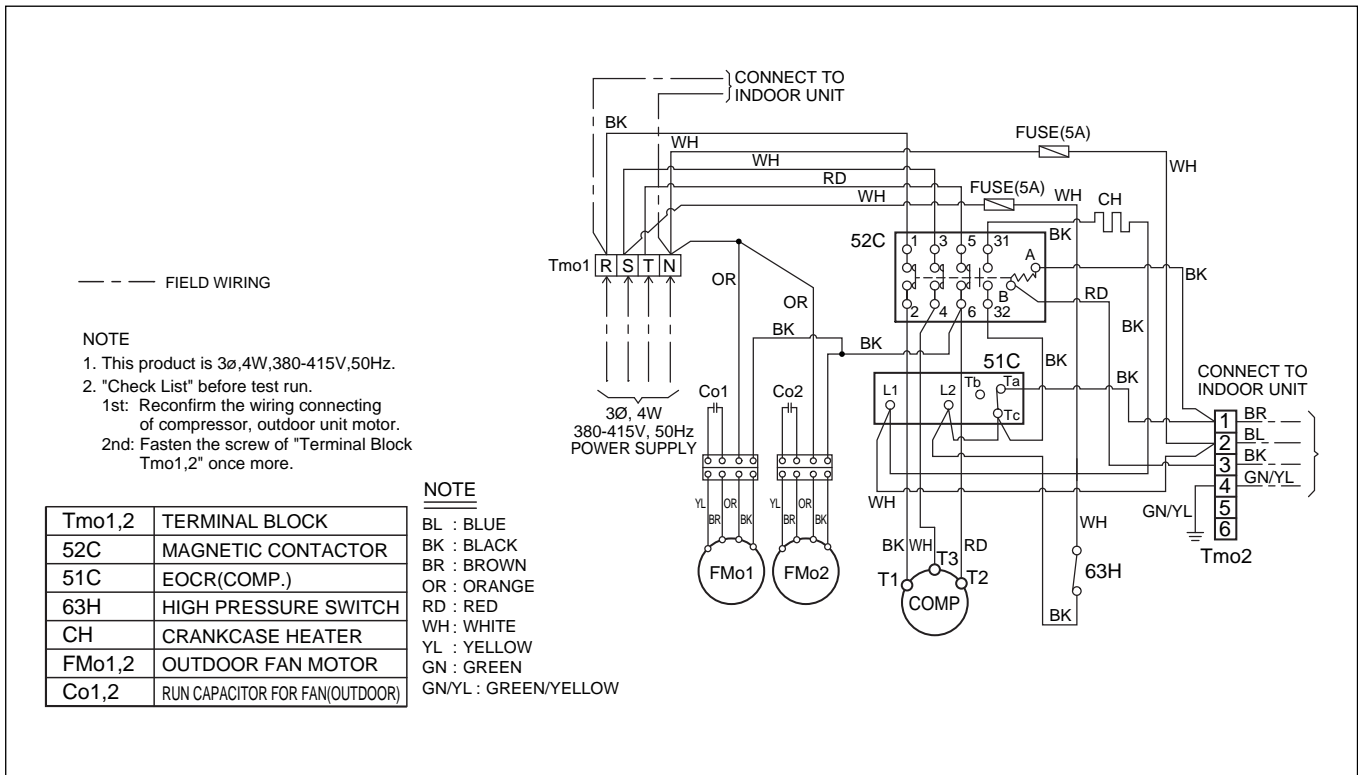
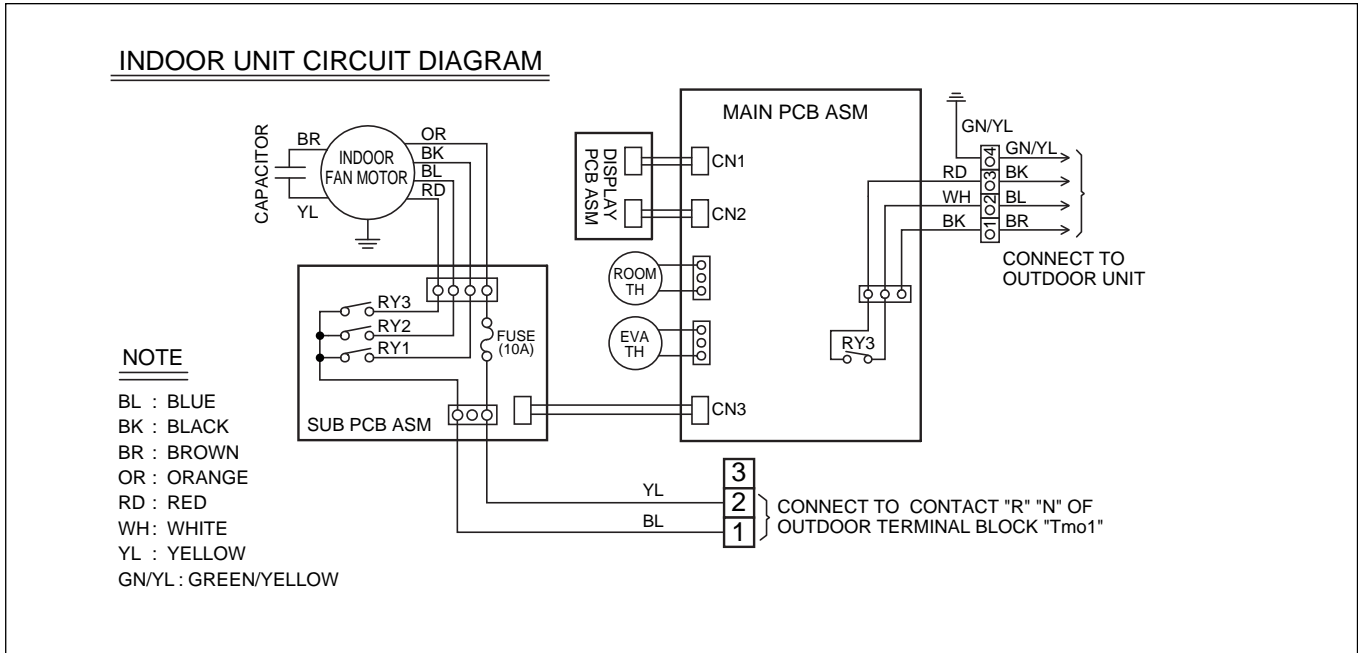



## (2) LD-F8081HL/ZL

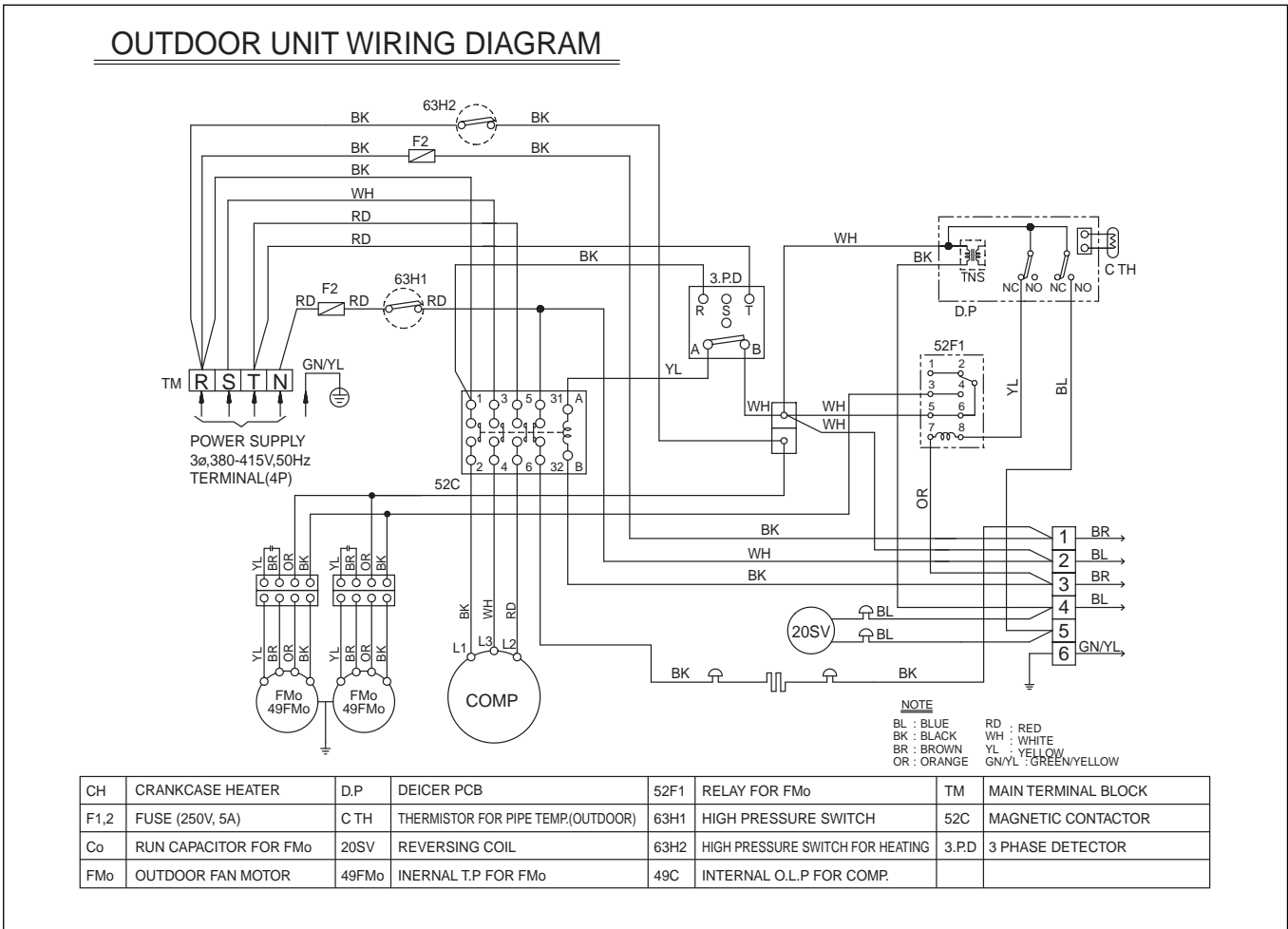
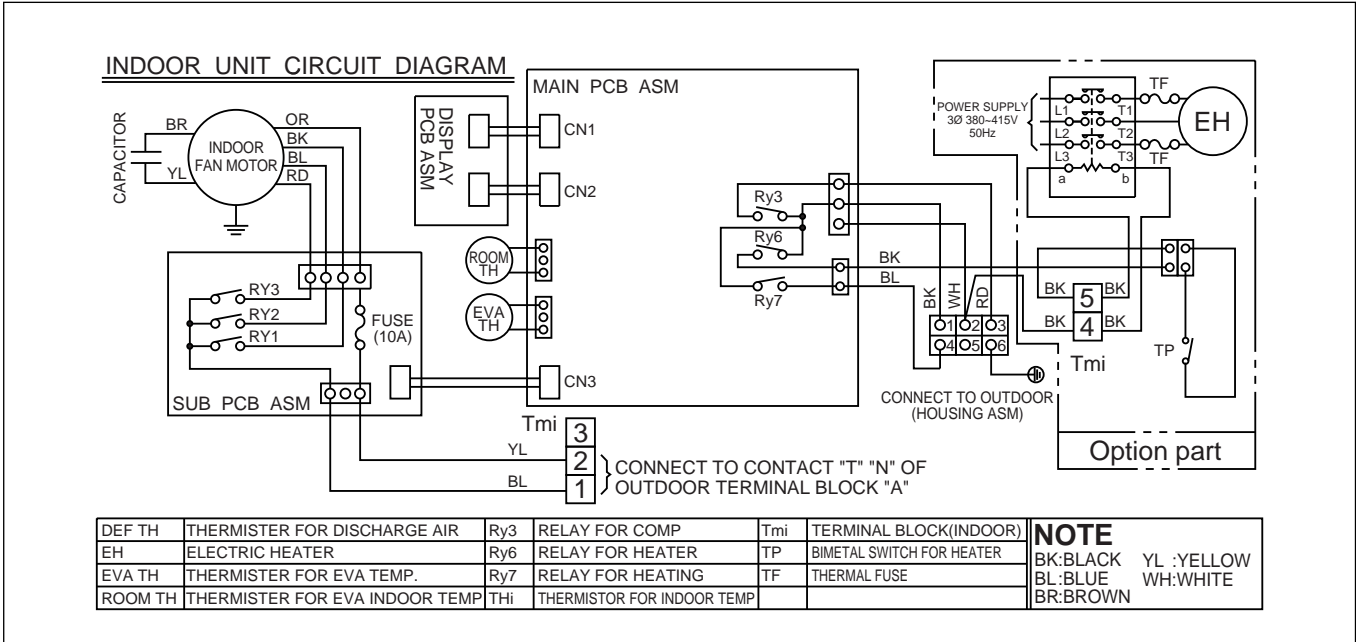

# 4. OPERATION DETAILS

## (1) The function of main control

### 1. Time Delay Safety Control

- 3min... The compressor is ceased for 3 minutes to balance the pressure in the refrigeration cycle.  
(Protection of compressor)
- 3sec... The indoor fan is ceased for 1~3 seconds to prevent relay noise.  
(Protection of fan relay and micro chip)
- 1min... The 4-way valve is ceased for 30 sec. to prevent the refrigerant-gas abnormal noise when the Heating operation is OFF or switched to the other operation mode.

### 2. Cooling Mode Operation

- When selecting the Cooling(❄) Mode Operation, the unit will operate according to the setting by the controller and the operation diagram is as following

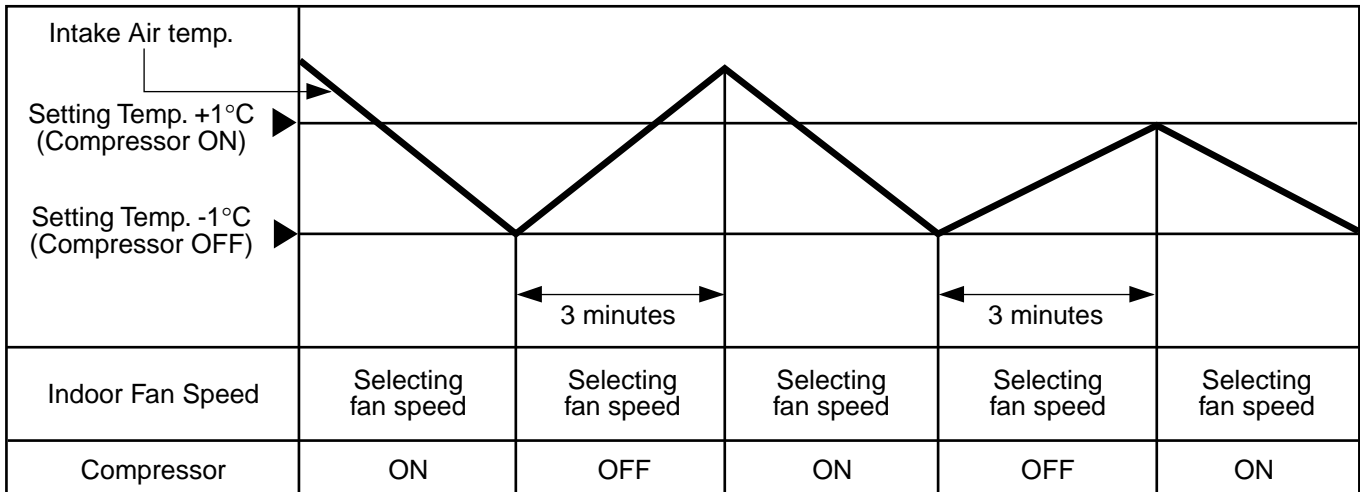

### 3. Auto Operation (Cooling Model only)

The operation procedure is as following.

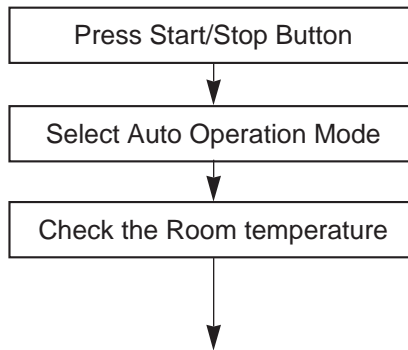

#### Auto Operation for Cooling

Operation Condition	Intake-air Temperature	Setting temperature	Fan speed
When Switch to Auto Operation	Over 26°C	25°C	Controlled by Fuzzy logic
	Over 24°C~below 25.5°C	Intake air -1.0°C	
	Over 22°C~below 23.5°C	Intake air -0.5°C	
	below 21.5°C	Intake air Temperature(18°C, MAX)	

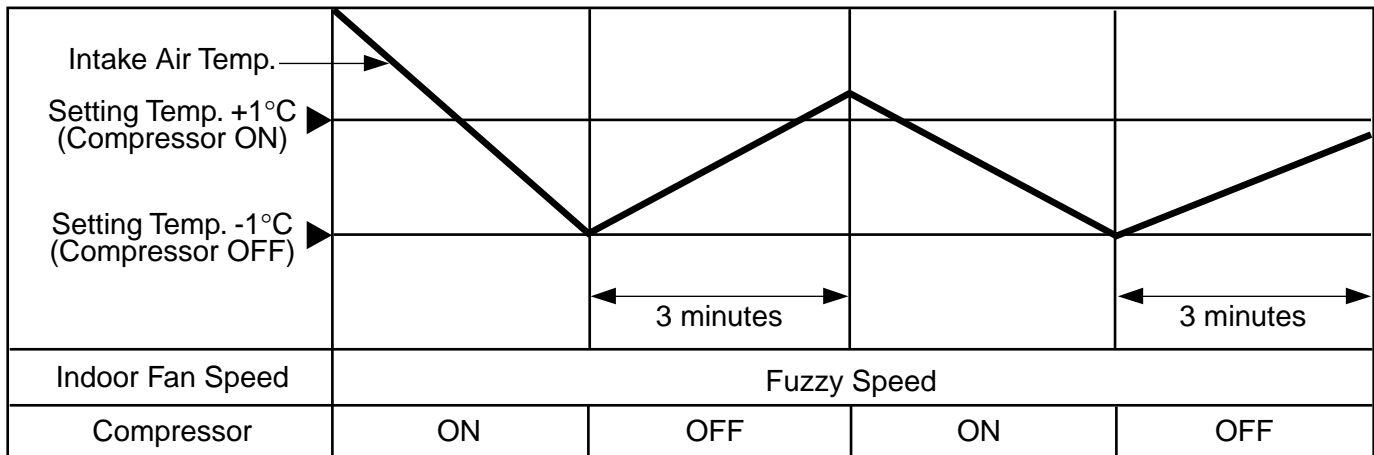

#### 4. Heating Mode Operation

The unit will operate according to the setting by the remote controller and the operation diagram is shown as following.

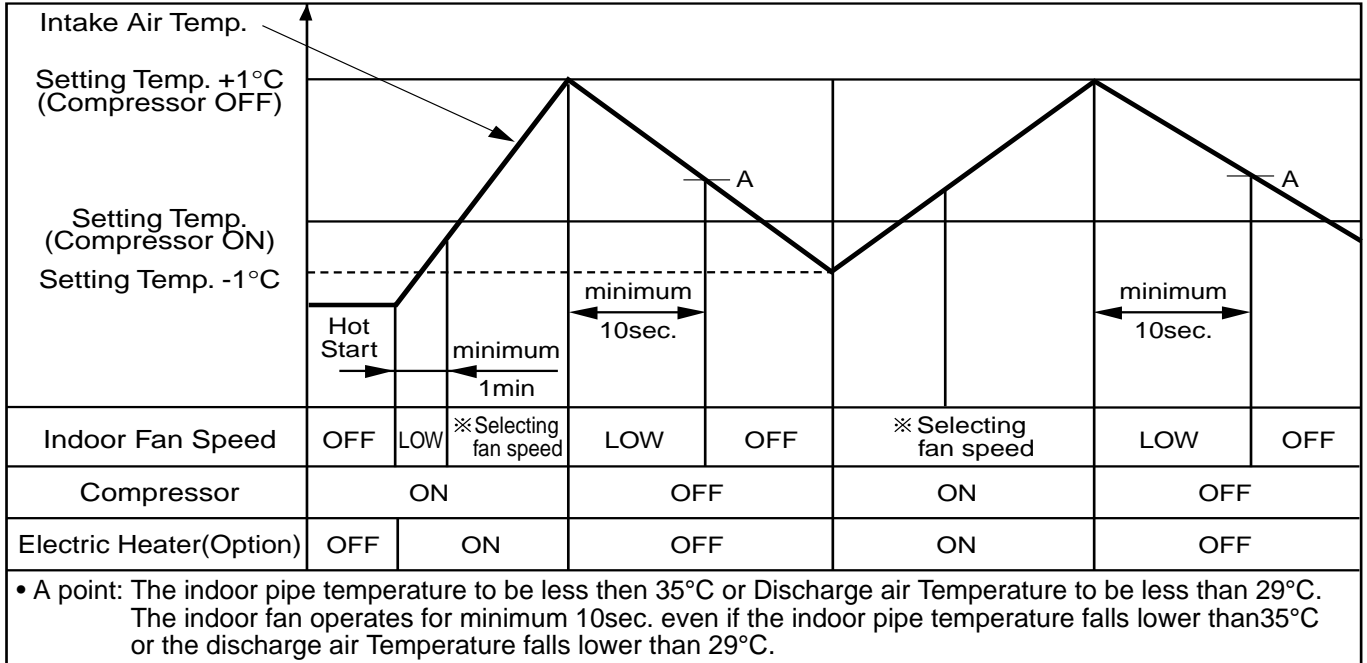

i During heating operation, the operating procedure of the indoor fan is as the following.

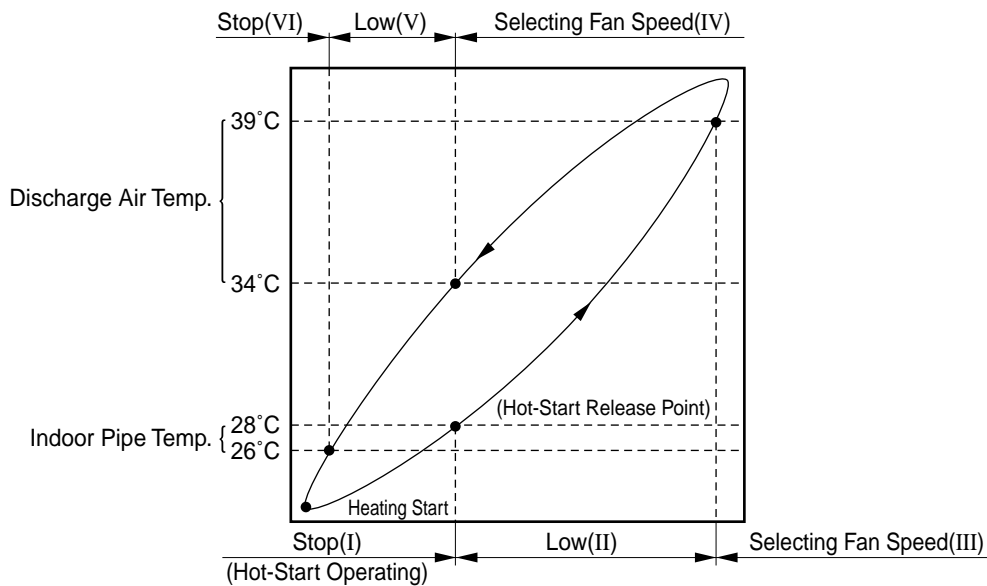

Step	Indoor fan speed	Pipe temp.	Air discharge temp.
☹	Off	≤28°C(Hot start operating)	—
☹-	Low	≥28°C	<39°C
☹+	Selecting speed	≥28°C	≥39°C
☹±	Selecting speed	≥28°C	>34°C
☹·	Low	≥26°C	≤34°C
☹	Off	≤26°C	—

## 5. Hot-Start Control

- The indoor fan stops until the evaporator piping temperature will be reached to 28°C.
- During heating operation, if piping temperatures fall below 26°C fan stops.
- The operation diagram is as following.

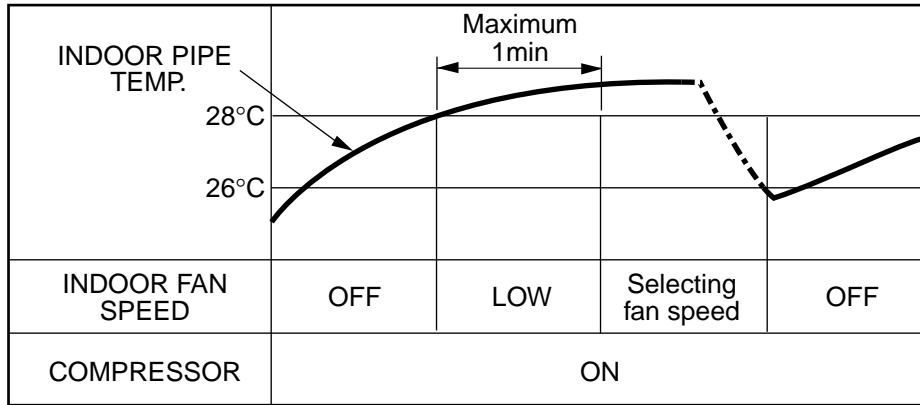

## 6. Defrost Control

- Defrost operation is controlled by timer and sensing temperature of outdoor pipe.
- The first defrost starts only when the outdoor pipe temperature falls below -6°C after 45 minutes passed from starting of heating operation and more than.
- Defrost ends after 10 minutes pass from starting of defrost operation or when the outdoor pipe temperature rises over 12°C even if before 10 minutes.
- The second defrost starts only when the outdoor pipe temperature falls below -6°C after 45 minutes pass from ending of the first defrost and more than.

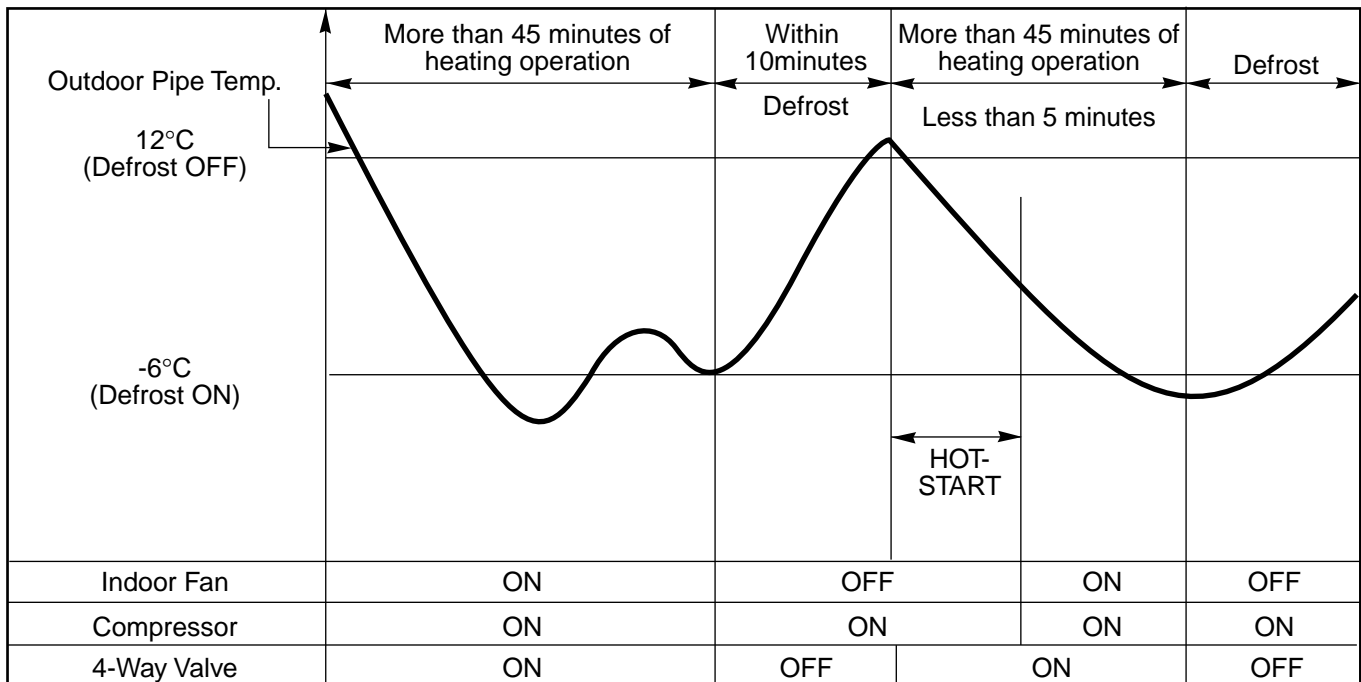

## 7. Soft Dry Operation Mode

- During Soft Dry Operation, the compressor ON temperature is the setting temperature plus 2°C, the compressor OFF temperature is the setting temperature minus 1°C.
- When the room temperature rises over the compressor ON temperature, the operation mode is switched to the Cooling mode.
- When the room temperature falls between the compressor ON temperature and OFF temperature, the operation mode is switched to the Soft Dry Operation.
- The operation diagram is shown below.

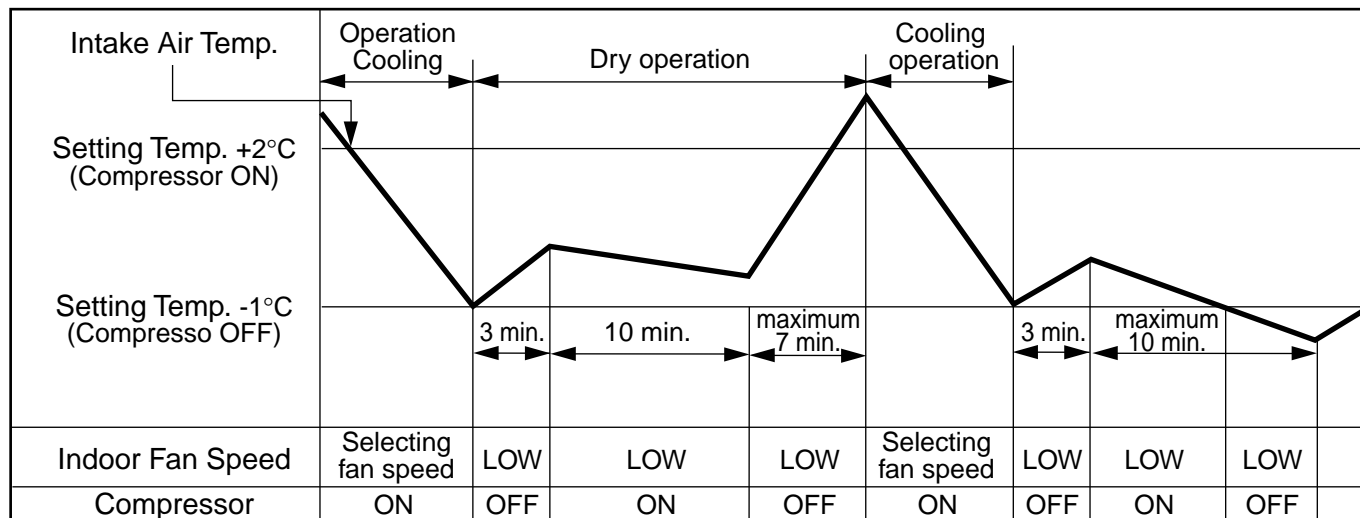

## 8. Protection of the evaporator pipe from frosting

- Compressor and outdoor fan stop when indoor pipe temperature is below -2°C and restart at the pipe temperature is above 12°C.

## 9. Child Lock function

This function is to operate Air conditioner only by Remocon.

The procedure is as the following

**1st:** Press the 2 buttons of the temperature control simultaneously, to raise-to lower on the Display Panel of the product for more 3 seconds.

**2nd:** The buzzer sounds and then the window of Display Panel shows *LOC* (LOC) mark.

**3rd:** To release this function, the reverse again the operating procedure could be done.

- During this function is operating, any buttons of Display Panel don't work. But it is possible to operate with Remote controller.

## 10. Off Timer Function

This function is to set the time of stopping the unit operation.

The procedure is as the following.

**1st:** Press the timer set button on the Remocon.

**2nd:** The buzzer sounds and then the display window shows the Off-Time to be set as 1:00; ...; 7:00; 0:00.

- The Off-Time is shifted as the following by each press.

→ 1:00 → 2:00 → 3:00 → 4:00 → 5:00 → 6:00 → 7:00 → 0:00

- If you select '0:00', the Off-Timer function will be cancelled.

- During Off-Timer Operation, if you repress the timer set button, the rest time will be displayed.

## 11. Alarm mode display / only displayed while operating.

**OH0** : The sensor for sensing room temperature is open or short.

**OH1** : The sensor for sensing piping temperature of evaporator is open or short.

## 12. Function for test operation.

This function shall be operated while the set not operating and start while set temperature set button(▼) down and start/stop buttons pressing continuously for 3 seconds.

If you press start/stop button continuously for 3 seconds while set temp down button pressing once more test operation and the set shall be stopped.

After test operation operating and 18 minutes, test operation and the set shall be stopped.

If you press start/stop button while test operation operating, test operation shall be stopped and the set shall start.

When test operation operating, the display of **88:88** shall be shifted to tEst

4-way valve is always off when test operation.

Fan speed is high, air purifying system and auto air flow operations are off when test operation.

Regardless of outside temperature, the set operates when test operation.

All but start/stop and air purifying system buttons cannot be set.

## 13. Function of changing set temperature when re-operation after stop.

Heating operation is set to the previous set temperature when re-operation after stop. Cooling operation is set to the previous set temperature when re-operation with start/stop button.

1.Operation mode.

Cooling/soft dry mode → Cooling mode

Heating mode → Heating mode

2. Setting the set temperature when cooling operation.

Room temperature > Set temperature: to be set to the previous set temperature.

Room temperature ≤ Set temperature

a) Room temperature ≥ 26°C: to be set to 24°C

b) 22°C ≤ Room temperature ≤ 25°C: to be set to 21°C

c) Room temperature ≤ 21°C: to be set to -1°C less than room temperature.

3. Setting the set temperature when heating operation.

Set the previous set temperature when stopped.

## 14. Auto Restart

In case the power comes on again a power failure, Auto Restarting Operation is the function to operate procedures automatically to the previous operating conditions.

# 5. Installation

## 5-1. Installation of Indoor, Outdoor unit

### 1) Selection of the best location

#### ① Indoor unit

- There should not be any heat source or steam near the unit.
- There should not be any obstacles to prevent the air circulation.
- A place where air circulation in the room will be good.
- A place where drainage can be easily obtained.
- A place where noise prevention is taken into consideration.
- Do not install the unit near the door way.
- Ensure the spaces indicated by arrows from the wall, ceiling, fence, or other obstacles.

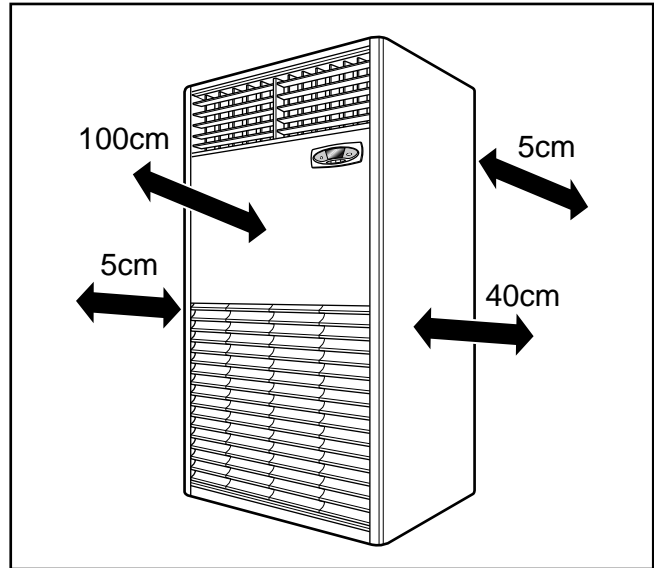

#### ② Outdoor unit

- If an awning is built over the unit to prevent direct sunlight or rain exposure, be careful that heat radiation from the condenser is not restricted.
- There should not be any animals or plants which could be affected by discharged hot air.
- Ensure the space indicated by arrows from the wall, ceiling, fence, or other obstacles.

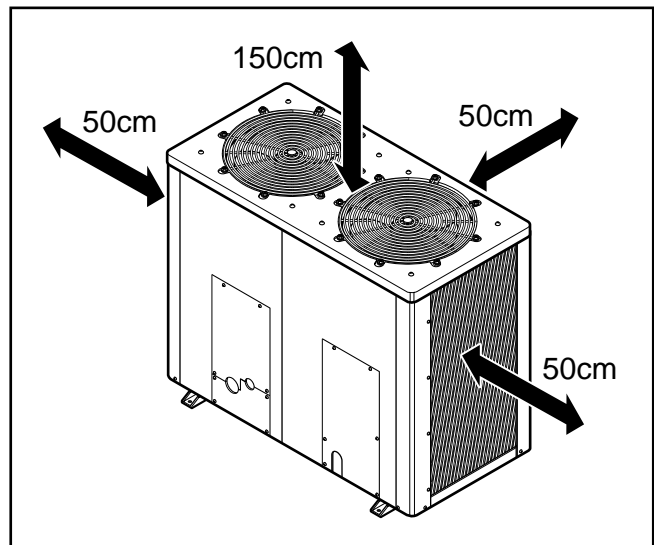

#### ③ Piping length and the elevation

MODEL	PIPE SIZE		Max. Length A (m)	Max. Elevation B (m)
	GAS SIDE	LIQUID SIDE		
80K (Btu/h)	1"	5/8"	50	35

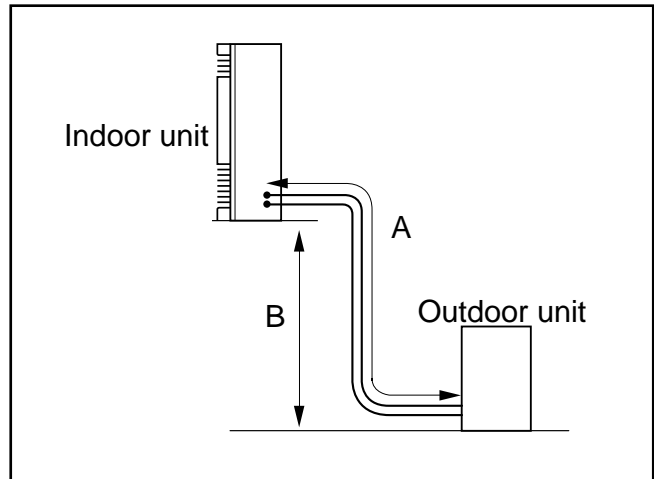



## 2) Indoor Unit installation

- ① The mounting floor should be strong and solid enough to prevent it from vibration.
- ② Drill the piping hole with 70mm diameter hole-core drill at either the right or the left of indoor unit. The hole should be slightly slant to the outdoor side.

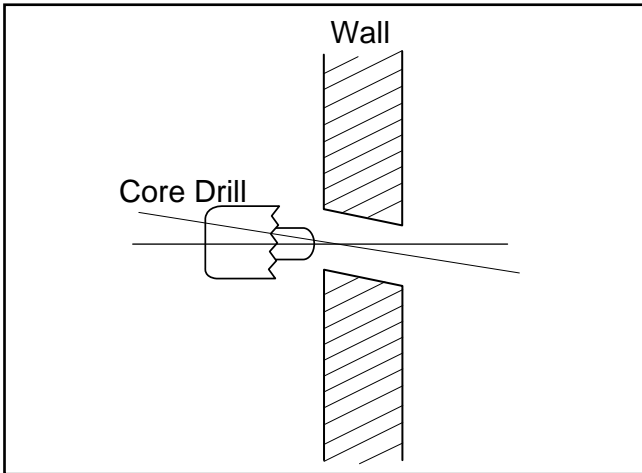
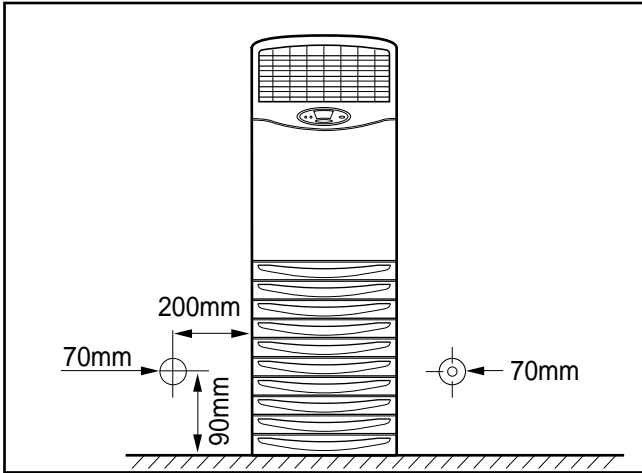

## 3) Outdoor unit Installation

- ① Install the outdoor unit on the concrete or any solid base securely and horizontally.
- ② If there is any vibration transmitted to the building, mount the rubber underneath the outdoor unit.

## 4) Refrigerant amount

Before shipment, this air conditioner is filled with the rated amount of refrigerant including additional amount required for air-purging, subject to 5m piping length. (The rated amount of refrigerant is indicated on the name plate.) But when the piping length exceeds 5 meters, additional charge is required according to the following table.

(Unit: g)

MODEL	REFRIGERANT CHARGE
80K	80 per 1m

Example) 72K~80K

In case of 10m long pipe(one-way), the amount of refrigerant to be replenished is:

$$(10 - 5) \times 80 = 400g$$

## 5-2. Installation Method

### 1) Procedure

No.	Installation works	Descriptions
1	Preparation of tools and installation parts	Preparation of installation
2	Flaring the pipes	To insert the flare nuts, mounted on the connection parts of both indoor and outdoor unit, onto the copper pipes.
3	Pipe bending	To reduce the flow resistance of refrigerant.
4	Connection of installation parts (elbows, socket etc)	Connection of long piping
5	Tighten the flare nut (outdoor)	Connecting the pipings of the outdoor unit.
6	Blowing the pipings	To remove dust and scale in working.
7	Tighten the flare nut (indoor)	Connecting the pipings of the indoor unit.
8	Check a gas-leakage of the connecting part of the pipings.	
9	Air purging of the piping and indoor unit	The air which contains moisture and which remains in the refrigeration cycle may cause a malfunction on the compressor
10	Open the 3-way (liquid side) and 3-way (gas side) valves.	
11	Form the pipings	To prevent heat loss and sweat
12	Checking the drainage (indoor unit)	To ensure if water flow drain hose of indoor unit.
13	Connecting the cable between outdoor and indoor unit	Preparation of the operating
14	Connecting the main cable to outdoor unit	
15	Supply the power to the crankcase heater (Before the operating the unit)	To prevent the liquid back to the compressor. (Heat pump only)
16	Cooling operation (Use the remote control or display of the indoor unit)	

## 2) Preparation of installation parts and tools

No.	Installation Parts, Tools	Use
1	Pipe cutter (MAX 35mm Copper pipe)	Cutting the pipings
2	Remear	Remove burrs from cut edges of pipes.
3	Wrench (H5, H4 hexagonal wrench)	To open the service valve
4	Pipe bender	Bending the pipings
5	Leak detector	Check a gas-leakage of connecting part of the pipings
6	Manifold gauge	To measure the pressure, to charge the refrigerant
7	Charge-nipple	To connect the bombe
8	Vacuum pump	To remove the air in the pipe.
9	Charge cylinder balance	To measure the refrigerant amount
10	Bombe (Freon-22)	Gas charge Air purge Cleaning the pipe
11	Spanner	To tighten the connecting parts of the pipings
12	Monkey spanner	
13	Driver( $\oplus, \ominus$ )	
14	Benchi (150mm)	Cutting the wires
15	Tapeline	To measure the length
16	Core drill	To make holes through the concrete wall and blocks
17	Voltmeter, Amperemeter, Clampmeter	To measure the current and voltage
18	Insulation resistance tester	To measure the insulation resistance
19	Glass thermometer	To measure the intake and outlet air temperature of the indoor unit
20	Copper tubes	To use the connecting pipings
21	Insulation material	To cover the connecting pipings
22	Tape	To finish the connecting pipings
23	Electrical Leakage Breaker	To shut off the main power
24	Cable	To connect the cable from outdoor unit to indoor unit
27	Drain hose sockets, elbows	To remote the condensing water

## 5-3. Piping of Indoor Unit

### 1) Preparation of piping

#### ① Cut the pipes and the cable

- Use the accessory piping kit or the pipes purchased locally.
- Measure the distance between the indoor and the outdoor unit.
- Cut the pipes a little longer than measured distance.
- Cut the cable 1.5m longer than the pipe length.

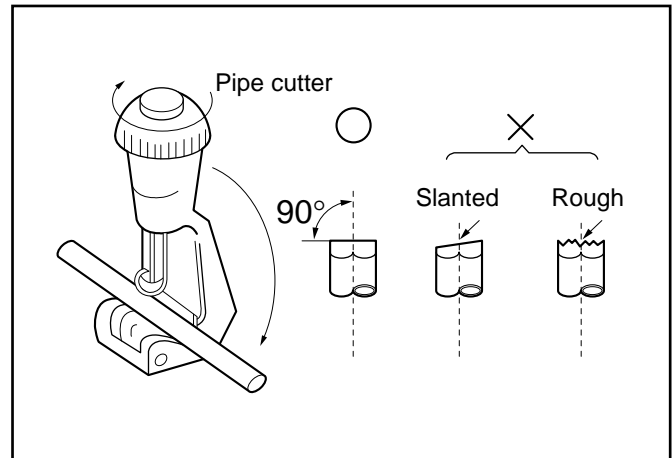

#### ② Remove burrs.

- Remove burrs from cut edges of pipes.
- Turn the pipe end down to avoid the metal powder entering the pipe.

#### Caution:

If burrs are not removed, they may cause a gas leakage.

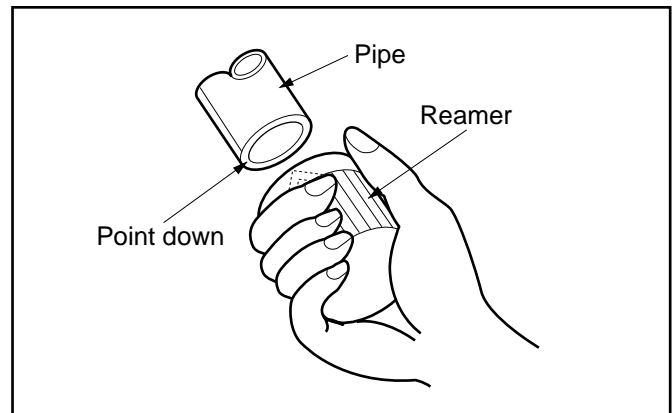

### 2) Connection of piping

#### ① Move the indoor tubing and drain hose to the hole

- Remove tubing holder and pull the tubing out of the chassis.

#### ② Replace the tubing holder into original position

#### ③ Route the tubing and the drain hose straight backwards.

#### ④ Insert the connecting cable into the indoor unit through the hole.

- Do not connect the cable to the indoor unit
- Make a small loop with the cable for easy connection later.

#### ⑤ Tape the tubing and the connecting cable.

#### ⑥ Indoor unit installation.

#### ⑦ Connecting the pipings to the indoor unit.

- Align the center of the pipings and sufficiently tighten the flare nut with fingers.
- Finally, tighten the flare nut with torque wrench until the wrench clicks.  
When tightening the flare nut with torque wrench, ensure the direction for tightening follows the arrow on the wrench.

### 3) Precautions in bending

- ① If it is necessary to bend or stretch the tubing, use the spring which is attached to the tubing in stead of pipe bender.
  - Please make a careful notice to make a smooth line.
  - Hold the tubing with your two hands closely and then bend or stretch it slowly not to make any crack.
  - Remember that the radius (R) should not exceed 70mm (Refer to Fig. 1)
- ② Do not repeat the bending process to prevent the tubing from cracking or crushing.
- ③ Keep in mind that the bending part should not be cracked and make the radius (R) as long as possible (Refer to Fig. 2)

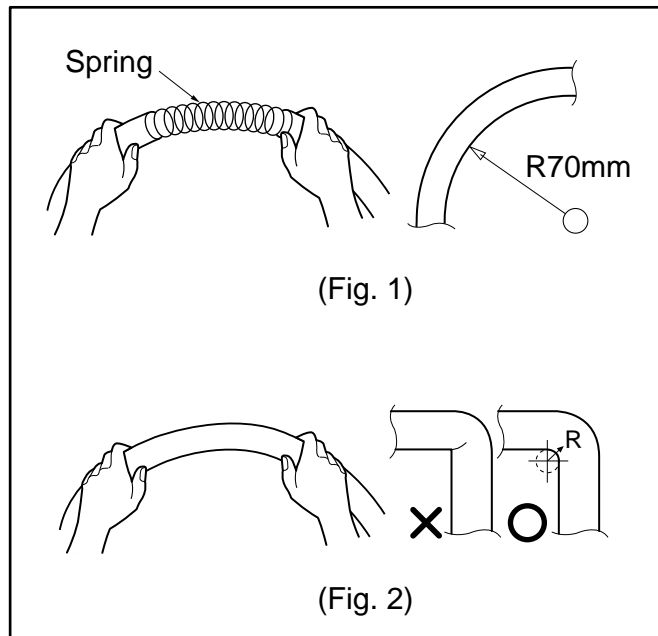

## 5-4. Connecting Piping to Outdoor Unit

### 1) Connecting pipings to the outdoor unit

- ① Upon connecting 4-way valves, please weld connecting pipes using elbows instead of connecting pipes with flare nuts.

## 5-5. Connecting the Cable

- ① Open the control board cover from the outdoor unit by removing the screws.
- ② Connect wires to the terminals on the control board individually and secure the cables onto the control board with clamp.

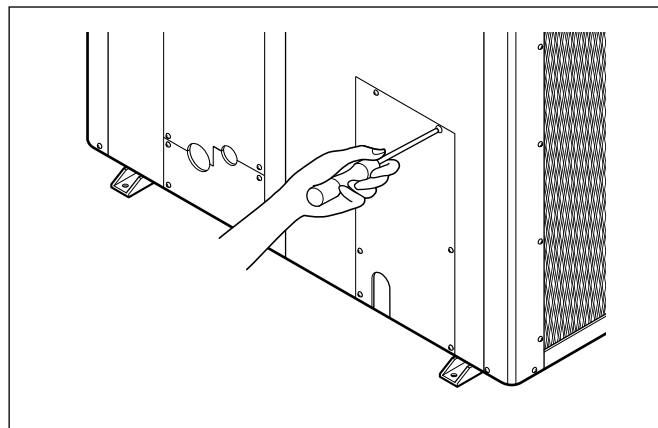

## 5-6. Power Supply and Wiring

The unit is completely wired internally at the factory according to general rule of electrical technology, but local rules, if they are required, should be complied with.

### 1) Power Supply

Power source must fulfill the following conditions:

- The working voltage should be higher than 90% and lower than 110% of the rated voltage marked on the name plate.
- The starting voltage should be higher than 85% of the rated voltage marked on the name plate.

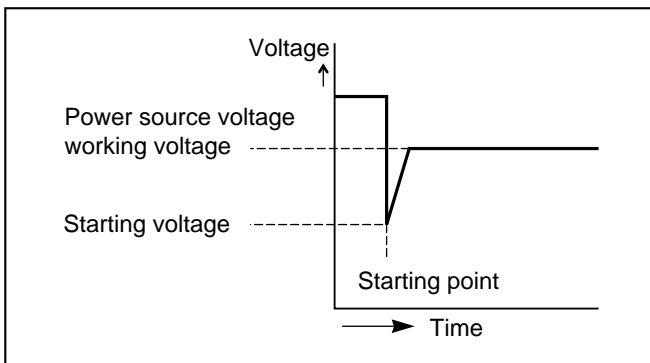

### 2) Wiring

After the confirmation of the above conditions, prepare the wiring as follows:

- Use the power supply cord (Rubber insulation, type Ho7RNF approved by HAR or SAA) suitable for the product's electrical capacity.

MODEL	VOLTS	Conductor cross-sectional area
80K (BTU/h)	450/ 750V	5.5mm <sup>2</sup>

- Provide a recognized circuit breaker as below between power source and unit.  
A disconnection device to adequately disconnect all supply lines must be fitted.  
(for service operations)

MODEL	Circuit breaker capacity
80K (BTU/h)	50A

- The screws which fasten the wiring in the casing of electrical fittings are liable to come loose from vibrations to which the unit is subjected during the course of transportation. Check them and make sure that they are all tightly fastened.  
(If they are loose, it could give rise to burn-out of the wires.)
- See to it that the starting voltage is maintained at more than 90 percent of the rated voltage marked on the name plate.
- The following troubles would be caused by voltage drop-down.  
Vibration of a magnetic switch, damage on the contact point there of, fuse breaking, disturbance to the normal function of a overload protection device.

## 5-7. Air Purging of the Piping and Indoor Unit

The air which contains moisture and which remains in the Refrigeration cycle may cause a malfunction on the compressor.

- Remove the caps from the 4-way(liquid side) and 4-way(gas side) valves.
- Remove the service-port cap from the 3-way (gas side) valve.
- To open the valve, turn the valve stem of 3-way (liquid side) valve counter-clockwise approx. 90° and hold it there for ten seconds, then close it.
- Check a gas-leakage of the connecting portion of the pipings.

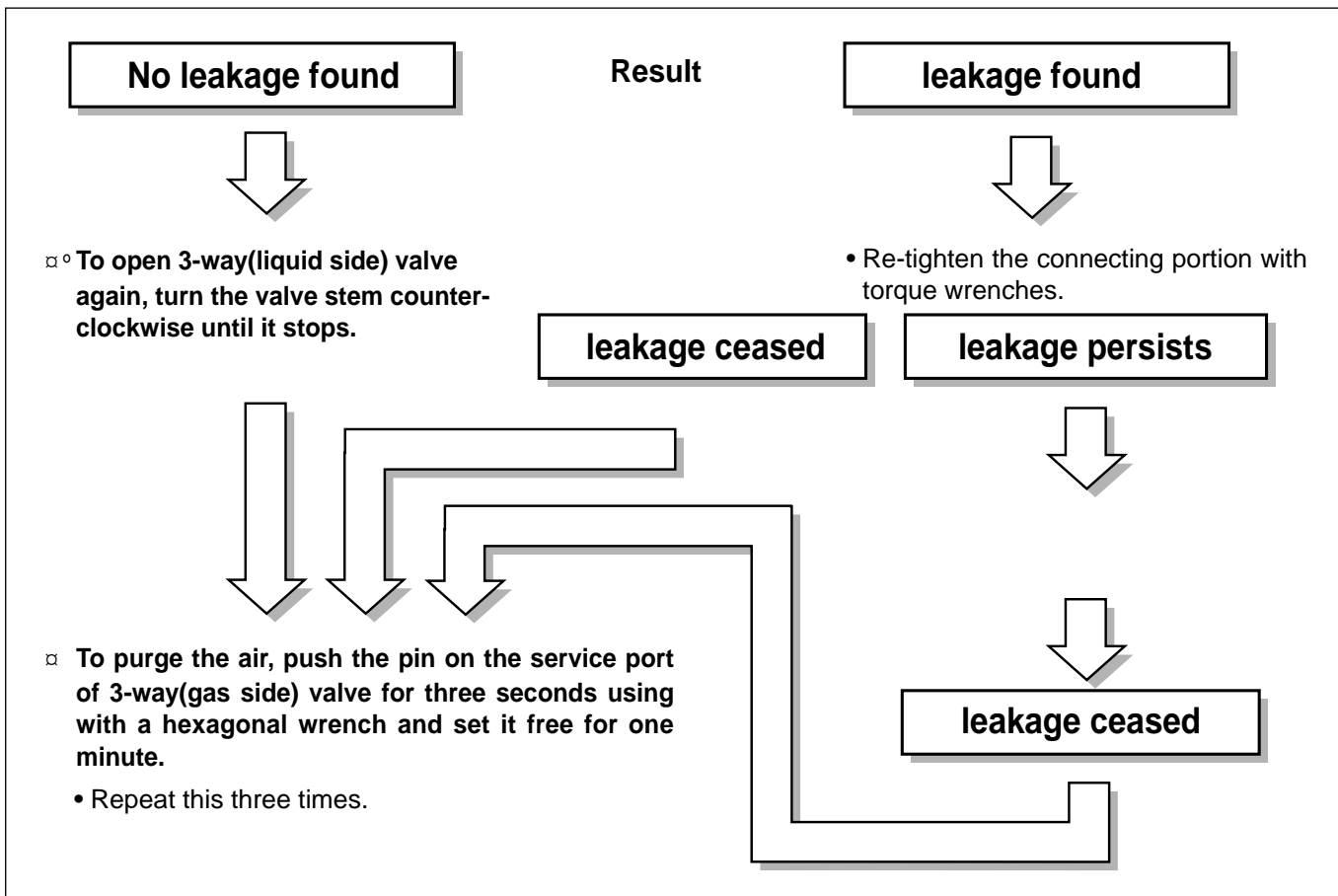
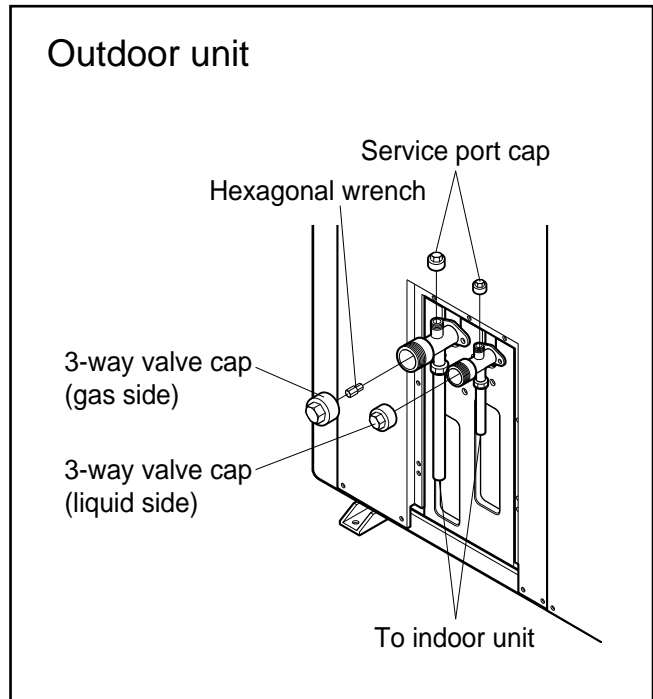

□ **Set the both 3-way(liquid side) and 3-way(gas side) valves to open position with the Hexagonal wrench for the unit operation.**

□ **Checking a gas leakage for the left piping**

- Connect the manifold gauge to the service port of 3-way(gas side) valve. Measure the pressure.
- Keep it for 5 - 10 minutes. Ensure if the pressure indicated on the gauge is as same as that of measured at first time.

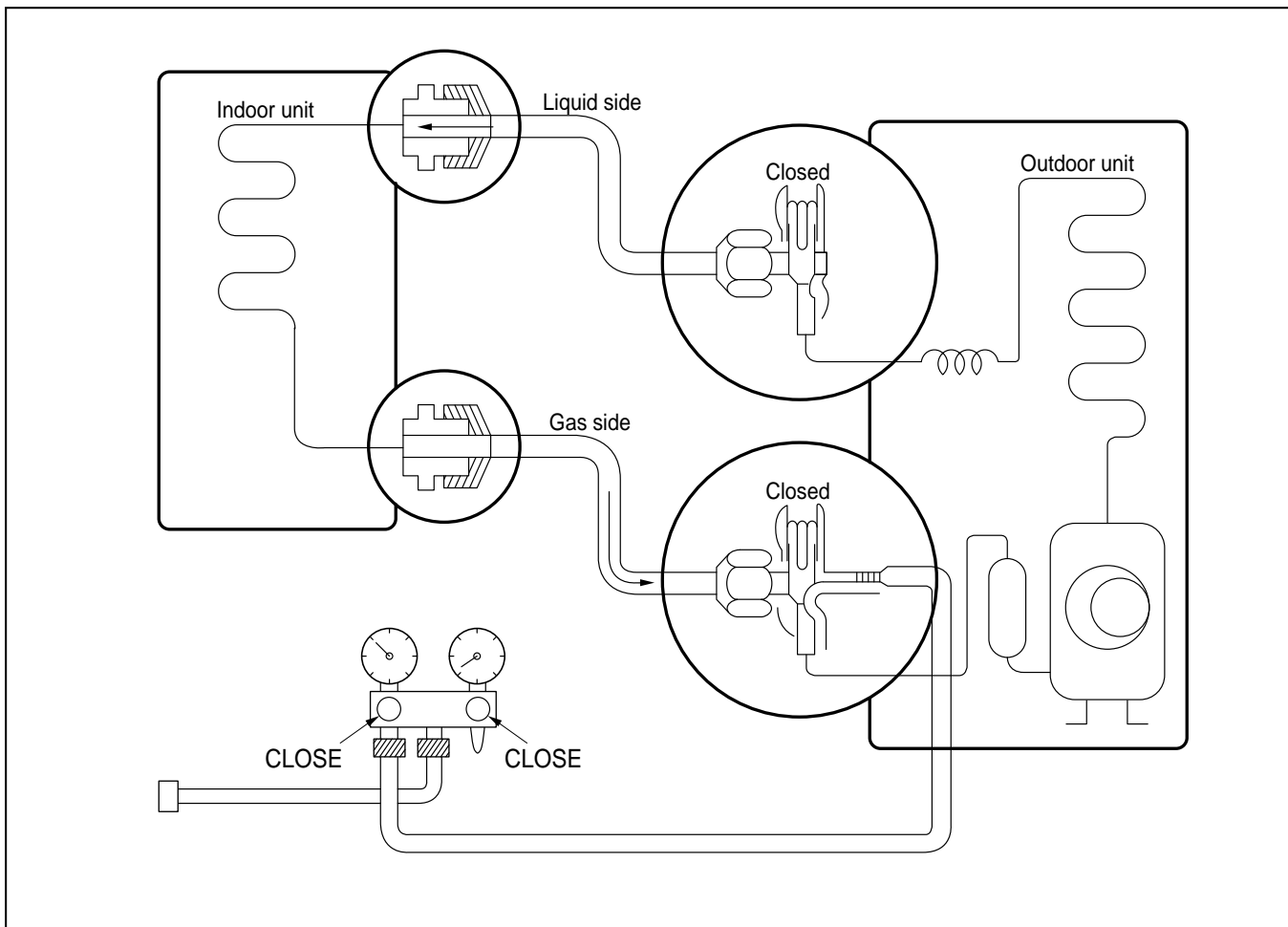



## 5-8. Checking the Drainage and Form the Piping

### 1) Checking the Drainage

- Remove the inlet grille.

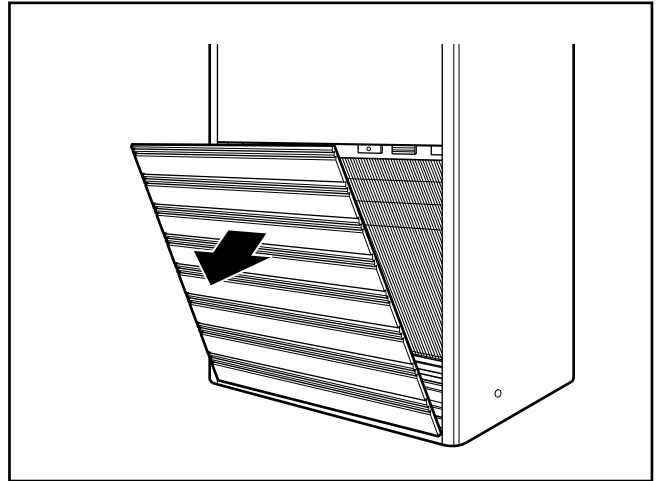

### □ Check the drainage.

- Pour a glass of water into the drain pan.
- Ensure if water flows drain hose of indoor unit.

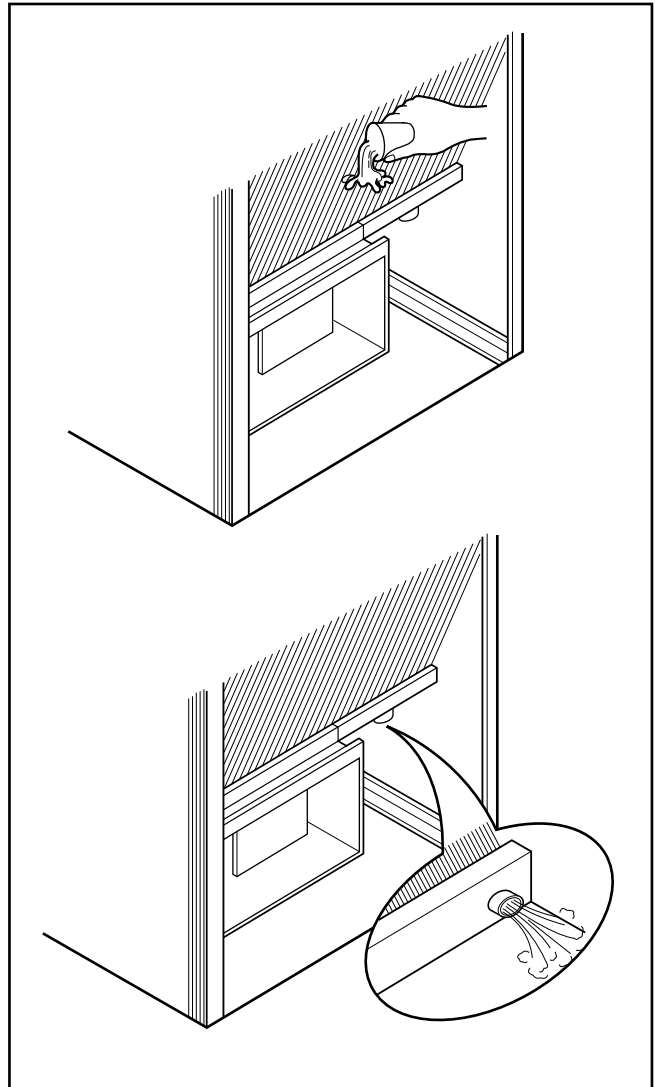

## 2) Form the Piping

- **Wrap the connecting portion of indoor unit with the insulation material and secure it with two Plastic Bands. (for the right piping)**
  - If you connect an additional drain hose, the end of the drain-outlet should be kept distance from the ground. (Do not dip it into water, and fix it on the wall to avoid swinging in the wind.)

**In case of the outdoor unit is installed below position of the indoor unit.**

- **Tape the Piping, and Connecting Cable from down to up.**
- **Form the piping gathered by taping along the exterior wall and fix it onto the wall by saddle or equivalent.**

**In case of the outdoor unit is installed upper position of the indoor unit.**

- **Tape the piping and connecting cable from down to up.**
- **In order to prevent water from entering the room, form a trap and tape the piping.**
- **Fix the piping onto the wall with saddle or bracket.**

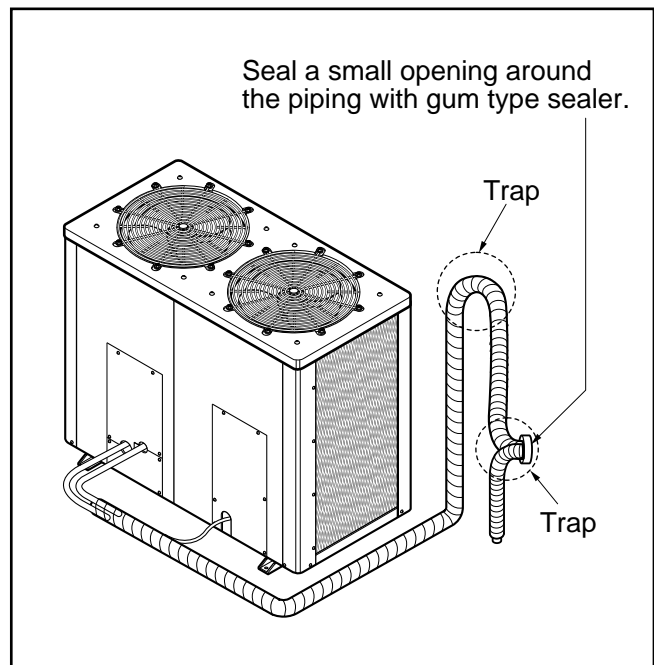
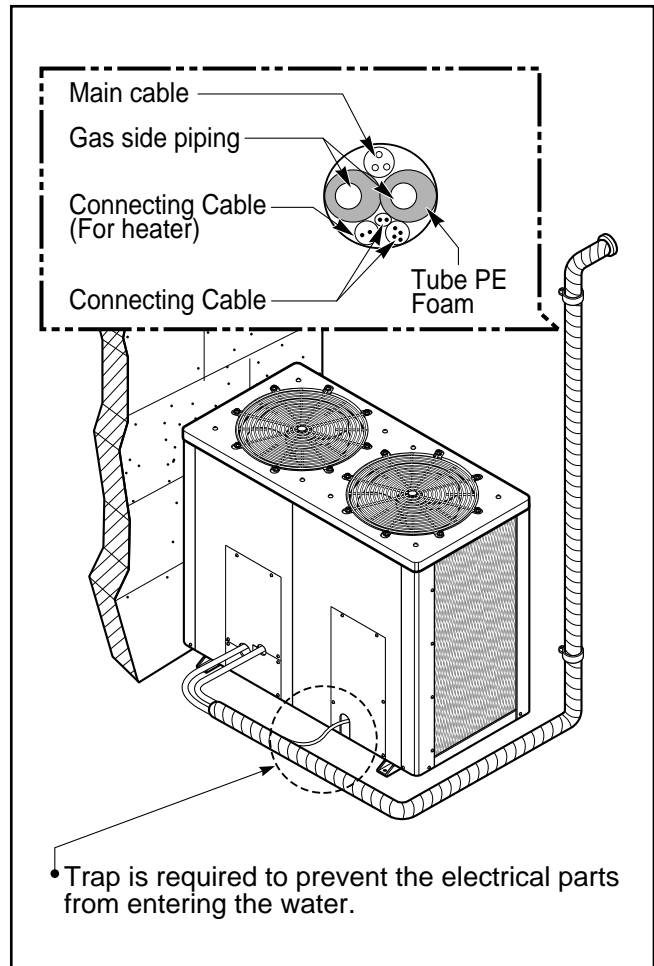

## 5-9 Final Check and Test Run

After installing the unit, perform the final check and running test as follows:

Final check points

- **Is the unit securely mounted?**
- **Is the installation location adequate?**
- **Is the water piping work adequately and without leakage?**
- **Are trapped drain lines installed at condensate drain connections?**
- **Has the refrigeration cooling cycle been kept sealed?**
- **Is the electrical wiring adequate and are the screws tightened on terminals?**

After the above final checkings, prepare the running test as follows:

- **Connect compound gauges to the check joints at discharge and suction sides of the compressor.**
- **Turn all switches "OFF".**
- **Turn the main switch "ON".**

Running test should be accomplished as follows:

- **Set operation switch at "FAN" and the fan will start. Check to ensure that the fan sounds normal.**
- **Next, set it at "COOL" and the compressor will start. Check to ensure that the compressor sounds normal.**
- **Check discharge and suction pressure on the compound gauges.**
- **Check working voltage, phase balance and running current.**
- **Check to ensure that the thermistor functions properly.**
- **Check to ensure that the high pressure control switch functions correctly.**

## 5-10 Installation Check List

### 1. Is the unit securely mounted and levelled?

- Space for Evaporator Air Flow
- Space for Condenser Air Flow
- Space for Maintenance Work
- Noise and Vibration
- Appearance

### 2. Is electrical wiring system adequate?

- Wire Size
- Switch Size
- Fuse Size
- Voltage
- Tightened Connection
- Operation Control Devices
- Safety Devices
- Hz

### 3. Does the refrigerant piping work adequately?

- Pipe Size
- Insulation
- Vibration
- Leakage
- Refrigerant Charge
- Trap

### 4. Does the duct work adequately?

- Pipe Size
- Insulation
- Vibration
- Sound-proof
- Vibration-Proof

### 5. Are the condensate drain lines properly arranged?

- Trap
- Drain Ditch

### 6. Are the service valves opened?

## 5-11 Running Test and Maintenance Record

JOB NUMBER: \_\_\_\_\_

POWER SUPPLY : Main Power \_\_\_\_\_ V, \_\_\_\_\_ Hz

	Indoor Unit	Outdoor Unit
Model	( _____ V, _____ Hz)	( _____ V, _____ Hz)
Production No.		

Accessory Attached : \_\_\_\_\_

CUSTOMER'S NAME AND ADDRESS : \_\_\_\_\_ (PHONE NO.: \_\_\_\_\_ )

INSTALLED BY: \_\_\_\_\_ DATE: \_\_\_\_\_

START UP BY: \_\_\_\_\_ DATE: \_\_\_\_\_

- 1. Does the operation switch function properly?
- 2. Is the rotating direction of the evaporator fan correct?
- 3. Is the rotating direction of the condenser fan correct?
- 4. Is the evaporator airflow sufficient?
- 5. Are there any abnormal sounds?
- 6. Has the unit been operated at least twenty (20) minutes?
- 7. Check indoor temperatures :
  - Inlet : DB \_\_\_\_\_ °C, WB \_\_\_\_\_ °C
  - Outlet : DB \_\_\_\_\_ °C, WB \_\_\_\_\_ °C
- 8. Check outdoor temperatures :
  - Inlet : DB \_\_\_\_\_ °C
  - Outlet : DB \_\_\_\_\_ °C
- 9. Check pressures :
  - Discharge pressure: \_\_\_\_\_ kg/cm<sup>2</sup>
  - Suction pressure: \_\_\_\_\_ kg/cm<sup>2</sup>
- 10. Check voltage :
  - Rated voltage: \_\_\_\_\_ V
  - Operating voltage: R-S \_\_\_\_\_ V, S-T \_\_\_\_\_ V, T-R \_\_\_\_\_ V.
  - Starting voltage: \_\_\_\_\_ V ( $\geq 0.85 \times$  Rated Voltage)
  - Phase unbalance :  $1-V/V$  mean = \_\_\_\_\_ ( $-0.03 \leq \text{Imbalance} \leq +0.03$ )
- 11. Check running current:
  - packaged air conditioner: \_\_\_\_\_ A
- 12. Do the control devices function properly?
- 13. Do the protective devices function correctly?
- 14. Is the refrigerant charge adequate?
- 15. Is the drain line draining properly?
- 16. Is the air filter clean?
- 17. Are the evaporator coil and condenser coil clean?
- 18. Are all cabinet panels fixed?
- 19. Are all cabinet panels free from rattles?

# 6. Operation

## Display

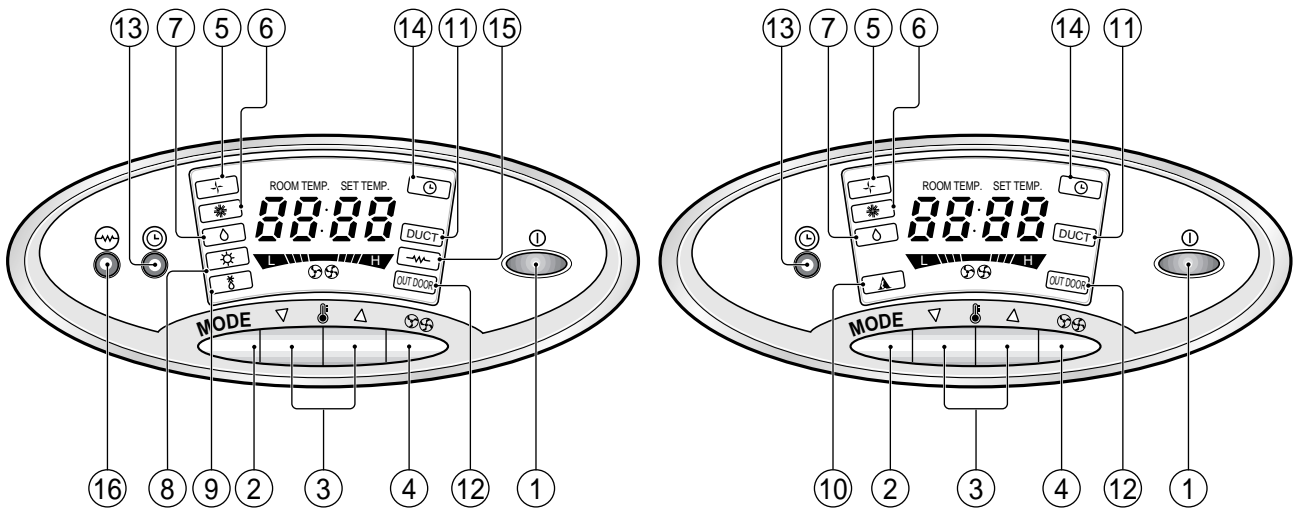

☐ **START/STOP BUTTON**

Operation starts when this button is pressed and stops when the button is pressed again.

☐ **OPERATION MODE SELECTION BUTTON**

Used to select the operation Mode.

☐ **ROOM TEMPERATURE SETTING BUTTONS**

Used to select the room temperature.

☐ **INDOOR FAN SPEED SELECTION**

Used to select fan speed in three steps-low, med, high.

☐ **FAN OPERATION LAMP**

☐ **COOLING OPERATION LAMP**

☐ **SOFT DRY OPERATION LAMP**

☐ **HEATING OPERATION LAMP**

☐ **DEFROST OPERATION LAMP**

☐ **AUTO OPERATION LAMP**

☐ **DUCT AIR FLOW LAMP(OPTION)**

☐ **OUTDOOR UNIT OPERATION LAMP**

☐ **TIMER SETTING BUTTON  
(OPERATION STOPS AT ON)**

☐ **TIMER OPERATION LAMP**

☐ **ELECTRIC HEATER OPERATION LAMP**

☐ **ELECTRIC HEATER OPERATION BUTTON  
(OPTION)**

# 7. 3-Way Valve

		3-Way Valve (Liquid Side)	3-Way Valve (Gas Side)	
Works		Shaft position	Shaft position	Service port
Shipping		Closed (with valve cap)	Closed (with valve cap)	Closed (with valve cap)
1.	Air purging (Installation)	Open (counter-clockwise)	Closed (clockwise)	Open (push-pin)
Operation		Open (with valve cap)	Open (with valve cap)	Closed
2.	Pumping down (transferring)	Open (clockwise)	Open (counter-clockwise)	Open (connected manifold gauge)
3.	Evacuation (Servicing)	Open	Open	Open (with charging cylinder)
4.	Gas charging (Servicing)	Open	Open	Open (with charging cylinder)
5.	Pressure check (Servicing)	Open	Open	Open (with charging cylinder)
6.	Gas releasing (Servicing)	Open	Open	Open (with charging cylinder)

## 7.1 Air purging

Required tools: hexagonal wrench, adjustable wrench, torque wrench, and gas leak detector.

The additional gas for air purging has been charged in the outdoor unit.

However, if the flare connections have not been done correctly and there gas leaks, a gas cylinder and the charge set will be needed.

The air in the indoor unit and in the piping must be purged. If air remains in the refrigeration pipes, it will affect the compressor, reduce cooling capacity, and can lead to a malfunction.

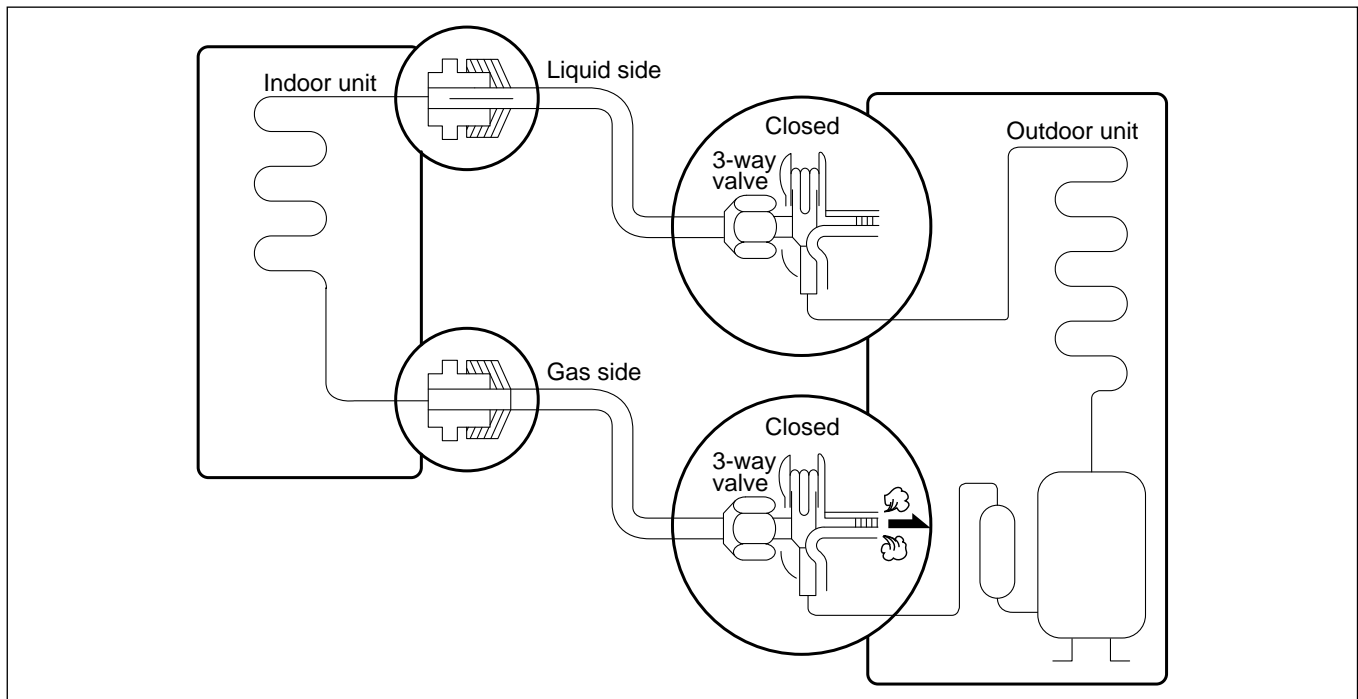

Service port nut.

Be sure, using a torque wrench to tighten the service port nut (after using the service port), so that it prevents the gas leakage from the refrigeration cycle.

### • Procedure

- ☐ Recheck the piping connections.
- ☐ **Open the valve stem of the 3-way(liquid side) valve counterclockwise approximately 90°, wait 10 seconds, and then set it to closed position.**
  - Be sure to use a hexagonal wrench to operate the valve stem.
- ☐ **Check for gas leakage.**
  - Check the flare connections for gas leakage.
- ☐ **Purge the air from the system.**
  - Set the 3-way(liquid side) valve to the open position and remove the cap from the 3-way(gas side) valve's service port.
  - Using the hexagonal wrench to press the valve core pin, discharge for three seconds and then wait for one minute. Repeat this three times.
- ☐ **Use torque wrench to tighten the service port nut.**
- ☐ **Set the 3-way (gas side) valve to the back seat.**
- ☐ **Mount the valve stem nuts to the 3-way (liquid side) valve and 3-way (gas side) valves.**
- ☐ **Check for gas leakage.**
  - At this time, especially check for gas leakage from the 3-way (liquid side) valve and 3-way (gas side) valve's stem nuts, and from the service port nut.

### Caution

**If gas leakage is discovered in step ☐ above, take the following measures:**

If the gas leaks stop when the piping connections are tightened further, continue working from step ☐. If the gas leaks do not stop when the connections are retightened, repair the location of the leak, discharge all of the gas through the service port, and then recharge with the specified amount of gas from a gas cylinder.



## 7.2 Pump down

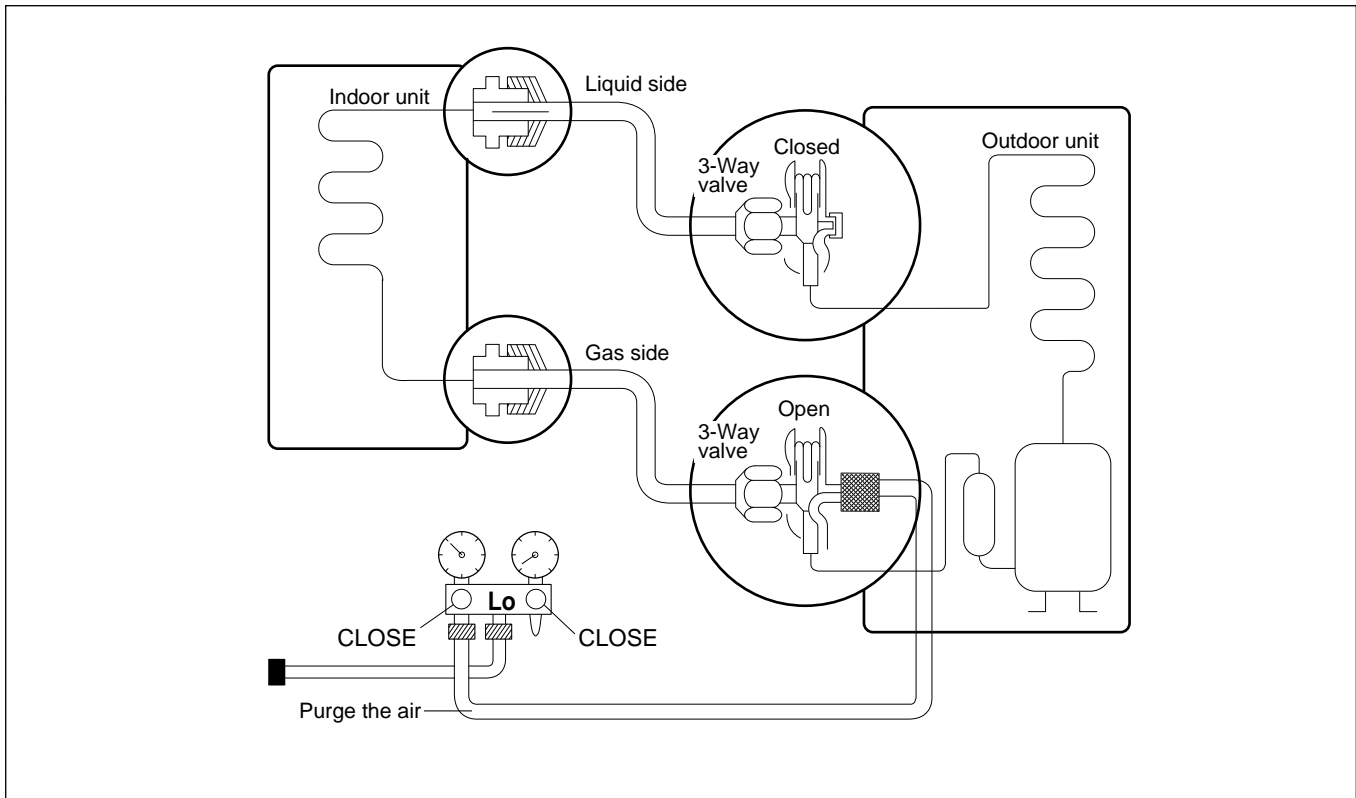

### • Procedure

- **Confirm that both 3-way(liquid side) and 3-way(gas side) valves are set to the open position.**
  - Remove the valve stem caps and confirm that the valve stems are in the raised position.
  - Be sure to use a hexagonal wrench to operate the valve stems.
- **Operate the unit for 10 to 15 minutes.**
- **Stop operation and wait for 3 minutes, then connect the charge set to the service port of the 3-way (gas side) valve.**
  - Connect the charge hose with the push pin to the service port.
- **Air purging of the charge hose.**
  - Open the low-pressure valve on the charge equipment slightly to purge air from the charge hose.
- **Set the 3-way(liquid side) valve to the closed position.**
- **Operate the air conditioner at the cooling cycle and stop it when the gauge indicates 1 kg/cm<sup>2</sup>g**
- **Immediately set the 3-way(gas side) valve to the closed position.**
  - Do this quickly so that the gauge ends up indicating 3 to 5kg/cm<sup>2</sup>g.
- **Disconnect the charge set, and mount the 3-way(liquid side) and 3-way(gas side) valve's stem nuts and the service port nut.**
  - Use torque wrench to tighten the service port nut.
  - Be sure to check gas leakage.

## 1) Re-airpurging (Re-installation)

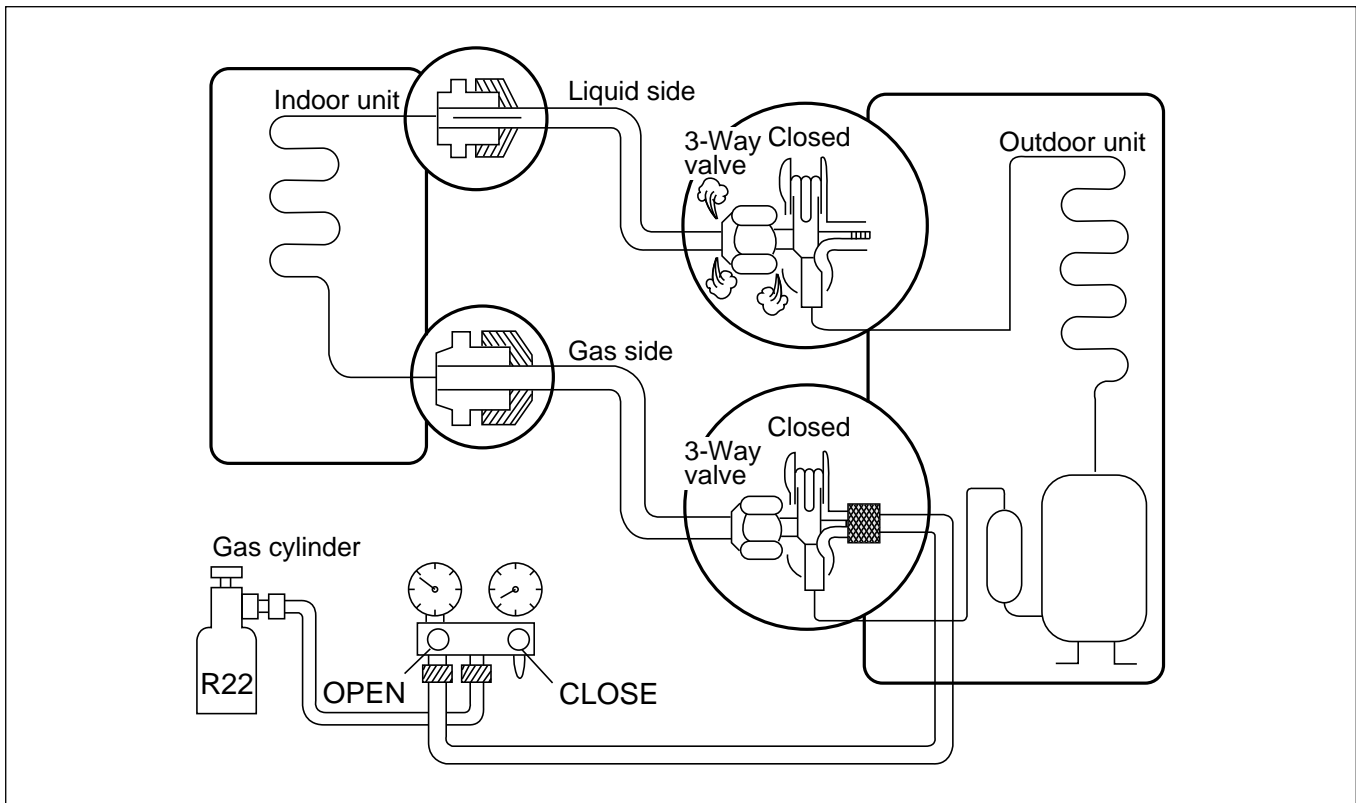

### • Procedure

- ☐ **Confirm that both the 3-way (liquid side) valve and the 3-way(gas side) valve are set to the closed position.**
- ☐ **Connect the charge set and a gas cylinder to the service port of the 3-way(gas side) valve.**
  - Leave the valve on the gas cylinder closed.
- ☐ **Air purging.**
  - Open the valves on the gas cylinder and the charge set. Purge the air by loosening the flare nut on the 3-way(liquid side) valve approximately 45° for 3 seconds then closing it for 1 minute; repeat 3 times.
  - After purging the air, use a torque wrench to tighten the flare nut on liquid side valve.
- ☐ **Check gas leakage.**
  - Check the flare connections for gas leakage.
- ☐ **Discharge the refrigerant.**
  - Close the valve on the gas cylinder and discharge the refrigerant until the gauge indicates 3 to 5kg/cm<sup>2</sup>g
- ☐ **Disconnect the charge set and the gas cylinder, and set the 3-way(liquid side) and 3-way(gas side) valves to the open position.**
  - Be sure to use a hexagonal wrench to operate the valve stems.
- ☐ **Mount the valve stem nuts and the service port nut.**
  - Use torque wrench to tighten the service port nut.
  - Be sure to check gas leakage.

## 2) Balance refrigerant of the 3-way(liquid side), 3-way(gas side) valves (Gas leakage)

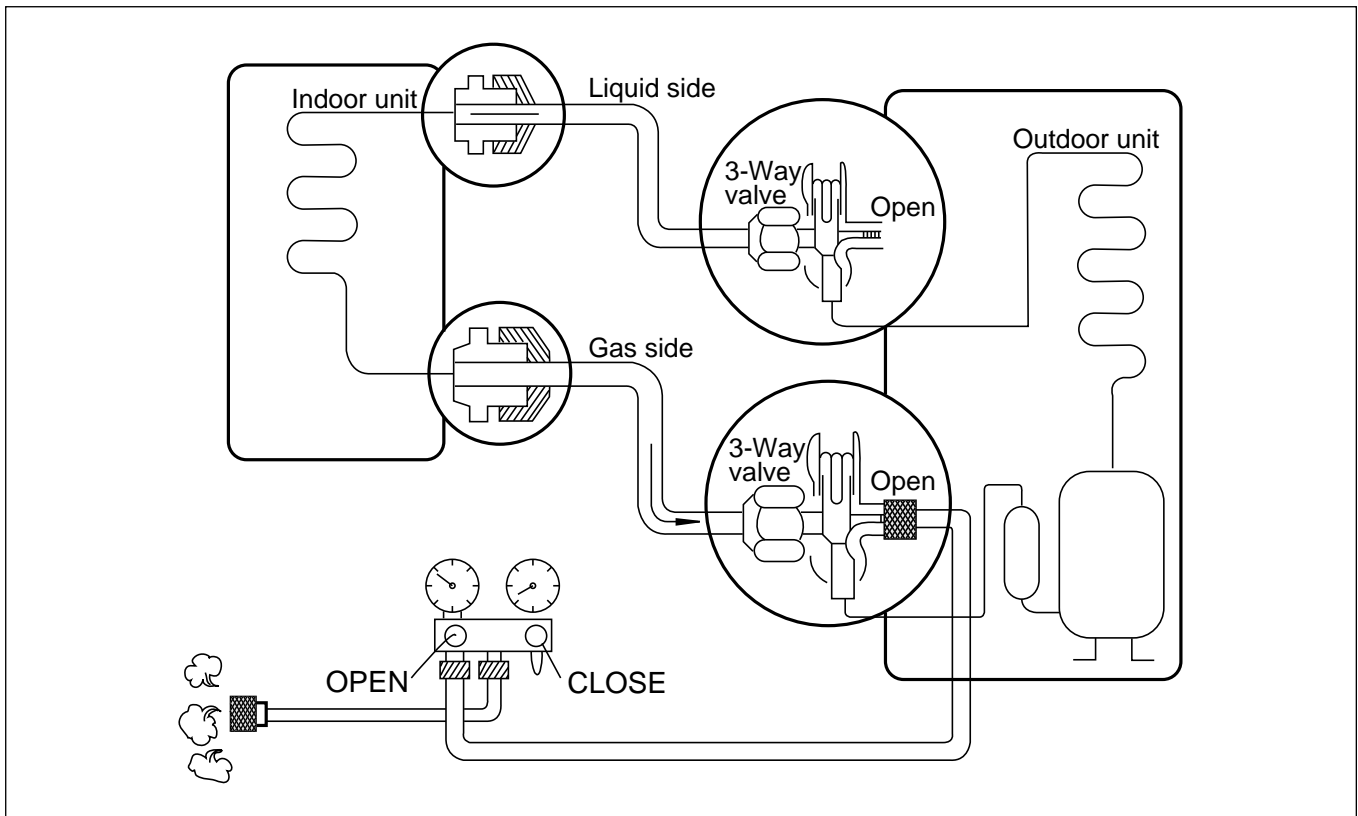

### • Procedure

- Confirm that both the liquid side and gas side valves are set to the back seat.
- **Connect the charge set to the 3-way(gas side) valve's port.**
  - Leave the valve on the charge set closed.
  - Connect the charge hose with the push pin to the service port.
- **Open the valve (Lo side) on the charge set and discharge the refrigerant until the gauge indicates 0 kg/cm<sup>2</sup>g.**
  - If there is no air in the refrigerant cycle (the pressure when the air conditioner is not running is higher than 1 kg/cm<sup>2</sup>g), discharge the refrigerant until the gauge indicates 0.5 to 1 kg/cm<sup>2</sup>g. In case of this, it will not be necessary to apply an evacuation.
  - Discharge the refrigerant gradually; if it is discharged too suddenly, the refrigeration oil will also be discharged.

## 7.3 Evacuation

(All amount of refrigerant leaked)

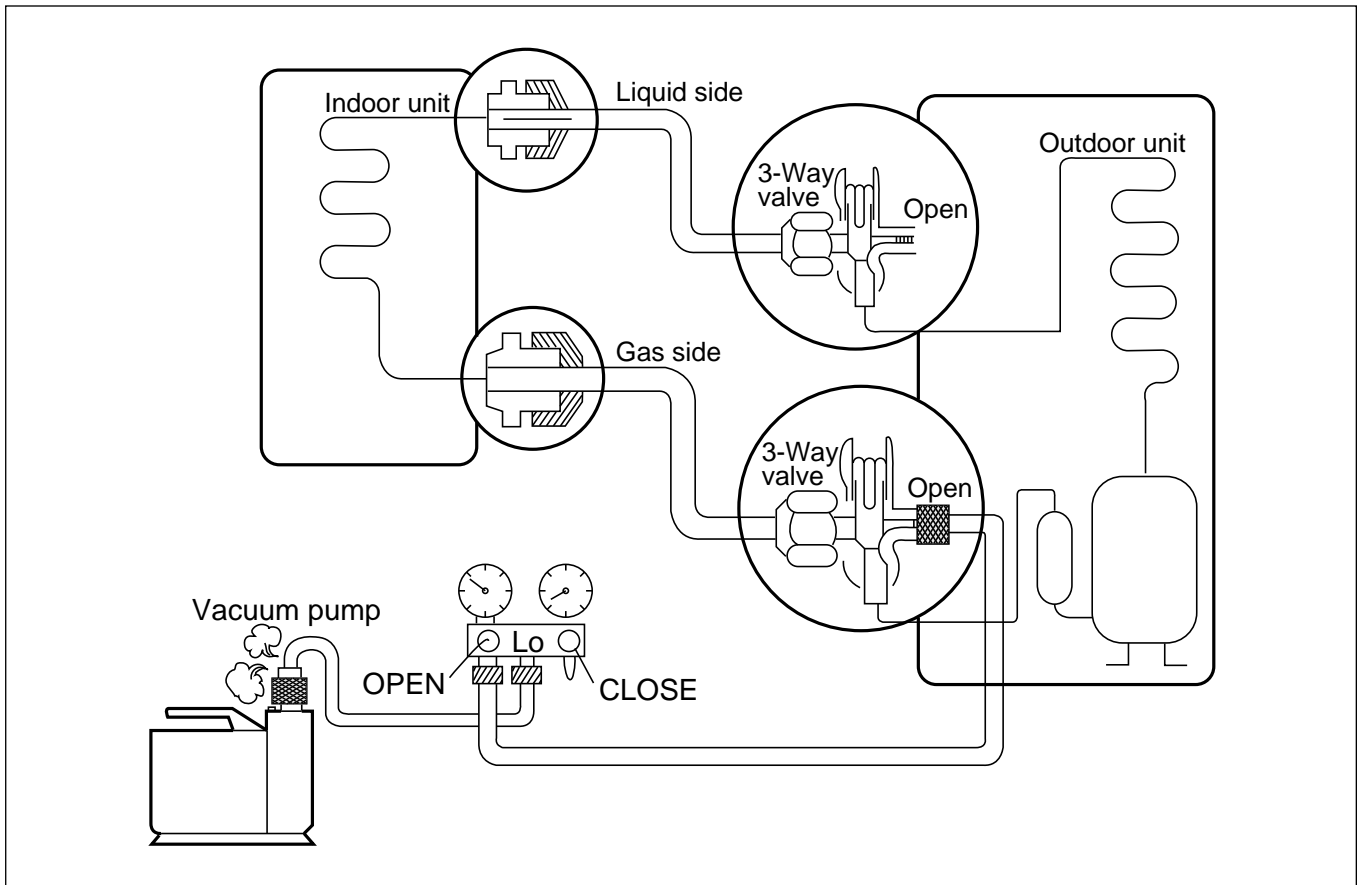

### • Procedure

- Connect the vacuum pump to the center hose of charge set.
- **Evacuation for approximately one hour.**
  - Confirm that the gauge needle has moved toward -76cmHg (vacuum of 4 mmHg or less).
- **Close the valve (Lo side) on the charge set, turn off the vacuum pump, and confirm that the gauge needle does not move (approximately 5 minutes after turning off the vacuum pump).**
- **Disconnect the charge hose from the vacuum pump.**
  - Vacuum pump oil.
  - If the vacuum pump oil gets dirty or depleted, replenish as needed.

## 7.4 Gas Charging

### 1) Cooling mode (After Evacuation)

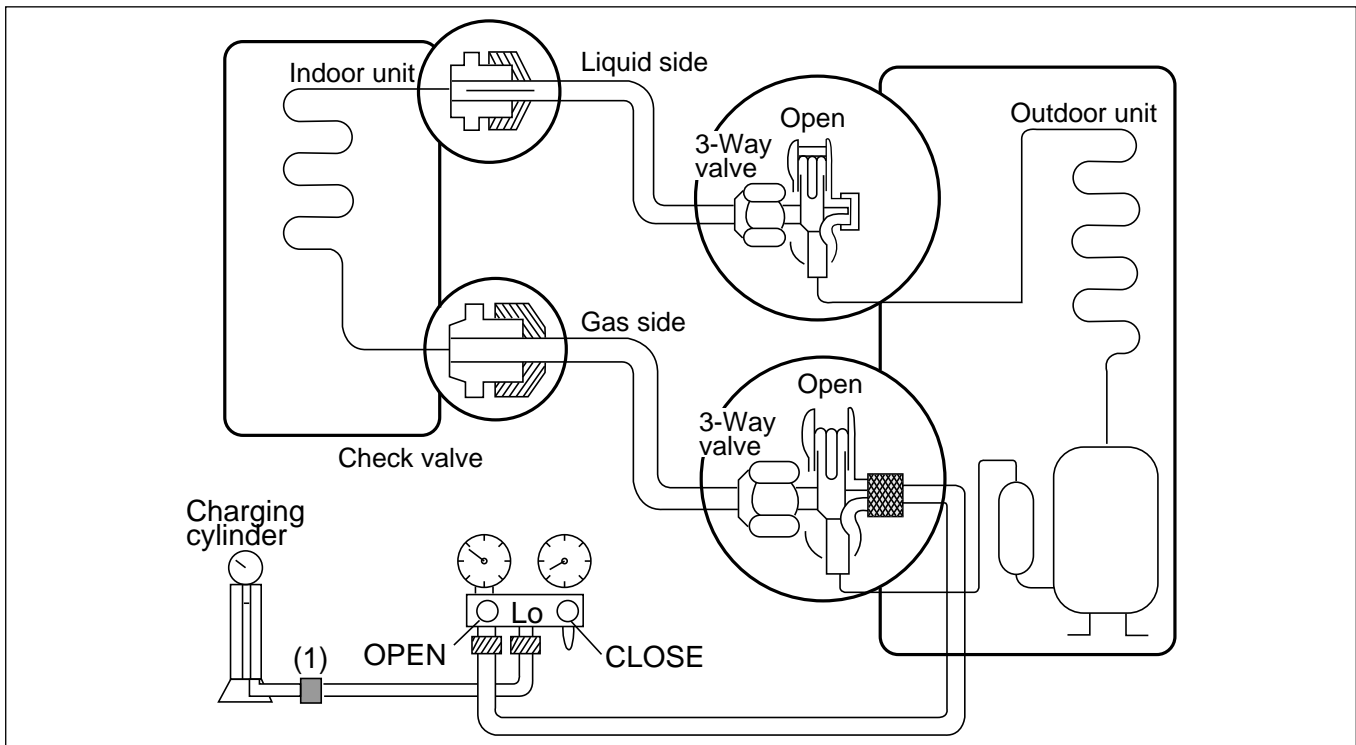

#### • Procedure

##### □ Connect the charge hose to the charging cylinder.

- Connect the charge hose which you disconnected from the vacuum pump to the valve at the bottom of the cylinder.
- If you are using a gas cylinder, use a scale and reverse the cylinder so that the system can be charged with liquid.

##### □ Purge the air from the charge hose.

- Open the valve at the bottom of the cylinder and press the check valve on the charge set to purge the air. (Be careful of the liquid refrigerant). The procedure is the same if using a gas cylinder.

##### □ Open the valve (Lo side) on the charge set and charge the system with liquid refrigerant.

- If the system can not be charged with the specified amount of refrigerant, it can be charged with a little at a time (approximately 150g each time) while operating the air conditioner in the cooling cycle; however, one time is not sufficient, wait approximately 1 minute and then repeat the procedure (pumping down-pin).

This is different from previous procedures. Because you are charging with liquid refrigerant from the gas side, absolutely do not attempt to charge with larger amounts of liquid refrigerant while operating the air conditioner.

##### □ Immediately disconnect the charge hose from the 3-way(gas side) valve's service port.

- Stopping partway will allow the gas to be discharged.
- If the system has been charged with liquid refrigerant while operating the air conditioner turn off the air conditioner before disconnecting the hose.

##### □ Mount the valve stem nuts and the service port nut.

- Use a torque wrench to tighten the service port nut.
- Be sure to check gas leakage.

## 2) Heating Mode (After Evacuation)

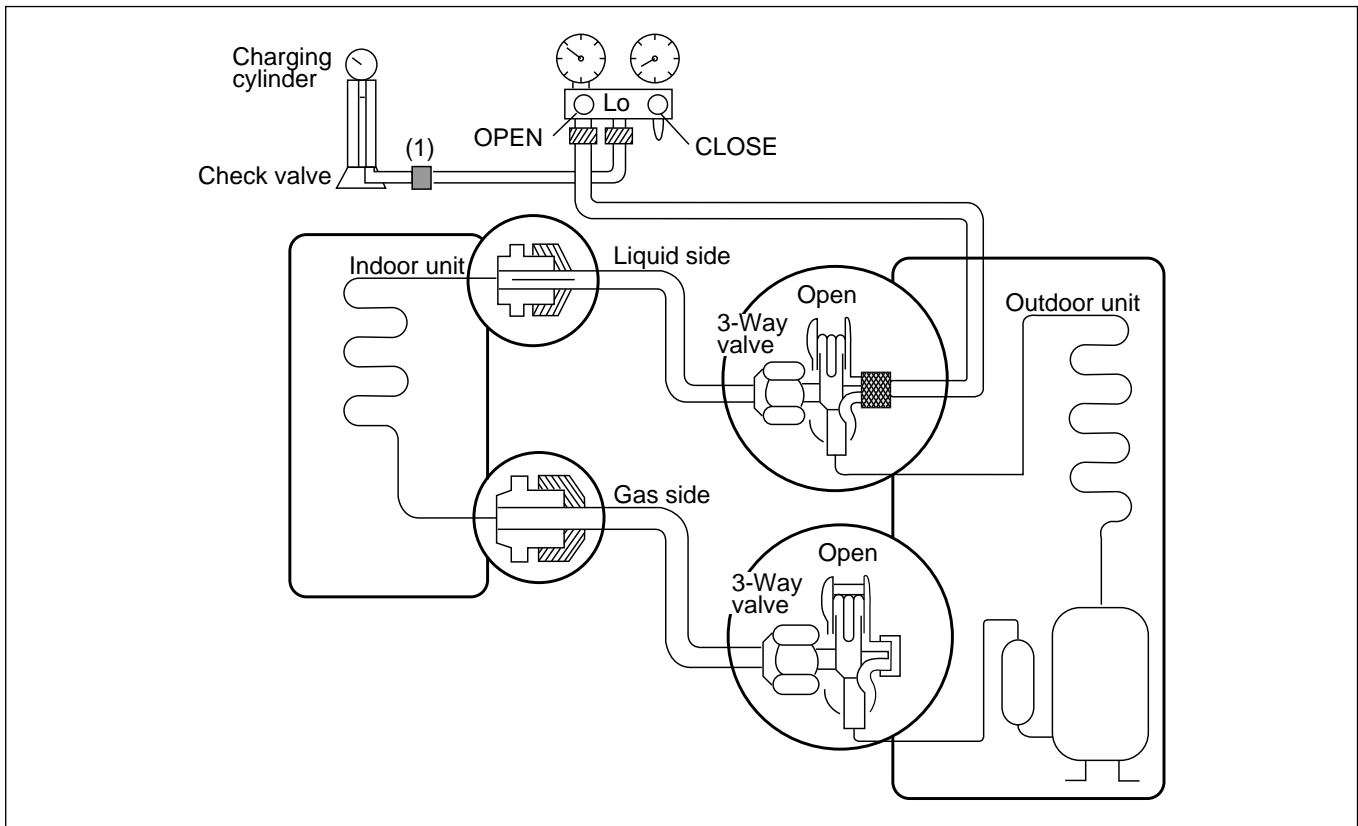

### • Procedure

#### □ Connect the charge hose to the charge cylinder.

- Connect the charge hose which you disconnected from the vacuum pump to the valve at the bottom of the cylinder.
- If you are using a gas cylinder, use a scale and reverse the cylinder so that the system can be charged with liquid.

#### □ Purge the air from the charge hose.

- Open the valve at the bottom of the cylinder and press the check valve on the charge set to purge the air. (Be careful of the liquid refrigerant). The procedure is the same if using a gas cylinder.

#### □ Open the valve (Lo side) on the charge set and charge the system with liquid refrigerant.

- If the system can not be charged with the specified amount of refrigerant, it can be charged with a little at a time (approximately 150g each time) while operating the air conditioner in the cooling cycle; however, one time is not sufficient, wait approximately 1 minute and then repeat the procedure (pumping down-pin).

This is different from previous procedures. Because you are charging with liquid refrigerant from the gas side, absolutely do not attempt to charge with larger amounts of liquid refrigerant while operating the air conditioner.

#### □ Immediately disconnect the charge hose from the 3-way valve's service port.

- Stopping partway will allow the gas to be discharged.
- If the system has been charged with liquid refrigerant while operating the air conditioner turn off the air conditioner before disconnecting the hose.

#### □ Mount the valve stem nuts and the service port nut.

- Use a torque wrench to tighten the service port nut.
- Be sure to check gas leakage.

# 8. Troubleshooting Guide

In general, possible trouble is classified as two causes.

The one is so called **Starting Failure** which is caused from an electrical defect, and the other is **Ineffective Air Conditioning** caused by a defect in the refrigeration circuit and improper application.

## Unit runs but ineffective cooling

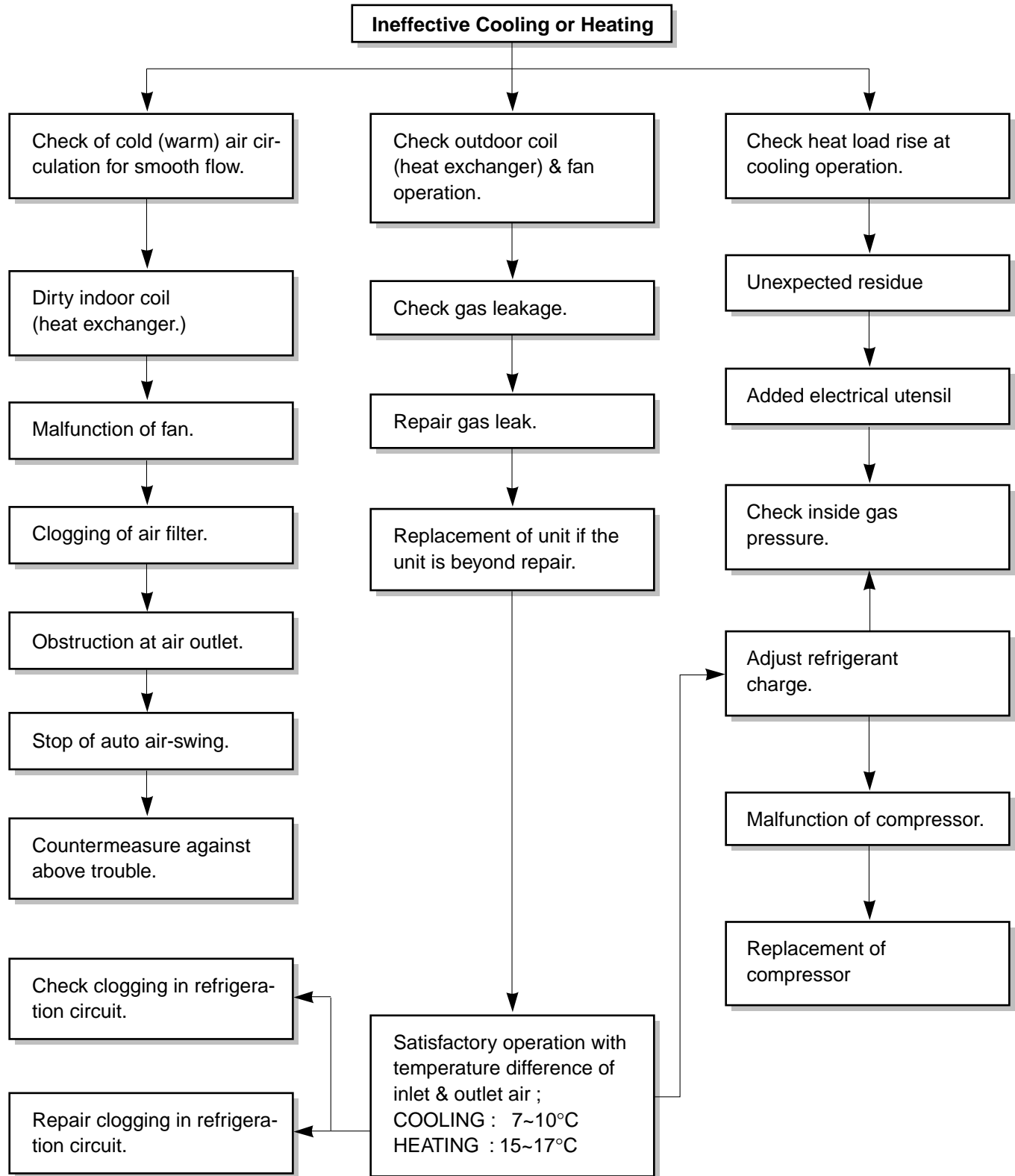

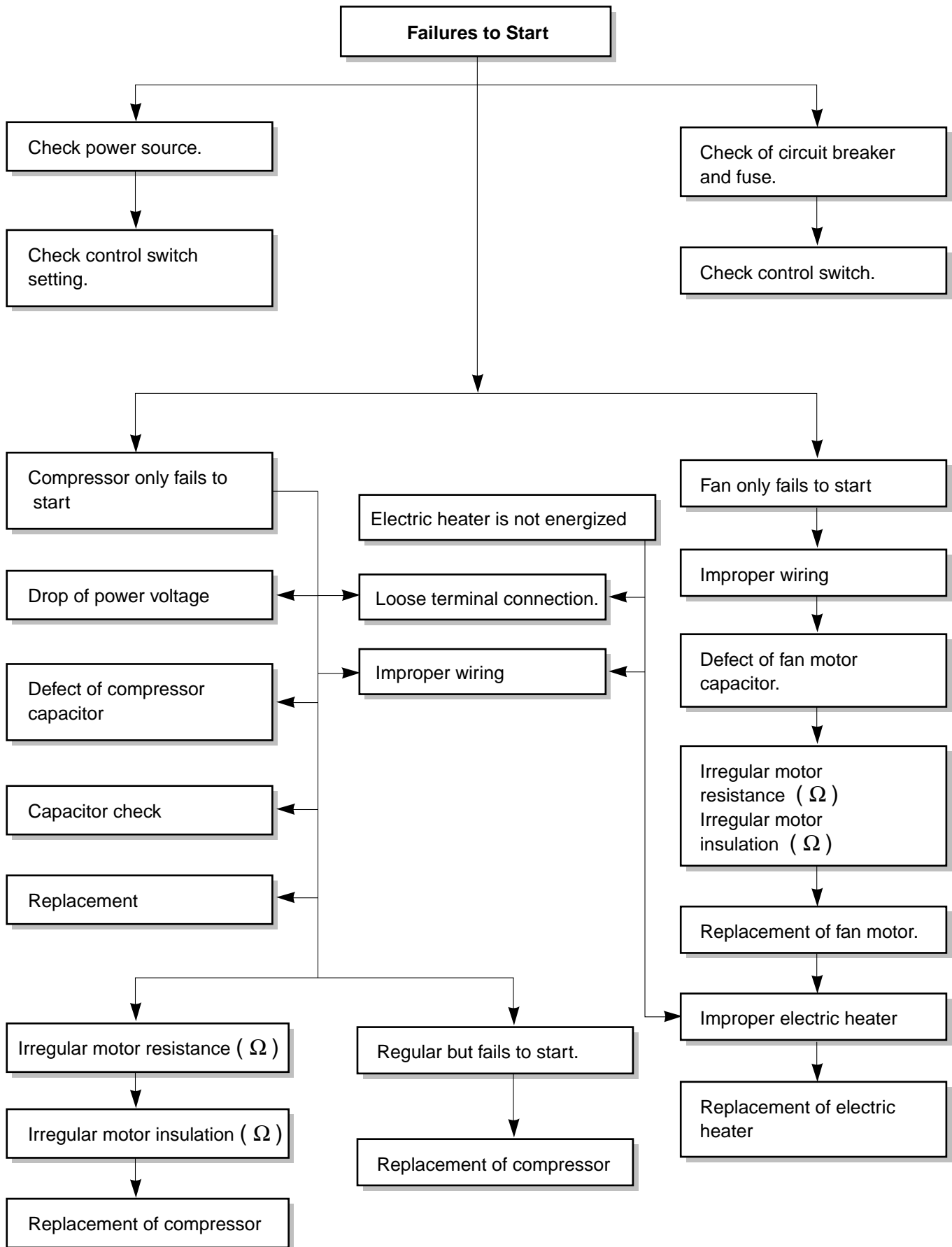



## PACKAGE AIR CONDITIONER VOLTAGE LIMITS

NAME PLATE RATING	MINIMUM	MAXIMUM
380 - 415 V	342 V	456 V

### 8.1 No cooling and heating operation performed

#### 1) Both the blower and the compressor do not work

WHAT TROUBLED	COMPLAINTS	HOW TO CHECK	REMEDY
Other parts than the unit	Electric supply interrupted Defective power wiring Cut of power fuse	Measure it with a tester in case that the same power source is supplied to other equipment than the unit, what and where trouble can be discovered by checking the operation of other equipment.	Repair a switch box and is relative instrument. Replacement of fuse Request a power supplier to repair.
	Too low voltage	Measure it with a tester.	Check the power source. Use a thick cable if necessary.
Magnetic switch for compressor & fan motor	Control point is on condition of "OFF" due to trouble.	Make short-circuit, then measure it with a tester.	Replace it if necessary.
Operating switch	Troubled or defective contactor	Check it with the eyes or tester.	Repair or replace it.
Protection devices	Opened the contact point with trouble	Check it with the eyes or tester.	Discover the trouble cause and push the rest button.

#### 2) Only blowers do not work

WHAT TROUBLED	COMPLAINTS	HOW TO CHECK	REMEDY
Air volume change over switch	Troubled or defective contact point	Check it with the eyes or a tester	Repair or replace it.
Capacitor	Defected	Check it with a tester.	Replace it.

### 3) Only outdoor fan does not work

WHAT TROUBLED	COMPLAINTS	HOW TO CHECK	REMEDY
Motor	Over-heated Layer short	Check how it is insulated.	Repair or replace it.
Electric Wiring	Open wire on operation	Check it with a tester.	Rewiring or repair.
	Short circuited on operation		

### 4) Only compressor does not work

WHAT TROUBLED	COMPLAINTS	HOW TO CHECK	REMEDY
Magnetic switch for compressor motor	Defective contact, magnetic coil troubled.	Check it with the eyes on with a tester.	Repair or replace it.
Compressor motor	Troubled over-heated (layer short)	Check how it is insulated.	Replace or repair the compressor.
Compressor	Troubled or over-heated (lock)	Groaned noise of motor	Repair or replace it.
High pressure switch	Troubled or defective contact or operating	Check it with a tester.	Replace it if necessary.
Electric circuit	Defective connection or disconnection of the circuit for compressor.	Check it with a tester.	Rewiring or push reset button.

## 8.2 The Units discontinue after the operation started

WHAT TROUBLED	COMPLAINTS	HOW TO CHECK	REMEDY
Other parts than the unit	Improper opening of the service valves in the refrigerant line	Checking	Open it properly
Outdoor coil	Coil is dirty *1	Checking	Wash it by means of something like chemical washing.
In-condensable gas blended.	Air intruded into the refrigerant pipe line *1	In the event that difference between the saturating temperature corresponding to high pressure and the temperature of air discharged from the outdoor coil is more than 15°C, incondensable gas may be blended.	Extract air by vacuum pump, then recharge the refrigerant.
High pressure switch	Improper adjustment	Check it with a pressure gauge.	Readjust it to normal operating pressure. (Note) Don't alternate the specified adjusting pressure. If the adjusted pressure exceeds the specified range, it will cause a great accident.
Refrigerant	A shortage of refrigerant amount. * 2		Recharge the refrigerant. Repair the spot where it leaks.
Outdoor Fan	Reverse rotation of fan Obstacle Air short circuit *1	Confirm the wind blowing out. Check it with eyes.	If reversed, connect interchanged wires to each terminal. Power wirings.

**Note:** Use an appropriate measuring instrument for readjustment.

\*1: Check the High-pressure switch indication.

\*2: Check the Low- pressure switch indication.

### 8.3 The unit is working, but not cooling and heating sufficiently (Both blower and compressor are working)

WHAT TROUBLED	COMPLAINTS	HOW TO CHECK	REMEDY
Load	Much heat load	Heat load increased. Window or door has many cracks or gaps.	Do necessary disposal respectively.
Air flow	Obstacle disturbs Intake of uniform wind.	Checking	Correct it.
Short air volume	Reverse rotation of blower.	Checking	Correct it.
Refrigerant	Shortage in the charged refrigerant.	Coil inlet pipe is frosted	Replenish it. (Repair the leakage spot).
Air passage	Improper or foreign bodies	Checking	Correct or clear the foreign bodies.
Air filter	Clogged with dust	Checking	Cleaning

### 8.4 All the functions are performed normally, but very noisily and much vibratively.

WHAT TROUBLED	COMPLAINTS	HOW TO CHECK	REMEDY
Compressor	Liquid refrigerant flooding back from the evaporator.	<ul style="list-style-type: none"> <li>• Check for refrigerant over-charge.</li> <li>• Check to see if the intaking air temperature is extremely cold.</li> <li>• Check for insufficient air flow quantity.</li> </ul>	
	Compressor shipping bracket is not removed.	• Checking	• Remove the shipping bracket.
	Faulty discharge valve and suction valve.	• Checking	• Replace the compressor
Blower	Fan broken. Other materials intruded.	Checking	<ul style="list-style-type: none"> <li>• Repair or replace it.</li> <li>• Clear the other material</li> </ul>
Screws	Looseness or fail-off of screws	Checking	Repair

WHAT TROUBLED	COMPLAINTS	HOW TO CHECK	REMEDY
Electric troubles (Magnetic contactor)	Defective contact. Defective contact point. Rusting and faults in the iron core contact face. Defective contact of the operating switch.	Checking	Repair and clean or replace it.
Others	Improper installation	Checking	Correct it.

## 8.5 Trouble checking by protection devices

Fault	Cause	Check/Corrective Action
High Discharge	Condenser cooling air extremely hot or insufficient air flow through the condenser	1. Check the operation of the outdoor motor. 2. Check discharge and suction, air circulation.
	Inside of the condenser tube is clogged.	Clean condenser coil.
	Air in the refrigeration cooling cycle.	Purge air from the cycle.
	Suction pressure is higher than standard.	See "High Suction Pressure".
Low Discharge	Faulty discharge valves or suction valves of the compressor.	1. Check unit operation input 2. Check the suction pressure.
	Refrigerant low-charge or leakage.	Add refrigerant: repair leakage if any.
	Suction pressure is lower than standard.	See "Low Suction Pressure".
High Suction Pressure	Intake air extremely hot or excessive air flow through the evaporator coil.	1. Check fresh air, intake or check for leakage of the return air. 2. Check air flow quantity.
	Refrigerant over-charge.	Purge the refrigerant.
	Faulty discharge valve or suction valve of the compressor.	Check the operating input.
	Discharge pressure is higher than standard	See "High discharge Pressure".
Low Suction Pressure	Intake air extremely cold or insufficient air flow through the evaporator coil.	1. Check air flow quantity. 2. Check air filter. 3. Check evaporator coil frosting
	Refrigerant short-charge or leakage.	Add refrigerant, repair leakage, if any.
	Restricted liquid in the suction line.	Check the capillary tube and the strainer.

<b>Fault</b>	<b>Cause</b>	<b>Check/Corrective Action</b>
	Discharge pressure is lower than standard.	See "Low Discharge Pressure".
	Single or three phases running.	Check the power supply line and the contactor.
	High or low voltage or phase unbalance.	Check the voltage and phase unbalance.
Internal Thermostat Cut-Off	Refrigerant short charge or leakage.	Add refrigerant, repair leakage, if any.
	Compressor frequently stops and starts.	Check thermistor operation, or any other cause for frequent stop and start operation.
	Discharge and suction pressure are extremely high.	See "High Discharge Pressure" or "High Suction Pressure".
Overcurrent Relay for Compressor Cut-Off	High or low voltage, or phase unbalance.	Check the voltage and phase unbalance.
	Single or three phases running	Check the power supply line and the contact.
	Faulty compressor motor.	Check electric resistance among the compressor terminals, and from the terminals to ground.
	Loose connections.	Check the electric connections.
	Compressor frequently stops and starts.	Check the operation of the thermistor, or any other cause for frequent stop.
Overcurrent Relay for Fan Motor Cut-Off	High or low voltage, or phase unbalance.	Check the voltage and electric wiring.
	Single or three phases running.	Check the power supply line and the contactor.
	Faulty fan motor.	Check the fan motor and wiring.
	Loose connection.	Check the electric connections.
	Faulty fan bearing.	Check repair or replace the bearing.
Fuse Blown	Loose connections.	Check the electric connections.
	Single or three phase running.	Check the power supply line.
	Faulty motor.	Check electric resistance among motor housing, and from the terminals to ground.
Disconnection and Faulty Contact	Disconnection.	1. Check the wires and connect where necessary. 2. Check the contact holding coil.
	Faulty contact.	Check the contact in the magnetic contact, the over-current relay, the pressure control switch, the operation switch, the auxiliary relay.

## 8.6 Electronic Parts Troubleshooting Guide

### 1) No cooling operation performed.

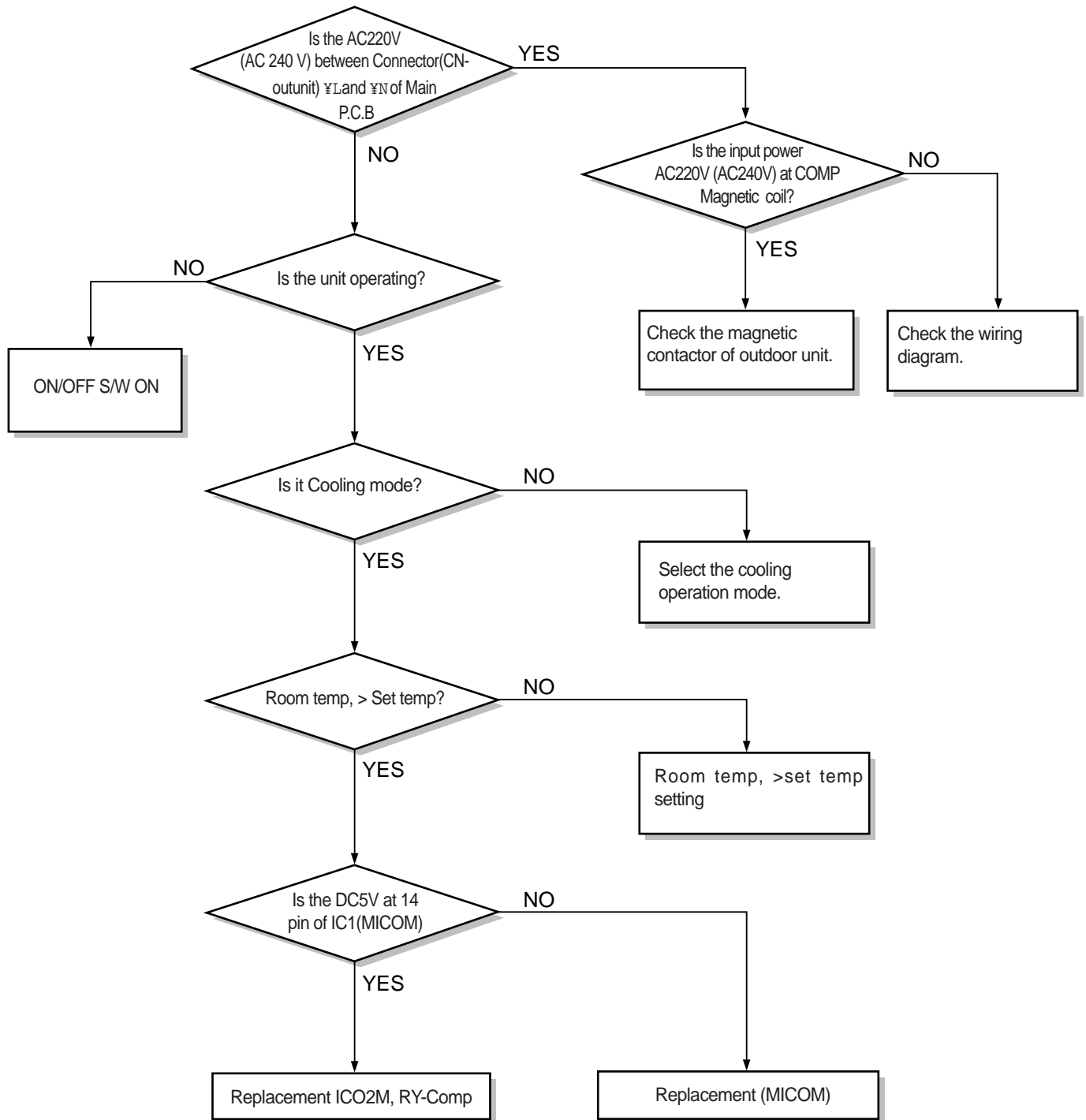

## 2) Indoor fan does not operate.

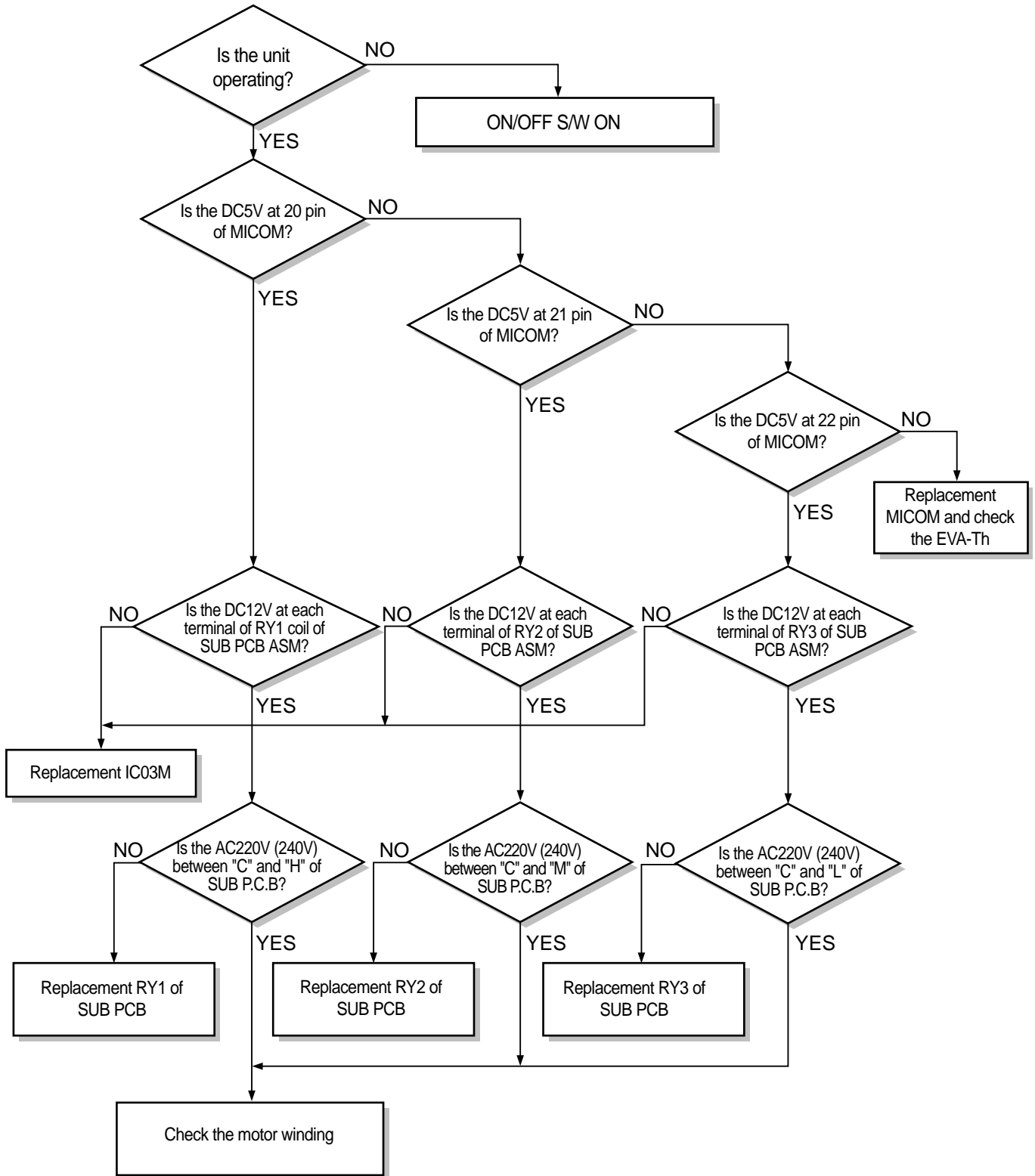



**3) The unit does not operate.**

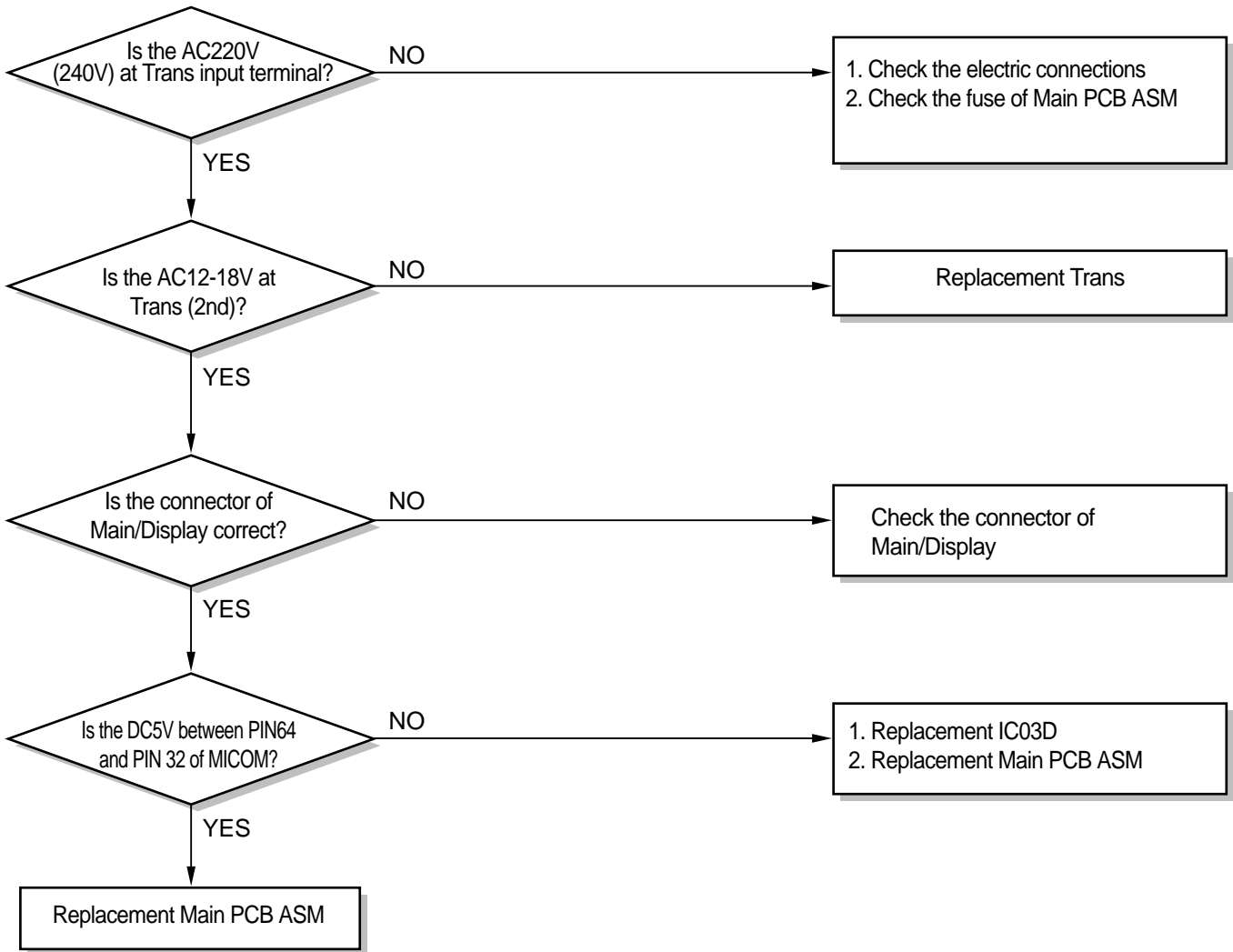

**4) Timer control does not operate.** — Replacement MICOM

#### 4) No heating operation performed.

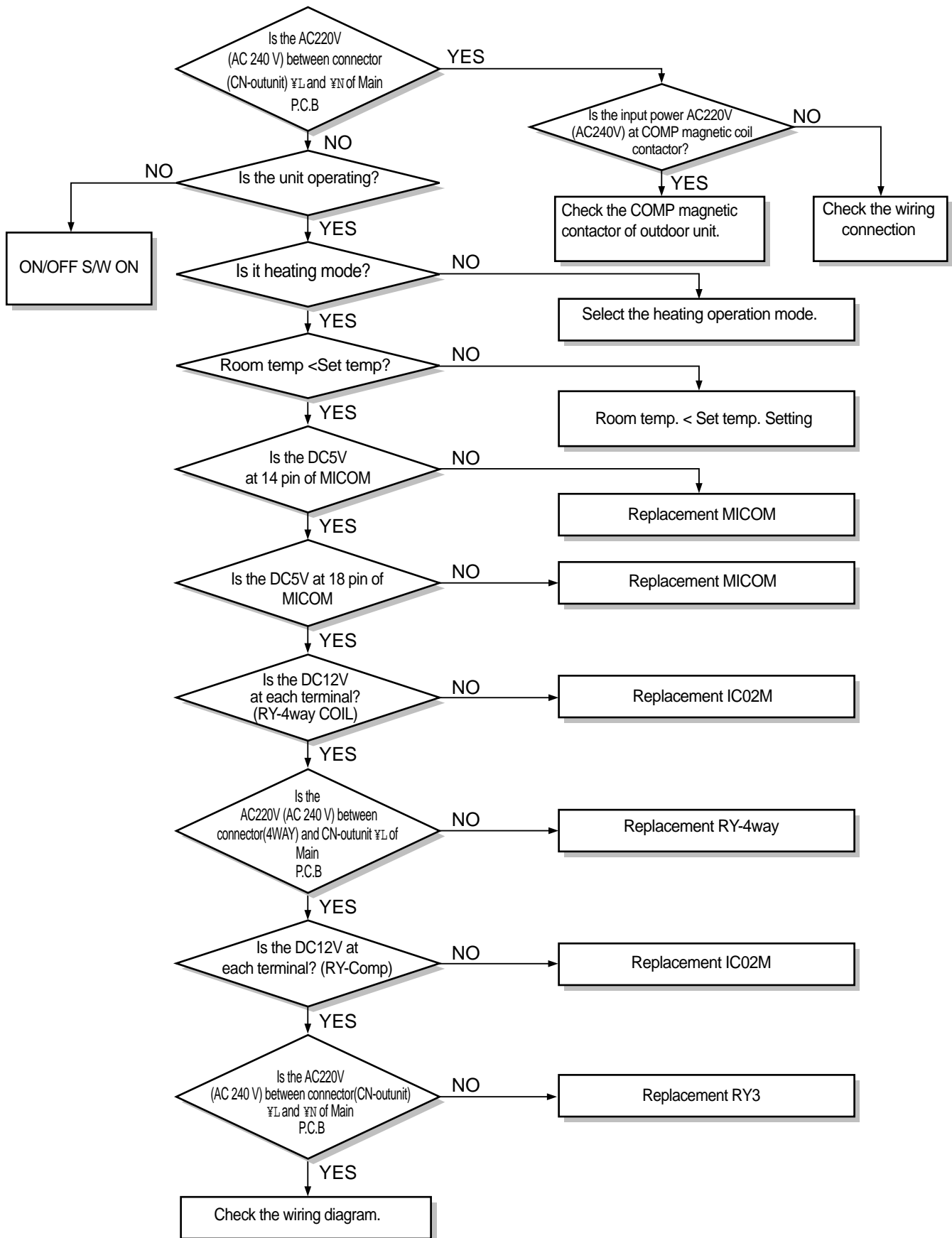

### 5) No heater operation performed.

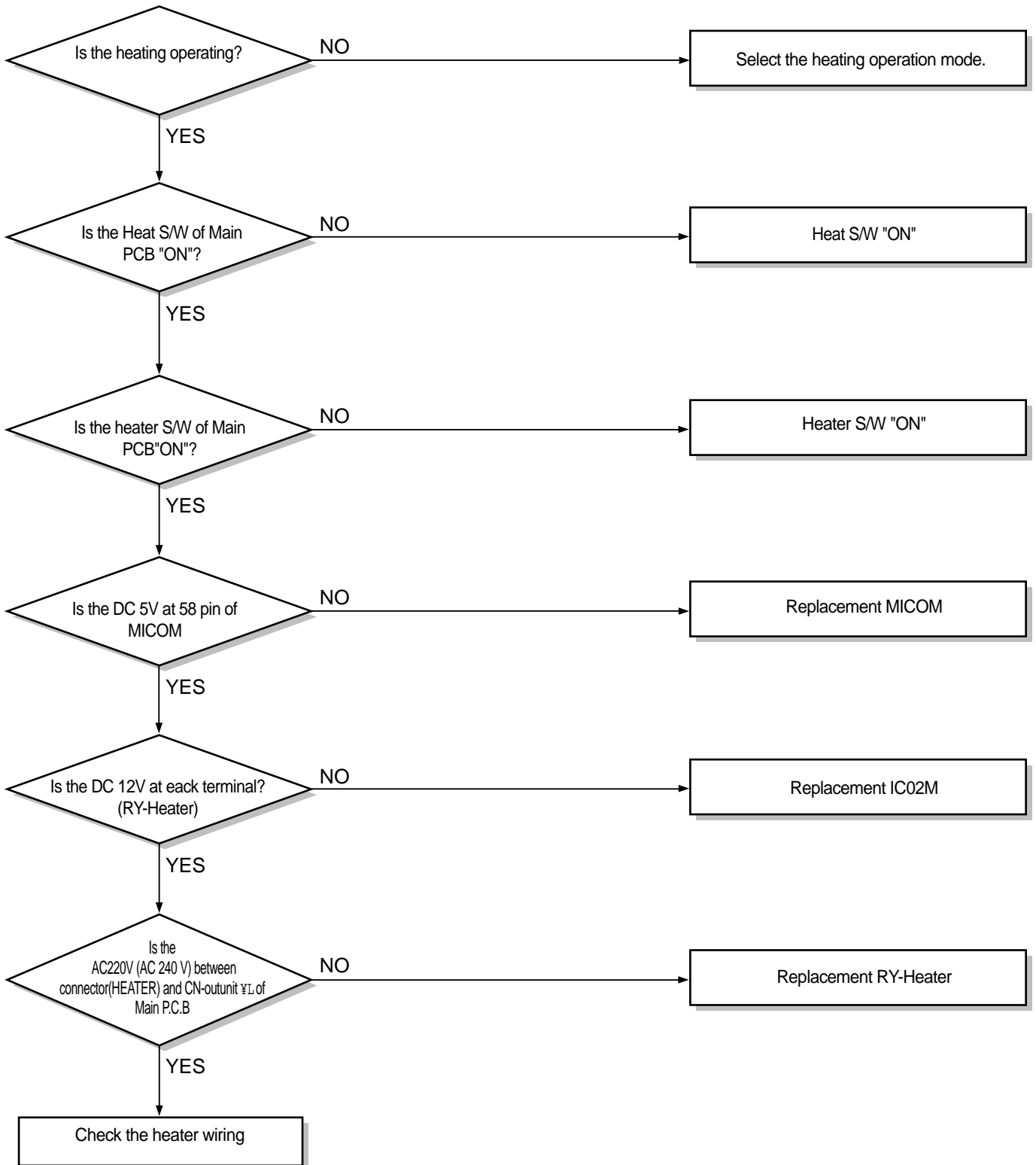



### 9.2 DISPLAY P.C.B ASSY

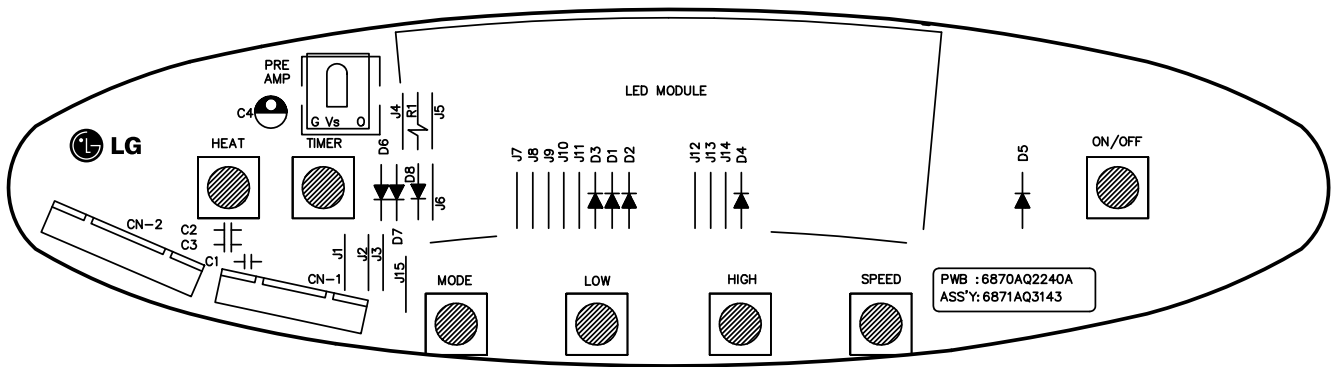

### 9.3 SUB P.C.B ASSY

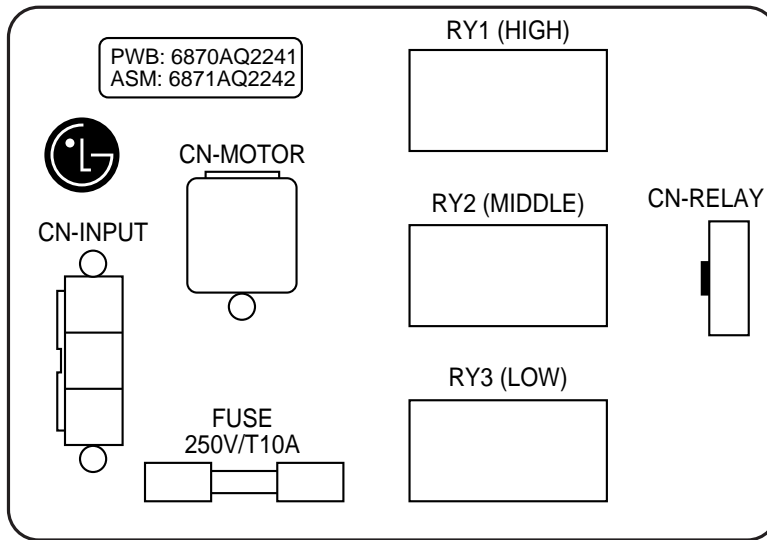

### 9.4 DE-ICER P.C.B ASSY

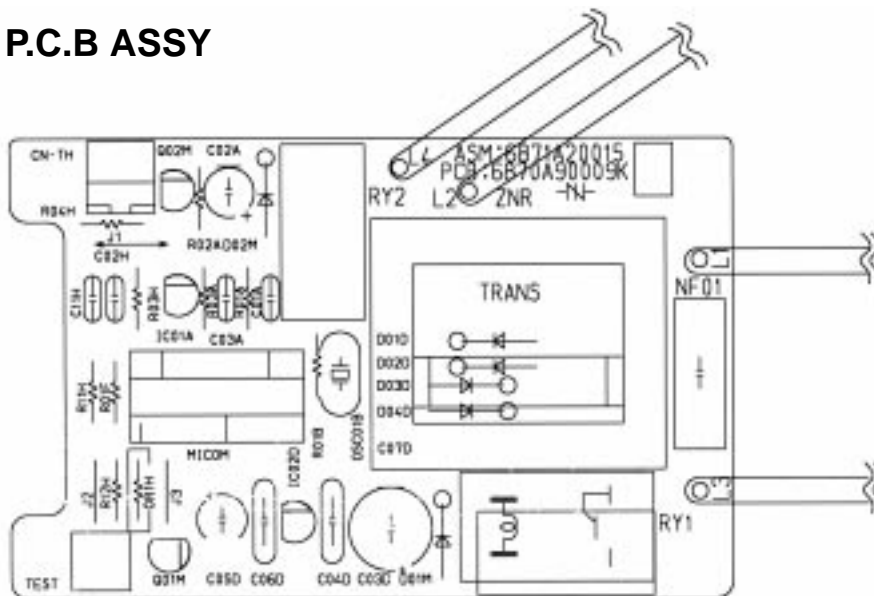

# 10. Schematic Diagram

## Circuit and Troubleshooting

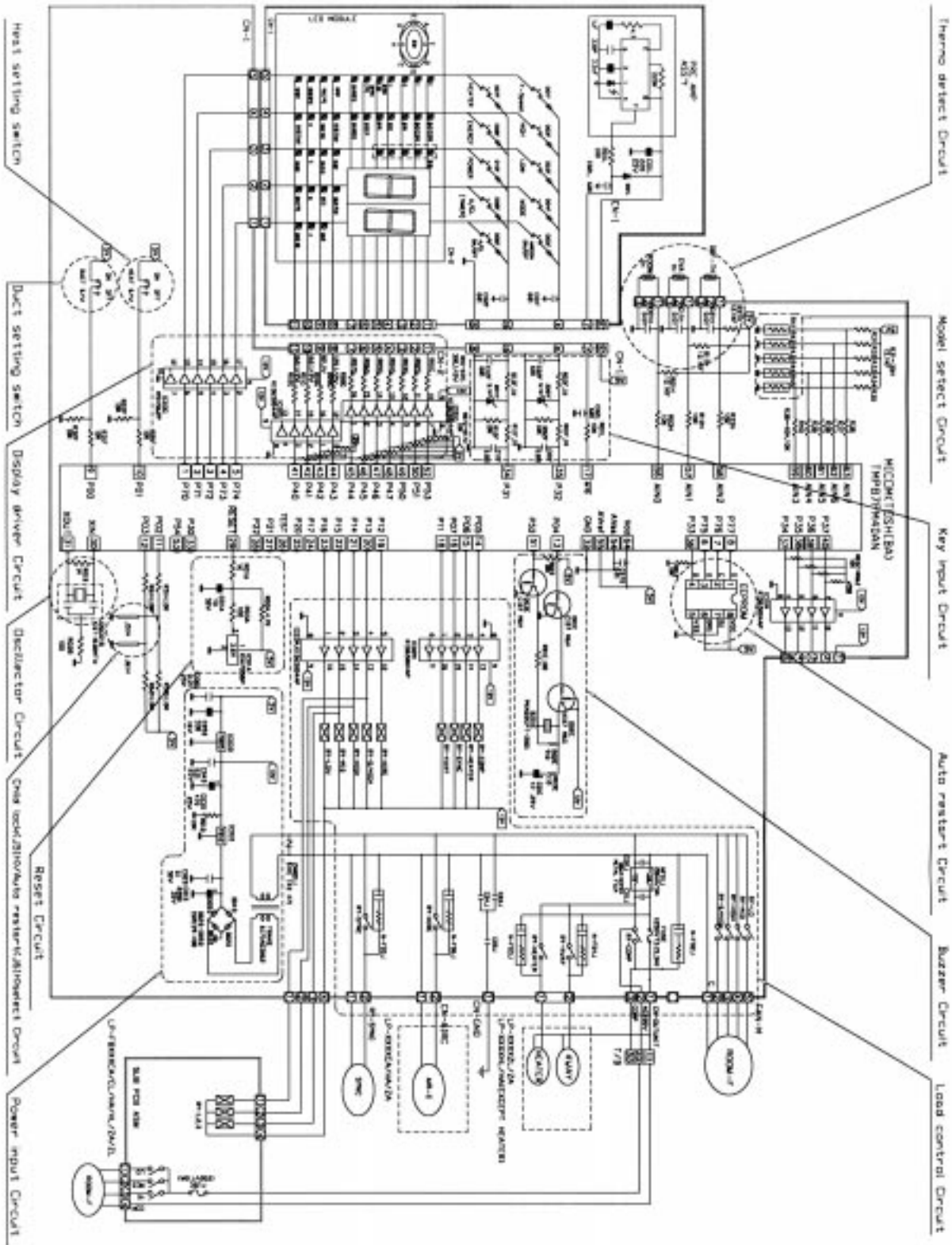

# 11. Exploded View and Replacement Parts List

## Indoor Unit Exploded View

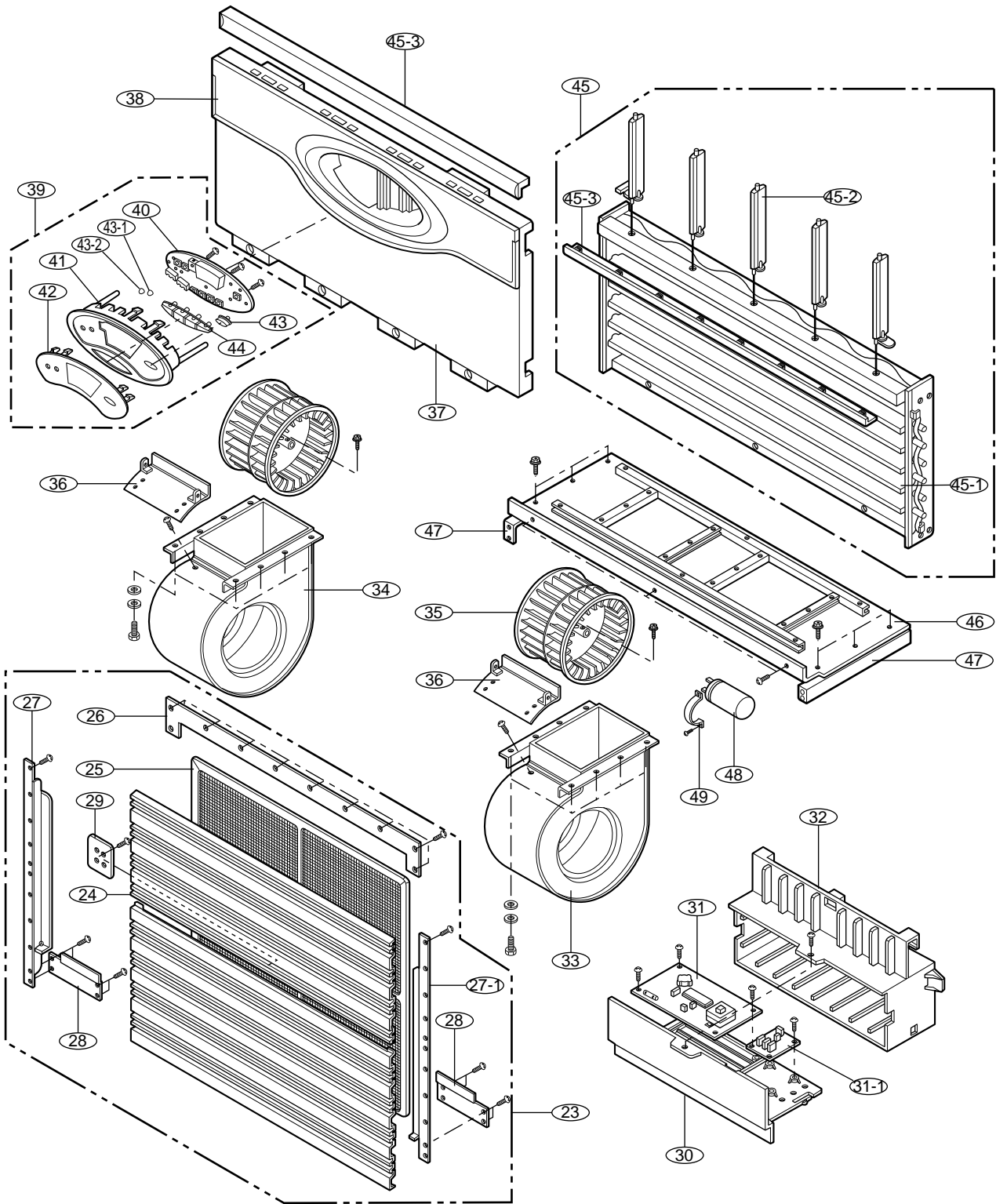

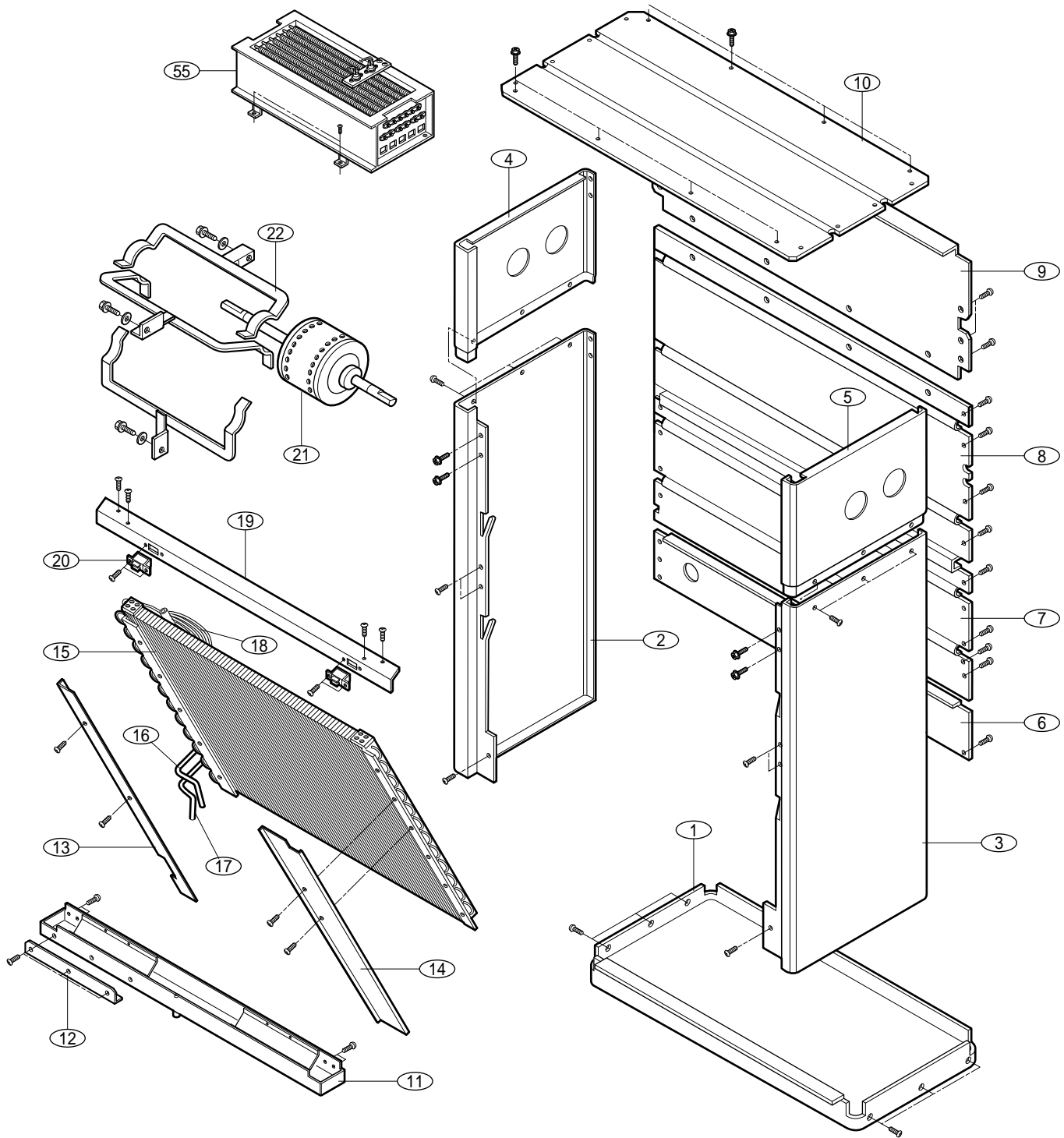



No.	DESCRIPTION	PART No.			Q'TY	REMARK
		LP-F8081CL	LP-F8081HL	LP-F8081ZL		
1	BASE PAN	3040AP2624P	3040AP2624P	3040AP2624P	1	
2	PANEL ASSY SIDE	3721AP3446A	3721AP3446A	3721AP3446A	1	
3	PANEL ASSY SIDE	3721AP3446B	3721AP3446B	3721AP3446C	1	
4	PANEL ASSY SIDE	3721AP3465E	3721AP3465A	3721AP3465C	1	
5	PANEL ASSY SIDE	3721AP3465F	3721AP3465B	3721AP3465D	1	
6	PANEL ASSY REAR-L	3720AP2221A	3720AP2221A	3720AP2221A	1	
7	PANEL ASSY, SIDE	3721AP3466A	3721AP3466A	3721AP3466A	1	
8	PANEL ASSY, SIDE	3721AP3466B	3721AP3466B	3721AP3466B	1	
9	PANEL ASSY, REAR	3721AP3447A	3721AP3447A	3721AP3447C	1	
10	COVER ASSY, TOP(INDOOR)"	3551AP2388A	3551AP2388B	3551AP2388B	1	
11	DRAIN PAN ASS'Y	3087AP2281A	3087AP2281A	3087AP2281A	1	
12	BRACKET	4810AP3333P	4810AP3333P	4810AP3333P	1	
13	BRACKET	4810AP2296B	4810AP2296B	4810AP2296B	1	
14	BRACKET	4810AP2298A	4810AP2298A	4810AP2298A	1	
15	EVAPORATOR ASSY	5420AP2380A	5420AP2380A	5420AP2380A	1	
15-1	EVAPORATOR ASSY, FINAL	5421AP2980A	5421AP2980B	5421AP2980B	1	
16	TUBE ASSY	5211AP2678A	5211AP2678A	5211AP2678A	1	
17	TUBE ASSY	5211AP3959B	5211AP3959B	5211AP3959B	1	
18	TUBE CAPILLARY	5424AP3074G	5424AP3074G	5424AP3074G	15	
19	EVA. BRACKET TOP	5420AP3302A	4811A30016A	4811A30016A	1	
20	DOOR ASSY	3A02221A	3A02221A	3A02221A	1	
21	MOTOR ASSY, AC	4681AP2411G	4681AP2411G	4681AP2411G	1	
22	MOUNT ASSY, MOTOR	3G00788U	3G00788U	3G00788U	1	
23	GRILLE ASSY INLET	5237AP2386A	5237AP2386A	5237AP2386A	1	
24	GRILLE ASSY INLET	3530AP1109A	3530AP1109A	3530AP1109A	2	
25	"FILTER ASSY, A/C"	5231AP3330A	5231AP3330A	5231AP3330A	1	
26	BRACKET	5236AP3294A	5236AP3294A	5236AP3294A	1	
27	GUIDE FILTER	4974AP2225A	4974AP2225A	4974AP2225A	1	
27-1	GUIDE FILTER	4974AP2225B	4974AP2225B	4974AP2225B	1	
28	BRACKET	4810AP3298A	4810AP3298A	4810AP3298A	2	
29	BRACKET	4810AP4051A	4810AP4051A	4810AP4051A	1	
30	BOARD CONTROL(INDOOR)	3500AP2293A	3500AP2293A	3500AP2293A	1	
31	PWB(PCB)ASSY, MAIN	6871A20040U	6871A20040R	6871A20040R	1	
31-1	PWB(PCB) ASSY, SUB	6871AQ2242A	6871AQ2242A	6871AQ2242A	1	
32	CONTROL BOX(INDOOR)	4994AP2291A	4994AP2291A	4994AP2291A	1	
33	HOUSING ASS'Y(MECH)	3661AP1139A	3661AP1139A	3661AP1139A	1	
34	HOUSING ASS'Y(MECH)	3661AP1139B	3661AP1139B	3661AP1139B	1	
35	FAN ASSY, BLOWER	2A00578R	2A00578R	2A00578R	2	
36	CUT OFF	4A00085A	4A00085A	4A00085A	2	
37	PANEL ASSY FRONT	3720AP1136P	3720AP1136P	3720AP1136P	1	
38	HOLDER ASSY DISPLAY	4930AP1133C	4930AP1133C	4930AP1133C	1	
39	DISPLAY ASSY(MECH)	3545A20004D	3545A20004M	3545A20004L	1	
40	PWB(PCB) ASSY, DISPLAY	6871AQ3143Q	6871AQ3143R	6871AQ3143R	1	
41	HOLDER, DISPLAY	3070AP2292K	3070AP2292K	3070AP2292K	1	
42	WINDOW DISPLAY	3790AP3936Q	3790AP3936Q	3790AP7356C	1	

No.	DESCRIPTION	PART No.			Q'TY	REMARK
		LP-F8081CL	LP-F8081HL	LP-F8081ZL		
43	KNOB	4940AP3422C	4940AP3422C	4940AP3422C	1	
43-1	KNOB	4940AP3166E	4940AP3166E	4940AP3166E	1	
43-2	KNOB	4940AP3326E	4940AP3326E	4940AP3326E	1	
44	KNOB	4940A30006A	4940A30006A	4940A30006A	1	
		4940A30006B	4940A30006B	4940A30006B	1	
		4940A30006C	4940A30006C	4940A30006C	1	
		4940A30006D	4940A30006D	4940A30006D	1	
45	GRILLE ASSY, DIFFUSER	3023AP2387B	3023AP2387B	3023AP2387B	1	
45-1	GRILLE	4A01317Z	4A01317Z	4A01317Z	5	
45-2	LOUVER, VERTICAL	3A00752Y	3A00752Y	3A00752Y	12	
45-3	DECORATION	3508AP3328A	3508AP3328C	3508AP3328C	2	
46	BARRIER ASSY	4791AP2300A	4791AP2300B	4791AP2300B	1	
47	BARRIER INDOOR	4790AP3217A/B	4790AP3217A/B	4790AP3217A/B	1	
48	CAPACITOR	2A00986S	2A00986S	2A00986S	1	
49	CLAMP, CAPACITOR	4H00930D	4H00930D	4H00930D	1	
50	ELECTRIC HEATER	-	-	5301A10001A	1	

# Outdoor Unit Exploded View

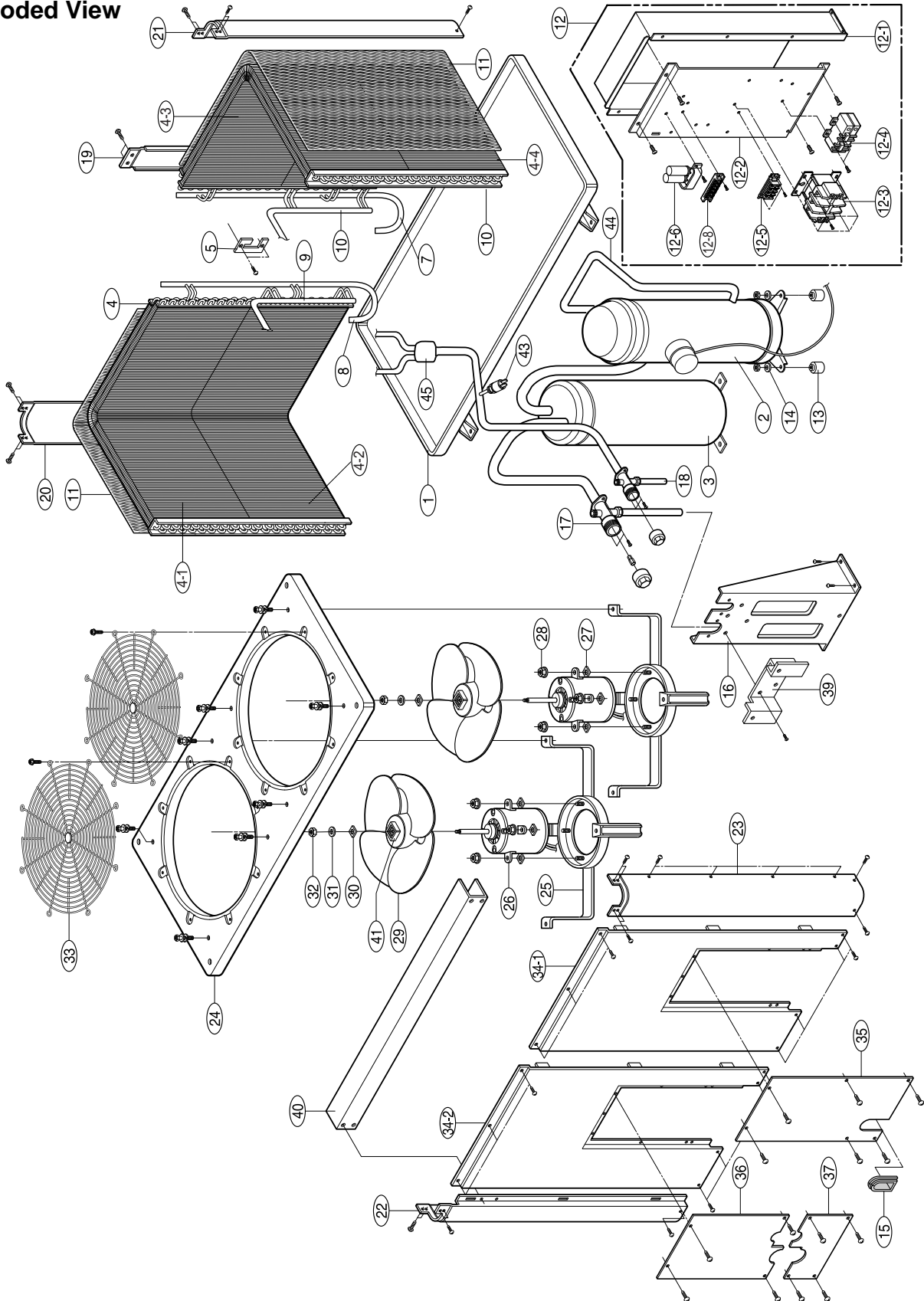

No.	DESCRIPTION	PART No.	Q'TY	REMARK
		LP-F8081CL		
1	BASE ASSY	3041AP2606Q	1	
2	COMPRESSOR	5417AP2982A	1	
4-1	CONDENSER ASSY	5403AP2618H	1	
4-2		5403AP2618H	1	
4-3		5403AP2618H	1	
4-4		5403AP2618H	1	
5	LINK SHEET	4520AP4095A	2	
6	BRACKET COND	4810A30028A	2	
7	TUBE ASSY, (MANIFOLD IN)	5211A30050A	1	
8	TUBE ASSY, (MANIFOLD IN)	5211A30050B	1	
9	TUBE ASSY, (MANIFOLD OUT)	5211AP3868A	1	
10	TUBE ASSY, (MANIFOLD OUT)	5211AP3868B	1	
11	MESH(COVER FIN)	2A00191R	2	
12	CONTROL BOX ASSY	4995AP2854D	1	
12-1	CASE CONTROL	3110AP2592A	1	
12-2	BOARD CONTROL	3500AP2591A	1	
12-3	MAGNATIC CONTACTOR	2A01031C	1	
12-4	PROTECTION RELAY	2A00999C	1	
12-5	TERMINAL BLOCK	3A00493A	1	
12-6	SH-CAPACITOR	2H00841J	2	
12-8	TERMINAL BLOCK	4G00103A	1	
13	REBBER MOUNTING	4022AP9183A	4	
14	BRACKET	4H01811C	4	
15	BUSHING	4830AP4182A	1	
16	SUPPORT VALVE	4980AP2621A	1	
17	VALVE SERVICE	2A00469C	1	
18	VALVE SERVICE	2A00468B	1	
19	COVER TUBING	3550AP2844P	1	
20	SUPPORTER REAR	4980AP1265Q	1	
21	SUPPORTER REAR	4980AP1265P	1	
22	SUPPORTER FRONT	4980AP1264P	1	
23	SUPPORTER FRONT	4980AP1263P	1	
24	ORIFICE ASSY	4948AP1242P	1	
25	MOUNT MOTOR ASSY	3A00434A	2	
26	MOTOR	4680AP2610B	2	
27	BUSHING BASE COMP	4A00077A	11	
28	NUT	4H00947C	12	
29	FAN ASSY	0A00026B	2	
30	FAN LOCKER	4A01387A	2	
31	SPRING LOCK WASHER	1WSD1000030	2	
32	HEXAGON NUTS	1NHA1001206	2	
33	GRILLE COVER	2A00144P	2	
34-1	PANEL ASSY FRONT	3721AP2913P	1	
34-2	PANEL ASSY FRONT	3721AP2913Q	1	
35	COVER ASSY CONTROL	3551AP7047Z	1	
36	PANEL INSTALL-U	3720AP3810P	1	
37	BRACKET INSTALL-L	3720AP3814P	1	
39	BRACKET F.P	4810AP7078A	1	
40	COVER FAN	3550AP3912A	1	
41	HUB FAN	3250AP3964A	2	
43	HIGH PRESSURE SWITCH	6600AG3057A	1	
44	TUBE ASSY,DISCHARGE	5211A30104A	1	
45	TUBE ASSY,CONDENSER	5211A30105A	1	

# Outdoor Unit

## Exploded View

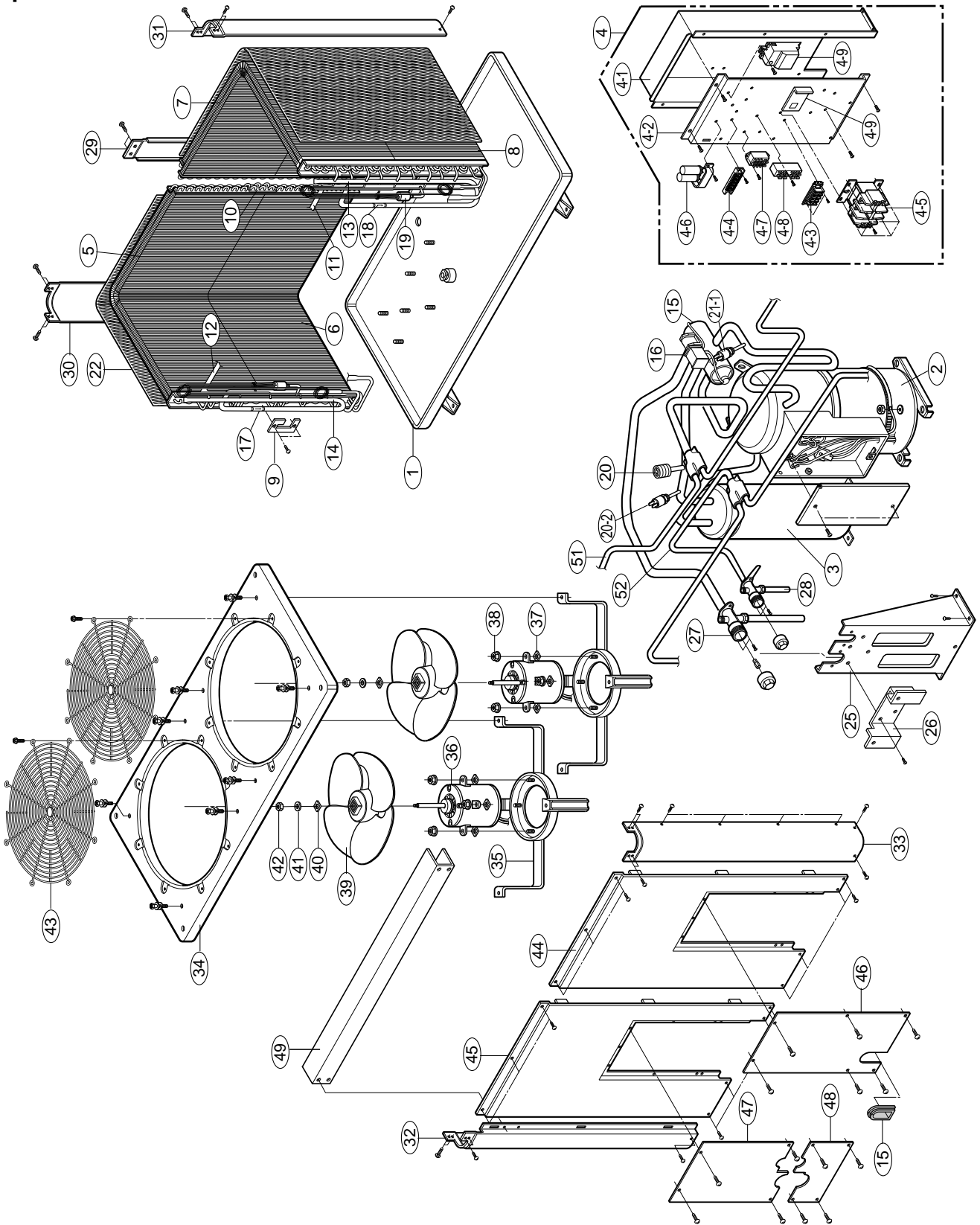

No.	DESCRIPTION	PART No.	Q'TY	REMARK
		LP-F8081HL/ZL		
1	BASE ASSY	3041AP2606V	1	
2	COMPRESSOR	5417AP2982A	1	
3	ACCUMULATOR	3A02139U	1	
4	CONTROL BOX ASSY	4995A20002B	1	
4-1	CASE CONTROL	3110AP2592A	1	
4-2	BOARD CONTROL	3500AP2591A	1	
4-3	TERMINAL BLOCK	3A00493A	1	
4-4	TERMINAL BLOCK	4G00103A	1	
4-5	MAGNATIC CONTACTOR	2A01031C	1	
4-6	SH-CAPACITOR	2H00841J	2	
4-7	RELAY	3A00261C	1	
4-8	TERMINAL BLOCK	3H00390A	1	
4-9	DEICER PCB ASSY	6871A20015T	1	
4-10	3 PHASE DETECTOR	6871A30015D	1	
5	CONDENSER ASSY	5403A20030E	1	
6	CONDENSER ASSY	5403A20030F	1	
7	CONDENSER ASSY	5403A20030G	1	
8	CONDENSER ASSY	5403A20030H	1	
9	LINK SHEET	4520AP4095A	2	
10	BRACKET COND	4810AP3697A	2	
11	TUBE ASSY, (MANIFOLD IN)	5211A30269A	1	
12	TUBE ASSY, (MANIFOLD IN)	5211A30269B	1	
13	TUBE ASSY, (MANIFOLD OUT)	5211A30270C	1	
14	TUBE ASSY, (MANIFOLD OUT)	5211A30270D	1	
15	TUBE ASSY REVER SING	5211A20078B	1	
16	COIL ASYS REVERSING	3A02028B	1	
17	TUBE ASSY CHECK VALVE	5211A30271A	1	
18	TUBE ASSY CHECK VALVE	5211A30271B	1	
19	TUBE ASSY CAPILLIARY	5211A20129B	2	
20	CORE VALVE	3A01902A	1	
21-1	HIGH PRESSURE SWITCH	6600AG3057A	1	
21-2	HIGH PRESSURE SWITCH	3A01100A	1	
22	MESH	2A00191Q	1	
25	SUPPORT VALVE	4980AP2621A	1	
26	BRACKET FRONT	4810AP7078A	1	
27	VALVE SERVICE	2A00469H	1	
28	VALVE SERVICE	2A00468E	1	
29	COVER TUBING	3550A20003P	1	
30	SUPPORTER REAR	4980AP1265Q	1	
31	SUPPORTER REAR	4980AP1265P	1	
32	SUPPORTER FRONT	4980AP1264P	1	
33	SUPPORTER FRONT	4980AP1263P	1	
34	ORIFICE ASSY	4948AP1242P	1	
35	MOUNT MOTOR ASSY	3A00434A	2	
36	MOTOR	4680AP2610B	2	
37	BUSHING BASE COMP	4A00077A	8	
38	NUT	4H00947C	8	
39	FAN ASSY	0A00026B	2	

No.	DESCRIPTION	PART No.	Q'TY	REMARK
		LP-F8081HL/ZL		
40	FAN LOCKER	4A01387A	2	
41	SPRING LOCK WASHER	1WSD1000030	2	
42	HEXAGON NUTS	1NHA1001206	2	
43	GRILLE COVER	2A00144P	2	
44	PANEL ASSY FRONT	3721AP2913P	1	
45	PANEL ASSY FRONT	3721AP2913Q	1	
46	COVER ASSY CONTROL	3551AP7047Z	1	
47	PANEL INSTALL-U	3720AP3810P	1	
48	BRACKET INSTALL-L	3720AP3814P	1	
49	COVER FAN	3550AP3912A	1	
51	TUBE ASSY,CONDENSER	5211A30219A	1	
52	TUBE ASSY,CONNECTOR	5211A30272A	1	

