

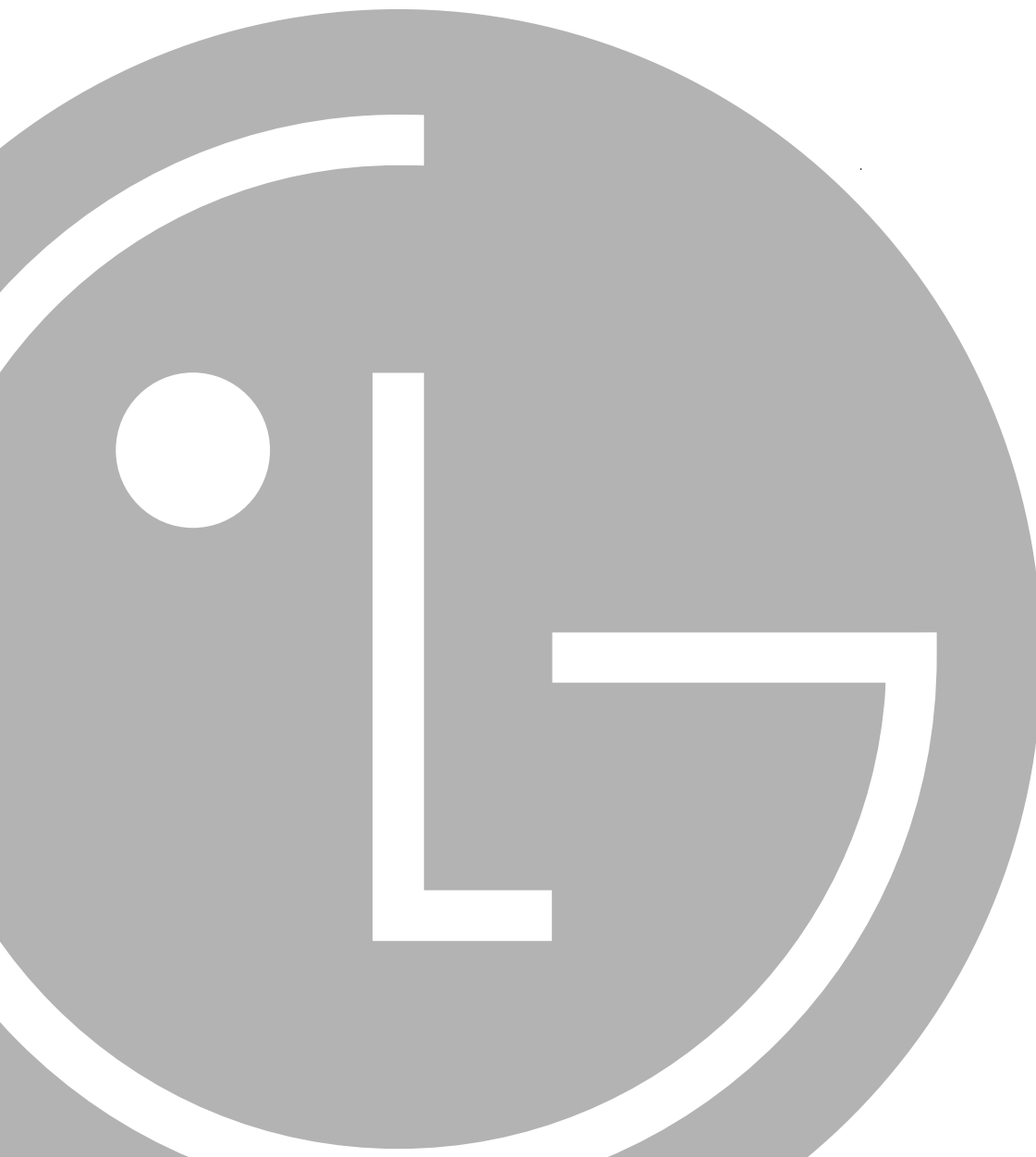

Multi Type Room Air Conditioner

SERVICE MANUAL

**MODEL: LM-2421C2L
LM-3022C3L**



Contents

Functions	3
Product Specifications	4
Dimensions	6
Refrigeration Cycle Diagram	9
Wiring Diagram	11
Operation Details	12
Display Function/Self-diagnosis Function	14
Installation	15
Operation	31
Disassembly of the parts (Indoor Unit)	32
2-way, 3-way Valve	34
Cycle Troubleshooting Guide	38
Electronic Parts Troubleshooting Guide	40
Electronic Control Device	46
Schematic Diagram	47
Exploded View and Replacement Parts List	50

Functions

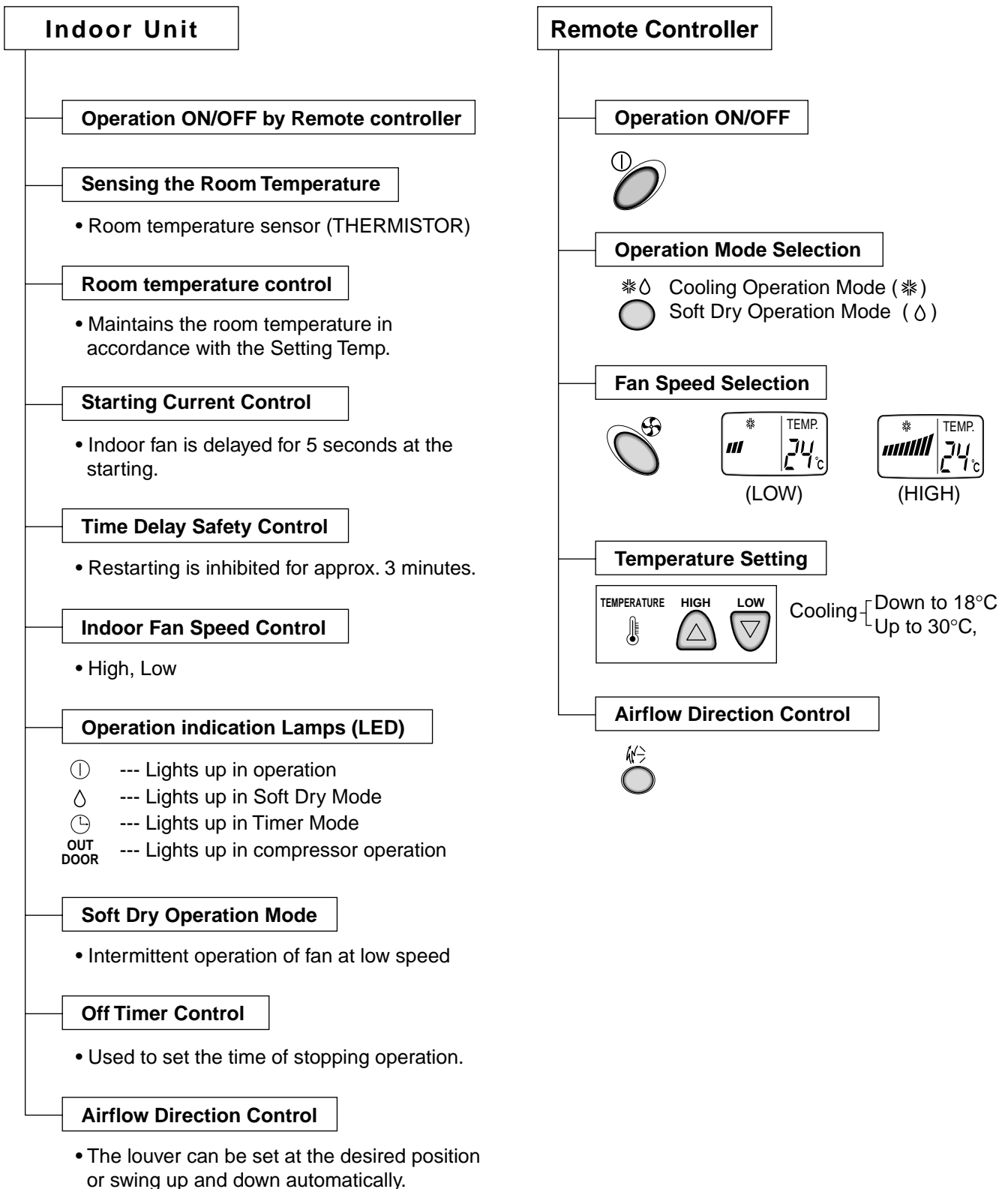

Product Specifications(Cooling Only)

1. LM-2421C2L

Item	Operation		A or B unit		A + B unit	
	Unit					
Cooling Capacity	Btu/h(kcal/h)		17,000(4,270)		24,000(6,050)	
Moisture Removal	/h		1.6		1.6 x 2	
Power Source	ø, V, Hz		1Ø, 220, 60HZ			
Air Circulation	m ³ /min	Indoor	9.0			
		Outdoor	49			
Noise Level(Low)	dB(A)	Indoor	38+1			
		Outdoor	56+1			
Input	W		2,260		2,410	
Runnig Current	A		10.5		11.5	
E.E.R.	Btu/h·w		7.5		9.96	
Motor Output	W	Indoor	14.4			
		Outdoor	90			
Dimensions(W x H x D)	mm	Indoor	888 x 287 x 170			
		Outdoor	870 x 655 x 320			
Net. Weight	kg	Indoor	9			
		Outdoor	61			
Refrigerant(R-22)	g		1,650(7.5m Base)			
Airflow Direction Control(Up & Down)			O			
Remocon Type			L.C.D Wireless			
Service Valve		Liquid	1/4"(6.35)			
		Gas	1/2"(12.7)			
Drain Hose			O			

2. LM-3022C3L

Item	Unit	Operation					
		A-Unit	B or C-Unit	A+B or C	B+C	A+B+C	
Cooling Capacity	Btu/h(kcal/h)	14,000(4,000)	14,000(4,000)	22,000(6,000)	22,000(5,800)	20,000(7,300)	
Moisture Removal	/h	1.4	1.6	3	3.2	4.6	
Power Source	ø, V, Hz	1Ø, 220V, 60Hz					
Air Circulation	m ³ /min	Indoor	9.5	9.5	8.8 + 7.8	7.8 + 7.8	8.8 + 7.8 + 7.8
		Outdoor	53	-	-	-	-
Noise Level(Low)	dB(A)	Indoor	38	40	-	-	-
		Outdoor	60				
Input	W	2,250	2,250	2,500	2,500	2,600	
Runnig Current	A	10.5	10.5	11.5	11.5	12	
E.E.R.	Btu/h·w	6.22	6.22	8.8	8.8	10.77	
Motor Output	W	Indoor	13.6/15				
		Outdoor	90				
Dimensions(W x H x D)	mm	Indoor	888 x 287 x 170				
		Outdoor	870 x 655 x 320				
Net. Weight	kg	Indoor	10	-	-	-	
		Outdoor	63				
Refrigerant(R-22)	g	1,800					
Airflow Direction Control(Up & Down)		O					
Remocon Type		L.C.D Wireless					
Service Valve	Liquid	1/4"(6.35)	-	-	-		
	Gas	1/2"(12.7)	-	-	-		
Drain Hose		O					

Dimensions

1. Indoor Unit

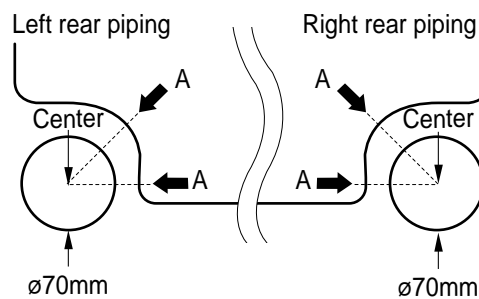
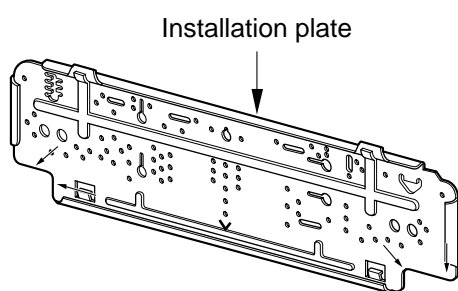
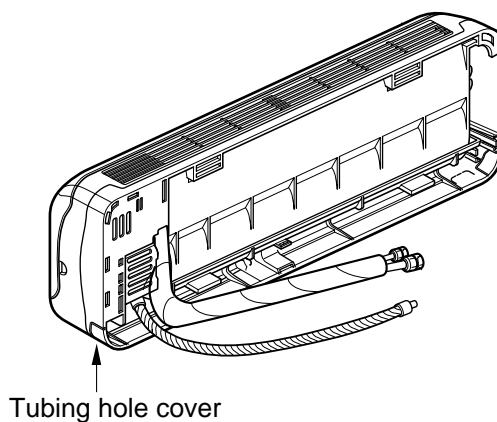
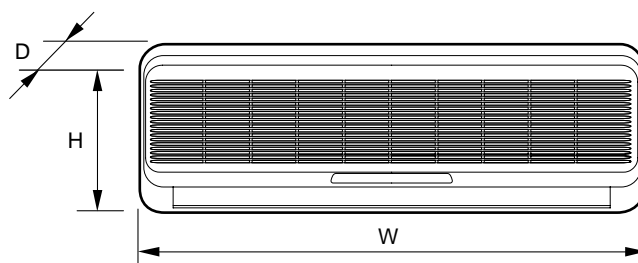

MODEL		LM-2421C2L, LM-3022C3L
DIM		
W	mm	888
H	mm	287
D	mm	170

2. Outdoor Unit

2-1. LM-2421C2L

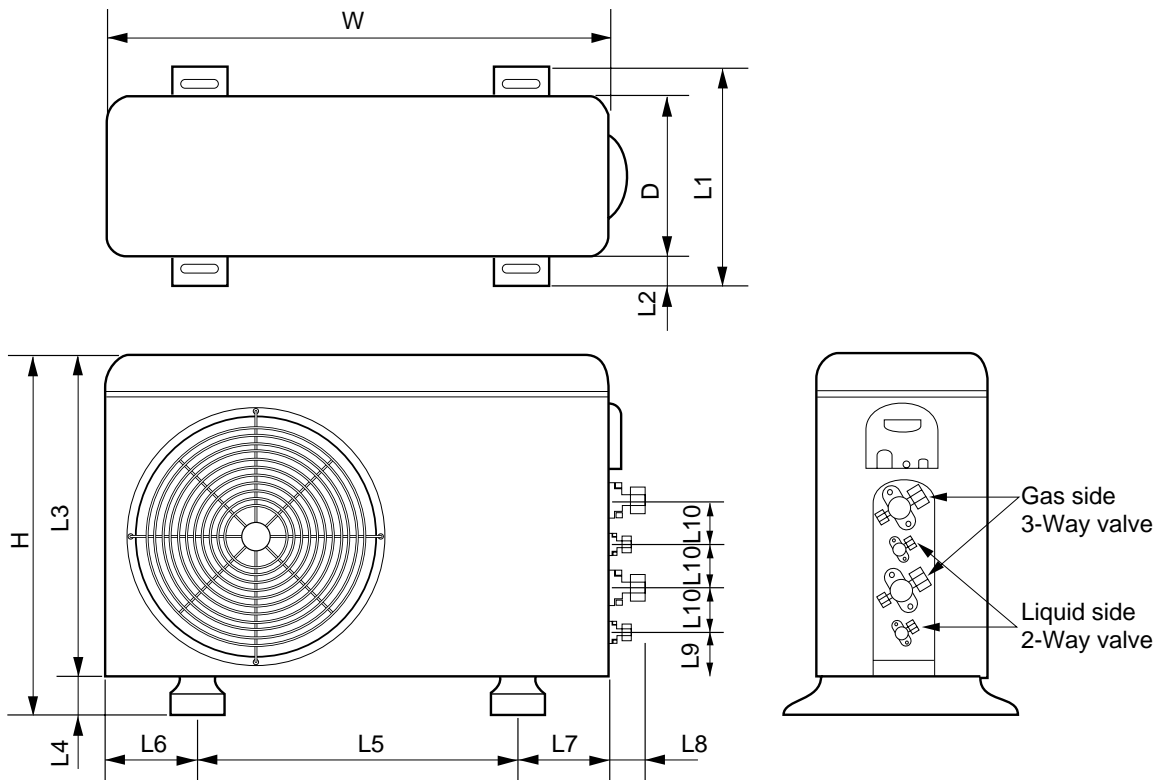

MODEL		LM-2420C2L
DIM		
W	mm	870
H	mm	655
D	mm	320
L1	mm	370
L2	mm	25
L3	mm	630
L4	mm	25
L5	mm	546
L6	mm	160
L7	mm	160
L8	mm	64
L9	mm	76.5
L10	mm	50

2-2. LM-3022C3L

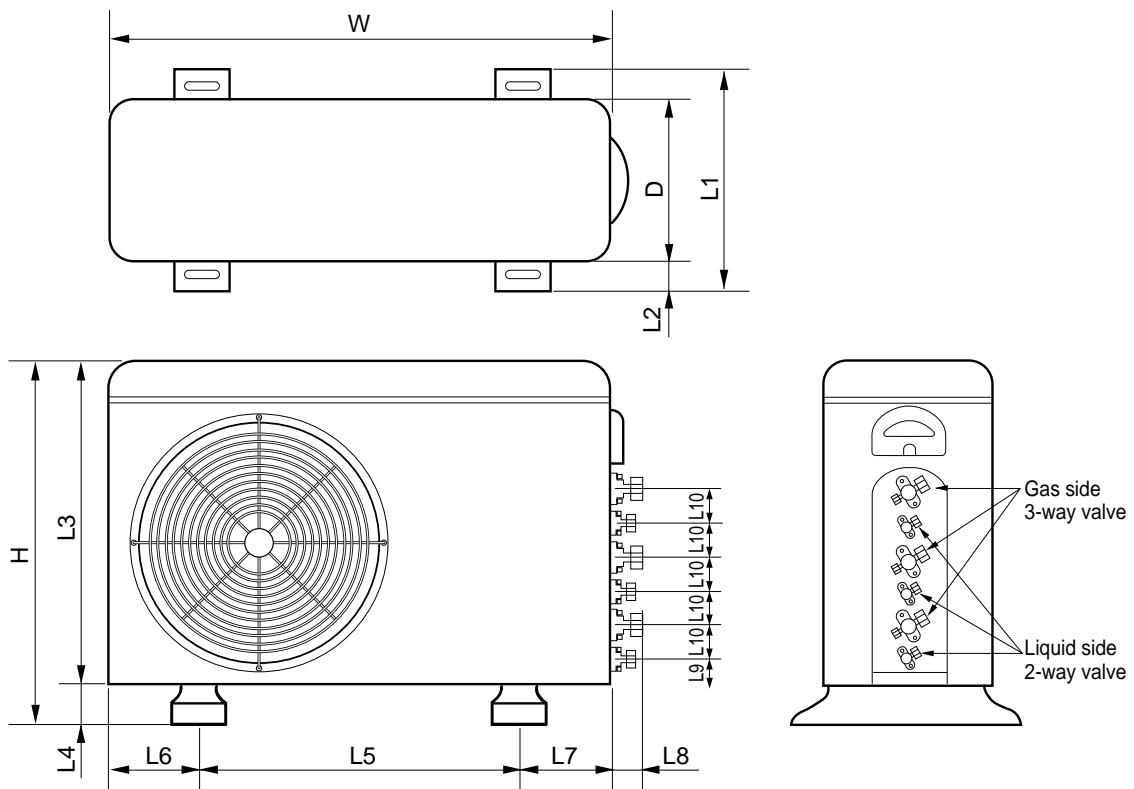

MODEL		LM-3022C3L
DIM		
W	mm	870
H	mm	655
D	mm	320
L1	mm	370
L2	mm	25
L3	mm	630
L4	mm	25
L5	mm	546
L6	mm	160
L7	mm	160
L8	mm	64
L9	mm	76.5
L10	mm	50

Refrigeration Cycle Diagram

1. LM-2421C2L

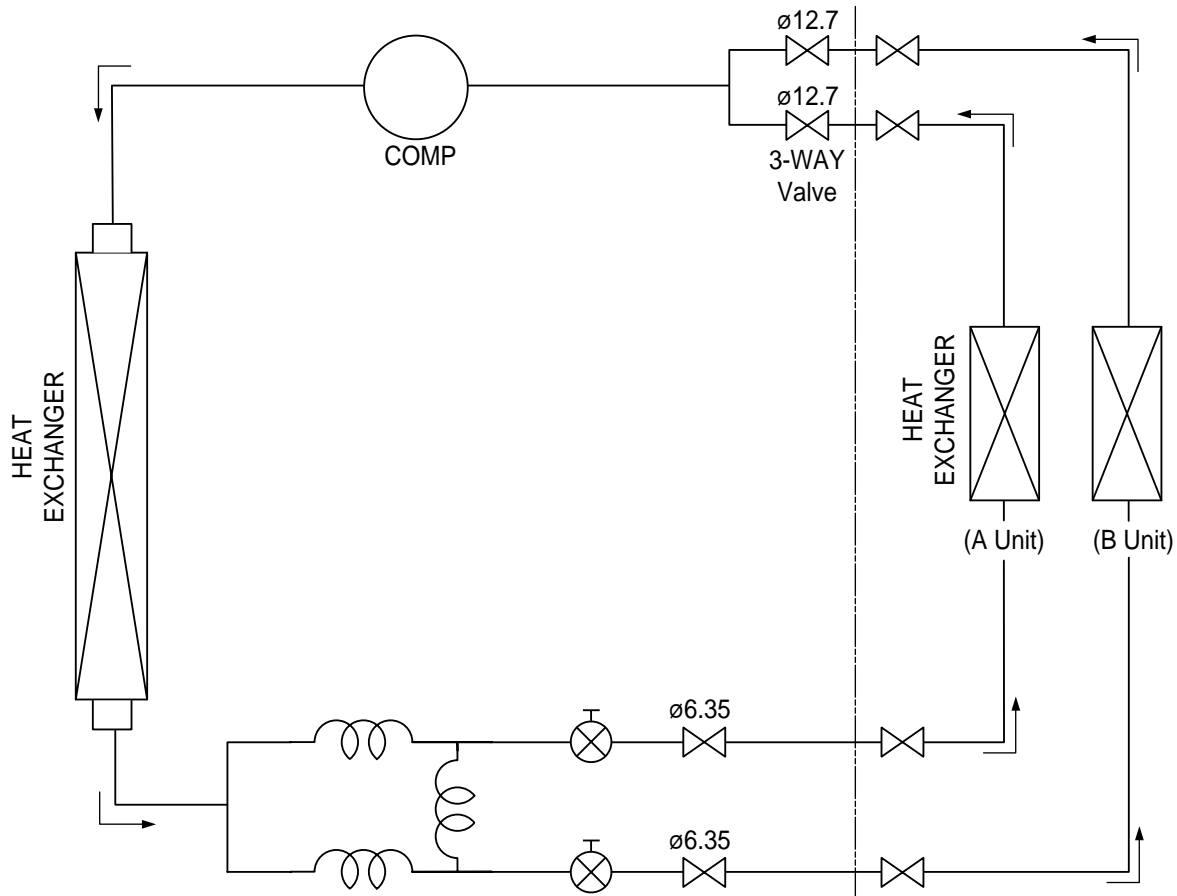

Pipe Size (Diameter : inch)		Max. piping length (m)	Max. piping elevation (m)
Gas	Liquid		
1/2"	1/4"	10~15	5~7

ex)	Symbol	Description
		Solenoid Valve
		Capillary
		Cooling

2. LM-3022C3CL

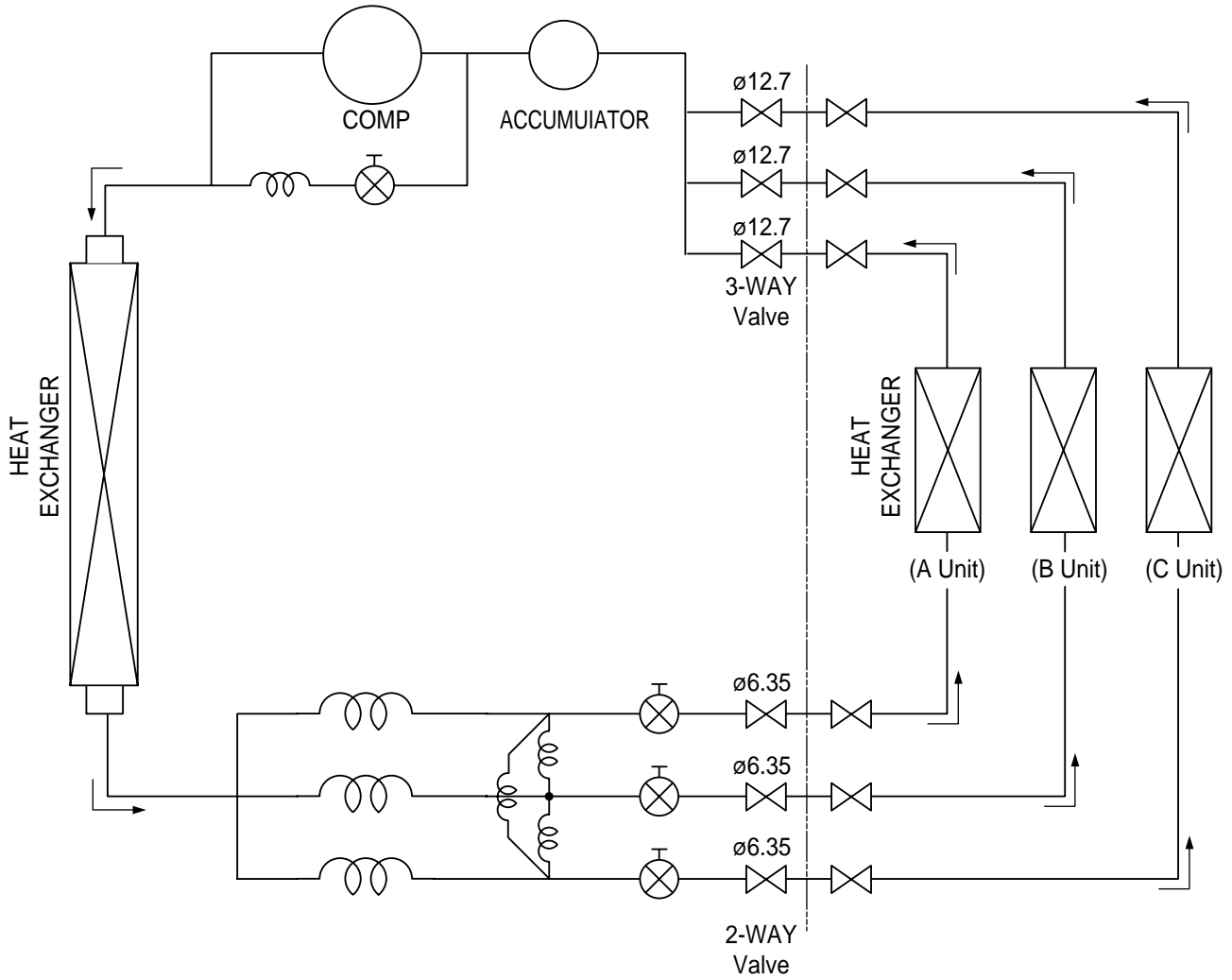

Pipe Size (Diameter : inch)		Max. piping length (m)	Max. piping elevation (m)
Gas	Liquid		
1/2"	1/4"	10~15	5~7

ex)

	Solenoid Valve
	Capillary
	Cooling

Wiring Diagram(Cooling Only)

1-1. Indoor Unit (LM-2421C2L, LM-3022C3L)

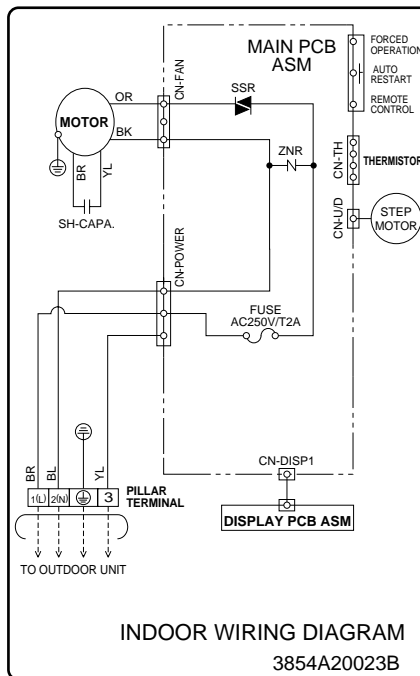

1-2. Outdoor Unit

• LM-2421C2L

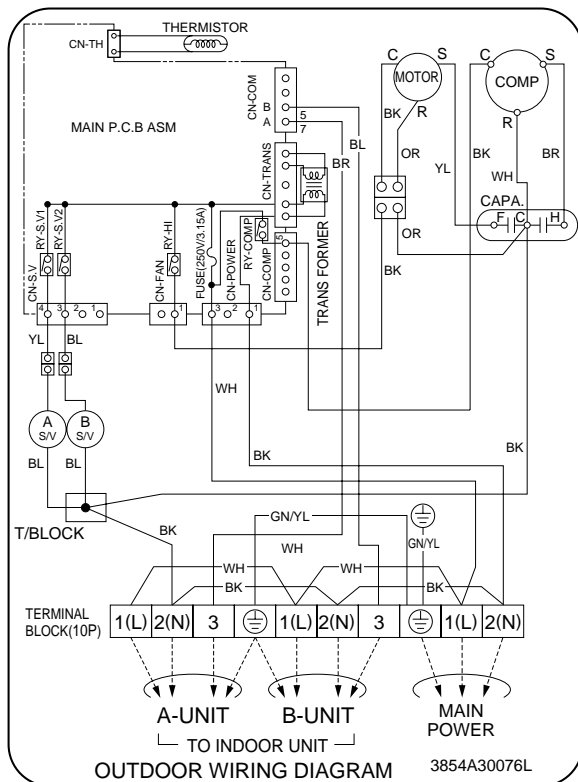

• LM-3022C3L

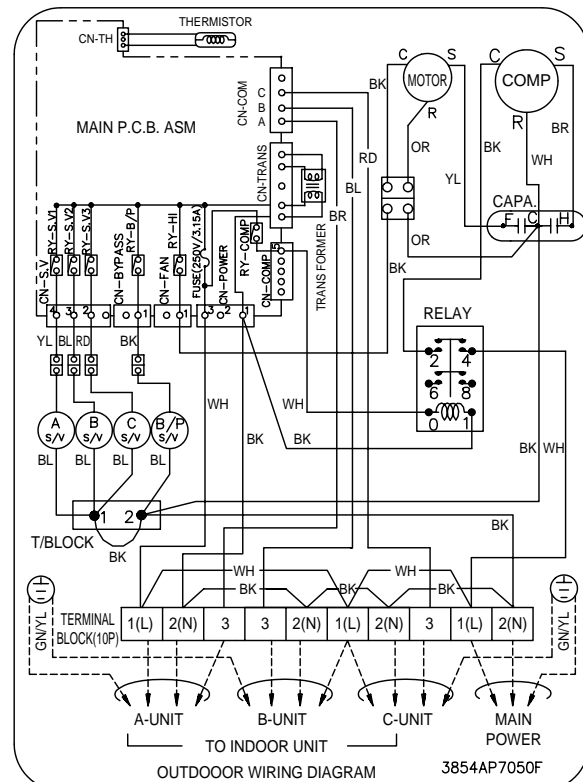

Operation Details

1. MAIN UNIT FUNCTION

• DISPLAY

Operation Indicator

- On while in appliance operation, off while in appliance pause
- Flashing while in disconnection or short in Thermistor (3 sec off / 0.5 sec on)

Soft Dry Indicator

- On while in healthy dehumidification mode, off when healthy dehumidification is cancelled.

Timer Indicator

- On while in timer mode (on/off), off when timer mode is completed or canceled.

Comp. Running Indicator

- While in appliance operation, on while in outdoor unit compressor running, off while in compressor off

■ Cooling Mode Operation

- When the intake air temperature reaches 0.5°C below the setting temp, the compressor and the outdoor fan stop.
- When it reaches 0.5°C above the setting temp, they start to operate again.
 - Compressor ON Temp ▶ Setting Temp+0.5°C
 - Compressor OFF Temp ▶ Setting Temp-0.5°C
- While in compressor running, operating with the airflow speed set by the remote control. While in compressor not running, operating with the low airflow speed regardless of the setting.

■ Healthy Dehumidification Mode

- When the dehumidification operation input by the remote control is received, the intake air temperature is detected and the setting temp is automatically set according to the intake air temperature.
 - 26°C ≤ Intake Air Temp ▶ 25°C
 - 24°C ≤ Intake Air Temp < 26°C ▶ Intake Air Temp-1°C
 - 18°C ≤ Intake Air Temp < 24°C ▶ Intake Air Temp-0.5°C
 - Intake Air Temp < 18°C ▶ 18°C
- While in compressor off, the indoor fan repeats low airflow speed and pause.
- While the intake air temp is between compressor on temp. and compressor off temp., 10-min dehumidification operation and 4-min compressor off repeat.
 - Compressor ON Temp. ▶ Setting Temp+0.5°C
 - Compressor OFF Temp. ▶ Setting Temp-0.5°C
- In 10-min dehumidification operation, the indoor fan operates with the low airflow speed.

■ Cooling overload

- Outdoor fan ON/OFF by sensing outdoor pipe temperature.
- Outdoor fan is OFF if pipe temperature is below 0°C and outdoor fan is ON if pipe temperature is over 0°C.

■ Airflow Speed Selection

- The airflow speed of the indoor fan is set to high, low by the input of the airflow speed selection key on the remote control.

■ Off-Timer Operation

- When the set time is reached after the time is input by the remote control, the appliance stops operating.
- The timer LED is on when the off-timer is input. It is off when the time set by the timer is reached.
- If the appliance is on pause at the time set by the timer, the pause continues.

■ Auto Restarting Operation

- When the power is restored after a sudden power failure while in appliance operation, the mode before the power failure is kept on the memory and the appliance automatically operates in the mode on the memory.
- The slide switch on the main unit of the appliance should be on the Auto Restarting position in order that the Auto Restarting operation is available.
- Operation Mode that is kept on the memory
 - State of Operation ON/OFF
 - Operation Mode/Setting Temp/Selected Airflow Speed

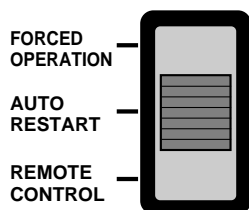

Slide Switch

■ Forced Operation (C/O Model)

- To operate the appliance by force in case that the remote control is lost, the forced operation selection switch is on the main unit of the appliance to operate the appliance in the standard conditions.
- When the power is supplied while the slide switch is on the forced operation position, or when the slide switch position is switched to the Auto Restarting position (or test operation) or switched from the remote control position to the forced operation position while the power is on, the forced operation is carried out.
- When the slide switch position is switched from the forced operation position to the Auto Restarting position or the remote control position, the forced operation is canceled and the appliance stops operating.
- The forced operation is carried out in cooling mode with the setting temperature 22°C and the high speed of airflow.
- While in forced operation, the key input by the remote control has no effect and the buzzer sounds 10 times to indicate the forced operation.

■ Remote Control Operation Mode

- When the remote control is selected by the slide switch on the main unit, the appliance operates according to the input by the remote control.

■ Protection of the evaporator pipe from frosting

- If the indoor pipe temp is below 0°C in 7 min. after the compressor operates without any pause while in cooling cycle operation mode, the compressor and the outdoor fan are turned off in order to protect the indoor evaporator pipe from frosting.
- When the indoor pipe temp is 7°C or higher after 3 min. pause of the compressor, the compressor and the outdoor fan is turned on according to the condition of the room temperature.

■ Buzzer Sounding Operation

- When the appliance-operation key is input by the remote control, the short "beep-beep-" sounds.
- When the appliance-pause key is input by the remote control, the long "beep—" sounds.
- When a key is input by the remote control while the slide switch on the main unit of the appliance is on the forced operation position, the error sound "beep-beep-beep-beep-beep-" is made 10 times to indicate that the remote control signal cannot be received.

Display Function

Cooling Model

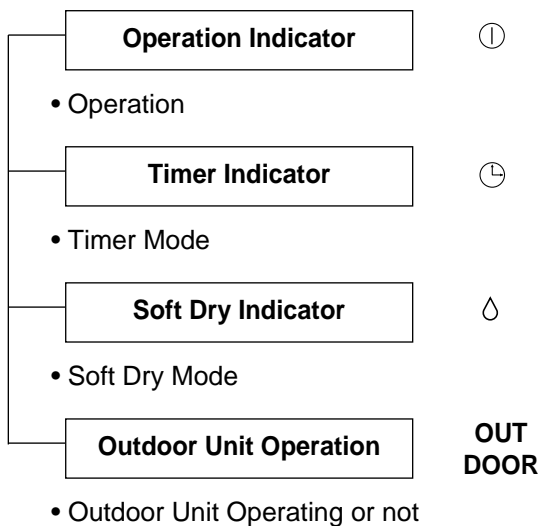

Self-diagnosis Function

■ Error Indicator

- The function is to self-diagnosis airconditioner and express the troubles identifiably if there is any trouble.
- Error mark is ON/OFF for the operation LED of evaporator body in the same manner as the following table.
- If more than two troubles occur simultaneously, primarily the highest trouble fo error code is expressed.
- After error occurrence, if error is released, error LED is also released simultaneously.
- To operate again on the occurrence of error code 12, be sure to pull out power cord and then re-insert.

Error Code	Error LED (Indoor body operation LED)	Error contents	SVC check point
1	<p>(once)</p> <p>3sec 3sec 3sec</p>	<ul style="list-style-type: none"> • Indoor suction temperature thermistor open/short. • Indoor pipe temperature thermistor open/short. 	<ul style="list-style-type: none"> • Indoor TH ass'y check
2	<p>(twice)</p> <p>3sec 3sec</p>	<ul style="list-style-type: none"> • Outdoor suction temperature thermistor open/short. • Outdoor pipe temperature thermistor open/short. 	<ul style="list-style-type: none"> • Outdoor TH ass'y check
3	<p>(5times)</p> <p>3sec</p>	<ul style="list-style-type: none"> • Poor communication 	<ul style="list-style-type: none"> • Communication line/circuit check

Installation

(1) Installation of Indoor, Outdoor unit

1) Selection of the best location

1. Indoor unit

- There should not be any heat source or steam near the unit.
- There should not be any obstacles to prevent the air circulation.
- A place where air circulation in the room will be good.
- A place where drainage can be easily obtained.
- A place where noise prevention is taken into consideration.
- Do not install the unit near the door way.
- Ensure the spaces indicated by arrows from the wall, ceiling, fence, or other obstacles.

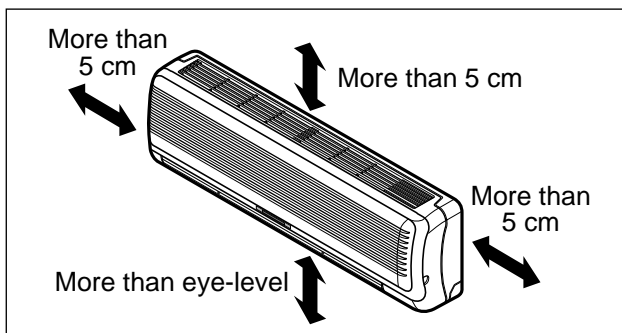
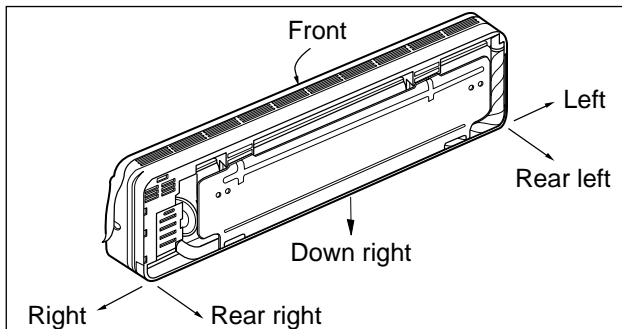

2. Outdoor unit

- If an awning is built over the unit to prevent direct sunlight or rain exposure, be careful that heat radiation from the condenser is not restricted.
- There should not be any animals or plants which could be affected by hot air discharged.
- Ensure the spaces indicated by arrows from the wall, ceiling, fence, or other obstacles.

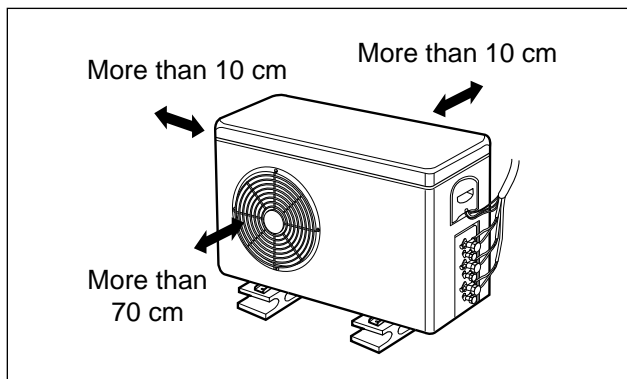

3. Piping length and the elevation

Pipe Size		Max. piping length A (m)	Max. Elevation B (m)
GAS	LIQUID		
1/2"	1/4"	10~15	5~7

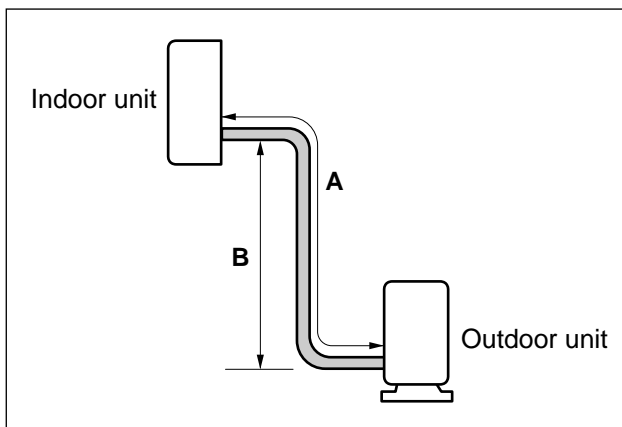

2) Indoor Unit Installation

The mounting wall should be strong and solid enough to protect it from the vibration.

1. Mount the installation plate on the wall with four Type "A" screws.

(If mounting the unit on the concrete wall, consider using anchor bolts.)

- Always mount the Installation plate horizontally by aligning the marking-off line by means of the thread and a level.

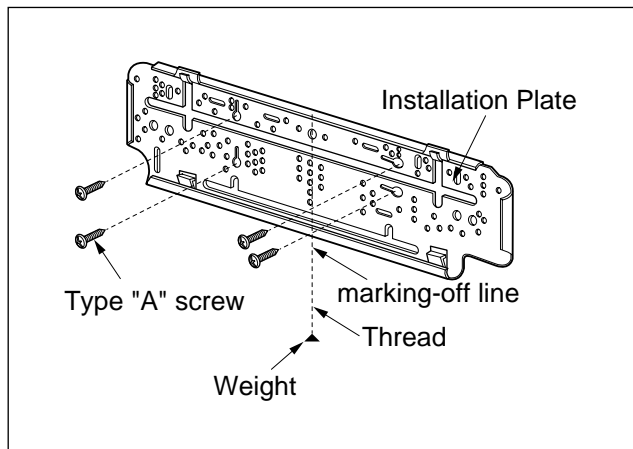

2. Drill the piping hole with 70mm dia. holecore drill.

- Line according to the arrows marked on lower the left and the right side of the Installation Plate. The meeting point of the extended line is the center of the hole.
- Drill the piping hole at either the right or the left and the hole should be slightly slant to the outdoor side.

The lower left and the right side of Installation Plate

9K, 10K, 12K BTU

Left rear piping Right rear piping

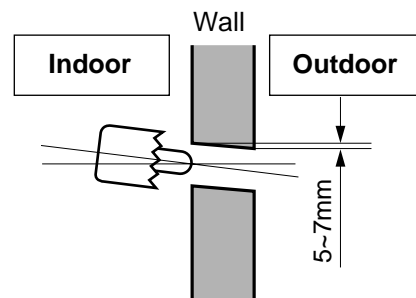
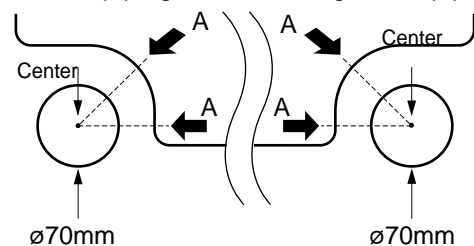

CAUTION

1. After installation, remove a piece of insulation at the slide switch.
2. After installation or service, confirm that the slide switch is at "REMOTE CONTROL"

(2) Piping and Drainage of Indoor Unit

1) Preparation of pipings

1. Cut the pipes and the cable.

- Use the accessory piping kit or the pipes purchased locally.
- Measure the distance between the indoor and the outdoor unit.
- Cut the pipes a little longer than the measured distance.
- Cut the cable 1.5m longer than the length of the pipe.

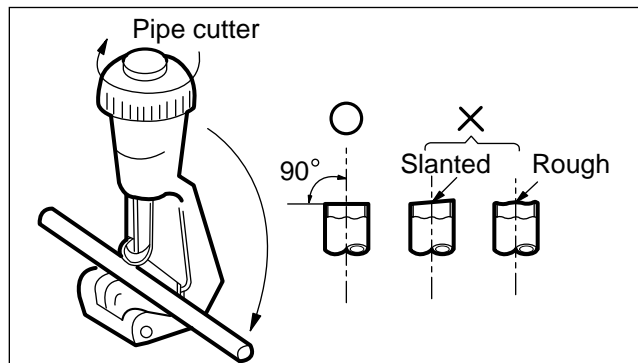

2. Remove burrs.

- Remove burrs from cut edges of pipes.
- Turn the pipe end toward down to avoid the metal powder entering the pipe.

Caution:

If burrs are not removed, they may cause a gas leakage.

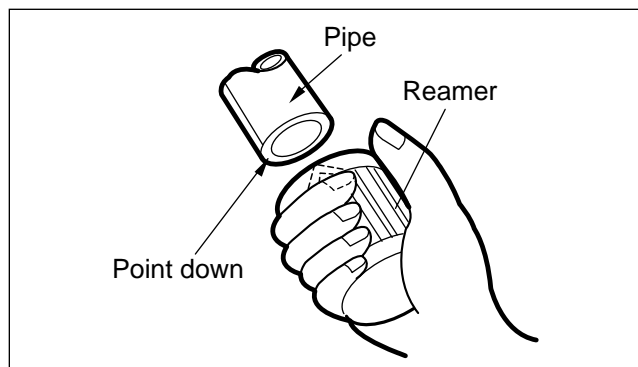

3. Flaring the pipes.

- Insert the flare nuts, mounted on the connection ports of both indoor and outdoor unit, onto the copper pipes. Some refrigerant gas may leak, when the flare nuts are removed from the indoor unit, as some gas is charged to prevent the inside of the pipe from rusting.
- Fit the copper pipe end into the Bar of flare tool about 0~0.5mm higher. (See illustration)
- Flare the pipe ends.

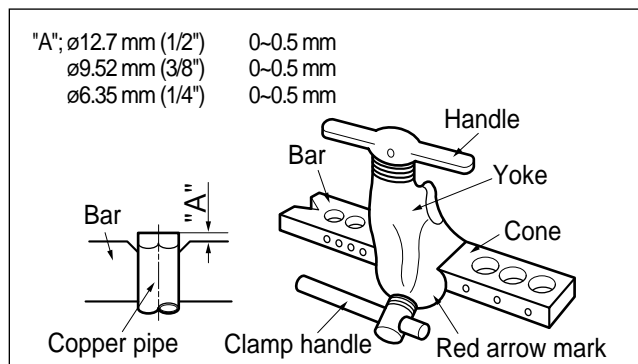

4. Tape the flaring portion to protect it from the dust or damages.

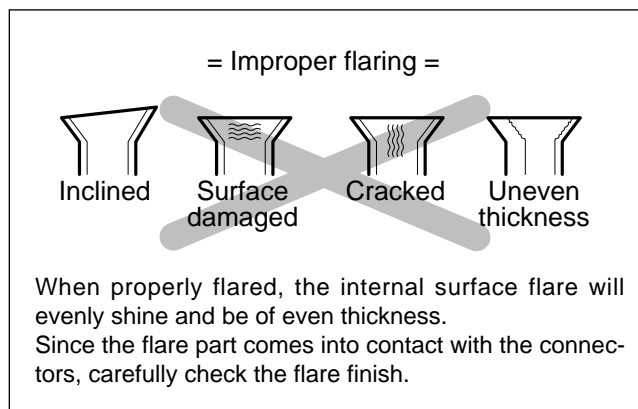

2) Connection of Pipings

1. Remove the installation plate

- Pull the two 'Δ' marked portion of bottom of the chassis and pull the installation plate out of chassis.

2. Route the drain hose and the indoor tubing.

For right rear piping

3. Insert the pipings, the connecting cables and the drain pipe through the piping hole on the wall.

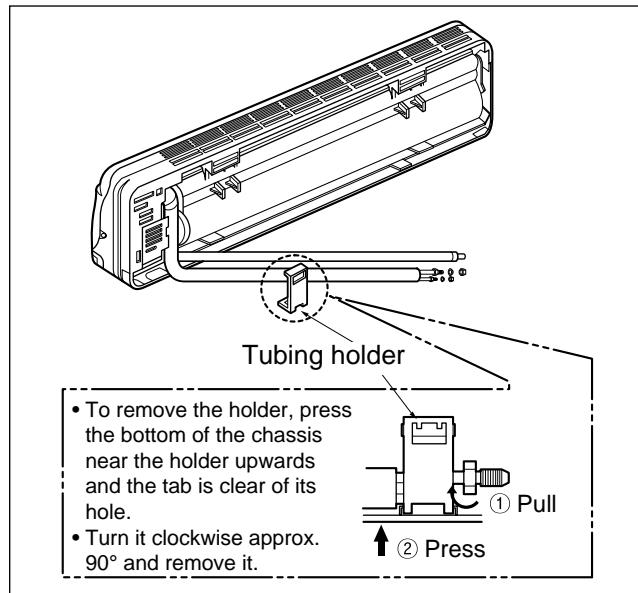
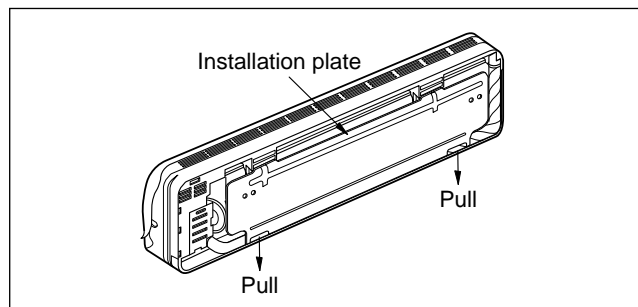

4. Connect the pipings and the indoor tubing, and drain hose and drain pipe.

- Don't connect the cable to the indoor unit.

Pipe Size	Torque
Liquid Side (1/4")	1.8kg-m
Gas Side (1/2")	5.5kg-m

- Wrap the insulation material around the connecting portion.
- Glue up the connection portion of drain hose and drain pipe.

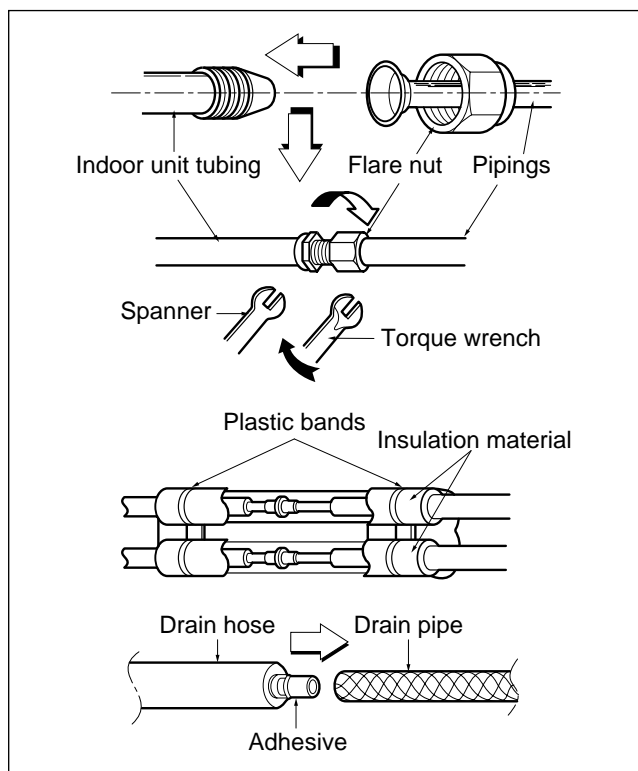

5. Bend the tubing as shown in the figure and bind the pipings, the connecting cables and the drain hose altogether.

- Make a small loop for easy connection later.

6. Tape the tubing, drain hose and the connecting cable. Be sure that drain hose locates at the lowest side of the bundle.

Locating at the upper side can be a reason that drain water overflows drain pan inside the unit.

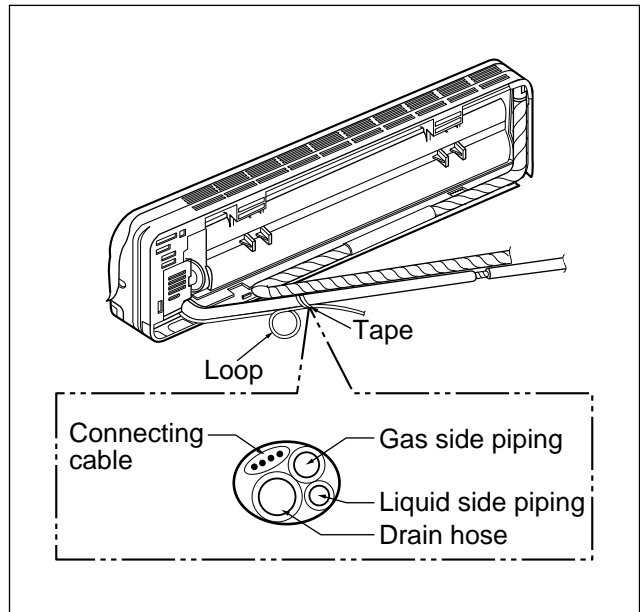

7. Indoor unit installation

- Hook the indoor unit onto the upper portion of the installation plate. (Engage the two hooks of the rear top of the indoor unit with the upper edge of the installation plate.)
Insure the hooks are properly seated on the installation plate by moving it in left and right.

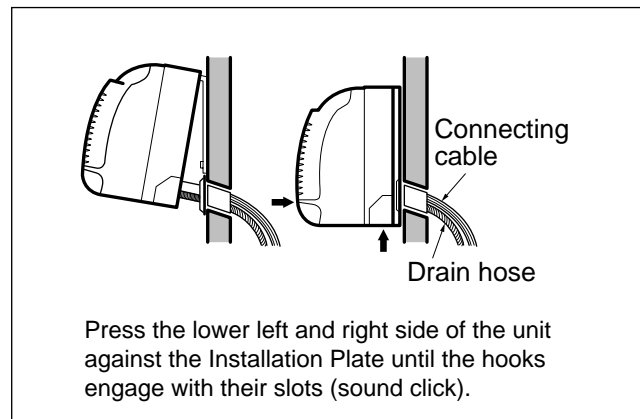

For left rear pipings

3. Route the indoor tubing with the drain hose to the piping hole as desired position.

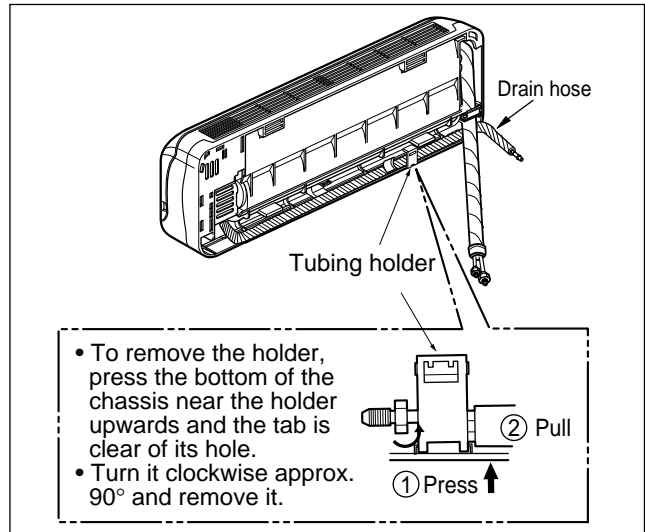

4. Insert the pipings and the connecting cable into the piping hole.

5. Insert the connecting cable into the indoor unit.

- Don't connect the cable to the indoor unit.
- Make a small loop with the cable for easy connection later.

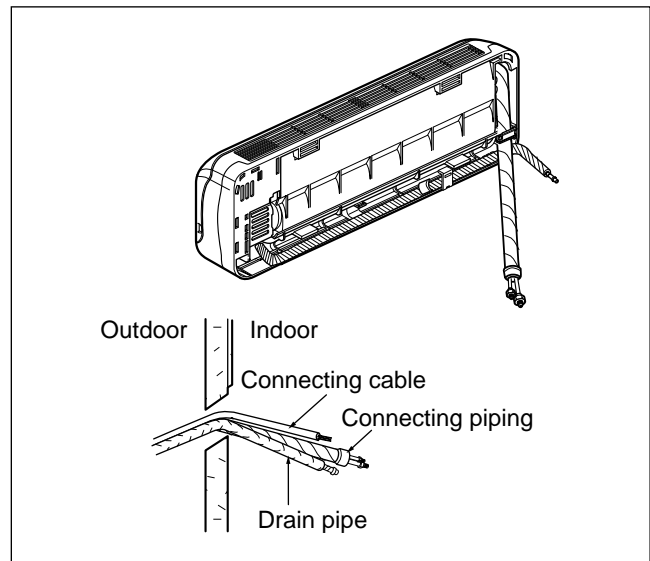

6. Tape the tubing, drain hose and the connecting cable.

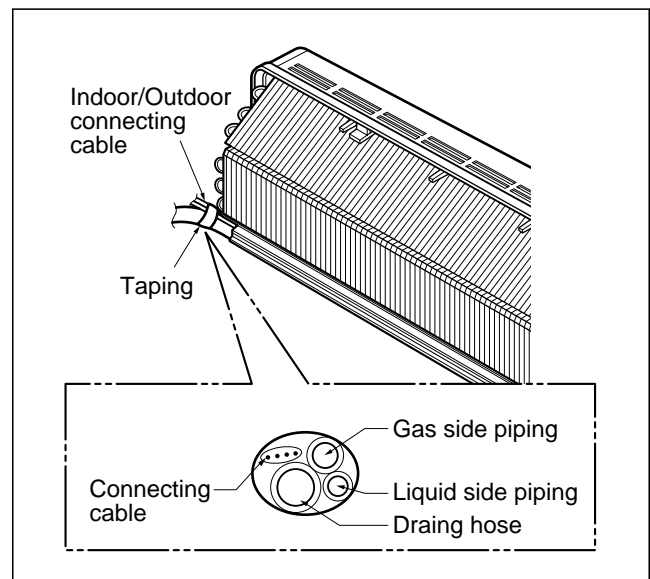

7. Indoor unit installation

- Hook the indoor unit onto the upper position of installation plate. (Engage the two hooks of the rear top of the indoor unit with the upper edge of the installation plate.)
Ensure the hooks are properly seated on the installation plate by moving it in left and right.

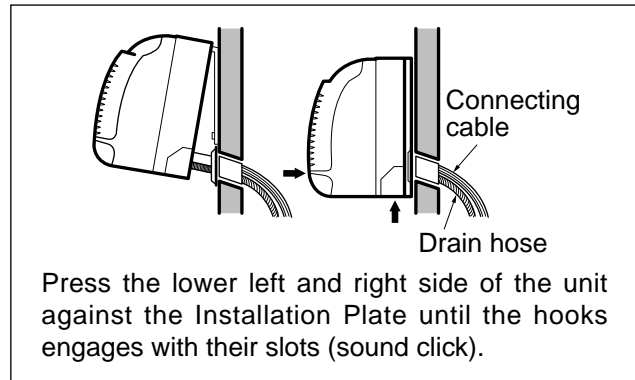

8. Connecting the pipings to the indoor unit

- Align the center of the pipings and sufficiently tighten the flare nut with fingers.
- Finally, tighten the flare nut with torque wrench until the wrench clicks.
Wrench tightening the flare nut with torque wrench, ensure the direction for tightening follows the arrows on the wrench.

Pipe Size	Torque
Liquid Side (1/4")	1.8kg .m
Gas Side (1/2")	5.5kg .m

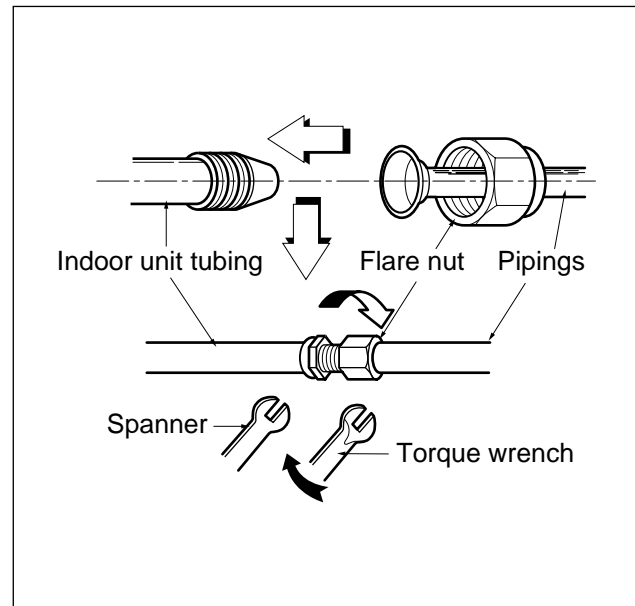

9. Wrap the insulation material around the connecting portion.

CAUTION: Take care to arrange the pipings, drain hose and cables as the right upper picture for inserting it into the indoor unit and refixing the tubing holder easily.

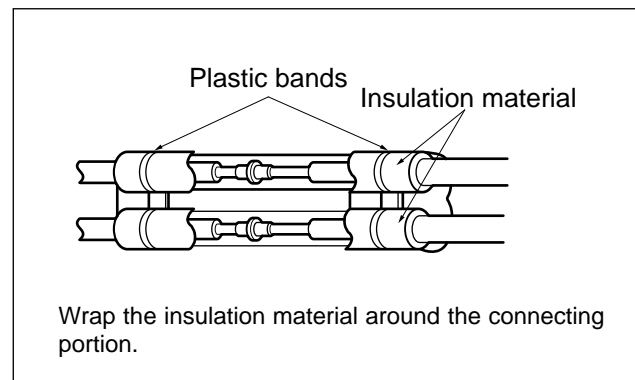

10. Set the pipings and the connecting cable to the back of the chassis with the tubing holder.

- Hook the edge of tubing holder to tap on chassis and push the bottom of tubing holder to be engaged in the bottom of chassis.

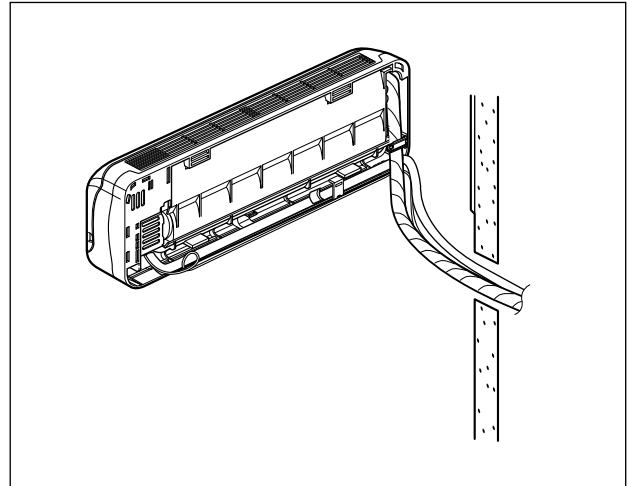

11. Indoor unit installation.

- Hook the indoor unit onto the upper portion of installation plate. (Engage the two hooks of the rear top of the indoor unit with the upper edge of the installation plate.)
Ensure the hooks are properly seated on the installation plate by moving it in left and right.

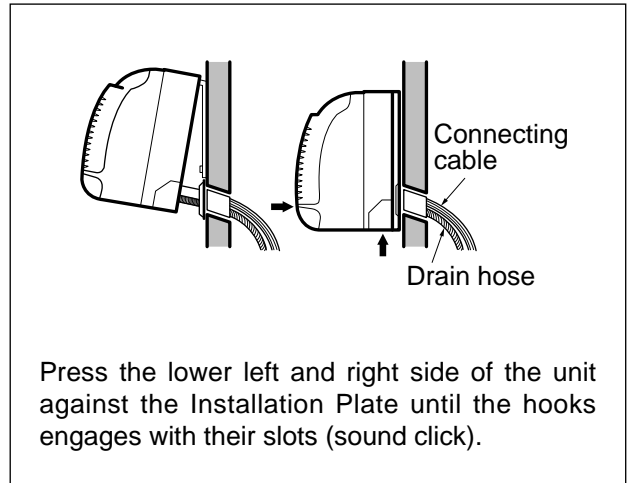

(3) Connecting Pipings and the cable to Outdoor unit

1) Connecting the pipings to the Outdoor unit

1. Align the center of the pipings and sufficiently tighten the flare nut with fingers.
2. Finally, tighten the flare nut with torque wrench until the wrench clicks.
 - When tightening the flare nut with torque wrench, ensure the direction for tightening follows the arrow on the wrench.

Pipe Size	Torque
Liquid Side (1/4")	1.8kg .m
Gas Side (1/2")	5.5kg .m

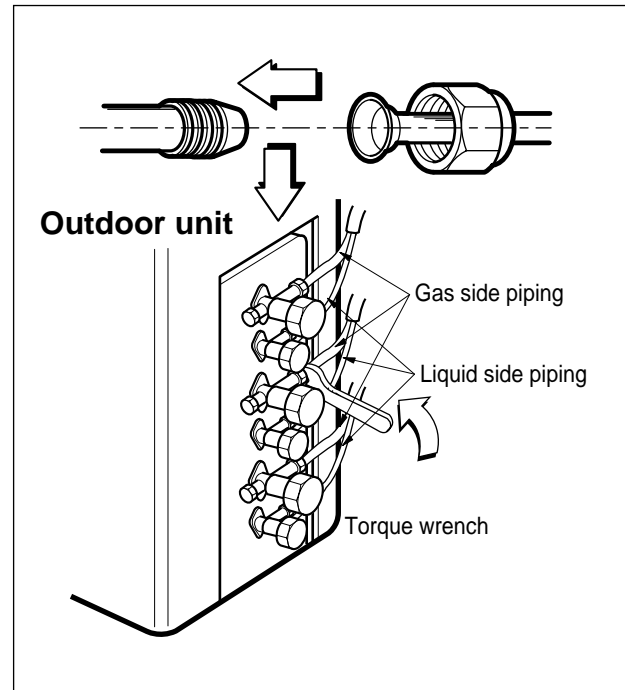

CAUTION

After the confirmation of the above conditions, prepare the wiring as follows:

- 1) Never fail to have an individual power specialized for the air conditioner. As for the method of wiring, be guided by the circuit diagram pasted on the inside of control box cover.
- 2) The means for disconnection from a power supply shall be incorporated in the fixed wiring and have an air gap contact separation of at least 3mm in each active(phase) conductors.
- 3) The screw which fasten the wiring in the casing of electrical fittings are liable to come loose from vibrations to which the unit is subjected during the course of transportation. Check them and make sure that they are all tightly fastened. (If they are loose, it could give rise to burn-out of the wires.)
- 4) Specification of power source.
- 5) Confirm that electrical capacity is sufficient.
- 6) See to that the starting voltage is maintained at more than 90 percent of the rated voltage marked on the name plate.
- 7) Confirm that the cable thickness is as specified in the power sources specification. (Particularly note the relation between cable length and thickness.)
- 8) Never fail to equip a leakage breaker where it is wet or moist.
- 9) The following troubles would be caused by voltage drop-down.
 - Vibration of a magnetic switch, damage on the contact point there of, fuse breaking, disturbance to the normal function of a overload protection device.
 - Proper starting power is not given to the compressor.

2) Connection of the cable

- Remove the cover control from the unit by loosening the screw.
Connect the wires to the terminals on the control board individually as the following.

• LM-2421C2L

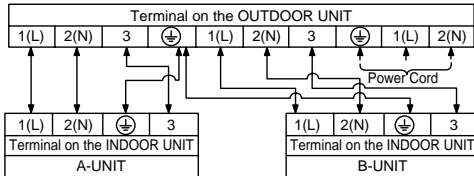

• LM-3022C3L

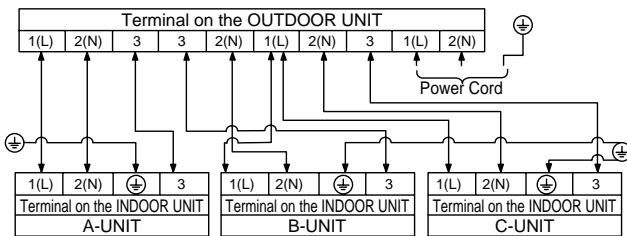

- Secure the cable onto the control board with the holder (clammer).
- Refix the cover control to the original position with the screw.
- Use a recognized circuit breaker between the power source and the unit. A disconnection device to adequately disconnect all supply lines must be fitted.

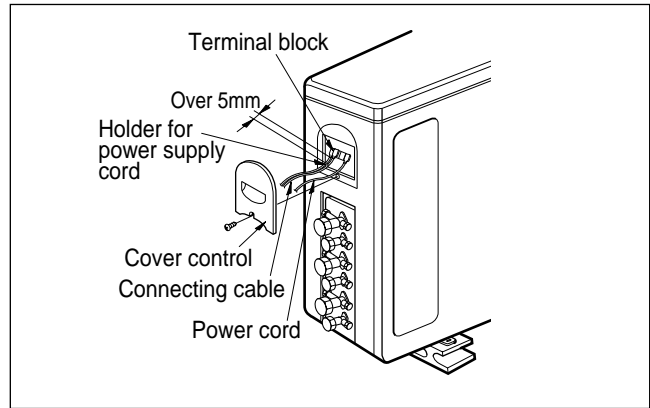

CAUTION

The power cord connected to the outdoor unit should be complied with the following specifications (Rubber insulation, type H05RN-F approved by HAR or SAA).

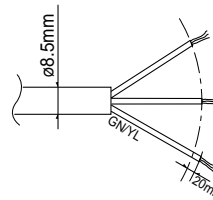

NORMAL CROSS-SECTIONAL AREA
2.5mm²

The connecting cable connected to the indoor and outdoor unit should be complied with the following specifications (Rubber insulation, type H07RN-F approved by HAR or SAA).

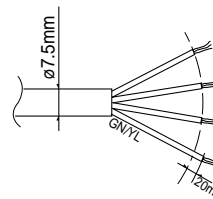

NORMAL CROSS-SECTIONAL AREA
0.75mm²

CAUTION

If a power plug is not to be used, provide a circuit breaker between power source and the unit as shown below.

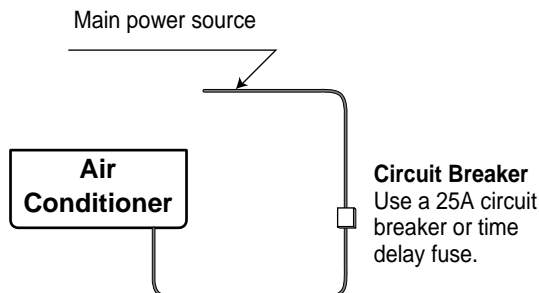

(4) Checking the Drainage and Pipe forming

1) Checking the Drainage

1. Remove the Grille from the cabinet

- Set the up-and-down air direction louver to open position(horizontally) by finger pressure.
- Remove the securing screws.
- To remove the Grille, pull lower the left and right side of the grille toward you (slightly tilted) and lift it straight upward.

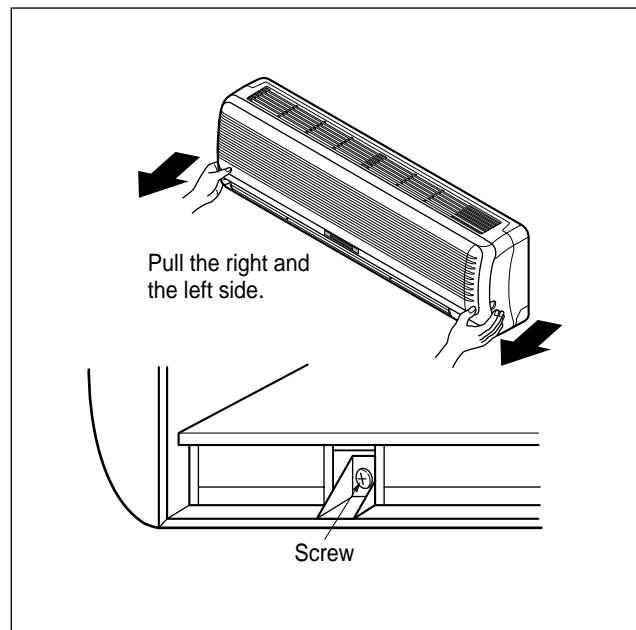

2. Check the drainage

- Pour a glass of water on the evaporator.
- Ensure if water flows drain hose of indoor unit without any leakage.

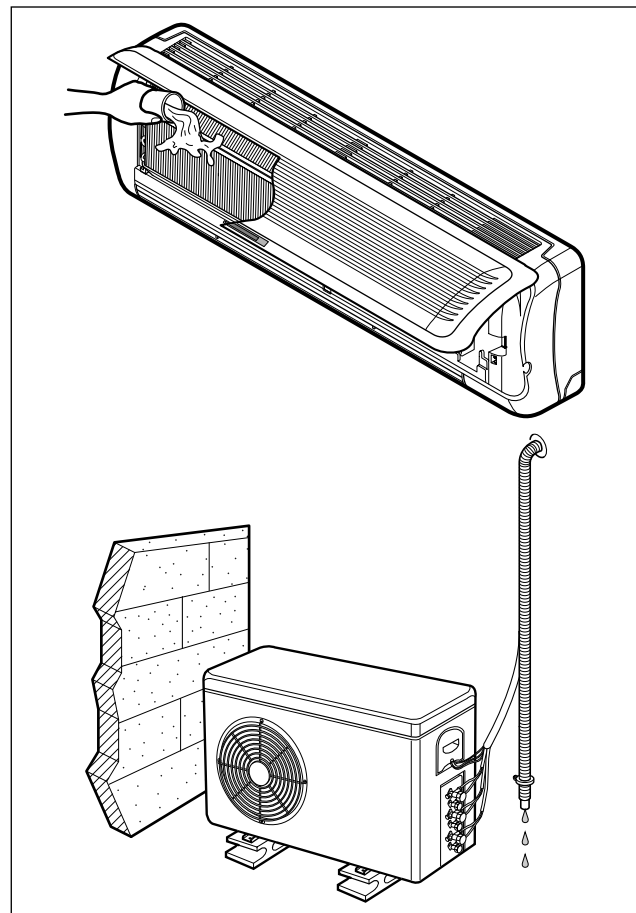

2) Connect the cable to the indoor unit

1. Connect the wires to the terminals on the control board individually according to the outdoor unit connection.

- Ensure that the color of the wires of outdoor unit and the terminal No. are the same as those of indoor unit respectively.

• LM-2421C2L

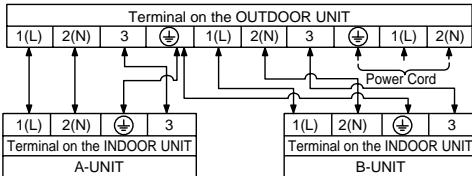

• LM-3022C3L

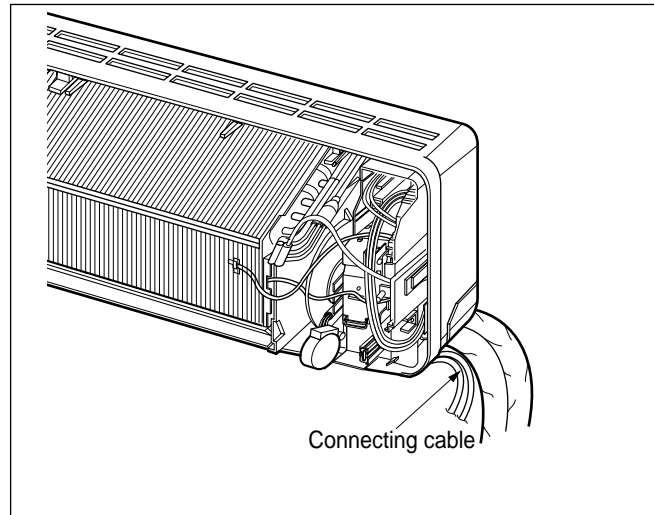
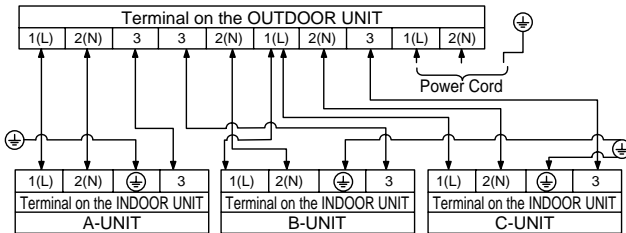

2. Attach the Grille onto the cabinet.

- Grasp lower the left and right side of the Grille and engage four tabs on the top inside edge of the chassis.
- Press the Grille toward the chassis until it will be back into place.

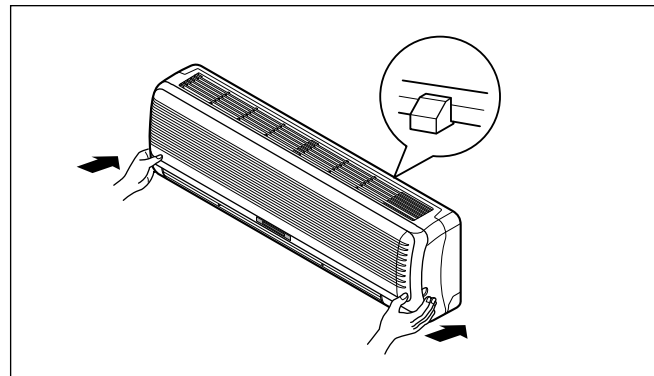

3) Form the pipings

1. Wrap the connecting portion of indoor unit with the Insulation material and secure it with two Plastic Bands (for the right pipings).

- If you want to connect an additional drain hose, the end of the drain-outlet should keep distance from the ground. (Do not dip it into water, and fix it on the wall to avoid swinging in the wind.)

In case of the Outdoor unit is installed below position of the Indoor unit.

2. Tape the Pipings, drain hose and Connecting Cable from down to up.

3. Form the pipings gathered by taping along the exterior wall and fix it onto the wall by saddle or equivalent.

In case of the Outdoor unit is installed upper position of the Indoor unit.

1. Tape the Pipings and Connecting cable from down to up.

2. Form the pipings gathered by taping along the exterior wall and the Trap to be required to prevent the room from entering the water.

3. Fix the pipings onto the wall by saddle or equivalent.

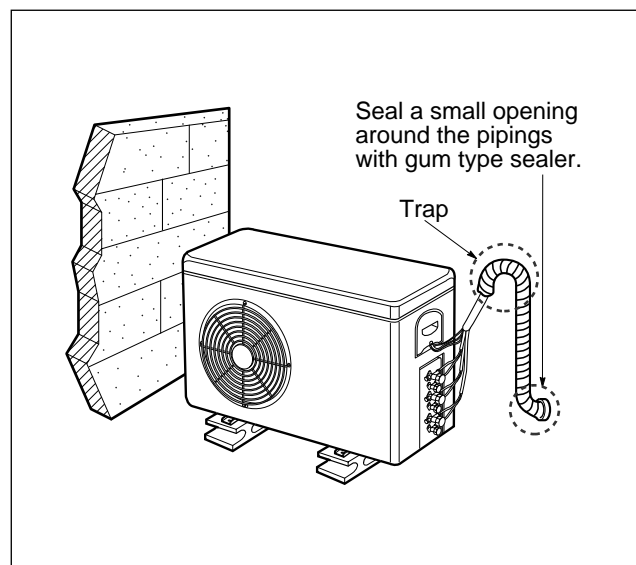
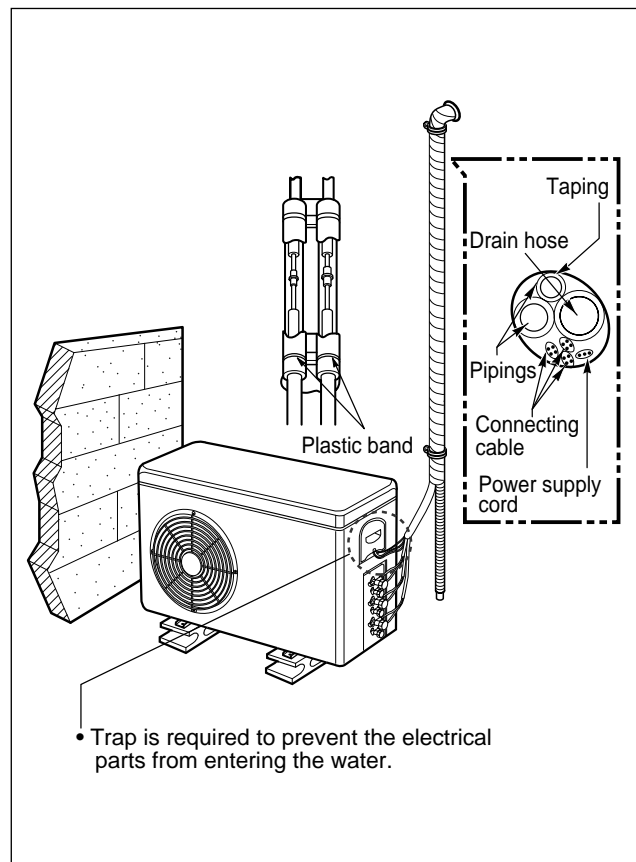

(5) Air Purging of the Pipings and indoor unit

The air which contains moisture remaining in the is refrigeration cycle may cause a malfunction on the compressor.

1. Confirm that both the liquid side valve and the gas side valve are set to the closed position.
2. After connecting the piping, check the joints for gas leakage with gas leak detector.
3. Remove the service port nut, and connect the gauge manifold and the vacuum pump to the service port by the charge hose.
4. Vacuum the indoor unit and the connecting pipes until the pressure in them lowers to below-76cmHg.
5. Disconnect the charge hose and fit the nut to the service port.
(Tightening torque: 1.8kg-m)
6. Remove the valve stem nuts, and fully open the stems of the 2-way and 3-way valves with a hexagon wrench.
7. Tighten the valve stem nuts of the 2-way valve and 3-way valve.

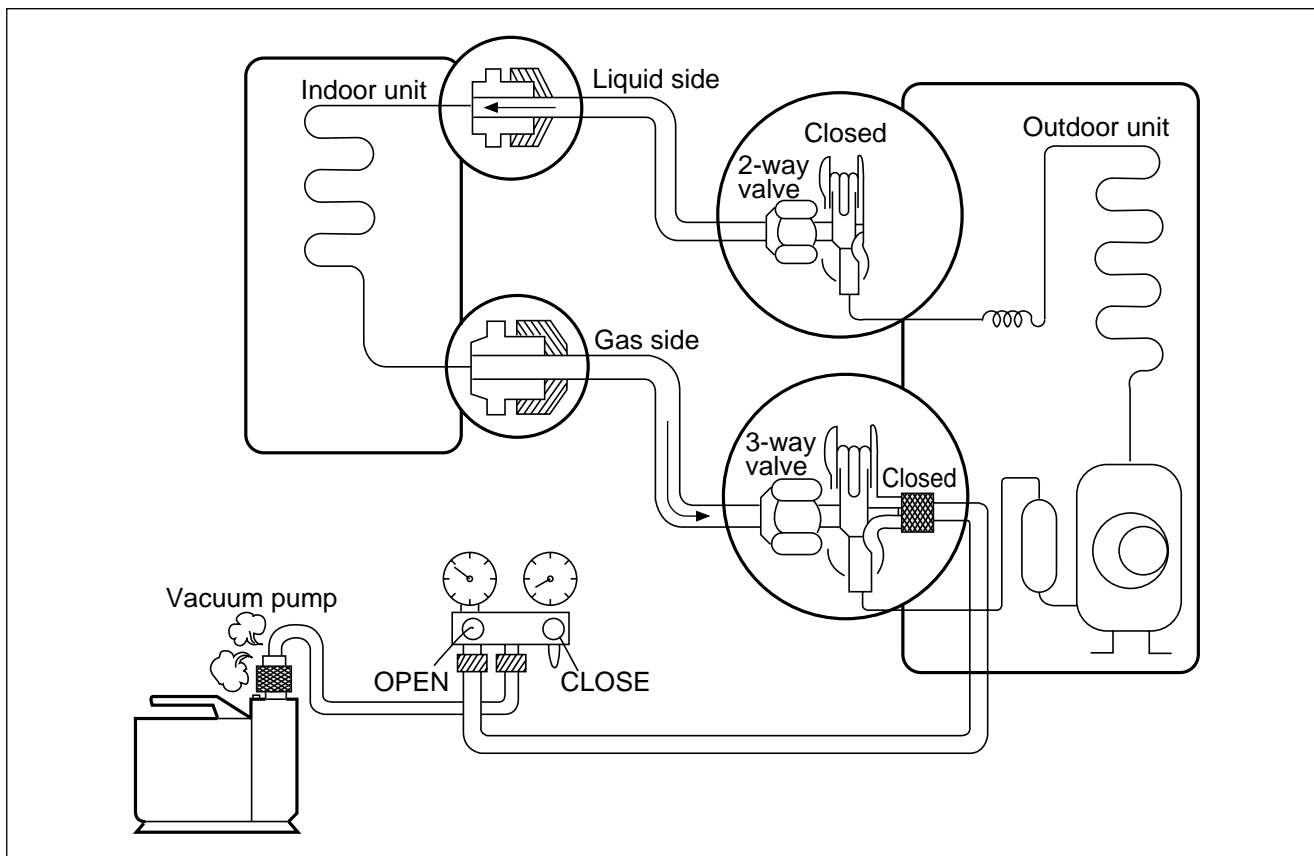

(6) Maximum Length of Pipe and Freon Extra Charge

Charge amount per 1m

Model	STANDARD LENGTH(m)	Maximum Length & Height(m)		Charge am't(g) per 1m
		A	B	
LM-2421C2L	7.5	7	15	30
LM-3022C3L	7.5	7	15	30

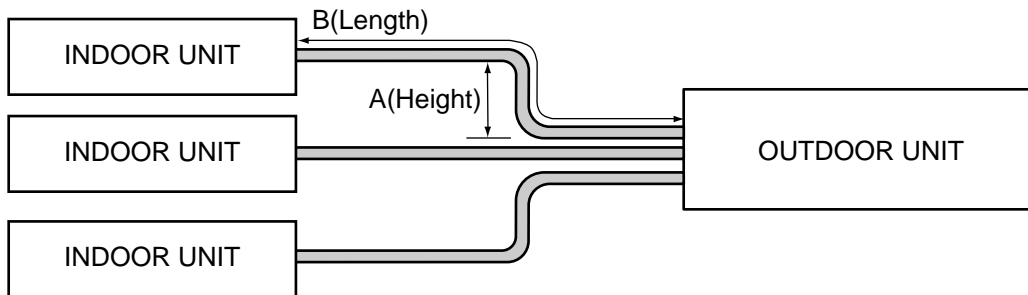

Preventive function of cable mis-connection

This product has a preventive function of cable mis-connection. In case of mis-connection (in case that the cables between indoor and outdoor units have not been connected properly), it gives a warning signal of LED flickering 3 minutes after starting operation. (Press the forced operation key more than 3 seconds.)

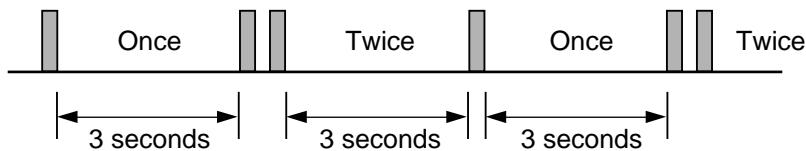

CAUTION

Don't turn on all the indoor units all at once when you check the connection status. In that case the sensor can not be operated properly.

(7) Test running

1) Connection of power supply

1. Connect the power supply cord to the independent power supply.

2. Prepare the remote control.

- Insert two batteries provided.
Remove the battery cover from the remote controller.
- Slide the cover according to the arrow direction.
Insert the two batteries.
(Two "R03" or "AAA" dry-cell batteries or equivalent.)
- Be sure that the (+) and (-) directions are correct.
- Be sure that both batteries are new.
Re-attach the cover.
- Slide it back into position.

3. Operate the unit at cooling operation mode for fifteen minutes or more.

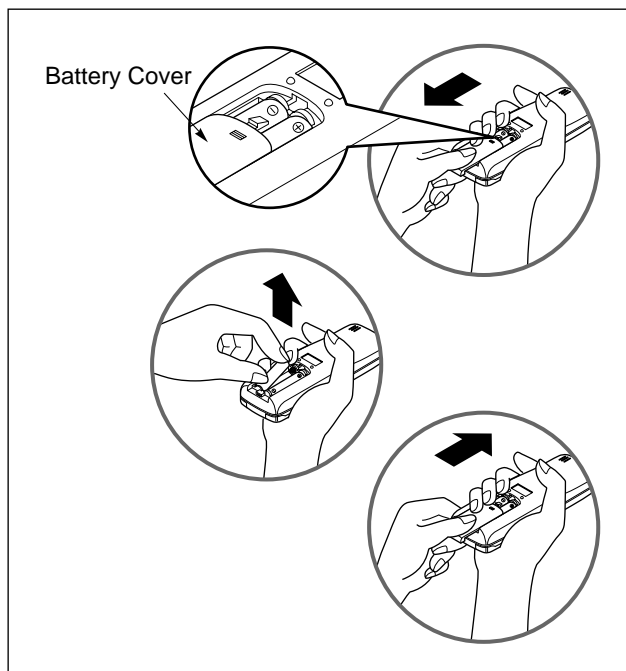

Settlement of Outdoor Unit

- Anchor the outdoor unit with a bolt and nut ($\varnothing 10\text{cm}$) tightly and horizontally on a concrete or rigid mount.
- When installing on the wall, roof or rooftop, anchor the mounting base securely with a nail or wire assuming the influence of wind and earthquake.
- In the case when the vibration of the unit is conveyed to the house, settle the unit with an anti-vibration rubber.

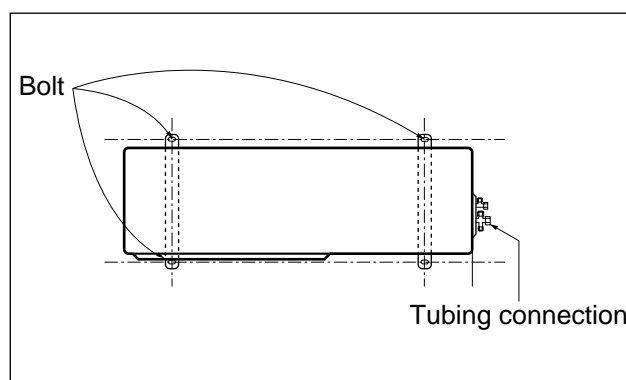

2) Evaluation of the performance

1. Measure the temperature of the intake and discharge air.
2. Ensure the difference between the intake temperature and the discharge one is more than 8°C .

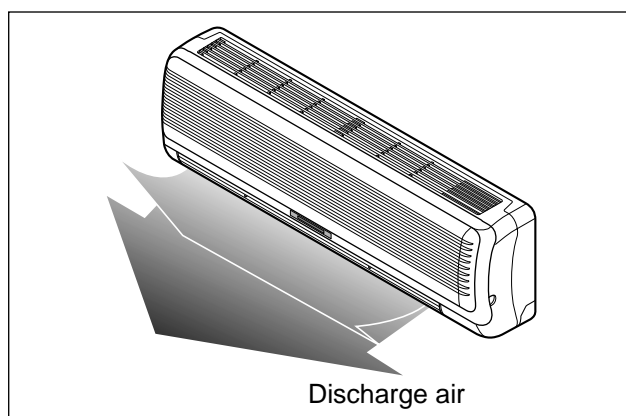

Operation

Name and Function-Remote Control

Remote Control

Signal transmitter

Transmits the signals to the room air conditioner.

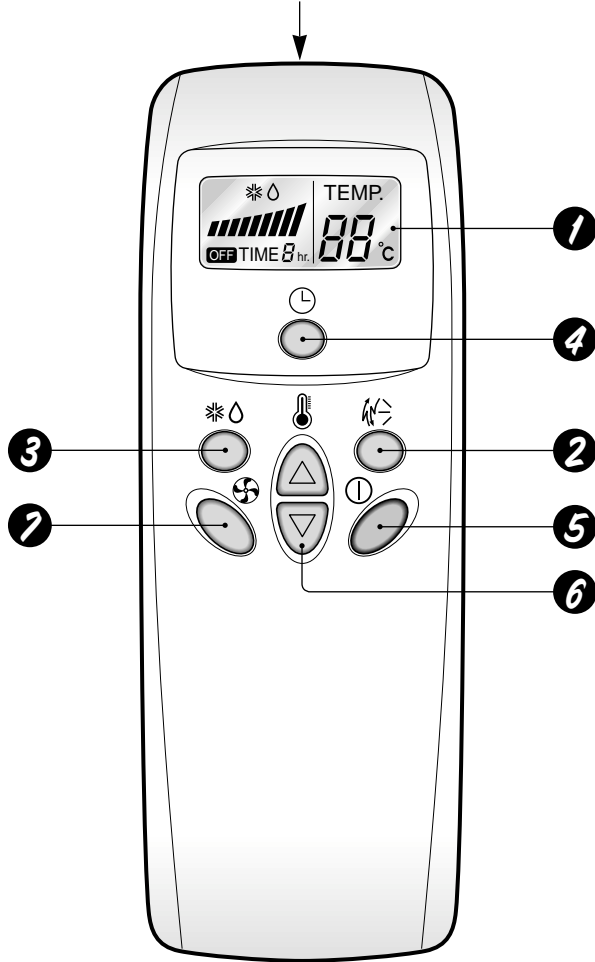

1 OPERATION DISPLAY

Displays the operation conditions.

2 CHAOS SWING BUTTON

Used to stop or start louver movement and set the desired up/down airflow direction.

3 OPERATION MODE SELECTION BUTTON

Used to select the operation mode.

4 OFF TIMER BUTTON

Used to set the time of stopping operation.

5 START/STOP BUTTON

Operation starts when this button is pressed, and stops when the button is pressed again.

6 ROOM TEMPERATURE SETTING BUTTONS

7 INDOOR FAN SPEED SELECTION BUTTON

Disassembly of the parts (Indoor unit)

Warning :

Disconnect the unit from power supply before making any checks.

Be sure the power switch is set to "OFF".

To remove the Grille from the Chassis.

- Set the up-and-down air discharge louver to open position (horizontally) by finger pressure.
- Remove the securing screws
- To remove the Grille, pull the lower left and right side of the grille toward you (slightly tilted) and lift it straight upward.

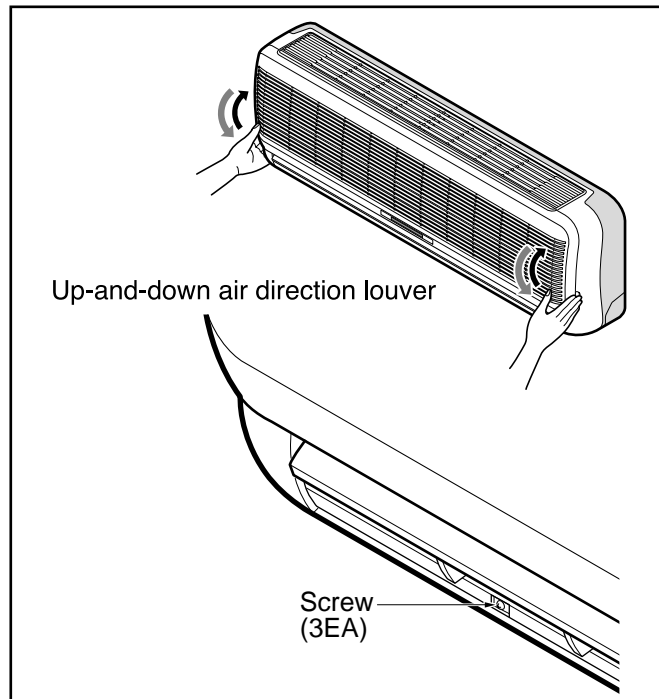

1. To remove the sensor, housing connect, earth conductor & step motor conductor with sensor holder, Motor, Evaporator & P.C.B.

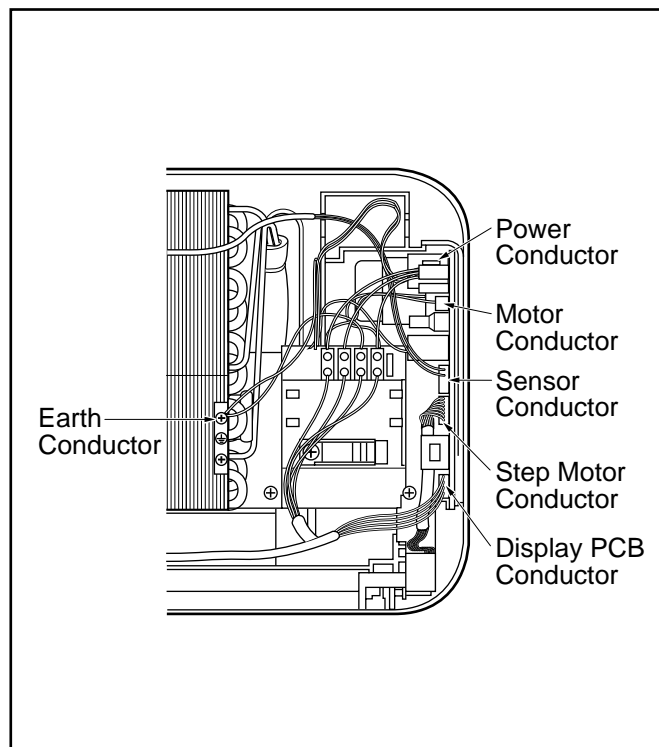

2. To remove the Control Box.

- Remove securing screws.
- Pull the control box out from the chassis carefully.

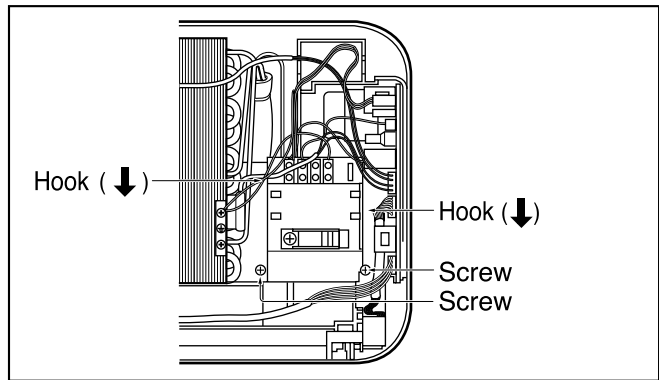

3. To remove the Discharge Grille.

- Pull the discharge grille out from the chassis carefully.

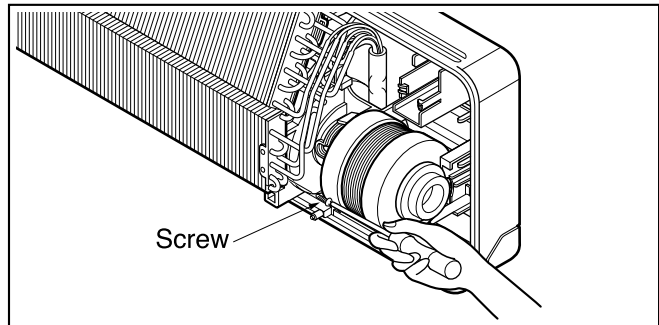

4. To remove the Evaporator.

- Remove screws securing the evaporator and the holder eva.

- Unhook the tab on the right inside of the chassis at the same time, slightly pull the evaporator toward you until the tab is clear of the slot.

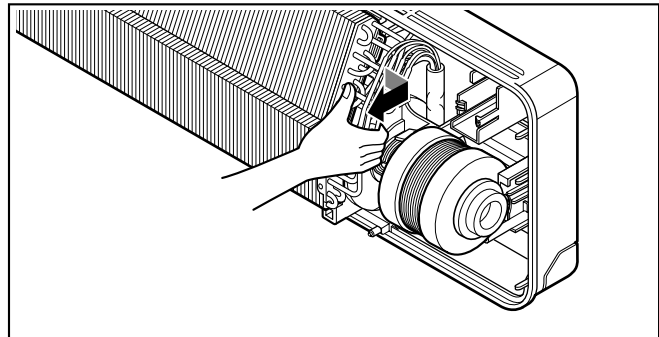

5. To remove the Cross-Flow Fan

- Loosen the screw securing the cross-flow fan to the fan motor (do not remove).
- Lift up the right side of the cross-flow fan and the fan motor, separate the fan motor from the cross-flow fan.

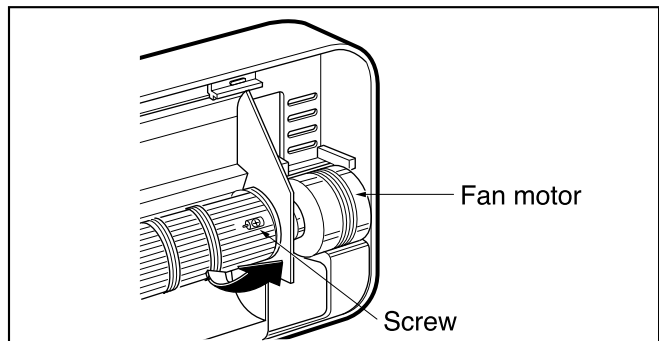

- Remove the left end of the cross-flow fan from the self-aligning bearing.

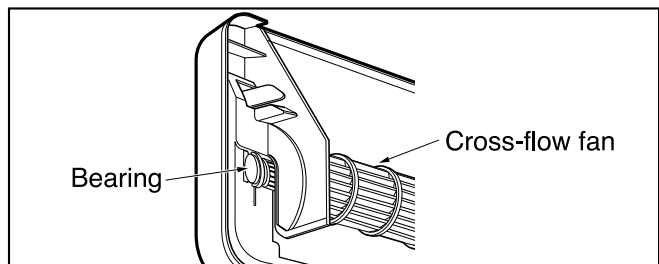

2-way, 3-way Valve

		2-way Valve (Liquid Side)	3-way Valve (Gas Side)	
Works		Shaft position	Shaft position	Service port
Shipping		Closed (with valve cap)	Closed (with valve cap)	Closed (with cap)
1.	Air purging (Installation)	Closed	Closed (clockwise)	Open (for vacuum pump)
Operation		Open (with valve cap)	Open (with valve cap)	Closed (with cap)
2.	Pumping down (Transferring)	Closed (clockwise)	Open (counter-clockwise)	Open (connected manifold gauge)
3.	Evacuation (Servicing)	Open	Open	Open (with vacuum pump)
4.	Gas charging (Servicing)	Open	Open	Open (with charging cylinder)
5.	Pressure check (Servicing)	Open	Open	Open (with charging cylinder)
6.	Gas releasing (Servicing)	Open	Open	Open (with charging cylinder)

(1) Pumping down

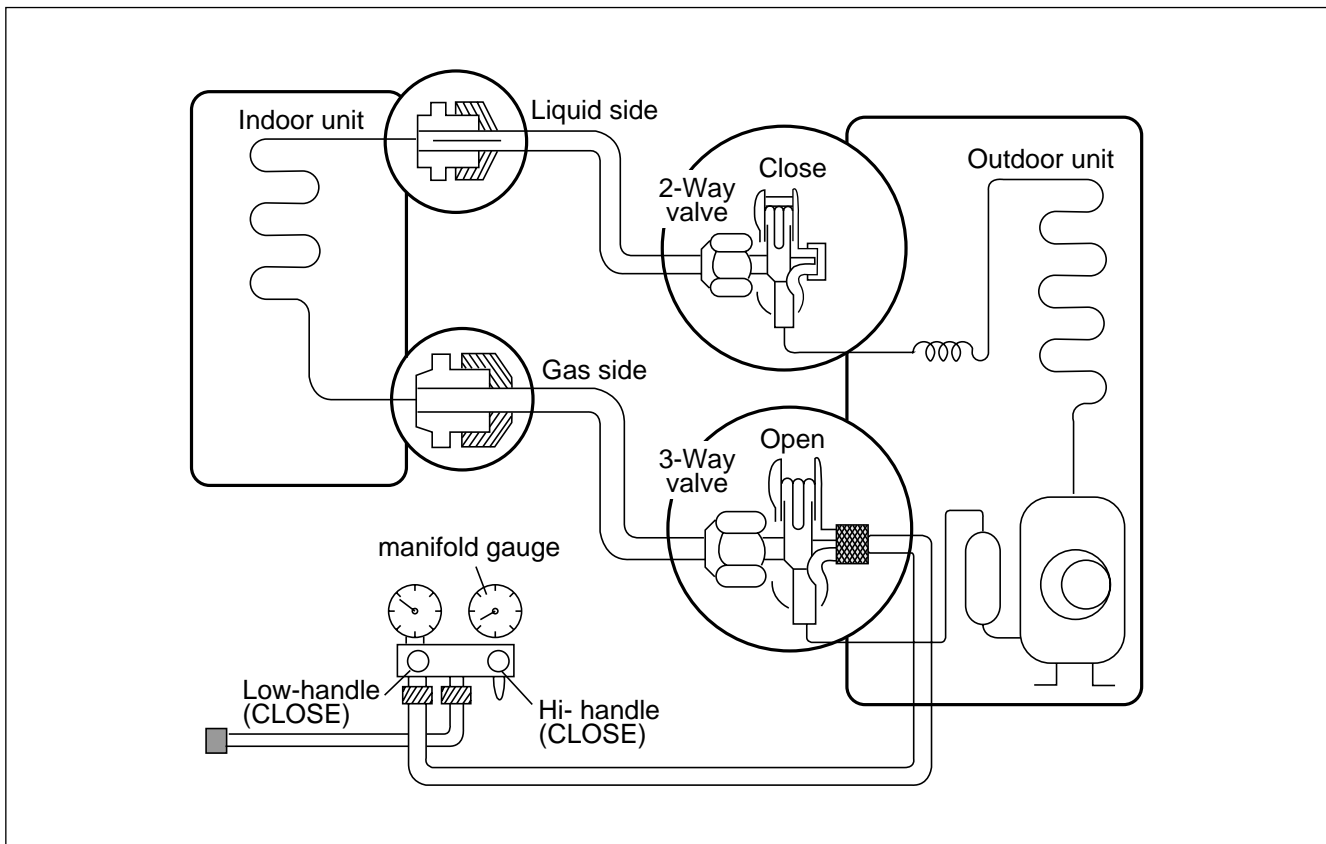

• Procedure

- 1. Confirm that both the gas side and liquid side valves are set to the open position.**
 - Remove the valve stem caps and confirm that the valve stems are in the raised position.
 - Be sure to use a hexagonal wrench to operate the valve stems.
- 2. Operate the unit for 10 to 15 minutes.**
- 3. Stop operation and wait for 3 minutes, then connect the manifold gauge to the service port of the gas side valve.**
 - Connect the hose of the gauge with the push pin to the service port.
- 4. Air purging of the charge hose.**
 - Open the Low-handle valve on the gauge slightly to air purge from the hose.
- 5. Set the liquid side valve to the closed position.**
- 6. Operate the air conditioner at the cooling cycle and stop it when the gauge indicates 1kg/cm²g.**
- 7. Immediately set the gas side valve to the closed position.**
 - Do this quickly so that the gauge ends up indicating 1kg/cm²g.
- 8. Disconnect the charge set, and mount the liquid side and gas side valve caps and the service port nut.**
 - Use torque wrench to tighten the service port nut to a torque of 1.8kg.m.(4.2kg.m/5.5kg.m)
 - Be sure to check for gas leakage.
- 9. Apply steps from 1 to 8 to each unit (A-unit, B-unit) by the same method.**

(2) Evacuation

(All amount of refrigerant leaked)

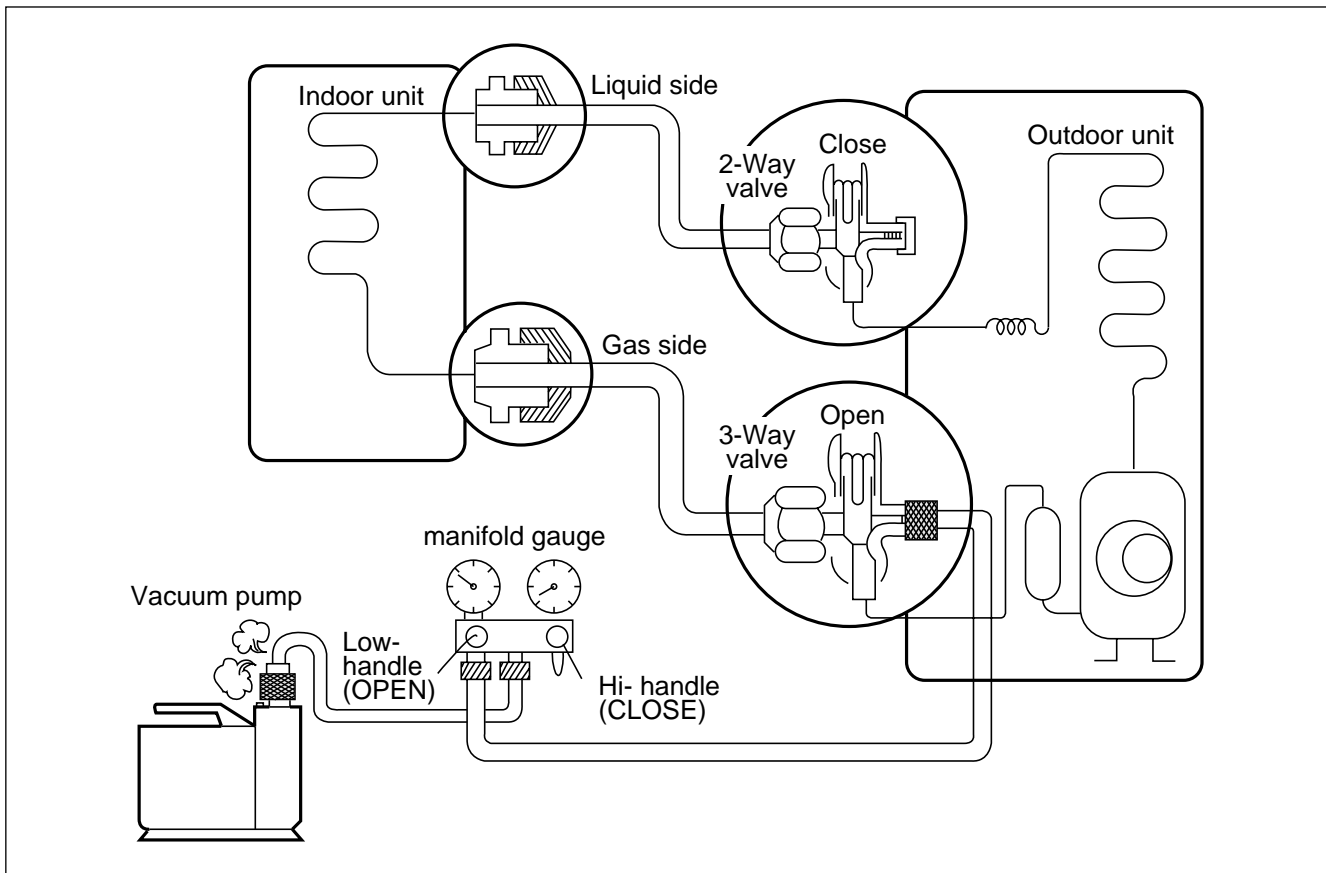

• Procedure

1. Confirm that both the liquid side valve and gas side valve are set to the opened position.
2. Connect the vacuum pump to the center hose of the manifold gauge.
3. Connect the service port of the gas side valve to the low side of the gauge.
4. Evacuation for approximately one hour.
 - Confirm that the gauge needle has moved toward -76 cmHg (vacuum of 4 mmHg or less).
5. Close the Low handle of the gauge, turn off the vacuum pump, and confirm that the gauge needle does not move (approximately 5 minutes after turning off the vacuum pump).
6. Disconnect the charge hose from the vacuum pump.
 - Vacuum pump oil.
 - If the vacuum pump oil becomes dirty or depleted, replenish as needed.
7. Mount the valve caps and the service port caps.
8. Apply steps from 1 to 7 to each unit (A-unit, B-unit) by the same method.

(3) Gas Charging (After Evacuation)

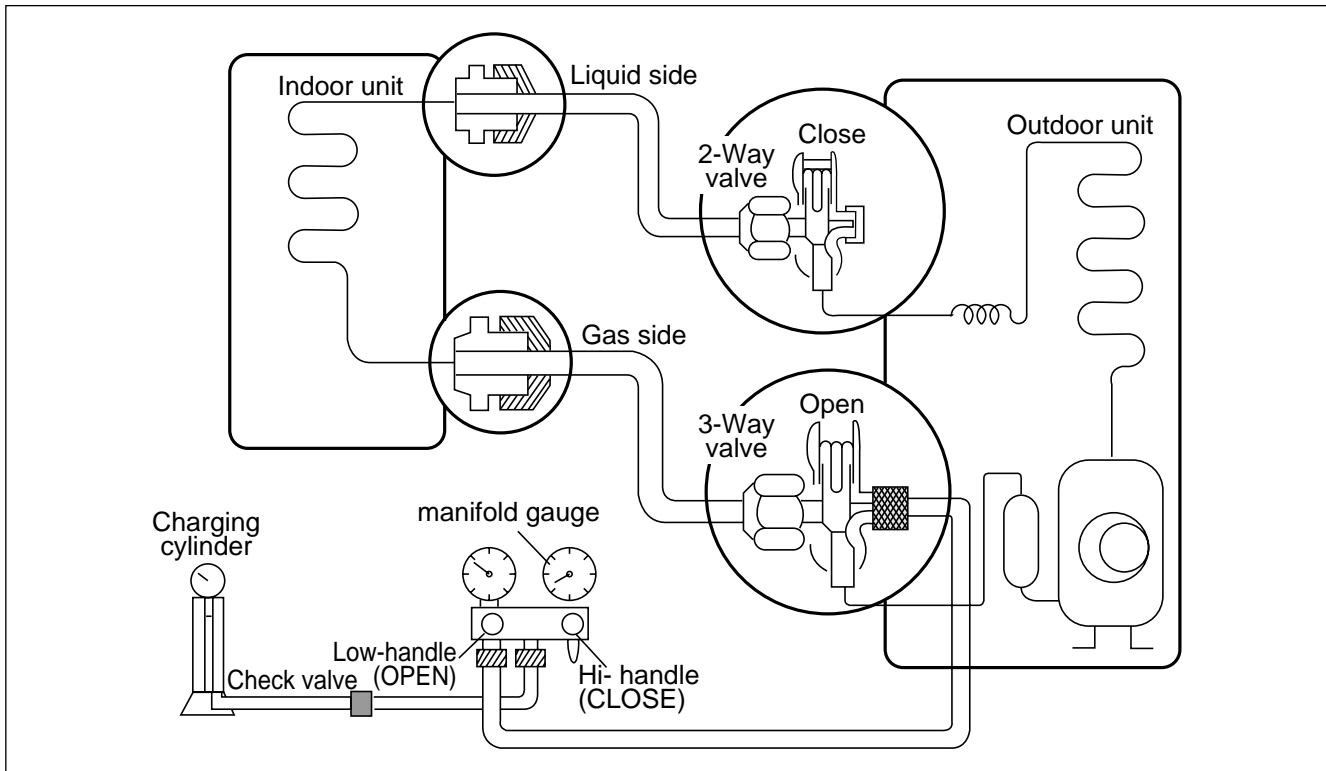

• Procedure

1. Connect the gauge to the charging cylinder.

- Connect the charge hose which you disconnected from the vacuum pump to the valve at the bottom of the cylinder.
- If you are using a gas cylinder, also use a scale and reverse the cylinder so that the system can be charged with liquid.

2. Purge the air from the charge hose.

- Open the valve at the bottom of the cylinder and press the check valve on the charge set to purge the air. (Be careful of the liquid refrigerant). The procedure is the same if using a gas cylinder.

3. Open the low handle on the gauge and charge the system with liquid refrigerant.

- If the system can not be charged with the specified amount of refrigerant, it can be charged with a little at a time (approximately 150g each time) while operating the air conditioner in the cooling cycle; however, one time is not sufficient, wait approximately 1 minute and then repeat the procedure(pumping down-pin).

4. Immediately disconnect the charge hose from the gas side valve's service port.

This is different from previous procedures. Because you are charging with liquid refrigerant from the gas side, absolutely do not attempt to charge with larger amounts of liquid refrigerant while operating the air conditioner.

Cycle Troubleshooting Guide

Trouble analysis

- Check temperature difference between intake and discharge air and operating current.

Temp. Difference	Temp. difference : approx. 0°C Current : less than 80% of rated current	All amount of refrigerant leaked out. Check refrigeration cycle.
	Temp. difference : approx. 8°C Current : less than 80% of rated current	Refrigerant leakage Clog of refrigeration cycle Defective compressor
Operating Current	Temp. difference : less than 8°C Current : over the rated current	Excessive amount of refrigerant
	Temp. difference : over 8°C	Normal

Notice:

Temperature difference between intake and discharge air depends on room air humidity. When the room air humidity is relatively higher, temperature difference is smaller. When the room air humidity is relatively lower temperature difference is larger.

- Check temperature and pressure of refrigeration cycle.

Suction pressure (Compared with the normal value)	Temperature (Compared with the normal value)	Cause of Trouble	Description
Higher	High	Defective compressor	Current is low.
	Normal	Excessive amount of refrigerant	High pressure does not quickly rise at the beginning of operation.
Lower	Higher	Insufficient amount of refrigerant(Leakage) Clogging	Current is low. Current is low.

Notice:

1. The suction pressure is usually 4.5~6.0 kg/cm²G at normal condition.
2. The temperature can be measured by attaching the thermometer to the low pressure tubing and wrap it with putty.

**When product is operating normally, but there is no cool air from all three indoor unit.
Check as follows.(LM-3022C3L)**

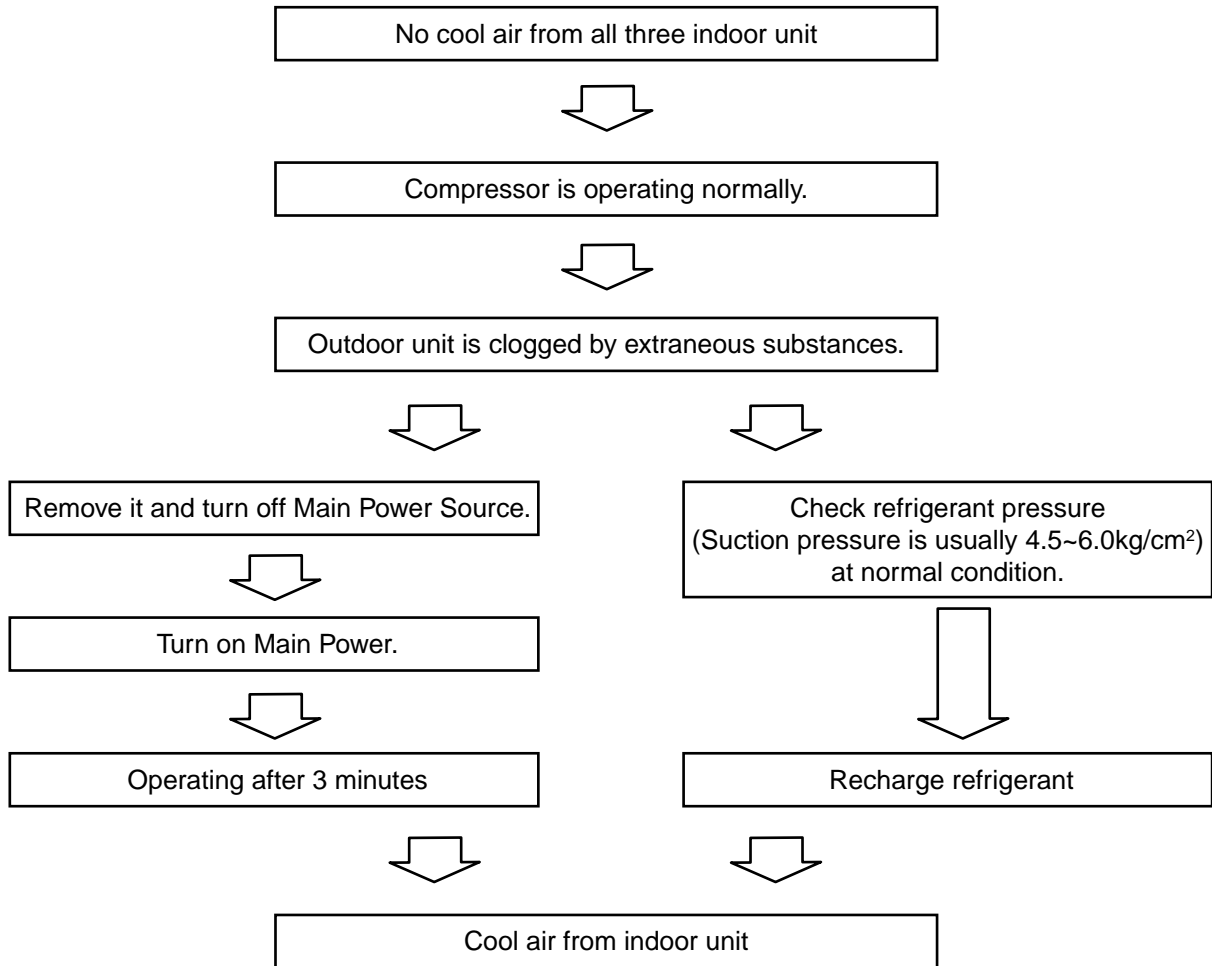

Electronic Parts Troubleshooting Guide

1. Product does not operate at all.

(* Refer to Electronic Control Device drawing and Schematic diagram.)

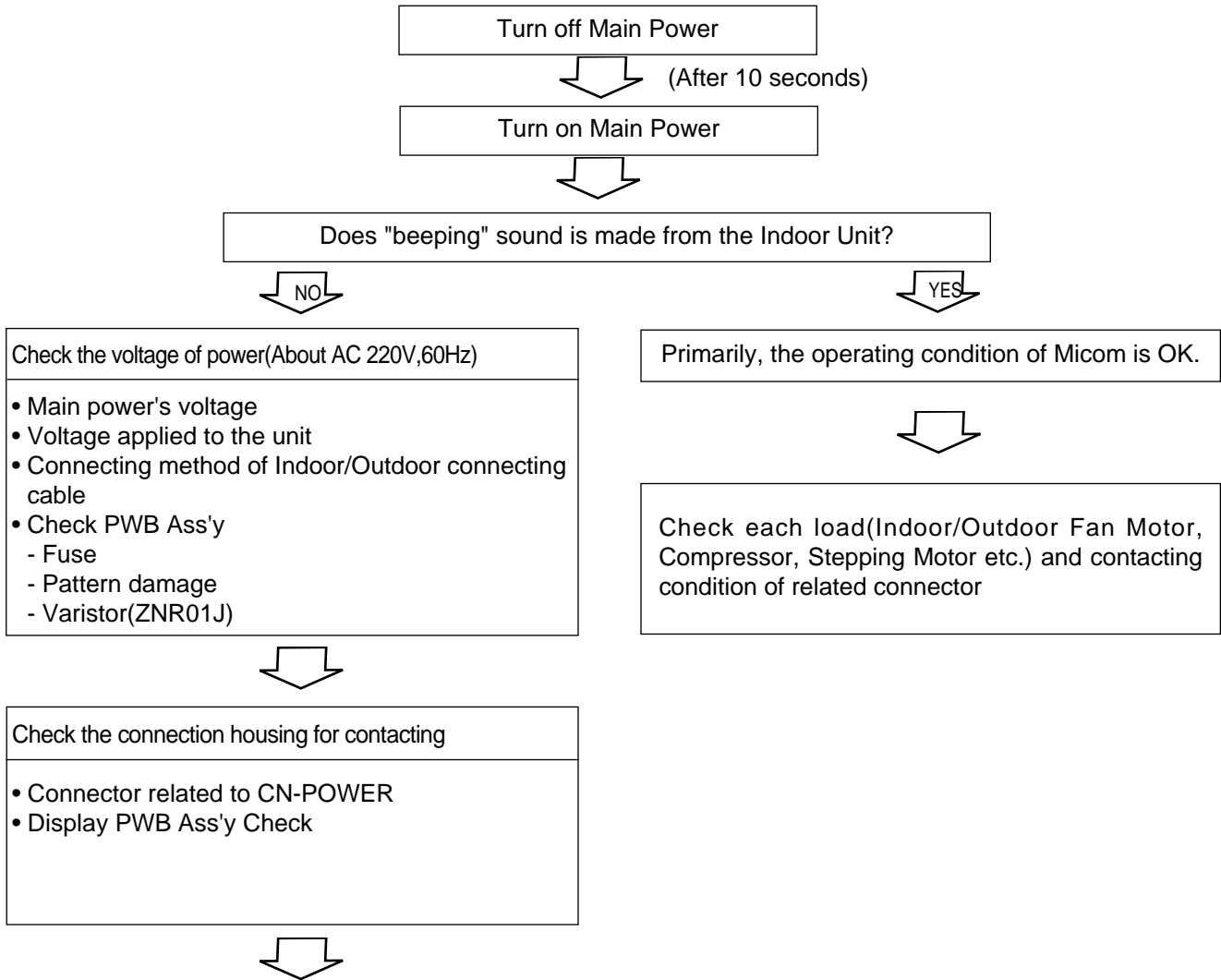

PCB Board Operation Check		
Items	Content	Remedy
<ul style="list-style-type: none"> • Power Transformer (Outdoor unit) - Input Voltage - Output Voltage 	<ul style="list-style-type: none"> - About AC220V±10% - Check the power voltage - About AC14±3V 	<ul style="list-style-type: none"> • Replace Trans
<ul style="list-style-type: none"> • IC01D(7812) Output (Indoor/Outdoor unit) 	<ul style="list-style-type: none"> • DC +12V 	<ul style="list-style-type: none"> • Replace IC01D
<ul style="list-style-type: none"> • IC02D(7805) Output (Indoor/Outdoor unit) 	<ul style="list-style-type: none"> • DC +5V 	<ul style="list-style-type: none"> • Replace IC02D
<ul style="list-style-type: none"> • IC01A(KIA7036, Reset IC) X01(8MHz) 	<ul style="list-style-type: none"> • Voltage of Micom No. 2, (DC +4.5V over) and Soldering condition. 	<ul style="list-style-type: none"> • Replace faulty parts

2. The product is not operate with the remote control.

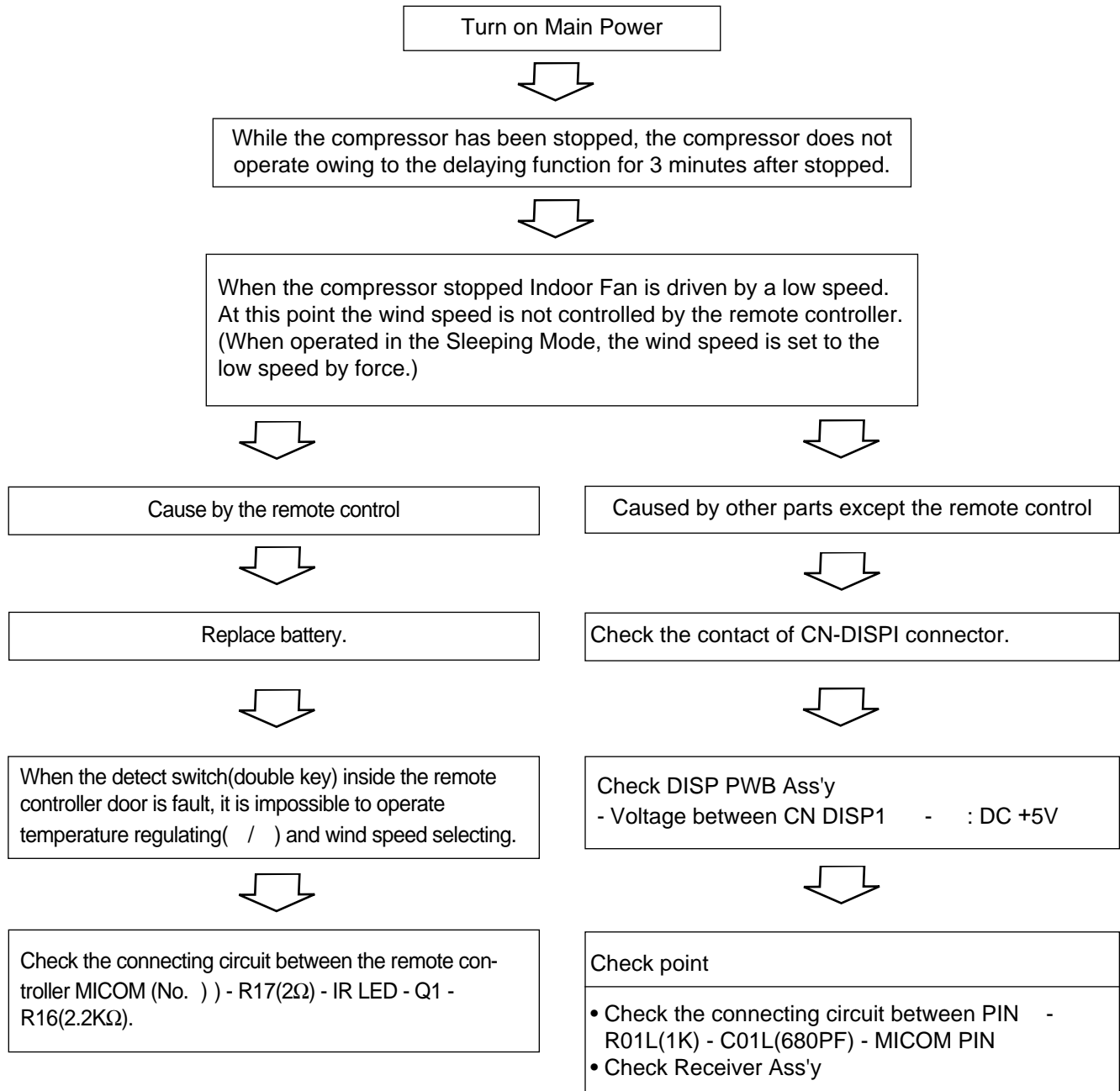

3. When cooling does not operate

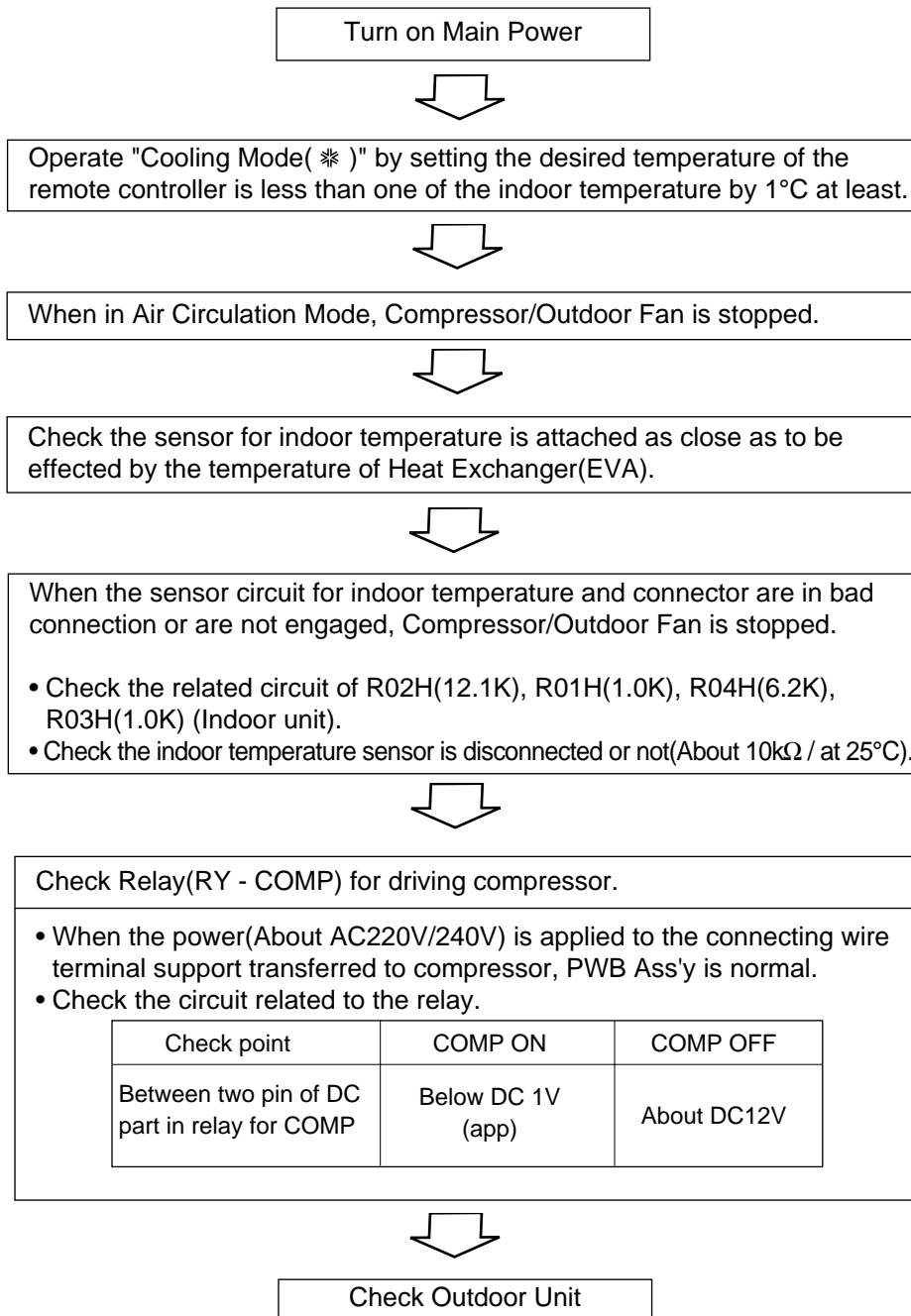

4. When indoor Fan does not operate.

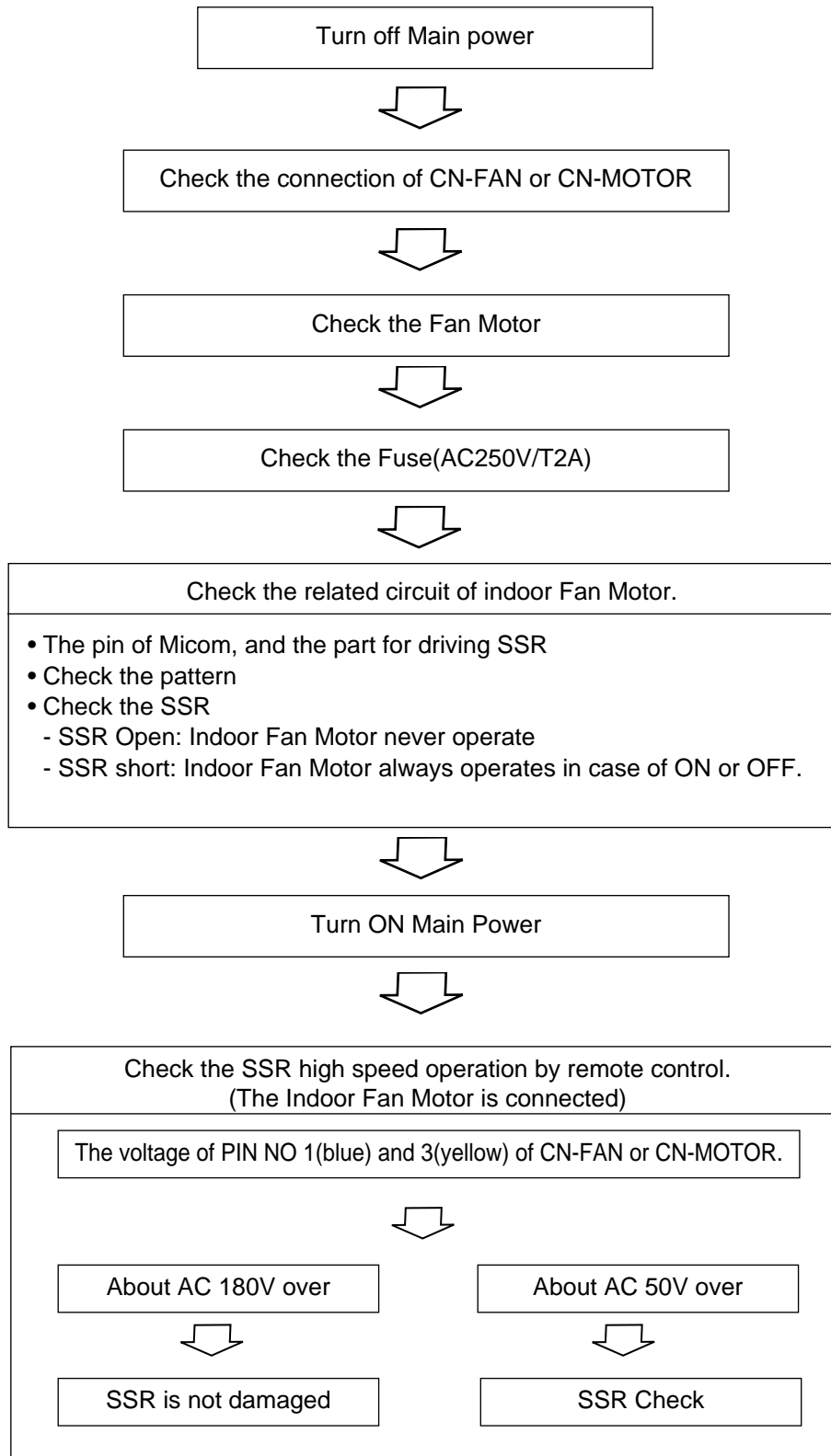

5. When Vertical Louver does not operate.

- Confirm that the Vertical Louver is normally geared with the shaft of Stepping Motor.
- If the regular torque is detected when rotating the Vertical Louver with hands Normal



- Check the connecting condition of CN-U/D Connector
- Check the soldering condition(on PWB) of CN-U/D Connector



Check the operating circuit of the Vertical Louver

- Confirm that there is DC +12V between pin (RED) of CN-U/D and GND.



If there are no problems after above checks

- Confirm the assembly conditions that are catching and interfering parts in the rotation radial of the Vertical Louver

6. Outdoor unit does not operate at all.

Check Outdoor Unit



PCB Board Operation Check in Outdoor		
Items	Content	Remedy
<ul style="list-style-type: none"> • Power Transformer (Outdoor unit) - Input Voltage - Output Voltage ⚡ • IC01D(7812) Output (Indoor/Outdoor unit) ⚡ • IC02D(7805) Output (Indoor/Outdoor unit) ⚡ • IC01A(KIA7036, Reset IC) X01(8MHz) 	<ul style="list-style-type: none"> - About AC220V/240V±10% - Check the power voltage - About AC14±3V • DC +12V • DC +5V 	<ul style="list-style-type: none"> • Replace Trans • Replace IC01D • Replace IC02D • Replace faulty parts



Turn off Main Power



- Check the electrical wiring diagram of outdoor side.
- Check the abnormal condition for the component of Compressor/Outdoor Fan Motor/4-way.
- Check the “open” or “short” of connecting wires between indoor and outdoor.

7. Communication error

- The control data can be transmitted or received between indoor and outdoor unit with one signal cable.
- If the data be disturbed by any noise level, the unit will be operated incorrectly. In this case, the indoor unit blinks the operation and operation LED on display and indoor fan, outdoor fan, COMP are not operated.
- The unit can be reoperated by On/Off control of Remocon.

Electronic Control Device

1. Indoor (LM-2421C2L, LM-3022C3L)

MAIN P.C.B ASSY

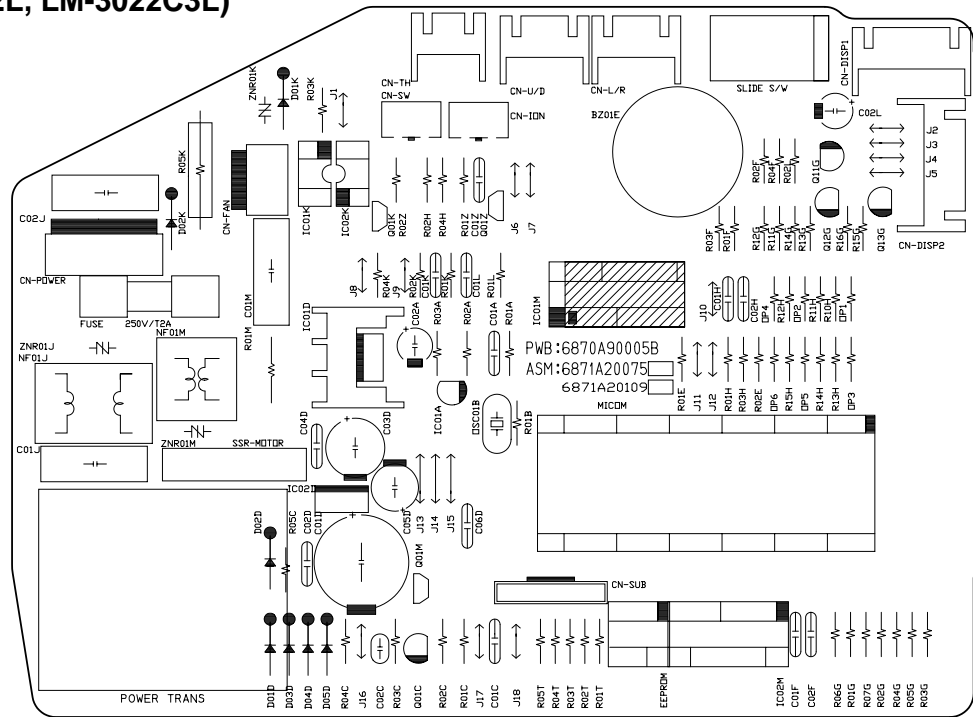

2. Outdoor (LM-2421C2L, LM-3022C3L)

MAIN P.C.B ASSY

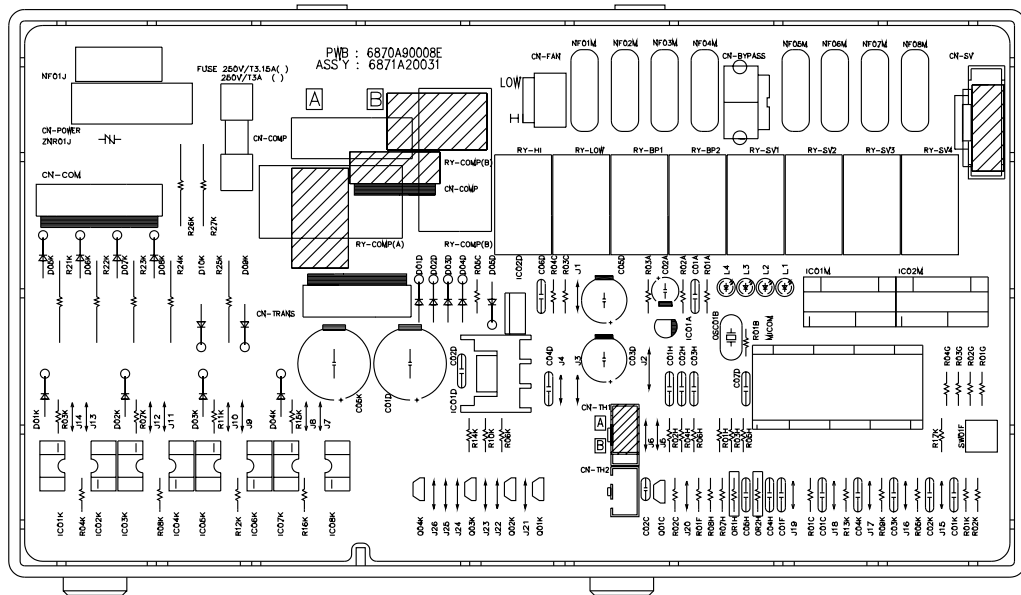

3. DISPLAY P.C.B ASSY (LM-2421C2L, LM-3022C3L)

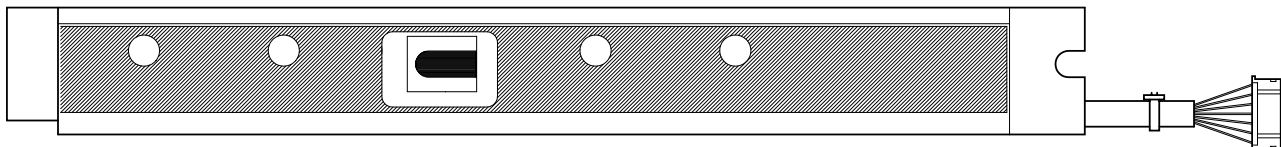

Schematic Diagram

1. Indoor (LM-2421C2L, LM-3022C3L)

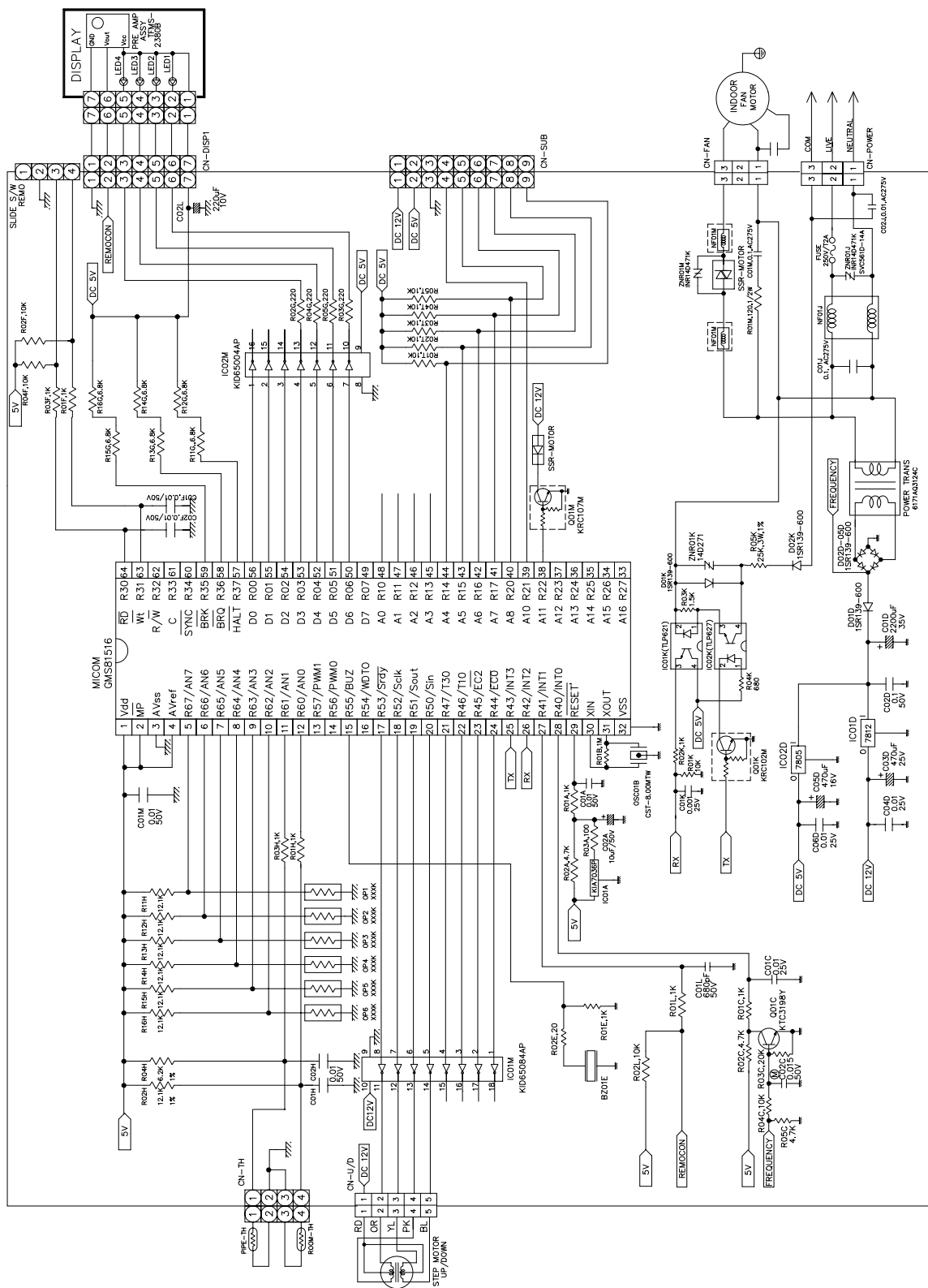

2. Outdoor 2-1. LM-2421C2L

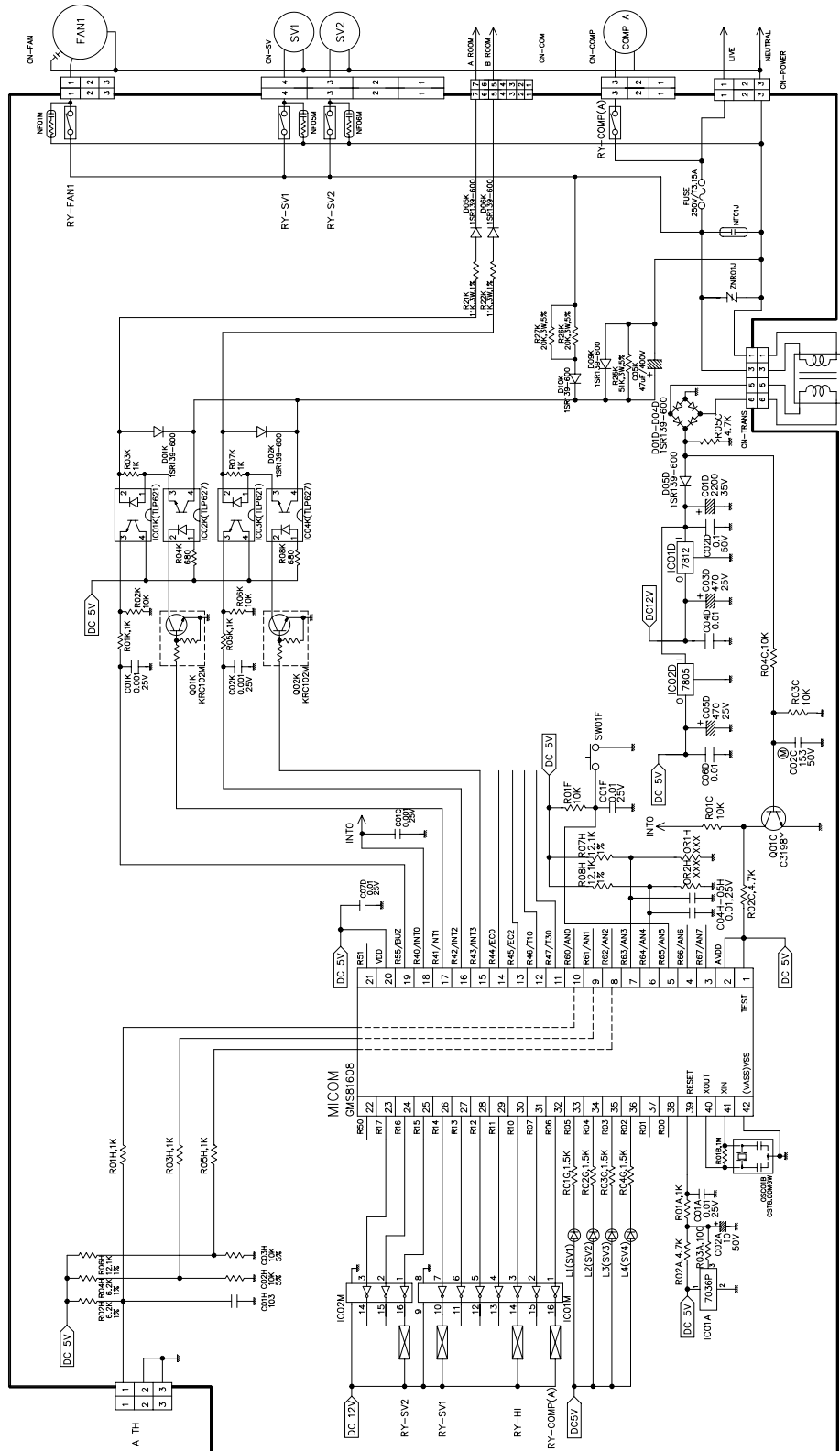

2-2. LM-3022C3L

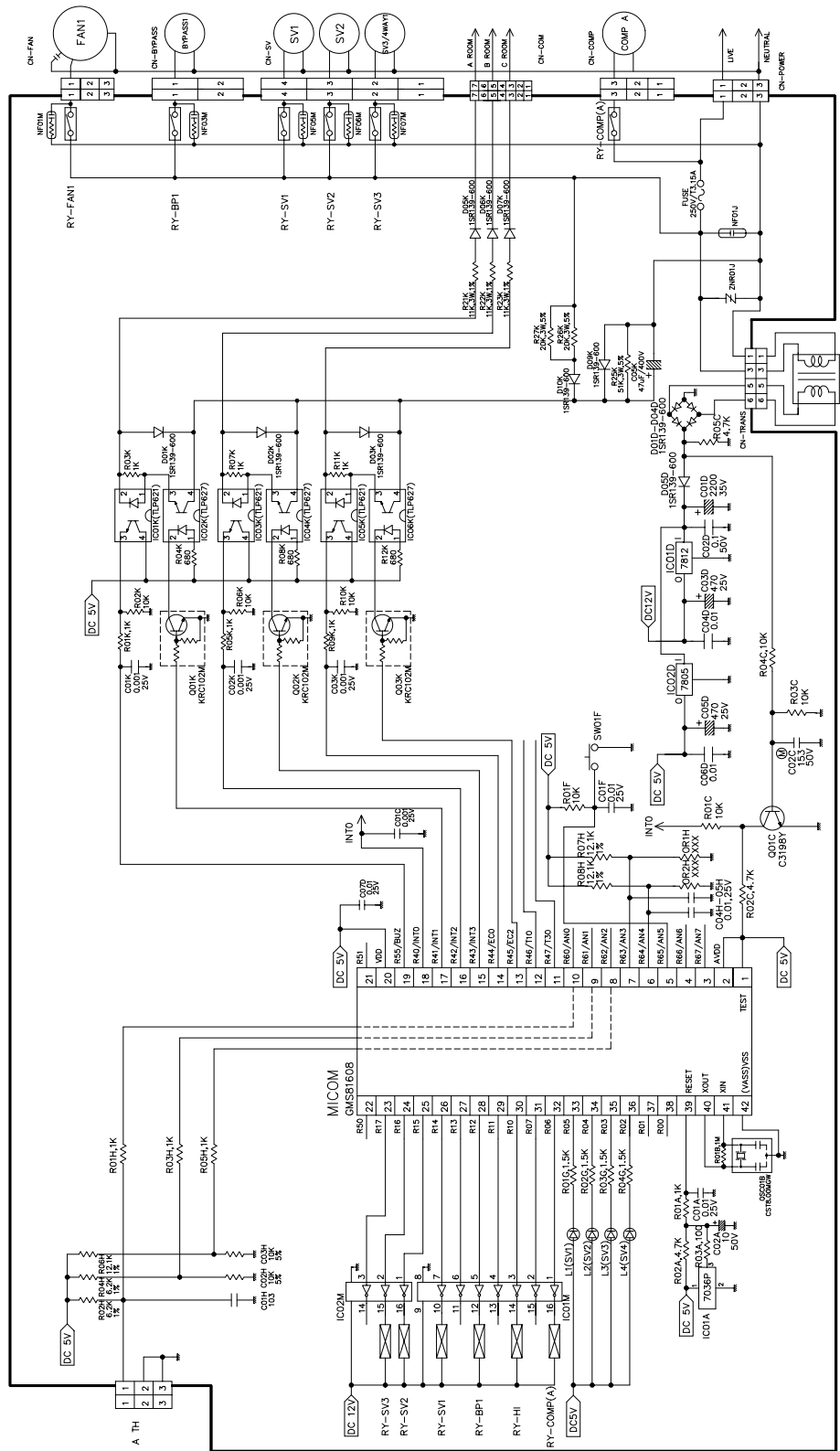

Exploded View & Replacement Parts List

1. Indoor Unit (LM-2421C2L, LM-3022C3L)

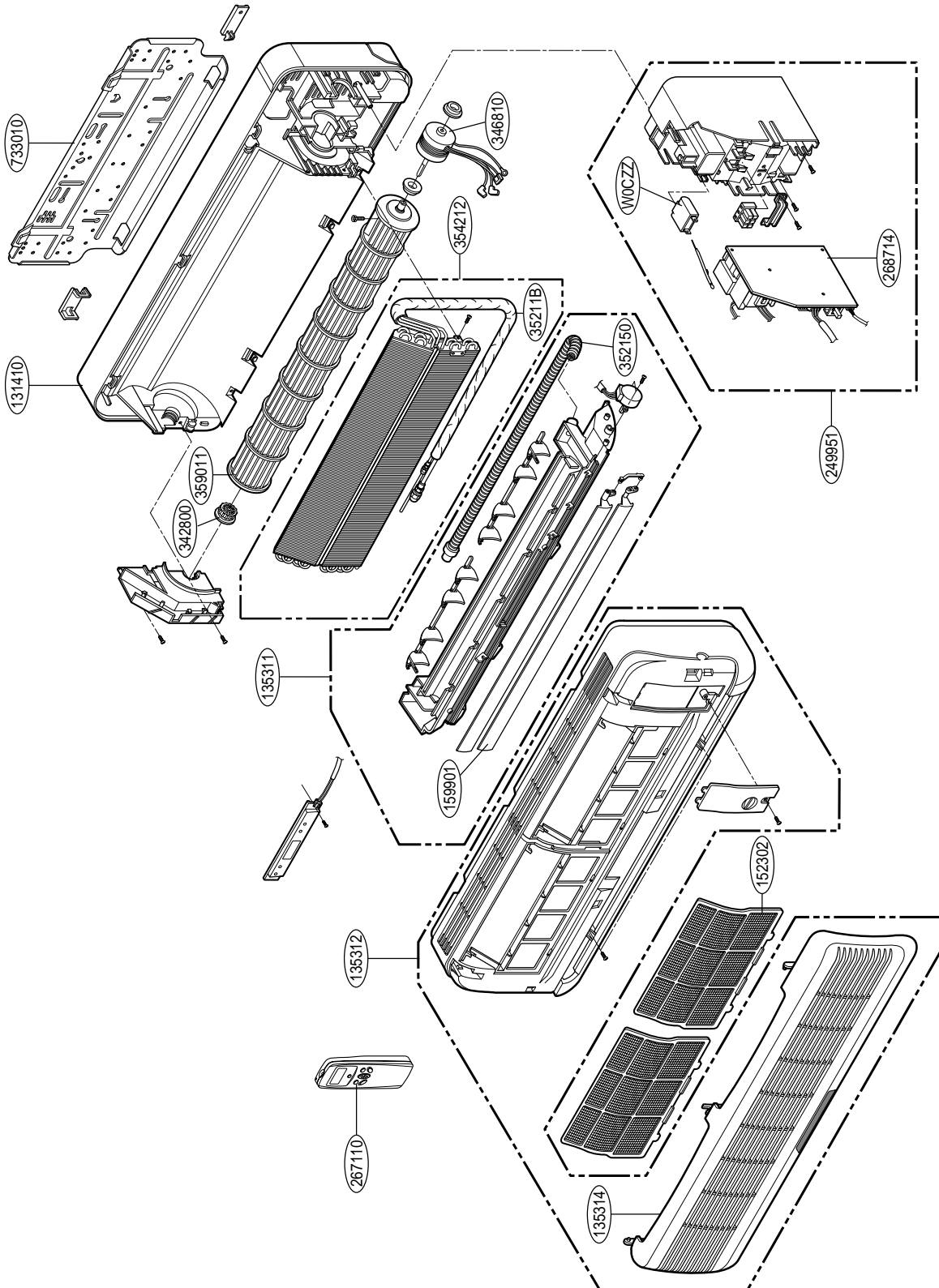

Parts List(Indoor Unit)

LOCATION No.	PART No.	DESCRIPTION	REMARKS	SUB PART No.
131410	3141A20003B	CHASSIS ASSY	R	
135311	3531A10023A	GRILLE ASSY, DISCHARGE(INDOOR)	R	
135312	3531A10052J	GRILLE ASSY, FRONT(INDOOR)	R	
135314	3531A10054E	GRILLE ASSY, INLET SUB	R	
146811	4681AR2727H	MOTOR ASSY, STEP	R	
152302	5230A20004A	FILTER(MECH), A/C	R	
159901	5990A30006B	VANE, HORIZONTAL	R	
159901	5990A30007B	VANE, HORIZONTAL	R	
249951	4995A20094S	CONTROL BOX ASSY, INDOOR	R	
263230	6323AQ2333A	THERMISTOR ASSY	R	
267110	6711A20016T	REMOTE CONTROLLER ASSY	R	
268712	6871A30009E	PWB(PCB) ASSY, DISPLAY	R	
268714	6871A20075Y	PWB(PCB) ASSY, MAIN	R	
342800	3H02821B	BEARING	R	
346810	4681A20003R	MOTOR ASSY, INDOOR	R	
35211B	2H02449J	TUBE ASSY,TUBING	R	
352150	5251AR2575A	HOSE ASSY, DRAIN	R	
354212	5421A20031S	EVAPORATOR ASSY, FINAL	R	
359011	5901AR6141B	FAN ASSY, CROSS FLOW	R	
733010	1H00843A	PLATE ASSY, INSTALL	R	
W0CZZ	3H01487A	CAPACITOR	R	

2. Outdoor Unit
• LM-2421C2L

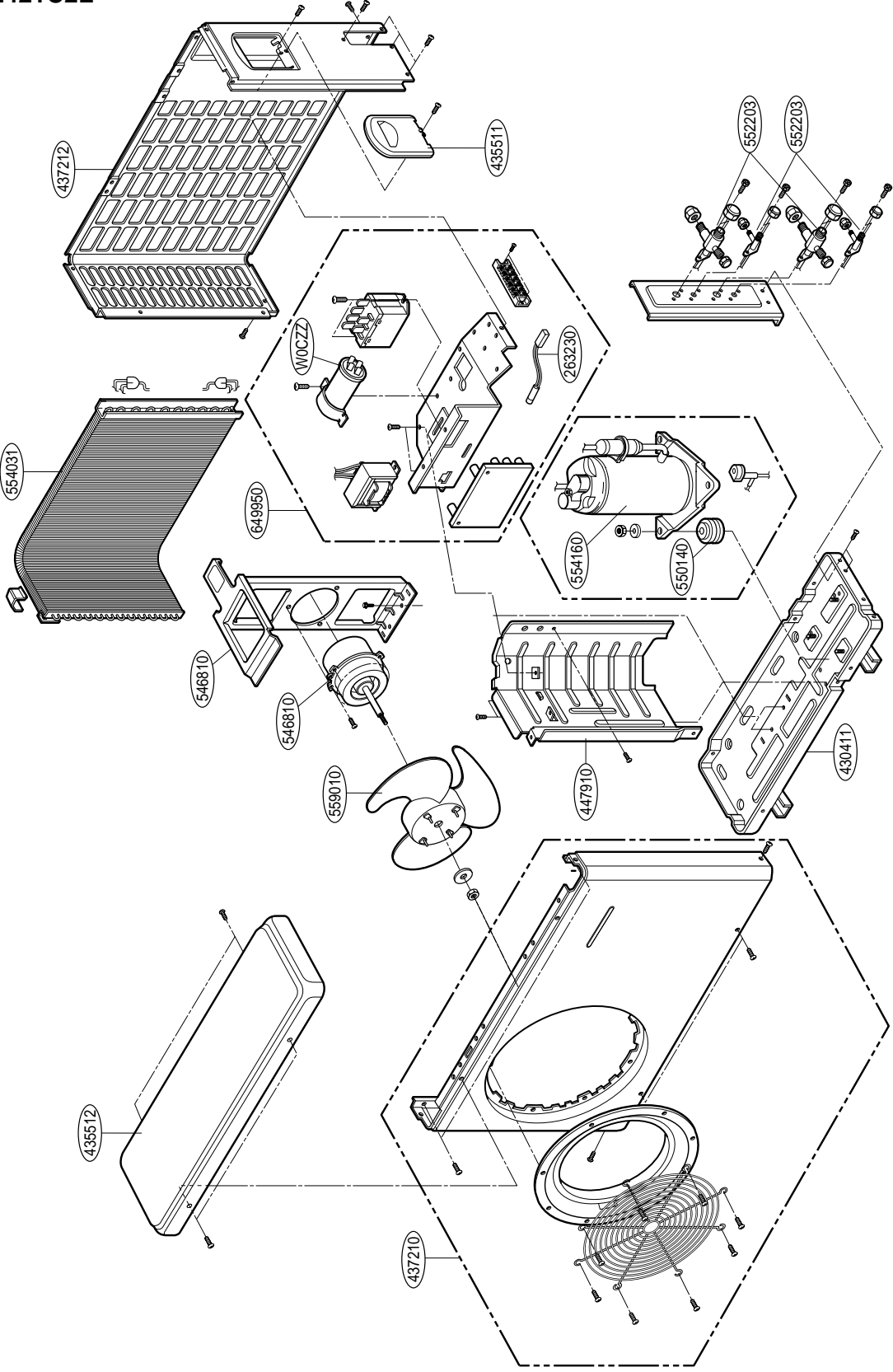

Parts List(LM-2421C2L)

LOCATION No.	PART No.	DESCRIPTION	REMARKS	SUB PART No.
263230	3Q35015E	THERMISTOR ASSY	R	
430411	3041A30003H	BASE ASSY, WELD(OUTDOOR)	R	
435511	3551A30028M	COVER ASSY, CONTROL(OUTDOOR)	R	
435512	3H03266K	COVER ASSY, TOP(OUTDOOR)	R	
437212	3720AP0003F	PANEL ASSY, REAR	R	
447910	4791A30004A	BARRIER ASSY, OUTDOOR	R	
546810	4681A20008D	MOTOR ASSY, A/C	R	
550140	4H00637A	ISOLATOR, COMP	R	
552101	5211A10088A	TUBE ASSY, CAPILLARY	R	
552203	2H01890D	VALVE, SERVICE	R	
552203	2H02479D	VALVE, SERVICE	R	
554031	5403A20022D	CONDENSER ASSY, BENT	R	
554160	5416AR1581B	COMPRESSOR	R	
559010	1A00195B	FAN ASSY, PROPELLER	R	
649950	4995A20044J	CONTROL BOX ASSY, OUTDOOR	R	
W0CZZ	6120AR2194D	CAPACITOR	R	

• LM-3022C3L

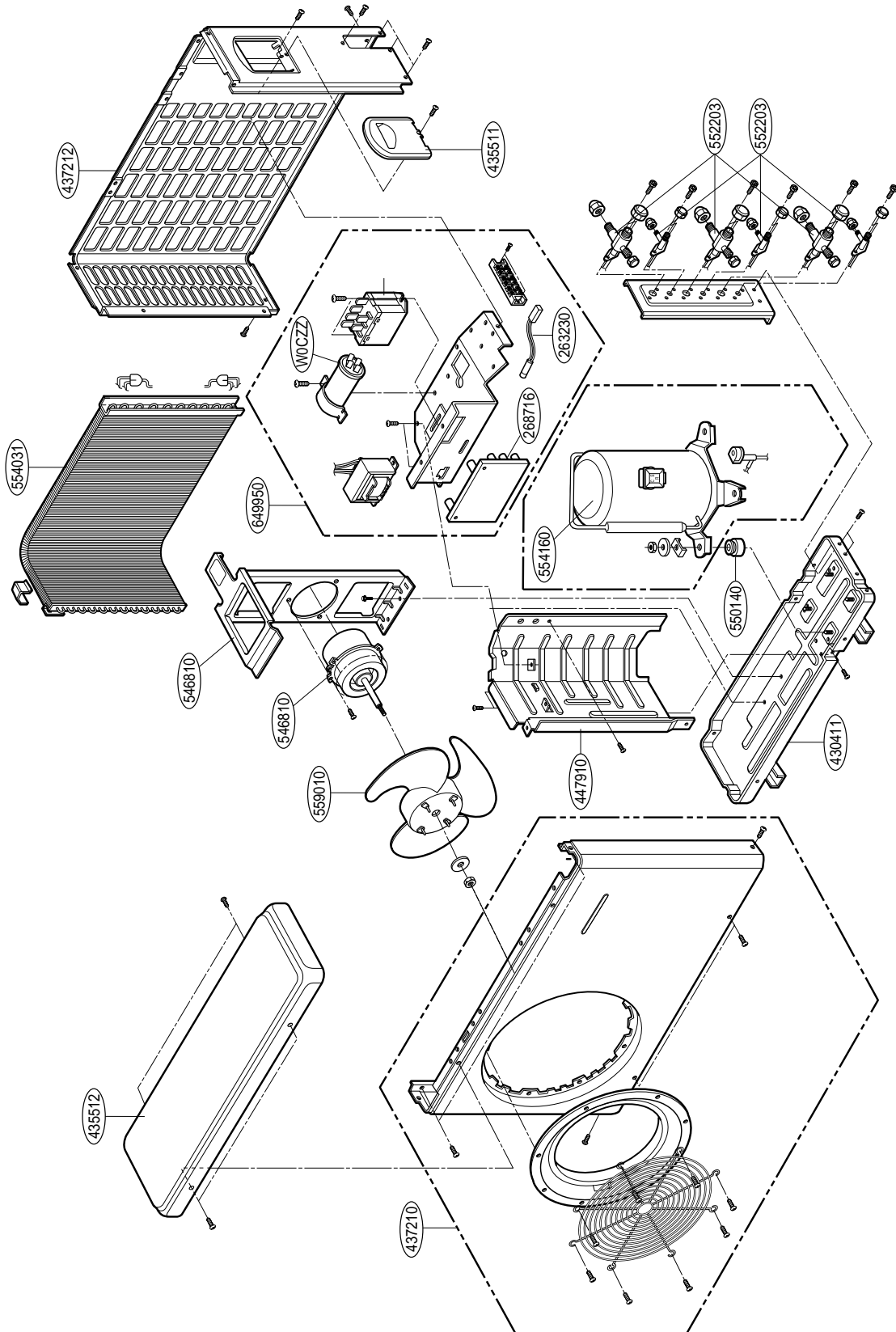

Parts List(LM-3022C3L)

LOCATION No.	PART No.	DESCRIPTION	REMARKS	SUB PART No.
263230	3Q35015E	THERMISTOR ASSY	R	
268716	6871A20031R	PWB(PCB) ASSY, MAIN(OUTDOOR)	R	
430411	3041A30003K	BASE ASSY, WELD(OUTDOOR)	R	
435511	3551AP7042V	COVER ASSY, CONTROL(OUTDOOR)	R	
435512	3H03266K	COVER ASSY, TOP(OUTDOOR)	R	
437212	3720AP0003F	PANEL ASSY, REAR	R	
447910	4791A30004A	BARRIER ASSY, OUTDOOR	R	
546810	4681A20008D	MOTOR ASSY, A/C	R	
546810	4961A20002C	MOUNT ASSY, MOTOR(OUTDOOR)	R	
552203	2H01890F	VALVE, SERVICE	R	
552203	2H02479L	VALVE, SERVICE	R	
554031	5403A20022B	CONDENSER ASSY, BENT	R	
554160	5417A10001C	COMPRESSOR ASSY, FINAL	R	
559010	1A00195B	FAN ASSY, PROPELLER	R	
649950	4995A20044E	CONTROL BOX ASSY, OUTDOOR	R	
W0CZZ	6120AR2194K	CAPACITOR	R	

