

installation operation and service instructions

HP14 Series Units

HEAT PUMP UNIT
502,383M
8/89
Supersedes 502,124M

RETAIN THESE INSTRUCTIONS FOR FUTURE REFERENCE

TABLE OF CONTENTS

| | |
|--|--------|
| UNIT DIMENSIONS – START-UP AND PERFORMANCE CHECK LIST..... | Page 1 |
| REQUIREMENTS – APPLICATION – INSTALLATION..... | Page 2 |
| PROCESSING – START-UP – OPERATION – MAINTENANCE | Page 3 |
| SYSTEM CONTROLS | Page 5 |
| MAINTENANCE..... | Page 7 |
| FIELD WIRING DIAGRAM..... | Page 8 |

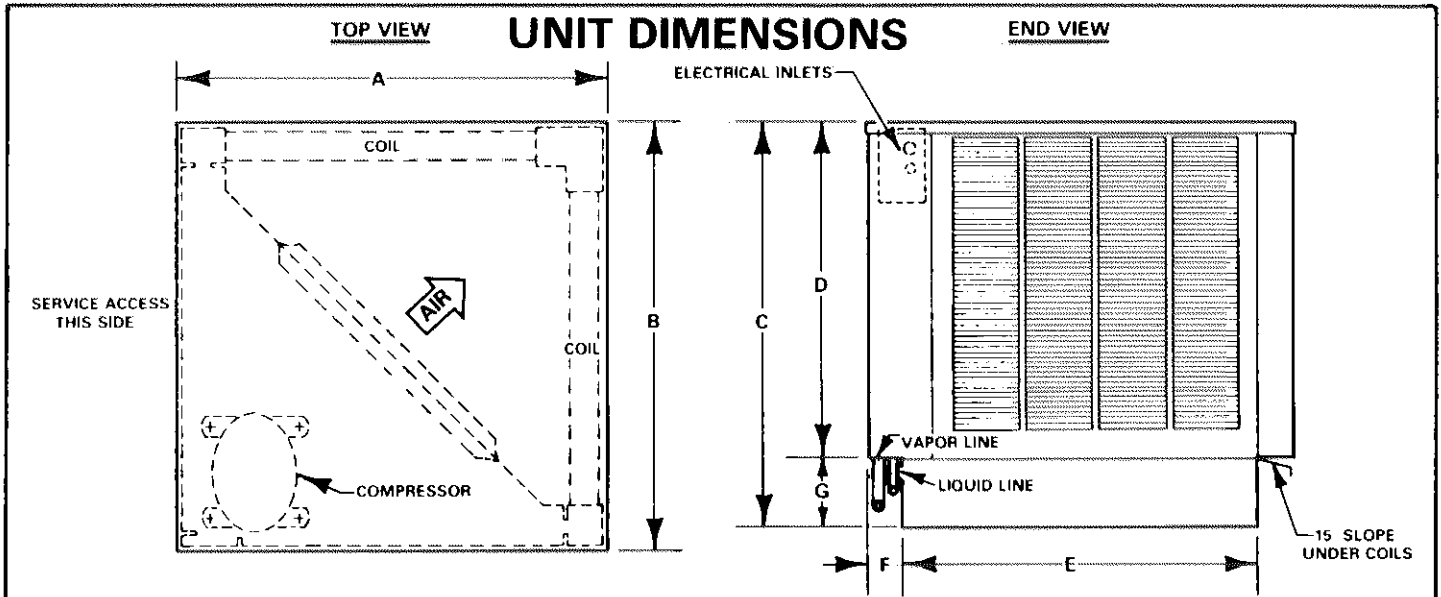

HP14

| MODEL NO. | A | | B | | C | | D | | E | | F | | G | |
|---------------|--------|------|--------|------|-----|-----|--------|-----|--------|-----|-------|----|-------|-----|
| | IN. | MM | IN. | MM | IN. | MM | IN. | MM | IN. | MM | IN. | MM | IN. | MM |
| HP14-260/410V | 36-1/8 | 918 | 36-1/8 | 918 | 33 | 838 | 28-1/4 | 718 | 29-1/2 | 749 | 3-1/4 | 83 | 4-3/4 | 121 |
| HP14-310/510V | 40 | 1016 | 40 | 1016 | 35 | 889 | 30-1/4 | 768 | 33-3/8 | 848 | 3-1/4 | 83 | 4-3/4 | 121 |
| HP14-410/650V | | | | | | | | | | | | | | |

START-UP AND PERFORMANCE CHECK LIST

Job Name _____ Job No. _____ Date _____
 Job Location _____ City _____ State _____
 Installer _____ City _____ State _____
 Unit Model No. _____ Serial No. _____ Serviceman _____

ELECTRICAL

Nameplate Voltage _____
 Minimum Circuit Ampacity _____
 Maximum Fuse Size _____
 Electrical Connections Tight?
 Supply Voltage (Unit Off) _____

* Voltage with Compressor Operating _____
 Amps:
 Supply _____ Outdoor Fan _____
 Compressor _____
 Indoor Filter Clean? Indoor Blower RPM _____
 S.P. Drop Over Indoor Coil (Dry) _____
 Outdoor Coil Entering Air Temperature _____
 Discharge Pressure _____ Suction Pressure _____

HEAT PUMP SECTION

Refrigerant Lines:
 Leak Checked Properly Insulated
 Service Valves Backseated
 Outdoor Fan Checked

THERMOSTAT

Calibrated Level

*Use 208V tap on HP14 transformer primary if measured voltage is 208V or less.

REQUIREMENTS — APPLICATION — INSTALLATION

I - SHIPPING AND PACKING LIST

Package 1 of 1 contains:

- 1 - Assembled unit
- 1 - Compressor warning sticker

II - GENERAL

These instructions are intended as a general guide and do not supersede local codes in any way. Authorities having jurisdiction should be consulted before installation.

III - SHIPPING DAMAGE

Check unit for shipping damage. The receiving party should contact last carrier immediately if any damage is found.

IV - APPLICATION

HP14 heat pump units are approved and warranted only for installation with specially matched indoor coils, L10 line sets, and refrigerant control devices as designated by Lennox. Refer to the Lennox Engineering Handbook for approved systems.

V - CLEARANCES

Refer to Figure 1 and provide service and air flow clearances as follows:

- 1 - Coil inlet - A minimum of 18 inches (457 mm) should be provided between the coil inlet and any building surfaces, fences or other vertical obstructions.
- 2 - Coil outlet - Provide at least 4 feet (1.22 m) between the coil outlet and any building surfaces, fences or other vertical obstructions.
- 3 - Service access - Allow a minimum of 3 feet (0.91 m) clearance on the service access side of unit.

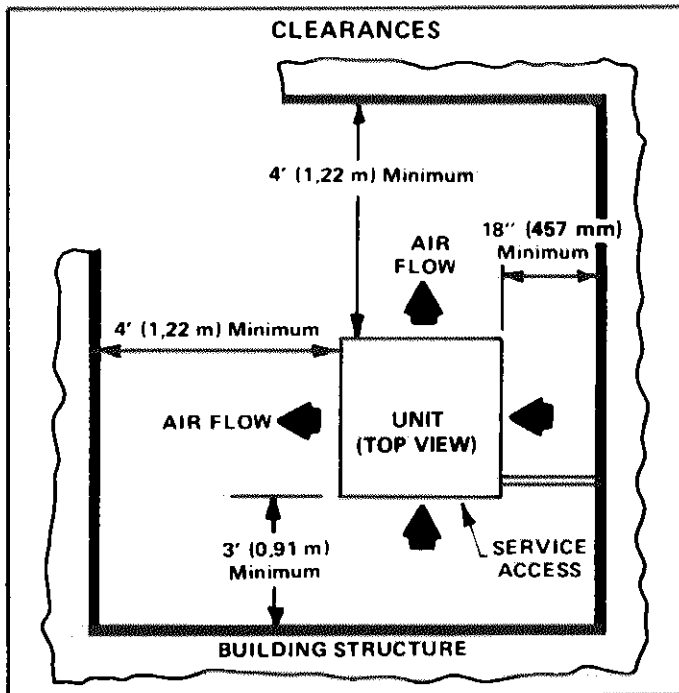

FIGURE 1

VI - SETTING THE UNIT

Heat pump units operate under a wide range of weather conditions, therefore, several factors must be considered when positioning the outdoor unit.

- 1 - A sound absorbing material, such as Isomode, should be used under a unit if it will be installed in a location or position that will transmit sound or vibration to the living area or adjacent buildings.
- 2 - Mount unit high enough above ground or roof to allow adequate drainage of defrost water and prevent ice build-up.

- 3 - In heavy snow areas do not locate unit where drifting will occur. The unit base should be elevated above the depth of average snows.

NOTE - Elevation of the unit may be accomplished by constructing a frame using suitable materials. If a support frame is constructed, it must not block drain holes in unit base.

- 4 - When installed in areas where low ambient temperature exist, unit should be located so winter prevailing winds do not blow directly into outdoor coils. See Figure 3.

- 5 - Locate unit away from overhanging roof lines which would allow water or ice to drop on, or in front of coils or inlet louvers.

A - Slab Mounting

When installing unit at grade level, top of slab should be high enough above grade so that water from higher ground will not collect around unit. Slab should have a slope tolerance away from building of 2 degrees or 2 inches per 5 feet (51 mm per 5 meters). This will prevent ice build-up under unit during a defrost cycle.

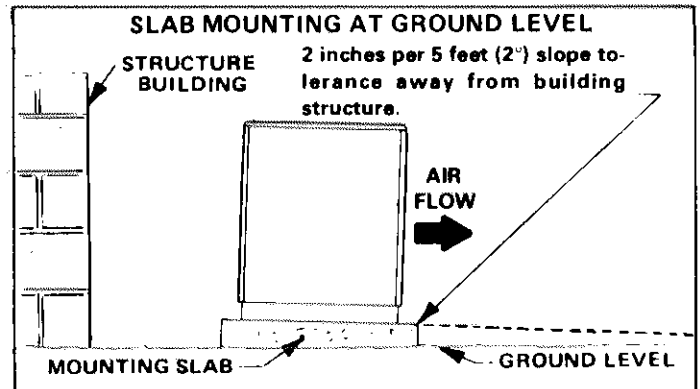

FIGURE 2

B - Roof Mounting

If unit coil cannot be mounted away from prevailing winter winds, a wind barrier should be constructed. Size barrier at least the same height and width as outdoor unit. Mount barrier 24 inches (610 mm) from inlet sides of unit in the direction of prevailing winds.

Refer to Figure 3.

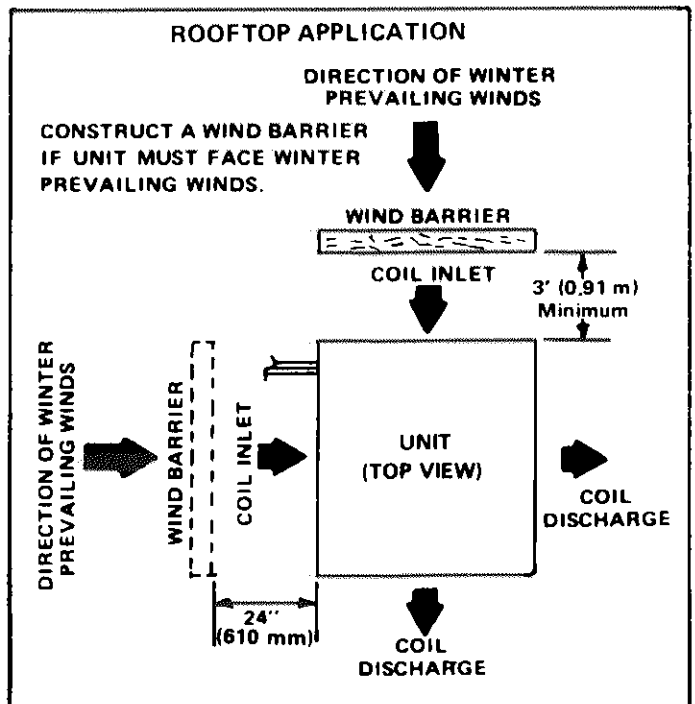

FIGURE 3

VII - ELECTRICAL

Wiring must conform to the National Electric Code (NEC) and local codes. Application diagrams are included at the back of this instruction and in indoor unit instructions.

Refer to unit rating plate for minimum circuit ampacity and maximum fuse size.

- 1 - Provide line voltage power supply to unit from a properly sized disconnect switch.
- 2 - Install room thermostat in the conditioned area. Locate where it will not be affected by sunlight, drafts or vibration. Do not install on an outside wall. A position approximately 5 feet (1.5 m) from the floor and near the center of the conditioned area is most desirable.

- 3 - Provide low voltage wiring from HP14 to indoor unit and from thermostat to indoor unit as indicated on the field diagram in this instruction.
- 4 - Ground unit either through supply wiring or with an earth ground.
- 5 - Mount compressor warning sticker on unit disconnect box.
- 6 - Check for proper tap selection on HP14 control transformer.

VIII - REFRIGERANT PIPING

Field refrigerant piping consists of liquid and vapor lines from the unit to the indoor coil. Use applicable Lennox L10 series line sets as shown in Table 1. These line sets may be shortened in the field when necessary, but should be limited to a maximum of 50 feet.

TABLE 1

| Outdoor Unit Model | L10 LINE SETS | | | | | | | | | | |
|--------------------|------------------|--------|------|--------------------------|------|---------------------|------|-------------------------|------|---------------------|------|
| | Line Set Numbers | Length | | Suction Line Connections | | | | Liquid Line Connections | | | |
| | | | | Outdoor Unit | | Indoor Coil (Flare) | | Outdoor Unit | | Indoor Coil (Flare) | |
| | | ft. | m | in. | mm | in. | mm | in. | mm | in. | mm |
| HP14-260/410V | L10-41-20 | 20 | 6.1 | 3/4 | 19.1 | 3/4 | 19.1 | 3/8 | 9.5 | 3/8 | 9.5 |
| | L10-41-30 | 30 | 9.1 | | | | | | | | |
| | L10-41-40 | 40 | 12.2 | | | | | | | | |
| | L10-41-50 | 50 | 15.2 | | | | | | | | |
| HP14-310/510V | L10-65-30 | 30 | 9.1 | 7/8 | 22.2 | 3/4* | 19.1 | 3/8 | 9.5 | 3/8 | 9.5 |
| | L10-65-40 | 40 | 12.2 | | | | | | | | |
| HP14-410/650V | FIELD FABRICATED | 0 | 0 | 1-1/8 | 28.6 | 1-1/8 | 28.6 | 1/2 | 12.7 | 1/2 | 12.7 |

*To obtain maximum efficiency, remove the 3/4 in. (19 mm) reduction from the L10-65 series line sets and the corresponding flare fitting from the indoor coil should it have one. Then, make a sweat connection using a 7/8" X 1-1/8" (22 X 29 mm) reducer coupling if needed.

PROCESSING – START-UP – OPERATION – MAINTENANCE

I - PROCESSING PROCEDURE

The unit is factory charged with the amount of R-22 refrigerant indicated on the unit rating plate. This charge is based on a matching indoor coil and outdoor coil with a 25 ft. (7.6 m) line set. For varying lengths of line set, refer to Table 2 for refrigerant charge adjustment. A blank space is provided on the unit rating plate to list actual field charge. All units are factory leak tested and evacuated, making it necessary to keep unit free of dirt, moisture and air.

WARNING - Do not open (back-seat) valves on unit until leak testing and evacuating of line sets have been completed.

TABLE 2

| Line Set Diameter | | *Ounce per ft. adjustment from 25 ft. (7620 mm) line set |
|-------------------|---------------|--|
| Suction | Liquid | |
| 5/8" (16 mm) | 3/8" (9.5 mm) | 1 ounce (28 grams) |
| 3/4" (19 mm) | 3/8" (9.5 mm) | 1 ounce (28 grams) |
| 7/8" (22 mm) | 3/8" (9.5 mm) | 1 ounce (28 grams) |
| 1-1/8" (29 mm) | 1/2" (13 mm) | 1-3/4 ounces (50 grams) |

*If line set length is greater than 25 ft. (7620 mm), add this amount. If line set length is less than 25 ft. (7620 mm), subtract this amount.

A - Attaching Gauge Manifold

- 1 - Leak Testing or Evacuating - Connect high pressure side of gauge manifold to gauge port on liquid line service valve. Con-

nect suction side of gauge manifold to gauge port on vapor line service valve. Refer to dotted lines in Figure 4.

- 2 - Checking Charge or Charging-Connect high pressure side of gauge manifold to discharge line gauge port. Connect suction side of gauge manifold to suction line gauge port. Refer to Figure 4.

B - Leak Testing Installed Line Set

- 1 - Attach gauge manifold as explained in Step 1 of section A, "Attaching Gauge Manifold." Connect a drum of dry nitrogen to center port of gauge manifold.

CAUTION - When using dry nitrogen, a pressure reducing regulator must be used to prevent excessive pressure in gauge manifold, connecting hoses and within the system. Regulator setting must not exceed 150 psig (1034 kPa).

- 2 - Open dry nitrogen valve and gauge manifold high pressure valve and pressurize line set and indoor coil of system to 150 psig (1034 kPa).
- 3 - Close gauge manifold high pressure valve and check all lines and connections for leaks.

NOTE - If electronic leak detector is used, add a trace of refrigerant to system for detection by the leak detector prior to charging with dry nitrogen.

- 4 - Release nitrogen pressure, correct any leaks in the system and recheck.

HP14 COOLING CYCLE (SHOWING GAUGE MANIFOLD CONNECTIONS)

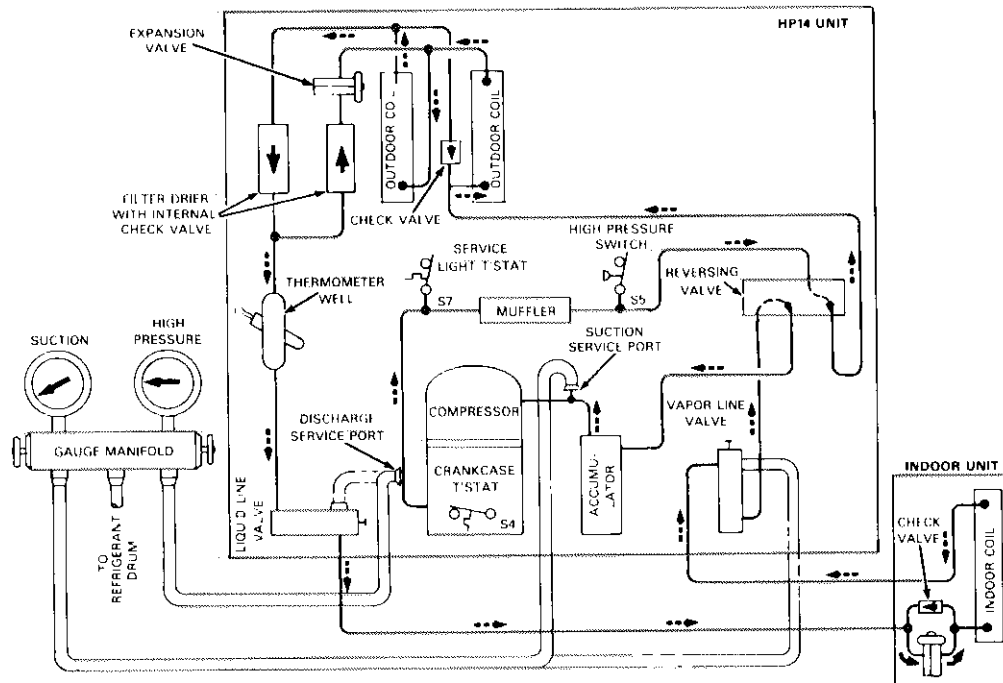

NOTE - Arrows indicate direction of refrigerant flow in cooling mode.

FIGURE 4

C - Evacuating System

When required, evacuate system as follows:

- 1 - Attach gauge manifold as explained in Step 1 of Section A, "Attaching Gauge Manifold." Connect vacuum pump (with vacuum gauge) to center port of gauge manifold. With both manifold service valves open, start pump and evacuate indoor coil and refrigerant lines.

NOTE - A temperature vacuum gauge, mercury vacuum (U tube), or thermocouple gauge should be used. The usual Bourdon tube gauges are not accurate enough in the vacuum range.

- 2 - Evacuate the system to 29 in. (737 mm) vacuum. During the early stages of evacuation, it is desirable to stop the vacuum pump at least once to determine if there is a rapid loss of vacuum. A rapid loss of vacuum would indicate a leak in the system and a repeat of Section B, "Leak Testing," would be necessary.
- 3 - After system has been evacuated to 29 in. (737 mm), close gauge manifold valves to center port, stop vacuum pump, and disconnect from gauge manifold. Attach an upright nitrogen drum to center port of gauge manifold and open drum valve slightly to purge line at manifold. Break vacuum in system with nitrogen pressure by opening manifold high pressure valve. Close manifold high pressure valve to center port.
- 4 - Close nitrogen drum valve and disconnect from gauge manifold center port. Release nitrogen pressure from system.
- 5 - Reconnect vacuum pump to gauge manifold center port. Evacuate system through manifold service valves until vacuum in system does not rise above 29.7 in. (754 mm) mercury (5 mm absolute pressure) within a 20-minute period after stopping vacuum pump.
- 6 - After evacuation is completed, close manifold service valves, disconnect vacuum pump from gauge manifold center port, and connect refrigerant drum. Pressurize system slightly with refrigerant to break vacuum.

D - Start-Up Procedure

- 1 - Rotate fan to check for frozen bearings or any binding.

- 2 - Inspect all wiring (both factory and field-installed) for loose connections.
- 3 - Open liquid and vapor line service valves to release refrigerant charge (confined in heat pump unit) into system.
- 4 - Check voltage supply at disconnect switch; voltage must be within the range listed on unit nameplate. If voltage is not in this range, do not start the equipment until power company has been consulted and the voltage condition corrected.
- 5 - Set thermostat for a demand. Turn on power to indoor coil blower and close heat pump disconnect switch. Push the override button on the two speed controller to bypass the time-delay to start unit.
- 6 - Recheck unit voltage with unit running. Power must be within range shown on unit nameplate. Check amperage draw of unit. Refer to unit nameplate for correct running amps.

E - Charging/Checking Charge

If the system is completely void of refrigerant, the recommended and most accurate method of charging is to weigh the refrigerant into the unit according to the total amount shown on the unit nameplate. Refer to the "Lennox Service Manual" for procedure. If weighing facilities are not available or if unit is just low on charge, use the following procedure:

- 1 - Connect gauge manifold as shown on Page 4 "Gauge Manifold Connections." Connect an upright R-22 drum to center port of gauge manifold.
- 2 - Set room thermostat to 74°F (23°C) in EMERGENCY HEAT (if available) or HEATING position and allow unit to run until heating demand is satisfied. This will create the necessary load for proper charging of system in cooling. Change thermostat setting to 68°F (20°C) in COOLING position.

- 3 - Follow instructions given on unit access panel for proper system charging.

NOTE - When checking or adjusting charge, compressor should always be on high speed. For cooling mode, set the room thermostat at the lowest setting. For heating mode, place a jumper across speed control thermostat (S6) in outdoor unit and then reset the room thermostat to "OFF" and back to "HEAT."

NOTE - The addition of 2 lbs. of charge should cause a change in stable operating pressures.

When system is operating properly, make sure all service valves are open (back-seated) and disconnect gauge manifold. Replace all gauge port caps and tighten. Set thermostat at desired setting.

II - COMPRESSOR OIL CHARGE

Refer to "Lennox Cooling Service Handbook" for correct procedure to check and add compressor oil.

III - LENNOX TWO SPEED CONTROLLER

The controller performs compressor speed changes on demand from the indoor thermostat. It also provides the following functions to protect unit:

- 1 - The controller provides a one minute delay between speed changes. This delay cannot be bypassed.
- 2 - The controller prevents compressor short cycling with a five minute timed-off delay.
- 3 - The controller stops compressor operation when motor winding overheats. Motor operation is blocked for a minimum of five minutes or until motor winding cools to within a specified temperature range.
- 4 - The controller locks out motor operation for five minutes when a safety device (e.g. high pressure switch) terminates motor operation. Motor operation is prohibited for five minutes, even if the safety device is reset within that five minutes.
- 5 - The controller locks out motor operation if overheating or compressor safety devices interrupt compressor operation 3 times during one thermostat demand period. Motor operation is locked out until thermostat demand is removed or power supply to controller is terminated.
- 6 - The controller has a manual override button that bypasses the five minute timed-off delay for servicing unit. This override button does not bypass the one minute delay between speed changes.

Refer to section XIV-Maintenance for Lennox two speed controller checkout procedure.

IV - HIGH PRESSURE SWITCH

All units are equipped with a high pressure switch (manual reset type) mounted on the compressor discharge line. This switch has a "cut-out" point of 410 psig (2827 kPa) and must be manually reset when discharge pressure drops below 180 psig (1241 kPa).

V - CRANKCASE TEMPERATURE LIMIT SWITCH

The units are equipped with a crankcase temperature limit switch which is mounted to the outside bottom of the compressor shell by means of a strap and fasteners. It prevents the compressor from operating at an exceedingly high oil temperature by opening the control circuit at 220°F (104.4°C). It automatically resets at 150°F (65.6°C).

VI - DEFROST TIMER

This control asks for a defrost every 90 minutes. If the temperature is below 35° F (2° C) and the defrost pressure switch senses a particular pressure differential, the unit will defrost. The defrost timer will not allow a defrost to last more than 10 minutes. The defrost timer can be field adjusted from a 90-minute to a 30-minute defrost interval if warranted by climatic conditions. See figure 5 for sequence of operations and section IX for timer conversion.

VII - DEFROST THERMOSTAT

A defrost thermostat is mounted on the liquid line between a drier and the distributor. The thermostat opens at 60° F ± 5° and closes at 35° F ± 4° making defrost available.

VIII - DEFROST PRESSURE SWITCH

A pressure sensor mounted on the division panel between the outdoor coil and the orifice panel senses the build-up of static pressure caused by coil icing across the outdoor coil. Every 90 minutes, if the control diaphragm senses a particular pressure differential, and the defrost thermostat is closed, a defrost cycle is initiated. Defrost cycle is terminated by the defrost thermostat or the defrost timer. If the coil does not rise to termination temperature within the time override period (approximately 10 minutes), the defrost cycle is terminated by the defrost timer. See figure 5 for normal and override operation sequences of the defrost timer.

NOTE - Termination of the defrost cycle, whether by rising temperature or by defrost timer override, begins another 30 or 90-minute period before the system checks for defrost again.

IMPORTANT - It is important that the placement and cleanliness of the defrost switches be maintained for proper unit operation. Inspect both sides of the outdoor coil periodically and remove any grass, leaves, or other obstructions.

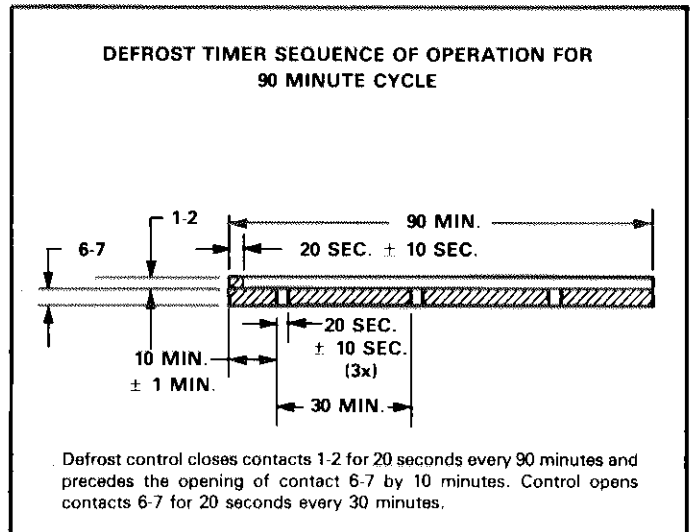

FIGURE 5

IX - TIMER CONVERSION FROM 90-MINUTE TO 30-MINUTE DEFROST INTERVAL

- 1 - Turn off power to unit.
- 2 - Disconnect wires to timer and remove timer from unit.
- 3 - Remove mounting screws and timer cover as shown in figure 6.

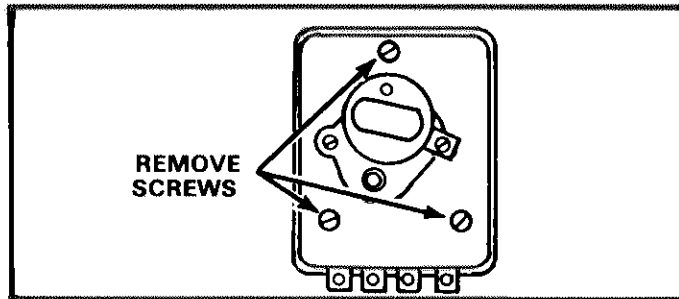

FIGURE 6

- 4 - Loosen allen screw and remove both cams as shown in figure 7.
- 5 - Install 30 minute cam only (cam with allen screw).
- 6 - Align the allen screw on the 30 minute cam with the 45° edge of the fixed cam as shown in figure 8 and tighten allen screw.

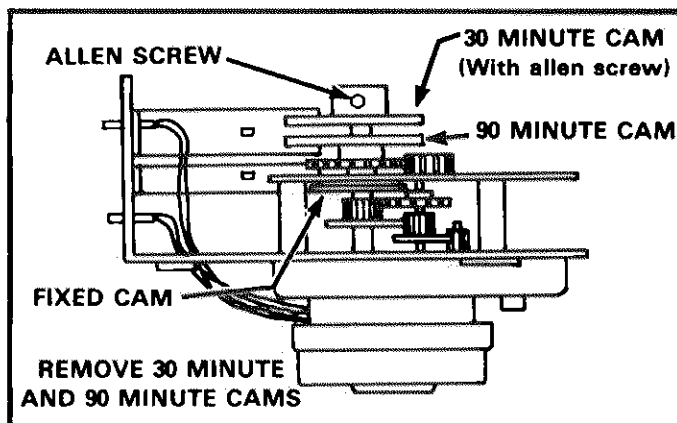

FIGURE 7

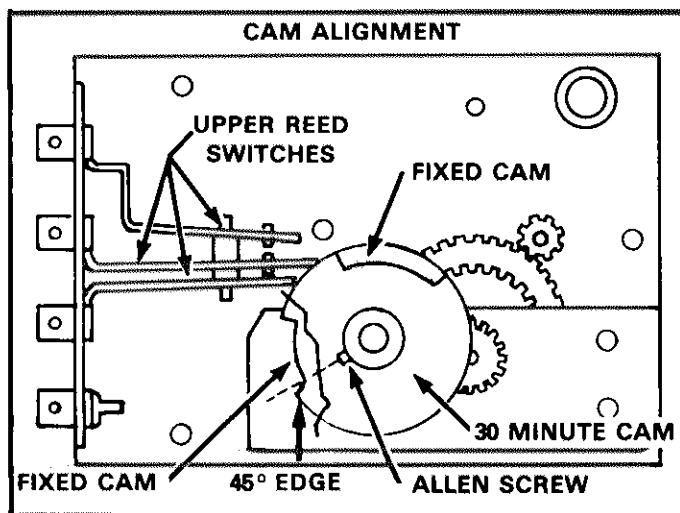

FIGURE 8

- 7 - Install timer cover and secure with mounting screws.
- 8 - Install timer in unit and connect wires to timer terminals. Refer to unit wiring diagram on the outdoor unit for proper wiring connections.
- 9 - Restore power to unit.
- 10 - Unit will follow the same sequence of operation shown in figure 5 except defrost interval will be every 30 minutes.

X - THERMOSTAT OPERATION

Heat pump thermostat used (ordered separately) incorporates isolating contacts and an emergency heat function which includes an orange indicating light. The thermostat displays additional indicator lights and uses an ambient compensating thermistor. Each feature is explained below.

1 - Isolating Contacts

The thermostat (ordered separately) is used in dual transformer control circuit systems. During use of the emergency heat function, the outdoor unit will be isolated from the control circuit power while the indoor continues to operate.

2 - Emergency Heat (Orange Light)

An emergency heat function is designed into the thermostat. This feature is applicable to systems using auxiliary electric heat staged by outdoor thermostats. When the thermostat is placed in the emergency heat position, the outdoor unit control circuit is isolated from power and field provided relays bypass the outdoor thermostats. An orange indicating light simultaneously comes on to remind the homeowner that he is operating in the emergency heat mode. Emergency heat is usually used during a heat pump shutdown, but it should also be used following a power outage if power has been off over an hour and the outdoor temperature is below 50° F (10° C). System should operate at least 6 hours in emergency heat mode to allow the crankcase heater sufficient time to prevent compressor slugging.

3 - Service Light (Red)

The service light is wired in series with the second stage heat bulb of the room thermostat and a thermal sensor that is strapped to the compressor discharge line. The sensor monitors discharge temperature and closes on a temperature fall which indicates the compressor is not operating properly and that service is required. A red light represents a heat pump malfunction during the heating mode. It warns the homeowner that the electric elements are providing all the heat.

If the red light comes on, place the room thermostat into emergency heat to bypass any outdoor thermostat(s) making all the auxiliary heat available. Under these conditions, the orange light will be energized continuously and the red light will cycle with the indoor unit.

- 4 - When system is operating in low speed the green light comes on.
- 5 - When system is operating in high speed the amber light comes on.
- 6 - The ambient compensating thermistor (located in the outdoor unit) cuts down thermostat droop to improve the operating characteristics of the heat pump system.

XI-SPEED CONTROL THERMOSTAT

The speed control thermostat located in the outdoor unit regulates compressor speed during the heating mode only. A 10° F differential prevents frequent compressor speed changes. When outdoor temperature rises to 65° F during heating cycle, compressor runs on low speed. When outdoor temperature drops to 55° F during heating cycle, compressor runs on high speed.

XII - CRANKCASE HEATERS

All units are provided with crankcase heaters (oil rectifiers). This heater must always be energized to prevent compressor damage as a result of slugging. A warning sticker (provided with instructions) should be applied to the main disconnect switch at the time of installation.

XIII - FILTER DRIER

The filter-drier system consists of two filter-driers mounted in a parallel flow arrangement in the liquid line of the system. One drier is for the cooling cycle, the other is for the heating cycle. Each drier is equipped with an internal check valve for correct refrigerant flow. Refer to figure 4. If replacement is necessary, order another of like design and capacity.

XIV - MAINTENANCE

At the beginning of each heating or cooling season, the system should be cleaned as follows:

A - Heat Pump Unit

- 1 - Clean and inspect both sides of outdoor coil. Coil may be flushed with water hose if necessary.
- 2 - Clean and inspect defrost pressure sensors.
- 3 - Oil outdoor fan motor: Always relubricate motor according to manufacturer's lubrication instructions on each motor. If no instructions are provided, use the following as a guide:
 - a - Motors with Oiling Ports - Prelubricated for an extended period of operation. For extended bearing life, relubricate with a few drops of SAE No. 10, non-detergent oil once every two years.
 - b - Motors without Oiling Ports - Prelubricated and sealed. No further lubrication required.
- 4 - Visually inspect all connecting lines, joints and coils for evidence of oil leaks.
- 5 - Check all wiring for loose connections.
- 6 - Check for correct voltage at unit (unit operating).
- 7 - Check amp-draw on heat pump fan motor.

Unit nameplate _____ Actual _____

- 8 - Inspect drain holes in coil compartment base and clean if necessary.
NOTE - If insufficient heating or cooling occurs, unit should be gauged and refrigerant charge checked.

B - Indoor Coil

- 1 - Clean coil if necessary.
- 2 - Check connecting lines, joints and coil for evidence of oil leaks.
- 3 - Check condensate line and clean if necessary.

C - Indoor Unit

- 1 - Clean or change filters.
- 2 - Lubricate blower motor.
Always relubricate motor according to manufacturer's lubrication instructions on each motor. If no instructions are provided, use the following as a guide:
 - a - Motors without Oiling Ports - Prelubricated and sealed. No further lubrication required.
 - b - Direct Drive Motors with Oiling Ports - Prelubricated for an extended period of operation. For extended bearing life, relubricate with a few drops of SAE No. 10, non-detergent oil once every two years. It may be necessary to remove blower assembly for access to oiling ports.
- 3 - Adjust blower speed for cooling. The pressure drop over the coil should be checked to determine the correct blower CFM. Refer to the "Lennox Cooling Service Handbook" for pressure drop tables and procedures.
- 4 - Check all wiring for loose connections
- 5 - Check for correct voltage at unit.
- 6 - Check amp-draw on blower motor.

Motor nameplate _____ Actual _____

D - Lennox Two Speed Controller (TSC-1) Check Procedure

- 1 - Manually reset high pressure switch "S5" in the outdoor unit.
- 2 - Turn thermostat to "OFF" position.
- 3 - *Cooling Mode* — Set thermostat to lowest temperature setting. Turn indoor thermostat to "ON" position.
Heating Mode — Place jumper across speed control thermostat "S6" in outdoor unit, and set indoor thermostat to highest setting. Turn indoor thermostat to "ON" position.
- 4 - Wait at least 10 seconds to allow controller to power up. Push the override button on the controller to bypass the five minute timed-off delay.
- 5 - Allow one minute for unit to start.
- 6 - If unit does not start, check voltage across terminals "M" and "X" and "M2" and "X" of the heat pump's low voltage terminal strip. Voltage should be 24 VAC \pm 6. If voltage is not 24 VAC \pm 6, check indoor thermostat for malfunctions.
- 7 - Check contactors in heat pump unit. "K1" and "K2" should be energized for single phase units. Only "K2" should be energized for three phase units.
- 8 - *Cooling Mode Low Speed Check-Out* — Turn indoor thermostat OFF. Disconnect wire from terminal "M2" of the low voltage terminal strip. Turn indoor thermostat to "ON" position.
Heating Mode Low Speed Check-Out — Turn indoor thermostat OFF. Remove jumper from across the speed control thermostat "S6" and disconnect wires from one side of the speed control thermostat. Turn indoor thermostat to "ON" position.
- 9 - Wait at least 10 seconds for controller to power up. Push override button on the controller to bypass the five minute timed-off delay.
- 10 - Allow one minute for the unit to start.
- 11 - If unit does not start, check voltage across terminal "M" and "X" of the heat pump's low voltage terminal strip. Voltage should be 24 VAC \pm 6. If voltage is not 24 VAC \pm 6, check indoor thermostat for malfunctions.
- 12 - Check contactors in heat pump unit. "K2" should be energized for single phase units. "K1" should be energized for three phase units.
- 13 - Check the secondary output voltage of the transformer in the heat pump unit. Voltage should be 24 VAC \pm 6. If voltage is not 24 VAC \pm 6, check transformer.
- 14 - Turn OFF power to indoor and outdoor units. Disconnect jack plug from TSC-1 controller.
- 15 - Turn ON power to heat pump. Check voltage across terminals "2" and "7" of jack plug. Voltage should be 24 VAC \pm 6. If voltage is not 24 VAC \pm 6, check high pressure switch "S5" and crankcase heater switch.
- 16 - Turn OFF power to heat pump. Disconnect the two red wires from the two speed controller. Check resistance of the internal sensor. If resistance is within reset range specified on compressor nameplate, replace TSC-1 controller. If resistance is in the range of high limit trip, allow compressor sufficient time to cool down to the reset range. Reconnect red wires and jack plug. Repeat checkout procedure beginning with step 2.

ARROWS DENOTE WIRING
WHEN ELECTRIC HEAT IS USED

NOTE — SEE HP14 AND E16 UNIT WIRING DIAGRAMS
FOR POWER SUPPLY CONNECTIONS.
EMERGENCY HEAT RELAY FIELD PROVIDED
AND INSTALLED NEAR INDOOR UNIT, 24 VAC,
5VA MAX. NEC CLASS 2.
(USED ONLY IF OUTDOOR T'STAT (S3) IS USED)

