

HP29 SERIES UNITS

The HP29 is a residential split-system heat pump. Outdoor coil size, circuiting and air volume result in a minimum SEER rating of 10.0. **All HP29 units are designed for use with thermal expansion valves.**

Some HP29 units (-211 through -650, -018 and -024) utilize a reciprocating compressor. These models are furnished with crankcase heaters. The heater prevents liquid from accumulating in the compressor. All compressors are hermetically sealed for trouble-free operation and long service life. Reciprocating compressor components are spring-mounted within the sealed housing. A built-in limit protects the compressor from excessive current and temperatures. Other HP29 units (-030 through -060) utilize a scroll compressor. The scroll operates like a standard heatpump, but is unique in the way that it compresses refrigerant.

This manual is divided into sections which discuss major components, refrigerant system, charging procedures, maintenance, and operation sequence .

All specifications in this manual are subject to change.

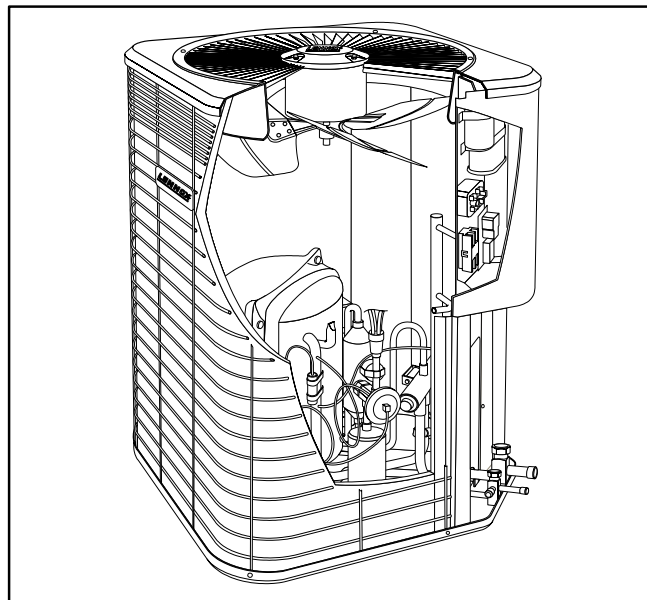

SPECIFICATIONS

Model No.			HP29-211	HP29-261	HP29-311
Outdoor Coil	Net face area - sq. ft. (m ²)	Outer coil	11.41 (1.06)	11.41 (1.06)	13.31 (1.24)
		Inner coil	----	----	----
	Tube diameter — in. (mm) & no. of rows	5/16 (7.9) — 1		5/16 (7.9) — 1	5/16 (7.9) — 1
Fins per inch (m)		22 (866)		22 (866)	22 (866)
Outdoor Coil Fan	Diameter — in. (mm) & no. of blades		18 (457) — 3	18 (457) — 3	18 (457) — 4
	Motor hp (W)		1/6 (124)	1/6 (124)	1/6 (124)
	Cfm (L/s)		2400 (1135)	2400 (1135)	2500 (1180)
	Rpm		1105	1105	1100
	Watts		180	180	200
*Refrigerant charge furnished (HCFC-22)			4 lbs. 5 oz. (1.96 kg)	4 lbs. 4 oz. (1.92 kg)	4 lbs. 15 oz. (2.24 kg)
Liquid line — in. (mm) o.d. connection (sweat)			**3/8 to 5/16 (8)	**3/8 to 5/16 (8)	**3/8 to 5/16 (8)
Vapor line — in. (mm) o.d. connection (sweat)			5/8 (15.9)	5/8 (15.9)	3/4 (19.1)
Shipping weight — lbs. (kg) 1 package			152 (69)	152 (69)	164 (74)

*Refrigerant charge sufficient for 20 ft. (6.1 m) length of refrigerant lines.
**5/16 to 3/8 reducer coupling supplied with unit.

SPECIFICATIONS

Model No.			HP29-411/HP29-41	HP29-461/HP29-463	HP29-511/HP29-513	HP29-651/HP29-653
Outdoor Coil	Net face area - sq. ft. (m ²)	Outer coil	15.21 (1.41)	15.21 (1.41)	15.21 (1.41)	15.21 (1.41)
		Inner coil	----	5.44 (0.51)	5.44 (0.51)	14.50 (13.5)
	Tube diameter — in. (mm) & no. of rows	5/16 (7.9) — 1		5/16 (7.9) — 1.37	5/16 (7.9) — 1.37	5/16 (7.9) — 2
Fins per inch (m)		22 (866)		22 (866)	22 (866)	22 (866)
Outdoor Coil Fan	Diameter — in. (mm) & no. of blades		18 (457) — 4	18 (457) — 4	18 (457) — 4	18 (457) — 4
	Motor hp (W)		1/6 (124)	1/6 (124)	1/3 (249)	1/3 (249)
	Cfm (L/s)		2520 (1190)	2500 (1180)	2950 (1390)	2930 (1385)
	Rpm		1100	1100	1100	1100
	Watts		200	200	310	310
*Refrigerant charge furnished (HCFC-22)			6 lbs. 3 oz. (2.81 kg)	7 lbs. 13 oz. (3.54 kg)	7 lbs. 1 oz. (3.20 kg)	9 lbs. 0 oz. (4.08 kg)
Liquid line — in. (mm) o.d. connection (sweat)			3/8 (9.5)	3/8 (9.5)	3/8 (9.5)	3/8 (9.5)
Vapor line — in. (mm) o.d. connection (sweat)			3/4 (19.1)	7/8 (22.2)	7/8 (22.2)	1-1/8 (28.6)
Shipping weight — lbs. (kg) 1 package			174 (79)	199 (90)	206 (93)	221 (100)

*Refrigerant charge sufficient for 20 ft. (6.1 m) length of refrigerant lines.

SPECIFICATIONS

Model No.			HP29-018	HP29-024	HP29-030	HP29-036-1ph	HP29-036-3ph
Outdoor Coil	Net face area sq. ft. (m ²)	Outer coil	11.41 (1.06)	11.41 (1.06)	15.21 (1.43)	15.21 (1.41)	15.21 (1.41)
		Inner coil	----	----	5.44 (.51)	14.50 (1.35)	5.44 (.51)
	Tube diam.-in. (mm) no. of rows	5/16 (7.9) — 1	5/16 (7.9) — 1	5/16 (7.9) — 1	5/16 (7.9) — 2	5/16 (7.9)-1.37	
	Fins per inch (m)	22 (866)	22 (866)	18 (709)	18 (709)	22 (866)	
Outdoor Coil Fan	Diameter-in. (mm) no. of blades		18 (457) — 3	18 (457) — 3	18 (457) — 4	18 (457) — 4	18 (457) - 4
	Motor hp (W)		1/6 (124)	1/6 (124)	1/6 (124)	1/6 (124)	1/6 (124)
	Cfm (L/s)		2400 (1135)	2400 (1135)	2550 (1203)	2530 (1193)	2500 (1180)
	Rpm		1105	1105	1115	1110	1100
	Watts		180	180	190	195	200
*Refrigerant charge furnished (HCFC-22)			4 lbs. 2 oz. (1.86 kg)	4 lbs. 1oz. (1.83 kg)	5 lbs.12 oz. (2.6 kg)	7 lbs.2 oz. (3.22kg)	6 lbs 0 Oz. (2.72kg)
Liquid line — in. (mm) o.d. conn. (sweat)			**3/8 to 5/16 (8)	**3/8 to 5/16 (8)	**3/8 to 5/16 (8)	3/8 (9.5)	3/8 (9.5)
Vapor line — in. (mm) o.d. conn. (sweat)			5/8 (15.9)	5/8 (15.9)	3/4 (19.1)	3/4 (19.1)	3/4 (19.1)
Shipping weight — lbs. (kg) 1 package			152 (69)	152 (69)	161 (73)	173 (78.5)	193 (88)

*Refrigerant charge sufficient for 15 ft. (4.5 m) length of refrigerant lines.

**5/16 to 3/8 reducer coupling supplied with unit.

SPECIFICATIONS

Model No.			HP29-042-1ph	HP29-042-3ph	HP29-048	HP29-060
Outdoor Coil	Net face area - sq. ft. (m ²)	Outer coil	15.21 (1.41)	15.21 (1.41)	15.21 (1.41)	21.11 (1.96)
		Inner coil	14.50 (1.35)	5.44 (.51)	14.50 (1.35)	20.31 (1.9)
	Tube diameter — in. (mm) & no. of rows	5/16 (7.9) - 2	5/16 (7.9) - 1.37	5/16 (7.9) — 2	5/16 (7.9) — 2	
	Fins per inch (m)	18 (709)	22 (866)	18 (709)	18 (709)	
Outdoor Coil Fan	Diameter — in. (mm) & no. of blades		18 (457) - 4	18 (457) - 4	18 (457) — 4	18 (457) — 4
	Motor hp (W)		1/3 (249)	1/6 (124)	1/3 (249)	1/3 (249)
	Cfm (L/s)		2975 (1403)	2500 (1180)	3020 (1425)	4330 (2043)
	Rpm		1130	1100	1125	1075
	Watts		310	200	330	420
*Refrigerant charge furnished (HCFC-22)			8 lbs. 5 Oz. (3.76 kg)	7 lbs. 10 Oz. (3.45 kg)	7 lbs. 12 oz. (3.51 kg)	11 lbs. 13 oz. (5.34kg)
Liquid line — in. (mm) o.d. connection (sweat)			3/8 (9.5)	3/8 (9.5)	3/8 (9.5)	3/8 (9.5)
Vapor line — in. (mm) o.d. connection (sweat)			7/8 (22.2)	7/8 22.2)	7/8 (22.2)	1-1/8 (28.6)
Shipping weight — lbs. (kg) 1 package			182 (83)	199 (90.3)	190 (86.2)	254 (115.2)

*Refrigerant charge sufficient for 15 ft. (4.5 m) length of refrigerant lines.

ELECTRICAL DATA

Model No.		HP29-211-1	HP29-211-2	HP29-261-1	HP29-261-2	HP29-311	HP29-411	HP29-413	
Line voltage data — 60 hz		208/230v 1ph	208/230v 1ph	208/230v 1ph	208/230v 1ph	208/230v 1ph	208/230v 1ph	208/23v 3ph	460v 3ph
Compressor	Rated load amps	8.6	7.9	9.8	10.1	13.7	16.2	10.3	4.3
	Power factor	.97	.97	.96	.96	.92	.90	.83	.83
	Locked rotor amps	49.0	49.0	56.0	60.0	75.0	96.0	75.0	40.0
Outdoor Coil Fan Motor	Full load amps	1.1	1.1	1.1	1.1	1.1	1.1	1.1	0.55
	Locked rotor amps	1.9	1.9	1.9	1.9	1.9	1.9	1.9	1.0
Rec. maximum fuse or circuit breaker size (amps)		20	15	20	20	30	35	20	10
*Minimum circuit ampacity		11.9	11.0	13.5	13.8	18.4	21.4	14.0	6.5

*Refer to National or Canadian Electrical Code manual to determine wire, fuse and disconnect size requirements.

NOTE — Extremes of operating range are plus 10% and minus 5% of line voltage.

ELECTRICAL DATA

Model No.		HP29-461	HP29-463	HP29-511	HP29-513			HP29-651	HP29-653			
Line voltage data — 60 hz		208/230v 1ph	208/230v 3ph	460v 3ph	208/230v 1ph	208/230v 3ph	460v 3ph	575v 3ph	208/230v 1ph	208/230v 3ph	460v 3ph	575v 3ph
Compressor	Rated load amps	17.5	12.8	6.4	23.4	14.0	7.1	5.8	26.9	17.3	9.0	7.1
	Power factor	.98	.93	.93	.98	.88	.88	.88	.98	.86	.86	.86
	Locked rotor amps	92.0	87.0	44.0	110.0	91.0	46.0	37.0	123.0	128.0	64.0	51.0
Outdoor Coil Fan Motor	Full load amps	1.1	1.1	0.55	1.9	1.9	0.90	0.90	1.9	1.9	0.90	0.90
	Locked rotor amps	1.9	1.9	1.0	4.1	4.1	2.1	2.1	4.1	4.1	2.1	2.1
Rec. max. fuse or circuit breaker size (amps)		40	25	15	50	30	15	10	60	40	20	15
*Minimum circuit ampacity		23.0	17.1	8.6	31.2	19.4	9.8	8.2	35.5	23.5	12.2	9.8

*Refer to National or Canadian Electrical Code manual to determine wire, fuse and disconnect size requirements.

NOTE — Extremes of operating range are plus 10% and minus 5% of line voltage.

ELECTRICAL DATA

Model No.		HP29-018	HP29-024	HP29-030	HP29-036		
Line voltage data — 60 hz		208/230v 1ph	208/230v 1ph	208/230v 1ph	208/230v 1ph	208/230v 3ph	460v 3ph
Compressor	Rated load amps	7.9	10.1	14.7	16.0	11.0	5.6
	Power factor	.97	.96	.90	.91	.83	.83
	Locked rotor amps	49.0	60.0	84.0	100	75.0	37.5
Outdoor Coil Fan Motor	Full load amps	1.1	1.1	1.1	1.1	1.1	0.55
	Locked rotor amps	1.9	1.9	1.9	1.9	1.9	1.0
Rec. maximum fuse or circuit breaker size (amps)		15	20	30	35	20	10
*Minimum circuit ampacity		11.0	13.8	19.5	21.1	14.0	6.5

*Refer to National or Canadian Electrical Code manual to determine wire, fuse and disconnect size requirements.
NOTE — Extremes of operating range are plus 10% and minus 5% of line voltage.

ELECTRICAL DATA

Model No.		HP29-042			HP29-048				HP29-060			
Line voltage data — 60 hz		208/230v 1ph	208/230v 3ph	460v 3ph	208/230v 1ph	208/230v 3ph	460v 3ph	575v 3ph	208/230v 1ph	208/230v 3ph	460v 3ph	575v 3ph
Compressor	Rated load amps	20.3	12.8	6.4	23.7	13.5	7.4	5.8	28.8	17.3	9.0	7.1
	Power factor	.84	.93	.93	.96	.88	.88	.88	.92	.86	.86	.86
	Locked rotor amps	127	87.0	44.0	129.0	120.0	49.5	48.0	169.0	137.0	62.0	51.0
Outdoor Coil Fan Motor	Full load amps	1.9	1.1	0.55	1.9	1.9	0.90	0.90	1.9	1.9	0.90	0.90
	Locked rotor amps	4.1	1.9	1.0	4.1	4.1	2.1	2.1	4.1	4.1	2.1	2.1
Rec. maximum fuse or circuit breaker size (amps)		40	25	15	50	30	15	10	60	40	20	15
*Minimum circuit ampacity		27.3	17.1	8.6	31.5	18.8	10.2	8.2	37.4	23.5	12.2	9.8

*Refer to National or Canadian Electrical Code manual to determine wire, fuse and disconnect size requirements.
NOTE — Extremes of operating range are plus 10% and minus 5% of line voltage.

I - UNIT INFORMATION

HP29 units are available in 1 -1/2, 2, 2 -1/2, 3, 3 -1/2, 4 and 5 ton capacities.

All major components (indoor blower/coil) must be matched according to Lennox recommendations for the compressor to be covered under warranty. Refer to the Engineering Handbook for approved system matchups. A misapplied system will cause erratic operation and can result in early compressor failure.

II - UNIT COMPONENTS

Unit components are illustrated in figure 2.

A - Control Box (Figures 3, 4 and 5)

Electrical openings are provided under the control box cover. Field thermostat wiring is made to color-coded pigtail connections as illustrated in figure 1.

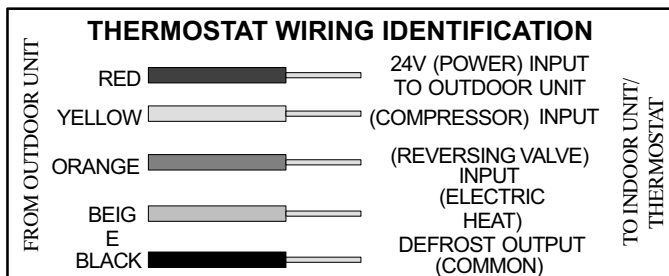

FIGURE 1

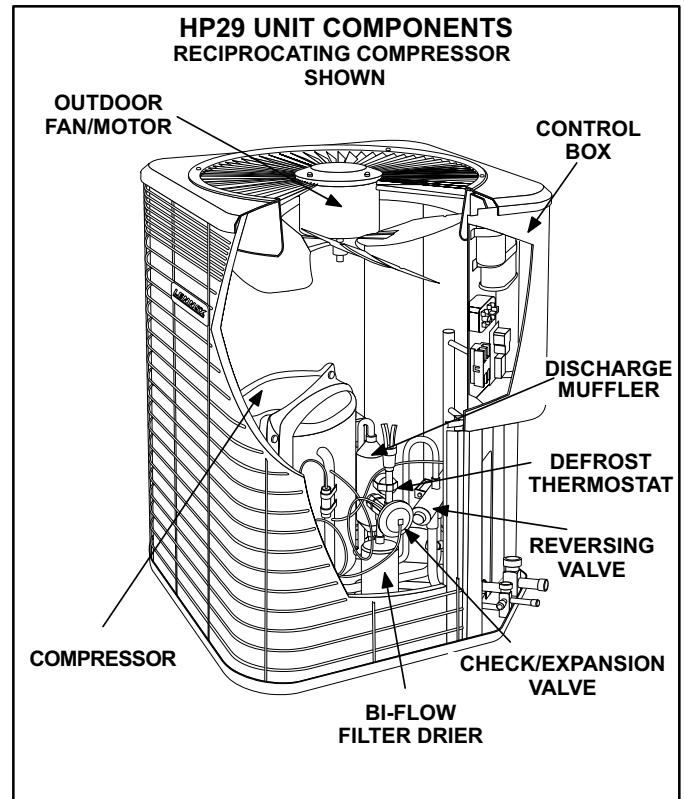

FIGURE 2

1 - Transformer T5

Transformer T5 is used on all “J” voltage units. T5 is used as a step-down transformer for the outdoor fan motor. The transformer is located inside the unit control box (see figure 3). The transformer is rated at 3.4 VA with a 575 volt primary and a 460 volt secondary.

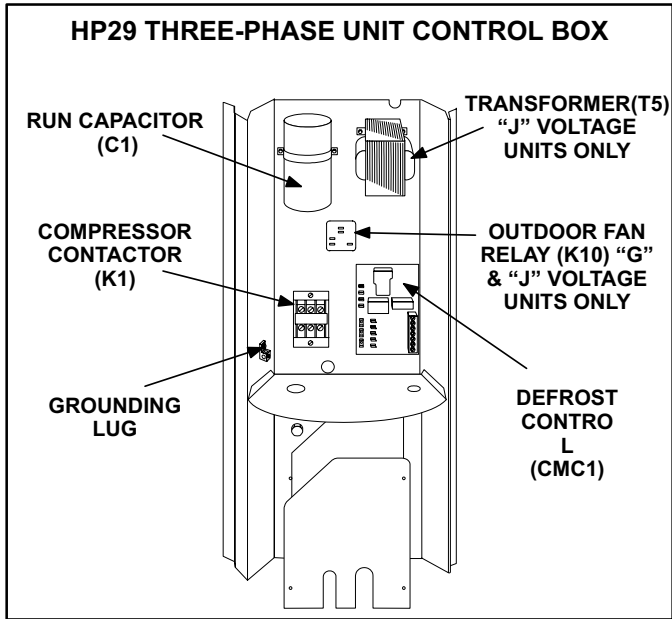

FIGURE 3

2 - Dual Capacitor C12

The compressor (scroll or reciprocating) and fan in single-phase units use permanent split capacitor motors. The capacitor is located inside the unit control box (see figure 4 and 5). A single “dual” capacitor (C12) is used for both the fan motor and the compressor (see unit wiring diagram). The fan side and the compressor side of the capacitor have different MFD ratings. See table 1 for dual capacitor ratings.

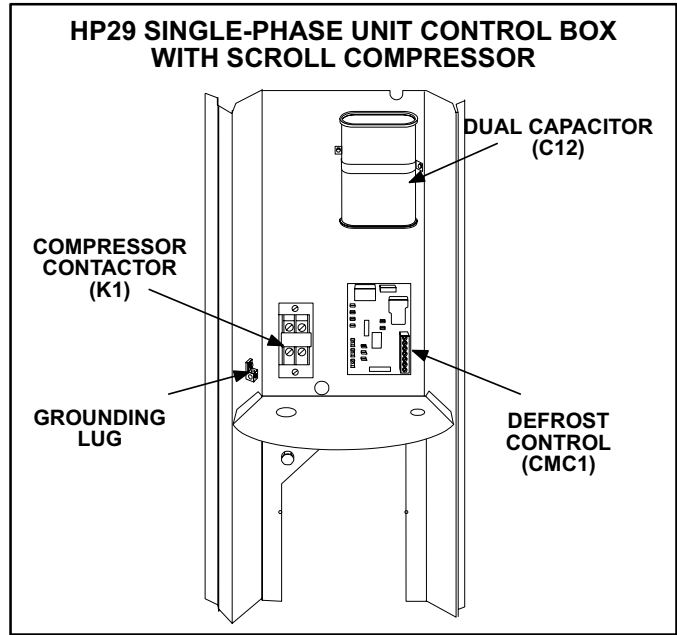

FIGURE 5

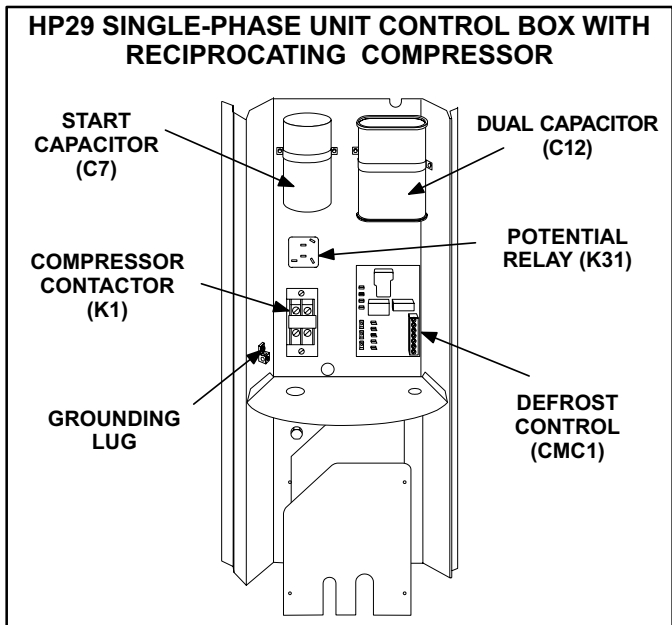

FIGURE 4

TABLE 1

HP29 (C12) DUAL CAPACITOR RATING			
Unit	Terminal	MFD	VAC
HP29-211	FAN	5	370
	HERM	25	
HP29-261	FAN	5	
	HERM	30	
HP29-311	FAN	5	
	HERM	35	
HP29-411	FAN	5	
	HERM	40	
HP29-461/511	FAN	7.5	440
	HERM	50	
HP29-651	FAN	7.5	
	HERM	70	
HP29-018	FAN	5	370
	HERM	25	
HP29-024	FAN	5	
	HERM	30	
HP29-030	FAN	5	
	HERM	35	
HP29-036	FAN	5	440
	HERM	40	
HP29-042	FAN	7.5	
	HERM	40	
HP29-048	FAN	7.5	370
	HERM	60	
HP29-060	FAN	7.5	
	HERM	80	

3 - Potential Relay K31 (Start)

All single-phase units with a **reciprocating compressor**, use a potential relay which controls the operation of the starting circuit. The potential relay is located inside the unit control box (see figure 4). The relay is normally closed when contactor K1 is de-energized. When K1 energizes, the compressor immediately begins start-up. K31 remains closed during compressor start-up and start capacitor C7 remains in the circuit. When the compressor reaches approximately 75% of its speed, K31 is energized. When K1 energizes, the contacts open and start capacitor C7 is taken out of the circuit. Potential relays are critically matched to the specific compressor applied.

4 - Start Capacitor C7

All single-phase units with a **reciprocating compressor**, use a start capacitor (C7). C7 is located inside the unit control box (see figure 4). C7 is wired in parallel with the compressor side of the dual capacitor. See table 2 for start capacitor ratings.

TABLE 2

HP29 START CAPACITOR RATING (C7)		
Unit	MFD	VAC
HP29-211/261/311	145-175	330
HP29-411	189-227	330
HP29-461/511/651	176-216	216
HP29-018/024	145-175	330

5 - Run Capacitor C1

The fan in all three-phase units uses a single-phase permanent split capacitor motor. A single capacitor C1 is used for the fan motor. C1 is located inside the unit control box (see figure 3). Table 3 shows the ratings of C1.

TABLE 3

HP29 RUN CAPACITOR RATING (C1)		
Unit	MFD	VAC
HP29-413/463/513	5	370
HP29-653	7.5	370
HP29-036	5	370
HP29-042/048/060	7.5	370

6 - Outdoor Fan Relay K10

Outdoor fan relay K10 is used on all "G" and "J" voltage units to energize the outdoor fan B4. The relay is located in the control box and is a single-pole double-throw relay. See figure 3. K10 is energized by the indoor thermostat terminal Y1 (24V). When K10 is energized, a set of N.O. contacts closes to energize the outdoor fan.

7 - Compressor Contactor K1

The compressor is energized by a contactor located in the control box. See figures 3, 4, and 5. Single-pole and two-pole contactors are used in single-phase units and three-pole contactors are used in three-phase units. See wiring diagrams for specific unit. K1 is energized by the indoor thermostat terminal Y1 (24V). Single-phase HP29 units are not equipped with a 24V transformer. All 24 VAC controls are powered by the indoor unit. Refer to unit wiring diagram. "J" voltage units only are equipped with a 24V transformer. See figure 3.

⚠ DANGER

Electric Shock Hazard.
May cause injury or death.

Disconnect all remote electrical power supplies before opening unit panel. Unit may have multiple power supplies.

Some units are equipped with single-pole contactors. When unit is equipped with a single-pole contactor, line voltage is present at all components (even when unit is not in operation).

8 - Defrost System HP29

Unit built prior to April 2002

The HP29 defrost system includes two components: a defrost thermostat and a defrost control.

ELECTROSTATIC DISCHARGE (ESD)

Precautions and Procedures

⚠ CAUTION

Electrostatic discharge can affect electronic components. Take precautions during unit installation and service to protect the unit's electronic controls. Precautions will help to avoid control exposure to electrostatic discharge by putting the unit, the control and the technician at the same electrostatic potential. Neutralize electrostatic charge by touching hand and all tools on an unpainted unit surface before performing any service procedure.

Defrost Thermostat S6

The defrost thermostat is mounted on the liquid line between the check/expansion valve and the distributor. HP29-211 through -653 have a defrost setting of 35°F (2°C) and HP29-018 through -060 have a defrost setting of 42°F (5.5°C). When defrost thermostat senses the setpoint or cooler, its contacts close and send a signal to the defrost control board to start the defrost timing. It also terminates defrost when the liquid line warms up to 70°F (21°C).

Defrost Control CMC1

The defrost control board in the HP29 series units has the combined functions of a time/temperature defrost control, defrost relay, diagnostic LEDs and field connection terminal strip.

The control provides automatic switching from normal heating operation to defrost mode and back. During compressor cycle (room thermostat demand cycle), if the "O" input is not on and the defrost thermostat is closed, the control accumulates compressor run times at 30-, 60- or 90-minute field adjustable intervals. If the defrost thermostat remains closed when the accumulated compressor run time ends, the defrost relay is energized and defrost begins.

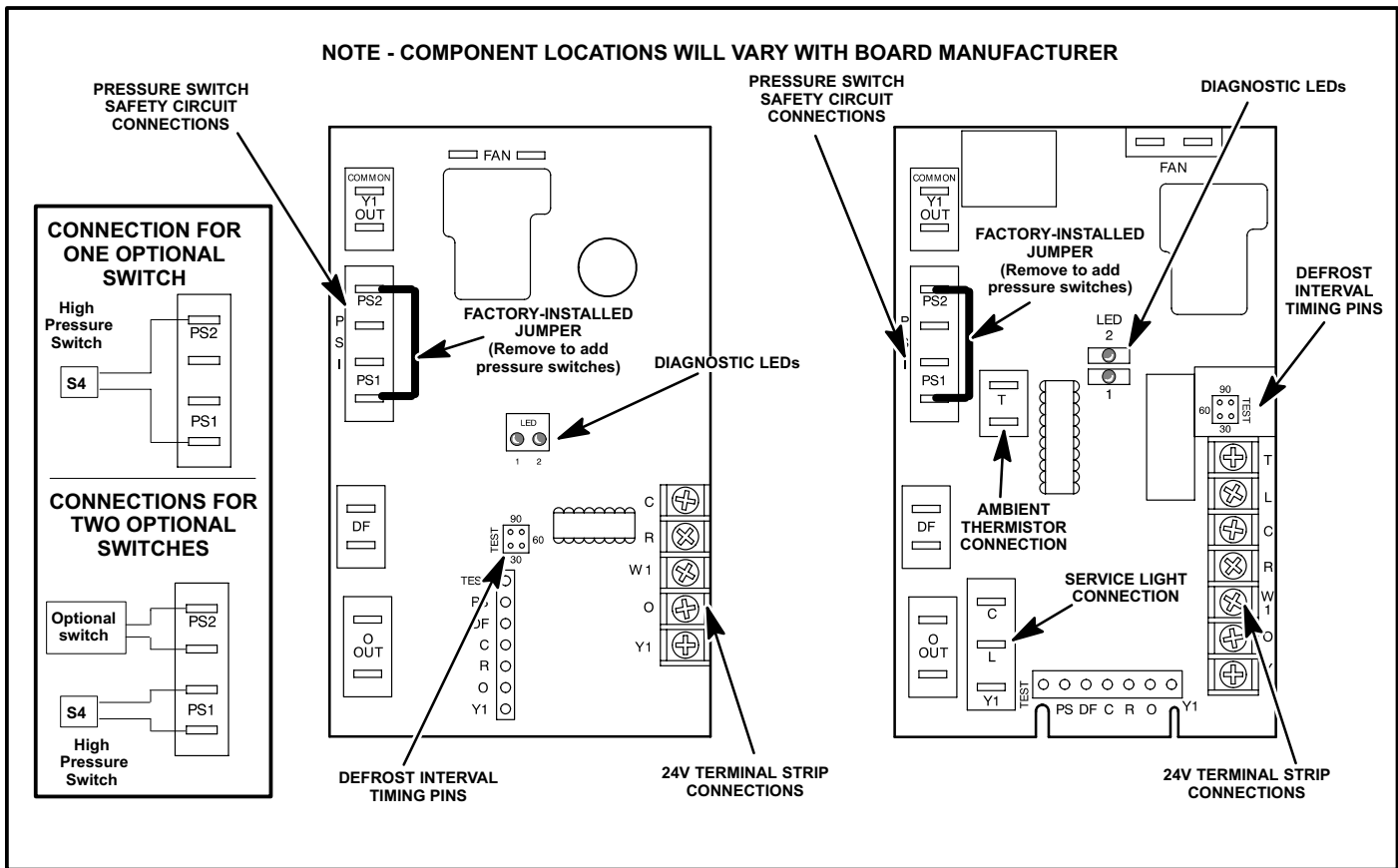

FIGURE 6

Defrost Control Timing Pins

Each timing pin selection provides a different accumulated compressor run period during one thermostat run cycle. A defrost cycle is initiated at the end of this run period. The defrost interval can be adjusted to 30, 60 or 90 minutes. See figure 6. The defrost period is a maximum of 14 minutes and cannot be adjusted. If no timing is selected, the control defaults to 90 minutes.

A TEST option is provided for troubleshooting. When the jumper is placed across the TEST pins, the timing of all functions is reduced by a factor of 128. For example, a 30 minute interval during TEST is 14 seconds and the 14 minute defrost is reduced to 6.5 seconds.

The TEST mode may be started at any time. If the jumper is in the TEST position at power-up or for longer than five minutes, the control will ignore the TEST selection and will default to a 90 minute interval. In order to test defrost cycle, defrost thermostat must be closed or jumpered. Once defrost is initiated, remove jumper immediately. Failure to remove jumper will reduce defrost cycle to approximately 3 seconds.

Pressure Switch Safety Circuit

The defrost control incorporates a pressure switch safety circuit that allows the application of up to two safety devices: high pressure and/or loss of charge. See figure 6. When the pressure switch opens, unit operation is suspended until pressure switch closes. If the pressure switch opens for a third time during one thermostat demand, the board will lockout until low voltage is reset. This can be done by breaking 24 volt power to terminal "R" on the defrost control board.

When only one pressure switch is used, wire the switch to the two outside terminals of the pressure switch connections.

NOTE: If not using a pressure switch, the factory-installed jumper wire must be connected.

Diagnostic LEDs

The defrost board uses two LEDs for diagnostics. The LEDs flash a specific sequence according to the condition.

TABLE 4

DEFROST CONTROL BOARD DIAGNOSTIC LED		
MODE	LED 1	LED 2
Normal Operation/ Power to board	Flash together with LED 2	Flash together with LED 1
Pressure Switch Open	Off	On
Board Malfunction	On	On

9 - Defrost System

Units built April 2002 and later

The HP29 defrost system includes two components: a defrost thermostat and a defrost control.

Defrost Thermostat

The defrost thermostat is located on the liquid line between the check/expansion valve and the distributor. When defrost thermostat senses 42°F (5.5°C) or cooler, the thermostat contacts close and send a signal to the defrost control board to start the defrost timing. It also terminates defrost when the liquid line warms up to 70°F (21°C).

Defrost Control

The defrost control board includes the combined functions of a time/temperature defrost control, defrost relay, diagnostic LEDs and terminal strip for field wiring connections. See figure 7.

The control provides automatic switching from normal heating operation to defrost mode and back. During compressor cycle (call for defrost), the control accumulates compressor run times at 30, 60, or 90 minute field-adjustable intervals. If the defrost thermostat is closed when the selected compressor run time interval ends, the defrost relay is energized and defrost begins.

Defrost Control Timing Pins

Each timing pin selection provides a different accumulated compressor run time period during one thermostat run cycle. This time period must occur before a defrost cycle is initiated. The defrost interval can be adjusted to 30 (T1), 60 (T2), or 90 (T3) minutes. See figure 7. The defrost timing jumper is factory-installed to provide a 60-minute defrost interval. If the timing selector jumper is not in place, the control defaults to a 90-minute defrost interval. The maximum defrost period is 14 minutes and cannot be adjusted.

A TEST option is provided for troubleshooting. **The TEST mode may be started any time the unit is in the heating mode and the defrost thermostat is closed or jumpered.** If the jumper is in the TEST position at power-up, the control will ignore the test pins. When the jumper is placed across the TEST pins for two seconds, the control will enter the defrost mode. If the jumper is removed before an additional 5-second period has elapsed (7 seconds total), the unit will remain in defrost mode until the defrost thermostat opens or 14 minutes have passed. If the jumper is not removed until after the additional 5-second period has elapsed, the defrost will terminate and the test option will not function again until the jumper is removed and re-applied.

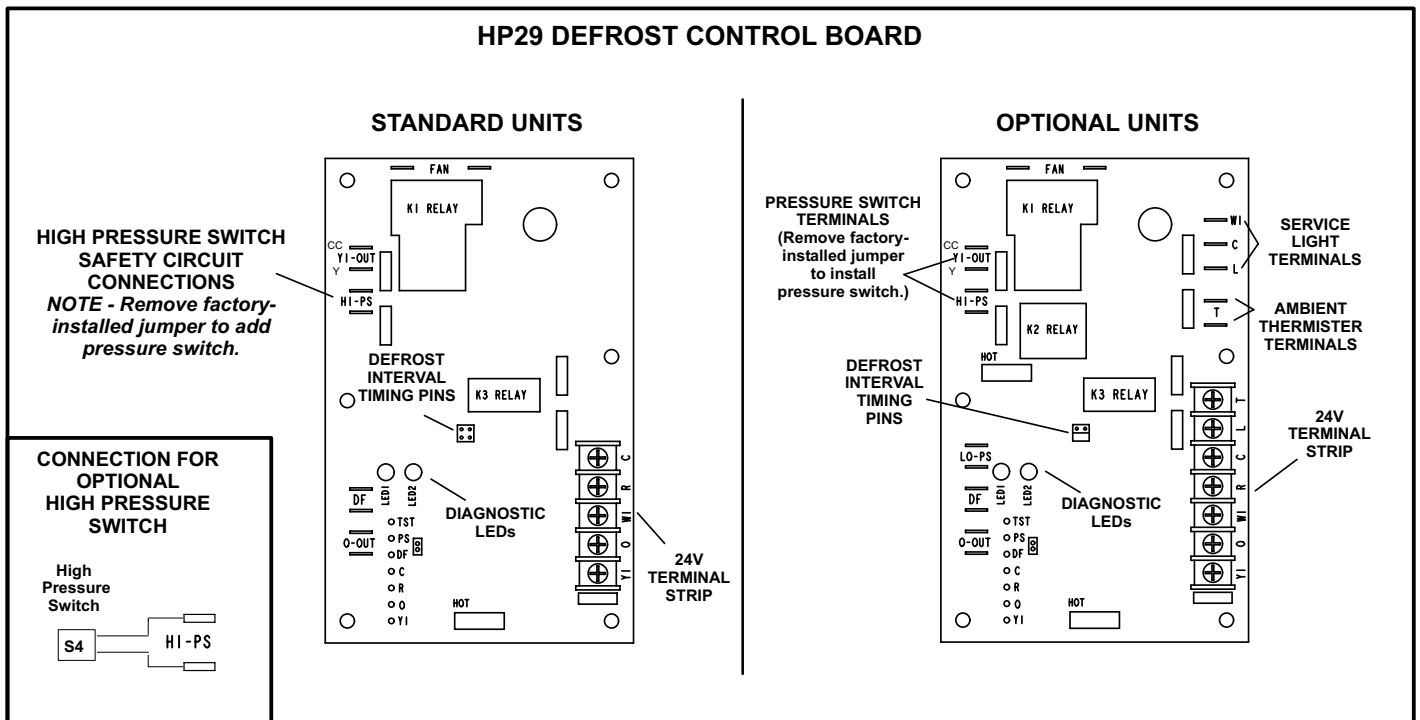

FIGURE 7

Pressure Switch Circuit

The defrost control incorporates a pressure switch circuit that allows the application of an optional high pressure switch. See figure 7. During a demand cycle, the defrost control will lock out the unit if the optional high pressure switch opens. The diagnostic LEDs will display a pattern for an open high pressure switch. See table 5. The unit will remain locked out until the switch resets or is reset.

Remove the factory-installed jumper before connecting the optional high pressure switch to the control board.

NOTE - If not using a pressure switch, the factory-installed jumper wire must be connected.

Diagnostic LEDs

The defrost board uses two LEDs for diagnostics. The LEDs flash a specific sequence according to the condition.

TABLE 5

DEFROST CONTROL BOARD DIAGNOSTIC LED		
MODE	LED 1	LED 2
Normal operation / power to board	Synchronized Flash with LED 2	Synchronized Flash with LED 1
Board failure or no power	Off	Off
Board failure	On	On
High pressure switch open	Flash	On
Low pressure switch open*	On	Flash
Pressure switch lockout*	On	Off
Anti-short-cycle / 5-minute delay*	Alternating Flash with LED 2	Alternating Flash with LED 1

*Optional units only.

Optional Units

Optional units include a defrost control which includes a timed-off delay and a second pressure switch circuit.

Time-Delay Relay

The time delay is five minutes long. The delay feature protects the compressor in case of an interruption in power to the unit. The time delay may be bypassed by placing the temperature select jumper across the TEST pins for 0.5 seconds.

Pressure Switch Circuit

The defrost control board used in optional units includes a three-strike lock-out feature and LO PS terminals to accommodate the addition of a field-provided low pressure or loss of charge pressure switch. See figure 7.

During a single demand cycle, the defrost control will lock out the unit after the third time that the circuit is interrupted by any pressure switch that is wired to the control board. In addition, the diagnostic LEDs will indicate a locked out pressure switch after the third occurrence of an open pressure switch. See table 5. The unit will remain locked out until power is broken then remade to the control or until the jumper is applied to the TEST pins for 0.5 seconds.

*NOTE - The defrost control board ignores input from the low pressure switch terminals during the TEST mode, during the defrost cycle, during a 90-second start-up period, and for the first 90 seconds each time the reversing valve switches heat/cool modes. **If the TEST pins are jumpered and the 5-minute delay is being bypassed, the LO PS terminal signal is not ignored during the 90-second start-up period.***

Ambient Thermistor & Service Light Connection

Optional units include a defrost control board which provides terminal connections for an ambient thermistor and a service light. The thermistor compensates for changes in ambient temperature which might cause thermostat droop. The service light thermostat provides a signal which activates the room thermostat service light during periods of inefficient operation.

B - Compressor (Reciprocating & Scroll)

⚠ DANGER

Make sure all power is disconnected before beginning electrical service procedures.

Some HP29 units utilize a conventional reciprocating compressor. Table 6 shows the specifications of reciprocating compressors used in HP29 series units.

TABLE 6

HP29 COMPRESSOR SPECIFICATIONS						
Unit	MAN/MODEL	Voltage	Phase	LRA	RLA	Oil fl.oz.
HP29-211	COP/CR16K6-PFV	208/230	1	49	8.6	45
HP29-211	TEC/AWD5516EXD	208/230	1	48.3	7.9	32
HP29-261	COP/CR22K6-PFV	208/230	1	56	9.8	45
HP29-261	TEC/AWD5522EXD	208/230	1	60	10.06	32
HP29-311	COP/CR28K6-PFV	208/230	1	75	13.7	45
HP29-411	COP/CR34K6-PFV	208/230	1	96	16.2	45
HP29-413	COP/CR35K6-TF5	208/230	3	75	10.3	45
HP29-413	COP/CR35K6-TFD	460	3	40	4.3	45
HP29-461	TEC/AV5540F	208/230	1	92	17.5	54
HP29-463	TEC/AV5540F	208/230	3	87	12.8	54
HP29-463	TEC/AV5540F	460	3	44	6.4	54
HP29-511	TEC/AV5545F	208/230	1	110	23.4	54
HP29-513	TEC/AV5545F	208/230	3	91	14.0	54
HP29-513	TEC/AV5545F	460	3	46	7.1	54
HP29-513	TEC/AV5545F	575	3	37	5.8	54
HP29-651	TEC/AV5558F	208/230	1	123	26.9	54
HP29-653	TEC/AV5558F	208/230	3	128	17.3	54
HP29-653	TEC/AV5558F	460	3	64	9.0	54
HP29-653	TEC/AV5558F	575	3	51	7.1	54
HP29-018	COP/CR16K6-PFV	208/230	1	49	7.9	45
HP29-024	COP/CR22K6-PFV	208/230	1	60	10.1	45
HP29-036	TEC/AVD5535EXT	208/230	3	75	10.3	54
HP29-036	TEC/AVD5535EXG	460	3	37.5	5.6	54
HP29-042	TEC/AV5540F	208/230	3	87	12.8	54
HP29-042	TEC/AV5540F	460	3	44	6.4	54

Some HP29 units utilize a scroll compressor. The scroll compressor design is simple, efficient and requires few moving parts. A cutaway diagram of the scroll compressor is shown in figure 8. The scrolls are located in the top of the compressor can and the motor is located just below. The oil level is immediately below the motor.

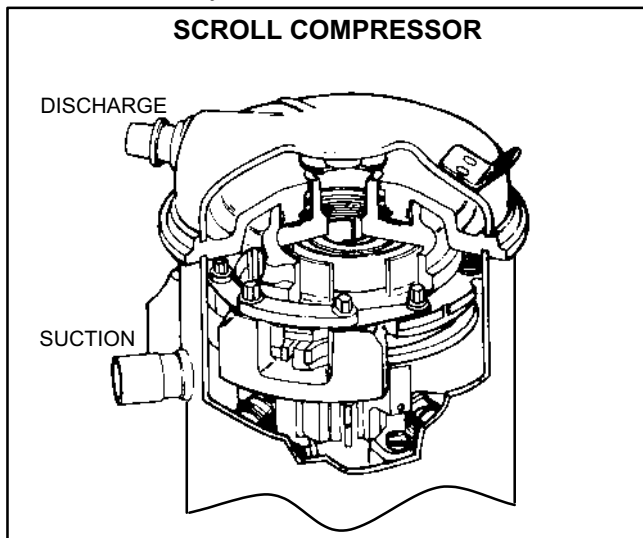

FIGURE 8

The scroll is a simple compression concept centered around the unique spiral shape of the scroll and its inherent properties. Two identical scrolls are mated together forming concentric spiral shapes. One scroll remains stationary, while the other is allowed to "orbit." The orbiting scroll does not rotate or turn but merely orbits the stationary scroll. Due to its efficiency, the scroll compressor is capable of drawing a much deeper vacuum than reciprocating compressors. Deep vacuum operation can cause internal fusite arcing resulting in damaged internal parts and will result in compressor failure. Never use a scroll compressor for evacuating or for deep vacuum operation (operating compressor at 0 psig or lower) on the system. Table 7 shows the specifications of scroll compressors used in the HP29 series units.

TABLE 7

HP29 COMPRESSOR SPECIFICATIONS						
Unit	MAN/MODEL	Voltage	Phase	LRA	RLA	Oil fl.oz.
HP29-030	COP/ZR30KC-PFV	208/230	1	84	14.7	42
HP29-036	COP/ZR36KC-PFV	208/230	1	100	16	42
HP29-042	COP/ZR42KC-PFV	208/230	1	127	20.3	42
HP29-048	COP/ZR46K3-PFV	208/230	1	129	23.7	66
HP29-048	COP/ZR46K3-TF5	208/230	3	120	13.5	72
HP29-048	COP/ZR46K3-TFD	460	3	49.5	7.4	72
HP29-048	COP/ZR46K3-TFE	575	3	40	5.8	72
HP29-060	COP/ZR61K3-PFV	208/230	1	169	28.8	56
HP29-060	COP/ZR61K3-TF5	208/230	3	137	17.3	72
HP29-060	COP/ZR61K3-TFD	460	3	62	9	72
HP29-060	COP/ZR61K3-TFE	575	3	50	7.1	72

Three-Phase Compressor Rotation

Three-phase scroll compressors must be phased sequentially to ensure correct compressor rotation and operation. At compressor start-up, a rise in discharge and drop in suction pressures indicates proper compressor phasing and operation. If discharge and suction pressures do not perform normally, follow the steps below to correctly phase the unit.

- 1 - Disconnect power to the unit.
- 2 - Reverse any two field power leads to the unit.
- 3 - Reapply power to the unit.

Discharge and suction pressures should operate within their normal start-up ranges.

NOTE - Compressor noise level may be significantly higher when phasing is incorrect and the unit will not provide cooling when compressor is operating backwards. Continued backward operation will cause the compressor to cycle on internal protector.

1 - Compressor Cover (Figure 9)

A compressor cover constructed of vinyl-faced fiberglass is used on all HP29 units. The cover provides an acoustic barrier. The cover slides over the compressor and is held secure with snap buttons. Slits are provided for installation around the discharge and suction lines.

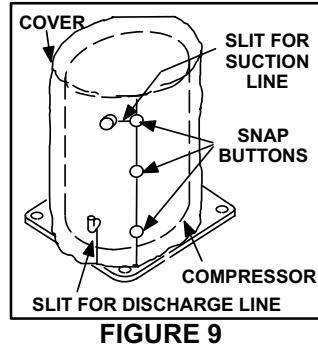

FIGURE 9

2 - Crankcase Heater

A crankcase heater is used on all HP29 units equipped with a **reciprocating compressor**. The well-mounted insertion-type heater is self-regulating. See table 8 for crankcase heater specifications.

TABLE 8

HP29 CRANKCASE HEATER RATINGS	
Unit	Rating (Watts)
HP29-211/-261/-311/-410	40 watts
HP29-460,-510 and -650	27 watts
HP29-018/-024/-030	40 watts
HP29-042	27 watts

C - Condenser Fan Motor

All units use single-phase PSC fan motors which require a run capacitor. In all HP29 units, (except "G" and "J" voltage) the outdoor fan is controlled by the CMCI defrost board.

ELECTRICAL DATA tables in this manual show specifications for outdoor fans used in HP29s.

Access to the outdoor fan motor on all units is gained by removing the seven screws securing the fan assembly. See figure 10. The outdoor fan motor is removed from the fan guard by removing the four nuts found on the top panel. If condenser fan motor must be replaced, align fan hub flush with motor shaft.

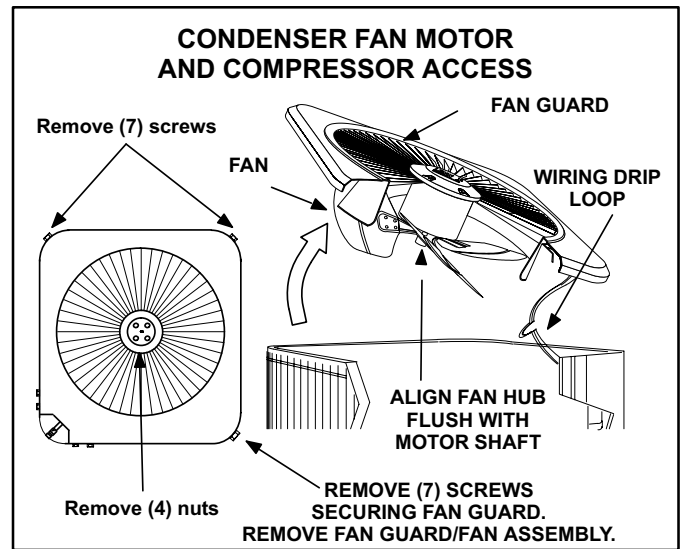

FIGURE 10

D - Reversing Valve L1 and Solenoid

A refrigerant reversing valve with electromechanical solenoid is used to reverse refrigerant flow during unit operation. The reversing valve requires no maintenance. It is not repairable. If the reversing valve has failed, it must be replaced.

If replacement is necessary, access reversing valve by removing the outdoor fan motor. Refer to figure 10.

III - REFRIGERANT SYSTEM

Refer to figure 11 for refrigerant flow in the cooling modes. The reversing valve is energized during cooling demand and during defrost.

A - Liquid and Vapor Line Service Valves

The liquid and vapor line service valves (figures 12 and 13) and gauge ports are accessible from outside the unit.

Each valve is equipped with a service port. The service ports are used for leak testing, evacuating, charging and checking charge. A schrader valve is factory installed. A service port cap is supplied to protect the schrader valve from contamination and serve as the primary leak seal.

NOTE-Always keep valve stem caps clean.

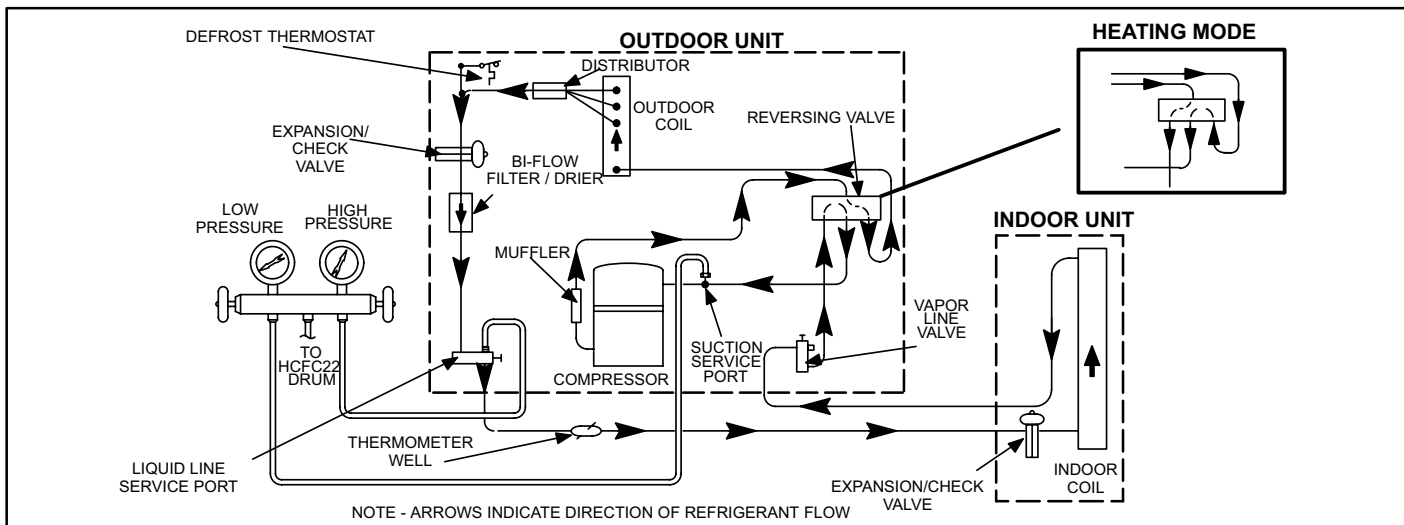

FIGURE 11

! IMPORTANT

Service valves are closed to the heat pump unit and open to line set connections. Do not open until refrigerant lines have been leak tested and evacuated. All precautions should be exercised to keep the system free from dirt, moisture and air.

To Access Schrader Port:

- 1 - Remove service port cap with an adjustable wrench.
- 2 - Connect gauge to the service port.
- 3 - When testing is completed, replace service port cap. Tighten finger tight, then an additional 1/6 turn.

To Open Liquid or Vapor Line Service Valve:

- 1 - Remove stem cap with an adjustable wrench.
- 2 - Using service wrench and hex head extension (5/16 for vapor line and 3/16 for liquid line), back the stem out counterclockwise until the valve stem just touches the retaining ring.
- 3 - Replace stem cap tighten firmly. Tighten finger tight, then tighten an additional 1/6 turn.

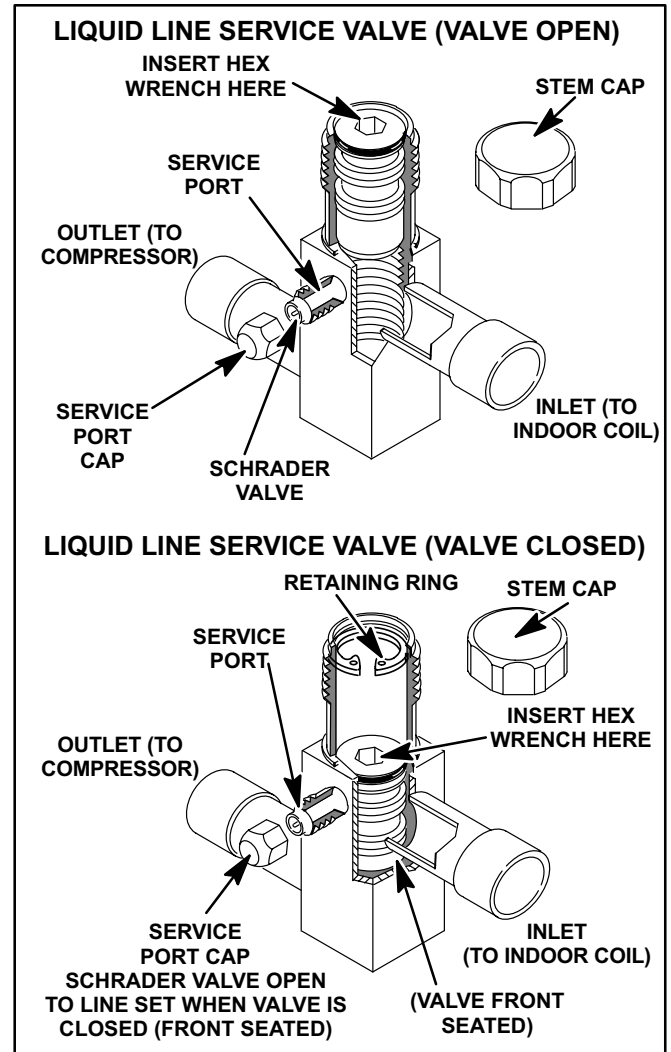

FIGURE 12

! DANGER

Do not attempt to backseat this valve. Attempts to backseat this valve will cause snap ring to explode from valve body under pressure of refrigerant. Personal injury and unit damage will result.

To Close Liquid or Vapor Line Service Valve:

- 1 - Remove stem cap with an adjustable wrench.
- 2 - Using service wrench and hex head extension (5/16 for vapor line and 3/16 for liquid line), turn stem clockwise to seat the valve. Tighten firmly.
- 3 - Replace stem cap. Tighten finger tight, then tighten an additional 1/6 turn.

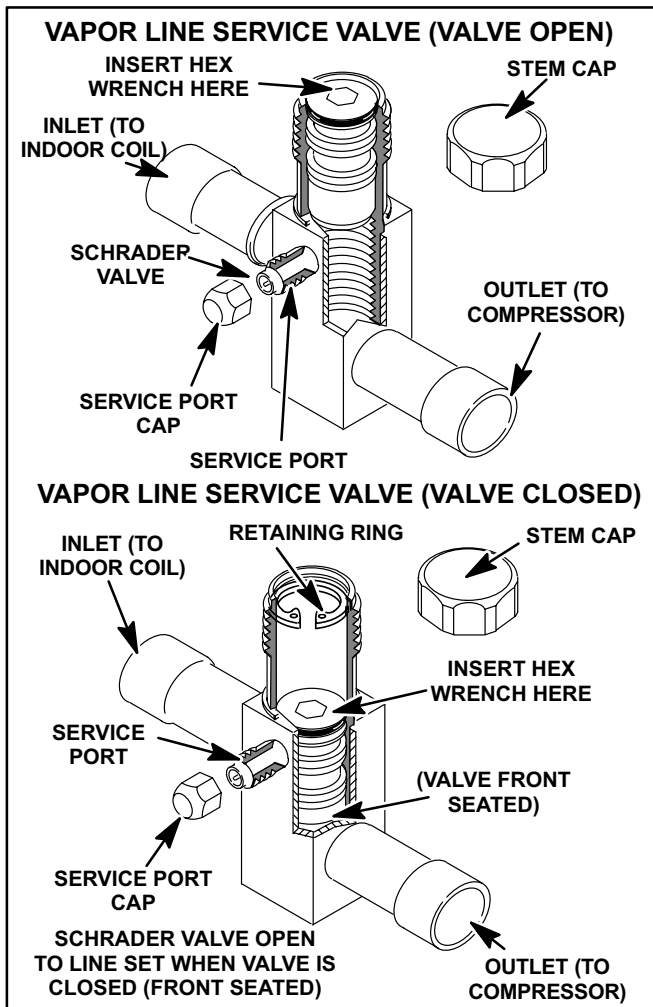

FIGURE 13

Vapor Line (Ball Type) Service Valve(5 Ton Only)

A ball-type full service valve is used on HP29 5 ton units. These vapor line service valves function the same way, differences are in construction. Valves are not rebuildable. If a valve has failed it must be replaced. A ball valve is illustrated in figure 14.

The ball valve is equipped with a service port. A schrader valve is factory installed. A service port cap is supplied to protect the schrader valve from contamination and assure a leak free seal.

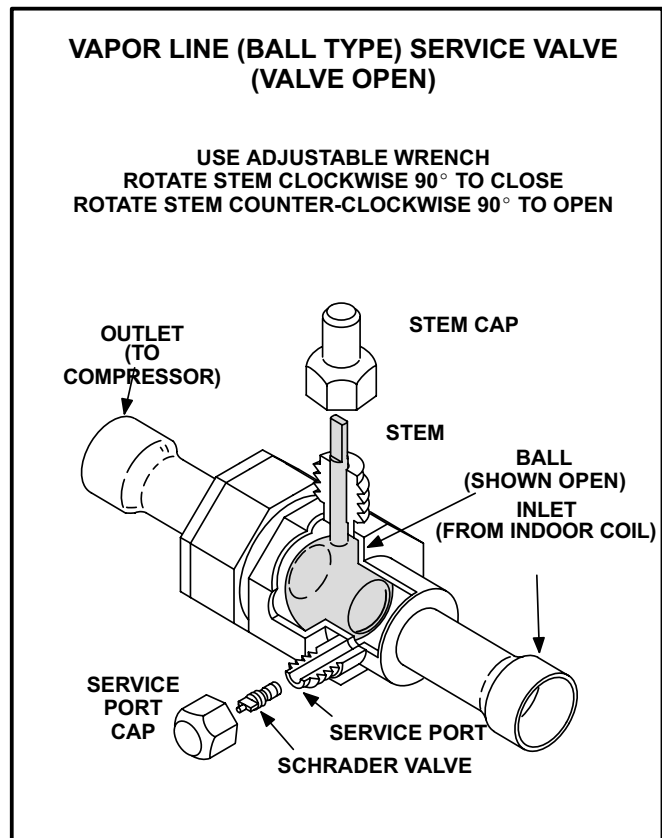

FIGURE 14

B - Plumbing

See figure 15 for unit refrigerant components. Field refrigerant piping consists of liquid and vapor lines from the outdoor unit (sweat connections). Use Lennox L10 (flare) or L15 (sweat, non-flare) series line sets as shown in table 9 or use field-fabricated refrigerant lines.

TABLE 9

Outdoor Unit Model No.	Line Set Model No. (L10 or L15)	Length of Lines		Liquid Line Outside Dia.		Vapor Line Outside Dia.	
		ft.	m	in.	mm	in.	mm
HP29-211 HP29-261 HP29-018 HP29-024	L10/15-21-20	20	6	5/16	7.9	5/8	15.9
	L10/15-21-25	25	8				
	L10/15-21-35	35	11				
	L10/15-21-50	50	15				
HP29-311 HP29-030	L15-31-20	20	6	5/16	7.9	3/4	19
	L15-31-30	30	9				
	L15-31-40	40	12				
	L15-31-50	50	15				
HP29-410 HP29-036	L10/15-41-20	20	6	3/8	9.5	3/4	19
	L10/15-41-30	30	9				
	L10/15-41-40	40	12				
	L10/15-41-50	50	15				
HP29-460 HP29-510 HP29-042 HP29-048	L10/15-65-30	30	9	3/8	9.5	7/8	22.2
	L10/15-65-40	40	12				
	L10/15-65-50	50	15				
HP29-650 HP29-060	*Field fabricated			3/8	9.5	1-1/8	28.5

*Field fabricate.

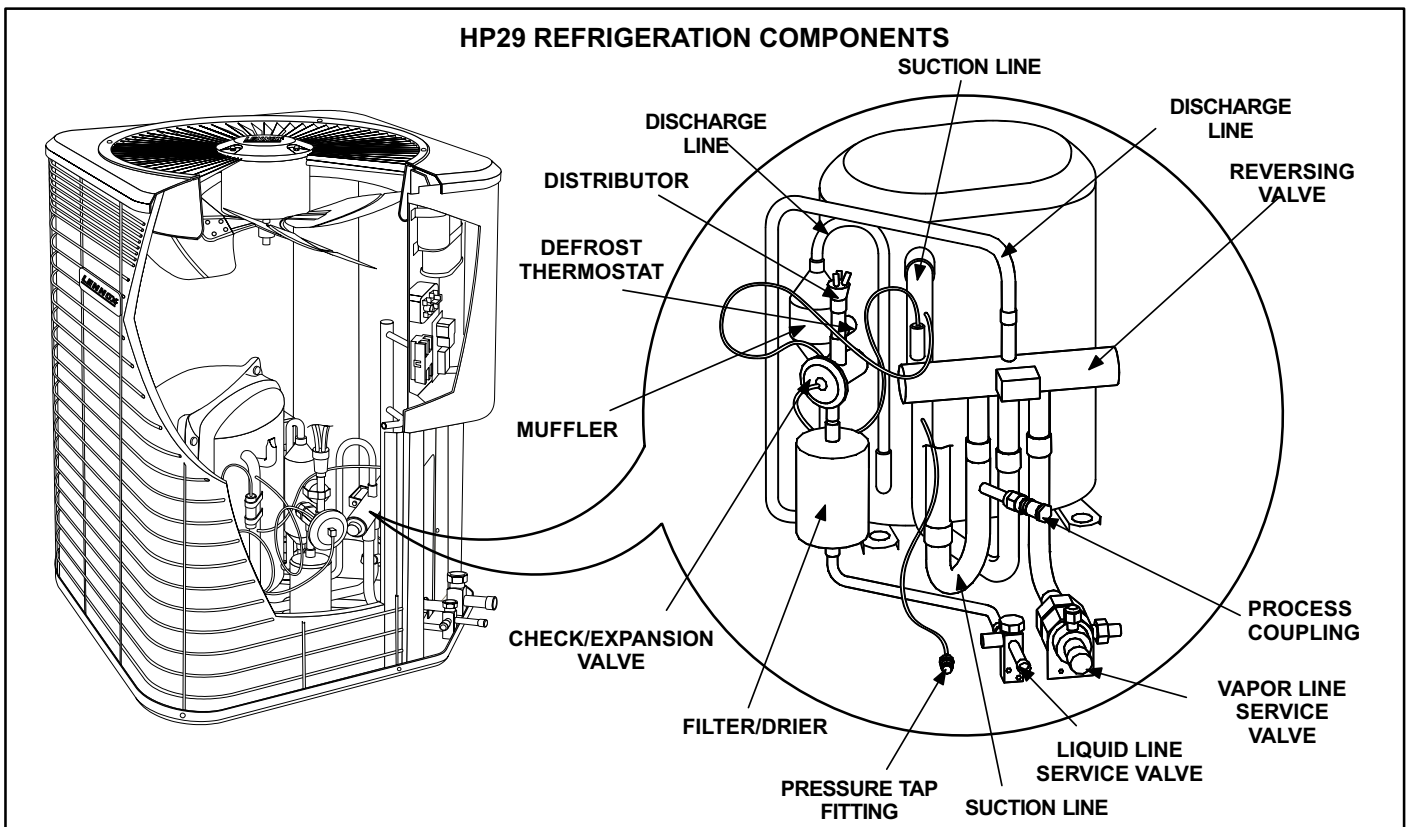

FIGURE 15

IV - CHARGING

Unit charge is based on a matching indoor coil and outdoor coil with a 15 foot (4.5 m) line set. For varying lengths of line set, refer to table 10.

TABLE 10

Liquid Line Set Diameter	Ounce per 5 foot (ml per mm) adjust from 15 ft. (4.5 m)*
5/16 in. (8mm)	2 ounce per 5 feet (60 ml per 1524 mm)
3/8 in. (10 mm)	3 ounce per 5 feet (90 ml per 1524 mm)

*If line set is greater than 15 ft. (4.5m) add this amount. If line set is less than 15 ft. (4.5m) subtract this amount

A - Pumping Down System

! CAUTION

Deep vacuum operation (operating compressor at 0 psig or lower) can cause internal fuseite arcing resulting in a damaged or failed compressor. This type of damage will result in denial of warranty claim.

The system may be pumped down when leak checking the line set and indoor coil or making repairs to the line set or indoor coil.

- 1 - Attach gauge manifold.
- 2 - Front seat (close) liquid line valve.
- 3 - Start outdoor unit in cooling mode.
- 4 - Monitor suction gauge. Stop unit when 0 psig is reached.
- 5 - Front seat (close) suction line valve.

B - Leak Testing (To Be Done Before Evacuating)

- 1 - Add small amount of refrigerant (3 to 5 psig) to the system.
- 2 - Attach gauge manifold and connect a drum of dry nitrogen to center port of gauge manifold.
- 3 - Pressurize the system to 150 psig.

! CAUTION

When using dry nitrogen, a pressure reducing regulator must be used to prevent excessive pressure in gauge manifold, connecting hoses, and within the system. Regulator setting must not exceed 150 psig (1034 kpa). Failure to use a regulator can cause equipment failure resulting in injury.

NOTE-Electronic leak or Halide detector should be used. Add a small amount of HCFC22 (3 to 5 psig (20kPa to 34kPa)) then pressurize with nitrogen to 150 psig.

C - Evacuating the System

! IMPORTANT

The compressor should never be used to evacuate a refrigeration or air conditioning system.

- 1 - Attach gauge manifold. Connect vacuum pump (with vacuum gauge) to center port of gauge manifold. With both manifold service valves open, start pump and evacuate indoor coil and refrigerant lines.

! IMPORTANT

A temperature vacuum gauge, mercury vacuum (U-tube), or thermocouple gauge should be used. The usual Bourdon tube gauges are not accurate enough in the vacuum range.

- 2 - Evacuate the system to 29 inches (737mm) vacuum. During the early stages of evacuation, it is desirable to stop the vacuum pump at least once to determine if there is a rapid loss of vacuum. A rapid loss of vacuum would indicate a leak in the system and a repeat of the leak testing section would be necessary.
- 3 - After evacuating system to 29 inches (737mm), close gauge manifold valves to center port, stop vacuum pump and disconnect from gauge manifold. Attach an upright nitrogen drum to center port of gauge manifold and open drum valve slightly to purge line at manifold. Break vacuum in system with nitrogen pressure by opening manifold high pressure valve. Close manifold high pressure valve to center port.
- 4 - Close nitrogen drum valve and disconnect from gauge manifold center port. Release nitrogen pressure from system.
- 5 - Connect vacuum pump to gauge manifold center port. Evacuate system through manifold service valves until vacuum in system does not rise above .5mm of mercury absolute pressure or 500 microns within a 20-minute period after stopping vacuum pump.
- 6 - After evacuation is complete, close manifold center port, and connect refrigerant drum. Pressurize system slightly with refrigerant to break vacuum.

D - Charging

Charging must be done in the cooling mode. If system is completely void of refrigerant, the recommended and most accurate method of charging is to weigh the refrigerant into the unit according to the total amount shown on the unit nameplate.

If weighing facilities are not available or if unit is just low on charge, the following procedure applies.

Separate discharge and vapor line service ports are provided outside the unit for connection of gauge manifold during charging procedure as well as a suction line service port.

! IMPORTANT

The following procedures require accurate readings of ambient (outdoor) temperature, liquid temperature and liquid pressure for proper charging. Use a thermometer with accuracy of $\pm 2^{\circ}\text{F}$ ($\pm 1.1^{\circ}\text{C}$) and a pressure gauge with accuracy of $\pm 5\text{PSIG}$ ($\pm 34.5\text{kPa}$)

1 - Expansion Valve Systems

The following procedures are intended as a general guide for use with expansion valve systems only. For best results, indoor temperature should be between 70 °F and 80 °F (21.1 °C and 26.6 °C) . If outdoor temperature is 60 °F (16 °C) or above the approach method of charging is used. If outdoor temperature is less than 60 °F (16 °C) the subcooling method of charging is used. Slight variations in charging temperature and pressure should be expected. Large variations may indicate a need for further servicing.

APPROACH METHOD (TXV SYSTEMS)

(Ambient Temperature of 60°F [16°C] or Above)

- 1 - Connect gauge manifold. Connect an upright HCFC22 drum to center port of gauge manifold.
- 2 - Record outdoor air (ambient) temperature.
- 3 - Operate indoor and outdoor units in cooling mode. Allow outdoor unit to run until system pressures stabilize.
- 4 - Make sure thermometer well is filled with mineral oil before checking liquid line temperature.
- 5 - Place thermometer in well and read liquid line temperature. Liquid line temperature should be warmer than the outdoor air temperature. Tables 11 and 12 shows how many degrees warmer the liquid line temperature should be.
Add refrigerant to lower the liquid line temperature. Recover refrigerant to raise the liquid line temperature.
Add refrigerant slowly as the unit approaches the correct temperature. This will allow refrigerant to stabilize allowing the correct temperature to be read.

TABLE 11

APPROACH METHOD AMBIENT TEMPERATURE OF 60 °F (16 °C) OR ABOVE	
Model	Liquid Line °F Warmer Than Outside (Ambient) Temperature
HP29-211	10°F (5.6°C)
HP29-261	13°F (7.2°C)
HP29-311	16°F (8.9°C)
HP29-411	12°F (6.6°C)
HP29-461	13°F (7.2°C)
HP29-511	16°F (8.9°C)
HP29-651	18°F (10°C)

TABLE 12

APPROACH METHOD AMBIENT TEMPERATURE OF 60 °F (16 °C) OR ABOVE	
Model	Liquid Line °F Warmer Than Outside (Ambient) Temperature
HP29-018	10°F (5.6°C)
HP29-024	13°F (7.2°C)
HP29-030	8°F (4.4°C)
HP29-036	13°F (7.2°C)
HP29-042	13°F (7.2°C)
HP29-048	15°F (8.3°C)
HP29-060	8°F (4.4°C)

SUBCOOLING METHOD (TXV SYSTEMS) (Ambient Temperature Below 60°F [16°C])

NOTE- It may be necessary to restrict air flow in order to reach liquid pressures in the 200-250 psig range which are required for checking charge. The indoor temperature should be above 70°F(21°C). Block equal sections of air intake panels as shown in figure 16, moving obstructions sideways until liquid pressures in the 200-250 psig range are reached.

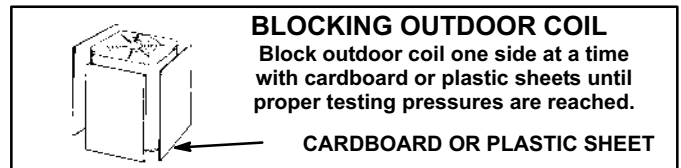

FIGURE 16

- 1 - Connect gauge manifold. Connect an upright HCFC22 drum to center port of gauge manifold.
- 2 - Operate indoor and outdoor units in cooling mode. Allow outdoor unit to run until system pressures stabilize.
- 3 - Make sure thermometer well is filled with mineral oil before checking liquid line temperature.
- 4 - Read liquid line pressure and convert to condensing temperature using temperature/ pressure conversion chart.
Condensing temperature (read from gauges) should be warmer than the liquid line temperature.
- 5 - Place thermometer in well and read liquid line temperature. Tables 13 and 14 shows how much warmer the condensing temperature should be.
Add refrigerant to lower liquid line temperature.
Recover refrigerant to raise liquid line temperature.
- 6 - When unit is properly charged liquid line pressures should approximate those given in tables 15 and 16 .

TABLE 13

SUBCOOLING METHOD AMBIENT TEMPERATURE BELOW 60 °F (16 °C)	
Model	Condensing Temp°F Warmer Than Liquid Line
HP29-211	8°F (4.4°C)
HP29-261	6°F (3.3°C)
HP29-311	10°F (5.6°C)
HP29-411	8°F (4.4°C)
HP29-461	12°F (6.7°C)
HP29-511	13°F (7.2°C)
HP29-651	5°F (2.8°C)

TABLE 14

SUBCOOLING METHOD AMBIENT TEMPERATURE BELOW 60 °F (16 °C)	
Model	Condensing Temp°F Warmer Than Liquid Line
HP29-018	8°F (4.4°C)
HP29-024	4°F (2.2°C)
HP29-030	11°F (6.1)
HP29-036	10°F (5.6°C)
HP29-042	12°F (6.7°C)
HP29-048	7°F (3.9°C)
HP29-060	10°F (5.6°C)

TABLE 15

HP29 NORMAL OPERATING PRESSURES*														
OUTDOOR COIL ENTERING AIR TEMPERATURE	HP29-211		HP29-261		HP29-311		HP29-411		HP29-461		HP29-511		HP29-651	
	LIQ. + 10 PSIG	VAP. + 10 PSIG	LIQ. + 10 PSIG	VAP. + 10 PSIG	LIQ. + 10 PSIG	VAP. + 10 PSIG	LIQ. + 10 PSIG	VAP. + 10 PSIG	LIQ. + 10 PSIG	VAP. + 10 PSIG	LIQ. + 10 PSIG	VAP. + 10 PSIG	LIQ. + 10 PSIG	VAP. + 10 PSIG
	65° F (TXV)	148	71	156	70	165	73	171	68	173	69	163	74	166
75° F (TXV)	171	74	182	72	195	75	197	70	203	71	191	75	195	73
85° F (TXV)	200	76	210	74	220	77	228	72	233	73	225	76	227	74
95° F (TXV)	230	78	241	75	254	79	261	74	267	75	259	78	261	76
105° F (TXV)	263	81	275	78	292	81	299	77	307	77	295	79	302	78

*These are typical pressures only. Indoor evaporator match up, indoor air quality and evaporator load will cause the pressures to vary.

TABLE 16

HP29 NORMAL OPERATING PRESSURES																
MODE	OUTDOOR COIL AIR ENTERING TEMP. °F (°C)	HP29-018		HP29-024		HP29-030		HP29-036		HP29-042		HP29-048		HP29-060		
		LIQ. +10 PSIG	SUC. +5 PSIG	LIQ. +10 PSIG	SUC. +5 PSIG	LIQ. +10 PSIG	SUC. +5 PSIG	LIQ. +10 PSIG	SUC. +5 PSIG	LIQ. +10 PSIG	SUC. +5 PSIG	LIQ. +10 PSIG	SUC. +5 PSIG	LIQ. +10 PSIG	SUC. +5 PSIG	
Cooling TXV Only	75 (24)	171	74	182	72	184	71	184	74	180	71	180	70	183	72	
	85 (29)	200	76	210	74	214	72	215	75	205	74	210	70	214	73	
	95 (35)	230	78	241	75	246	74	249	76	245	75	240	71	248	75	
	105 (41)	263	81	275	78	282	45	285	76	280	76	280	72	285	77	
Heating	20 (-7)	166	33	170	28	186	28	170	27	180	30	175	25	186	25	
	30 (-1)	177	42	184	36	198	36	180	38	190	40	185	35	200	32	
	40 (4)	188	51	194	42	210	43	230	50	195	47	195	43	212	42	
	50 (10)	200	61	212	56	218	53	240	55	205	54	206	52	224	50	

* These are typical pressures only. Indoor evaporator match up, indoor air quality and evaporator load will cause the pressures to vary.

⚠ IMPORTANT

Use tables 15 and 16 as a general guide for performing maintenance checks. Table is not a procedure for charging the system. Minor variations in pressures may be expected due to differences in installations. Significant deviations may mean the system is not properly charged or that a problem exists with some component in the system. Used prudently, tables 15 and 16 could serve as a useful service guide.

⚠ IMPORTANT

If insufficient heating or cooling occurs, the unit should be gauged and refrigerant charge checked.

E - Oil Charge

Refer to tables 6 and 7 on page 7.

V - MAINTENANCE

At the beginning of each heating or cooling season, the system should be cleaned as follows:

A - Outdoor Unit

- 1 - Clean and inspect outdoor coil. (Coil may be flushed with a water hose).
- 2 - Visually inspect all connecting lines, joints and coils for evidence of oil leaks.

B - Indoor Coil

- 1 - Clean coil if necessary.
- 2 - Check connecting lines and coil for evidence of oil leaks.
- 3 - Check condensate line and clean if necessary.

C - Indoor Unit

- 1 - Clean or change filters.
- 2 - Bearings are pre-lubricated and need no further oiling.
- 3 - Check all wiring for loose connections.
- 4 - Check for correct voltage at unit.
- 5 - Check amp-draw on blower motor.
Unit nameplate _____ Actual _____.

VI - REFRIGERANT LINE NOISE

It is important to properly isolate the refrigerant lines to prevent unnecessary vibration. Line set contact with the structure (wall, ceiling or floor) causes some objectionable noise when vibration is translated into sound.

The following illustrations demonstrates procedures which

ensure proper refrigerant line set isolation. Figure 17 shows how to install line sets on vertical runs. Figure 18 shows how to install line sets on horizontal runs. Figure 19 shows how to make a transition from horizontal to vertical. Finally, figure 20 shows how to place the outdoor unit and line set.

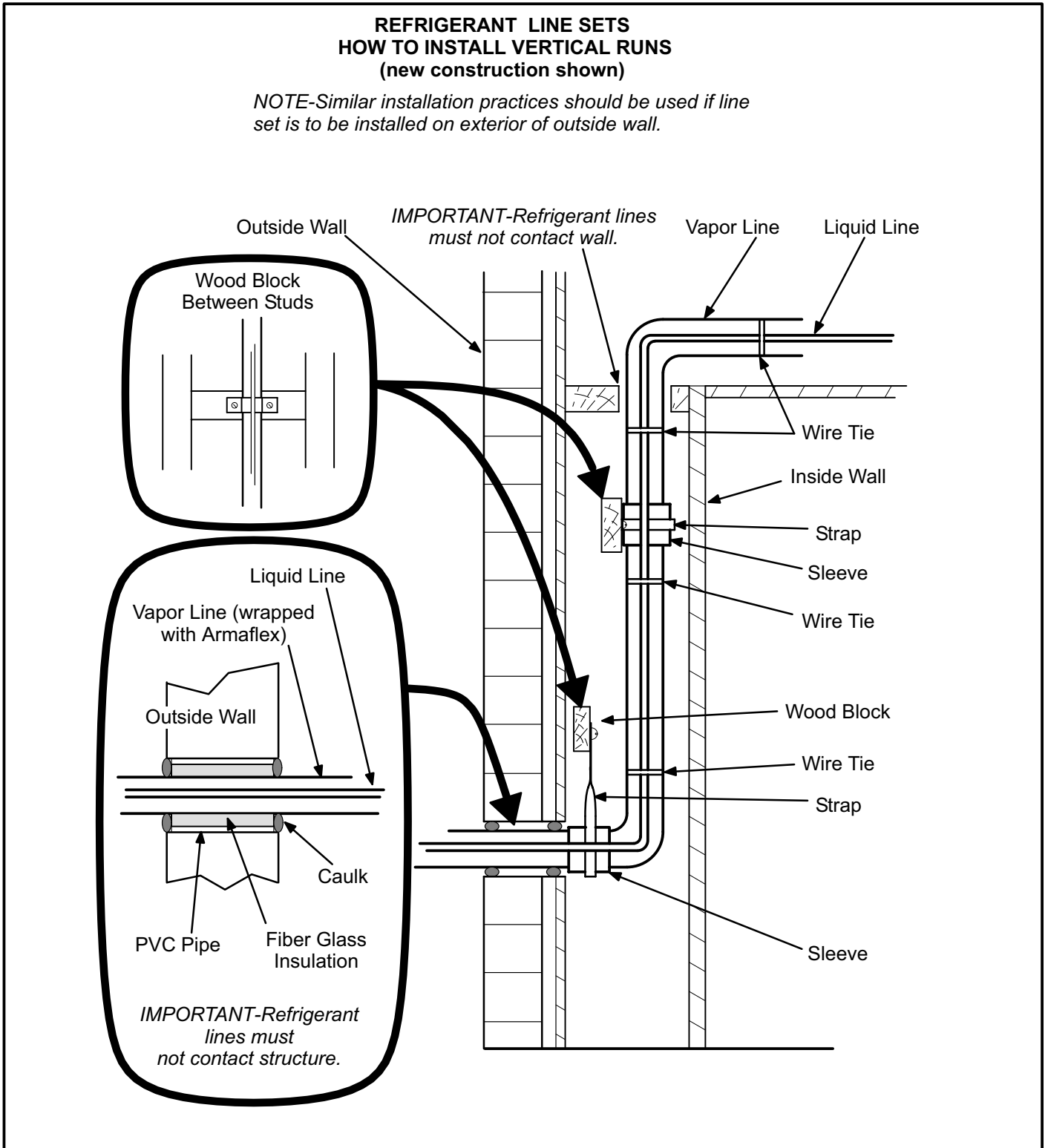

**REFRIGERANT LINE SETS:
HOW TO INSTALL HORIZONTAL RUNS**

To hang line set from joist or rafter, use either metal strapping material or anchored heavy nylon wire ties.

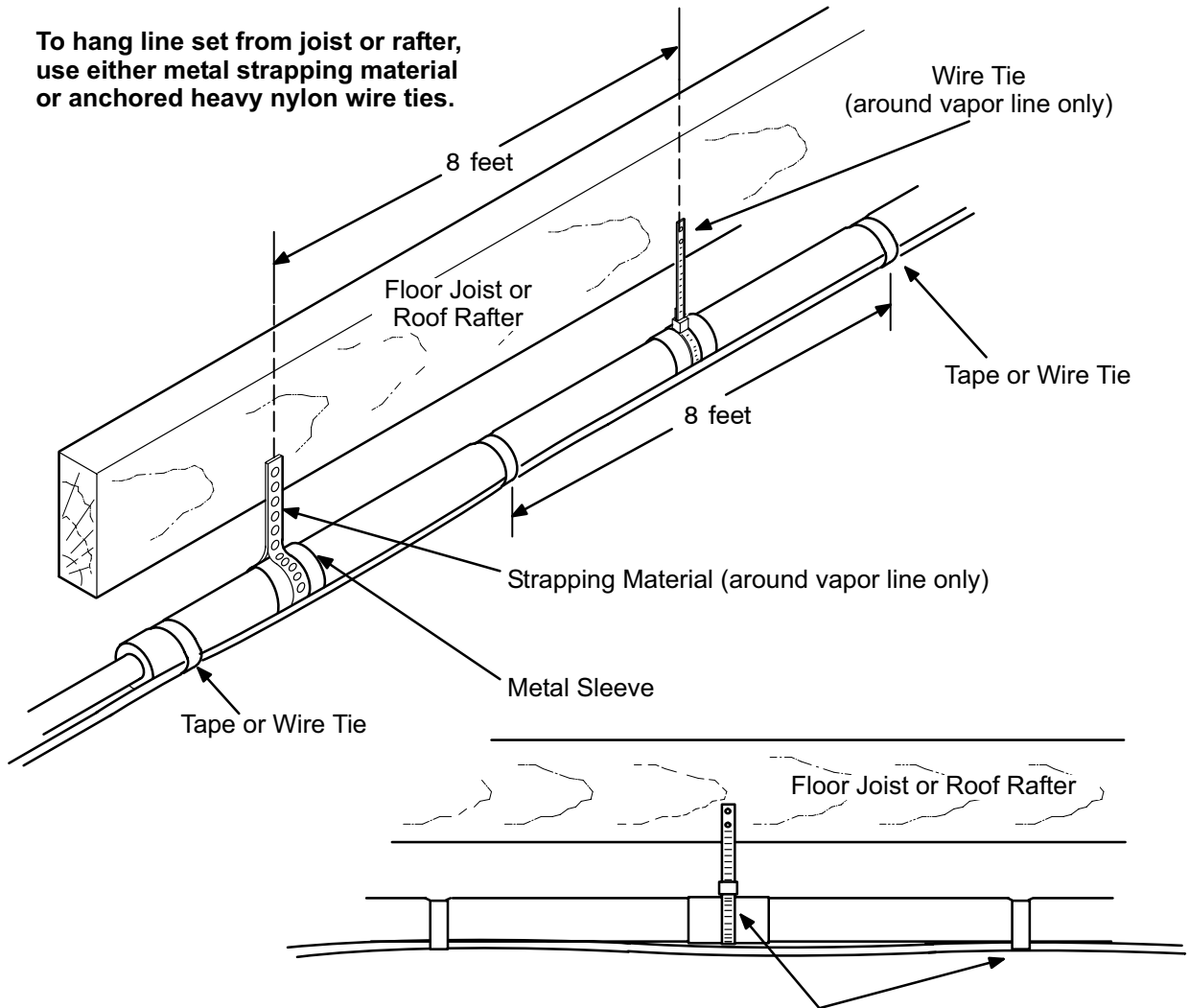

Strap the vapor line to the joist or rafter at 8 ft. intervals then strap the liquid line to the vapor line.

FIGURE 18

**HOW TO MAKE TRANSITION FROM
VERTICAL TO HORIZONTAL**

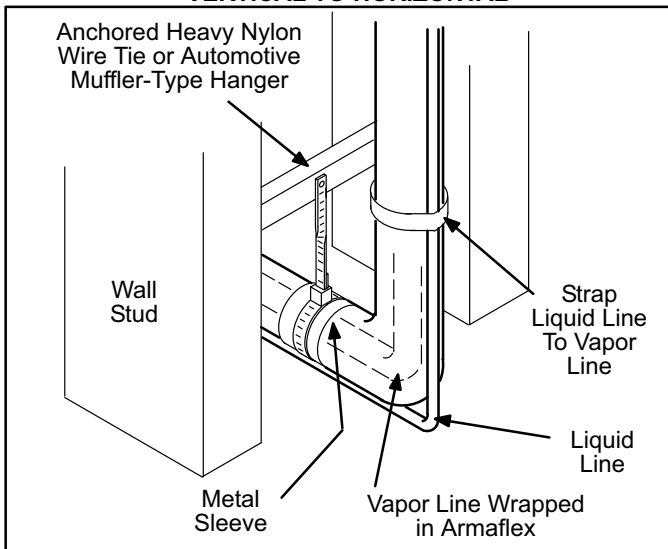

FIGURE 19

OUTSIDE UNIT PLACEMENT AND INSTALLATION

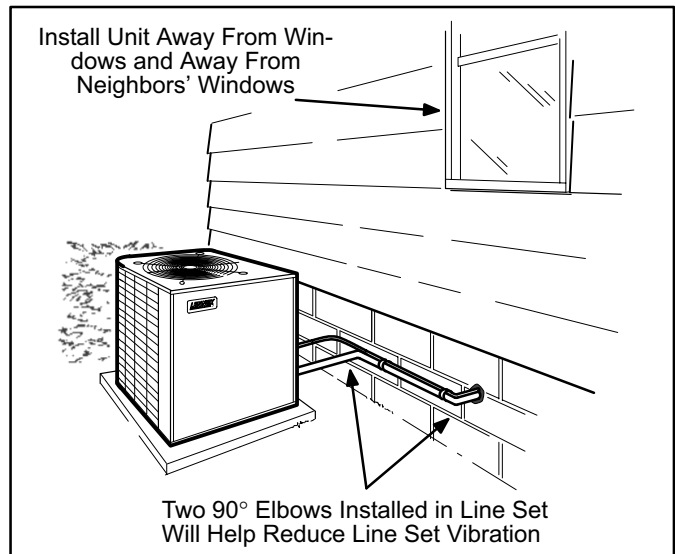
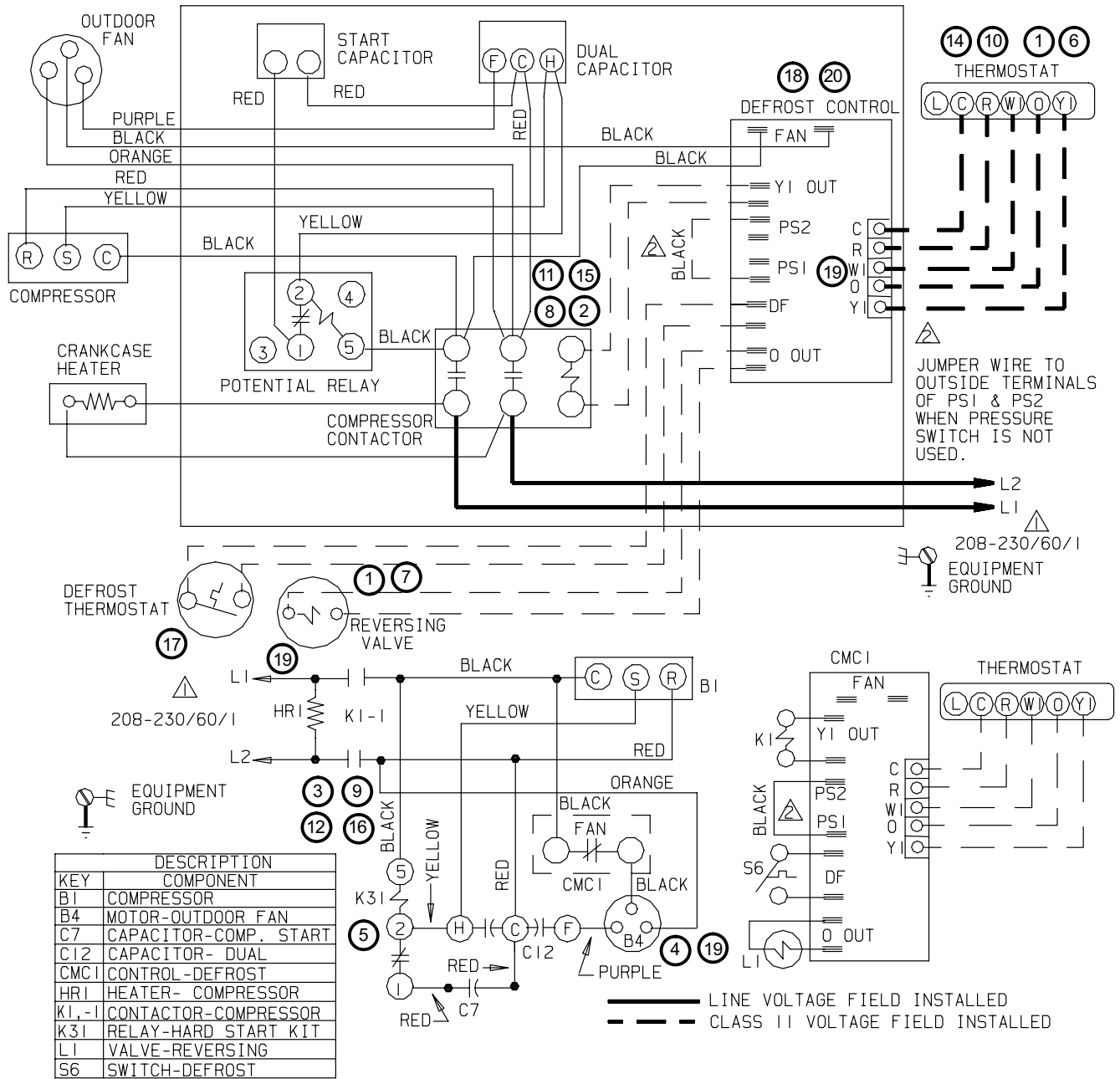

FIGURE 20

VII - WIRING DIAGRAMS AND SEQUENCE OF OPERATION

HP29 SINGLE-PHASE WITH RECIPROCATING COMPRESSOR HP29-1 / -2 UNITS



HP29 SINGLE-PHASE WITH RECIPROCATING COMPRESSOR

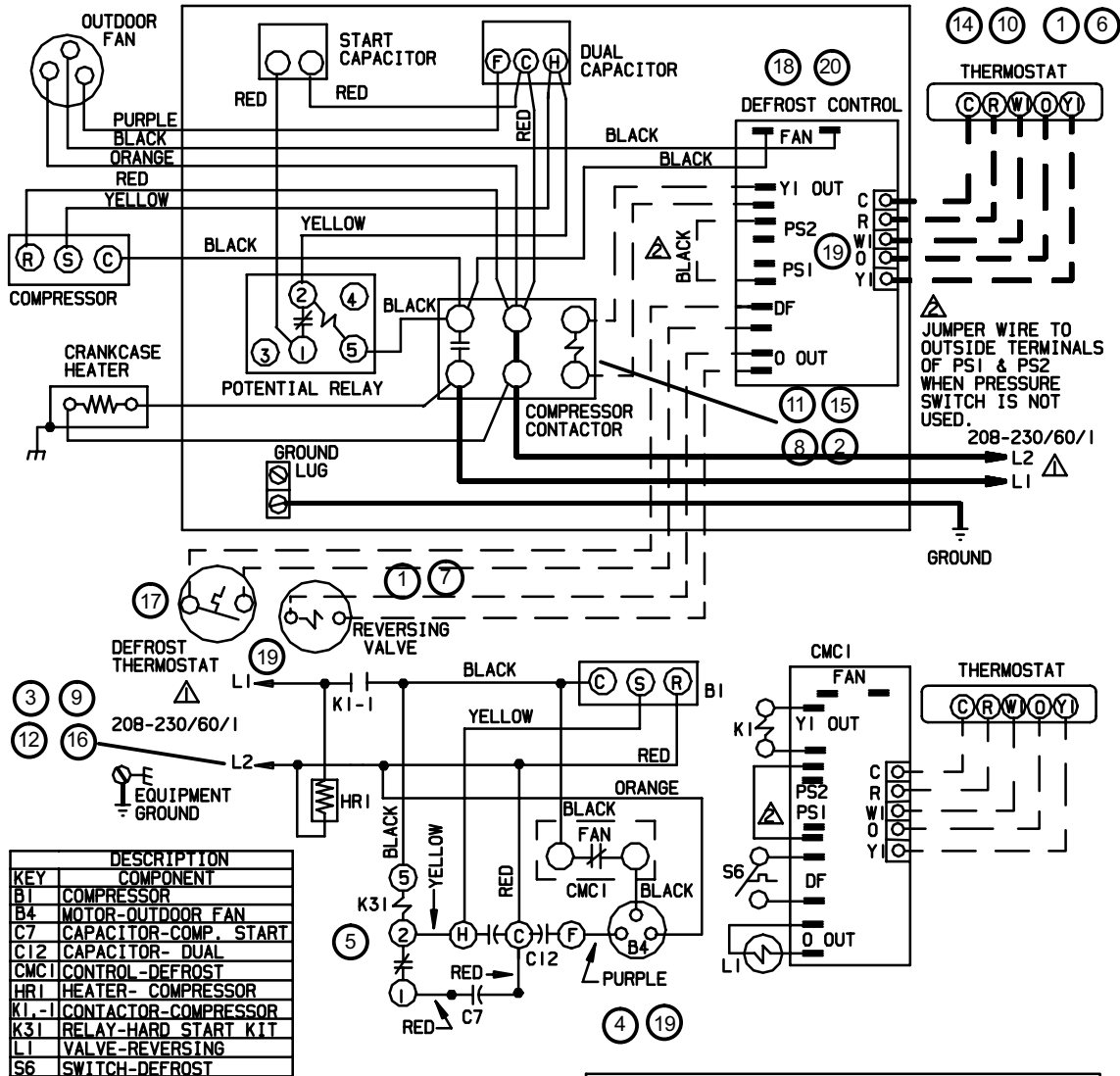

LENNOX® HEAT PUMP-OUTDOOR	
HP29-018-3-P HP29-024-3-P	
0801	Supersedes 533,312W
New Form No. 533,830W	

©2001 Lennox Industries Inc.

Litho U.S.A.

HP29 SINGLE-PHASE WITH RECIPROCATING COMPRESSOR

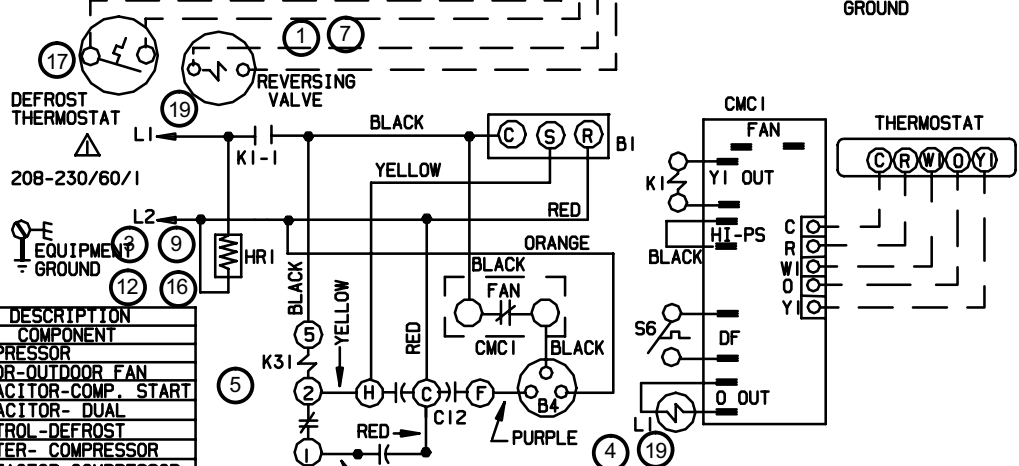
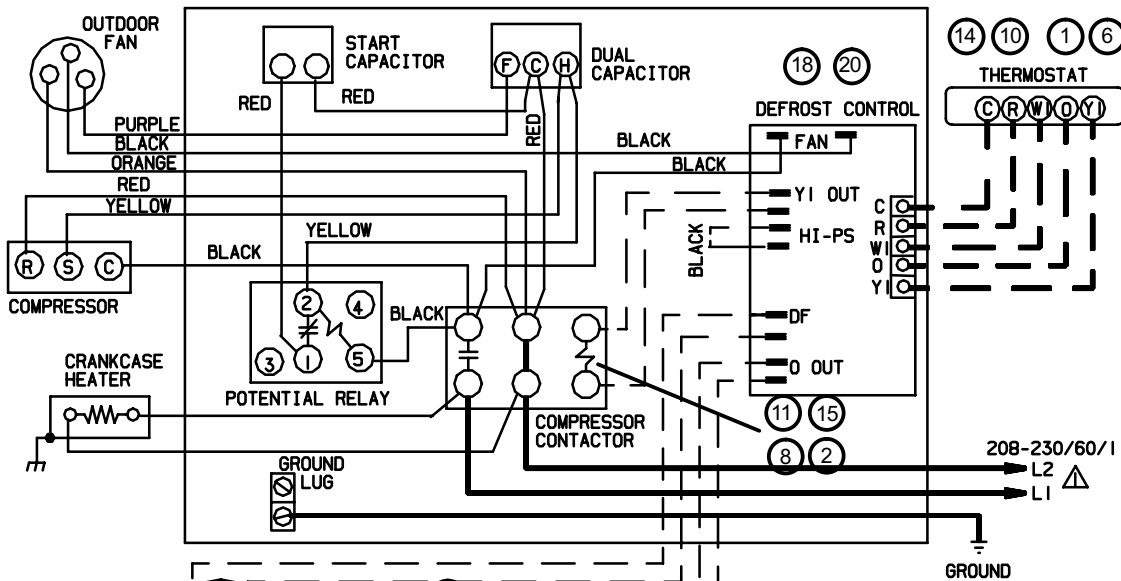

KEY	DESCRIPTION
B1	COMPRESSOR
B4	MOTOR-OUTDOOR FAN
C7	CAPACITOR-COMP. START
C12	CAPACITOR- DUAL
CMC1	CONTROL-DEFROST
HR1	HEATER- COMPRESSOR
K1-1	CONTACTOR-COMPRESSOR
K31	RELAY-HARD START KIT
L1	VALVE-REVERSING
S6	SWITCH-DEFROST

NOTE-
 △ FOR USE WITH COPPER CONDUCTORS ONLY. REFER TO UNIT RATING PLATE FOR MINIMUM CIRCUIT AMPACITY AND MAXIMUM OVER-CURRENT PROTECTION SIZE

WARNING-
 ELECTRIC SHOCK HAZARD, CAN CAUSE INJURY OR DEATH. UNIT MUST BE GROUND IN ACCORDANCE WITH NATIONAL AND LOCAL CODES.

— LINE VOLTAGE FIELD INSTALLED
 - - - CLASS II VOLTAGE FIELD INSTALLED

LENNOX® HEAT PUMP-OUTDOOR

HP29-018-4P
 HP29-024-4P

	Supersedes
1201	533, 830W
	New Form No.
	533, 920W

©2001 Lennox Industries Inc.

Litho U.S.A.

HP29 SINGLE-PHASE WITH SCROLL COMPRESSOR HP29-1 / -2 UNITS

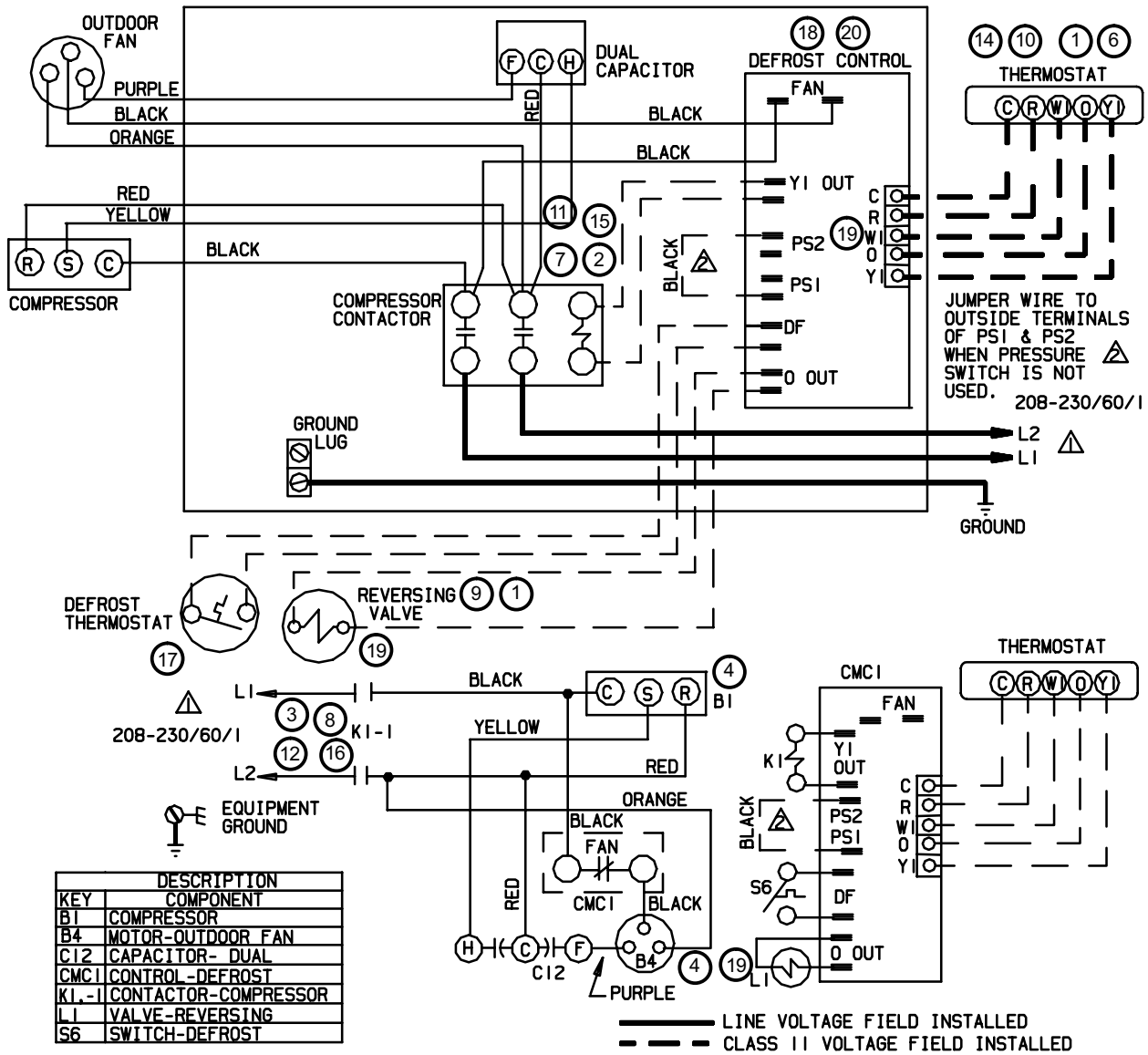

HP29 SINGLE-PHASE WITH SCROLL COMPRESSOR

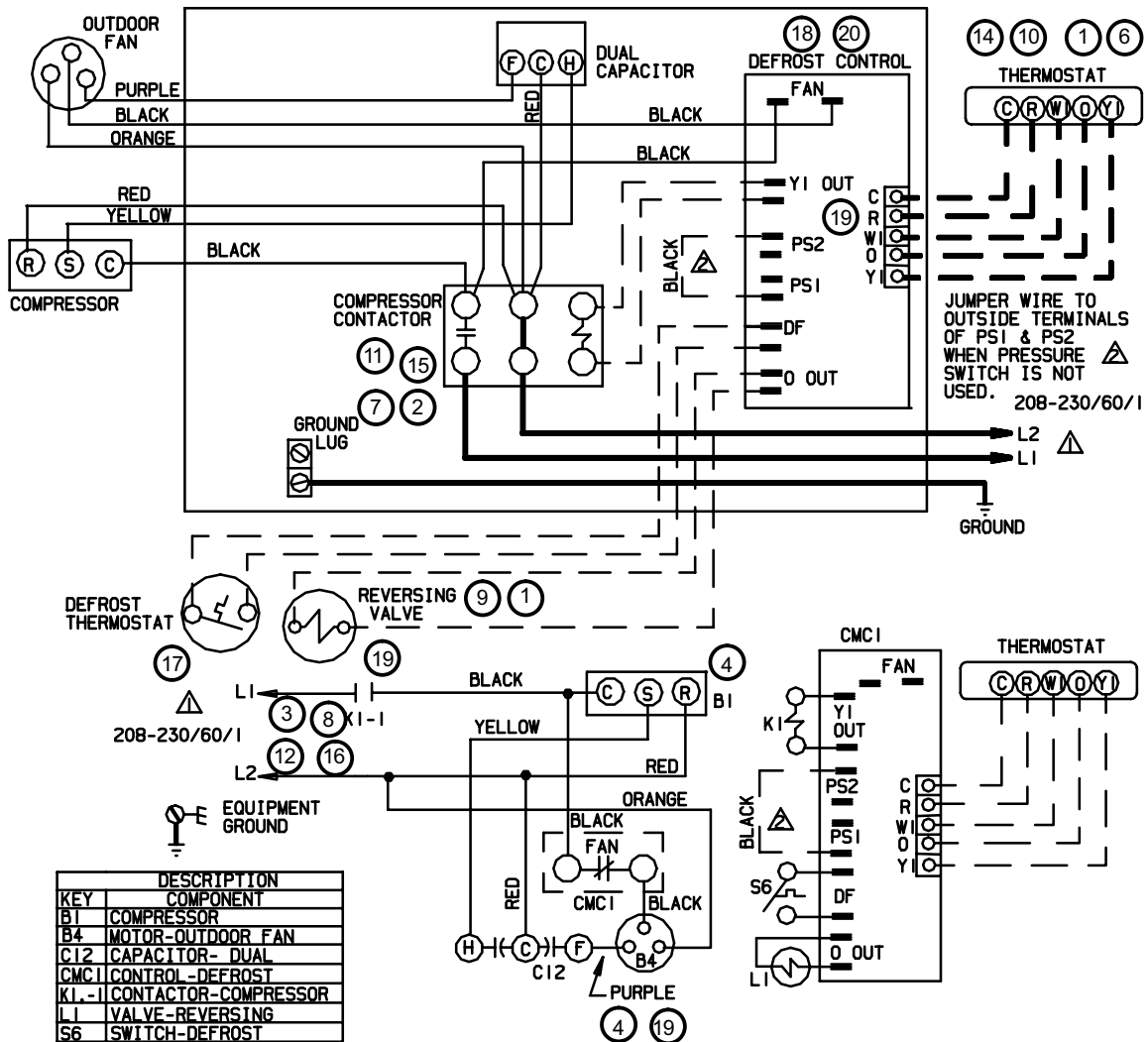

HP29 SINGLE-PHASE WITH SCROLL COMPRESSOR

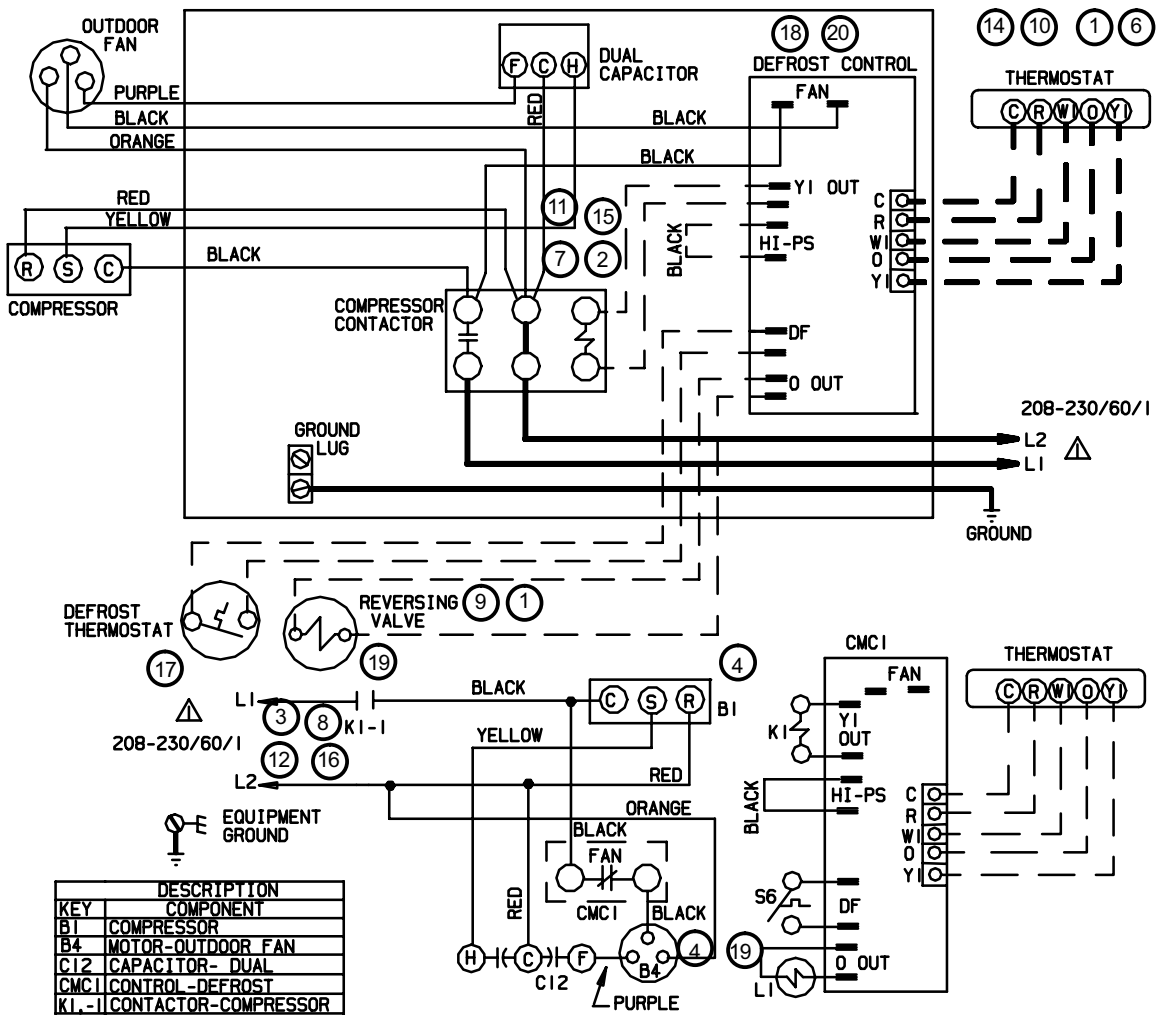

KEY	DESCRIPTION
B1	COMPRESSOR
B4	MOTOR-OUTDOOR FAN
C12	CAPACITOR- DUAL
CMC I	CONTROL-DEFROST
K1-I	CONTACTOR-COMPRESSOR
L1	VALVE-REVERSING
S6	SWITCH-DEFROST

▲ NOTE-
 FOR USE WITH COPPER CONDUCTORS
 ONLY. REFER TO UNIT RATING
 PLATE FOR MINIMUM CIRCUIT
 AMPACITY AND MAXIMUM OVER-
 CURRENT PROTECTION SIZE

WARNING-
 ELECTRIC SHOCK HAZARD, CAN CAUSE INJURY OR
 DEATH. UNIT MUST BE GROUND IN ACCORDANCE
 WITH NATIONAL AND LOCAL CODES.

——— LINE VOLTAGE FIELD INSTALLED
 - - - CLASS II VOLTAGE FIELD INSTALLED

LENNOX® HEAT PUMP-OUTDOOR	
HP29-030-4P	HP29-048-5P
HP29-036-4P	HP29-060-4P
HP29-042-4P	
	Supersedes
	1201 533,833W
	New Form No.
	533,923W

©2001 Lennox Industries Inc.

Litho U.S.A.

HP29 SINGLE-PHASE OPERATING SEQUENCE

a-HP29 P Voltage Operation Sequence

This is the sequence of operation for HP29 "P" voltage units. **This sequence applies to HP29 models equipped with either a reciprocating, or scroll compressor.** The sequence is outlined by numbered steps which correspond to circled numbers on the adjacent diagram.

NOTE- The thermostat used may be electromechanical or electronic.

NOTE- Transformer in indoor unit supplies power (24 VAC) to the thermostat and outdoor unit controls.

COOLING:

- 1 - Internal thermostat wiring energizes terminal O by cooling mode selection, energizing the reversing valve L1. Cooling demand initiates at Y1 in the thermostat.
- 2 - 24VAC energizes compressor contactor K1.
- 3 - K1-1 N.O. closes energizing terminal "C" of compressor (B1) and outdoor fan motor (B4).
- 4 - Outdoor fan motor (B4) begins immediate operation. **Scroll** compressor (B1) begins immediate operation.
- 5 - **Reciprocating** compressor (B1) begins start-up. Hard start contactor K31 remains closed during start-up and start capacitor C7 remains in the circuit. As the compressor gains speed, K31 is energized. When K31 is energized, the contacts open and start capacitor C7 is taken out of the circuit.

END OF COOLING DEMAND:

- 6 - Cooling demand is satisfied. Terminal Y1 is de-energized.
- 7 - Compressor contactor K1 is de-energized.
- 8 - K1-1 opens and compressor (B1) and outdoor fan motor (B4) are de-energized and stop immediately.
- 9 - Terminal O is de-energized when internal thermostat is out of cooling mode, de-energizing reversing valve L1.

FIRST STAGE HEAT:

- 10 - Heating demand initiates at Y1.
- 11 - 24VAC energizes compressor contactor K1.
- 12 - K1-1 N.O. closes energizing compressor and outdoor fan motor.
- 13 - See step 4 or 5.

END OF FIRST STAGE HEAT:

- 14 - Heating demand is satisfied. Terminal Y1 is de-energized.
- 15 - Compressor contactor K1 is de-energized.
- 16 - K1-1 opens and compressor (B1) and outdoor fan motor (B4) are de-energized and stop immediately.

DEFROST MODE:

- 17 - During heating operation when outdoor coil temperature drops below 35°F (2°C) or 42°F (5.5°C) (see defrost system description for specific unit dash number) unit defrost switch (thermostat) S6 closes.
- 18 - Defrost control CMC1 begins timing. If defrost thermostat (S6) remains closed at the end of the 30,60 or 90 minute period, defrost relay energizes and defrost begins.
- 19 - During defrost CMC1 energizes the reversing valve and W1 on the terminal strip (operating indoor unit on the first stage heat mode), while de-energizing outdoor fan motor B4.
- 20 - Defrost continues 14 ± 1 minutes or until thermostat switch (S6) opens. When defrost thermostat opens, defrost control timer loses power and resets.
- 21 - When CMC1 resets, the reversing valve and W1 on the terminal strip are de-energized, while the outdoor fan motor B4 is energized.

HP29 THREE-PHASE WITH RECIPROCATING OR SCROLL COMPRESSOR HP29-1/-2

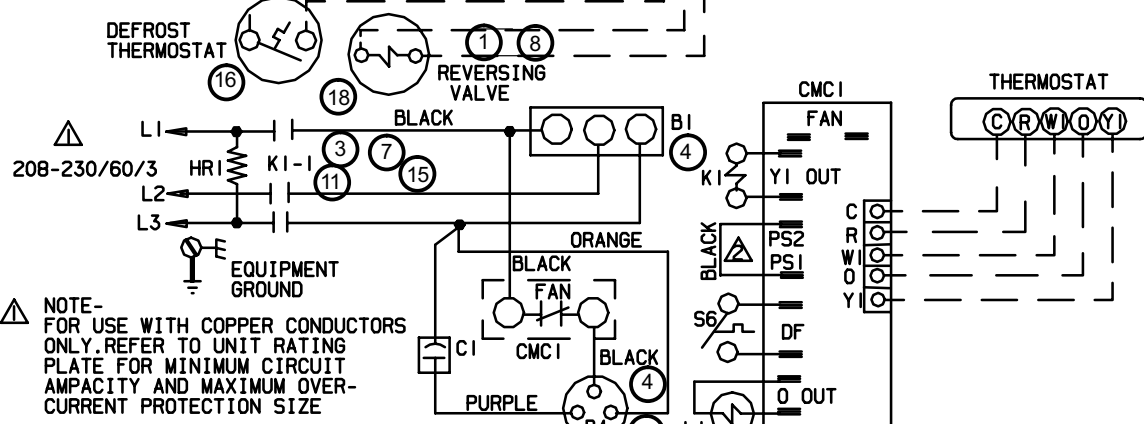
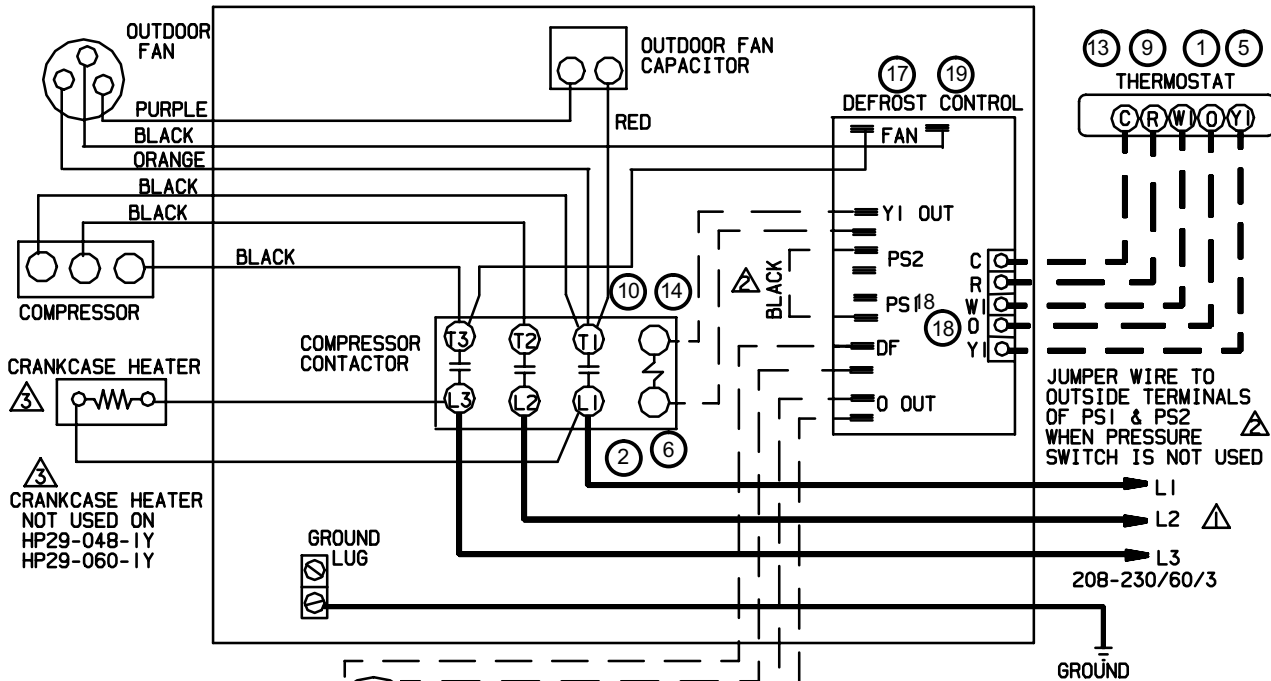

NOTE-
FOR USE WITH COPPER CONDUCTORS
ONLY. REFER TO UNIT RATING
PLATE FOR MINIMUM CIRCUIT
AMPACITY AND MAXIMUM OVER-
CURRENT PROTECTION SIZE

KEY	DESCRIPTION
B1	COMPRESSOR
B4	MOTOR-OUTDOOR FAN
C1	CAPACITOR-OUTDOOR FAN
CMC1	CONTROL-DEFROST
HRI	HEATER-COMPRESSOR
K1-1	CONTACTOR-COMPRESSOR
L1	VALVE-REVERSING
S6	SWITCH-DEFROST

— LINE VOLTAGE FIELD INSTALLED
- - CLASS II VOLTAGE FIELD INSTALLED

WARNING-
ELECTRIC SHOCK HAZARD, CAN CAUSE INJURY OR
DEATH. UNIT MUST BE GROUND IN ACCORDANCE
WITH NATIONAL AND LOCAL CODES.

NOTE-Scroll three-phase compressors must be phased correctly. Compressor noise may be significantly higher indicating phasing is incorrect. Compressor operating backwards will not provide cooling. Continued backard operation will cause compressor to cylce on internal protector.

HP29 THREE-PHASE WITH RECIPROCATING OR SCROLL COMPRESSOR

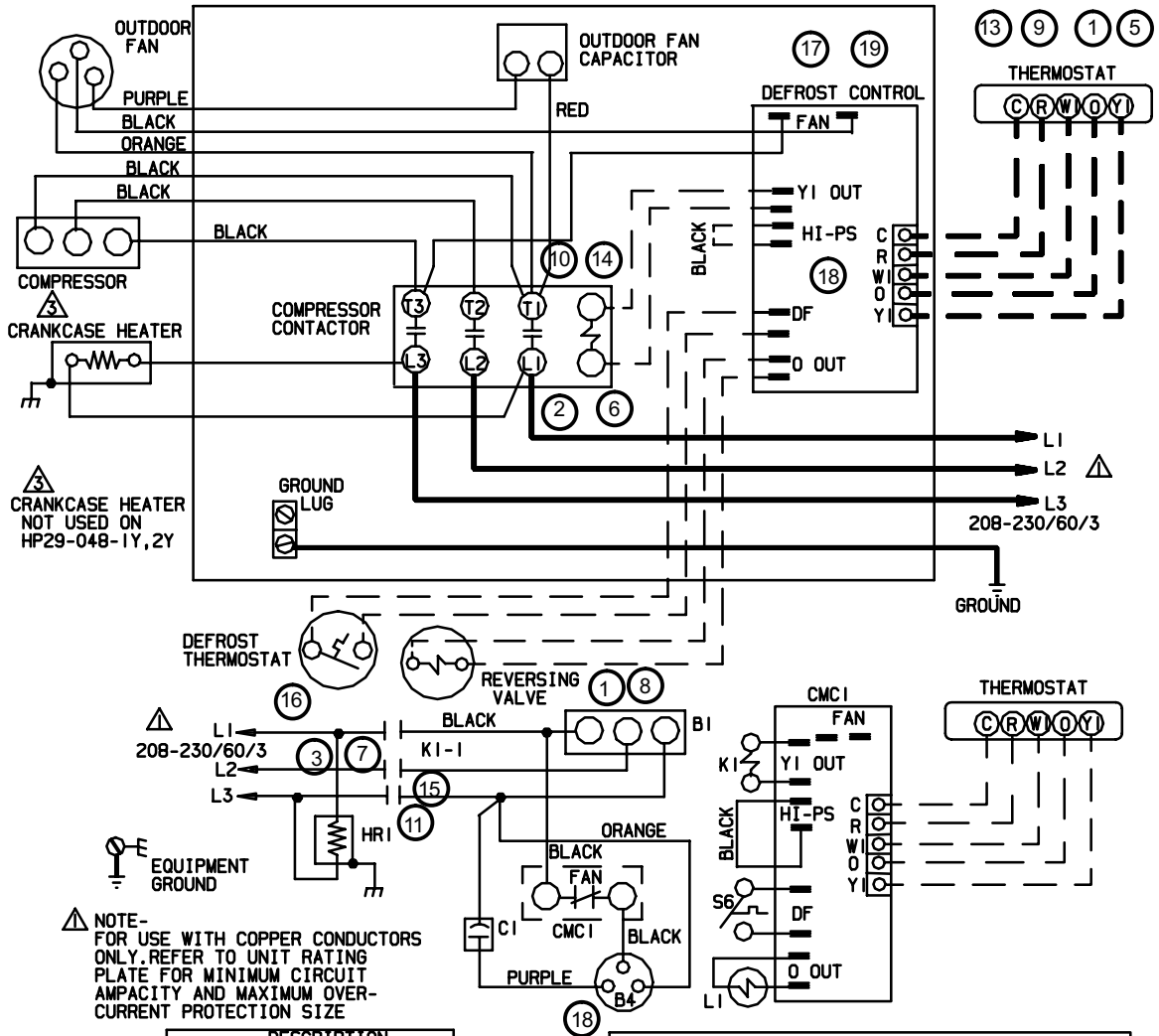

KEY	DESCRIPTION
	COMPONENT
B1	COMPRESSOR
B4	MOTOR-OUTDOOR FAN
C1	CAPACITOR-OUTDOOR FAN
CMCI	CONTROL-DEFROST
HRI	HEATER-COMPRESSOR
K1-1	CONTACTOR-COMPRESSOR
L1	VALVE-REVERSING
S6	SWITCH-DEFROST

WARNING-
ELECTRIC SHOCK HAZARD, CAN CAUSE INJURY OR DEATH. UNIT MUST BE GROUND IN ACCORDANCE WITH NATIONAL AND LOCAL CODES.

— LINE VOLTAGE FIELD INSTALLED
 - - CLASS II VOLTAGE FIELD INSTALLED

LENNOX® HEAT PUMP-OUTDOOR	
HP29-036-3Y HP29-042-3Y HP29-048-4Y HP29-060-3Y	
Supersedes	1201 533,317W
New Form No. 533,913W	

©2001 Lennox Industries Inc.

Litho U.S.A.

HP29 THREE-PHASE OPERATING SEQUENCE

a-HP29 "Y", "G", and "J" Voltage Operation Sequence

This is the sequence of operation for HP29 "Y" voltage. HP29 "G" and "J" voltage units are similar, but have a few additions. The "G" voltage units have an outdoor fan relay, while the "J" voltage units have the outdoor fan relay plus an outdoor fan transformer. The "Y" voltage unit sequence is outlined by numbered steps which correspond to circled numbers on the adjacent diagram.

NOTE- The thermostat used may be electromechanical or electronic.

NOTE- Transformer in indoor unit supplies power (24 VAC) to the thermostat and outdoor unit controls.

COOLING:

- 1 - Internal thermostat wiring energizes terminal O by cooling mode selection, energizing the reversing valve L1. Cooling demand initiates at Y1 in the thermostat.
- 2 - 24VAC energizes compressor contactor K1.
- 3 - K1-1 N.O. closes energizing compressor (B1) and outdoor fan motor (B4).
- 4 - Compressor (B1) and outdoor fan motor (B4) begin immediate operation.

END OF COOLING DEMAND:

- 5 - Cooling demand is satisfied. Terminal Y1 is de-energized.
- 6 - Compressor contactor K1 is de-energized.
- 7 - K1-1 opens and compressor (B1) and outdoor fan motor (B4) are de-energized and stop immediately.
- 8 - Terminal O is de-energized when internal thermostat wiring is out of cooling mode, de-energizing reversing valve L1.

FIRST STAGE HEAT:

- 9 - Heating demand initiates at Y1.
- 10 - 24VAC energizes compressor contactor K1.
- 11 - K1-1 N.O. closes energizing compressor and outdoor fan motor.
- 12 - See step 4.

END OF FIRST STAGE HEAT:

- 13 - Heating demand is satisfied. Terminal Y1 is de-energized.
- 14 - Compressor contactor K1 is de-energized.
- 15 - K1-1 opens and compressor (B1) and outdoor fan motor (B4) are de-energized and stop immediately.

DEFROST MODE:

- 16 - During heating operation when outdoor coil temperature drops below 35°F (2°C) or 42°(5.5°C) (see defrost system description for specific unit dash number) unit defrost switch (thermostat) S6 closes.
- 17 - Defrost control CMC1 begins timing. If defrost thermostat (S6) remains closed at the end of the 30,60 or 90 minute period, defrost relay energizes and defrost begins.
- 18 - During defrost CMC1 energizes the reversing valve and W1 on the terminal strip (operating indoor unit on the first stage heat mode), while de-energizing outdoor fan motor B4.
- 19 - Defrost continues 14 ± 1 minutes or until thermostat switch (S6) opens. When defrost thermostat opens, defrost control timer loses power and resets.
- 20 - When CMC1 resets, the reversing valve and W1 on the terminal strip are de-energized, while the outdoor fan motor B4 is energized.