

LENNOX®

PRODUCT LITERATURE

©1999 Lennox Industries Inc.
Dallas, Texas

503,877M
02/99
Supersedes 9/98

USER'S INFORMATION MANUAL

G24M SERIES 50HZ GAS FURNACE

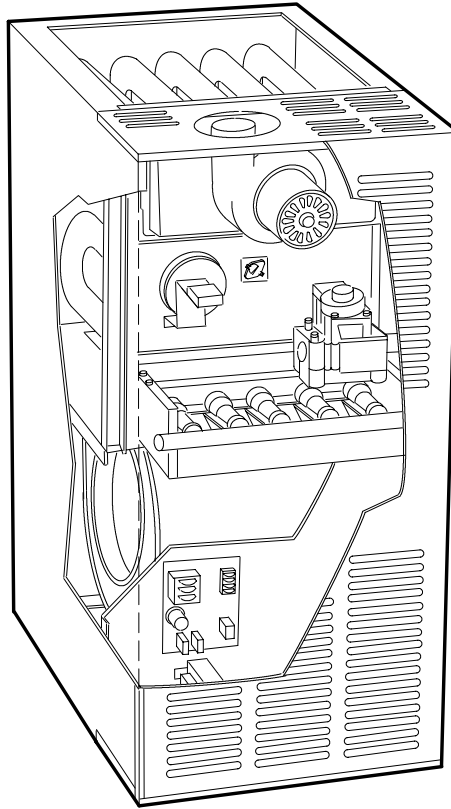

**RETAIN THESE INSTRUCTIONS
FOR FUTURE REFERENCE**

TTL Technical
Literature

Litho USA

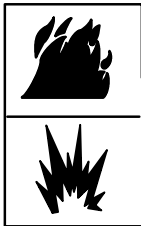

⚠ WARNING

If the information in this manual is not followed exactly, a fire or explosion may result causing property damage, personal injury or loss of life.



Do not store or use gasoline or other flammable vapors and liquids in the vicinity of this or any other appliance.

Installation and service must be performed by a qualified installer, service agency or the gas supplier.

WHAT TO DO IF YOU SMELL GAS:

- **Do not try to light any appliance.**
- **Extinguish any open flames.**
- **Do not touch any electrical switch; do not use any phone in your building.**
- **Immediately call your gas supplier from a neighbor's phone. Follow the gas supplier's instructions.**
- **If you cannot reach your gas supplier, call the fire department.**

G24M PARTS IDENTIFICATION

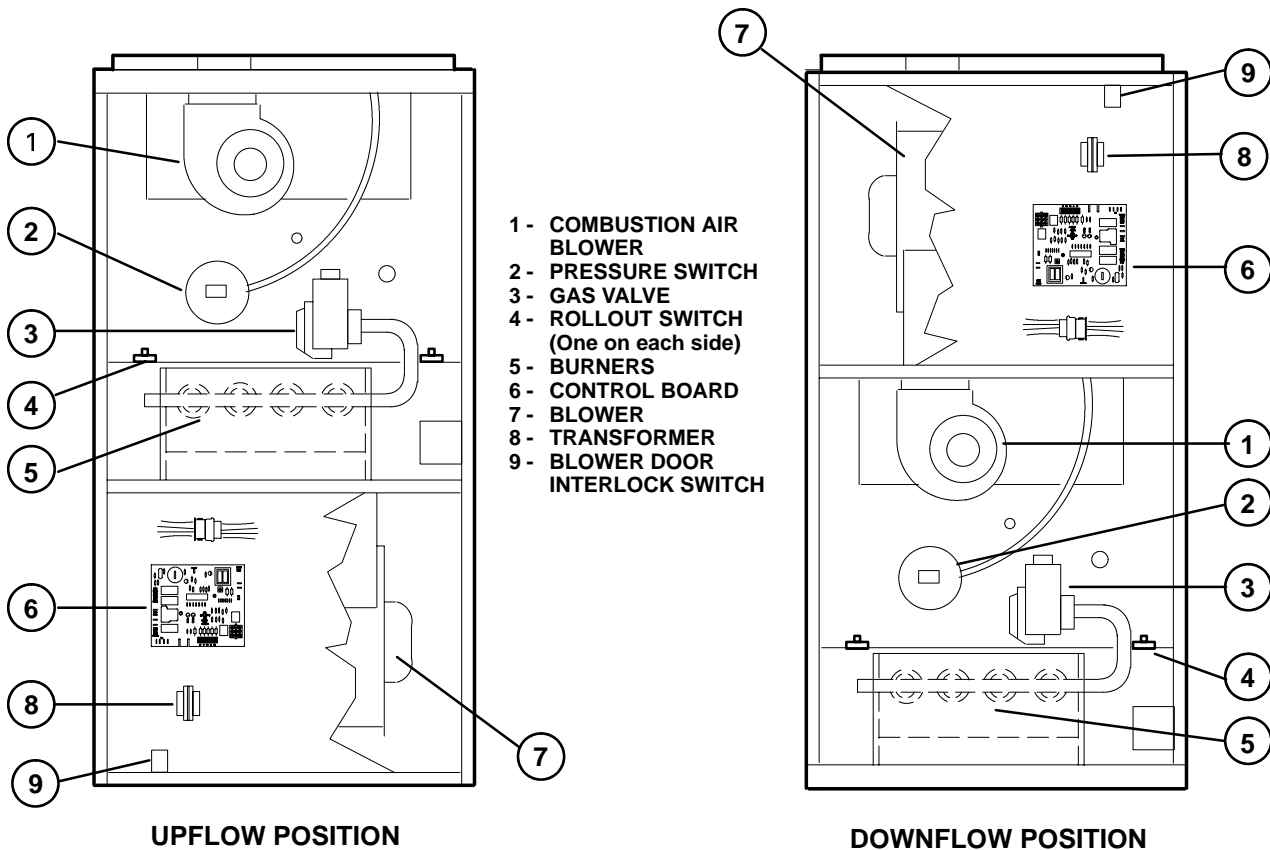

⚠ WARNING

Product contains fiberglass wool. Disturbing the insulation in this product during installation, maintenance, or repair will expose you to fiberglass wool. Breathing this may cause lung cancer. (Fiberglass wool is known to the State of California to cause cancer.) Fiberglass wool may also cause respiratory, skin, and eye irritation. To reduce exposure to this substance or for further information, consult material safety data sheets available from address shown below, or contact your supervisor.

Lennox Industries Inc.
P.O. Box 799900
Dallas, TX 75379-9900

⚠ WARNING

If overheating occurs or if gas supply fails to shut off, shut off the manual gas valve to the appliance before shutting off electrical supply.

⚠ WARNING

Do not use this furnace if any part has been under water. Immediately call a qualified service technician to inspect the furnace and to replace any part of the control system and any gas control which has been under water.

⚠ CAUTION

Before attempting to perform any service or maintenance, turn the electrical power to unit OFF at disconnect switch.

⚠ IMPORTANT

Any additions, changes, or conversions required in order for the appliance to satisfactorily meet the application needs must be made by a Lennox service technician using factory specified and approved parts.

Important Directions

- 1 - Keep the furnace area clear and free of combustible material, gasoline, and other flammable vapors and liquids. If installed in an insulated area, furnace must be kept free of insulating material. Insulating material may be combustible. Inspect furnace venting system to make sure it is in place, physically sound, and without holes, corrosion, or blockage. Inspect furnace return air duct connection to ensure duct is sealed to the furnace and terminates outside the space containing the furnace. Inspect the physical support of the furnace to guarantee that it is sound without sagging, cracks or gaps around base and it maintains seal between base and support.
- 2 - DO NOT obstruct air flow to unit. Unit must receive an unobstructed flow of combustion and ventilating air.
- 3 - DO NOT store chlorine or fluorine products near unit or introduce these products into the combustion air. These products can cause furnace corrosion.
- 4- **DO NOT draw return air from a room where this furnace, or any other gas appliance (ie., a water heater), is installed.** When return air is drawn from a room, a negative pressure is created in the room. If a gas appliance is operating in a room with negative pressure, the flue products can be pulled back down the vent pipe and into the room. This reverse flow of the flue gas may result in incomplete combustion and the formation of carbon monoxide gas. This toxic gas might then be distributed throughout the house by the furnace duct system.

Your furnace is a gas appliance. It is critical that the gas supplied to the unit be completely burned to avoid the production of carbon monoxide gas. Complete combustion of the gas requires, but is not limited to, correct gas pressure and gas flow rate, adequate combustion, air, and proper venting.

WARNING

Carbon monoxide gas is invisible, odorless, and toxic.

Exposure to this gas can cause personal injury and even death to all occupants, including pets. Any item that is powered by or gives off heat from a combustion process

(including lawn mowers, automobiles, and fireplaces) has the potential to produce carbon monoxide gas. Because of this, **Lennox recommends the use of a carbon monoxide detector in your home, even if you do not own gas appliances.** Reliable detectors are available at reasonable retail prices. Contact your independent Lennox dealer for more details about this investment in your safety.

Your furnace is designed to meet standards set by national agencies, and to operate safely when properly installed and maintained. However, the unit's performance can be greatly impacted by the individual installation and the operating environment. It is your responsibility to ensure that this appliance is maintained. Proper maintenance is critical for your safety and the satisfactory operation of the product. **Lennox strongly recommends annual inspection and maintenance of this appliance.** Contact your independent Lennox dealer for an inspection by a qualified service technician.

Your furnace is designed to meet standards set by national agencies, and to operate safely when properly installed and maintained. However, the unit's performance can be greatly impacted by the individual installation and the operating environment. It is your responsibility to ensure that this appliance is maintained. Proper maintenance is critical for your safety and the satisfactory operation of the product. **Lennox strongly recommends annual inspection and maintenance of this appliance.** Contact your independent Lennox dealer for an inspection by a qualified service technician.

Lighting Information and Operation

WARNING

If you do not follow these instructions exactly, a fire or explosion may result causing property damage, personal injury or loss of life.

BEFORE LIGHTING smell all around the appliance area for gas. Be sure to smell next to the floor because some gas is heavier than air and will settle on the floor.

Placing Furnace Into Operation

G24M units are equipped with an electronic ignition system. Do not attempt to manually light burners on these furnaces. Each time the thermostat calls for heat, the burner will automatically light.

Use only your hand to turn the gas control knob. Never use tools. If the knob will not turn by hand, do not try to repair it, call a qualified service technician. Force or attempted repair may result in a fire or explosion.

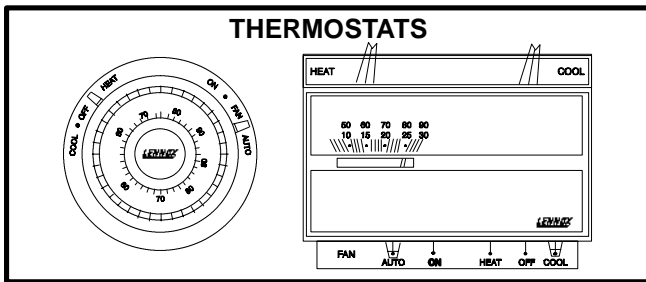

FIGURE 1

Gas Valve Operation

- 1 - **STOP!** Read the safety information at the beginning of this section.
- 2 - Set the thermostat to lowest setting. See figure 1.
- 3 - Turn off all electrical power to the unit.
- 4 - This furnace is equipped with an ignition device which automatically lights the burner. Do **not** try to light the burner by hand.
- 5 - Remove the access panel.
- 6 - *White Rodgers 36E Gas Valve* - Turn knob on gas valve 180° either way to **OFF**. See figure 2.
Honeywell VR8205 Gas Valve - Turn knob on gas valve clockwise to **OFF**. Do not force. See figure 3.
- 7 - Wait five (5) minutes to clear out any gas. If you then smell gas, **STOP!** Immediately call your gas supplier from a neighbor's phone. Follow the gas supplier's instructions. If you do not smell gas go to next step.

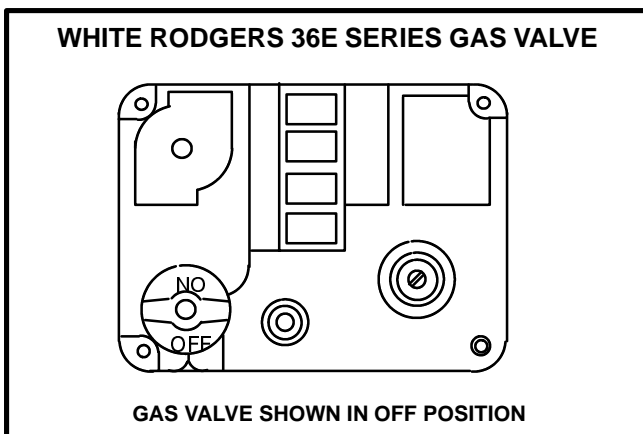

FIGURE 2

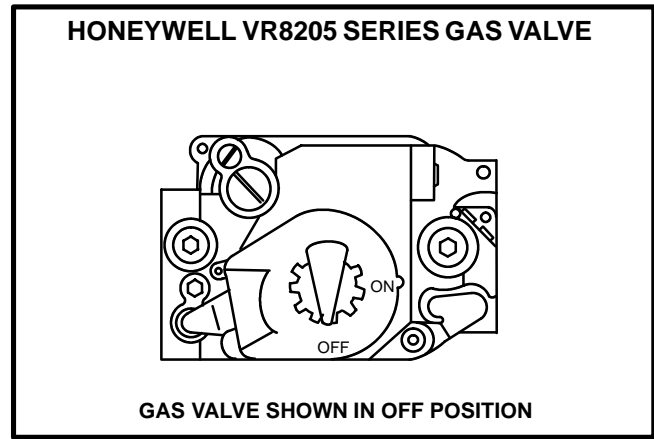

FIGURE 3

- 8 - *White Rodgers 36E Gas Valve* - Turn knob on gas valve 180° either way to **ON**.
Honeywell VR8205 Gas Valve - Turn knob on gas valve counterclockwise to **ON**. Do not force.
- 9 - Replace the access panel.
- 10 - Turn on all electrical power to unit.
- 11 - Set the thermostat to desired setting.
NOTE-When unit is initially started, steps 1 through 11 may need to be repeated to purge air from gas line.
- 12 - If the appliance will not operate, follow the instructions "Turning Off Gas to Unit" and call your service technician or gas supplier.

Turning Off Gas to Unit

- 1 - Set the thermostat to the lowest setting.
- 2 - Turn off all electrical power to the unit if service is to be performed.
- 3 - Remove the access panel.
- 4 - Turn knob on White Rodgers gas valve 180° either way to **OFF**; turn knob on Honeywell valve clockwise to **OFF**. Do not force.
- 5 - Replace the access panel.

Filters

G24M series units are equipped with external filters which should be inspected monthly and replaced when necessary to assure proper furnace operation. See table 1 for filter sizes. Replacement filters used with G24M-40/60/75 units must have a minimum velocity rating of 400 FPM. Replacement filters used with G24M-100/120/140 units require a minimum velocity rating of 625 FPM. Figures 4, 5 and 6 show possible filter locations.

TABLE 1

MODEL NUMBER	FILTER SIZE	
	UPFLOW	DOWNFLOW
	1 FILTER	2 FILTERS
G24M-45/60/75	16 in. X 20 in. X 1 in.	16 in. X 20 in. X 1 in.
G24M-100/120/140	20 in. X 20 in. X 1 in.	16 in. X 20 in. X 1 in.

**UPFLOW FURNACE
BOTTOM RETURN AIR**

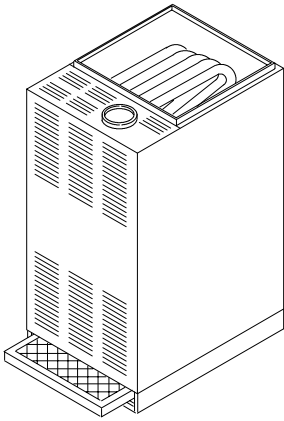

FIGURE 4

**UPFLOW FURNACE
SIDE RETURN AIR**

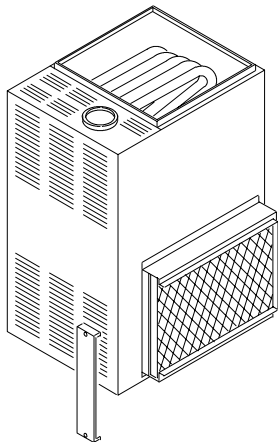

FIGURE 5

**DOWNFLOW FURNACE
FILTERS IN PLENUM RACK**

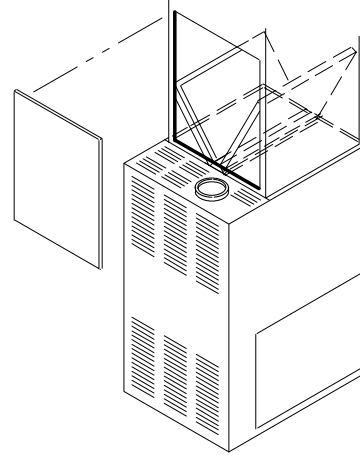

FIGURE 6

Blower

Check and clean blower wheel for any debris. Blower motor is prelubricated for extended bearing life. No further lubrication is needed.

⚠ WARNING

Blower door must be securely in place when blower and burners are operating. Gas fumes, which could contain carbon monoxide, can be drawn into living space resulting in personal injury or death.

Burner Flame

The G24M burner flame is not adjustable; however, the flame should be inspected at the beginning of each heating season and burners should be cleaned, if necessary. Burner flame should be blue when burning natural gas, blue/yellow when burning propane gas.

BURNER FLAME

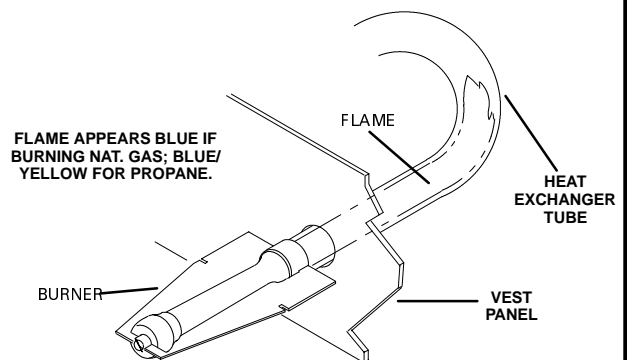

FIGURE 7

Venting System Inspection

Annually (before heating season) inspect furnace venting system, vent cap, heat exchanger and burners for corrosion, deterioration, or deposits of debris. Remove any obstructions.

Contact your Lennox dealer for a periodic unit inspection by a qualified service technician.

Flame Rollout Safety Switches

Your Lennox furnace is equipped with two flame roll-out safety switches which shut off the gas supply to the furnace in case of heat exchanger blockage. If the furnace fails to operate due to the functioning of these safety switches, DO NOT attempt to place the furnace into operation. Contact a qualified service technician.

Service Reminder

Call your Lennox service technician if unit is inoperative. Before calling, always check the following to be sure service is required.

- 1 - Check that electrical disconnect switches are **ON**.
- 2 - Check room thermostat for proper setting.
- 3 - Replace any blown fuses or reset circuit breakers.
- 4 - Gas valve should be **ON**.
- 5 - Air filter should not be plugged limiting air flow.
- 6 - Is gas turned on at meter?
- 7 - Is manual main shut-off valve open?

To keep your Lennox gas heating system in peak operating condition year after year, contact your independent Lennox dealer about a planned service program.

Safety Precautions

If you discover any of the following, shut down your unit, and contact an independent Lennox dealer for an inspection by a qualified technician.

- If you repeatedly hear any new or unfamiliar sounds while your unit is operating, there may be a problem. For example, poorly performing burners can produce unfamiliar noises.
- If you smell any unusual odors, your unit may be operating improperly. For example, units can give off unfamiliar odors if components are required to operate in abnormal conditions.
- Look for visible signs of a malfunctioning unit. Examples include unusual amounts of condensate on windows inside your house, visibly burnt components or unusual dirt or rust accumulations on the vent pipe or in the unit.

- If you experience headache, nausea, fatigue, or dizziness, the cause could be exposure to carbon monoxide gas. This is often misdiagnosed as the flu because symptoms are similar. If you suffer from flu-like symptoms that are exaggerated at home, but seem to subside while you are away from the house, exposure to carbon monoxide could be the cause.

Your vigilance may pay off in early detection of a problem before either personal injury or property damage occurs. Do not hesitate to contact a qualified service technician as an investment in your well being.

Planned Service

You should expect a service technician to check the following items during an annual inspection. Power to the unit must be shut off for the service technician's safety.

Fresh air grilles and louvers (on the unit and in the room where the furnace is installed) - Must be open and unobstructed to provide combustion air.

Burners- Must be inspected for rust, dirt, or signs of water.

Vent pipe - Must be inspected for signs of water, damaged or sagging pipe, or disconnected joints.

Unit appearance - Must be inspected for rust, dirt, signs of water, burnt or damaged wires, or components.

Fan access door - Must be properly in place and provide a seal between the return air and the room where the furnace is installed.

Return air duct - Must be properly attached and provide an air seal to unit.

Operating performance - Unit must be observed during operation to monitor proper performance of the unit and the vent system.

Combustion gases - Flue products must be analyzed and compared to the unit specifications.

Problems detected during the inspection may make it necessary to temporarily shut down the furnace until the items can be repaired or replaced.

Pay attention to your furnace. Situations can arise between annual furnace inspections that may result in unsafe operation. For instance, items innocently stored next to the furnace may obstruct the combustion air supply. This could cause incomplete combustion and the production of carbon monoxide gas.