

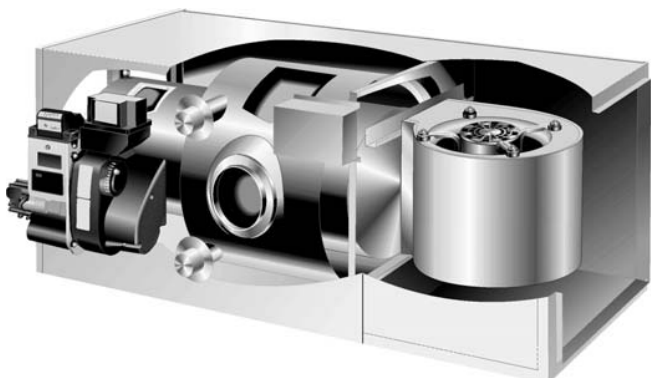

© 2002 Lennox Industries Inc.
Dallas, Texas, USA



INSTALLATION INSTRUCTIONS

OHR23 SERIES UNITS

OIL UNITS
504,628M
38152A061
06/04
Supersedes 4/02

TP Technical
Publications
Litho U.S.A.

General

These instructions are intended as a general guide and do not supersede local codes in any way. Only qualified technicians can install and service the Lennox Elite® Series OHR23 oil furnaces. In Canada, refer to CSA B139 for recommended installation procedures. Consult authorities who have jurisdiction before installation.

⚠ CAUTION
Never burn garbage or paper in the heating system.
Never leave papers near or around the unit.

Shipping & Packing List

- 1- Assembled oil furnace
- 1- Draft control

Check the components for shipping damage. If you find any damage, immediately contact the last carrier.

⚠ WARNING
Improper installation, adjustment, alteration, service, or maintenance can cause injury or property damage. Refer to this manual. For assistance or additional information, consult a qualified installer or service agency.

Table of Contents

General	1
Unit Dimensions	2
OHR23 Unit Parts Arrangement	3
Oil Burner Parts Arrangement	3
Requirements	4
Installation	5
Supply & Return Air Plenums	5
Optional Filter Kit	6
Initial Set-Up of Unit	6
Venting	7
Flue Connections	10
Oil Supply Lines Sizing	11
Oil Supply Line & Filter Connections	12
Leak Check	12
Electrical Wiring	13
Unit Start-Up & Adjustments	13
Service	14
Start-Up & Performance Checklist	15
Troubleshooting	16

**RETAIN THESE INSTRUCTIONS
FOR FUTURE REFERENCE**

⚠ CAUTION
Do not store or use gasoline or other flammable vapors and liquids in the vicinity of this or any other appliance.

⚠ CAUTION
When venting this appliance, keep vent terminal free of snow, ice and debris.



OHR23 Unit Dimensions - Inches (mm)

Model No.		A	B	C	D	E	F	G	H
OHR23Q3-105/120	in.	20-1/2	20-1/2	18	18	18	18	3	10-1/4
	mm	521	521	457	457	457	457	76	260
OHR23Q5-140/154	in.	23-1/2	23-1/2	21	21	21	21	4-3/4	11-3/8
	mm	597	597	533	533	533	533	121	289

HORIZONTAL POSITION

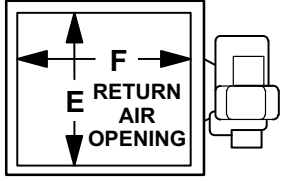
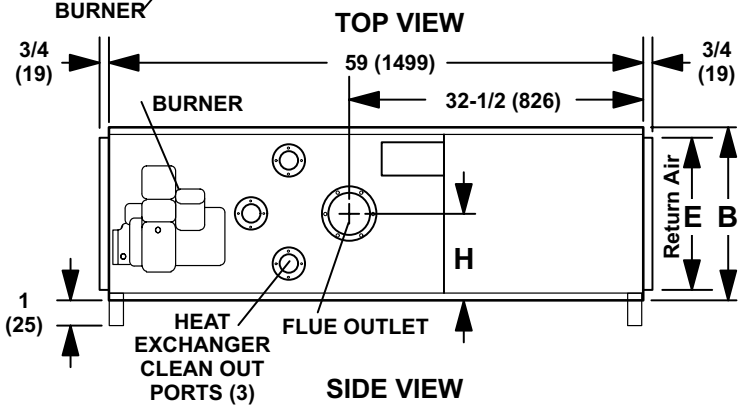
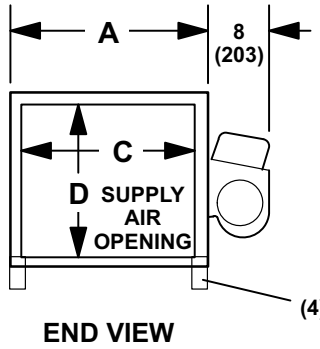
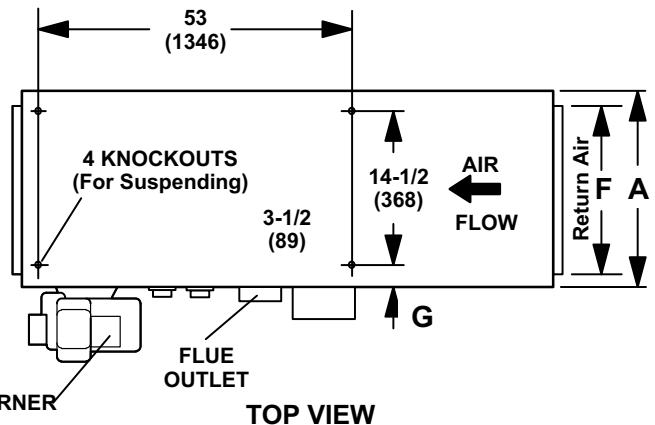

DOWNFLOW POSITION

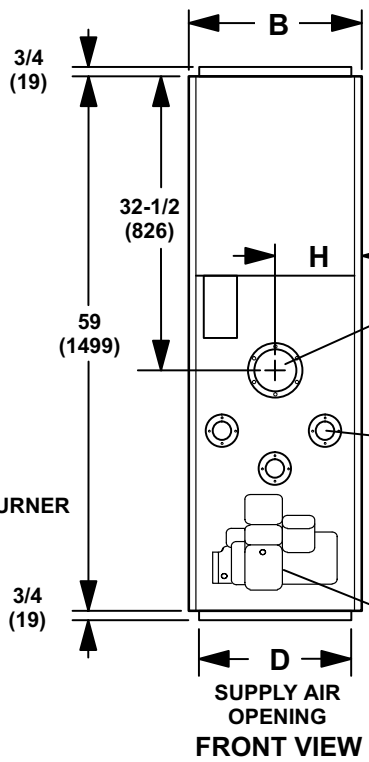
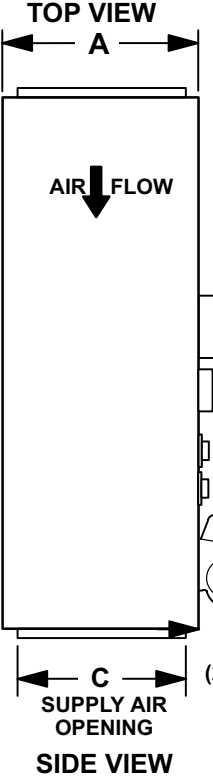

OPTIONAL DOWNFLOW COMBUSTIBLE FLOOR BASE

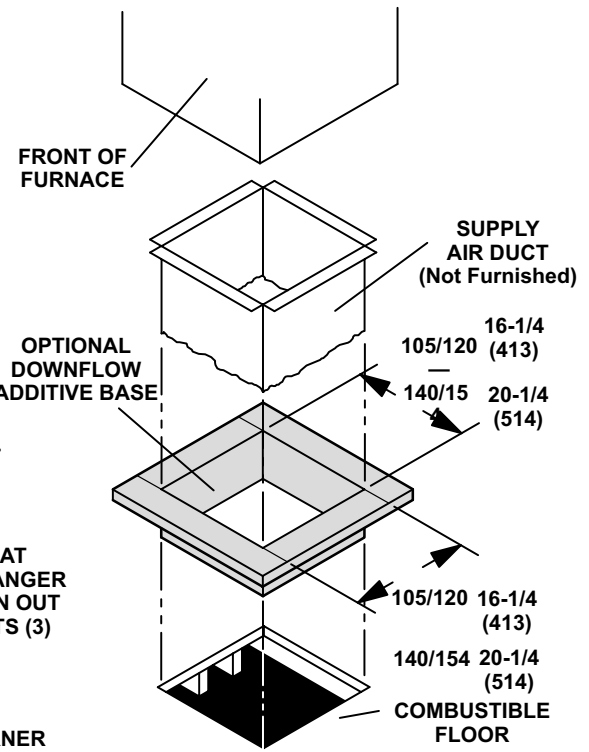

Additive Base Raises Furnace 3/4 in. (19 mm) Inch above Floor Level

OHR23 Unit Parts Arrangement

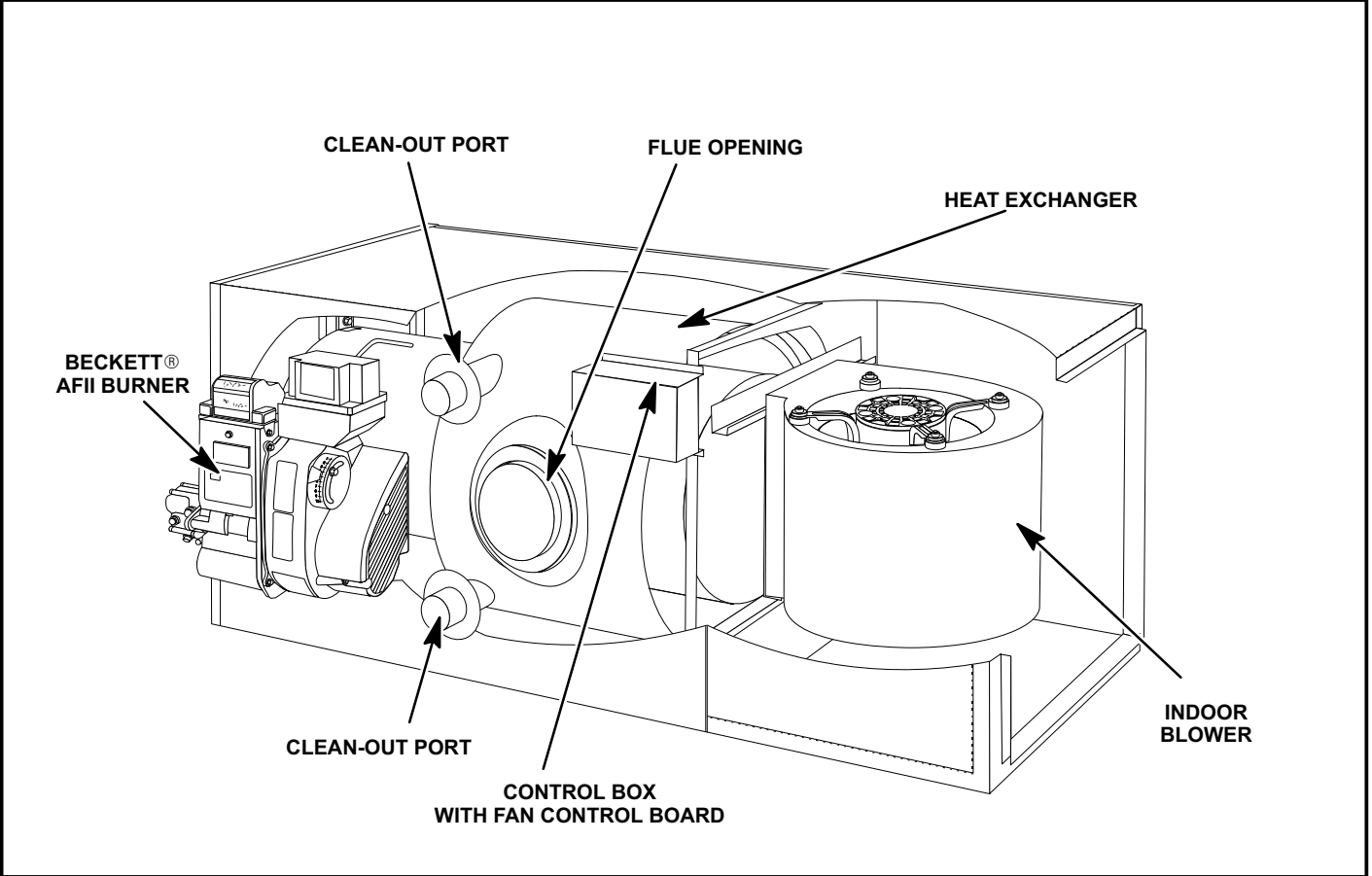

Figure 1

OHR23 Oil Burner Parts Arrangement

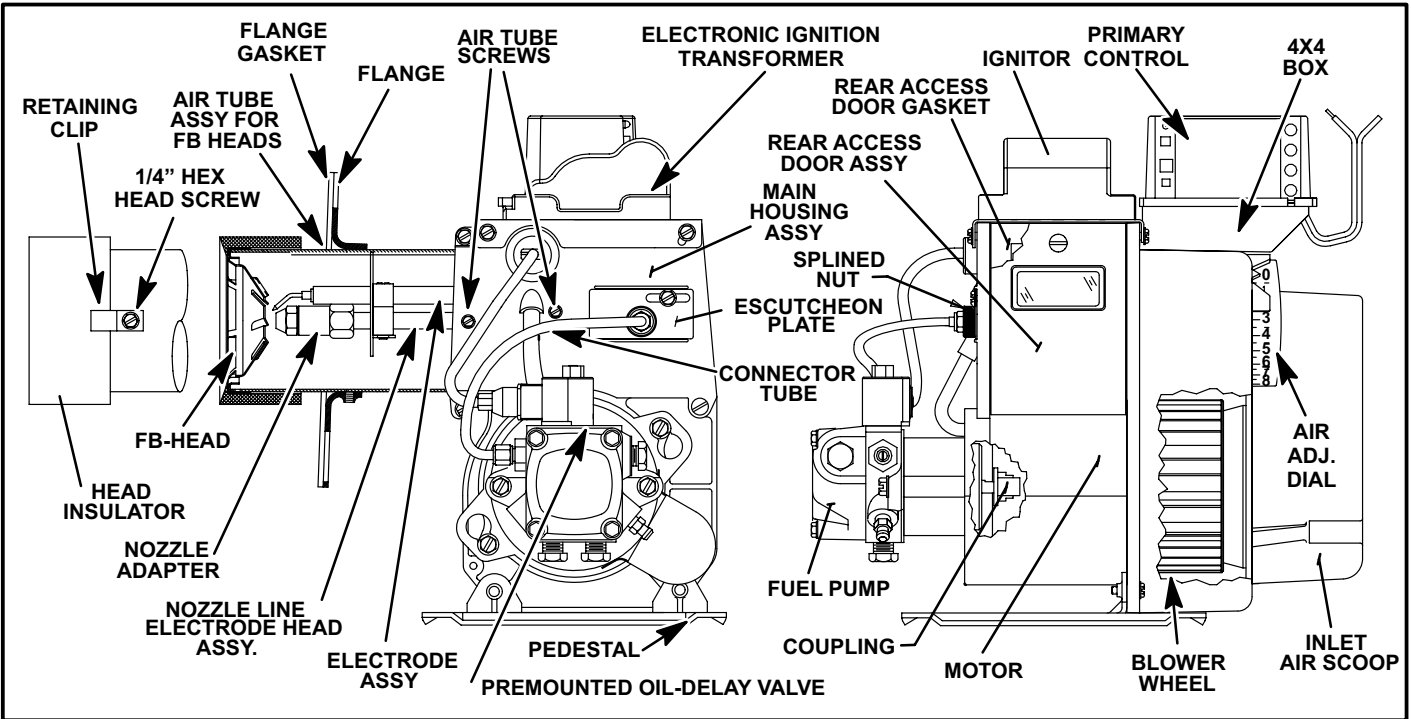

Figure 2

Requirements

WARNING

Product contains fiberglass wool.

Disturbing the insulation in this product during installation, maintenance, or repair will expose you to fiberglass wool dust. Breathing this may cause lung cancer. (Fiberglass wool is known to the State of California to cause cancer.)

Fiberglass wool may also cause respiratory, skin, and eye irritation.

To reduce exposure to this substance or for further information, consult material safety data sheets available from address shown below, or contact your supervisor.

Lennox Industries Inc.

**P.O. Box 799900
Dallas, TX 75379-9900**

Installation of Lennox oil-fired furnaces must conform with the National Fire Protection Association Standard for the Installation of Oil Burning Equipment, NFPA No. 31, the National Electrical Code, ANSI/NFPA No.70 (in the U.S.A.), CSA Standard CAN/CSA-B139 (in Canada), Installation Code for Oil Burning Equipment, the Canadian Electrical Code Part1, CSA 22.1 (Canada), the recommendations of the National Environmental Systems Contractors Association and any state or provincial laws or local ordinances. Authorities having jurisdiction should be consulted before installation. Such applicable regulations or requirements take precedence over general instructions in this manual.

Chimneys and chimney connectors must be of the type and construction outlined in section 160 of NFPA No. 31.

Air for combustion and ventilation must conform to standards outlined in section 140 of NFPA No. 31 or, in Canada, CSA Standard B139. When installing OHR23 units in confined spaces such as utility rooms, two combustion air openings are required. Dimensions of combustion air openings are shown in table 1. One opening shall be below burner level and the other opening shall be no more than 6 inches from the room's ceiling.

The combustion air opening should provide a minimum free area one-half square inch per 1,000 Btu per hour input. This combustion air should be brought into the area containing the furnace below the level of the furnace burner.

IMPORTANT

An opening to the outside for combustion air is strongly recommended, especially in new homes. Refer to table 1 or the unit rating plate for specific combustion air opening dimensions.

**Table 1
Combustion Air Opening Dimensions**

Model No.	Combustion Air Opening Dimensions (2 required)
OHR23-105/120	10" X 20"
OHR23-140/154	11" X 22"

This unit is approved for clearances to combustible material as listed unit rating plate and in tables 2 or 3. Unit service and accessibility clearances take precedence over fire protection clearances.

**Table 2
Horizontal Installation Clearances**

Clearances	inches (mm)
Top of Cabinet	3 (76)
*Bottom and Rear of Cabinet	1 (25)
Front of Cabinet	24 (610)
Service Clearance (Front)	24 (610)
End of Supply Plenum	0 (0)
Supply Air Opening	0 (0)
Return Air Opening	0 (0)
Above Horizontal Warm Air Duct within 3 ft. (914mm) of Furnace	0 (0)
Flue Pipe Horizontal	7 (178)
Flue Pipe Vertical	7 (178)

**NOTE-When furnace is installed on combustible floor, 1" (25 mm) spacer legs must be installed to elevate unit off of mounting surface.*

**Table 3
Downflow Installation Clearances**

CLEARANCES	INCHES (MM)
Bottom of Plenum and Ductwork	1 (25)
Plenum Sides	1 (25)
Side of Cabinet	1 (25)
Rear of Cabinet	1 (25)
Front of Cabinet	16 (406)
Service Clearance (Front)	24 (610)
Flue Pipe Horizontal	1 (25)
Flue Pipe Vertical	7 (178)
Return Air Opening	0 (0)
*Floor	*Combustible

**NOTE-Clearance for installation on combustible floor if optional additive base is installed between the furnace and combustible floor. Not required in add-on coiling applications.*

NOTE — Downflow Application Only — For installation on combustible floors, appliance shall not be installed directly

on carpeting, tile or other combustible material other than wood flooring. When installed on wood flooring, the additive base must be used. See Unit Dimension illustration.

Unit must be adjusted to obtain a temperature rise within the range listed in table 4 in the "Adjustments" section.

When used in conjunction with a evaporator coil, the furnace shall be installed in parallel with or on the upstream side of the evaporator coil. In a parallel flow arrangement, the dampers or means to control flow of air shall be adequate to prevent chilled air from entering the furnace, and if manually operated, must be equipped with means to prevent operation of either unit unless dampers are in the full heat or full cool position.

When installed, furnace must be electrically grounded in accordance with local codes or, in the absence of local codes, with the current National Electric Code, ANSI/NFPA No. 70, if an external electrical source is utilized.

Field wiring connection with unit must meet or exceed specifications of type T wire and withstand a 63°F (17°C) temperature rise.

Installation

When installed, OHR23 furnaces must be level. If the furnace is not level, place fireproof wedges or shims between the low side of the furnace and floor. Make sure the weight of the furnace is evenly distributed on all four corners. Strain on sides of the cabinet causing cracking and popping noises may occur if weight of furnace is not evenly distributed.

Set the unit in desired location keeping in mind the clearances list in tables 2 and 3. Also keep in mind oil supply connections, electrical supply, flue connections and sufficient clearance for installing and servicing unit.

OHR23 series units may be installed in a crawl space under a house, utility room or in a wide variety of suspended applications.

A-Horizontal Application

The OHR23 furnace is shipped from the factory in the horizontal left hand air discharge application. Air flow may be reversed to right side discharge or unit may be used as downflow.

Reversing Airflow for Right Hand Discharge

- 1- Rotate the furnace 180° so that when facing the front, the warm discharge is to the right.
- 2- Remove the nuts in the bracket that hold the burner to the furnace front. Rotate the burner and burner mounting plate 180° and reinstall the nuts.
- 3- Remove the screws that hold the limit control in place. Use the provided knockout hole to relocate the limit control to the top side of the front panel.

Installation on Non-Combustible Material

Set the furnace on non-combustible material (such as concrete blocks, bricks or angle iron). Install spacer legs, provided with unit, by using the cabinet screws from each corner of the unit. Use a level to check level of furnace in at least two directions. Use shims or non-combustible material. A minimum clearance of 1" must be maintained between bottom of furnace and combustible material.

Suspended Installation

To suspend furnace, remove knockouts in top of panel at warm air discharge and at blower panel (Refer to unit dimensions). Use 3/8" rods cut to desired length. Use one flat washer and two nuts for each rod. One nut and the washer on the inside of unit and the other nut on the outside of unit (the locking nut). Level the unit by adjusting the nuts on the inside of unit. See figure 3 to suspend unit.

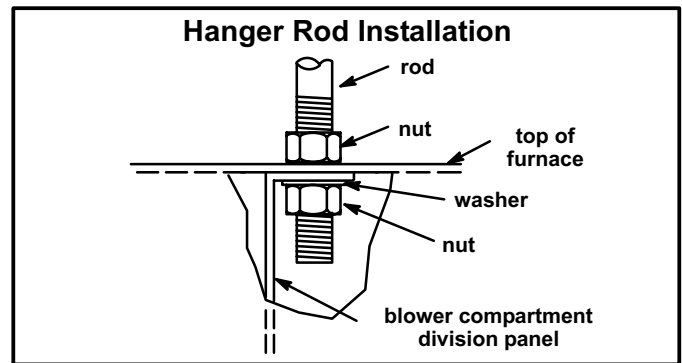

Figure 3

B-Downflow Application

When installing the OHR23 in a downflow position and on combustible flooring, a combustible floor base must be used. See Unit Dimension illustration.

- 1- Rotate the furnace so that return is on top and supply is on bottom. Refer to table 3 for clearances to combustible flooring.
- 2- Remove the nuts in the bracket that hold the burner to the furnace front. Rotate the burner and burner mounting plate 90° and reinstall the nuts.
- 3- It is also recommended that the upper rear screw holding the blower housing to the blower deck be removed before installation in a closet. Removing this screw allows for easy service and removal of the blower assembly in a closet installation.

Supply & Return Air Plenums

NOTE - The following are suggested procedures that should be followed when installing the supply and return air plenums.

- 1- Use sealing strips of fiberglass.
- 2- In all cases, the plenum should be secured to furnace or evaporator cabinet with sheet metal screws.

- 3- Both supply and return air plenums shall be square and least 18" long. They should be the same dimension as the furnace opening.
- 4- If unit is installed in a confined space such as a utility room where there is no complete return air duct system, a return air connection should be run (the same size as the return air opening) to a location outside the room containing the furnace.
- 5- Install supply and return air ducts as desired.

Optional Filter Kit

An Optional filter kit is available for OHR23 units. Kit 35K05 is used with OHR23-105/120 units, and kit 35K06 is used with OHR23-140/154 units. All kits include the following:

- 2 filters
- 3 rods
- 7 screws
- 1 rack assembly
- 1 panel

OHR23-140/154 Filter Rack Installation

- 1- Slide filter rack over return duct flanges.
- 2- Using a scribe through the filter rack mounting holes, mark seven mounting hole locations in the return end of the cabinet. See figure 4.
- 3- Remove filter rack and drill 1/8" diameter holes at the marked positions.
- 4- Place filter rack in position again and secure it to the cabinet using the sheet metal screws provided. Clearance for the screw driver is provided in outside holes of rack and in filter support angles.
- 5- Bend the ends of filter rods and hook ends through holes provided in top and bottom filter support angles.
- 6- Slide filter between the support angles and the plenum side for the filter rack. The filter rods hold the filter in place.

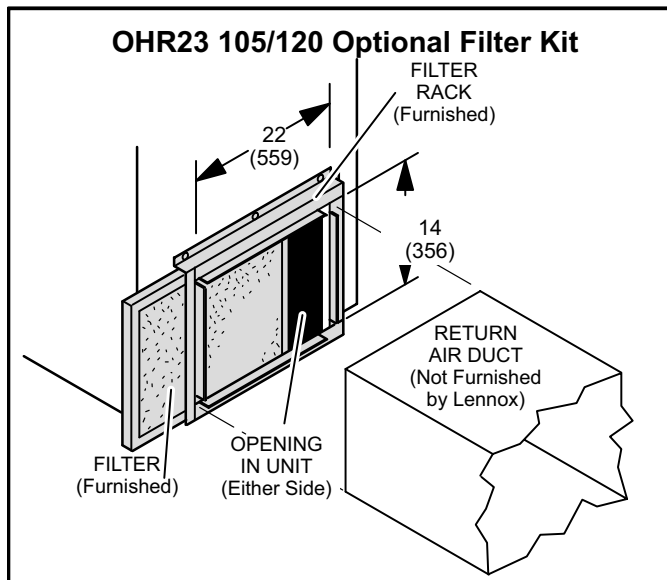

Figure 4

Unit Adjustments

Neither the nozzle setting nor the air adjustments are factory set. The furnace is fire-tested and the limit control is checked to make sure it functions properly; no factory settings are made. During installation, the furnace must be set up. The installing dealer/contractor must have and use proper test equipment in order to correctly set up the oil furnace. Proper testing equipment is required to ensure correct operation of the unit. The use of test equipment is now more critical than ever due to tighter tolerances needed to keep the furnace operating efficiently.

Among the test equipment for an oil furnace, the proper combustion test kit should contain the following:

- Draft gauge
- CO₂ or O₂ analyzer
- Smoke tester
- Pressure gauge
- High temperature thermometer
- Oil vacuum gauge
- Beckett T-500 gauge
- Knowledge of proper test equipment operation

CAUTION

Improper nozzle and/or air adjustment of this unit may result in sooting problems. Refer to the following set-up section for correct adjustment procedures.

Adjusting the Nozzle

Proper adjustment of the nozzle assembly is critical because alignment may have changed during shipping. Before the furnace and oil lines are installed, the nozzle assembly must be checked. This may easily be done by removing the entire burner assembly (not just the nozzle) from the furnace. The lower firing nozzle is factory installed. This should be verified by the installer. Inspect the spark transformer leads also to ensure they are still attached to the electrodes.

The burner assembly is attached to the vestibule panel by three nuts. Slots are provided in the mounting flange for removing the burner assembly from the vestibule. By loosening the nuts and by turning the whole burner assembly counterclockwise (figure 5), the entire burner assembly will come out of the furnace. There is adequate wire to remove the burner without disconnecting wires. Once removed, just turn the burner around in the vest panel area.

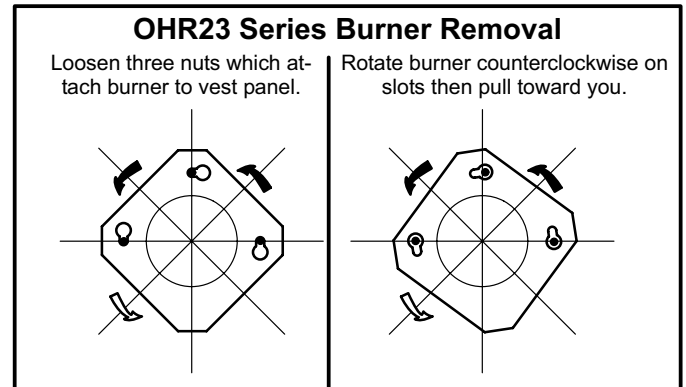

Figure 5

To correctly adjust the nozzle, use a Beckett #T-500 gauge. Insert the small end of the gauge into the end of the cone and measure from the flat of the end cone to the tip of the nozzle. When nozzle depth is correct, the tip of the nozzle should just touch the end of the gauge. Refer to the illustration sheet provided with the gauge. Note that the scale side of the gauge is not used for this purpose. Make corrections by sliding the nozzle assembly forward or backward within the blast tube (figure 6). At the same time, check the nozzle alignment.

To check nozzle alignment, again insert the small end into the end cone and measure the nozzle and electrode alignment against the center lines marked on the gauge (again refer to enclosed illustration sheet). If the nozzle is not centered, but found to be too far left or right, a new nozzle assembly will need to be ordered. Do not attempt to adjust by bending the 90 degree elbow in the oil line.

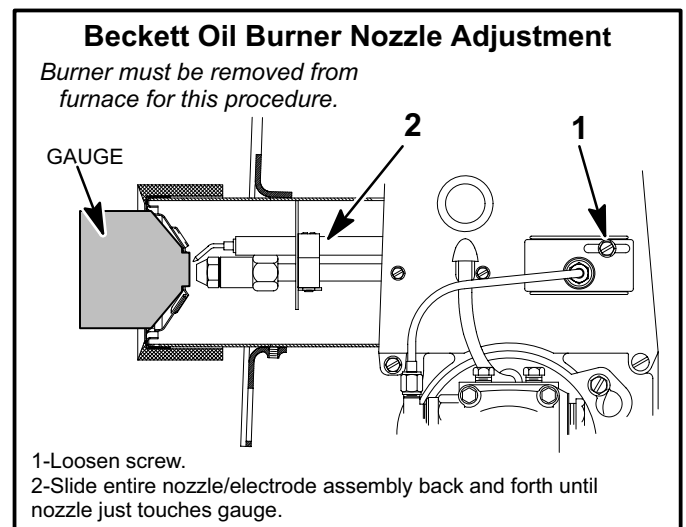

Figure 6

Venting

⚠ WARNING

The barometric damper shall be in the same atmospheric pressure zone as the combustion air inlet to the furnace. Deviation from this practice will cause improper burner operation and may result in a fire hazard.

⚠ CAUTION

Do not store combustible materials near the furnace or supply air ducts. The material (such as paint, motor oil, gasoline, paint thinner, etc.) may ignite by spontaneous combustion creating a fire hazard.

⚠ WARNING

This furnace is certified for use with type "L" vent. "B" vent must not be used with oil furnaces.

NOTE - Oil burning equipment may be vented into an approved masonry chimney or type L vent. (Type L vent is similar in construction to type B gas vent except it carries a higher temperature rating and is constructed with an inner liner of stainless steel rather than aluminum).

Prior to installation of unit, make a thorough inspection of the chimney to determine whether repairs are necessary. Make sure the chimney is properly constructed and sized according to the requirements of the National Fire Protection Association. The smallest dimensions of the chimney should be at least equal to the diameter of the furnace vent connector. Make sure the chimney will produce a steady draft sufficient to remove all the products of combustion from the furnace. A draft of at least .04" w.c. (9.9 Pa) is required during burner operation.

- 1 - Local building codes may have more stringent installation requirements and should be consulted before installation of unit.
- 2 - The vent connector should be as short as possible to do the job.
- 3 - The vent connector should not be smaller than the outlet diameter of the vent outlet of the furnace.
- 4 - Pipe should be at least 24 gauge galvanized.
- 5 - Single wall vent pipe should not run outside or through any unconditioned space.
- 6 - Chimney should extend 3 feet (0.9 m) above highest point where the vent passes through the roof, and 2 feet (0.6 m) higher than any portion of a building within a horizontal distance of 10 feet (3 m).
- 7 - The vent must not pass through a floor or ceiling. Clearances to single wall vent pipe should be no less than 6" (152 mm); more if local codes require it.

- 8 - The vent may pass through a wall where provisions have been made for a thimble as specified in the Standards of the National Board of Fire Underwriters. See figure 7.

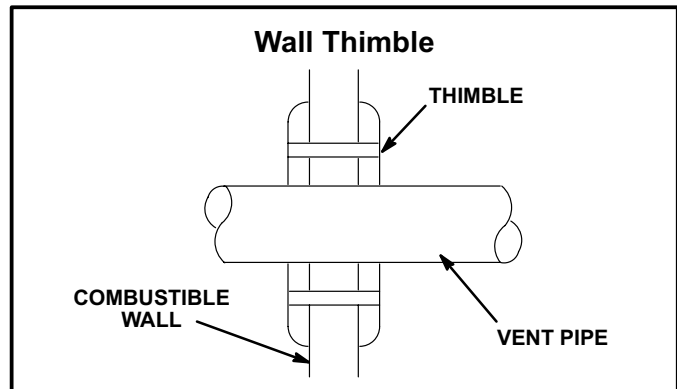

Figure 7

- 9 - The vent pipe should slope upward toward the chimney on horizontal run at least 1/4 inch (6 mm) to the foot (0.3 m) and should be supported by something other than the furnace, such as isolation hangers. See figure 8.

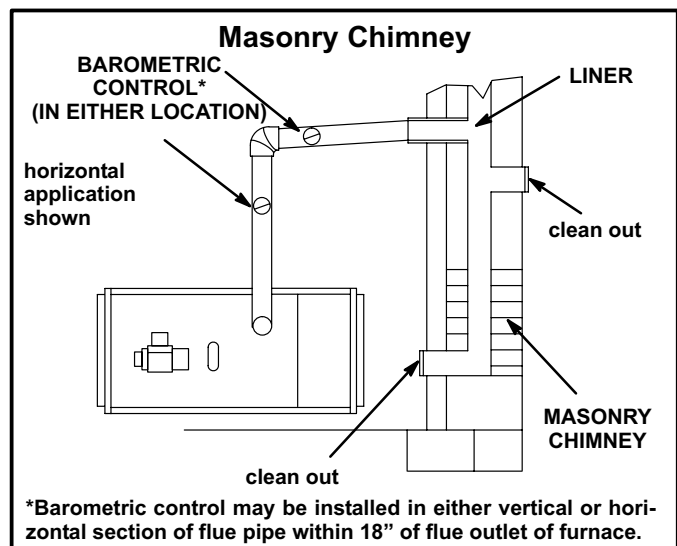

Figure 8

- 10- Extend the vent pipe into the chimney so that it is flush with the inside of the vent liner. Seal the joint between the pipe and the liner.
- 11- The furnace shall be connected to a factory built chimney or vent complying with a recognized standard, or masonry or concrete chimney lined with a lining material acceptable to the authority having jurisdiction.
- 12- When two or more appliances vent into a common vent, the area of the common vent should not be less than the area of the largest vent or vent connection plus 50% of the areas of the additional vent or vent connection. Chimney must be able to sufficiently vent all appliances operating at the same time.

- 13- The vent pipe shall not be connected to a chimney vent serving a solid fuel appliance or any mechanical draft system.
- 14- All unused chimney openings should be closed.
- 15- All vent pipe run through unconditioned areas or outside shall be constructed of factory built chimney sections. See figure 9.
- 16- Where condensation of vent gas is apparent, the vent should be repaired or replaced. Accumulation of condensation in the vent is unacceptable.
- 17- Vent connectors serving this appliance shall not be connected into any portion of mechanical draft systems operating under positive pressure.
- 18- Keep the area around the vent terminal free of snow, ice and debris.

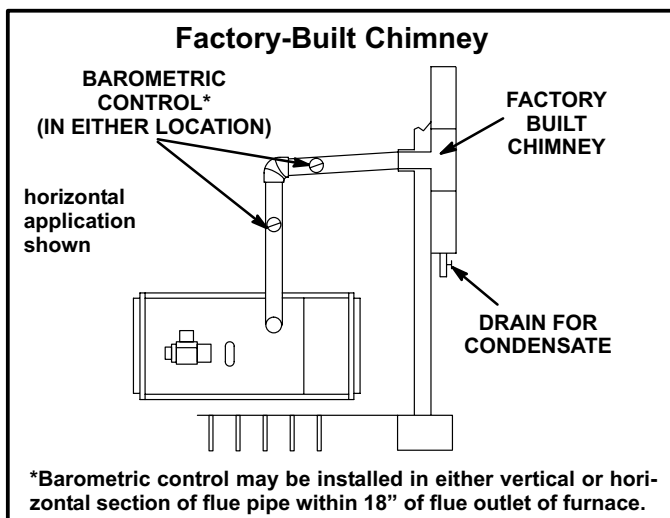

Figure 9

Combustion and Ventilation Air (Confined and Unconfined Spaces)

In the past, there was no problem in bringing in sufficient amounts of outdoor air for combustion -- infiltration provided all the air that was needed and then some. In today's homes built with energy conservation in mind, tight construction practices make it necessary to bring in air from outside for combustion. Consideration must also be given to the use of exhaust fans, appliance vents, chimneys and fireplaces because they force additional air that could be used for combustion out of the house. Unless outside air is brought into the home for combustion, negative pressure (pressure outside is greater than inside pressure) will build to the point that a down draft can occur in the furnace vent pipe or chimney. Combustion gases enter the living space creating a potentially dangerous situation.

The importance of the previous paragraph cannot be overstated. Users may inadvertently block fresh air intakes after installation.

In the absence of local codes concerning air for combustion and ventilation, the following section outlines guidelines and recommends procedures for operating oil furnaces in a manner that ensures efficient and safe operation. Special consideration must be given to combustion air needs as well as requirements for exhaust vents and oil piping.

Combustion Air Requirements

⚠ CAUTION

Insufficient combustion air can cause headaches, nausea, dizziness or asphyxiation. It will also cause excess water in the heat exchanger resulting in rusting and premature heat exchanger failure. It can also cause property damage.

All oil-fired appliances require air to be used for the combustion process. If sufficient amounts of combustion air are not available, the furnace or other appliance will operate in an inefficient and unsafe manner. Enough air must be provided to meet the needs of all fuel-burning appliances, as well as appliances such as exhaust fans which force air out of the home. When fireplaces, exhaust fans, or clothes dryers are used at the same time as the furnace, much more air is required to ensure proper combustion and to prevent a down-draft situation. Insufficient amounts of air also cause incomplete combustion which can result in sooting. Requirements for providing air for combustion and ventilation depend largely on whether the furnace is installed in an unconfined or confined space.

Unconfined Space

An unconfined space is an area such as a basement or large equipment room with a volume greater than 50 cubic feet (1.4 cubic meters) per 1,000 Btu (293 W) per hour of the combined input rating of all appliances installed in that space. This space also includes adjacent rooms which are not separated by a door. Though an area may appear to be unconfined, it might be necessary to bring in outdoor air for combustion if the structure does not provide enough air by infiltration. If the furnace is located in a building of tight construction with weather stripping and caulking around the windows and doors, follow the procedures outlined for using air from the outside for combustion and ventilation.

Confined Space

A confined space is an area with volume less than 50 cubic feet (1.4 cubic meters) per 1,000 Btu (293 W) per hour of the combined input rating of all appliances installed in that space. This definition includes furnace closets or small equipment rooms.

When the furnace is installed so that supply ducts carry air circulated by the furnace to areas outside the space containing the furnace, the return air must be handled by ducts which are sealed to the furnace casing and which terminate outside the space containing the furnace. This is especially important when the furnace is mounted on a platform in a confined space such as a closet or small equipment room. Even a small leak around the base of the unit at the platform

or at the return air duct connection can cause a potentially dangerous negative pressure condition. Air for combustion and ventilation can be brought into the confined space either from inside the building or from outside.

Air from an Adjacent Space

If the confined space housing the furnace adjoins space categorized as unconfined, air can be brought in by providing two permanent openings between the two spaces. Each opening must have a minimum free area of 1 square inch (6.4 square centimeters) per 1,000 Btu (293 W) per hour of the total input rating of all fuel-fired equipment in the confined space. Each opening must be at least 100 square inches (614.5 square centimeters). One opening shall be within 12" (305 mm) of the top of the enclosure and one opening within 12" (305 mm) of the bottom (See figure 10).

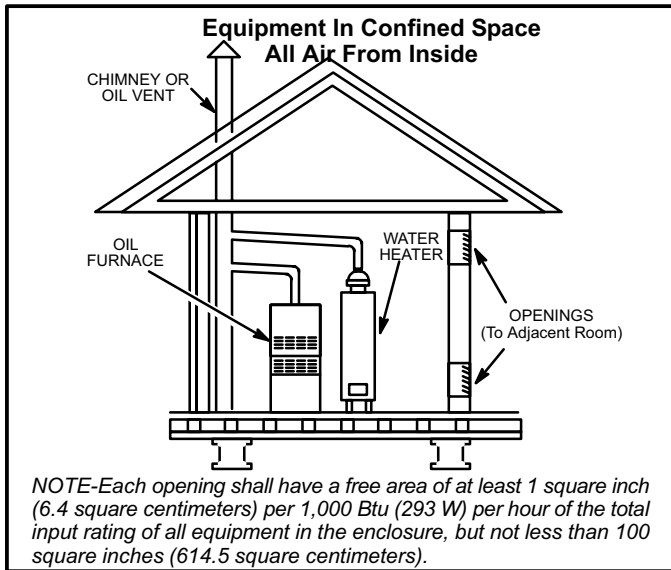

Figure 10

Air from Outside

If air from outside is brought in for combustion and ventilation, the confined space shall be provided with two permanent openings. One opening shall be within 12" (305 mm) of the top of the enclosure and one within 12" (305 mm) of the bottom. These openings must communicate directly or by ducts with the outdoors or spaces (crawl or attic) that freely communicate with the outdoors or indirectly through vertical ducts. Each opening shall have a minimum free area of 1 square inch (6.4 square centimeters) per 4,000 Btu (1172 W) per hour of total input rating of all equipment in the enclosure (See figures 11 and 12). When communicating with the outdoors through horizontal ducts, each opening shall have a minimum free area of 1 square inch (6.4 square centimeters) per 2,000 Btu (586 W) per total input rating of all equipment in the enclosure (See figure 13).

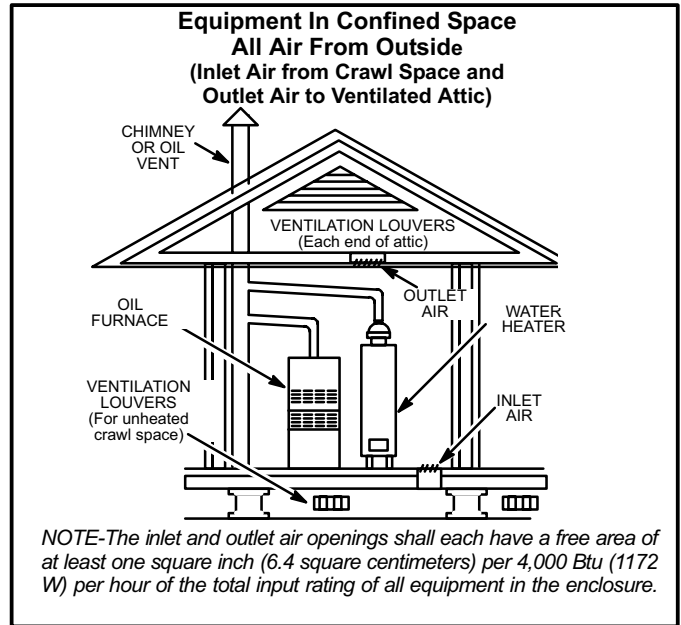

Figure 11

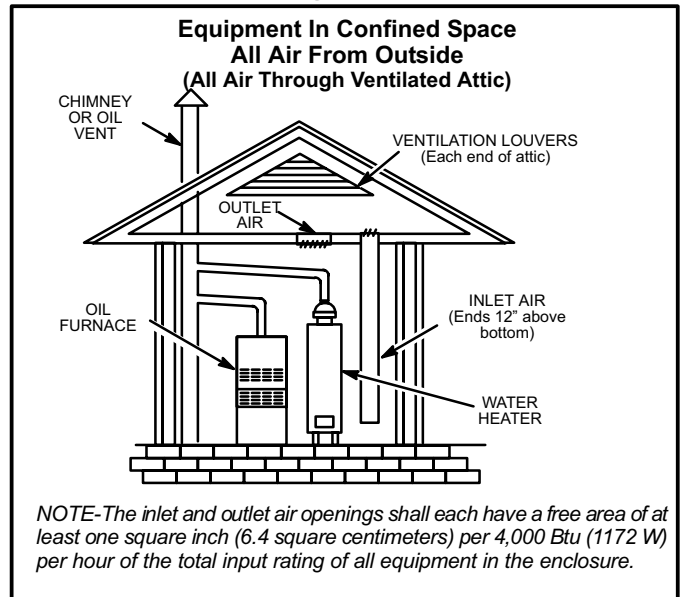

Figure 12

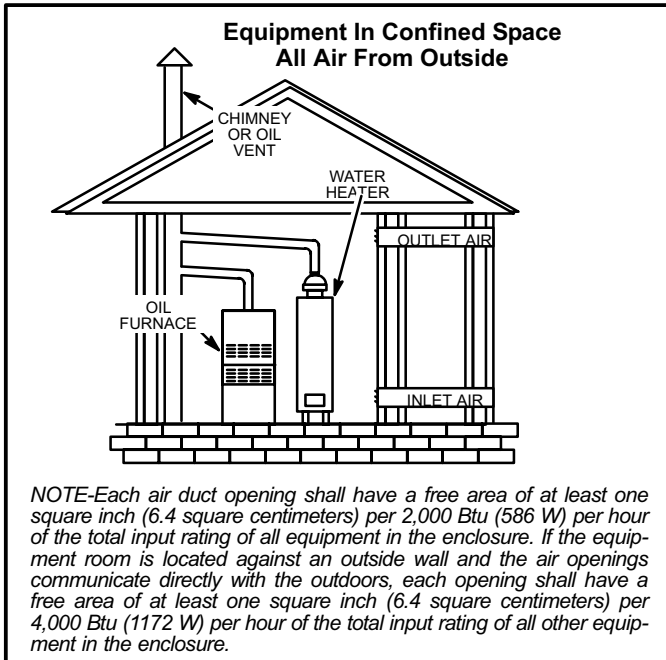

Figure 13

When ducts are used, they shall be of the same cross-sectional area as the free area of the openings to which they connect. The minimum dimension of rectangular air ducts shall be no less than 3" (76 mm). In calculating free area, the blocking effect of louvers, grilles, or screens must be considered. If the design and free area of protective covering is not known for calculating the size opening required, it may be assumed that wood louvers will have 20 to 25 percent free area and metal louvers and grilles will have 60 to 75 percent free area. Louvers and grilles must be fixed in the open position or interlocked with the equipment so that they are opened automatically during equipment operation.

⚠ CAUTION

The barometric control shall be in the same atmospheric pressure zone as the combustion air inlet to the furnace. Deviation from this practice will cause improper burner operation and may result in a fire hazard or injury.

Direct Connection of Outdoor Air for Combustion

The Beckett AFII burner was designed to allow for direct air intake piping (4" [102 mm]). The maximum equivalent length of pipe is 70 feet (21.3 m). A 90° elbow equals 6feet (1.8 m). The enclosed intake pipe ring may be used to facilitate direct air intake to the burner through the right side of the cabinet. The AFG burner requires a special kit for direct air intake. Refer to kit instructions.

To convert the AFII burner from confined space to outside combustion air, simply remove the three screws attaching the inlet air scoop to the burner and insert 4" (102 mm) direct air intake piping.

The use of a barometric relief placed in the intake pipe is recommended when outdoor combustion air is directly connected to the burner. This will allow confined space air to be used as combustion air in the event that the opening to the outdoor air becomes blocked. Using a barometric relief in the intake will reduce the chance of sooting.

CAUTION

DO NOT USE a barometric draft relief in exhaust vent pipe if outdoor combustion air is connected directly to the burner.

Removal of Unit from Common Venting System

In the event that an existing furnace is removed from a venting system commonly run with separate gas appliances, the venting system is likely to be too large to properly vent the remaining attached appliances. The following test should be conducted while each appliance is in operation and the other appliances not in operation remain connected to the common venting system. If the venting system has been installed improperly, the system must be corrected as outlined in the previous section.

- 1- Seal any unused openings in the common venting system.
- 2- Visually inspect the venting system for proper size and horizontal pitch and determine there is no blockage or restriction, leakage, corrosion or other deficiencies which could cause an unsafe condition.
- 3- If possible, close all building doors and windows and all doors between the space in which the appliances remaining connected to the common venting system are located and other spaces of the building. Turn on clothes dryers and any appliances not connected to the common venting system. Turn on any exhaust fans, such as range hoods and bathroom exhausts, so they will operate at maximum speed. Do not operate a summer exhaust fan. Close fireplace dampers.
- 4- Following the lighting instruction, place the appliance being inspected in operation. Adjust thermostat so appliance will operate continuously.
- 5- Test for spillage using a draft gauge.

6- After it has been determined that each appliance remaining connected to the common venting system properly vents when tested as outlined above, return doors, windows, exhaust fans, fireplace dampers and any other gas burning appliance to their previous condition of use.

7- If improper venting is observed during any of the above tests, the common venting system must be corrected.

Horizontal Venting

The OHR23 is approved for horizontal venting with the following mechanical vent systems:

Tjernlund (sideshot) #SS1C (Cat. #35E08) or Field Controls #SWG-5 (Cat. #35P08) with the CK-61 (Cat. #18N28) control kit. Refer to the manufacturers' installation instructions for proper installation procedures and service parts information.

Do not use the same vent with any other appliance when using a sidewall vent system.

Maximum permissible vent length is 70 equivalent feet. Minimum length is 15 equivalent feet. Calculate the equivalent vent pipe footage from the furnace to the mechanical vent system (Tjernlund or Field Controls) by adding the straight vent pipe length and the equivalent elbow lengths together.

Use the barometric draft control in the horizontal (sidewall) venting system. Locate the barometric draft control within 18 inches of the furnace flue outlet. See figure 14 for barometric draft control location.

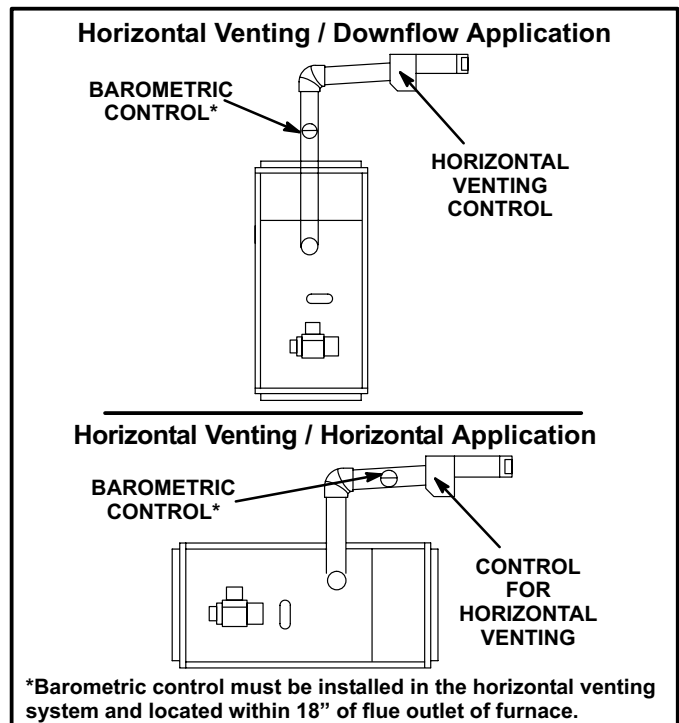

Figure 14

Flue Connections

⚠ IMPORTANT

When flue pipe is installed at less than minimum clearance listed in tables 2 and 3, radiation shields must be installed. See figure 15.

Use 24 gauge or heavier galvanized smoke pipe and fittings to connect furnace to vent. Maintain rise of at least one inch per foot. Connect flue pipe to chimney using the least number of elbows and angles possible. Flue pipe or vent connector must be inserted into but not beyond the outside wall of the chimney flue. No reduction in diameter of flue pipe is acceptable. It is best to have flue pipe as short and direct as possible. Where two or more appliances vent into a common flue, the area of the common flue should be at least equal to the area of the largest flue or vent connector, plus 50% of the area of any additional flues or vent connectors. Install barometric draft control (provided) and flue pipe according to instructions packed with control.

- 1- Install draft control, provided, and flue pipe according to instructions packed with control.
- 2- Connect flue outlet to chimney using at least 24 gauge vent pipe and fittings, the same size as the flue outlet.
- 3- Use the least number of elbows and angles possible. Slope flue pipe toward chimney approximately 1/4" for every foot of horizontal run. Flue pipe or vent connector must be inserted into but not beyond the outside wall of the chimney flue.

Where two or more appliances vent into a common flue the area of the common flue should be at least equal to the area of the largest flue or vent connector, plus 50% of the area of any additional flues or vent connectors.

Inspect flue pipe annually. Clean soot or ash from flue pipe, if necessary. If pipe is rusted, replace.

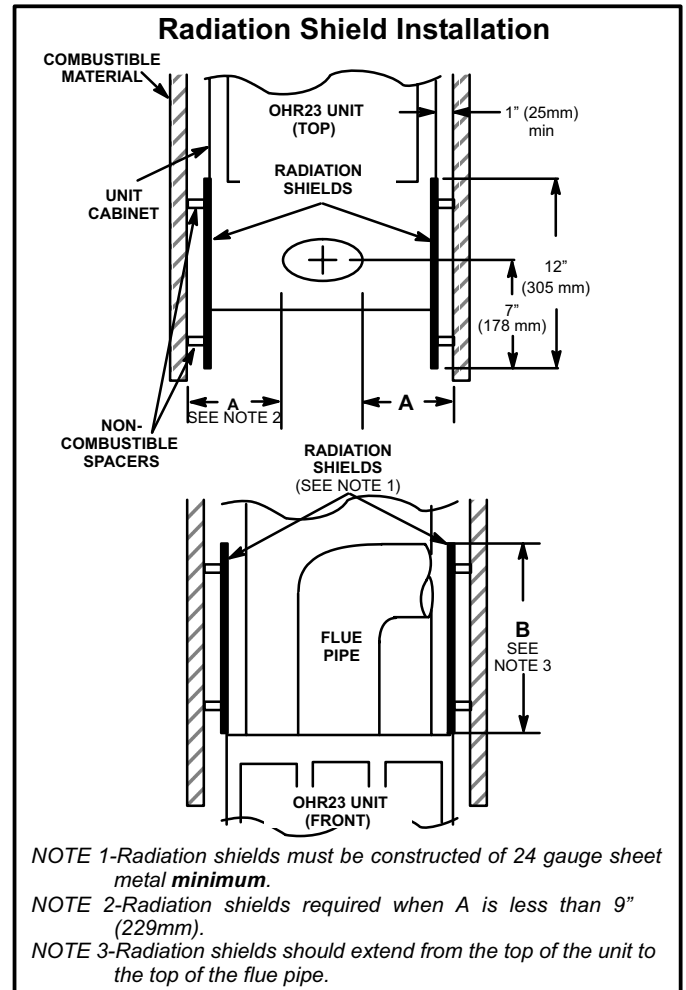

Figure 15

Oil Supply Lines Sizing

Ensure that the restrictions of the piping system, plus any lift involved, do not exceed the capability of the oil pump. Use the following guidelines when determining whether to use a single- or two-stage oil pump.

One-Pipe System

When using a one-pipe system with the oil tank even above the burner and a vacuum of 6" (152 mm) Hg or less, a single-stage fuel pump with a supply line and no return line should be adequate. See figure 16. Manual bleeding of the fuel pump is required on initial start up. Failure to bleed air from the oil pump could result in an air lock/oil starvation condition.

NOTE - As an extra precaution, cycle heating on and off ten times after bleeding air from the oil pump. This will eliminate air in the gun assembly.

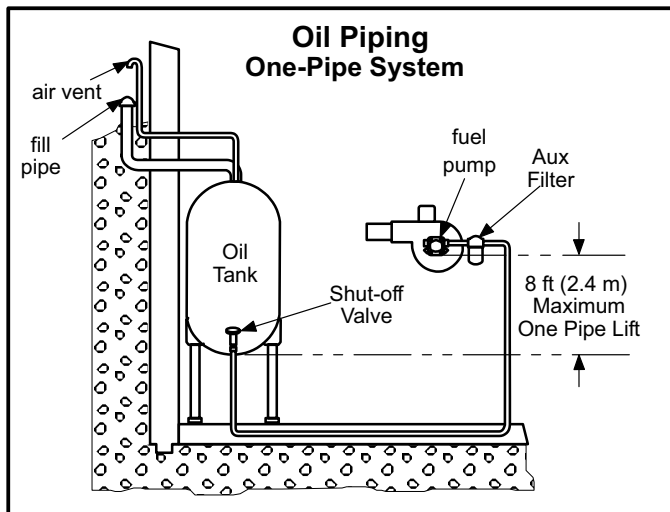

Figure 16

**Table 4
One-pipe Oil Sizing**

Line Length	Pipe Diameter (OD Tubing)
0-50' (15 m)	3/8" (10 mm)
51-100' (15 m)	1/2" (12 mm)

Two-Pipe System

When using a two-pipe system with the oil tank below the level of the burner, a single-stage fuel pump should be used in lift conditions of up to 10 feet (3 m) and/or a vacuum of 10" (254 mm) Hg or less. See figure 17. Use a two-stage fuel pump when lift exceeds 10 feet (3 m) and/or a vacuum of 10" (254 mm) Hg to 15" (381 mm) Hg. Both conditions require that you use a two-pipe system, which consists of a return line that purges the fuel pump of air by returning it to the tank. To determine the run and lift for piping, refer to table 5 .

To determine the length of the run for piping, refer to table 4 .

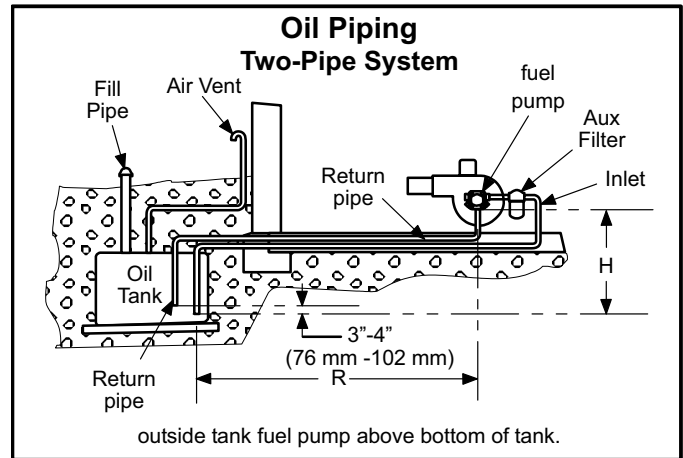

Figure 17

Use continuous lengths of heavy wall copper tubing or steel pipe for oil supply pipe. Install oil supply pipe under floor or near walls to protect it from damage. Avoid running pipes along joists or reverberating surfaces. Always use flare fittings. All fittings must be accessible. Do not use compression fittings.

⚠ IMPORTANT

Both oil supply and return pipes must be submerged in oil in the supply tank.

**Table 5
Two-Pipe Maximum Pipe Length (H + R)**

Lift "H"	3450 RPM - 3 GPH (11.4 LPH)			
	3/8" (10 mm) OD Tubing		1/2" (12 mm) OD Tubing	
	Single Stage	Two Stage	Single Stage	Two Stage
0' (0.0 m)	84' (25.6 m)	93' (28.3 m)	100' (30.5 m)	100' (30.5 m)
2' (0.6 m)	73' (22.3 m)	85' (25.9 m)	100' (30.5 m)	100' (30.5 m)
4' (1.2 m)	63' (19.2 m)	77' (23.5 m)	100' (30.5 m)	100' (30.5 m)
6' (1.8 m)	52' (15.8 m)	69' (21.0 m)	100' (30.5 m)	100' (30.5 m)
8' (2.4 m)	42' (12.8 m)	60' (18.3 m)	100' (30.5 m)	100' (30.5 m)
10' (3.0 m)	31' (9.4 m)	52' (15.9 m)	100' (30.5 m)	100' (30.5 m)
12' (3.7 m)	21' (6.4 m)	44' (13.4 m)	83' (25.3 m)	100' (30.5 m)
14' (4.3 m)	---	36' (11.0 m)	41' (12.5 m)	100' (30.5 m)
16' (4.9 m)	---	27' (8.2 m)	---	100' (30.5 m)
18' (5.5 m)	---	---	---	76' (23.2 m)

Oil Supply Line & Filter Connections

One-Pipe Systems

CAUTION

Do not install the bypass plug into the pump on one-pipe systems.

The burner is shipped with fuel pump set for one-pipe operation. For one-pipe systems, the oil supply pipe is connected to the inlet tap on the pump. A one-pipe system should only be used where there is gravity oil flow to the pump and the pipe is not run at any point above the oil level in the tank.

- 1 - Connect the inlet pipe to the pump inlet. Start the burner.
- 2 - Arrange the primary burner control for continuous operation during purging. See figure 16.
- 3 - Turn the bleed valve one turn counterclockwise to open.
- 4 - Bleed the unit until all air bubbles disappear.
NOTE - Hurried bleeding will prevent the unit from operating properly.
- 5 - Tighten the bleed valve securely.

Two-Pipe Systems

If the installation requires a two-pipe operation, install the bypass plug included in the bag which is attached to the pump. To convert the pump, install the bypass plug according to the provided pump instructions. Notice in the two-pipe system the return pipe must terminate in the tank 3" (76 mm) to 4" (102 mm) above the supply inlet. Ensure the return pipe terminates at the correct measurement or air may escape into the system. This could result in loss of prime.

NOTE- If using an outside tank in cold climates a number one fuel or an oil treatment is strongly recommended.

- 1 - Remove 1/4" plug from return port.
- 2 - Insert bypass plug and tighten it. See figure 17.
- 3 - Attach the return and inlet pipes. Start the burner. Air bleeding is automatic.
NOTE - If a faster bleed is necessary, open the bleed valve.
- 4 - The return pipe must terminate 3" to 4" above the supply pipe inlet. See figure 17.
NOTE - If the return pipe does not terminate where it should, air may enter the system, and prime may be lost.

An oil filter is required for all models. Install filter inside the building between the tank shut-off valve and the burner. Locate filter close to burner for easy maintenance. Table 6 lists the filters for the OHR23 furnace.

Table 6
Installation Clearances inches (mm)

Oil Filters	Cat. Number
10 micron filter (no mounting bracket)	81P89
10 micron filter (mounting bracket)	53P92
10 micron replacement cartridge for filter, 45 gph	53P93
Filter restriction indicator gauge	53P90

Consult burner manufacturer's instructions packaged with unit for further details concerning oil supply pipe connections.

Leak Check

After oil piping is completed, carefully check all piping connections (factory and field) for oil leaks.

Oil Line Heater (Optional)

An oil line heater is available for the burner nozzle. When applied to units installed in cold areas, the heater warms the oil line for start-up.

Electrical Wiring

All wiring must conform to the National Electric Code (NEC), or Canadian Electric Code (CEC) and any local codes. Refer to figure 18 for terminal designations on blower control.

- 1- Refer to appliance rating plate for proper fuse size.
- 2- Install room thermostat and make wire connections to the blower control. Avoid installing thermostat on an outside wall or where it can be affected by radiant heat. Set the adjustable heat anticipator on thermostat according to the wiring diagram sticker provided on unit.
- 3- Install a separate fused disconnect switch near unit so power can be shut off for servicing.
- 4- Complete line voltage wiring from disconnect switch near unit to make-up box.
NOTE - An equipment ground screw is provided. Refer to unit wiring diagram and figure 18 for OHR23 series units. Ground unit using a suitable ground wire.
- 5- Any accessory rated up to 1 amp can be connected to the accessory terminal. The accessory terminal is energized whenever the blower is in operation.

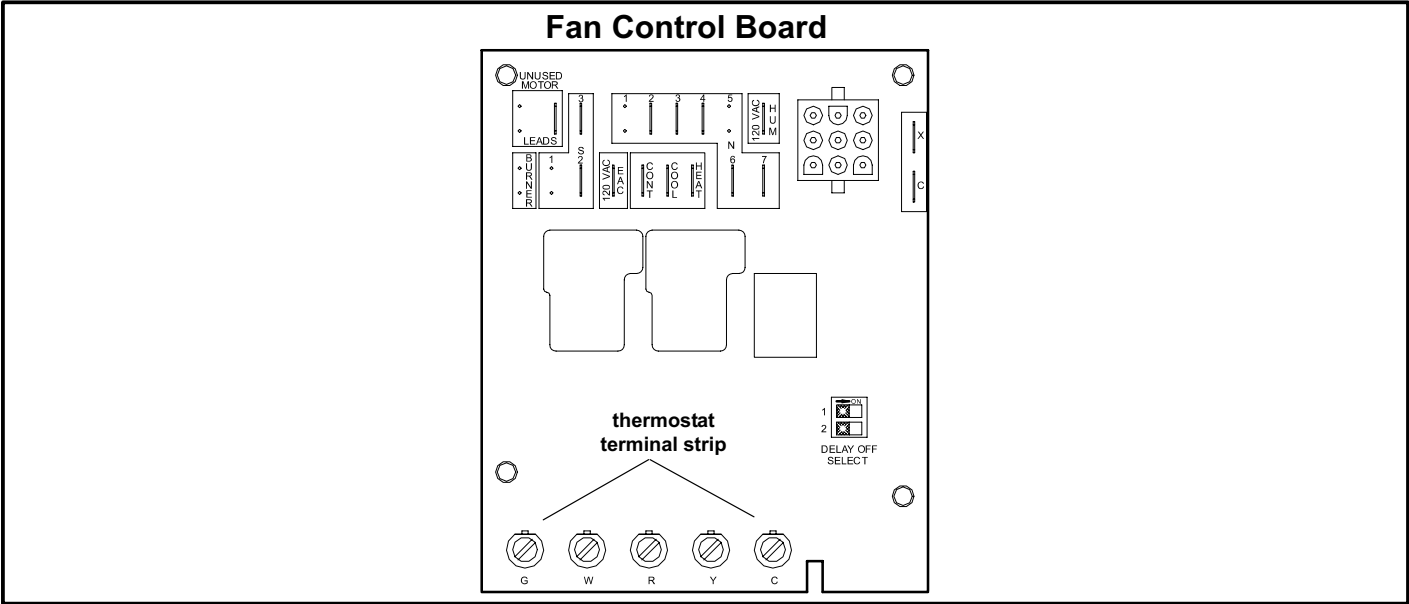

Figure 18

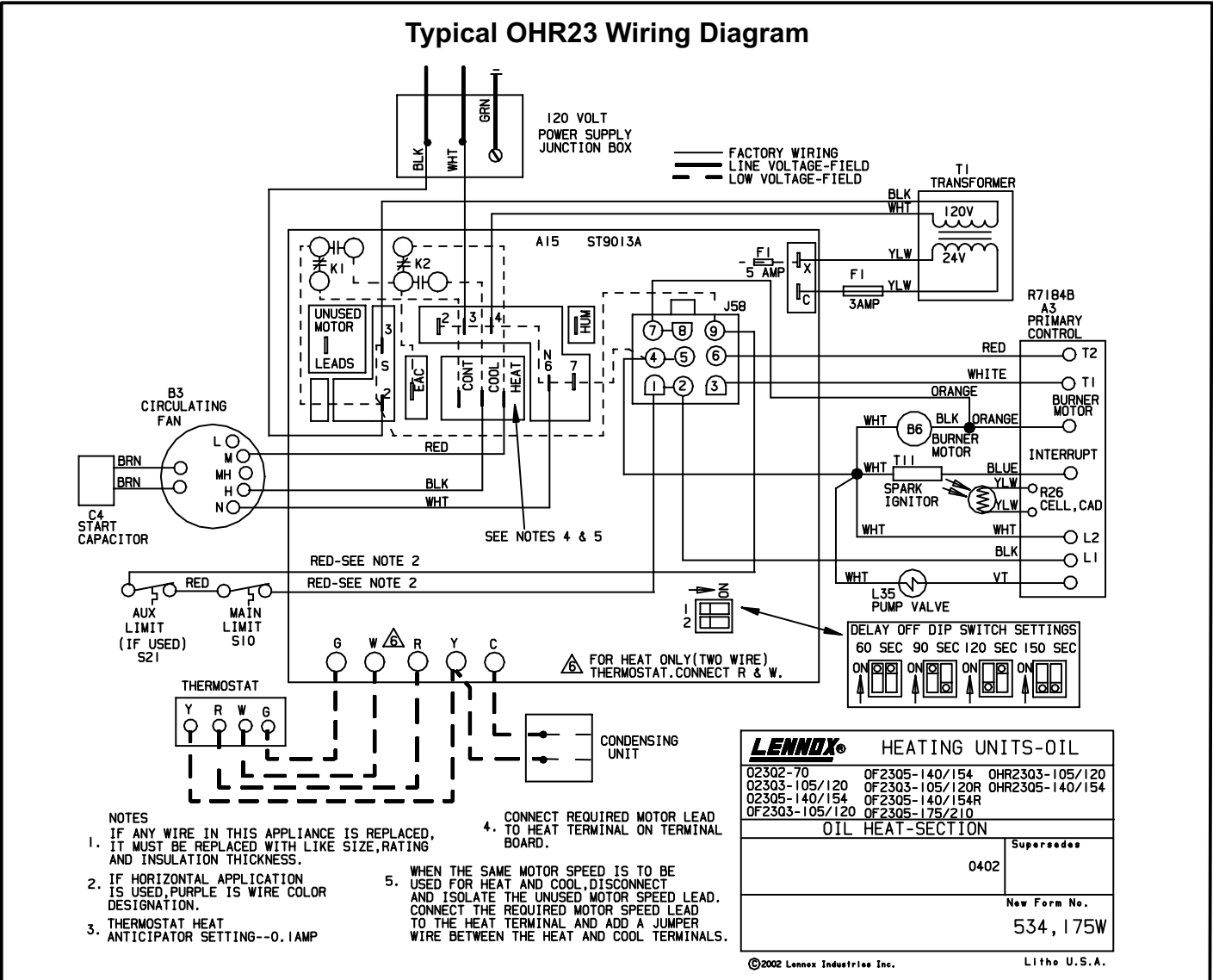

Figure 19

Unit Start-Up & Adjustments

Before starting unit, make sure the oil tank is adequately filled with clean No. 1 or No. 2 furnace oil.

NOTE - Water rust or other containments in oil supply system will cause malfunction and failure of the internal parts of the fuel unit.

⚠ CAUTION

Never burn garbage or paper in the heating system. Never leave papers near or around the unit.

⚠ CAUTION

Blower door must be in place before start-up.

- 1- Set thermostat for heating demand and turn on electrical supply to unit.
- 2- Check initial air adjustment. All units are equipped with an air adjustment dial on the right side of the burner. See burner parts arrangement illustration.
- 3- Turn unit on. Place a can or container under the bleed port located on the fuel pump. Loosen nut on bleed port to release air and oil mixture from fuel line. Allow mixture to escape until a steady stream of oil is emitted from the port. Drain at least 1/2 pint of oil from the pump. Retighten nut on bleed port. If lockout occurs, press reset button and continue with bleed procedure.
NOTE - A two-line fuel system will normally bleed itself by forcing air back to the tank through the return line. This type of bleeding procedure is not necessary.
- 4- If burner fails to start, push reset button on primary safety control and the burner motor reset button once. See part arrangement illustration.

⚠ CAUTION

Do not push the reset button on the primary control more than one time.

5- If burner fails to light again, refer to the troubleshooting section in this manual.

A - Fuel Pump Pressure

Measure fuel pump pressure with unit off. Attach pressure gauge to pump outlet. Turn unit on and check pressure and compare to table 4. Adjust if necessary.

B - Temperature Rise

To measure temperature rise, place plenum thermometers in warm air and return air plenums. Locate thermometer in warm air plenum where thermometer will not “see” the heat exchanger to prevent it from picking up radiant heat. Set thermostat to its highest setting to start unit. After plenum thermometers have reached their highest and steadiest readings, subtract the readings. The difference in temperatures in the supply and return air plenums should approximate the temperature rise range listed in table 4 and the appliance rating plate. If not, adjust the blower motor pulley to adjust the blower speed.

C - Limit Control

Limit Control — Do not adjust from factory setting.

D - Fan Control

The fan on time of 30 seconds is not adjustable. Fan off time (time that the blower operates after the heat demand has been satisfied) can be adjusted by moving the delay switches on the fan control board. Fan off time will affect comfort and is adjustable to satisfy individual applications. See figure 20. Set the heat fan off delay switches to either 60, 90, 120, or 150 seconds. The factory setting is 90 seconds.

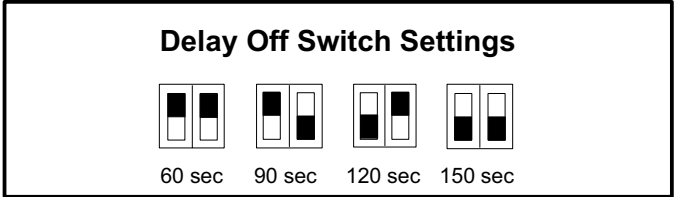

Figure 20

Table 7

OHR23 Unit	Nozzle Size, Spray Angle And Pattern	Input Rating Btu/Hr	Output Rating Btu/Hr	Head	Temp. rise +10_F hrz/down
-105/ -120	.65GPH-.80°,B for -105 input *.75GPH-.80°,B for -120 input	105,000 119,000	85,000 97,000	FB3	70/70
-140/ -154	.85GPH - .80°,B for -140 input *1.0GPH-.80°,B for -154 input	140,000 154,000	113,000 125,000	FB6	60/70

*Nozzle must be field provided for field conversion to higher heating input. Oil burner pump pressure is 140 psi for each unit.

E - Burner Adjustment

The following steps are essential to the proper operation of OHR23 series oil furnaces. To prevent sooting, these instructions must be followed in sequence:

1 - Draft

This test should be taken at the breach between the outlet of the vent connector and the barometric draft control. Generally a 1/4" hole will need to be drilled for the draft gauge to be inserted into the vent connector.

A minimum of 0.03 draft must be established without the burner in operation. With the burner in operation, the draft should be 0.04 to 0.05. This is VERY critical to the flame retention head burners.

Oil furnace installations also require careful inspection to make sure the chimney is in good shape and can accommodate the products of combustion. The temperature in the unconditioned space will also affect the draft if long vent connectors are allowed to get too cold.

2 - Overfire Draft

This test should be taken with the burner in operation. Remove the screw from the center of the inspection port. Insert your draft gauge into the hole.

A reading of the overfire draft should be 0.02 less than the reading found in the vent connector. If a positive reading is seen at this point, the combustion fan is pumping too much air into the heat exchanger. Make the necessary adjustments at the air adjustment dial.

3 - Smoke Test

The smoke test should be taken at the hole drilled in step 1. Do not exceed #1 smoke.

4 - CO₂ Test

Again, take this sample at the vent pipe. With the unit firing at a trace of smoke, take a sample of the CO₂.

From the results of this test, a "window of operation" will be determined. This window of operation establishes some tolerance. The tolerance the installer builds in provides room within the set-up for those things which might affect combustion. Those things which might affect combustion can then do so without causing the unit to start sooting/smoking. Things which might affect combustion include a nozzle going bad, draft that changes during different climatic conditions, dirty oil, dirt obstructing the air inlet, etc.

To build a window of operation, set the burner up so it does not exceed 13% co₂.

5 - Retest the Smoke

With a drop in the CO₂ and increase in the air you should see that the smoke has returned to 0.

6 - Retest the Overfire Draft

This test serves to confirm that you have not increased the air too much. Again you do not want a positive pressure at the test port. It should still be 0.02 less than the draft pressure reading taken at the breach. You may need to increase the stack draft by adjusting the barometric draft control.

7 - Stack Temperature

Take a stack temperature reading in the vent pipe. Subtract the room air temperature from the stack temperature. This will give you the net stack temperature. Use the efficiency charts provided in most CO₂ analyzers to determine furnace efficiency.

Service

A-Servicing Filter

NOTE - Under no circumstances should the access panels to the blower compartment be left off or left partially open.

- 1- Throw-Away Type Filters — Filters should be checked monthly and replaced when necessary to assure proper furnace operation. Replace filters with like kind and size filters.
- 2- Reusable Type Filters — Filters should be checked monthly and cleaned when necessary to assure proper furnace operation. Use warm water and a mild detergent. Replace filter when dry. Permanent filters supplied with OHR23 furnaces do not require oiling after cleaning. Examine filter label for any for special instructions that may apply.

B - Blower

Blower motor is pre-lubricated and sealed for extended operation. No further lubrication is required. Disconnect power to unit before cleaning blower wheel for debris.

C - Nozzle

Replace nozzle every year to to ensure proper operation. Clogged nozzles will result in improper firing or non-firing of unit.

D - Flue Pipe Inspection

The flue pipe should be inspected annually by a qualified service technician. Remove and clean any soot or ash found in the flue pipe. Inspect pipe for holes or rusted areas. If replacement is necessary, replace with the same size and type as required by code. Inspect the flue draft control device and replace if found defective.

E - Cleaning Heat Exchanger

- 1- Remove the vent pipe from the furnace.
- 2- Remove the locking screws and the caps from the clean-out tubes. Remove flue access elbow.
- 3- Using a long spiral wire brush, sweep down the outer drum of the heat exchanger. Then using the hose attachment, vacuum out loose debris.
- 4- Remove the locking screw and cap from the observation tube and with the spiral wire brush, reach upward toward the rear of the heat exchanger to clean out the crossover tube.

CAUTION

Do not attempt to clean the combustion chamber. It can be easily damaged.

- 5- Replace the clean-out caps and flue access elbow. Make sure locking screws are secure.

- 6- Brush out and vacuum the vent outlet area of the outer drum and replace vent pipe.
- 7- Clean around burner, blower deck and vestibule area.

NOTE - A heat exchanger clean-out kit ABRSH380 (35K09) is available from Lennox.

OHR23 Start-Up & Performance Check List

Job Name _____ Job No. _____ Date _____

Job Location _____ City _____ State _____

Installer _____ City _____ State _____

Unit Model No. _____ Serial No. _____ Serviceman _____

HEATING SECTION

Electrical Connections Tight? Supply Voltage _____ Blower Motor Amps _____

Blower Motor H.P. _____ Burner Model No. _____ Serial Number _____

Piping Connections Tight? All Valves Open? Blower Motor Lubrication O.K.?

Oil Pump Pressure [recommended minimum 140 psi] _____

PROPER DRAFT

Draft Reading (recommended .03-.04 inches w.c.) _____

% CO₂ (recommended 12%) _____

Flue Connections Tight? Fan Control Setting (maximum 130°F 55°C) _____

Fan Control Cutout _____ Temperature Rise _____

Filter Clean & Secure? Vent Clear?

THERMOSTAT

Calibrated? Heat Anticipator Properly Set? Level?

Troubleshooting

Burner failure or improper operation can result from a number of different causes.

Often the cause can be pinpointed by observing the different types of failure or by the process of elimination. The fol-

lowing troubleshooting charts list some failures, causes and a sequence of steps to isolate the point of failure. Check the simplest and most obvious items before progressing to other items.

Troubleshooting: Fan board operating sequence

Action	System Response
Thermostat calls for heat. (W terminal is energized.)	ST9103A closes oil primary control T-T connections. Ignition system and oil primary control start the furnace. Oil flows as long as oil primary control senses flame. Burner motor is energized and heat fan on delay timing begins. When timing is complete, the circulating fan is energized at heat speed and warm air is delivered to the controlled space.
Thermostat ends call for heat. (W terminal is de-energized.)	Oil primary control is de-energized, terminating the burner cycle. Heat fan off delay timing begins. When timing is complete, the circulating fan is de-energized. ST9103A returns to standby mode (oil primary control and circulating fan are off).
Burner fails to light.	Oil primary control locks out within lockout timing (timing depends on oil primary control). Burner motor is de-energized. If heat fan has started, it continues through the selected delay off period.
Established flame fails.	Burner motor is de-energized and oil primary control goes into recycle mode. If selected heat fan off delay is longer than the recycle delay timing, the heat fan continues to run through the next trial for ignition.
Thermostat begins call for cool. (G and Y terminals are energized.)	Circulating fan is energized at the cool speed. Cooling compressor turns on immediately.
Thermostat ends call for cool. (G and Y terminals are de-energized.)	Circulating fan and cooling compressor turn off immediately.
Thermostat begins call for fan. (G terminal is energized.)	Circulating fan is energized immediately at cool speed. ST9103A may be factory-configured to operate heat speed in this mode.
Thermostat ends call for fan. (G terminal is de-energized.)	Circulating fan is de-energized.
Limit switch string opens.	Oil primary control shut off the burner. Circulating fan is energized immediately at heat speed. ST9103A opens oil primary control T-T connections. Circulating fan runs as long as limit string stays open. If there is a call for cooling or fan, the circulating fan switches from heat speed to cool speed.
Limit switch string closes.	ST9103A begins heat fan off delay sequence. Circulating fan turns off after the selected heat fan off delay timing. ST9103A closes oil primary control T-T connections. Oil primary control is energized, initiating burner light off.
Continuous circulating fan is connected. (Optional connectors are available for separate circulating fan speed tap.)	Circulating fan is energized at low speed when there is no call for heat, cool or fan. If fan operation is required by a call for heat, cool, or fan, the ST9103A switches off the continuous fan speed tap before energizing the other fan speed.
Electronic air cleaner is connected. (Optional connectors are available for 120 Vac electronic air cleaner.)	Electronic air cleaner (EAC) connections are energized when the heat or cool speed of the circulating fan is energized. EAC connections are <i>not</i> energized when the optional continuous fan terminal is energized.
Humidity control is connected. (Optional connectors are available for 120 Vac humidifier.)	Humidifier connections are energized when the burner motor is energized.

Troubleshooting: Burner fails to start.

Source	Procedure	Causes	Correction
Thermostat	Check thermostat settings.	Thermostat in OFF or COOL	Switch to HEAT .
		Thermostat is set too low	Turn thermostat to higher temperature.
Safety Overloads	Check burner motor, primary safety control, & auxiliary limit switch.	Burner motor overload tripped	Push reset button pump motor.
		Primary control tripped on safety	Reset primary control.
		Auxiliary limit switch tripped on safety	Reset auxiliary limit.
Power	Check furnace disconnect switch & main disconnect.	Open switch	Close switch.
		Blown fuse or tripped circuit breaker	Replace fuse or reset circuit breaker.
Thermostat	Touch jumper wire across thermostat terminals on primary control. If burner starts, then fault is in the thermostat circuit.	Broken or loose thermostat wires	Repair or replace wires.
		Loose thermostat screw connection	Tighten connection.
		Dirty thermostat contacts	Clean contacts.
		Thermostat not level	Level thermostat.
		Faulty thermostat	Replace thermostat.
CAD Cell	Disconnect the flame detector wires at the primary control. If the burner starts, fault is in the detector circuit.	Flame detector leads are shorted	Separate leads.
		Flame detector exposed to light	Seal off false source of light.
		short circuit in the flame detector	Replace detector.
Primary Control	Place trouble light between the black and white leads. No light indicates that no power is going to the control.	Primary or auxiliary control switch is open	Check adjustment. Set the maximum setting. Jumper terminals; if burner starts, switch is faulty, replace control.
		Open circuit between disconnect switch and limit control	Trace wiring and repair or replace it.
		Low line voltage or power failure	Call the power company.
	Place trouble light between the orange and white leads. No light indicates faulty control.	Defective internal control circuit	Replace the control.
Burner	Place the trouble light between the black and white leads to the burner motor. No light indicates that no power is getting to the motor.	Blown fuse	Replace the fuse.
	Place trouble light between the black and white leads to the blower motor. Light indicates power to the motor and burner fault.	Binding burner blower wheel	Turn off power and rotate the blower wheel by hand. If seized, free the wheel or replace the fuel pump.
		Sized fuel pump	
		Defective burner motor	Replace the motor.

Troubleshooting: Burner starts, but no flame is established.

Source	Procedure	Causes	Correction
Oil Supply	Check tank gauge or use dip stick.	No oil in tank	Fill tank.
	Coat dip stick with litmus paste and insert into bottom of tank.	Water in oil tank	If water depth exceeds 1 inch, pump or drain water.
	Listen for pump whine.	Tank shut-off valve closed	Open valve.
Oil Filters & Oil Line	Listen for pump whine.	Oil line filter is plugged	Replace filter cartridges.
		Kinks or restriction in oil line	Repair or replace oil line.
		Plugged fuel pump strainer	Clean strainer or replace pump.
	Open bleed valve or gauge port. Start the burner. No oil or milky oil indicates loss or prime.	Air leak in oil supply line	Locate and correct leak. Tighten all connections.
Oil Pump	Install pressure gauge on pump and read pressure. Should not be less than 140 psi.	Pump is partially or completely frozen. No pressure and the motor locks out on overload.	Replace pump.
		Coupling disengaged or broken - no pressure	Re-engage or replace coupling.
		Fuel pressure too low	Adjust to 100 psi.
Nozzle	Disconnect ignition leads. Observe the oil spray (gun assembly must be removed from unit). Inspect the nozzle for plugged orifice or carbon build-up around orifice.	Nozzle orifice plugged	Replace nozzle with the same size, spray angle, and spray type.
		Nozzle strainer plugged	
		Poor or off center spray	
Ignition Electrodes	Remove gun assembly and inspect electrodes and leads.	Fouled or shorted electrodes	Clean electrode leads.
		Dirty electrodes and leads	
		Eroded electrode tips	Clean electrode tips and reset the gap to 5/32 inches and correctly position tips.
		Improper electrode gap spacing	
		Improper position of electrode tips	
		Bad buss bar connection	Retension and realign.
		Cracked or chipped insulators	Replace electrode.
Cracked or burned lead insulators	Replace electrode leads.		
Ignition Transformer	Connect ignition leads to the transformer. Start burner and observe spark. Check line voltage to transformer primary.	Low line voltage	Check voltage at power source. Correct cause of voltage drop or call the power company.
		Burned out transformer windings.	Replace the transformer.
		No spark or weak spark	Properly ground the transformer case.
Burner Motor	Motor does not come up to speed and trips out on overload. Turn off power and rotate blower wheel by hand to check for binding or excessive drag.	Low line voltage	Check voltage at power source. Correct cause of voltage drop or the call power company.
		Pump or blower overloading motor	Correct cause of overloading.
		Faulty motor	Replace motor.

Troubleshooting: Burner starts and fires, but lock out on safety.

Source	Procedure		Causes	Correction
Poor Fire	After burner fires, immediately jumper across flame detector terminals at the primary control.	If burner continues to run, this may be due to poor fire. Inspect fire.	Unbalanced fire	Replace nozzle
			Too much air - -lean short fire	Reduce combustion air - check combustion.
			Too little air - - long dirty fire	Increase combustion air - check combustion.
			Excessive draft	Adjust barometric damper for correct draft.
			Too little draft or restriction	Correct draft or remove restriction.
Flame Detector	If fire is good, fault is in the flame detector. Check detector circuit.	Dirty cad cell face	Clean cad cell face.	
		Faulty cad cell - exceeds 15000 hms	Replace cad cell.	
		Loose or defective cad cell wires	Secure connections or replace cad cell holder and wire leads.	
Primary Control	If burner locks out on safety, fault is in the primary control.	Primary control circuit defective	Replace primary control.	

Troubleshooting: Burner Starts and Fires, but Loses Flame and Lock Out on Safety

Source	Procedure		Causes	Correction
Poor Fire	After burner fires, immediately jumper across flame detector terminals at the primary control.	If burner continues to run (does not lock out of safety), fault may be due to poor fire. Inspect fire.	Unbalanced fire	Replace nozzle
			Too much air - - lean short fire	Reduce combustion air - check combustion.
			Too little air - - long dirty fire	Increase combustion air - check combustion.
			Excessive draft	Adjust barometric damper for correct draft.
			Too little draft or restriction	Correct draft or remove restriction.
Flame Detector	If fire is good, fault is in the flame detector. Check detector circuit.	Dirty CAD cell face	Clean CAD cell face.	
		Faulty CAD cell - - exceeds 15000 hms	Replace CAD cell.	
		Loose or defective cad cell wires	Secure connections or replace cad cell holder and wire leads.	
Oil Supply	If burner loses flame (does not lock out on safety), fault is in the fuel system.	Pump loses prime - air slug	Prime pump at bleed port	
		Pump loses prime - air leak in supply line	Check supply line for loose connections and tighten fittings.	
		Water slug in line	Check oil tank for water (over 1 inch) pump or drain out water.	
	Listen for pump whine	Partially plugged nozzle or nozzle strainer	Replace nozzle.	
		Restriction in oil line	Clear restriction.	
		Plugged fuel pump strainer	Clean strainer or replace pump.	
		Cold oil - outdoor tank	Change to number 1 oil.	

Troubleshooting: Burner starts and fires, but short cycles (too little heat)

Source	Procedure	Causes	Correction
Thermostat	Check thermostat.	Heat anticipator set too low	Correct heat anticipator setting.
		Vibration at thermostat	Correct source of vibration.
		Thermostat in the path of a warm air draft	Shield thermostat from draft or relocate.
Limit Control	Connect voltmeter between line voltage connections to primary control (black & white leads). If burner cycles due to power interruption, it is cycling on limit.	Dirty furnace air filters	Clean or replace filter.
		Burner running too slow	Increase blower speed to maintain proper temp. rise.
		Blower motor seized or burned out	Replace motor.
		Blower bearings seized	Replace bearings and shaft.
		Blower wheel dirty	Clean blower wheel.
		Blower wheel in backward	Reverse blower wheel.
		Wrong motor rotation	Replace with properly rotating wheel.
		Restrictions in return or supply air system	Correct cause of restriction.
Power	If voltage fluctuates, fault is in the power source. Recheck voltage at the power source.	Loose wiring connection	Locate and secure connection.
		Low or fluctuating line voltage	Call power company.

Troubleshooting: Burner runs continuously (too much heat).

Source	Procedure		Causes	Correction
Thermostat	Disconnect thermostat wires at the primary control.	If burner turns off, fault is in the thermostat circuit.	Shorted or welded thermostat contacts	Repair or replace the thermostat.
			Stuck thermostat bimetal	Clear obstruction or replace thermostat.
			Thermostat not level	Level thermostat.
			Shorted thermostat wires	Repair short or replace wires.
			Thermostat out of calibration	Replace thermostat.
			Thermostat in cold draft	Correct draft or relocate the thermostat.
Primary control		If burner does not turn off, fault is in the primary control.	Defective primary control	Replace the defective primary control.

Troubleshooting: Burner runs continuously (too little heat).

Source	Procedure		Causes	Correction
Combustion	Check burner combustion for CO ₂ , stack temperature, and smoke	Low CO ₂ less than 10%.	Too much combustion air	Reduce combustion air.
			Air leaks into heat exchanger around inspection door, etc.	Correct cause of air leak.
			Excessive draft	Adjust barometric draft control for correct draft.
			Incorrect burner head adjustment	Correct burner head setting.
		High smoke reading more than a trace.	Dirty or plugged heat exchanger	Clean heat exchanger.
				Readjust burner.
			Insufficient draft	Increase draft.
			Incorrect burner head adjustment	Correct burner setting.
		High stack temperature is more than 550°F Net.	Too little combustion air	Increase combustion air.
			Too little blower air	Increase blower speed to maintain proper temp. rise.
			Blower belt too loose (if equipped)	Tighten blower belt.
			Dirty or plugged heat exchanger	Clean heat exchanger.
			Dirty blower wheel	Clean blower wheel.
Dirty furnace air filters	Clean or replace filter.			
Restricted or closed registers or dampers	Readjust registers or dampers.			
Oil Pressure	Inspect fire and check oil pressure.		Partially plugged or defective nozzle	Replace nozzle.
			Oil pressure is too low: less than 100 psi.	Increase oil pressure top 100psi.