

**SERVICE****UNIT  
INFORMATION****HS18****LENNOX** Industries Inc.

Corp. 839-L2

Litho U.S.A.

**HS18 SERIES CONDENSING UNITS  
(211, 261, 311 & 411)****I - INTRODUCTION**

The HS18 was introduced in 1982. It is a high efficiency unit in 4 sizes, 1-1/2 through 3 ton. Units have increased coil surface area, a four sided wrap-around coil which provides maximum cooling efficiency and heat transfer with minimum air resistance.

The unit is used with either RFCII or expansion valve systems. Expansion valve kit information is available in the evaporator section of the Engineering Handbook. Hard start kits are not necessarily needed; however, kits are available and information can be found in the "Cross Reference Section" of the Repair Parts Microfiche. 1, 3-1/2, 4 & 5 ton units and three phase models will become available throughout 1983.

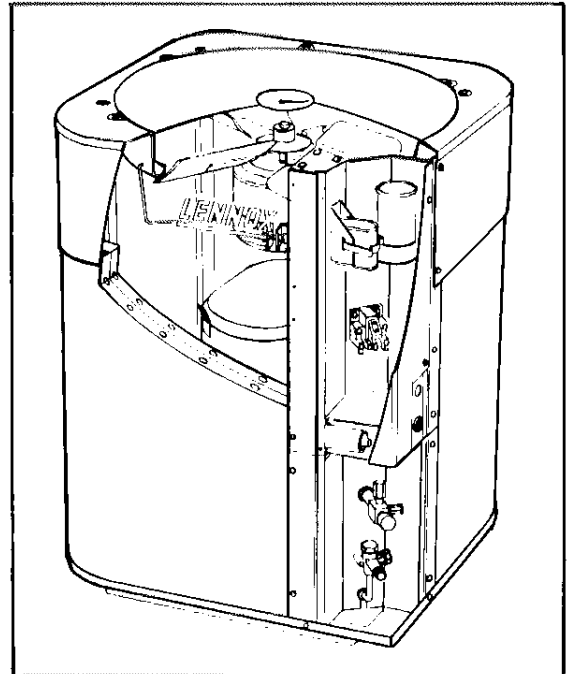
**II - UNIT INFORMATION****A - Specifications**

Model No.		HS18-211	HS18-261	HS18-311	HS18-411	
Condenser Coil	Net face area (sq. ft.)	Outer coil	9.2	9.2	9.2	9.2
		Inner coil	---	---	3.4	5.1
	Tube diameter (in.) & No. of rows	3/8 - 1	3/8 - 1	3/8 - 1.37	3/8 - 1.56	
	Fins per inch	20	20	20	20	
Condenser Fan	Diameter (in.) & No. of blades		18 4	18 4	18 4	18 - 4
	Motor hp		1/6	1/6	1/6	1/6
	Cfm (factory setting)		2600	2600	2500	2500
	Rpm (factory setting)		1060	1060	1050	1050
	Watts (factory setting)		250	250	260	260
*Refrigerant - 22 charge furnished		3 lbs. 7 oz.	3 lbs. 14 oz.	5 lbs. 3 oz.	5 lbs. 14 oz.	
Liquid line (o.d. in.) connection (sweat)		3/8	3/8	3/8	3/8	
Suction line (o.d. in.) connection (sweat)		5/8	5/8	3/4	3/4	
Shipping weight (lbs.) 1 Package		130	140	145	167	

\*Refrigerant charge sufficient for 25 ft. length of refrigerant lines.

**B - Electrical Data**

Model No.		HS18-211	HS18-261	HS18-311	HS18-411
Line voltage data (60 hz - 1 phase)		208/230V	208/230V	208/230V	208/230V
Compressor	Rated load amps	8.7	12.1	14.0	17.6
	Power factor	.95	.98	.97	.98
	Locked rotor amps	49.0	59.0	81.0	88.0
Condenser Coil Fan Motor	Full load amps	1.2	1.2	1.2	1.2
	Locked rotor amps	2.2	2.2	2.2	2.2
Recommended maximum fuse size (amps)		20.0	25.0	30.0	40.0
*Minimum circuit ampacity		12.1	16.3	18.7	23.2

\*Refer to National Electrical Code manual to determine wire, fuse and disconnect size requirements.

NOTE - Extremes of operating range are plus and minus 10% of line voltage.

## C - Pressure Curves

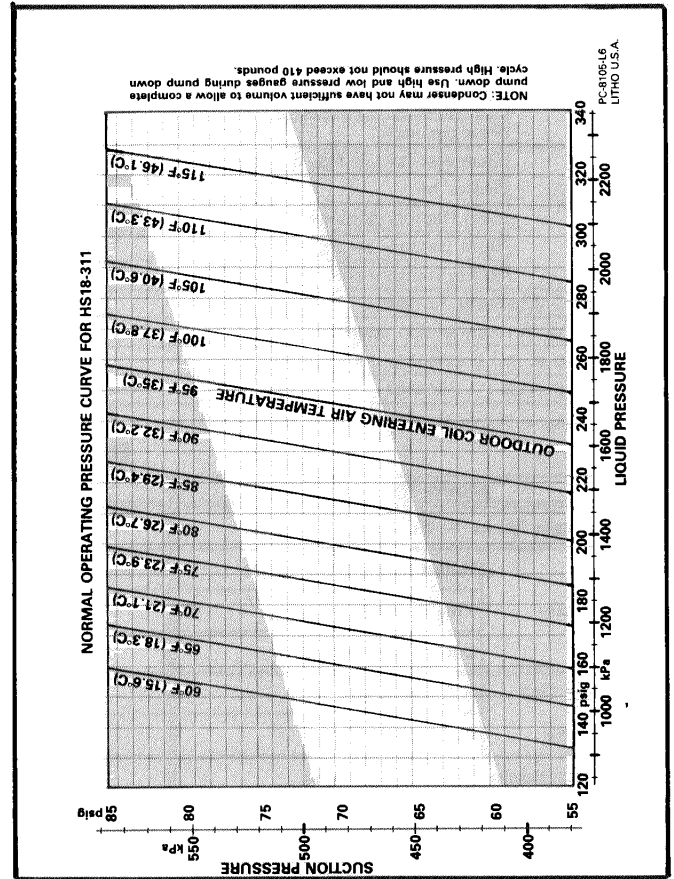
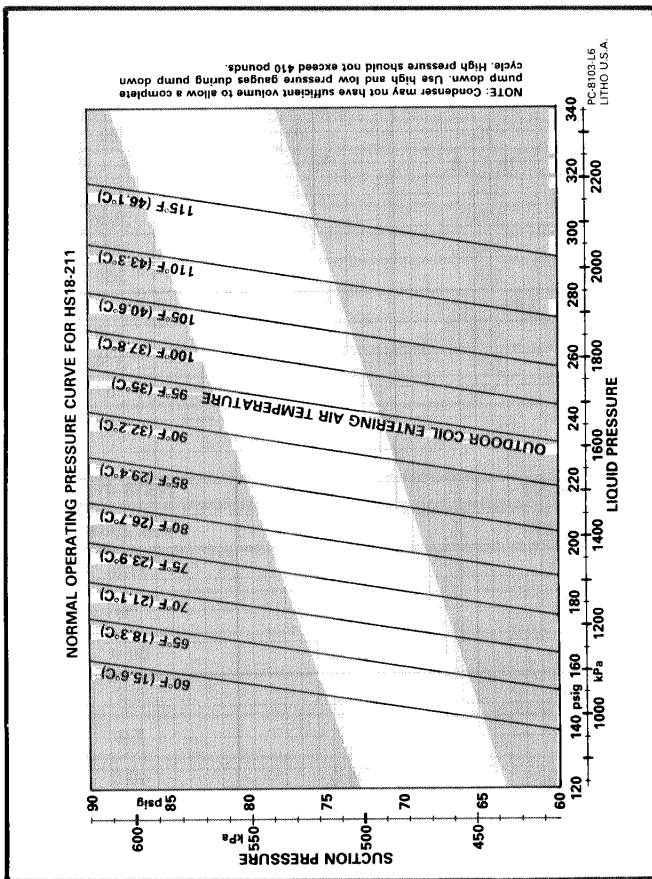
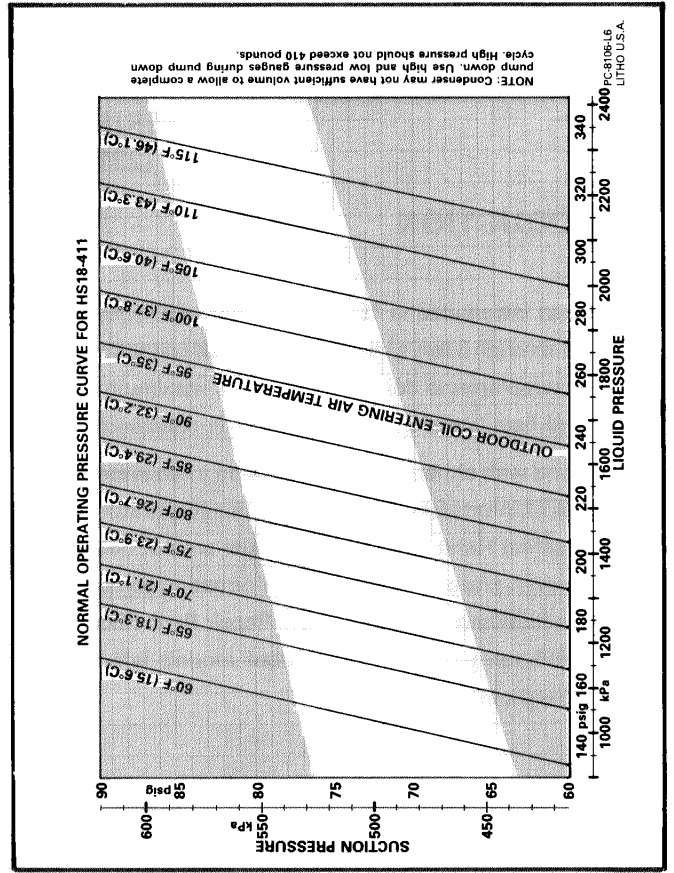
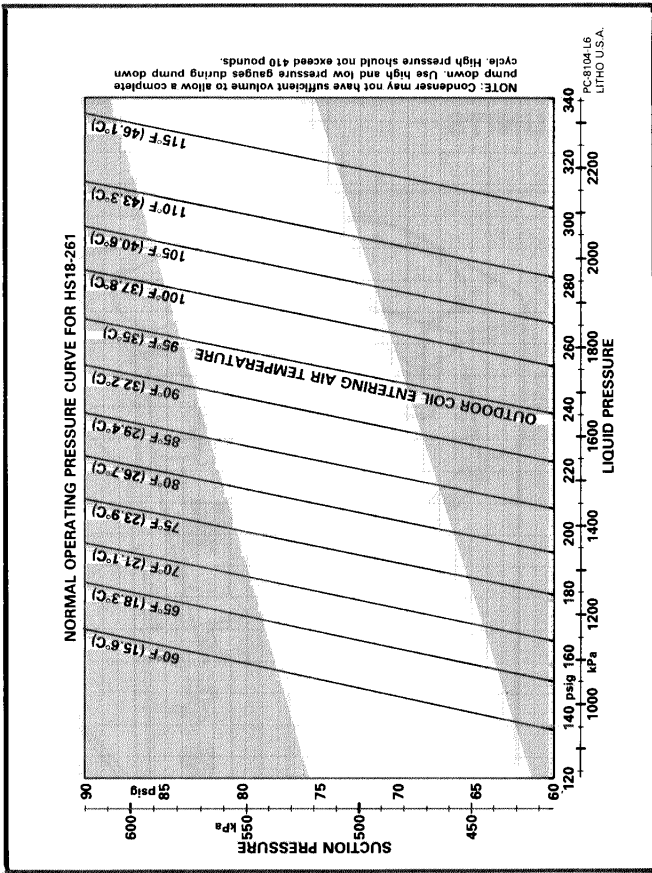

## C - Pressure Curves

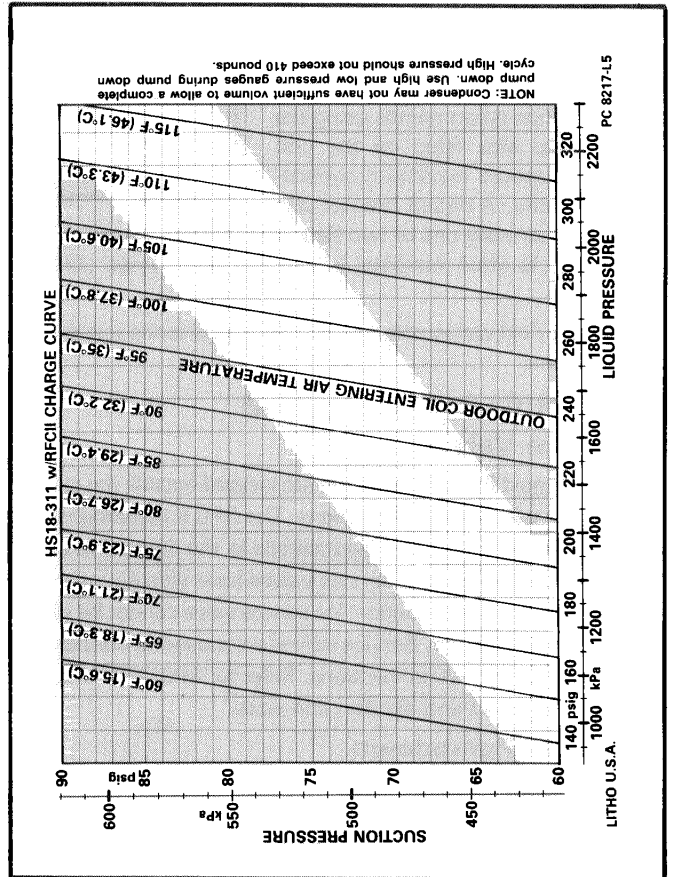
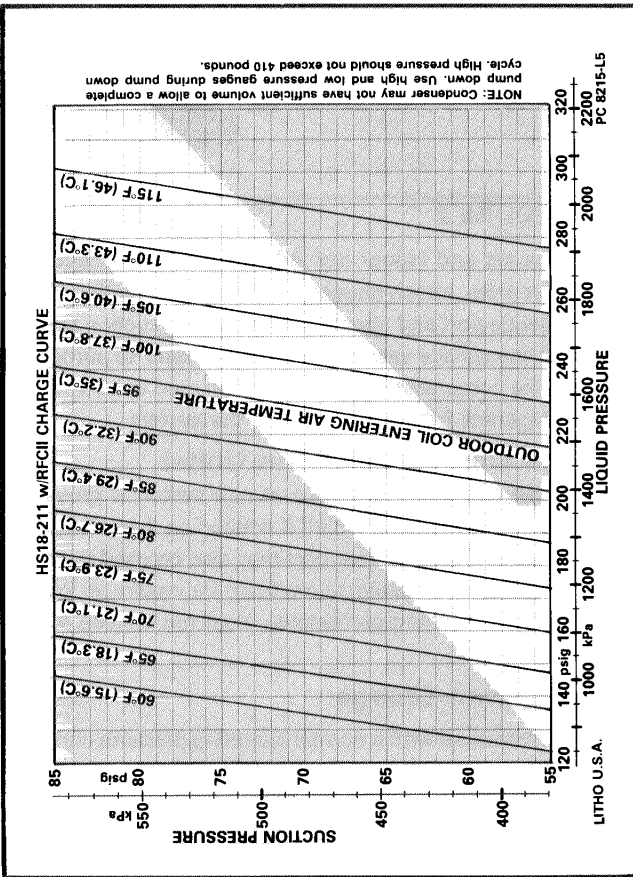
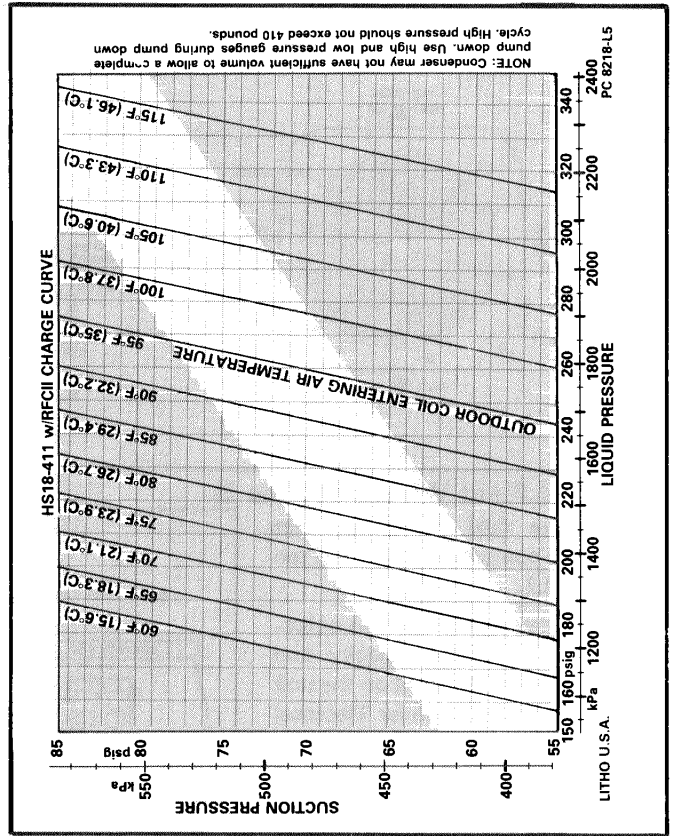
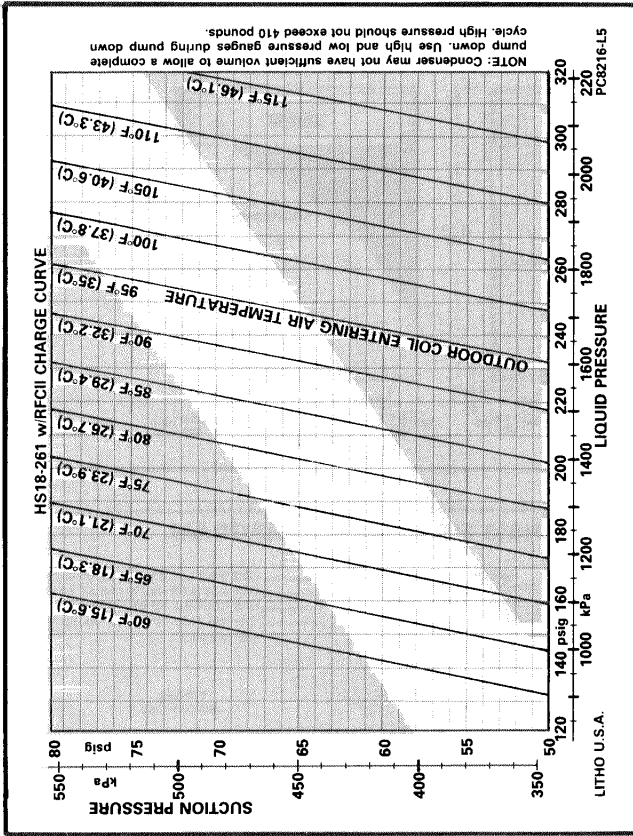

## D - Unit Dimensions

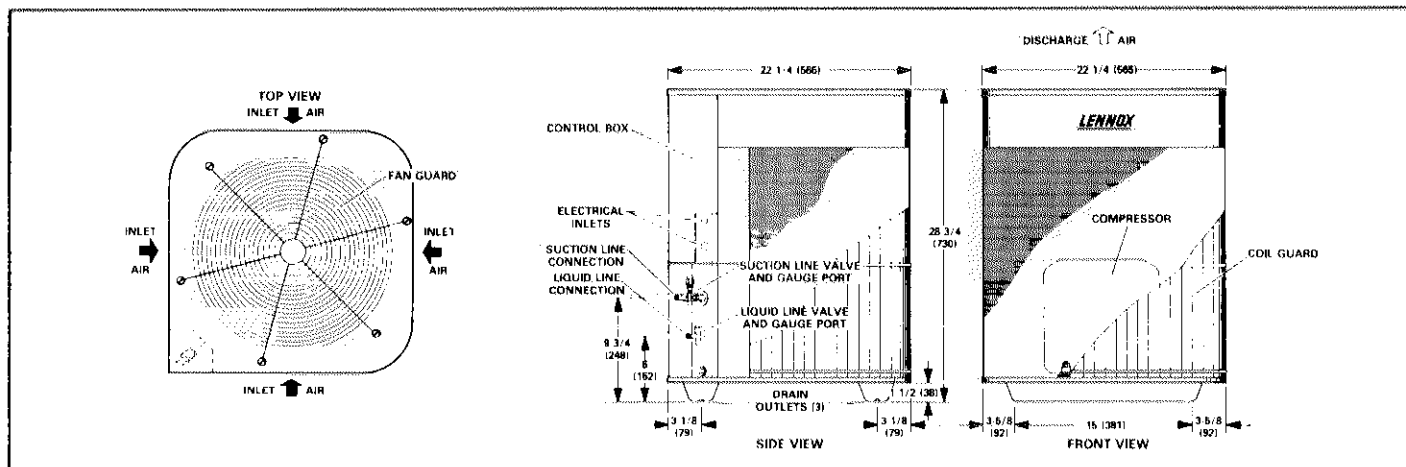

FIGURE 1

## E - Typical Field Wiring (Figure 2)

High voltage field wiring connects directly to the compressor contactor terminals L1 & L2.

**Note on unit wire size & fuse selection** - Minimum circuit ampacity and maximum fuse size are listed on the unit nameplate (also on pg.1 under 'Electrical Data' of this manual and in the Engineering Handbook). The unit supply wire size must be obtained from the appropriate Table 310 of the National Electric Code. Sometimes nuisance tripouts occur to circuit breakers that may be in the branch circuit. This condition is usually encountered when the circuit breaker is sized to the equipment's minimum circuit ampacity (MCA) instead of the maximum fuse size. Lennox recommends using the maximum fuse size listed on the unit nameplate to assure maximum current-carrying capacity. A circuit breaker size from MCA is normally one of two sizes smaller than the maximum fuse size and is often marginal in carrying the normal starting current.

**Low voltage** field wiring connects to the pigtail leads just below the control box.

## III - REFRIGERANT SYSTEM

### A - Service Valves

Suction and liquid line service valves are located outside the cabinet and are made with sweat connections. The RFC II metering device is furnished as standard and field installs in the liquid line at the evaporator coil. All external service valves have side gauge ports, Figure 1. The "one shot" suction line service valve cannot be closed once it has been opened. Service valves are closed to condensing unit and open to line set connections. Refer to 'SPECIFICATIONS' on Page 1 for liquid and suction line sizes.

### B - System Pumpdown

The liquid and suction service valves and gauge ports are accessible from outside of the unit. The "one shot" suction line service valve cannot be closed once it has been opened. The gauge ports are used for leak testing, evacuating, charging and checking charge.

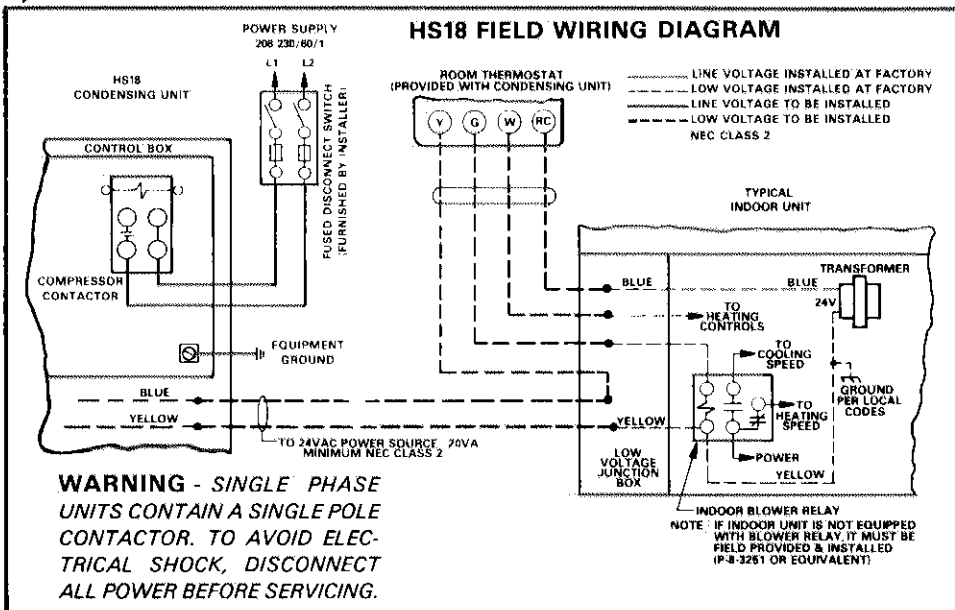

FIGURE 2

To open line set and indoor coil side for service procedures on 1-1/2 - 3 ton units, attach gauge manifold to the suction line service valve gauge port and open manifold to read suction pressure. Close liquid line service valve and run compressor to pump down to 0 psig. The compressor contains suction reed valve which will prevent refrigerant from releasing into the system.

### C - Liquid Line Port (4-5 Ton Units)

A port for the addition of a high pressure switch is provided in the liquid line for a low ambient kit if needed on 4 and 5 ton units soon to become available. This port may also be used to monitor high pressure during a system pumpdown for repairs on low side. The high pressure during pumpdown must not exceed 410 psig (2827 kPa).

### D - Refrigerant Charge

Each unit is furnished with a normal operating pressure curve. The curve uses suction pressure, liquid pressure, and outdoor temperature comparison. To use the chart, first check suction pressure, then move over to the outdoor temperature and finally down to the liquid pressure. If the liquid pressure is within five

pounds of this reading, the unit is properly charged, providing the three conditions meet in the unshaded area of the chart. If they meet in the shaded area, there is something wrong with the system and further checks are needed.

## IV - Components (Figure 3)

### A - Control Box

#### 1 - Compressor Contactor

Units are single phase and use a 1 pole N.O. contactor with a 24 volt coil to operate compressor and condenser fan.

Alternate contactors may be used having the N.O. pole on either the L1 or L2 line side. This can place the unswitched line side on either the common or run side of the compressor circuit, depending on the contactor used.

**CAUTION** - The single pole contactor on 208-230V single phase units, although not new to the industry, is new to Lennox condensing units. With the disconnect closed, one side is 'hot' throughout the unit. TO AVOID ELECTRICAL SHOCK, DISCONNECT ALL POWER TO UNIT BEFORE SERVICING.

#### 3 - Fan Motor Capacitor

Condenser fan motor capacitor: (located next to control box)

211, 261, 311 & 411 Units - 5 mfd, 370 VAC

#### 4 - Compressor Run Capacitor

The compressor run capacitor is located next to the fan motor capacitor. Values are as follows

211 Unit - 20 mfd, 370 VAC

261 & 311 Units - 35 mfd, 370 VAC

411 Unit - 40 mfd, 370 VAC

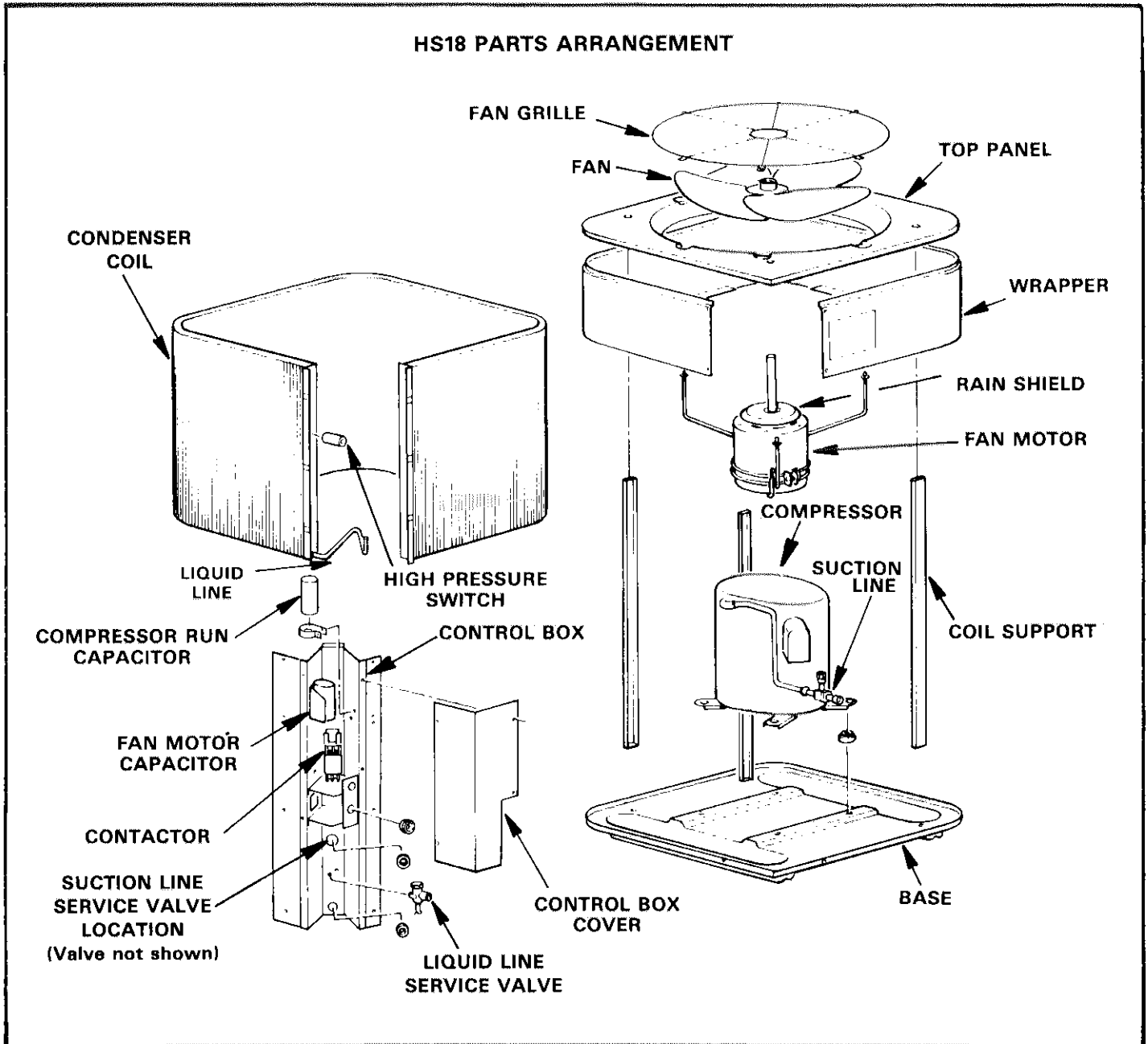

FIGURE 3

## B - Compressor Compartment

Compressor service access is obtained by removing four screws on top of unit and three screws located on sides of cabinet. Entire top of unit with fan guard, fan and motor may be lifted off for compressor access. Fan motor leads have sufficient length to remain attached.

### 1 - High Pressure Switch

Switch is located on a condenser coil return bend and cuts out at 410 psig. Must be manually reset below 180 psig.

### 2 - Compressor

The compressors in the HS18 series incorporate internal line break overloads and internal pressure relief valve. The 211, 311 & 411 units use Tecumseh compressors and the 261 unit uses a Copeland compressor. Compressor oil requirements:

211 & 311 Units - 32 ounces

261 Unit - 55 ounces mineral oil (viscosity 190 - 210)

411 Unit - 54 ounces

### 3 - Crankcase Heaters (Optional)

A wrap around type crankcase heater is available for HS18 com-

pressors. Crankcase heater is 45W, 240VAC and is energized anytime power is on to the HS18 unit. Order crankcase heater through Repair Parts P-8-8852.

## C - Condenser Coil Compartment

The unit utilizes a draw through coil with vertical discharge. Fan motors are 1/6 hp, 1075 rpm, 208 - 230 V, 60 hz - single phase and prelubricated at the factory, however check motor for the particular lubrication requirements. For fan access, remove the fan guard. The motor has a rain shield for protection from moisture. Figure 4 illustrates the condenser fan and motor assembly.

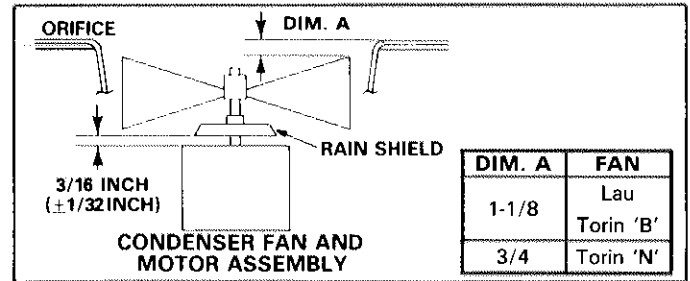

FIGURE 4

## V - SEQUENCE OF OPERATION (Figure 5)

Each of the steps within this section are labeled in the diagram

- 1 - Thermostat closes on a temperature rise to initiate a cooling demand through R1-Y1.

- 2 - Through thermostat switch (set to 'cool') and fan switch (set to 'auto') the blower relay is energized.

- 3 - The blower relay N.O. contacts close to energize the blower motor through the cooling speed tap.

- 4 - When the thermostat closes it also completes a circuit through the high pressure switch to energize the compressor contactor coil.

- 5 - The compressor contactor contacts close to energize the compressor motor. The start capacitor is connected in parallel with the run capacitor through the potential relay N.C. contacts. When the compressor comes up to speed, the potential relay coil is energized opening its' N.C. contacts to disconnect the start capacitor from the circuit.

- 6 - The compressor contactor also powers the condenser fan motor.

- 7 - When the demand is satisfied the thermostat contacts R1-Y1 open dropping out the compressor contactor.

- 8 - The optional crankcase heater is energized anytime the external disconnect is in the 'ON' position.

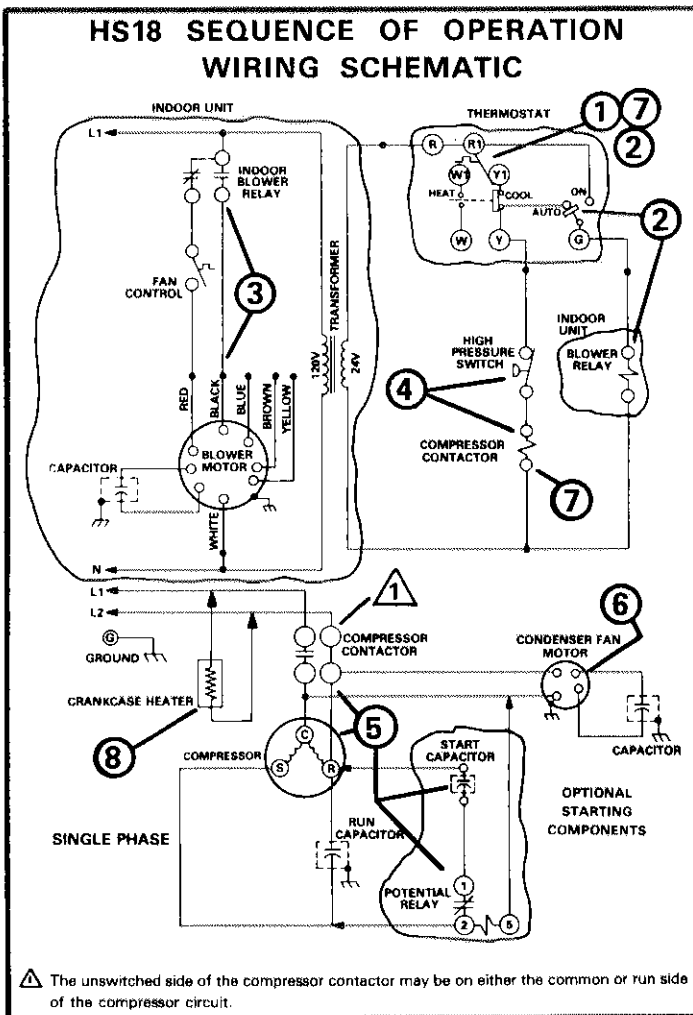

FIGURE 5