

INSTALLATION INSTRUCTIONS

RETAIN THESE INSTRUCTIONS FOR FUTURE REFERENCE

⚠ WARNING

Improper installation, adjustment, alteration, service or maintenance can cause property damage, personal injury or loss of life. Installation and service must be performed by a qualified installer, service agency or the gas supplier

LGA/LCA248H (21 TON)

LGC/LCC300H (25 TON)

LGA/LCA360H (30 TON)

L SERIES PACKAGED UNITS

504,819M
10/2003
Supersedes 9/2003

Table Of Contents

Dimensions	1	Pressure Test Gas Piping	5
Shipping and Packing List	2	Factory-Installed Options	5
General	2	Electrical Connections	7
Requirements	2	Blower Operation and Adjustments	8
Unit Support	2	Cooling Start-Up	11
Duct Connection	3	Gas Heat Start-Up	16
Rigging Unit For Lifting	3	Heating Operation and Adjustments	17
Condensate Drains	4	Electric Heat Start-Up	18
Gas Piping	4	Service	18

LGA/LCA/LGC/LCC248, 300 & 360 Parts Arrangement

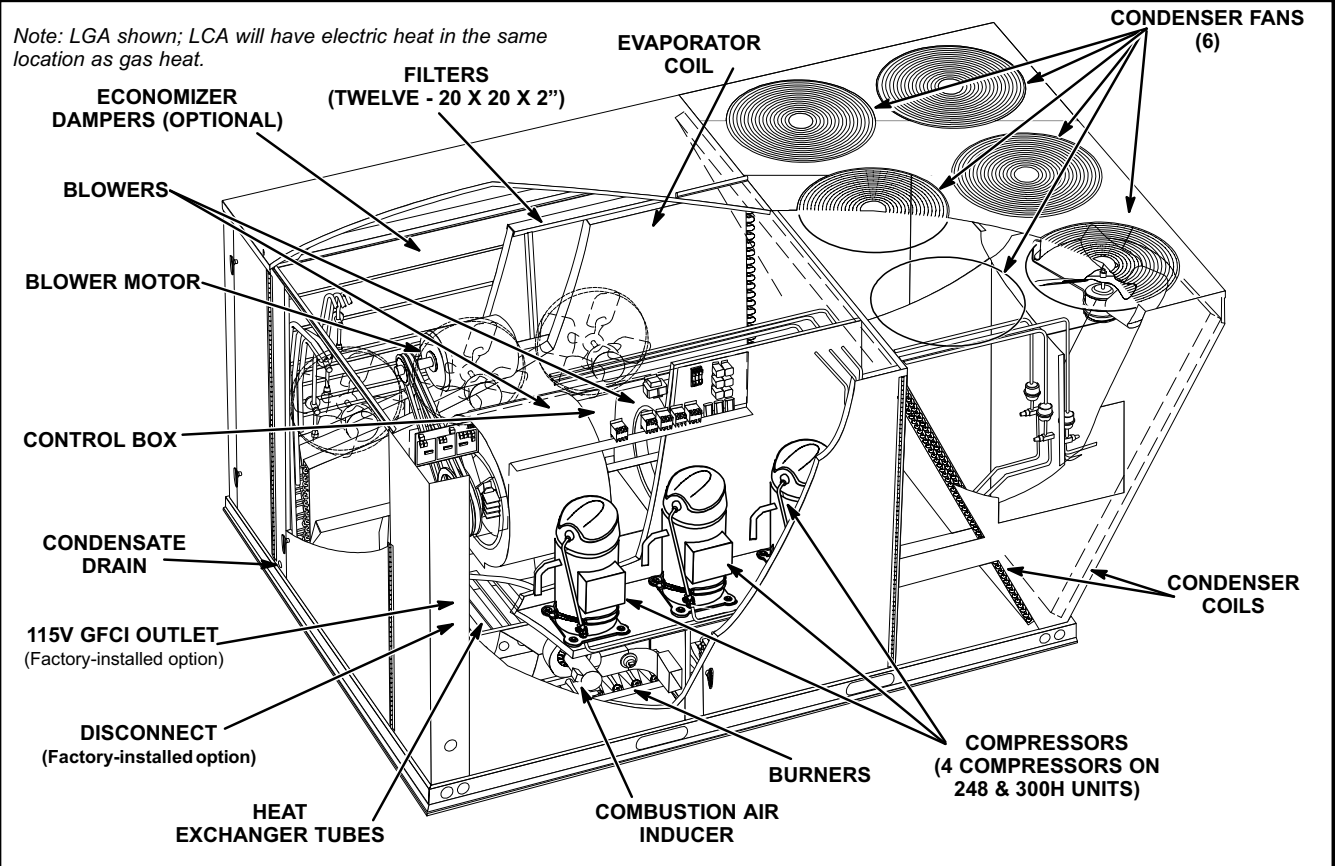

10/03

504,819M



LGA/LCA/LGC/LCC248, 300 & 360 Dimensions - LGA Heat Section Shown

Note: Optional equipment shown for information only. See Engineering Handbook for standard and optional features.

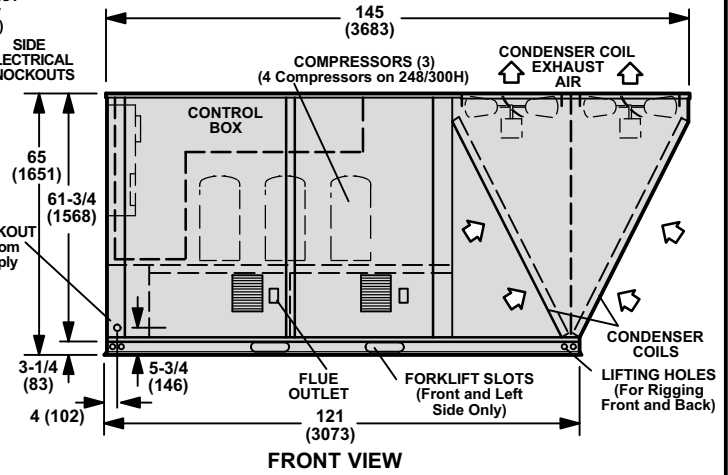
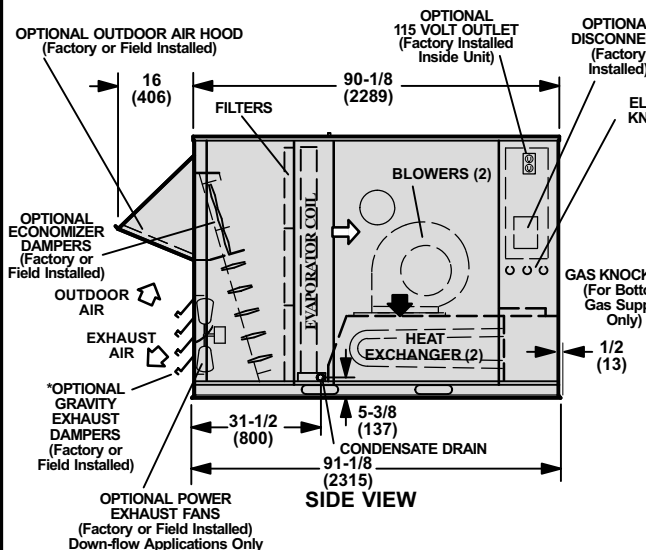
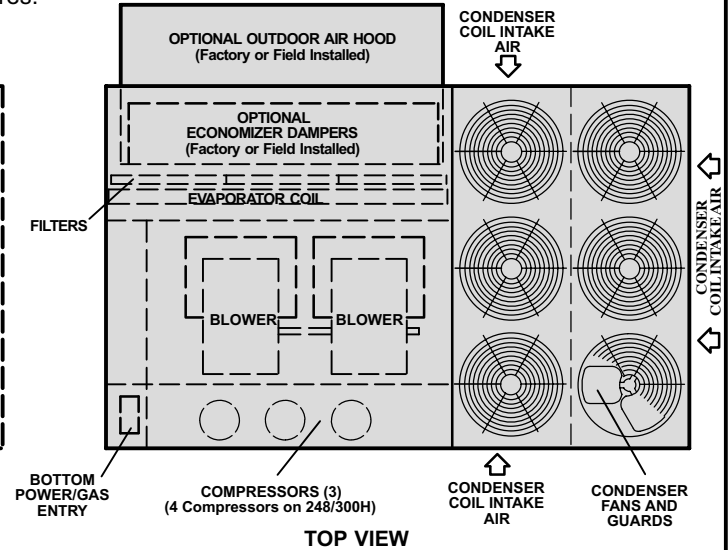
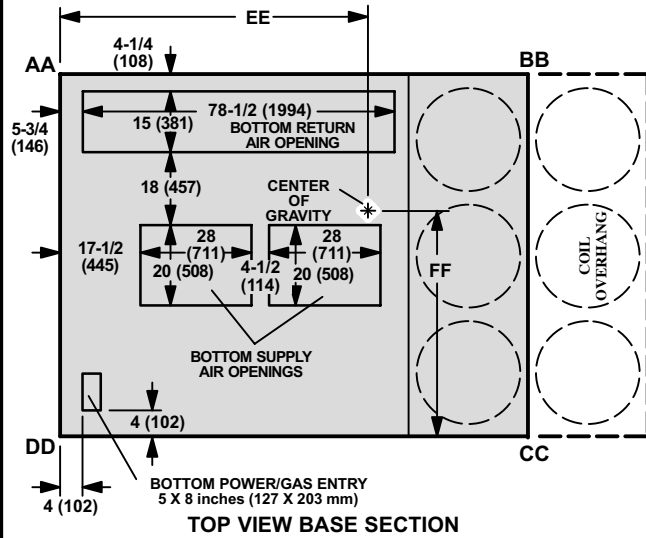

*NOTE — Field Installed in Return Air Duct for Horizontal Applications.

91 (2311) LARMFH30/36-30
102 (2591) LARMFH30/36-41

**NOTE — Top of Mounting Frame extends 4 inch (102 mm) inside bottom of unit base. See Typical Flashing Detail.

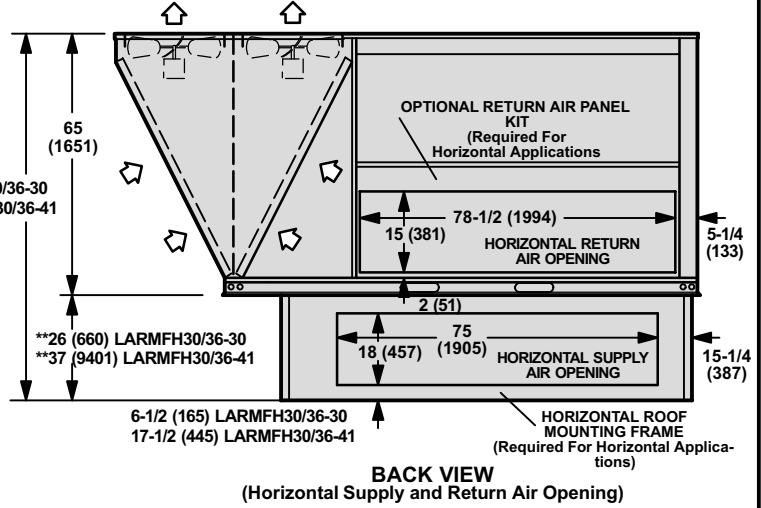

Shipping and Packing List

Package 1 of 1 contains:

1- Assembled unit

Check unit for shipping damage. Receiving party should contact last carrier immediately if shipping damage is found.

General

These instructions are intended as a general guide and do not supersede local codes in any way. Authorities having jurisdiction should be consulted before installation.

The LGA/LGC248, 300 & 360 gas/electric packaged rooftop units are available in 260,000 Btuh or 470,000 Btuh heating inputs. The LCA/LCC248, 300, & 360 cooling packaged rooftop unit is the same basic design as the LGA/LGC unit except for the heating section. Optional electric heat is factory- or field-installed in LCA/LCC units. LGA/LGC and LCA/LCC units have identical refrigerant circuits with respective 21, 25, and 30 ton cooling capacities. LGA/LCA248H and LGC/LCC300H units contain four compressors; LGA/LCA360H units contain three compressors.

LGA/LCA248 and 360 units are available using R410A, an ozone-friendly HFC refrigerant. Refer to the Cooling Start-Up section for precautions when installing unit.

Requirements

See figure 1 for unit clearances.

NOTE - These units must not be used as a "construction heater" at any time during any phase of construction. Very low return air temperatures, harmful vapors, and misplacement of the filters will damage the unit and its efficiency.

⚠ WARNING



Electric shock hazard and danger of explosion. Can cause injury, death or product or property damage. Turn off gas and electrical power to unit before performing any maintenance or servicing operations on the unit. Follow lighting instructions attached to unit when putting unit back into operation and after service or maintenance.

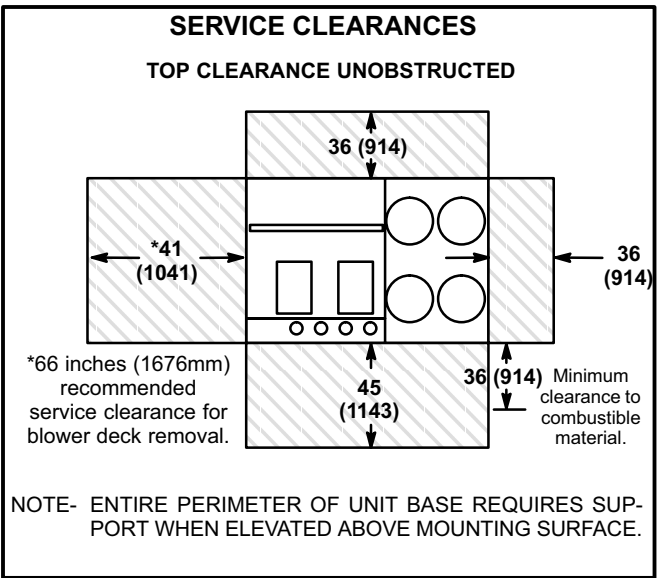

FIGURE 1

⚠ IMPORTANT

The Clean Air Act of 1990 bans the intentional venting of refrigerant (CFC's and HCFC's) as of July 1, 1992. Approved methods of recovery, recycling or reclaiming must be followed. Fines and/or incarceration may be levied for non-compliance.

⚠ CAUTION

Danger of sharp metallic edges. Can cause injury. Take care when servicing unit to avoid accidental contact with sharp edges.

Unit Support

In downflow discharge installations, install the unit on a non-combustible surface only. Unit may be installed on combustible surfaces when used in horizontal discharge applications or in downflow discharge applications when installed on an LARMF18/36 roof mounting frame.

NOTE - Securely fasten roof frame to roof per local codes.

A-Downflow Discharge Application

Roof Mounting with LARMF18/36

- 1- The LARMF roof mounting frame must be installed, flashed and sealed in accordance with the instructions provided with the frame.
- 2- The LARMF roof mounting frame should be square and level to 1/16" per linear foot (5mm per linear meter) in any direction.
- 3- Duct must be attached to the roof mounting frame and not to the unit; supply and return plenums must be installed before setting the unit.

Unit Support - Continued

Installer's Roof Mounting Frame

Many types of roof frames can be used to install the unit depending upon different roof structures. Items to keep in mind when using the building frame or supports are:

- 1- The base is fully enclosed and insulated, so an enclosed frame is not required.
- 2- The frames or supports must be constructed with non-combustible materials and should be square and level to 1/16" per linear foot (5mm per linear meter) in any direction.
- 3- Frame or supports must be high enough to prevent any form of moisture from entering unit. Recommended minimum frame height is 14" (356mm).
- 4- Duct must be attached to the roof mounting frame and not to the unit. Supply and return plenums must be installed before setting the unit.
- 5- Units require support along all four sides of unit base. Supports must be constructed of steel or suitably treated wood materials.

NOTE-When installing a unit on a combustible surface for downflow discharge applications, an LARMF18/36 roof mounting frame is required.

B-Horizontal Discharge Applications

- 1- Units installed in horizontal airflow applications must use an LARMFH30/36 horizontal roof mounting frame. The supply air duct connects to the horizontal supply air opening on the LARMFH30/36. The return air duct connects to the unit horizontal return air opening. Refer to unit dimensions.
- 2- Specified installation clearances must be maintained when installing units. Refer to figure 1.
- 3- Top of support slab should be approximately 4" (102mm) above the finished grade and located so no run-off water from higher ground can collect around the unit.
- 4- Units require support along all four sides of unit base. Supports must be constructed of steel or suitably treated wood materials.

Duct Connection

All exterior ducts, joints and openings in roof or building walls must be insulated and weather-proofed with flashing and sealing compounds in accordance with applicable codes. Any duct passing through an unconditioned space must be insulated.

⚠ CAUTION

In downflow applications, do not drill or punch holes in base of unit. Leaking in roof may occur if unit base is punctured.

Rigging Unit For Lifting

Rig unit for lifting by attaching four cables to holes in unit base rail. See figure 2.

- 1- Detach wooden base protection before rigging.
- 2- Connect rigging to the unit base using both holes in each corner.
- 3- All panels must be in place for rigging.
- 4- Place field-provided H-style pick in place just above top edge of unit. Frame must be of adequate strength and length. (H-style pick prevents damage to top of unit.)

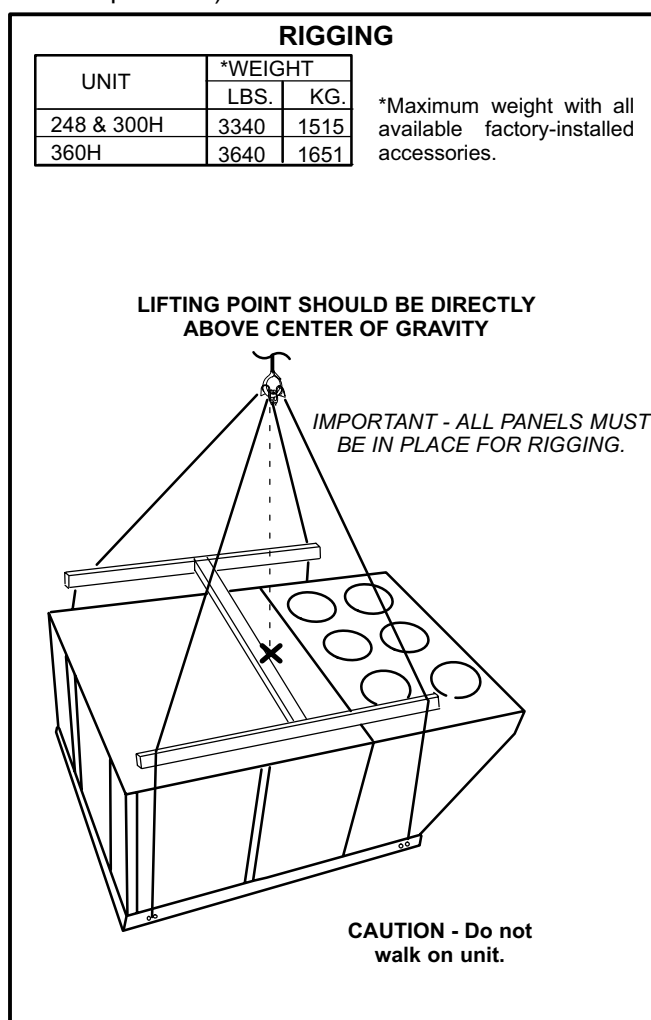

FIGURE 2

Condensate Drains

Make drain connection to the 1" N.P.T. drain coupling provided on unit. A trap must be installed between drain connection and an open vent for proper condensate removal. See figure 3. It is sometimes acceptable to drain condensate onto the roof or grade; however, a tee should be fitted to the trap to direct condensate downward. The condensate line must be vented. Check local codes concerning condensate disposal. Refer to pages 1 and 2 for condensate drain location.

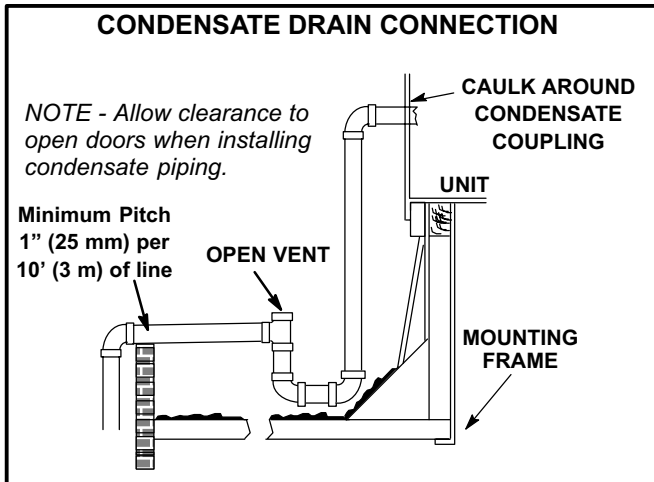

FIGURE 3

Connect Gas Piping (Gas Units)

Before connecting piping, check with gas company or authorities having jurisdiction for local code requirements. When installing gas supply piping, length of run from gas meter must be considered in determining pipe size for 0.5" w.c. (.12kPa) maximum pressure drop. Do not use supply pipe smaller than unit gas connection. For natural gas units, operating pressure at the unit gas connection must be a minimum of 4.7" w.c. (1.17kPa) and a maximum of 10.5" (2.60kPa) w.c. For LP/propane gas units, operating pressure at the unit gas connection must be a minimum of 11" w.c. (2.74kPa) and a maximum of 13.5" w.c. (3.36kPa).

When making piping connections a drip leg should be installed on vertical pipe runs to serve as a trap for sediment or condensate. A 1/8" N.P.T. plugged tap is located on gas valve for test gauge connection. Refer to Heating Start-Up section for tap location. Install a ground joint union between the gas control manifold and the main manual shut-off valve. See figure 4 for gas supply piping entering outside the unit. Adapt existing piping as shown in figure 5 for bottom gas entry. Figure 6 shows complete bottom gas entry piping.

Compounds used on threaded joints of gas piping shall be resistant to the action of liquified petroleum gases.

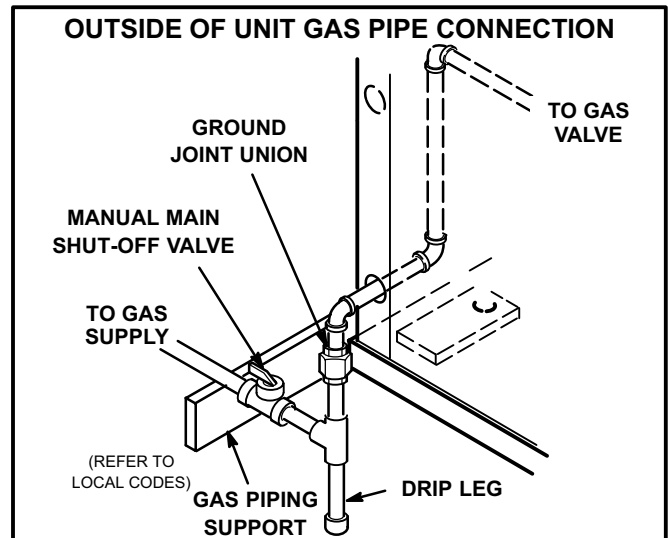

FIGURE 4

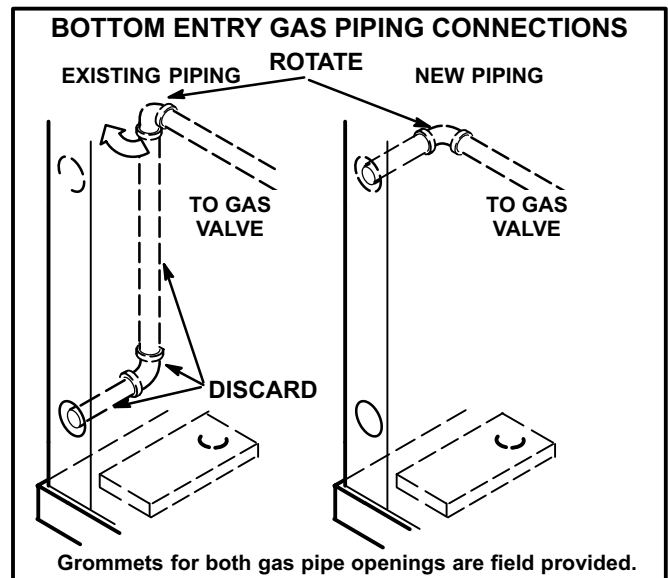

FIGURE 5

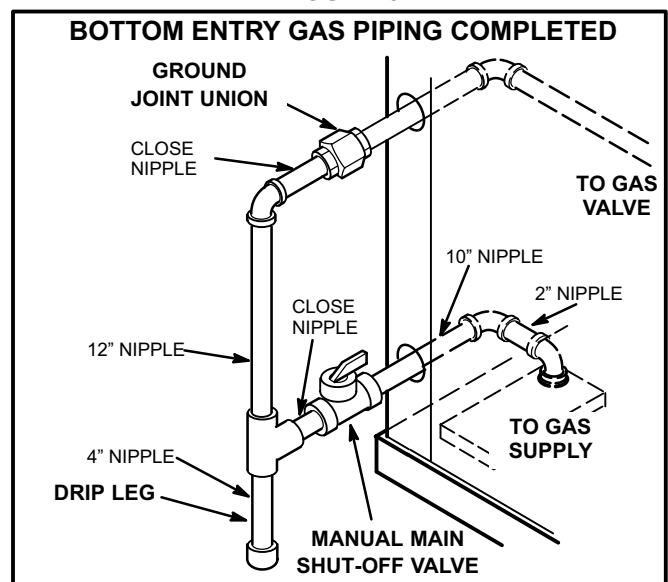

FIGURE 6

Pressure Test Gas Piping (Gas Units)

When pressure testing gas lines, the gas valve must be disconnected and isolated. Gas valves can be damaged if subjected to more than 0.5 psig (3.5kPa). See figure 7.

NOTE-Codes may require that manual main shut-off valve and union (furnished by installer) be installed in gas line external to unit. Union must be of the ground joint type.

After all connections have been made, check all piping connections for gas leaks. Also check existing gas connections up to the gas valve; loosening may occur during installation. Use a soap solution or other preferred means. Do not use matches candles or other sources of ignition to check for gas leaks.

⚠ CAUTION

Some soaps used for leak detection are corrosive to certain metals. Carefully rinse piping thoroughly after leak test has been completed. Do not use matches, candles, flame or othe sources of ignition to check for gas leaks.

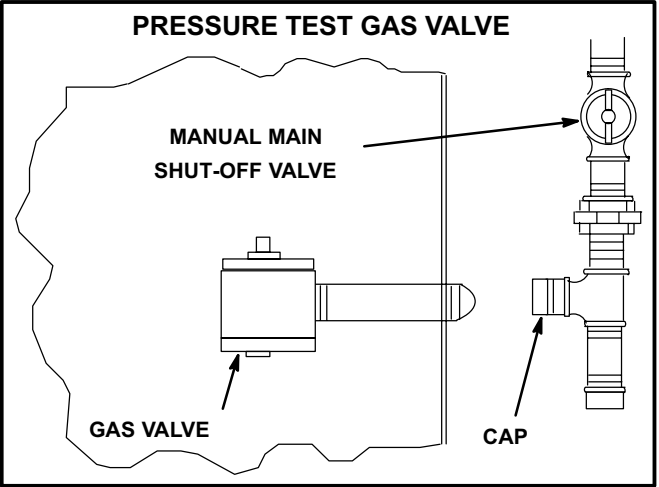

FIGURE 7

⚠ WARNING

Danger of explosion. Can cause injury or product or property damage. Do not use matches, candles, flame or other sources of ignition to check for leaks.

NOTE-In case emergency shut down is required, turn off the main manual shut-off valve and disconnect main power to unit. These devices should be properly labeled by the installer.

High Altitude Derate

Natural gas units may be installed at altitudes up to 2000 feet (610m) above sea level without any modification. At altitudes above 2000 feet (610 m), units must be derated to match gas manifold pressures shown in table 1.

NOTE-This is the only permissible derate for these units.

TABLE 1

Altitude - ft. (m)	Gas Manifold Pressure in. w.g. (kPa)	
	Natural	LP (Propane)
2001 - 3000 (610 - 915)	3.6 (0.90)	10.2 (2.54)
3001 - 4000 (915 - 1220)	3.5 (0.87)	9.9 (2.46)
4001 - 5000 (1220 - 1525)	3.4 (0.85)	9.6 (2.39)
5001 - 6000 (1525 - 1830)	3.3 (0.82)	9.4 (2.34)
6001 - 7000 (1830 - 2135)	3.2 (0.80)	9.1 (2.26)
7001 - 8000 (2135 - 2440)	3.1 (0.77)	8.8 (2.19)

Factory-Installed Options

A-Economizer

The A56 (EM1) economizer board controls economizer operation and provides potentiometers to control minimum damper position and enthalpy control adjustments. The economizer board is positioned on the A55 (M1) main control board in the unit control box. See the Integrated Modular Control Guide for economizer operation and adjustments.

B-Intake Hood

The intake hood top panel is secured to the unit. The intake hood sides, filters, stiffener, and three support brackets are shipped unassembled in the blower compartment. Assemble hoods and install as follows:

- 1- Remove screws securing side flanges of top hood to unit. See figure 8.
- 2- Pivot top hood open and secure sides of intake hood to top of hood using three sheet metal screws on each side. See figure 8.
- 3- Align two holes on intake hood side panel with two holes on bottom (longer) filter bracket. See figure 9. Secure both sides of bottom filter bracket to hood sides with sheet metal screws.
- 4- Secure intake hood sides to unit.
- 5- Align hood stiffener screw holes with hood top screw holes. Secure with sheet metal screws.
- 6- Secure the longer top filter bracket to top of hood as shown in figures 8 and 9. Install four filters.
- 7- Slide fifth filter into bottom filter bracket and hold in place at the top of the opening with the shorter filter bracket. Align holes on hood with bracket holes and secure filter bracket with sheet metal screws.

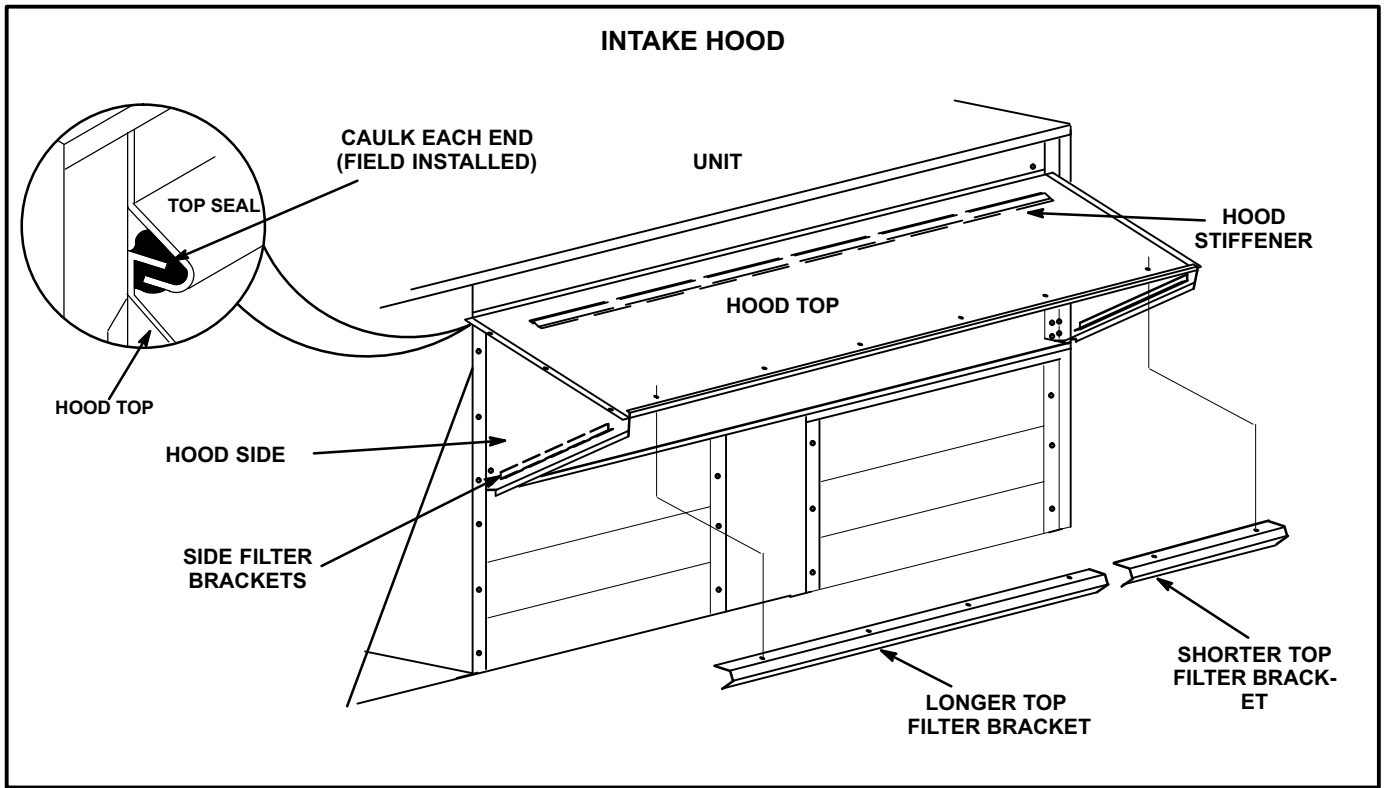

FIGURE 8

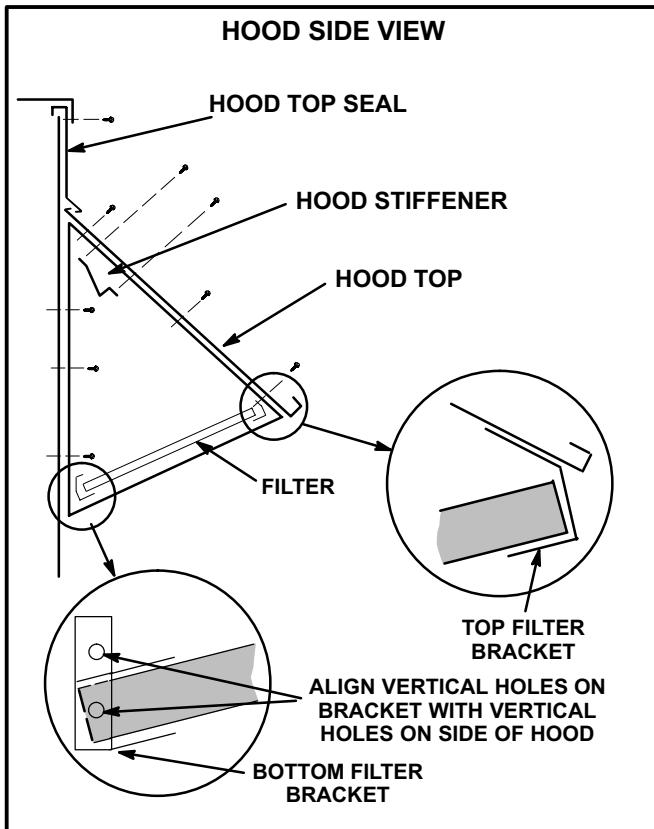

FIGURE 9

Electrical Connections

POWER SUPPLY

Do not apply power or close disconnect switch until installation is complete. Refer to start-up directions. Refer closely to unit wiring diagram.

Refer to unit nameplate for minimum circuit ampacity and maximum fuse size.

- 1- 230/460/575 volt units are factory wired. **For 208V supply**, disconnect the orange wire (230V) at control power transformer(s). Reconnect the red wire (208V). Tape the exposed end of the 230V orange wire.
- 2- Route power through the bottom power entry area and connect to line side of unit disconnect or circuit breaker. If unit does not contain optional controls package, connect power wiring to TB13 terminal block. See unit wiring diagram.
- 3- *Units With Optional 120v GFCI Outlet -*
Route and connect separate 120v wiring to GFCI outlets which do not have factory-installed wiring.

CONTROL WIRING

A-Thermostat Location

Room thermostat mounts vertically on a standard 2" X 4" handy box or on any non-conductive flat surface.

Locate thermostat approximately 5 feet (1524mm) above the floor in an area with good air circulation at average temperature. Avoid locating the room thermostat where it might be affected by:

- drafts or dead spots behind doors and in corners
- hot or cold air from ducts
- radiant heat from sun or appliances
- concealed pipes and chimneys

B-Control Wiring

- 1- Route thermostat cable or wires from subbase through knockout provided in unit. Use 18 AWG wire for all applications using remotely installed electro-mechanical and electronic thermostats.
- 2- Install thermostat assembly in accordance with instructions provided with thermostat. See figure 10 for field wiring electronic and electro-mechanical thermostats. If using other temperature control devices or energy management systems see instructions and wiring diagram provided by manufacturer.

IMPORTANT-Terminal connections at the wall plate or subbase must be made securely. Loose control wire connections may allow unit to operate but not with proper response to room demand.

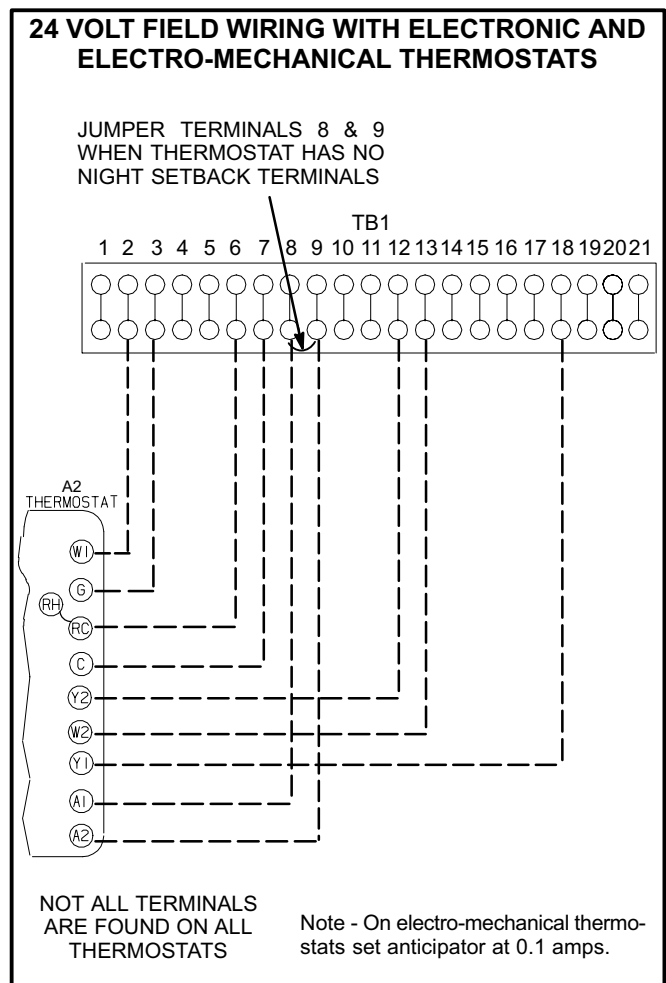

FIGURE 10

Blower Operation and Adjustments

▲ IMPORTANT

Three phase scroll compressors must be phased sequentially for correct compressor and blower rotation. Follow "COOLING START-UP" section of installation instructions to ensure proper compressor and blower operation.

A-Blower Operation

Initiate blower demand at thermostat according to instructions provided with thermostat. Unit will cycle on thermostat demand. The following steps apply to applications using a typical electro-mechanical thermostat.

- 1- Blower operation is manually set at the thermostat subbase fan switch. With fan switch in **ON** position, blowers will operate continuously.
- 2- With fan switch in **AUTO** position, the blowers will cycle with demand. Blowers and entire unit will be off when system switch is in **OFF** position.

B-Blower Access

- 1- Disconnect jack/plug connector to blower motor. Also disconnect jack/plug connector heating limit switches on units containing gas heat.
- 2- Remove screws on either side of blower assembly sliding base. See figure 11.
- 3- Pull base toward outside of unit.

C-Determining Unit CFM

- 1- The following measurements must be made with a dry indoor coil. Run blower without a cooling demand. Measure the indoor blower shaft RPM. Air filters must be in place when measurements are taken.
- 2- With all access panels in place, measure static pressure external to unit (from supply to return).
- 3- Referring to table 3, use static pressure and RPM readings to determine unit CFM. Use table 4 when installing units with any of the optional accessories listed.
- 4- The blower RPM can be adjusted at the motor pulley. Loosen Allen screw and turn adjustable pulley clockwise to increase CFM. Turn counterclockwise to decrease CFM. See figure 11. Do not exceed minimum and maximum number of pulley turns as shown in table 2.

TABLE 2
MINIMUM AND MAXIMUM PULLEY ADJUSTMENT

Belt	Minimum Turns Open	Maximum Turns Open
A Section	No minimum	5
B Section	1*	6

*No minimum number of turns open when B belt is used on pulleys 6" O.D. or larger.

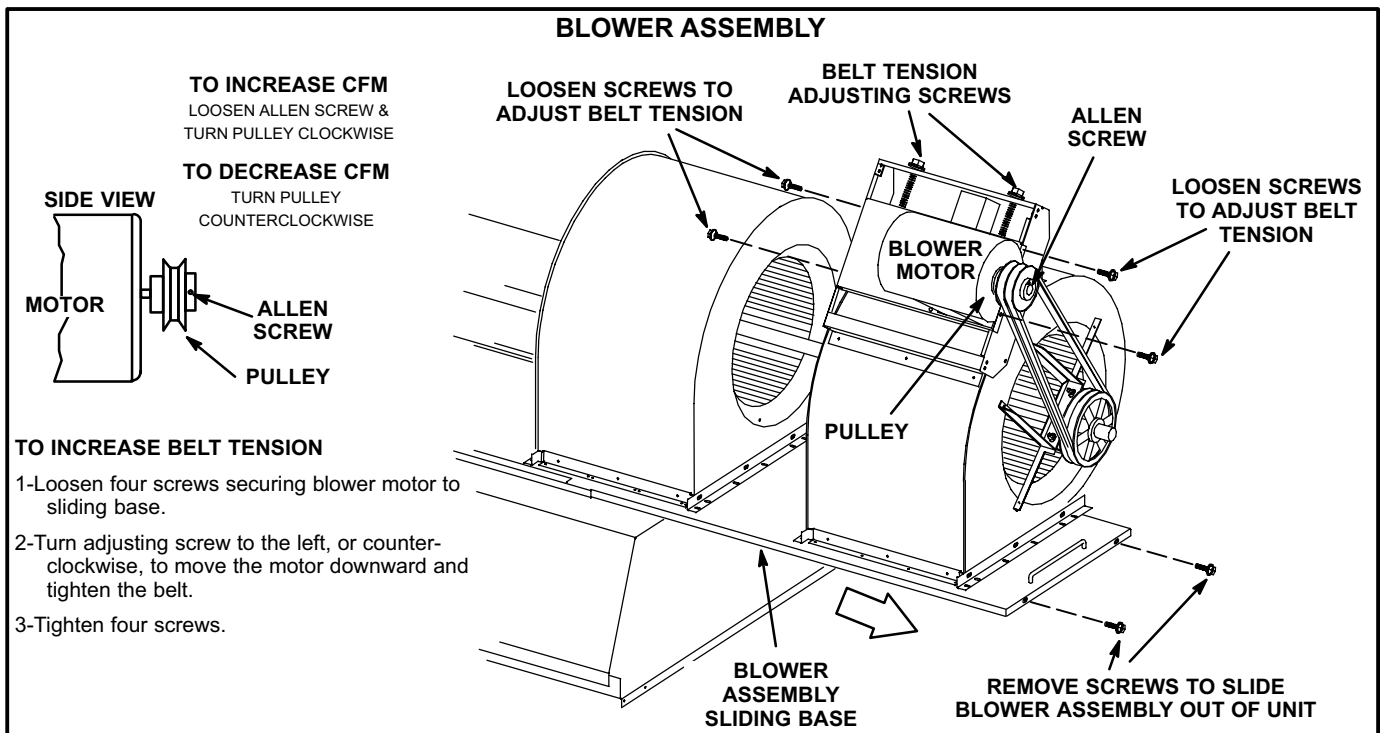

FIGURE 11

**TABLE 3
FACTORY INSTALLED OPTIONS/FIELD INSTALLED ACCESSORY AIR RESISTANCE**

BLOWER TABLE INCLUDES RESISTANCE FOR BASE UNIT ONLY WITH DRY INDOOR COIL & AIR FILTERS IN PLACE.
FOR ALL UNITS ADD:
 1 - Wet indoor coil air resistance of selected unit.
 2 - Any factory installed options air resistance (heat section, economizer, etc.)
 3 - Any field installed accessories air resistance (duct resistance, diffuser, etc.)
 Then determine from blower table blower motor output and drive required.
 See table 4 for wet coil and option/accessory air resistance data.
MINIMUM AIR VOLUME REQUIRED FOR USE WITH OPTIONAL ELECTRIC HEAT - 10,500 cfm (4955 L/s).
BOLD ITALIC INDICATES FIELD FURNISHED DRIVE

Air Volume cfm (L/s)	TOTAL STATIC PRESSURE — Inches Water Gauge (Pa)												
	.20 (50)	.40 (100)	.60 (150)	.80 (200)	1.00 (250)	1.20 (300)	1.40 (350)	1.60 (400)	1.80 (450)	2.00 (495)	2.20 (545)	2.40 (595)	2.60 (645)
	RPM BHP (kW)	RPMBHP (kW)	RPMBHP (kW)	RPMBHP (kW)	RPMBHP (kW)	RPMBHP (kW)	RPMBHP (kW)	RPMBHP (kW)	RPMBHP (kW)	RPMBHP (kW)	RPM BHP (kW)	RPM BHP (kW)	RPMBHP (kW)
6000 (2830)	---	435 1.20 <i>(0.90)</i>	525 1.45 <i>(1.08)</i>	570 1.60 (1.19)	630 2.00 (1.49)	700 2.35 (1.75)	750 2.80 (2.09)	795 3.15 (2.35)	840 3.40 (2.54)	880 3.80 (2.83)	920 4.20 (3.13)	960 4.65 (3.47)	995 5.10 (3.80)
6500 (3065)	---	445 1.30 <i>(0.97)</i>	530 1.60 <i>(1.19)</i>	580 1.80 (1.34)	640 2.20 (1.64)	705 2.60 (1.94)	755 3.05 (2.28)	800 3.40 (2.54)	845 3.70 (2.76)	885 4.15 (3.10)	925 4.60 (4.43)	965 5.00 (3.73)	1000 5.45 (4.07)
7000 (3305)	---	455 1.40 <i>(1.04)</i>	535 1.75 <i>(1.31)</i>	590 2.05 (1.53)	650 2.45 (1.83)	710 2.85 (2.13)	760 3.30 (2.46)	805 3.70 (2.76)	850 4.05 (3.02)	890 4.50 (3.36)	930 4.95 (3.69)	970 5.40 (4.03)	1005 5.85 (4.36)
7500 (3540)	380 1.05 <i>(0.78)</i>	465 1.50 <i>(1.12)</i>	540 1.90 <i>(1.42)</i>	600 2.30 (1.72)	660 2.70 (2.01)	715 3.15 (2.35)	765 3.60 (2.69)	810 4.00 (2.98)	855 4.45 (3.32)	895 4.90 (3.66)	935 5.35 (3.99)	975 5.85 (4.36)	1010 6.30 (4.70)
8000 (3775)	390 1.25 <i>(0.93)</i>	475 1.65 <i>(1.23)</i>	545 2.10 <i>(1.57)</i>	610 2.55 (1.90)	665 2.95 (2.20)	720 3.45 (2.57)	770 3.90 (2.91)	815 4.35 (3.25)	860 4.85 (3.62)	900 5.30 (3.95)	940 5.75 (4.29)	980 6.30 (4.70)	1015 6.75 (5.04)
8500 (4010)	405 1.40 <i>(1.04)</i>	485 1.90 <i>(1.42)</i>	555 2.35 <i>(1.75)</i>	620 2.80 (2.09)	675 3.30 (2.46)	725 3.75 (2.80)	775 4.20 (3.13)	820 4.70 (3.51)	865 5.20 (3.88)	905 5.70 (4.25)	945 6.20 (4.63)	985 6.75 (5.04)	1020 7.25 (5.41)
9000 (4245)	415 1.60 <i>(1.19)</i>	495 2.10 <i>(1.57)</i>	565 2.60 <i>(1.94)</i>	625 3.10 (2.31)	685 3.60 (2.69)	735 4.10 (3.06)	785 4.60 (3.43)	830 5.10 (3.80)	870 5.60 (4.18)	915 6.15 (4.59)	955 6.70 (5.00)	990 7.20 (5.37)	1025 7.70 (5.74)
9500 (4485)	430 1.85 <i>(1.38)</i>	505 2.35 <i>(1.75)</i>	575 2.90 <i>(2.16)</i>	635 3.40 (2.54)	690 3.90 (2.91)	745 4.50 (3.36)	790 4.95 (3.69)	835 5.50 (4.10)	880 6.05 (4.51)	920 6.60 (4.92)	960 7.15 (5.33)	995 7.70 (5.74)	1035 8.30 (6.19)
10,000 (4720)	445 2.10 <i>(1.57)</i>	520 2.65 <i>(1.98)</i>	585 3.20 <i>(2.39)</i>	645 3.75 (2.80)	700 4.30 (3.21)	750 4.85 (3.64)	800 5.40 (4.03)	845 5.95 (4.44)	885 6.50 (4.85)	925 7.05 (5.26)	965 7.65 (5.71)	1000 8.20 (6.12)	1040 8.85 (6.60)
10,500 (4955)	455 2.35 <i>(1.75)</i>	530 2.95 <i>(2.20)</i>	595 3.50 <i>(2.61)</i>	655 4.10 (3.06)	710 4.70 (3.03)	760 5.25 (3.92)	805 5.80 (4.33)	850 6.40 (4.77)	895 7.00 (5.22)	935 7.60 (5.67)	970 8.15 (6.08)	1010 8.80 (6.56)	1045 9.40 (7.01)
11,000 (5190)	470 2.60 <i>(1.94)</i>	545 3.25 <i>(2.42)</i>	605 3.85 <i>(2.87)</i>	665 4.45 (3.32)	720 5.10 (3.80)	765 5.66 (4.22)	815 6.30 (4.70)	860 6.90 (5.15)	900 7.50 (5.60)	940 8.10 (6.04)	980 8.75 (6.53)	1015 9.35 (6.98)	-----
11,500 (5425)	485 2.95 <i>(2.20)</i>	555 3.60 <i>(2.69)</i>	620 4.25 <i>(3.17)</i>	675 4.85 (3.62)	730 5.55 (4.14)	775 6.10 (4.55)	820 6.70 (5.00)	865 7.40 (5.52)	910 8.05 (6.01)	945 8.65 (6.45)	985 9.30 (6.94)	1020 9.95 (7.42)	-----
12,000 (5665)	500 3.30 <i>(2.46)</i>	570 4.00 (2.98)	630 4.65 <i>(3.47)</i>	685 5.30 (3.95)	740 6.00 (4.48)	785 6.60 (4.92)	830 7.25 (5.41)	875 7.95 (5.93)	915 8.60 (6.42)	955 9.25 (6.90)	995 9.95 (7.42)	1030 10.60 (7.91)	-----
12,500 (5900)	515 3.65 <i>(2.72)</i>	580 4.35 (3.25)	640 5.05 <i>(3.77)</i>	695 5.75 (4.29)	750 6.50 (4.85)	795 7.10 (5.30)	840 7.80 (5.82)	885 8.55 (6.38)	925 9.20 (6.86)	965 9.90 (7.39)	1000 10.55 (7.87)	1035 11.25 (8.39)	-----
13,000 (6135)	530 4.05 <i>(3.02)</i>	595 4.80 (3.58)	655 5.55 <i>(4.14)</i>	710 6.25 (4.66)	760 7.00 (5.22)	805 7.65 (5.71)	850 8.40 (6.27)	890 9.05 (6.75)	930 9.75 (7.27)	970 10.50 (7.83)	1010 11.30 (8.43)	-----	-----
13,500 (6370)	545 4.45 <i>(3.32)</i>	610 5.25 (3.92)	665 6.00 <i>(4.48)</i>	720 6.75 (5.04)	770 7.50 (5.60)	815 8.25 (6.15)	860 9.00 (6.71)	900 9.70 (7.24)	940 10.45 (7.80)	980 11.20 (8.36)	-----	-----	-----
14,000 (6605)	560 4.90 (3.66)	620 5.70 (4.25)	680 6.55 (4.89)	730 7.30 (5.45)	780 8.10 (6.04)	825 8.85 (6.60)	870 9.65 (7.20)	910 10.40 (7.76)	950 11.15 (8.31)	-----	-----	-----	-----
14,500 (6845)	575 5.40 (4.03)	635 6.25 (4.66)	690 7.05 (5.26)	745 7.90 (5.89)	790 8.65 (6.45)	835 9.45 (7.05)	880 10.30 (7.68)	920 11.10 (8.28)	-----	-----	-----	-----	-----
15,000 (7080)	590 5.90 (4.40)	650 6.80 (5.07)	705 7.65 (5.71)	755 8.50 (6.34)	800 9.30 (6.94)	845 10.10 (7.53)	890 11.00 (8.21)	-----	-----	-----	-----	-----	-----

**TABLE 4
FACTORY INSTALLED OPTIONS/FIELD INSTALLED ACCESSORY AIR RESISTANCE**

Air Volume		Total Resistance — inches water gauge (Pa)						
		Wet Indoor Coil	Gas Heat Exchanger (LGA/LGC Models)		Electric Heat (LCA/LCC Models)	Economizer	Horizontal Roof Mounting Frame	MERV 11 Filter
			Low Fire	High Fire				
cfm	L/s							
6000	2830	.04 (10)	.12 (30)	.19 (47)	.02 (5)	.01 (3)	.08 (20)	.01 (2)
6500	3070	.05 (13)	.13 (32)	.21 (52)	.02 (5)	.01 (3)	.09 (22)	.01 (2)
7000	3305	.06 (15)	.14 (35)	.24 (59)	.03 (7)	.02 (5)	.10 (25)	.01 (2)
7500	3540	.07 (17)	.15 (37)	.25 (62)	.03 (7)	.02 (5)	.11 (27)	.02 (5)
8000	3775	.08 (20)	.17 (42)	.28 (70)	.03 (7)	.02 (5)	.13 (32)	.02 (5)
8500	4010	.08 (20)	.20 (50)	.31 (77)	.04 (10)	.03 (7)	.15 (37)	.02 (5)
9000	4245	.09 (22)	.22 (55)	.34 (85)	.04 (10)	.04 (10)	.17 (42)	.02 (5)
9500	4485	.10 (25)	.24 (60)	.38 (94)	.05 (12)	.04 (10)	.19 (47)	.03 (7)
10,000	4720	.11 (27)	.27 (67)	.42 (104)	.05 (12)	.05 (12)	.21 (52)	.03 (7)
10,500	4955	.12 (30)	.30 (75)	.46 (114)	.06 (15)	.06 (15)	.24 (60)	.03 (7)
11,000	5190	.12 (30)	.33 (92)	.50 (137)	.06 (15)	.07 (17)	.27 (67)	.04 (10)
11,500	5425	.13 (32)	.37 (92)	.55 (137)	.07 (17)	.08 (20)	.30 (75)	.04 (10)
12,000	5665	.14 (35)	.40 (99)	.60 (149)	.07 (17)	.10 (25)	.33 (82)	.04 (10)
12,500	5900	.15 (37)	.44 (109)	.65 (162)	.08 (20)	.11 (27)	.37 (92)	.05 (12)
13,000	6135	.16 (40)	.48 (119)	.70 (174)	.08 (20)	.13 (32)	.40 (99)	.05 (12)
13,500	6370	.17 (42)	.53 (132)	.76 (189)	.09 (22)	.14 (35)	.44 (109)	.06 (15)
14,000	6605	.18 (45)	.57 (142)	.82 (204)	.10 (25)	.16 (40)	.49 (122)	.06 (15)
14,500	6845	.19 (47)	.62 (154)	.89 (221)	.10 (25)	.18 (45)	.53 (132)	.06 (15)
15,000	7080	.20 (50)	.68 (169)	.95 (236)	.11 (27)	.21 (52)	.58 (144)	.07 (17)

D-Blower Belt Adjustment

Maximum life and wear can be obtained from belts only if proper pulley alignment and belt tension are maintained. Tension new belts after a 24-48 hour period of operation. This will allow belt to stretch and seat grooves. Make sure blower and motor pulley are aligned as shown in figure 12.

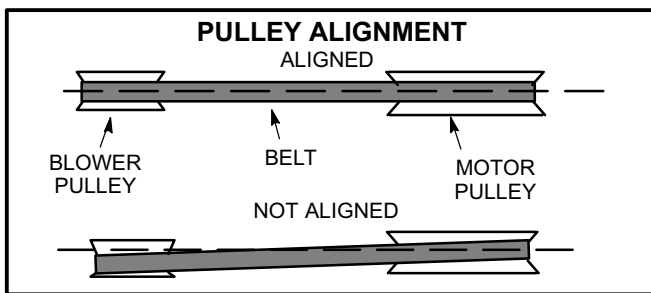

FIGURE 12

- 1- Loosen four screws securing blower motor to sliding base. See figure 11.
- 2- *To increase belt tension* - Turn belt tension adjusting screw to the left, or counterclockwise, to tighten the belt. This increases the distance between the blower motor and the blower housing.

To loosen belt tension -

Turn the adjusting screw to the right, or clockwise to loosen belt tension.

To loosen belt tension -

Turn the adjusting screw to the right, or clockwise to loosen belt tension.

- 3- Tighten four screws securing blower motor to sliding base once adjustments have been made.

E-Check Belt Tension

Overtensioning belts shortens belt and bearing life. Check belt tension as follows:

- 1- Measure span length X. See figure 13.

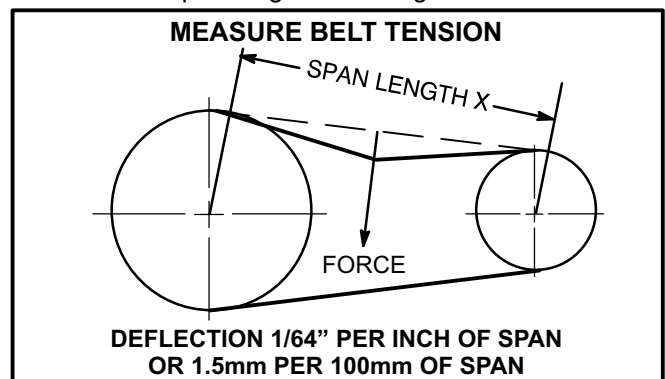

FIGURE 13

- 2- Apply perpendicular force to center of span (X) with enough pressure to deflect belt 1/64" for every inch of span length or 1.5mm per 100mm of span length.

Example: Deflection distance of a 40" span would be 40/64" or 5/8".

Example: Deflection distance of a 400mm span would be 6mm.

- 3- Measure belt deflection force. For a used belt, the deflection force should be 5 lbs. (35kPa). A new belt deflection force should be 7 lbs. (48kPa).

A force below these values indicates an undertensioned belt. A force above these values indicates an overtensioned belt.

F-Field-Furnished Blower Drives

For field-furnished blower drives, use tables 3 and 4 to determine BHP and RPM required. Reference table 5 to determine the drive number and table 6 or 7 to determine the manufacturer's model number.

Cooling Start-Up

IMPORTANT-The crankcase heater must be energized for 24 hours before attempting to start compressor. Set thermostat so there is no demand to prevent compressors from cycling.

⚠ IMPORTANT

Units contain either R22 or R410A refrigerant. Check the nameplate to determine the type of refrigerant before installation or servicing.

NOTE - These units must not be used as a "construction heater" at any time during any phase of construction. Very low return air temperatures, harmful vapors, and misplacement of the filters will damage the unit and its efficiency. Additionally, a unit which will be subject to cold temperatures when not in operation must have a vapor barrier installed to seal the duct connections. Failure to protect the unit from moisture laden air or harmful vapors (generated from the construction process and temporary combustion heating equipment) will cause corrosive condensation within the unit. Failure to properly protect the unit in this situation will cause electrical and electronic component failure and could affect the unit warranty status.

**TABLE 5
FACTORY INSTALLED DRIVE KIT SPECIFICATIONS**

Motor		RPM Range											
hp	kw	Drive 1		Drive 2		Drive 3		Drive 4		Drive 5		Drive 6	
		60 Hz	50 Hz	60 Hz	50 Hz	60 Hz	50 Hz	60 Hz	50 Hz	60 Hz	50 Hz	60 Hz	50 Hz
5	3.7	660/810	630/790	770/965	710/900	---	---	---	---	---	---	560/710	---
7.5	5.6	---	---	---	---	715/880	710/870	770/965	700/840	850/1045	830/980	---	---
10	7.5	---	---	---	---	715/880	710/870	770/965	700/840	850/1045	870/1020	---	---

In Canada, nominal motor output is also maximum usable motor output. If motors of comparable output are used, be sure to keep within the service factor limitations outlined on the motor nameplate.

**TABLE 6
MANUFACTURER'S NUMBERS (60 HZ)**

DRIVE NO.	DRIVE COMPONENTS					
	ADJUSTABLE SHEAVE		FIXED SHEAVE		BELTS (2 REQUIRED)	
	BROWNING NO.	OEM PART NO.	BROWNING NO.	OEM PART NO.	BROWNING NO.	OEM PART NO.
1	2VP56x1-1/8	P-8-3026	2BK120Hx1-7/16	49K3301	BX71	31K9701
2	2VP60x1-1/8	P-8-9161	2BK110Hx1-7/16	P-8-2725	BX71	31K9701
3	2VP65x1-3/8	97J5601	2BK130Hx1-7/16	P-8-2724	BX75	31K9801
4	2VP60x1-3/8	97J5701	2BK110Hx1-7/16	P-8-2725	BX71	31K9701
5	2VP65x1-3/8	97J5601	2BK110Hx1-7/16	P-8-2725	BX71	31K9701
6	2VP50x1-1/8	97J5401	2BK120Hx1-7/16	49K3301	BX70	31K9601

**TABLE 7
MANUFACTURER'S NUMBERS (50 HZ)**

DRIVE NO.	DRIVE COMPONENTS							
	ADJUSTABLE SHEAVE		FIXED SHEAVE		BELTS (2 REQUIRED)		SPLIT BUSHING	
	BROWNING NO.	OEM PART NO.	BROWNING NO.	OEM PART NO.	BROWNING NO.	OEM PART NO.	BROWNING NO.	OEM PART NO.
1	2VP50x1-1/8	97J5401	2BK90Hx1-7/16	49K3201	BX64	97J5801	H -1 7/16	53A1201
2	2VP50x1-1/8	97J5401	2BK80Hx1-7/16	58K2101	BX63	97J5501	H -1 7/16	53A1201
3	2VP65x1-3/8	97J5601	2BK110Hx1-7/16	P-8-2725	BX71	31K9701	H -1 7/16	53A1201
4	2VP62x1-3/8	73K3901	2BK110Hx1-7/16	P-8-2725	BX63	31K9701	H -1 7/16	53A1201
5	2VP68x1-3/8	P-8-6314	2BK100Hx1-7/16	P-8-4668	BX63	31K9701	H -1 7/16	53A1201

A-Preliminary Checks

- 1- Make sure that unit is installed in accordance with the installation instructions and applicable codes.
- 2- Inspect all electrical wiring, both field- and factory-installed, for loose connections. Tighten as required.
- 3- Check to ensure that refrigerant lines do not rub against the cabinet or against other refrigerant lines.
- 4- Check voltage at disconnect switch. Voltage must be within range listed on nameplate. If not, consult power company and have voltage condition corrected before starting unit.
- 5- Make sure filters are in place before start-up.

B-Start-Up

- 1- Initiate first and second stage cooling demands according to instructions provided with thermostat.
- 2- First-stage thermostat demand will energize compressors 1 and 2. Second-stage thermostat demand will energize compressors 3 and 4 (fourth compressor on 21 and 25 ton units). On units with an economizer, when outdoor air is acceptable, a first-stage demand will energize the economizer; a second-stage demand will energize compressors 1 and 2.
- 3- *248 & 300H* -
Units contain four refrigerant circuits or systems. Evaporator and condenser coil refrigerant circuits 1 and 2 make up stage 1 cooling. Evaporator and condenser refrigerant circuits 3 and 4 make up stage 2 cooling. See figure 14.

360H -

Units contain three refrigerant circuits or systems. Evaporator and condenser coil refrigerant circuits 1 and 2 make up stage 1 cooling. Evaporator and condenser coil refrigerant circuit 3 makes up stage 2 cooling. See figure 15.

- 4- Each refrigerant circuit is separately charged with HCFC-22 or R410A refrigerant. See unit rating plate for correct amount of charge.
- 5- Refer to Cooling Operation and Adjustment section for proper method to check refrigerant charge.

C-Three Phase Scroll Compressor Voltage Phasing

Three phase scroll compressors must be phased sequentially to ensure correct compressor and blower rotation and operation. Compressor and blower are wired in phase at the factory. Power wires are color-coded as follows: line 1-red, line 2-yellow, line 3-blue.

- 1- Observe suction and discharge pressures and blower rotation on unit start-up.
- 2- Suction pressure must drop, discharge pressure must rise, and blower rotation must match rotation marking.

If pressure differential is not observed or blower rotation is not correct:

- 3- Disconnect all remote electrical power supplies.
- 4- Reverse any two field-installed wires connected to the line side of S48 disconnect or TB13 terminal strip.
Do not reverse wires at blower contactor.
- 5- Make sure the connections are tight.

Discharge and suction pressures should operate at their normal start-up ranges.

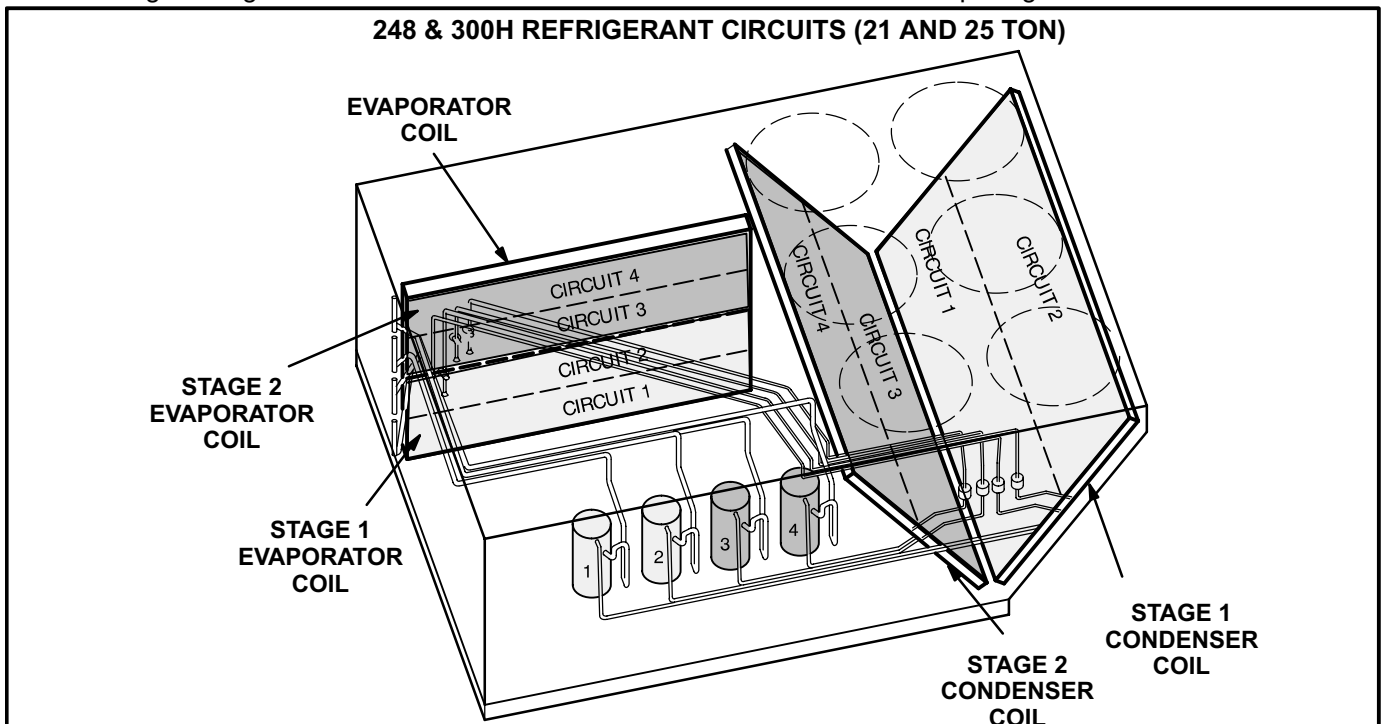

FIGURE 14

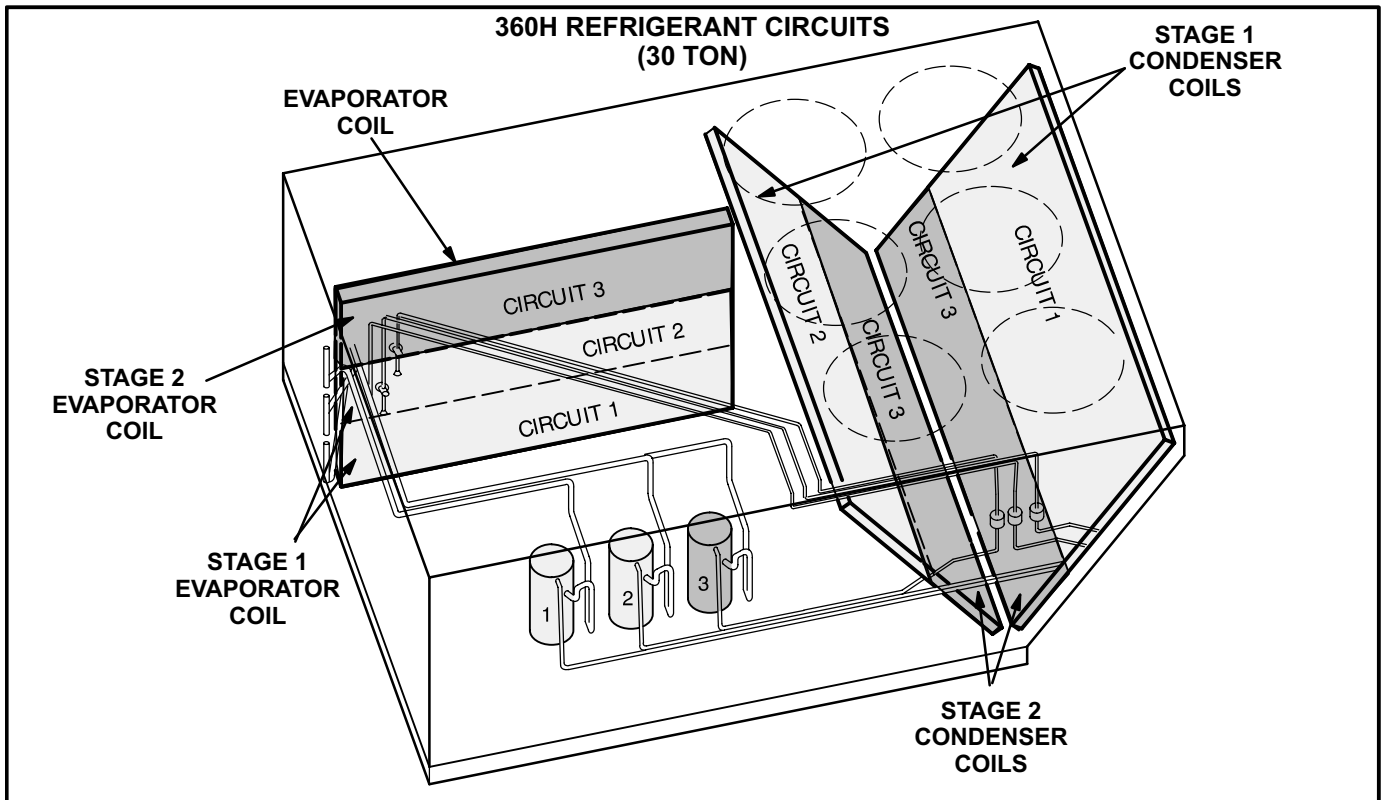

FIGURE 15

Cooling Start-Up - Continued

D-R410A Refrigerant

Units charged with R410A refrigerant operate at much higher pressures than R22. The expansion valve and liquid line drier provided with the unit are approved for use with R410A. Do not replace them with components designed for use with R22.

R410A refrigerant is stored in a pink cylinder.

▲ IMPORTANT

Mineral oils are not compatible with R410A. If oil must be added, it must be a polyol ester oil.

Manifold gauge sets used with systems charged with R410A refrigerant must be capable of handling the higher system operating pressures. The gauges should be rated for use with pressures of 0-800 on the high side and a low side of 30" vacuum to 250 psi with dampened speed to 500 psi. Gauge hoses must be rated for use at up to 800 psi of pressure with a 4000 psi burst rating.

E-Refrigerant Charge and Check

WARNING-Do not exceed nameplate charge under any condition.

This unit is factory charged and should require no further adjustment. If the system requires charge, *reclaim the charge, evacuate the system, and add required nameplate charge.*

*NOTE - System charging is not recommended below 60° F (15° C). In temperatures below 60° F (15° C) , the charge **must** be weighed into the system.*

If weighing facilities are not available, or to check the charge, use the following procedure:

IMPORTANT - Charge unit in standard cooling mode.

- 1- Attach gauge manifolds and operate unit in cooling mode until system stabilizes (approximately five minutes). Make sure all outdoor air dampers are closed.
- 2- Check each system separately with all stages operating.
- 3- Use a thermometer to accurately measure the outdoor ambient temperature.
- 4- Apply the outdoor temperature to tables 8 through 12 to determine normal operating pressures.
- 5- Compare the normal operating pressures to the pressures obtained from the gauges. Minor variations in these pressures may be expected due to differences in installations. Significant differences could mean that the system is not properly charged or that a problem exists with some component in the system. **Correct any system problems before proceeding.**

6- If discharge pressure is high, remove refrigerant from the system. If discharge pressure is low, add refrigerant to the system.

- Add or remove charge in increments.
- Allow the system to stabilize each time refrigerant is added or removed.

7- Use the following approach method along with the normal operating pressures to confirm readings.

TABLE 8
LGA/LCA248H - R22

Outdoor Coil Entering Air Temp	CIRCUIT 1		CIRCUIT 2		CIRCUIT 3		CIRCUIT 4	
	Dis +10 psig	Suc +5 psig	Dis +10 psig	Suc +5 psig	Dis +10 psig	Suc +5 psig	Dis +10 psig	Suc +5 psig
65°F*	158	68	156	72	157	75	156	72
75°F	181	69	183	77	190	82	190	80
85°F	207	70	211	77	218	83	217	80
95°F	235	71	241	78	248	84	248	82
105°F	269	74	273	80	282	86	284	86
115°F	304	76	310	82	320	87	322	85

*Outdoor fans may cycle on and off at this temperature.

TABLE 9
LGA/LCA248H - R410A

Outdoor Coil Entering Air Temp	CIRCUIT 1		CIRCUIT 2		CIRCUIT 3		CIRCUIT 4	
	Dis. +10 psig	Suc. +5 psig	Dis. +10 psig	Suc. +5 psig	Dis. +10 psig	Suc. +5 psig	Dis. +10 psig	Suc. +5 psig
65°F*	248	120	250	134	250	139	251	136
75°F	284	122	287	137	288	143	290	139
85°F	324	125	329	139	329	145	332	142
95°F	367	127	374	141	375	147	379	145
105°F	415	131	425	144	425	150	430	147
115°F	468	139	478	146	475	152	485	150

*Outdoor fans may cycle on and off at this temperature.

TABLE 10
LGC/LCC300H - R22

Outdoor Coil Entering Air Temp	CIRCUIT 1		CIRCUIT 2		CIRCUIT 3		CIRCUIT 4	
	Dis +10 psig	Suc +5 psig	Dis +10 psig	Suc +5 psig	Dis +10 psig	Suc +5 psig	Dis +10 psig	Suc +5 psig
65°F*	159	69	162	72	154	73	150	69
75°F	182	70	189	74	187	77	186	72
85°F	217	72	222	76	222	79	216	74
95°F	252	73	255	77	255	80	252	75
105°F	287	75	289	79	290	82	289	77
115°F	322	77	322	81	325	84	324	79

*Outdoor fans may cycle on and off at this temperature.

TABLE 11
LGA/LCA360H - R22

Outdoor Coil Entering Air Temp	CIRCUIT 1		CIRCUIT 2		CIRCUIT 3	
	Dis +10 psig	Suc +5 psig	Dis +10 psig	Suc +5 psig	Dis +10 psig	Suc +5 psig
65°F*	164	63	176	76	178	75
75°F	191	64	207	77	206	76
85°F	219	66	233	78	234	77
95°F	250	68	270	80	271	78
105°F	284	70	303	81	301	79
115°F	320	72	346	82	345	81

*Outdoor fans may cycle on and off at this temperature.

TABLE 12
LGA/LCA360H R410A

Outdoor Coil Entering Air Temp	CIRCUIT 1		CIRCUIT 2		CIRCUIT 3	
	Dis +10 psig	Suc +5 psig	Dis +10 psig	Suc +5 psig	Dis +10 psig	Suc +5 psig
65°F*	286	111	307	125	302	123
75°F	320	115	351	130	336	129
85°F	363	119	397	132	382	133
95°F	413	122	448	135	430	137
105°F	465	126	501	137	478	140
115°F	523	130	561	142	534	141

*Outdoor fans may cycle on and off at this temperature.

F-Charge Verification - Approach Method

1- Using the same thermometer, compare liquid temperature to outdoor ambient temperature.

Approach Temperature = Liquid temperature minus ambient temperature.

2- Approach temperature should match values in table 13. An approach temperature greater than value shown indicates an undercharge. An approach temperature less than value shown indicates an overcharge.

3- Do not use the approach method if system pressures do not match pressures in tables 8 through 12. The approach method is not valid for grossly over or undercharged systems.

TABLE 13

Unit	Liquid Temp. Minus Ambient Temp.			
	1st Stage	2nd Stage	3rd Stage	4th Stage
248 R22	6°F ± 1 (3.3°C ± 0.5)	6°F ± 1 (3.3°C ± 0.5)	6°F ± 1 (3.3 ± 0.5)	6°F ± 1 (3.3 ± 0.5)
248 R410A	6°F ± 1 (3.3°C ± 0.5)	6°F ± 1 (3.3°C ± 0.5)	6°F ± 1 (3.3°C ± 0.5)	6°F ± 1 (3.3 ± 0.5)
300H R22	6°F ± 1 (3.3°C ± 0.5)	7°F ± 1 (3.9°C ± 0.5)	5°F ± 1 (2.8 ± 0.5)	5°F ± 1 (2.8 ± 0.5)
360H R22	8°F ± 1 (4.4°C ± 0.5)	10°F ± 1 (5.6°C ± 0.5)	8°F ± 1 (4.4°C ± 0.5)	NA
360H R410A	12°F ± 1 (6.7°C ± 0.5)	14°F ± 1 (7.8°C ± 0.5)	13°F ± 1 (7.2°C ± 0.5)	NA

G-Compressor Controls

See unit wiring diagram to determine which controls are used on each unit.

- 1- High Pressure Switch (S4, S7, S28, S96) **R22**
The compressor circuit is protected by a high pressure switch which cuts out at 450 psig \pm 10 psig (3103 kPa \pm 70 kPa) and automatically resets at 300 psig \pm 20psig (2069kPa \pm 138kPa).

High Pressure Switch (S4, S7, S28, S96) **R410A**
The compressor circuit is protected by a high pressure switch which opens at 640 psig \pm 10 psig (4413 kPa \pm 70 kPa) and automatically resets at 475 psig \pm 20 psig (3275kPa \pm 138 kPa).

- 2- Low Pressure Switch (S87, S88, S97, S98) **R22**
The compressor circuit is protected by a low pressure switch. Switch cuts out at 25 psig (172 kPa) and automatically resets at 55 psig (379 kPa).

Low Pressure Switch (S87, S88, S97, S98) **R410A**
The compressor circuit is protected by a loss of charge switch. Switch opens at 40 psig \pm 5 psig (276 \pm 34 kPa) and automatically resets at 90 psig \pm 5 psig (621 kPa \pm 34 kPa).

- 3- Crankcase Heater (HR1, HR2, HR5, HR11)
Units have compressors which contain a belly band compressor oil heater which must be on 24 hours before running compressors. Energize by setting thermostat so that there is no cooling demand, to prevent compressor from cycling, and apply power to unit.

- 4- Freezestats (S49, S50, S53, S95)
Switches de-energize compressors when evaporator coil temperature falls below 29°F (-2°C) to prevent evaporator freeze-up. Switches reset when evaporator coil temperature reaches 58°F (15°C).

- 5- Low Ambient Pr. Sw. (S11, S84, S85, S94) **R22**
Switch maintains adequate discharge pressure by de-energizing condenser fan when liquid pressure falls below 150 psig (1034kPa). Switch closes to energize condenser fans when pressure rises to 275 psig (1896kPa).

Low Ambient Pr. Sw. (S11, S84, S85, S94) **R410A**
Switch maintains adequate discharge pressure by de-energizing condenser fan when liquid pressure falls below 240 psig \pm 10 (1655 kPa \pm 69). Switch closes to energize condenser fan when pressure rises to 450 psig \pm 10 (3103kPa \pm 69).

248 & 300H

Condenser fans 1, 2, and 3 are energized on a Y1 cooling demand; condenser fans 4, 5, and 6 are energized on a Y2 cooling demand. Condenser fans 1, 2, 5, and 6 are energized after a 75 second delay. See figure 16.

Condenser fans 2 and 5 are de-energized when outdoor temperature drops below 55°F (13°C). Condenser fans 1 and 6 are de-energized when outdoor air temperature is below 40°F (4°C).

Condenser fan 3 is cycled by S11 and S84 pressure switches (via K10) located in refrigerant circuits 1 and 2 respectively.

Condenser fan 4 is cycled by S85 and S94 pressure switches (via K149) located in refrigerant circuits 3 and 4.

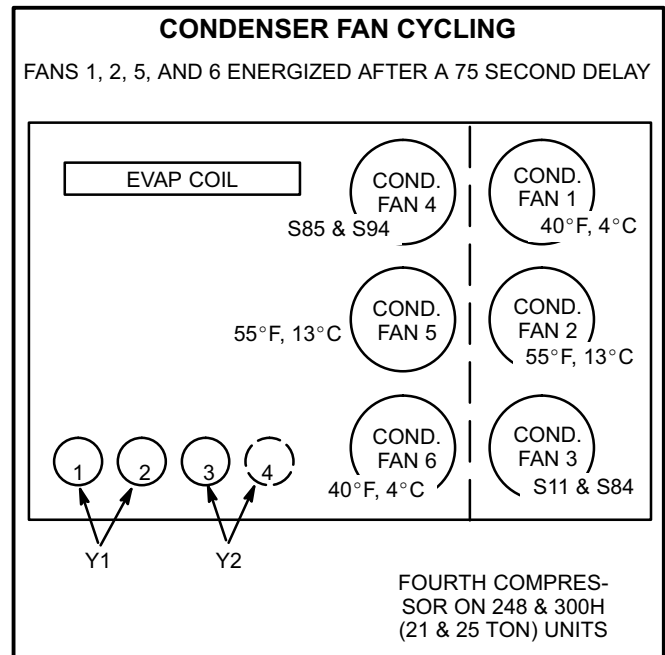

FIGURE 16

360H

All six condenser fans are energized on a Y1 cooling demand and continue to operate when Y2 demand is initiated. Condenser fans 1, 2, 5, and 6 are energized after a 75 second delay.

Condenser fans 2 and 5 are de-energized when outdoor temperature drops below 55°F (13°C). Condenser fans 1 and 6 are de-energized when outdoor air temperature is below 40°F (4°C).

S11, S84, and S85 pressure switches (in refrigerant circuits 1, 2, and 3 respectively) are in parallel; any ONE switch will cycle both condenser fans 3 and 4.

Gas Heat Start-Up (Gas Units)

FOR YOUR SAFETY READ BEFORE LIGHTING

BEFORE LIGHTING smell all around the appliance area for gas. Be sure to smell next to the floor because some gas is heavier than air and will settle on the floor.

Use only your hand to push in or turn the gas control knob. Never use tools. If the knob will not push in or turn by hand, do not try to repair it, call a qualified service technician. Force or attempted repair may result in a fire or explosion.

⚠️ WARNING



Electric shock hazard. Can cause injury or death. Do not use this unit if any part has been under water. Immediately call a qualified service technician to inspect the unit and to replace any part of the control system and any gas control which has been under water.

⚠️ WARNING



Electric shock hazard. Can cause injury or death. Before attempting to perform any service or maintenance, turn the electrical power to unit OFF at disconnect switch(es). Unit may have multiple power supplies.

⚠️ WARNING



Danger of explosion. Can cause injury or product or property damage. If overheating occurs or if gas supply fails to shut off, shut off the manual gas valve to the appliance before shutting off electrical supply.

⚠️ WARNING

SMOKE POTENTIAL

The heat exchanger in this unit could be a source of smoke on initial firing. Take precautions with respect to building occupants and property. Vent initial supply air outside when possible.

⚠️ WARNING



Danger of explosion. Can cause injury or death. Do not attempt to light manually. Unit has a direct spark ignition system.

This unit is equipped with an automatic spark ignition system. There is no pilot. In case of a safety shutdown, move thermostat switch to **OFF** and return the thermostat switch to **HEAT** to reset ignition control.

A-Placing Unit In Operation

⚠️ WARNING



Danger of explosion and fire. Can cause injury or product or property damage. You must follow these instructions exactly.

Gas Valve Operation for White Rodgers 36C Series Valve (Figure 17) and Honeywell VR8305Q (Figure 18) Series Gas Valve

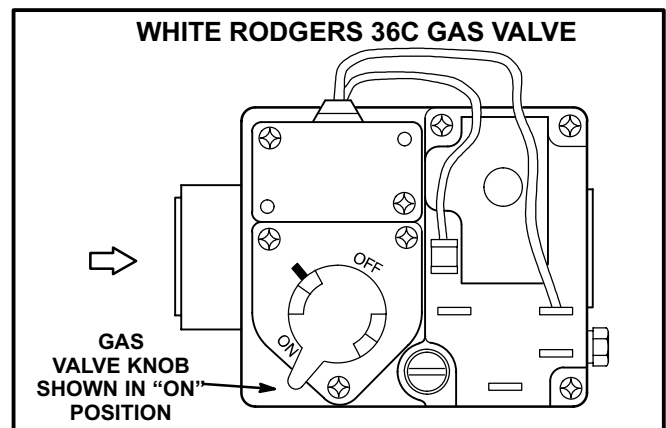

FIGURE 17

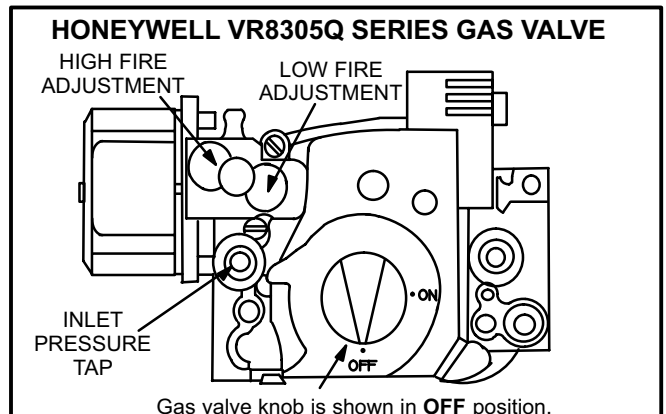





FIGURE 18

- 1- Set thermostat to lowest setting.
- 2- Turn off all electrical power to appliance.
- 3- This appliance is equipped with an ignition device which automatically lights the burner. Do **not** try to light the burner by hand.
- 4- Open or remove the heat section access panel.
- 5- Turn the knob on the gas valve clockwise  to **OFF**. Do not force.

- 6- Wait five minutes to clear out any gas. If you then smell gas, **STOP!** Immediately call your gas supplier from a neighbor's phone. Follow the gas supplier's instructions. If you do not smell gas, go to the next step.
- 7- Turn the knob on the gas valve counterclockwise  to **ON**. Do not force.
- 8- Close or replace the heat section access panel.
- 9- Turn on all electrical power to unit.
- 10- Set thermostat to desired setting.
- 11- The combustion air inducer will start. The burners will light within 40 seconds.
- 12- If the appliance does not light the first time (gas line not fully purged), it will attempt up to two more ignitions before locking out.
- 13- If lockout occurs, repeat steps 1 through 10.
- 14- If the appliance will not operate, follow the instructions "Turning Off Gas to Appliance" and call your service technician or gas supplier.

Turning Off Gas to Unit

- 1- If using an electromechanical thermostat, set to the lowest setting.
- 2- Before performing any service, turn off all electrical power to the unit.
- 3- Open or remove the heat section access panel.
- 4- Turn the knob on the gas valve clockwise  to **OFF**. Do not force.
- 5- Close or replace the heat section access panel.

Heating Operation and Adjustments

(Gas Units)

A-Heating Sequence of Operation

- 1- On a heating demand the combustion air inducer starts immediately.
- 2- Combustion air pressure switch proves inducer operation, then allows power to ignition control. Switch is factory set and requires no adjustment.
- 3- After a 45-second prepurge, spark ignitor energizes and gas valve solenoid opens.
- 4- Spark ignites gas, ignition sensor proves the flame and combustion continues.
- 5- If flame is not detected after first ignition trial, ignition control will repeat steps 3 and 4 two more times before locking out the gas valve.

- 6- For troubleshooting purposes, an ignition attempt after lock out may be re-established manually. Move thermostat to "OFF" and return thermostat switch to "HEAT" position.

B-Limit Controls

Limit controls are factory-set and are not adjustable. One of the primary limits is located in the bottom right corner of blower section. The other primary limit is accessed from the condenser coil side of the heat section. The secondary limits are located on the back side of the blower housing.

C-Heating Adjustment

Main burners are factory-set and do not require adjustment.

Check the spark gap on the ignitor and the position of the flame sensor as follows:

- 1- Loosen four screws and remove burner support cap. See figure 19.

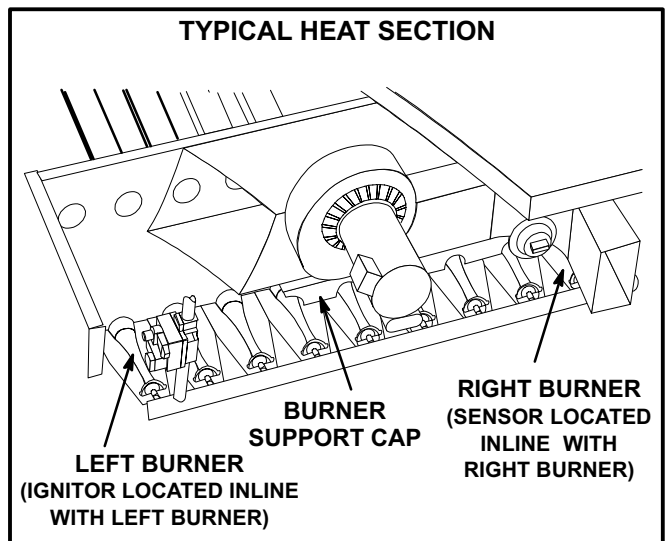

FIGURE 19

- 2- Remove left burner and check spark gap with appropriately sized twist drills or feeler gauges. See figure 20.

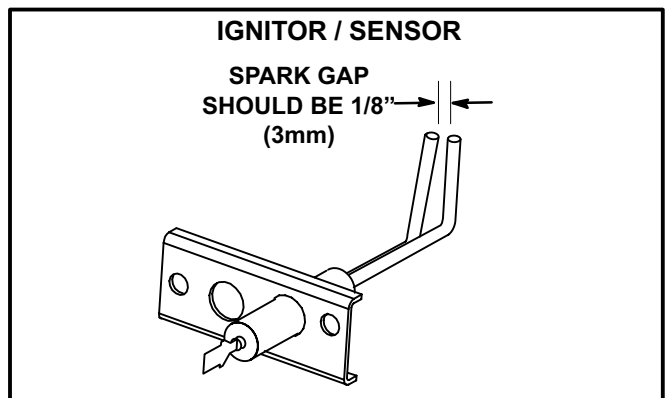

FIGURE 20

- 3- Remove the right burner and check the alignment of the ignition sensor. See figure 21.
- 4- Replace burners and burner support cap. Secure cap in place with retained screws.
- 5- The following manifold pressures are listed on gas valves.
 - Natural Gas Units - Low Fire - 1.6" w.c. (not adjustable)
 - Natural Gas Units - High Fire - 3.7" w.c.
 - LP Gas Units - Low Fire - 5.5" w.c. (not adjustable)
 - LP Gas Units - High Fire - 10.5" w.c.

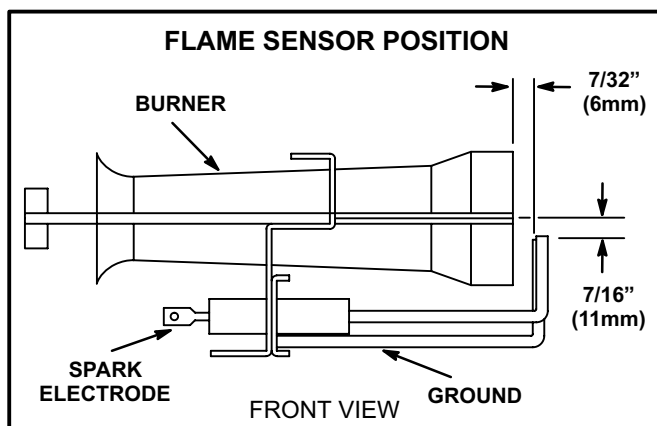

FIGURE 21

Electric Heat Start-Up (LCA Units)

Factory- or Field-Installed Option

Electric heat will stage on and cycle with thermostat demand. Number of stages of electric heat will vary depending on electric heat assembly. See electric heat wiring diagram on unit for sequence of operation.

Service

The unit should be inspected once a year by a qualified service technician.

⚠️ WARNING

Product contains fiberglass wool.

Disturbing the insulation in this product during installation, maintenance, or repair will expose you to fiberglass wool. Breathing this may cause lung cancer. (Fiberglass wool is known to the State of California to cause cancer.)

Fiberglass wool may also cause respiratory, skin, and eye irritation.

To reduce exposure to this substance or for further information, consult material safety data sheets available from address shown below, or contact your supervisor.

P.O. Box 799900
Dallas, TX 75379-9900

⚠️ CAUTION

Label all wires prior to disconnection when servicing controls. Wiring errors can cause improper and dangerous operation. Verify proper operation after servicing.

A-Filters

Units are equipped with twelve 20 X 20 X 2" (508 X 508 X 51mm) filters. Filters should be checked and replaced when necessary with filters of like kind and size. Take note of air flow direction marking on filter frame when reinstalling filters. See figure 22.

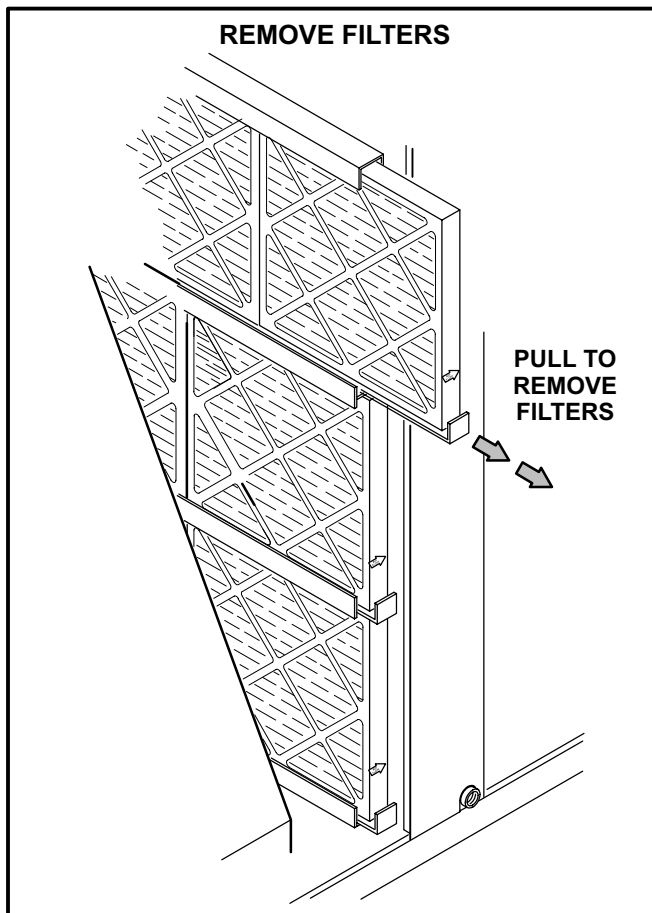

FIGURE 22

NOTE-Filters must be U.L.C. certified or equivalent for use in Canada.

B-Lubrication

All motors are lubricated at the factory. No further lubrication is required.

Blower shaft bearings are prelubricated. For extended bearing life, relubricate at least once every two years with a lithium base grease, such as Alvania 3 (Shell Oil), Chevron BRB2 (Standard Oil) or Regal AFB2 (Texas Oil). Use a hand grease gun for relubrication. Add only enough grease to purge through the bearings so that a bead of grease appears at the seal lip contacts.

C-Burners (Gas Units)

- 1- Periodically examine burner flames for proper appearance during the heating season.
- 2- Before each heating season examine the burners for any deposits or blockage which may have occurred.
- 3- Clean burners as follows:
 - a- Turn off both electrical power and gas supply to unit.
 - b- Open access panel to burner compartment.
 - c- Remove burner retaining bracket and lift burners from orifices.
 - d- Clean as necessary and replace burners. Refit retaining brackets. Make sure that burner heads line up correctly. Spark gap on ignition electrode must be properly set. Refer to Heating Adjustment section. Replace access panel.

⚠ WARNING



Danger of explosion. Can cause injury or death. Do not overtighten main burner mounting screws. Snug tighten only.

- e- Restore electrical power and gas supply. Follow lighting instructions attached to unit and use inspection port in access panel to check flame.

D-Combustion Air Inducer (Gas Units)

A combustion air blower proving switch checks combustion air inducer operation before allowing power to the gas controller. Gas controller will not operate if inducer is obstructed.

Under normal operating conditions, the combustion air inducer wheel should be checked and cleaned prior to the heating season. However, it should be examined periodically during the heating season to establish an ideal cleaning schedule. With power supply disconnected, the condition of the inducer wheel can be determined by looking through the vent opening.

Clean combustion air inducer as follows:

- 1- Shut off power supply and gas to unit.
- 2- Disconnect pressure switch air tubing from combustion air inducer port.
- 3- Remove and retain screws securing combustion air inducer to flue box. Remove and retain two screws from bracket supporting vent connector. See figure 23.
- 4- Clean inducer wheel blades with a small brush and wipe off any dust from housing. Clean accumulated dust from front of flue box cover.
- 5- Return combustion air inducer motor and vent connector to original location and secure with retained screws. It is recommended that the combustion air inducer gasket be replaced during reassembly.

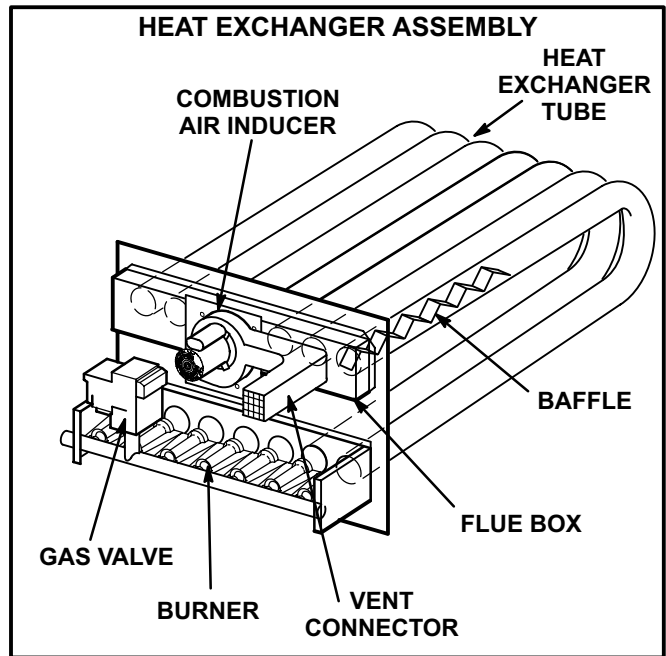

FIGURE 23

- 6- Clean combustion air inlet louvers on heat access panel using a small brush.

E-Flue Passageway and Flue Box (Gas Units)

- 1- Remove combustion air inducer assembly as described in section D.
- 2- Remove flue box cover. Clean with a wire brush as required.
- 3- Remove flue baffle retaining bracket and pull tube baffles from heat exchanger tubes. Clean tubes and baffles with a wire brush.
- 4- Reinsert tube baffles, secure baffle retaining bracket, and reassemble the unit. The flue box cover gasket and combustion air inducer gasket should also be replaced during reassembly.

F-Evaporator Coil

Inspect and clean coil at beginning of each cooling season. Clean using mild detergent or commercial coil cleanser. Flush coil and condensate drain with water taking care not to get insulation, filters and return air ducts wet.

G-Condenser Coil

Clean condenser coil annually with detergent or commercial coil cleaner and inspect monthly during the cooling season. Access panels are provided on front and back of condenser section.

H-Supply Air Blower Wheel

Annually inspect supply air blower wheel for accumulated dirt or dust. Turn off power before attempting to remove access panel or to clean blower wheel.