

INSTALLATION INSTRUCTIONS

⚠ WARNING

Improper installation, adjustment, alteration, service or maintenance can cause property damage, personal injury or loss of life. Installation and service must be performed by a qualified installer, service agency or the gas supplier

LHA090 (7-1/2 TON) LHA102 (8-1/2 TON) LHA120 (10 TON) LHA150 (12-1/2 TON)

Table Of Contents

Dimensions	1
Parts Arrangements	2
Shipping and Packing List	2
General	2
Safety	2
Unit Support	3
Duct Connections	4
Rigging Unit For Lifting	4
Condensate Drains	4

HEAT PUMP UNITS
504,874M
1/2004
Supersedes 503,924M

Factory-Installed Options	5
Electrical Connections	6
Cooling Start-Up	8
Heating Start-Up	9
Blower Operation and Adjustments	9
Service	14

**RETAIN THESE INSTRUCTIONS
FOR FUTURE REFERENCE**

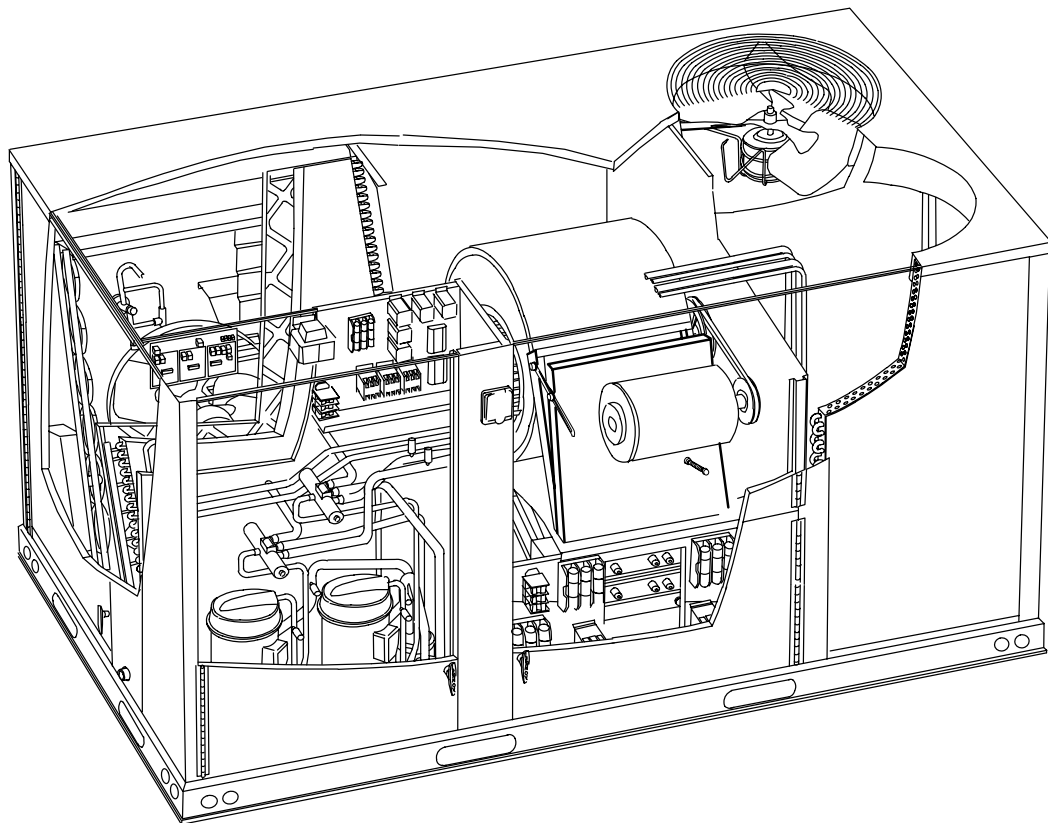

LHA090, 102, 120, & 150 DIMENSIONS

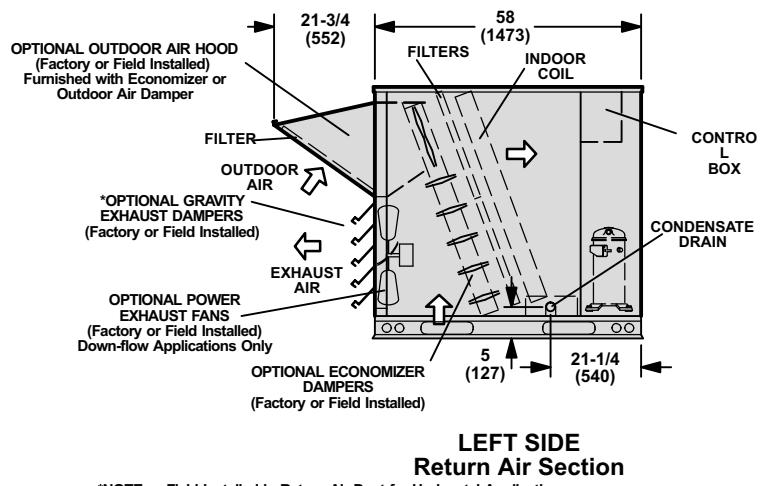
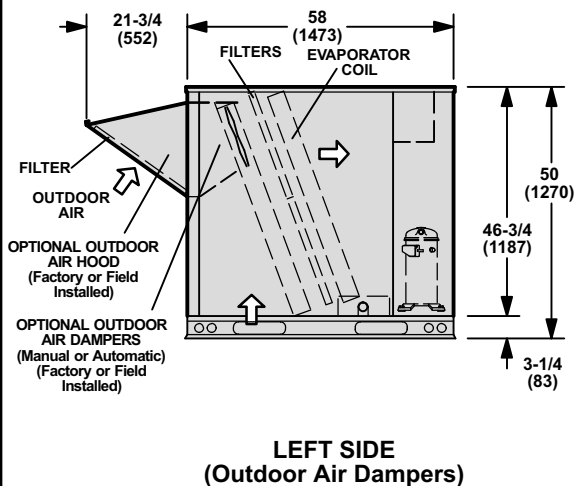
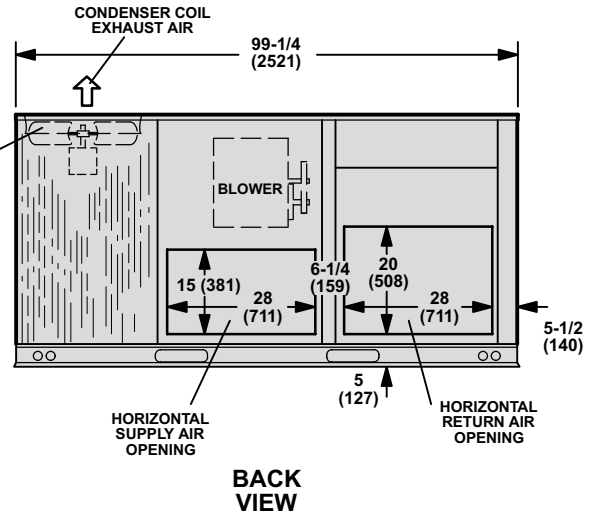
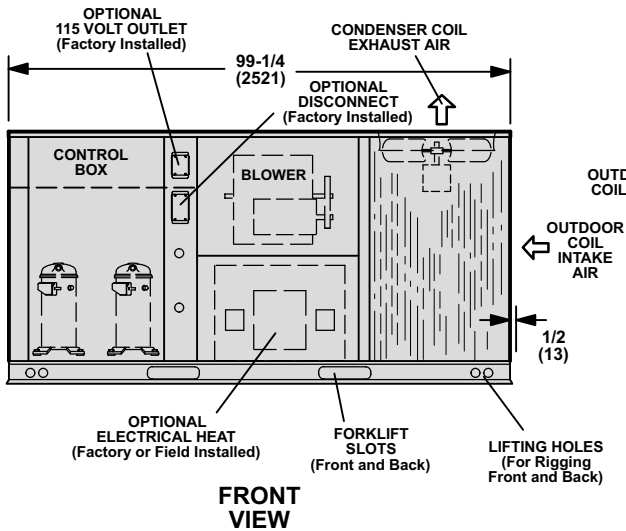
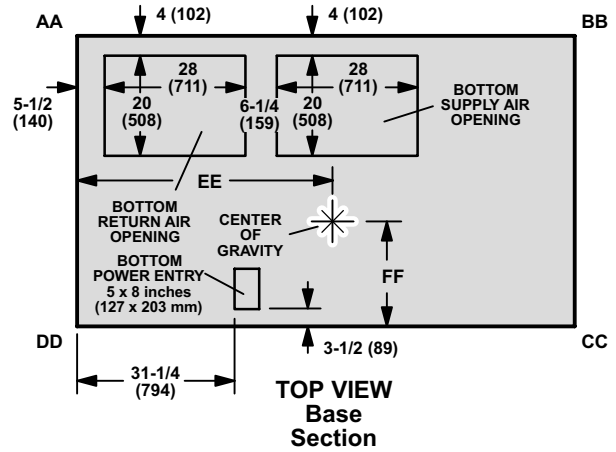
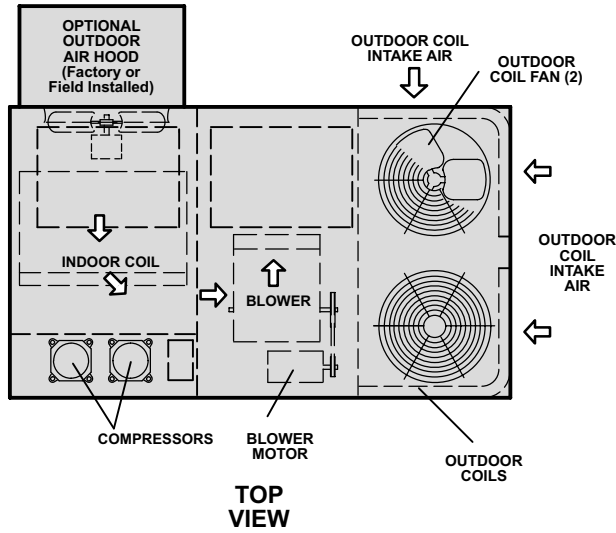

*NOTE — Field Installed in Return Air Duct for Horizontal Applications.

LHA090, 102, 120 & 150 PARTS ARRANGEMENT

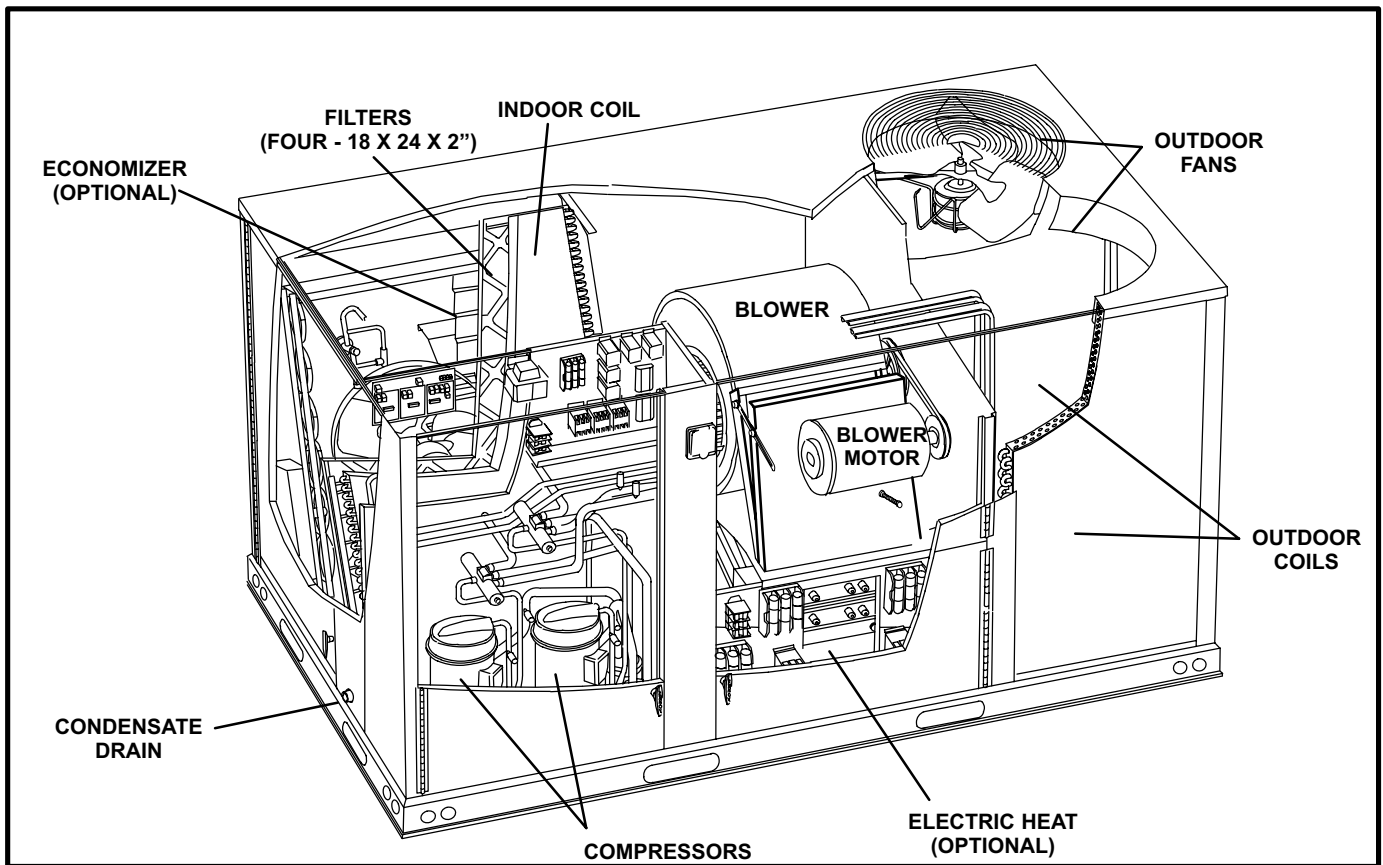

Shipping and Packing List

Package 1 of 1 contains:

- 1- Assembled unit

Check unit for shipping damage. Receiving party should contact last carrier immediately if shipping damage is found.

General

These instructions are intended as a general guide and do not supersede local codes in any way. Authorities having jurisdiction should be consulted before installation.

Safety

The LHA unit is ETL certified for outdoor installations only at the clearances to combustible materials listed on unit nameplate and in figure 1.

Installation of LHA heat pumps must conform with standards in National Fire Protection Association (NFPA) "Standard for Installation of Air Conditioning and Ventilating Systems NFPA No. 90A," "Standard for

Installation of Residence Type Warm Air Heating and Air conditioning Systems NFPA No. 90B," local municipal building codes and manufacturer's installation instructions.

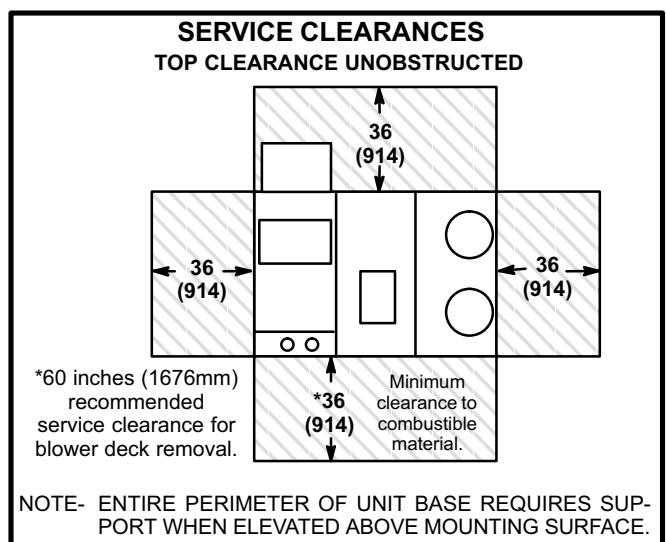

FIGURE 1

The National Electric Code (ANSI/NFPA No. 70-1984) is available from:

National Fire Protection Association
1 Batterymarch Park
P.O. Box 9101
Quincy, MA 02269-9101

The LHA unit is CSA International certified as a heat pump with cooling and with or without auxiliary electric heat for non-residential use only at the clearances to combustible materials as listed on the unit nameplate and in figure 1.

Installation of CSA International certified units must conform with current standard C273.5 "Installation Requirements for Heat Pumps" and applicable local codes. Authorities having jurisdiction should be consulted before installation.

NOTE - These units must not be used as a "construction heater" at any time during any phase of construction. Very low return air temperatures, harmful vapors, and misplacement of the filters will damage the unit and its efficiency.

⚠️ WARNING

Product contains fiberglass wool. Disturbing the insulation in this product during installation, maintenance, or repair will expose you to fiberglass wool. Breathing this may cause lung cancer. (Fiberglass wool is known to the State of California to cause cancer.) Fiberglass wool may also cause respiratory, skin, and eye irritation. To reduce exposure to this substance or for further information, consult material safety data sheets available from address shown on unit nameplate or contact your supervisor.

⚠️ IMPORTANT

The Clean Air Act of 1990 bans the intentional venting of refrigerant (CFC's and HCFC's) as of July 1, 1992. Approved methods of recovery, recycling or reclaiming must be followed. Fines and/or incarceration may be levied for non-compliance.

Unit Support

NOTE - Securely fasten roof frame to roof per local codes.

A-Downflow Discharge Application

Roof Mounting with LARMF10/15

- 1- The LARMF10/15 roof mounting frame must be installed, flashed and sealed in accordance with the instructions provided with the frame.
- 2- The LARMF10/15 roof mounting frame should be square and level to 1/16" per linear foot (5mm per linear meter) in any direction.

- 3- Duct must be attached to the roof mounting frame and not to the LHA unit; supply and return plenums must be installed before setting the unit.

Installer's Roof Mounting Frame

Many types of roof frames can be used to install the LHA unit, depending upon different roof structures. Items to keep in mind when using the building frame or supports are:

- 1- The LHA base is fully enclosed and insulated, so an enclosed frame is not required.
- 2- The frames or supports must be constructed with non-combustible materials and should be square and level to 1/16" per linear foot (5mm per linear meter) in any direction.
- 3- Frame or supports must be high enough to prevent any form of moisture from entering unit. Recommended minimum frame height is 14" (356mm).
- 4- Duct must be attached to the roof mounting frame and not to the LHA unit. Supply and return plenums must be installed before setting the unit.
- 5- Units require support along all four sides of unit base. Supports must be constructed of steel or suitably treated wood materials.

NOTE-When installing an LHA unit on a combustible surface for downflow discharge applications, the LARMF10/15 roof mounting frame is required.

B-Horizontal Discharge Applications

- 1- Units installed in horizontal airflow applications must use a horizontal conversion kit (56K53).
- 2- Specified installation clearances must be maintained when installing LHA units. Refer to figure 1.
- 3- Top of support slab should be at least 4" (102mm) above the finished grade and located so no run-off water from higher ground can collect around the unit.
- 4- Units require support along all four sides of unit base. Supports must be constructed of steel or suitably treated wood materials.

Duct Connection

All exterior ducts, joints, and openings in roof or building walls must be insulated and weatherproofed with flashing and sealing compounds in accordance with applicable codes. Any duct passing through an unconditioned space must be insulated.

⚠ CAUTION

In downflow applications, do not drill or punch holes in base of unit. Leaking in roof may occur if unit base is punctured.

Rigging Unit For Lifting

- 1- Detach wooden base protection before rigging.
- 2- Connect rigging to the unit base using both holes in each corner. See figure 2.
- 3- All panels must be in place for rigging.
- 4- Place field-provided H-style pick in place just above top edge of unit. Frame must be of adequate strength and length. (H-style pick prevents damage to unit.)

LHA UNIT	WEIGHT*	
	LBS.	KG.
090, 102	1390	631
120, 150	1440	653

*Maximum weight with all available factory-installed accessories.

Lifting Point Should Be Directly Above Center Of Gravity.

CAUTION: DO NOT WALK ON UNIT.

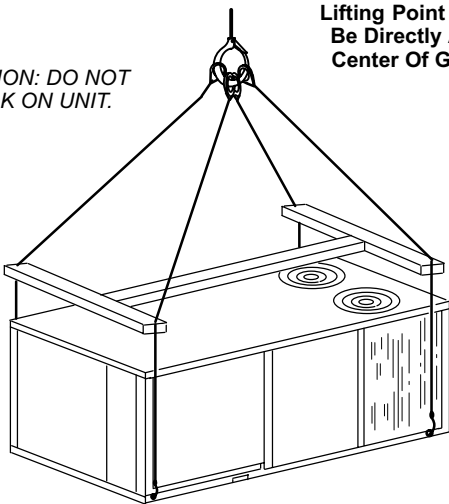

FIGURE 2

Condensate Drains

Make drain connection to the 1" N.P.T. drain nipple provided on unit. A trap must be installed between drain connection and an open vent for proper condensate removal. See figure 3. It is sometimes acceptable to drain condensate onto the roof or grade; however, a tee should be fitted to the trap to direct condensate downward. The condensate line must be vented. Check local codes concerning condensate disposal. Refer to pages 1 and 2 for condensate drain location.

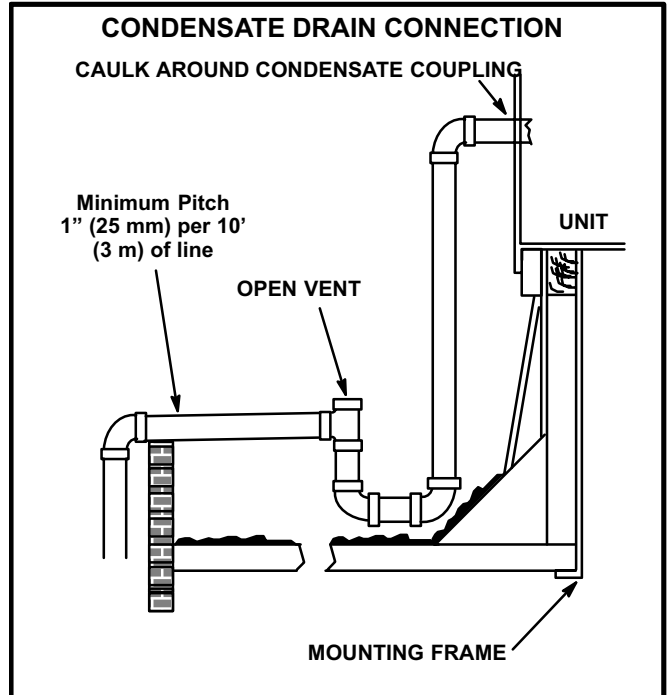

FIGURE 3

Factory-Installed Options

A-Economizer

The A56 EM1 economizer board controls economizer operation and provides potentiometers to control minimum damper position and enthalpy control adjustments. The A56 EM1 economizer board is positioned on the A55 M1 main control board in the unit control box. See the Integrated Modular Control Guide provided with this unit for economizer operation and adjustments.

B-Intake Hood

The intake hood top panel is secured to the unit. The intake hood sides, filters, and three support brackets are shipped unassembled in the blower compartment. Assemble hoods and install as follows:

- 1- Remove screws securing side flanges of top hood to unit. See figure 4.
- 2- Pivot top hood open and secure sides of intake hood to top of hood using three sheet metal screws on each side. See figure 4.

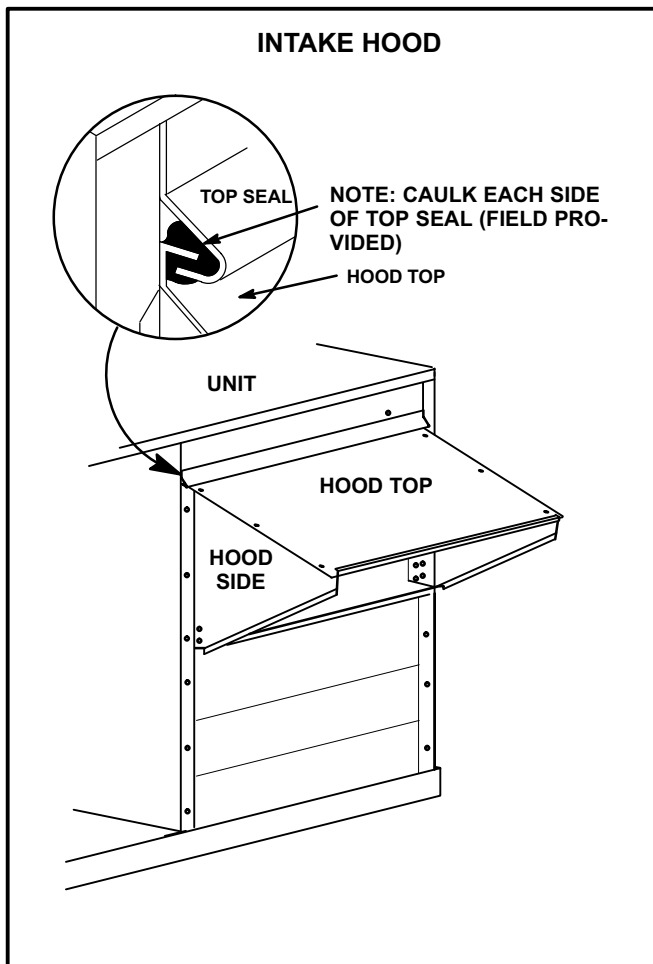

FIGURE 4

- 3- Align two holes on intake hood side panel with two holes on bottom (longer) filter bracket. See figure 5. Secure both sides of bottom filter bracket to hood sides with sheet metal screws.
- 4- Secure intake hood sides to unit.
- 5- Slide two filters into bottom filter bracket. Position filler piece between filters with one end in bottom filter bracket.
- 6- Install top filter bracket as shown in figure 5. Secure with screws provided.

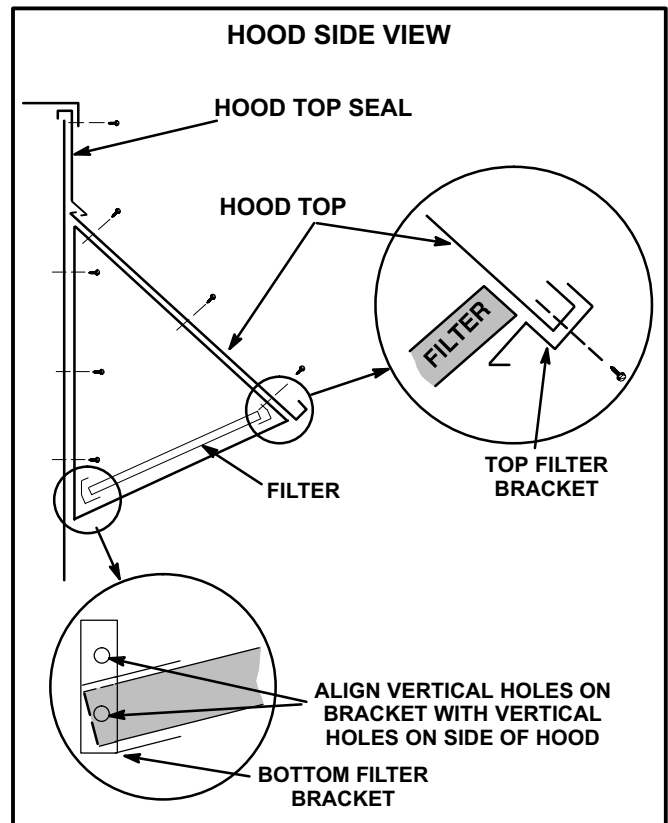

FIGURE 5

Electrical Connections

POWER SUPPLY

Do not apply power or close disconnect switch until installation is complete. Refer to start-up directions. Refer closely to unit wiring diagram. Figure 7 shows a typical unit wiring diagram.

Refer to unit nameplate for minimum circuit ampacity and maximum fuse size.

- 1- 230,460,575 volt units are factory wired. **For 208V supply**, disconnect the orange wire (230V) at control power transformer(s). Reconnect the red wire (208V). Tape the exposed end of the 230V orange wire.
- 2- Route power through the bottom power entry area and connect to TB13 or TB2. If unit contains an optional factory-installed circuit breaker or disconnect switch, connect line voltage to CB10 or S48. See unit wiring diagram.
- 3- *Units With 120v GFCI Outlet-*
Newer model units have factory-wired GFCI outlets. On older model units, connect separate 120v wiring to GFCI outlet pigtails in handy box.

CONTROL WIRING

A standard 2-heat / 2-cool thermostat, not a heat pump thermostat, is specified for use with this unit.

A-Thermostat Location

Room thermostat mounts vertically on a standard 2" X 4" handy box or on any non-conductive flat surface.

Locate thermostat approximately 5 feet (1524 mm) above the floor in an area with good air circulation at average temperature. Avoid locating the room thermostat where it might be affected by:

- drafts or dead spots behind doors and in corners
- hot or cold air from ducts
- radiant heat from sun or appliances
- concealed pipes and chimneys

B-Control Wiring

- 1- Route thermostat cable or wires from subbase through knockout provided in unit. Use 18 AWG wire for all applications using remotely installed electro-mechanical and electronic thermostats.

IMPORTANT - Unless field thermostat wires are rated for maximum unit voltage, they must be routed away from line voltage wiring. Use wire ties located below the IMC board (A55) to secure thermostat cable.

- 2- Install thermostat assembly in accordance with instructions provided with thermostat. See figure 6 for field wiring electronic and electro-mechanical thermostats. If using other temperature control devices or energy management systems see instructions and wiring diagram provided by manufacturer.

IMPORTANT-Terminal connections at the wall plate or subbase must be made securely. Loose control wire connections may allow unit to operate but not with proper response to room demand.

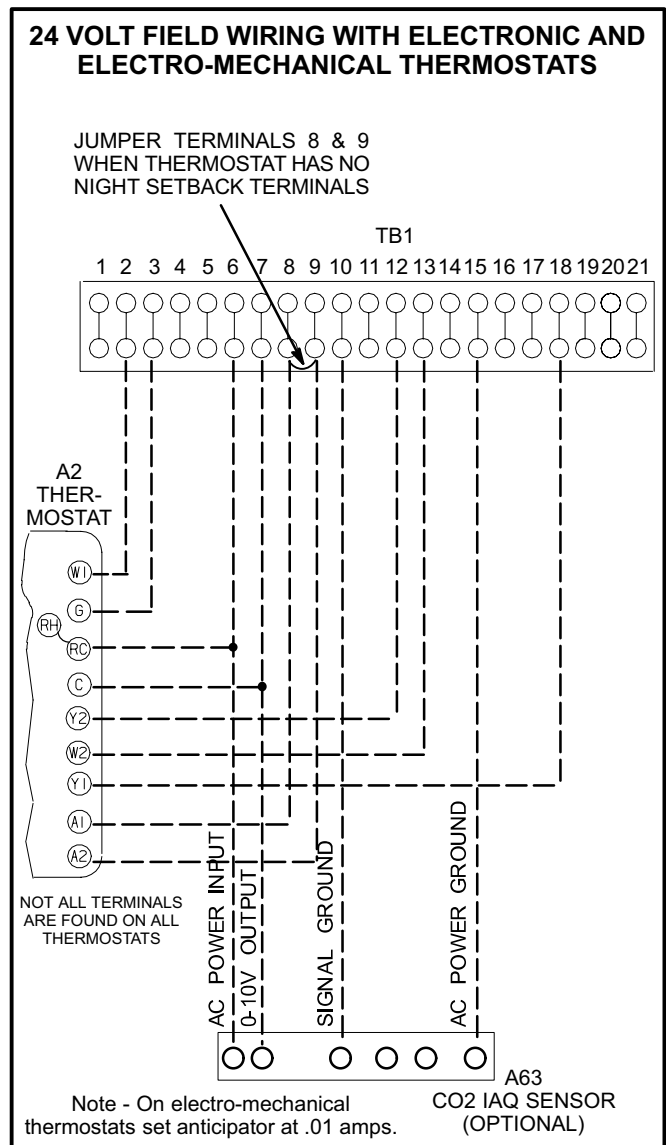
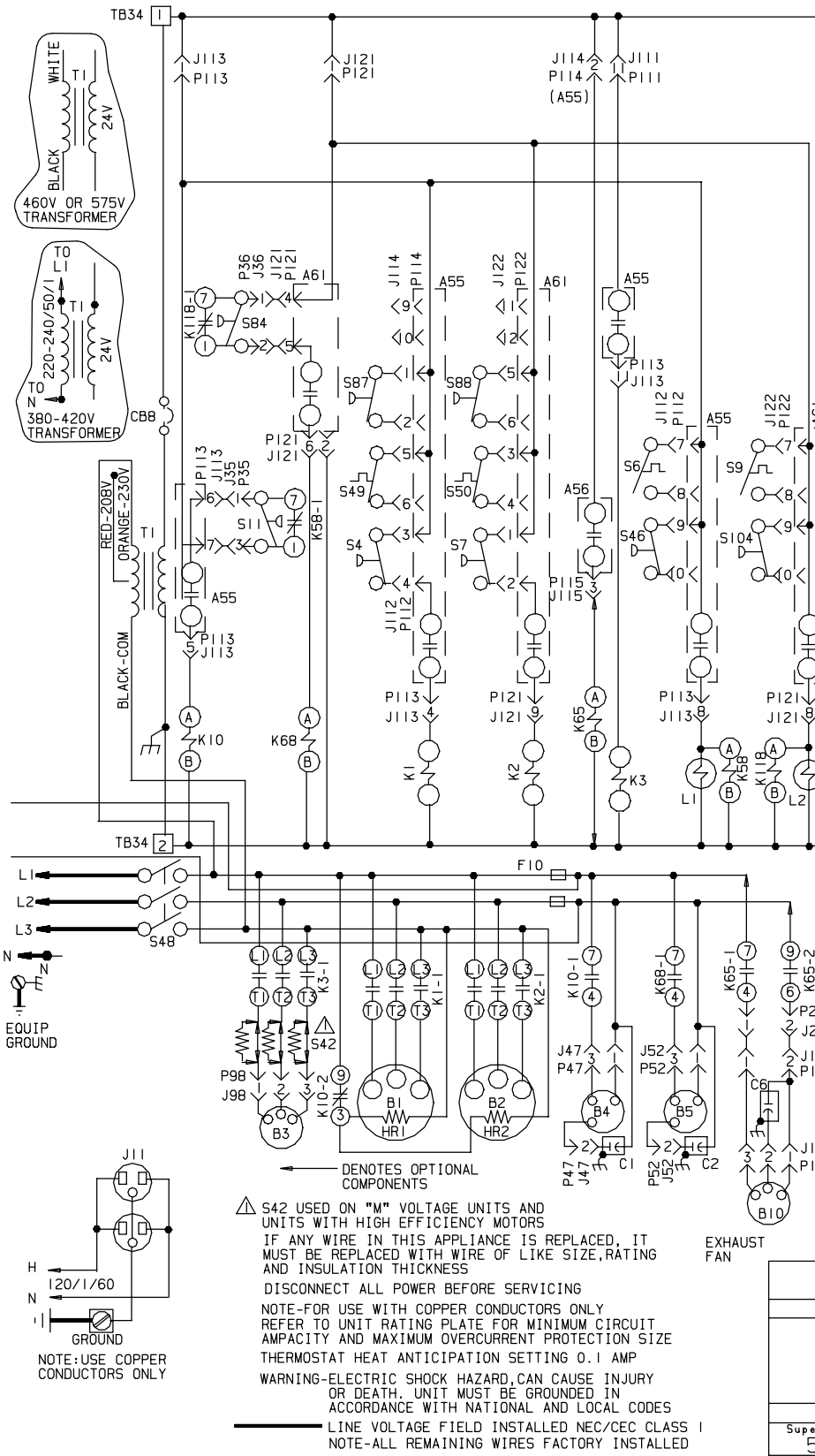

FIGURE 6

TYPICAL LHA UNIT WIRING SCHEMATIC

24V POWER



KEY	DESCRIPTION
A55	PANEL-MAIN
A56	PANEL-ECONOMIZER
A61	PANEL-HEAT PUMP
B1	COMPRESSOR 1
B2	COMPRESSOR 2
B3	MOTOR-BLOWER
B4	MOTOR-OUTDOOR FAN 1
B5	MOTOR-OUTDOOR FAN 2
B10	MOTOR-EXHAUST FAN
C1	CAPACITOR-OUTDOOR FAN 1
C2	CAPACITOR-OUTDOOR FAN 2
C6	CAPACITOR-EXHAUST FAN
CBB	CIRCUIT BREAKER-TRANS T1
F10	FUSE-OUTDOOR FAN MOTOR
HR1	HEATER-COMPRESSOR
HR2	HEATER-COMPRESSOR 2
J11	JACK-GFT RECEPTACLE
J18	JACK-EXHAUST FAN COMPT
J24	JACK-EXHAUST FAN
J35	JACK-TEST HEAT
J36	JACK-TEST COOL
J47	JACK-OUTDOOR FAN 1
J52	JACK-OUTDOOR FAN 2
J98	JACK-BLOWER DECK
J111	JACK-GAS 1 OUTPUT
J112	JACK-COOLING SENSOR INPUT
J113	JACK-BLOWER & COOL 1 CONTROL
J114	JACK-SENSOR INPUT
J115	JACK-ECONOMIZER OUTPUT
J121	JACK-HEAT PUMP CONTROL
J122	JACK-HEAT PUMP INPUT
J132	JACK-B10 EXHAUST FAN MOTOR
K1,-1	CONTACTOR-COMPRESSOR 1
K2,-1	CONTACTOR-COMPRESSOR 2
K3,-1,2	CONTACTOR-BLOWER RELAY
K10,-1,2	RELAY-OUTDOOR FAN 1
K58,-1	RELAY-LOW AMBIENT KIT
K65,-1,2	RELAY-EXHAUST FAN
K68,-1	RELAY-OUTDOOR FAN 2
K118,-1	RELAY-LOW AMBIENT KIT,COMP 2
L1	VALVE-REVERSING 1
L2	VALVE-REVERSING 2
P18	PLUG-EXHAUST FAN COMPT
P24	PLUG-EXHAUST FAN
P35	PLUG-TEST HEAT
P36	PLUG-TEST COOL
P47	PLUG-OUTDOOR FAN 1
P52	PLUG-OUTDOOR FAN 2
P98	PLUG-BLOWER DECK
P111	PLUG-GAS 1 OUTPUT
P112	PLUG-COOLING SENSOR

KEY	DESCRIPTION
P113	PLUG-BLWR & COOL 1 CONT
P114	PLUG-SENSOR INPUT
P115	PLUG-ECONOMIZER OUTPUT
P116	PLUG-COMPRESSOR 2
P121	JACK-HEAT PUMP CONTROL
P122	JACK-HEAT PUMP INPUT
P132	PLUG-B10 EXHAUST FAN MOTOR
S4	SWITCH-LIMIT, HI PRESS, COMP 1
S7	SWITCH-LIMIT, HI PRESS, COMP 2
S9	SWITCH-DEFROST, COMP 2
S11	SWITCH-LOW PRESS, LOW AMB KIT
S42	OVERLOAD-RELAY, BLWR MOTOR
S46	SWITCH-DEFROST TERMINATION
S48	SWITCH-DISCONNECT
S49	SWITCH-FREEZESTAT, COMP 1
S50	SWITCH-FREEZESTAT, COMP 2
S84	SWITCH-LOW PRESS, LOW AMB, COMP 2
S87	SWITCH-LOW PRESS, COMP 1
S88	SWITCH-LOW PRESS, COMP 2
S104	SWITCH-DEFROST PRESS, COMP 2
T1	TRANSFORMER-CONTROL
TB34	TERMINAL STRIP-TRANS T1

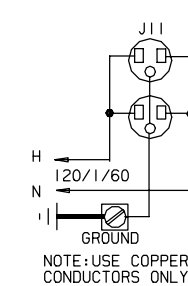
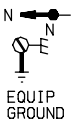

△ S42 USED ON "M" VOLTAGE UNITS AND UNITS WITH HIGH EFFICIENCY MOTORS
 IF ANY WIRE IN THIS APPLIANCE IS REPLACED, IT MUST BE REPLACED WITH WIRE OF LIKE SIZE, RATING AND INSULATION THICKNESS
 DISCONNECT ALL POWER BEFORE SERVICING
 NOTE-FOR USE WITH COPPER CONDUCTORS ONLY REFER TO UNIT RATING PLATE FOR MINIMUM CIRCUIT AMPACITY AND MAXIMUM OVERCURRENT PROTECTION SIZE
 THERMOSTAT HEAT ANTICIPATION SETTING 0.1 AMP
 WARNING-ELECTRIC SHOCK HAZARD, CAN CAUSE INJURY OR DEATH. UNIT MUST BE GROUNDED IN ACCORDANCE WITH NATIONAL AND LOCAL CODES
 — LINE VOLTAGE FIELD INSTALLED NEC/CEC CLASS 1
 NOTE-ALL REMAINING WIRES FACTORY INSTALLED

WIRING DIAGRAM		9/96
HEAT PUMP-PACKAGED		
LHA-090, 120-1-G, J, M, Y		
HEAT PUMP SECTION B14		
Supersedes Form No.		New Form No.
531,070W		531,963W
©1996 Lennox Industries Inc.		Litho U.S.A.

FIGURE 7
Page 7

Cooling Start-Up

IMPORTANT-Crankcase heaters must be energized for 24 hours before attempting to start compressor. Set thermostat so there is no demand to prevent compressors from cycling. Apply power to unit.

NOTE - These units must not be used as a “construction heater” at any time during any phase of construction. Very low return air temperatures, harmful vapors, and misplacement of the filters will damage the unit and its efficiency. Additionally, a unit which will be subject to cold temperatures when not in operation must have a vapor barrier installed to seal the duct connections. Failure to protect the unit from moisture laden air or harmful vapors (generated from the construction process and temporary combustion heating equipment) will cause corrosive condensation within the unit. Failure to properly protect the unit in this situation will cause electrical and electronic component failure and could affect the unit warranty status.

A-Preliminary Checks

- 1- Make sure that unit is installed in accordance with the installation instructions and applicable codes.
- 2- Inspect all electrical wiring, both field and factory installed, for loose connections. Tighten as required.
- 3- Check to ensure that refrigerant lines do not rub against the cabinet or against other refrigerant lines.
- 4- Check voltage at disconnect switch. Voltage must be within range listed on nameplate. If not, consult power company and have voltage condition corrected before starting unit.
- 5- Make sure filters are in place before start-up.

B-Start-Up

- 1- Set thermostat or temperature control device fan switch to **AUTO** or **ON**. Set thermostat or temperature control device to initiate a first-stage cooling demand.

A first-stage (Y1) cooling demand will energize compressor 1. An increased cooling demand (Y2) will initiate compressor 2.

Units With Optional Economizer -

The optional economizer will start on a first stage (Y1) cooling demand when outdoor air enthalpy is suitable. An increased cooling demand (Y2) will energize compressors 1 and 2.

- 2- Refrigerant circuits are factory charged with HCFC-22 refrigerant. See unit rating plate for correct amount of charge.
- 3- Units contain two refrigerant circuits or systems. See figure 8.

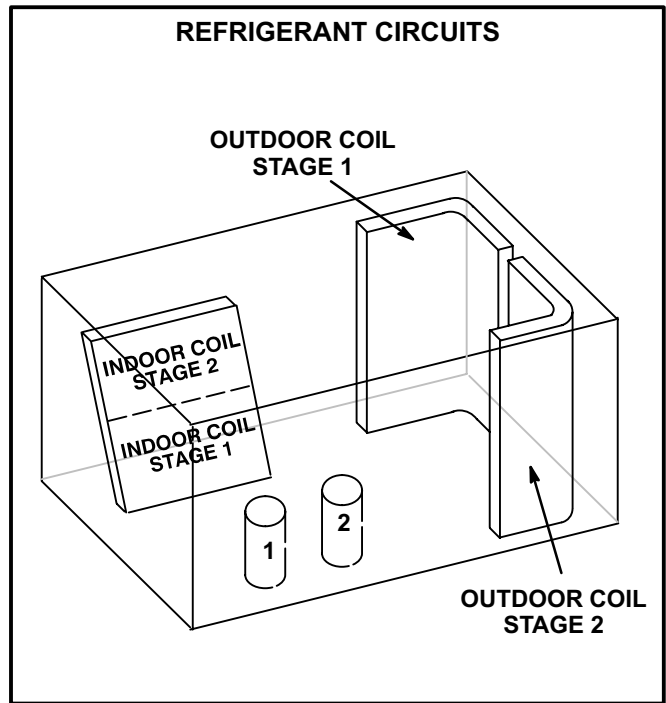

FIGURE 8

C-Refrigerant Charge and Check

WARNING-Do not exceed nameplate charge under any condition.

This unit is factory charged and should require no further adjustment. If the system requires charge, reclaim the charge, evacuate the system, and add required nameplate charge.

NOTE - System charging is not recommended below 60°F (15°C). In temperatures below 60°F (15°C), the charge **must** be weighed into the system.

If weighing facilities are not available, or to check the charge, use the following procedure:

- 1- Attach gauge manifolds and operate unit in cooling mode until system stabilizes (approximately five minutes). Make sure outdoor air dampers are closed.
- 2- Check each system separately with all stages operating.
- 3- Use a thermometer to accurately measure the outdoor ambient temperature.
- 4- Apply the outdoor temperature to tables 1 through 4 to determine normal operating pressures.
- 5- Compare the normal operating pressures to the pressures obtained from the gauges. Minor variations in these pressures may be expected due to differences in installations. Significant differences could mean that the system is not properly charged or that a problem exists with some component in the system. **Correct any system problems before proceeding.**

**TABLE 1
LHA090H NORMAL OPERATING PRESSURES**

Outdoor Coil Entering Air Temp	CIRCUIT 1		CIRCUIT 2	
	Dis. ± 10 psig	Suct. ± 5 psig	Dis. ± 10 psig	Suct. ± 5 psig
65°F	Outdoor Fan Cycles at 65°F			
75°F	180	82	178	77
85°F	210	83	210	79
95°F	240	84	242	81
105°F	280	85	277	83
115°F	300	86	310	85

**TABLE 2
LHA102H NORMAL OPERATING PRESSURES**

Outdoor Coil Entering Air Temp	CIRCUIT 1		CIRCUIT 2	
	Dis. ± 10 psig	Suct. ± 5 psig	Dis. ± 10 psig	Suct. ± 5 psig
65°F	156	77	154	77
75°F	185	78	185	78
85°F	215	80	216	79
95°F	244	81	247	80
105°F	273	82	277	82
115°F	303	83	309	83

**TABLE 3
LHA120H NORMAL OPERATING PRESSURES**

Outdoor Coil Entering Air Temp	CIRCUIT 1		CIRCUIT 2	
	Dis. ± 10 psig	Suct. ± 5 psig	Dis. ± 10 psig	Suct. ± 5 psig
65°F	166	77	166	75
75°F	196	78	196	76
85°F	228	80	228	78
95°F	260	82	260	79
105°F	290	84	290	81
115°F	321	85	321	82

**TABLE 4
LHA150S NORMAL OPERATING PRESSURES**

Outdoor Coil Entering Air Temp	CIRCUIT 1		CIRCUIT 2	
	Dis. ± 10 psig	Suct. ± 5 psig	Dis. ± 10 psig	Suct. ± 5 psig
65°F	150	77	148	76
75°F	178	78	176	77
85°F	207	80	208	79
95°F	236	81	240	81
105°F	266	83	270	83
115°F	295	84	300	84

6- If discharge pressure is high, remove refrigerant from the system. If discharge pressure is low, add refrigerant to the system.

- Add or remove charge in increments.
- Allow the system to stabilize each time refrigerant is added or removed.

7- Use the following approach method along with the normal operating pressures to confirm readings.

D-Charge Verification - Approach Method

8- Using the same thermometer, compare liquid temperature to outdoor ambient temperature.

Approach Temperature = Liquid temperature minus ambient temperature.

9- Approach temperature should match values in table 5. An approach temperature greater than value shown indicates an undercharge. An approach temperature less than value shown indicates an overcharge.

10- Do not use the approach method if system pressures do not match pressures in tables 1 through 4. The approach method is not valid for grossly over or undercharged systems.

**TABLE 5
APPROACH TEMPERATURES**

LHA Unit	Liquid Temp. Minus Ambient Temp.	
	1st Stage	2nd Stage
090H	7°F ± 1 (3.9°C ± 0.5)	8°F ± 1 (4.4°C ± 0.5)
102H	10°F ± 1 (5.6°C ± 0.5)	8°F ± 1 (4.4°C ± 0.5)
120H	9°F ± 1 (5.0°C ± 0.5)	11°F ± 1 (6.1°C ± 0.5)
150S	9°F ± 1 (5.0°C ± 0.5)	8°F ± 1 (4.4°C ± 0.5)

E-Compressor Controls

1- High Pressure Switches (S4, S7)
Compressor circuits are protected by a high pressure switch which cuts out at 410 psig ± 10 psig (2825 kPa ± 70 kPa).

2- Low Pressure Switches (S87, S88)
The compressor circuits are protected by loss of charge switches. Switches cut out at 25 psig (172 kPa) and automatically reset at 55 psig (379 kPa).

3- Crankcase Heaters (HR1, HR2)
The compressors contain a belly band compressor oil heater which must be on 24 hours before running compressors. Energize by setting thermostat so that there is no cooling demand, to prevent compressor from cycling, and apply power to unit.

4- Low Ambient Pressure Switches (S11, S84)
Switches maintain adequate discharge pressure during low ambient conditions by de-energizing outdoor fans when liquid pressure falls below 150 psig.

During normal ambient conditions, outdoor fan 1 cycles with a Y1 cooling demand and outdoor fan 2 cycles with a Y2 cooling demand. (Fan 1 is on the back side of the unit and fan 2 is on the front side).

The A55 controller cycles outdoor fan 1 via S11 pressure switch and K10 outdoor fan relay. The A55 controller cycles outdoor fan 2 via S84 pressure switch and K68 outdoor fan relay.

- 5- Low Ambient Relay (K58, K118)
During heating operation, relays prevent S11 and S84 fan cycling.
- 6- Freezestats (S49, S50)
Switches de-energize compressors when indoor coil temperature falls below 29°F (-2°C) to prevent coil freeze-up. Switches reset when indoor coil temperature reaches 58°F (15°C).
- 7- Defrost Switches (S6, S9)
Defrost switches close to initiate defrost when outdoor coil suction temperature falls to 35°F (1.7°C).
- 8- Defrost Termination Switches (S46, S104)
Defrost pressure switches open to terminate defrost when suction (discharge pressure during cooling and defrost) pressure reaches 275 psig (1096 kPa).

Heating Start-Up

- 1- Set thermostat or temperature control device to initiate a first-stage heating demand.

A first-stage heating demand (W1) will energize compressors 1 and 2. Both outdoor fans are energized with a W1 demand.

LHA Units With Optional Electric Heat -
An increased heating demand (W2) will energize electric heat.

Blower Operation and Adjustments

A-Blower Operation

- 1- Set thermostat or temperature control device fan switch to **AUTO** or **ON**. With fan switch in **ON** position, blower will operate continuously. With fan switch in **AUTO** position, the blower will cycle with demand.
- 2- Blower and entire unit will be off when thermostat or temperature control device system switch is in **OFF** position.

B-Blower Access

The blower assembly is secured to a sliding base which allows the entire assembly to be pulled out of the unit. See figure 9.

- 1- Disconnect blower motor jack J98 from blower motor plug P98. Disconnect any optional component jack/plugs located on blower sliding assembly base.
- 2- Remove two screws on either side of sliding base. Pull base toward outside of unit.

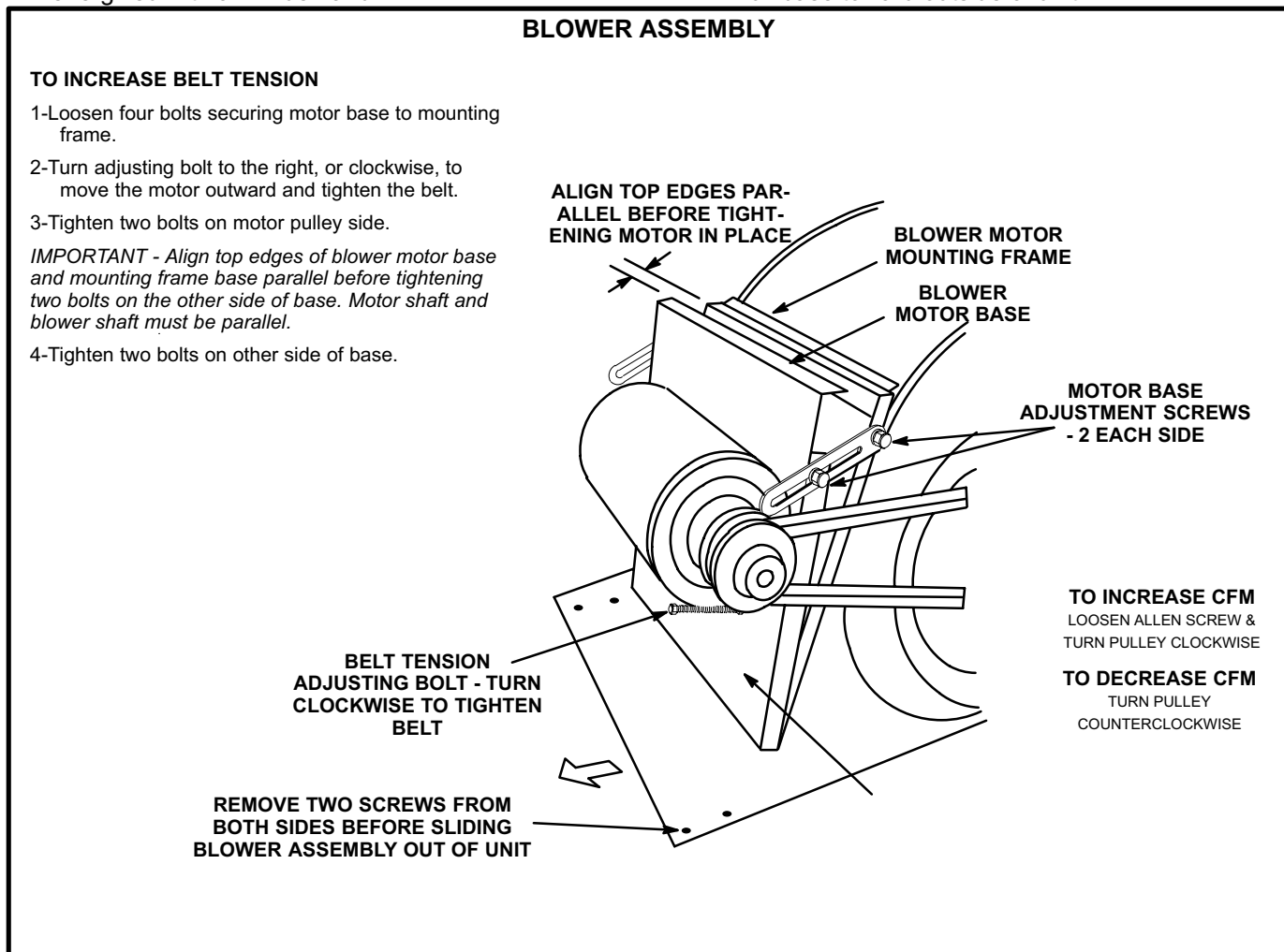

FIGURE 9
Page 10

C-Determining Unit CFM

- 1- The following measurements must be made with a dry indoor coil and with air filters in place. Run blower without a cooling demand. Measure the indoor blower shaft RPM.
- 2- With all access panels in place, measure static pressure external to unit (from supply to return).
- 3- Referring to table 7, use static pressure and RPM readings to determine unit CFM. Use table 8 when installing units with any of the optional accessories listed.
- 4- The blower RPM can be adjusted at the motor pulley. Loosen Allen screw and turn adjustable pulley clockwise to increase CFM. Turn counterclockwise to decrease CFM. See figure 9. Do not exceed minimum and maximum number of pulley turns as shown in table 6.

**TABLE 6
MINIMUM AND MAXIMUM PULLEY ADJUSTMENT**

Belt	Minimum Turns Open	Maximum Turns Open
A Section	0	5
B Section	1*	6

*No minimum turns open when B belt is used on pulleys 6" O.D. or larger.

D-Blower Belt Adjustment

Maximum life and wear can be obtained from belts only if proper pulley alignment and belt tension are maintained. Tension new belts after a 24-48 hour period of operation. This will allow belt to stretch and seat grooves. Make sure blower and motor pulley are aligned as shown in figure 10.

- 1- Loosen four bolts securing motor base to mounting frame. See figure 9.
- 2- *To increase belt tension -*
Turn adjusting bolt to the right, or clockwise, to move the motor outward and tighten the belt. This increases the distance between the blower motor and the blower housing.

To loosen belt tension -
Turn the adjusting bolt to the left, or counterclockwise to loosen belt tension.
- 3- Tighten two bolts on motor pulley side.

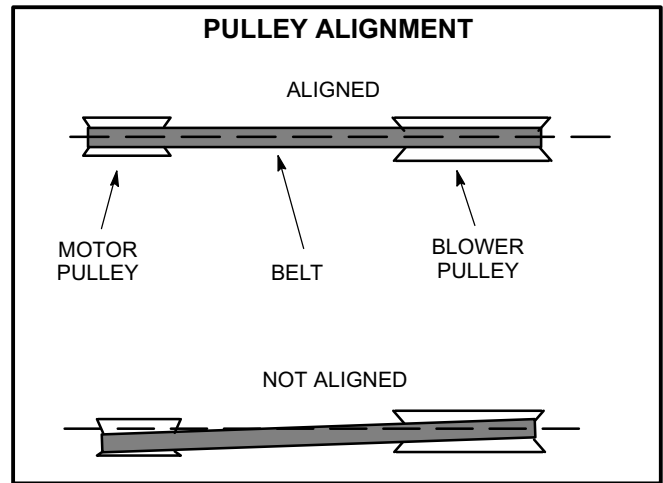

FIGURE 10

IMPORTANT - Align top edges of blower motor base and mounting frame base parallel before tightening two bolts on the other side of base. Motor shaft and blower shaft must be parallel.

- 4- Tighten two bolts on other side of base.

E-Check Belt Tension

Overtensioning belts shortens belt and bearing life. Check belt tension as follows:

- 1- Measure span length X. See figure 11.
- 2- Apply perpendicular force to center of span (X) with enough pressure to deflect belt 1/64" for every inch of span length or 1.5mm per 100mm of span length.
Example: Deflection distance of a 40" span would be 40/64" or 5/8".
Example: Deflection distance of a 400mm span would be 6mm.
- 3- Measure belt deflection force. For a used belt, the deflection force should be 5 lbs. (35kPa). A new belt deflection force should be 7 lbs. (48kPa).
A force below these values indicates an undertensioned belt. A force above these values indicates an overtensioned belt.

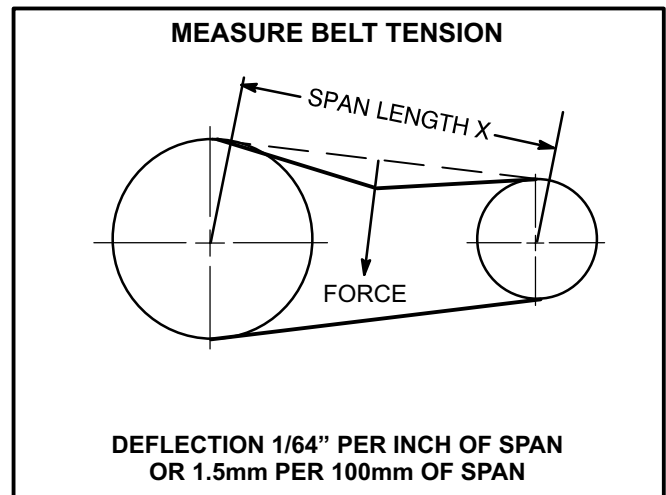

FIGURE 11

**TABLE 7
BASE UNIT BLOWER PERFORMANCE**

**BLOWER TABLE INCLUDES RESISTANCE FOR 102 BASE UNIT ONLY WITH DRY INDOOR COIL & AIR FILTERS IN PLACE.
FOR ALL UNITS ADD:**

- 1 - Wet indoor coil air resistance of selected unit.
- 2 - Any factory installed options air resistance (heat section, economizer, etc.)
- 3 - Any field installed accessories air resistance (duct resistance, diffuser, etc.)

Then determine from blower table blower motor output and drive required.

See table 8 for wet coil and option/accessory air resistance data.

MINIMUM AIR VOLUME REQUIRED FOR USE WITH OPTIONAL ELECTRIC HEAT

- 090/102 requires 3000 cfm (1415 L/s) minimum air with electric heat.
- 120/150 models require 4000 cfm (1890 L/s) minimum air with electric heat.

BOLD ITALIC INDICATES FIELD FURNISHED DRIVE

Air Volume cfm (L/s)	Total Static Pressure - in. w.g. (Pa)												
	.20 (50)	.40 (100)	.60 (150)	.80 (200)	1.00 (250)	1.20 (300)	1.40 (350)	1.60 (400)	1.80 (450)	2.00 (495)	2.20 (545)	2.40 (595)	2.60 (645)
	RPM BHP (kW)	RPM BHP (kW)	RPM BHP (kW)	RPM BHP (kW)	RPM BHP (kW)	RPM BHP (kW)	RPM BHP (kW)	RPM BHP (kW)	RPM BHP (kW)	RPM BHP (kW)	RPM BHP (kW)	RPM BHP (kW)	RPM BHP (kW)
2250 (1060)	455 0.30 <i>(0.22)</i>	555 0.45 <i>(0.34)</i>	640 0.60 <i>(0.45)</i>	720 0.80 (0.60)	790 1.00 (0.75)	855 1.20 (0.90)	915 1.40 (1.04)	975 1.60 (1.19)	1030 1.85 (1.38)	1080 2.05 (1.53)	1130 2.30 (1.72)	1175 2.55 (1.90)	1220 2.80 (2.09)
2500 (1180)	475 0.40 <i>(0.30)</i>	575 0.55 <i>(0.41)</i>	660 0.70 <i>(0.52)</i>	735 0.90 (0.67)	805 1.10 (0.82)	870 1.30 (0.97)	930 1.55 (1.16)	985 1.75 (1.31)	1040 2.00 (1.49)	1090 2.25 (1.68)	1140 2.50 (1.87)	1185 2.75 (2.05)	1230 3.00 (2.24)
2750 (1300)	495 0.45 <i>(0.34)</i>	595 0.65 <i>(0.48)</i>	675 0.85 <i>(0.63)</i>	750 1.05 (0.78)	820 1.25 (0.93)	885 1.45 (1.08)	940 1.70 (1.27)	995 1.90 (1.42)	1050 2.20 (1.64)	1100 2.45 (1.83)	1145 2.65 (1.98)	1195 2.95 (2.20)	1240 3.25 (2.42)
3000 (1415)	525 0.55 <i>(0.41)</i>	615 0.75 <i>(0.56)</i>	695 0.95 (0.71)	770 1.20 (0.90)	835 1.40 (1.04)	895 1.60 (1.19)	955 1.85 (1.38)	1010 2.10 (1.57)	1060 2.35 (1.75)	1110 2.65 (1.98)	1160 2.90 (2.16)	1205 3.20 (2.39)	1250 3.45 (2.57)
3250 (1535)	550 0.65 <i>(0.48)</i>	640 0.90 <i>(0.67)</i>	715 1.10 (0.82)	790 1.35 (1.01)	855 1.60 (1.19)	915 1.80 (1.34)	970 2.05 (1.53)	1025 2.35 (1.75)	1075 2.60 (1.94)	1125 2.85 (2.13)	1170 3.15 (2.35)	1215 3.40 (2.54)	1260 3.70 (2.76)
3500 (1650)	580 0.80 <i>(0.60)</i>	665 1.05 <i>(0.78)</i>	740 1.25 (0.93)	810 1.50 (1.12)	870 1.75 (1.31)	930 2.00 (1.49)	985 2.25 (1.68)	1040 2.55 (1.90)	1090 2.85 (2.13)	1135 3.10 (2.31)	1185 3.40 (2.54)	1230 3.70 (2.76)	1270 4.00 (2.98)
3750 (1770)	605 0.95 <i>(0.71)</i>	690 1.20 (0.90)	760 1.45 (1.08)	830 1.70 (1.27)	890 1.95 (1.45)	950 2.25 (1.68)	1005 2.50 (1.87)	1055 2.80 (2.09)	1105 3.10 (2.31)	1150 3.35 (2.50)	1195 3.65 (2.72)	1240 3.95 (2.95)	1285 4.30 (3.21)
4000 (1890)	635 1.10 <i>(0.82)</i>	715 1.40 (1.04)	785 1.65 (1.23)	850 1.90 (1.42)	910 2.20 (1.64)	965 2.45 (1.83)	1020 2.75 (2.05)	1070 3.05 (2.28)	1120 3.35 (2.50)	1165 3.65 (2.72)	1210 3.95 (2.95)	1255 4.30 (3.21)	1295 4.60 (3.43)
4250 (2005)	665 1.30 <i>(0.97)</i>	740 1.60 (1.19)	810 1.85 (1.38)	870 2.15 (1.60)	930 2.45 (1.83)	985 2.75 (2.05)	1040 3.05 (2.28)	1090 3.35 (2.50)	1135 3.65 (2.72)	1185 4.00 (2.98)	1225 4.30 (3.21)	1270 4.65 (3.47)	1310 4.95 (3.69)
4500 (2125)	695 1.50 (1.12)	770 1.80 (1.34)	835 2.10 (1.57)	895 2.40 (1.79)	955 2.70 (2.01)	1005 3.00 (2.24)	1060 3.35 (2.50)	1105 3.65 (2.72)	1155 4.00 (2.98)	1200 4.30 (3.21)	1245 4.65 (3.47)	1285 5.00 (3.73)	1325 5.30 (3.95)
4750 (2240)	725 1.75 (1.31)	795 2.05 (1.53)	860 2.40 (1.79)	920 2.70 (2.01)	975 3.00 (2.24)	1030 3.35 (2.50)	1080 3.65 (2.72)	1125 3.95 (2.95)	1175 4.35 (3.25)	1215 4.65 (3.47)	1260 5.00 (3.73)	1300 5.35 (3.99)	1340 5.70 (4.25)
5000 (2360)	760 2.05 (1.53)	825 2.35 (1.75)	885 2.65 (1.98)	945 3.00 (2.24)	1000 3.35 (2.50)	1050 3.65 (2.72)	1100 4.00 (2.98)	1145 4.35 (3.25)	1190 4.70 (3.51)	1235 5.05 (3.77)	1280 5.45 (4.07)	----	----
5250 (2475)	790 2.30 (1.72)	855 2.65 (1.98)	910 2.95 (2.20)	970 3.35 (2.50)	1020 3.65 (2.72)	1070 4.00 (2.98)	1120 4.35 (3.25)	1165 4.70 (3.51)	1210 5.10 (3.80)	1255 5.45 (4.07)	----	----	----
5500 (2595)	820 2.60 (1.94)	880 2.95 (2.20)	940 3.30 (2.46)	995 3.70 (2.76)	1045 4.05 (3.02)	1095 4.40 (3.28)	1145 4.80 (3.58)	1190 5.15 (3.84)	1230 5.50 (4.10)	----	----	----	----
5750 (2715)	850 2.95 (2.20)	910 3.30 (2.46)	965 3.70 (2.76)	1020 4.05 (3.02)	1070 4.45 (3.32)	1120 4.80 (3.58)	1165 5.20 (3.88)	1210 5.60 (4.18)	----	----	----	----	----
6000 (2830)	885 3.35 (2.50)	940 3.70 (2.76)	995 4.10 (3.06)	1045 4.45 (3.32)	1095 4.85 (3.62)	1145 5.25 (3.92)	1190 5.65 (4.21)	----	----	----	----	----	----

F-Field-Furnished Blower Drives

For field-furnished blower drives, use tables 7 and 8 to determine BHP and RPM required. Reference table 9 to determine the drive number and table 10 to determine the manufacturer's model number.

**TABLE 8
FACTORY INSTALLED OPTIONS/FIELD INSTALLED ACCESSORY AIR RESISTANCE**

Air Volume		Wet Indoor Coil		Electric Heat	Economizer
cfm	L/s	090, 102	120, 150		
2250	1060	.06 (15)	.10 (25)	.01 (2)	.035 (9)
2500	1180	.08 (20)	.12 (30)	.01 (2)	.04 (10)
2750	1300	.09 (22)	.14 (35)	.01 (2)	.045 (11)
3000	1415	.10 (25)	.16 (40)	.02 (5)	.05 (12)
3250	1535	.11 (27)	.19 (47)	.02 (5)	.06 (15)
3500	1650	.13 (32)	.21 (52)	.03 (7)	.07 (17)
3750	1770	.14 (35)	.23 (57)	.03 (7)	.075 (19)
4000	1890	.16 (40)	.26 (65)	.04 (10)	.08 (20)
4250	2005	.17 (42)	.28 (70)	.04 (10)	.09 (22)
4500	2125	.18 (45)	.31 (77)	.05 (12)	.10 (25)
4750	2240	.20 (50)	.33 (82)	.05 (12)	.11 (27)
5000	2360	.22 (55)	.36 (90)	.06 (15)	.12 (30)
5250	2475	.24 (60)	.39 (97)	.06 (15)	.13 (32)
5500	2595	.26 (65)	.42 (104)	.07 (17)	.14 (35)
5750	2715	.28 (70)	.45 (112)	.07 (17)	.15 (37)
6000	2830	.30 (75)	.68 (169)	.08 (20)	.16 (40)

**TABLE 9
FACTORY INSTALLED DRIVE KIT SPECIFICATIONS**

Motor		RPM Range											
hp	kW	Drive 1		Drive 2		Drive 3		Drive 4		Drive 5		Drive 6	
		60 Hz	50 Hz	60 Hz	50 Hz	60 Hz	50 Hz	60 Hz	50 Hz	60 Hz	50 Hz	60 Hz	50 Hz
2	1.5	680-940	560-775	---	---	850-1130	700-930	---	---	---	917-1152	---	---
3 Std.	2.2	680-940	---	---	---	850-1130	---	---	740-925	1105-1410	---	---	915-1150
3 Hi Eff	2.2	---	---	680-895	---	---	---	895-1120	---	---	---	1110-1395	---
5	3.7	---	---	---	---	---	---	895-1120	740-925	---	---	1110-1395	915-1150

**TABLE 10
MANUFACTURER'S NUMBERS**

DRIVE NO.	DRIVE COMPONENTS					
	ADJUSTABLE SHEAVE		FIXED SHEAVE		BELT	
	BROWNING NO.	OEM PART NO.	BROWNING NO.	OEM PART NO.	BROWNING NO.	OEM PART NO.
1	1VP40X7/8	79J0301	AK69x1	37L4701	AX46	31K7101
2	1VP44x1-1/8	36C0701	BK85x1	49K4101	BX52	P-8-8094
3	1VP44x7/8	53J9601	AK64x1	12L2501	AX46	31K7101
4	1VP60x1-1/8	41C1301	BK95x1	79J2701	BX56	P-8-10082
5	1VP50x7/8	P-8-2187	AK59x1	31K6801	AX46	31K7101
6	1VP60x1-1/8	41C1301	BK77x1	49K4001	BX53	49K3801

Service

The unit should be inspected once a year by a qualified service technician.

⚠ CAUTION

Danger of sharp metallic edges. Can cause injury. Take care when servicing unit to avoid accidental contact with sharp edges.

A-Lubrication

All motors are lubricated at the factory. No further lubrication is required.

B-Filters

Units are equipped with four 18 X 24 X 2" filters. Filters should be checked and replaced monthly with filters of like kind and size. Take note of air flow direction marking on filter frame when reinstalling filters. See figure 12.

NOTE-Filters must be U.L.C. certified or equivalent for use in Canada.

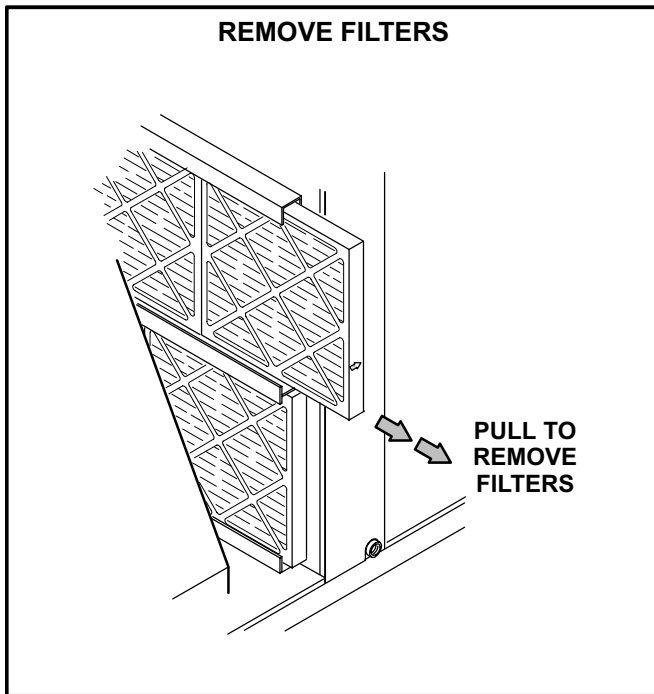

FIGURE 12

C-Indoor Coil

Inspect and clean coil at beginning of each cooling and heating season. Clean using mild detergent or commercial coil cleanser. Flush coil and condensate drain with water taking care not to get insulation, filters and return air ducts wet.

D-Outdoor Coil

Clean outdoor coil annually with detergent or commercial coil cleaner and inspect monthly during the cooling season. Access panels are provided on front and back of outdoor coil section.

E-Supply Air Blower Wheel

Annually inspect supply air blower wheel for accumulated dirt or dust. Turn off power before attempting to remove access panel or to clean blower wheel.