

# installation operation and service instructions

## CHA11-2753/3003 Series Units

PACKAGED COOLING UNITS  
502,640M  
2/91  
Supersedes 502,480M

RETAIN THESE INSTRUCTIONS  
FOR FUTURE REFERENCE

### WARNING

LIQUID LINE AND DISCHARGE LINE SERVICE VALVES HAVE BEEN CLOSED FOR SHIPMENT. DO NOT TURN ON COMPRESSORS WITH VALVES CLOSED. OPEN JUST PRIOR TO UNIT START-UP.

### WARNING

COMPRESSORS ARE EQUIPPED WITH CRANK-CASE HEATERS. POWER TO THE UNIT MUST BE TURNED ON AT ALL TIMES AND AT LEAST 24 HOURS BEFORE THE COMPRESSORS ARE INITIALLY TURNED ON OR IF POWER IS OFF AS MUCH AS 12 HOURS. FAILURE TO DO SO WILL DAMAGE COMPRESSORS.

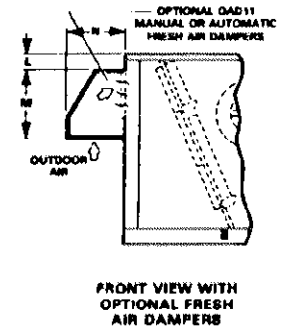
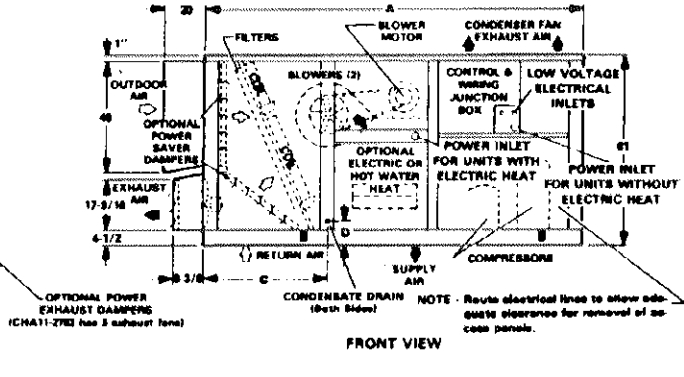
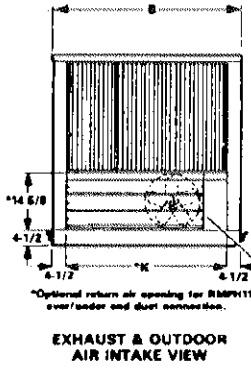
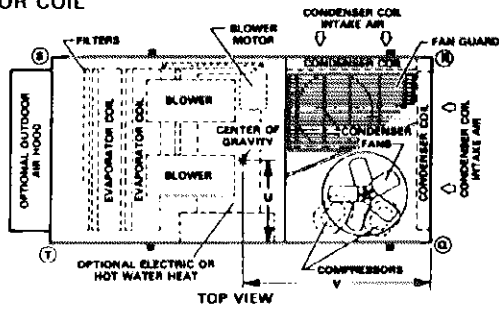
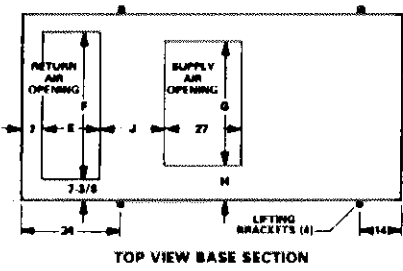
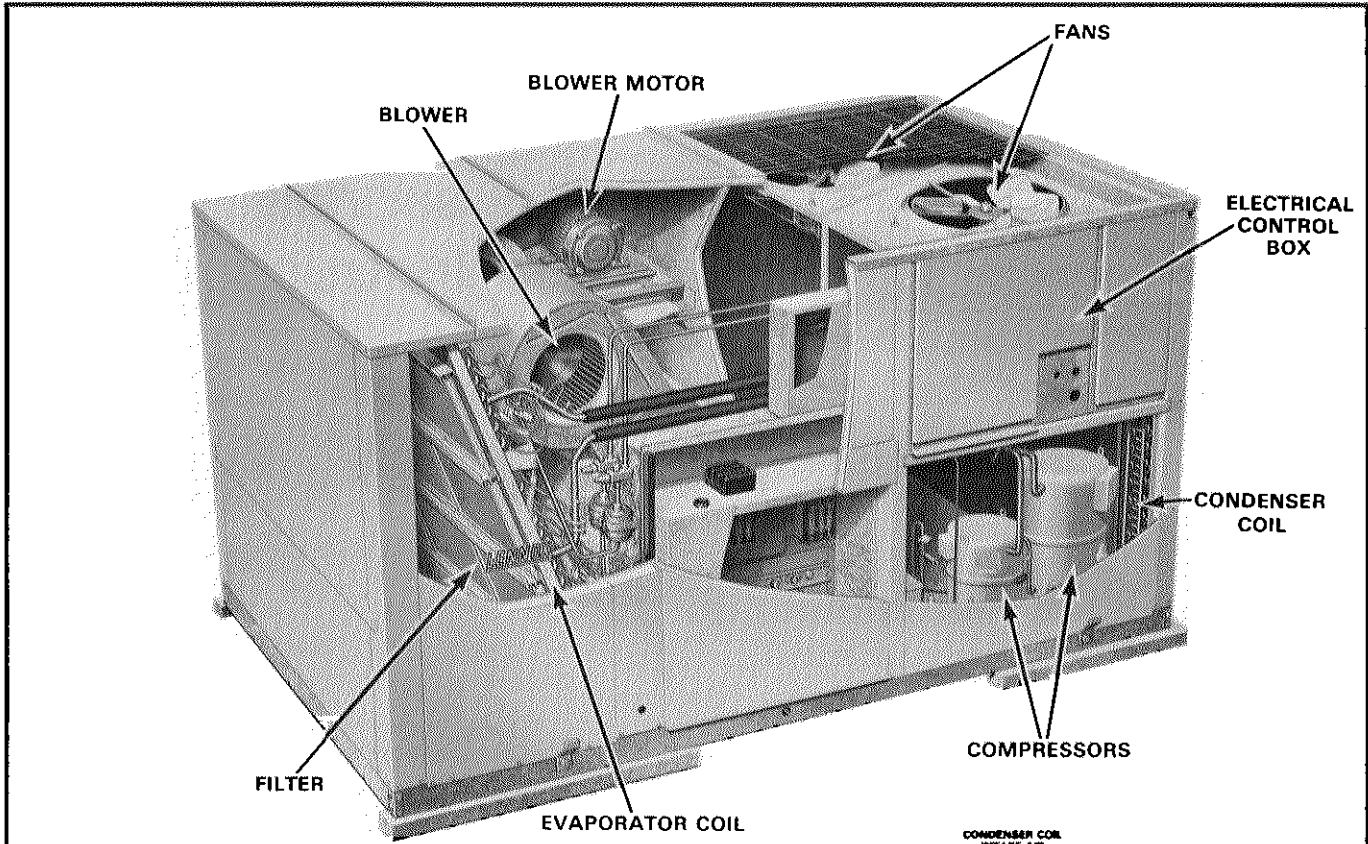

Model No.	A	B	C	D	E	F	G	H	J	K	L	M	N
CHA11-2753	142	78	41	2-3/4	22-1/2	63-5/8	53	12-1/2	20-3/4	68-3/4	7-3/8	33-1/4	24-1/4
CHA11-3003	142	78	41	2-3/4	22-1/2	63-5/8	53	12-1/2	20-3/4	68-3/4	7-3/8	33-1/4	24-1/4

FIGURE 1

**I-SHIPPING AND PACKING LIST**

**Package 1 of 2 contains:**

1-Assembled unit

**Package 2 of 2 (only with factory-installed damper assembly) contains:**

1-Outdoor air intake assembly

**II-SHIPPING DAMAGE**

Check unit for shipping damage. The receiving party should contact the last carrier immediately if any shipping damage is found.

**III-GENERAL**

These instructions are intended only as a general guide and do not supersede local codes in any way. Authorities having jurisdiction should be consulted before installation.

**IV-REQUIREMENTS**

Installation of Lennox air conditioners must conform with standards in National Fire Protection Association (NFPA) "Standard for Installation of Air Conditioning and Ventilating Systems NFPA No. 90A," "Standard for the Installation of Residence Type Warm Air Heating and Air Conditioning Systems NFPA No. 90B," local municipal building codes and manufacturer's installation instructions. Unit is certified for clearance to combustible materials as listed on unit rating plate and in figure 2. Accessibility for service clearance must take precedence over fire protection clearances.

The CHA11 unit is C.G.A. certified as a cooling, electric heating, hot water heating and combination heating (electric or hot water)/cooling unit for outdoor installations only at clearances to combustible materials as listed on the unit nameplate. The CHA11 is certified for installations on non-combustible floors or on combustible floors when installed with Lennox roof mounting frame (RMF11). Units are certified by C.G.A. for 200 through 575 volt, 3 phase, 60 Hz. The installation of C.G.A. certified units is to be in accordance with current C.S.A. Standards C22-1 Canadian Electric Code Part 1, B52-M Mechanical Refrigeration Code and/or local codes.

The power supply to the unit must be on a separate, fused and permanently live electrical circuit. Electrical wiring on all other units must conform with local codes and the current National Electric Code (NEC) ANSI-C1 in the U.S.A. and current Canadian Electrical Code (CEC) C.S.A. 22.1 in Canada. Refer to figure 2 for recommended service clearances. Allow five feet (1524 mm) clearance on top of unit.

**V-RIGGING AND HOISTING**

- 1- Lifting brackets are provided on the unit.
- 2- Rig unit with four lines as shown in figure 3.
- 3- Weight: CHA11-2753 – 2900 lbs. (1314 kg)  
CHA11-3003 – 2900 lbs. (1317 kg)

**CAUTION-Consult mechanical or structural engineer before rolling unit across roof deck.**

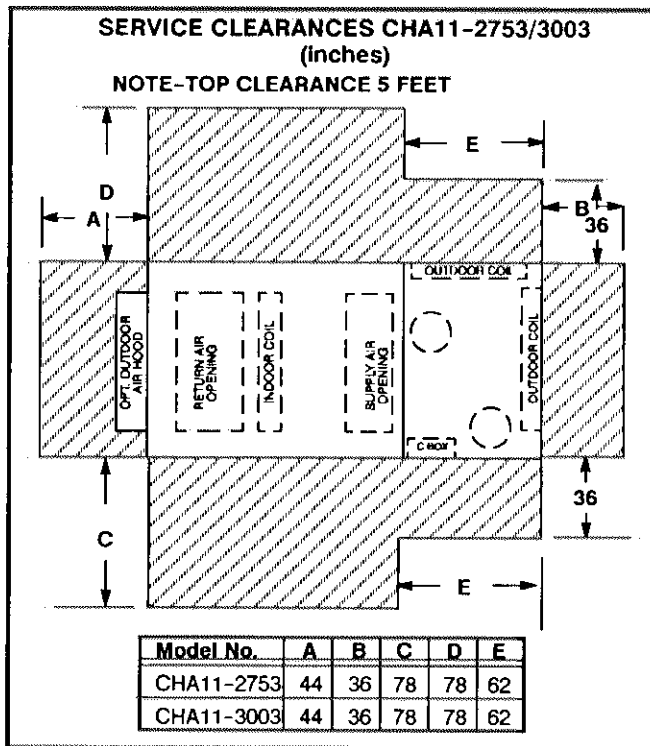

**FIGURE 2**

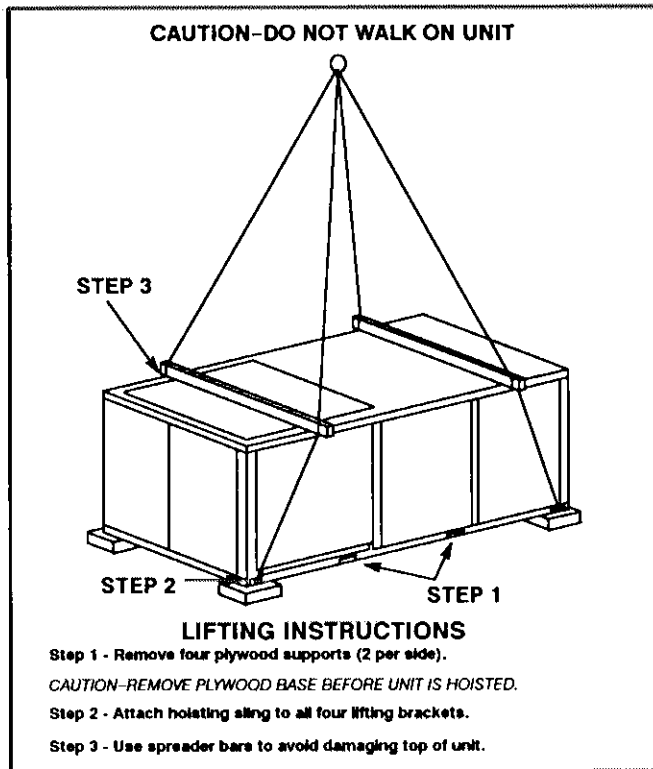

**FIGURE 3**

## VI-UNIT SUPPORT

### A- Roof Mounting with Lennox RMF11 Roof Mounting Frame

*Note-Supply and return air plenums must be installed before setting unit.*

- 1- The RMF11 roof mounting frame must be installed, flashed and sealed and plenums must be in place prior to setting unit. Refer to the instructions provided with the frame.
- 2- Lower unit onto mounting frame. Insulation on base of unit seals against the top of mounting frame.
- 3- Remove rigging cables.

### B- Roof Mounting with Installer's Frame

*NOTE-When using installer's frame, do not flash up above the drain holes in base of unit.*

Many types of roof frames or supports can be used to mount the CHA11 unit, depending upon the roof structure. Items to keep in mind when using an installer's frame or supports are:

- 1- The CHA11 base is fully enclosed and insulated, so an enclosed frame is not required.
- 2- The frames or supports must be square and level to 1/16" per linear foot in any direction.

- 3- Frame or supports must be high enough to prevent any form of moisture from entering unit, Recommended frame height is 14".
- 4- Either wood or metal framing supports are acceptable for mounting.
- 5- Position supports so they will not interfere with the discharge and return air openings.

## VII-DUCT CONNECTION

- 1- When RMF11 is used, the duct can be attached to the roof mounting frame. The duct does not have to be attached to the unit. Refer to RMF11 installation instructions.
- 2- Secure duct to the unit flanges with screws if RMF11 is not used. Unit supply and return air opening sizes are shown in figure 1.

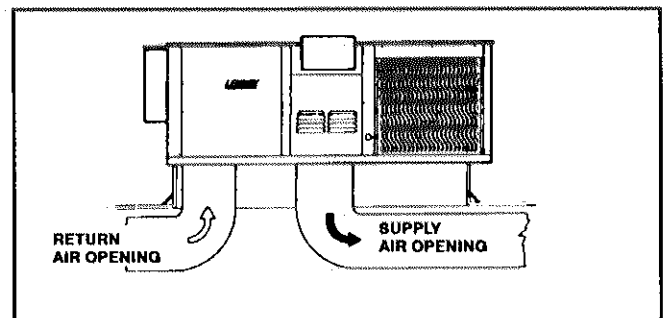

**FIGURE 4**

**CAUTION-Do not drill or punch holes in base of unit. Leaking in roof may occur if unit is punctured.**

- 3- All exterior portions of duct must be insulated.
- 4- Duct must be sealed weathertight around opening in roof or building wall.

## VIII-CONDENSATE DRAINS

Condensate drain access is provided from either side of unit. Refer to figure 1 for location of condensate drain. The following practices are recommended to ensure condensate removal. Before installation, check local codes concerning condensate removal. Refer to figure 5 for typical condensate piping.

- 1- Drain piping should not be smaller than drain connection at coil.
- 2- A trap in the drain is required.
- 3- The trap must be deep enough to offset the difference in static pressure between drain pan and atmosphere. Generally 2 inches (51 mm) minimum is satisfactory for medium static applications.
- 4- Horizontal runs must be pitched 1 inch (25 mm) per 10 feet (3048 mm) of drain line to offset line friction.

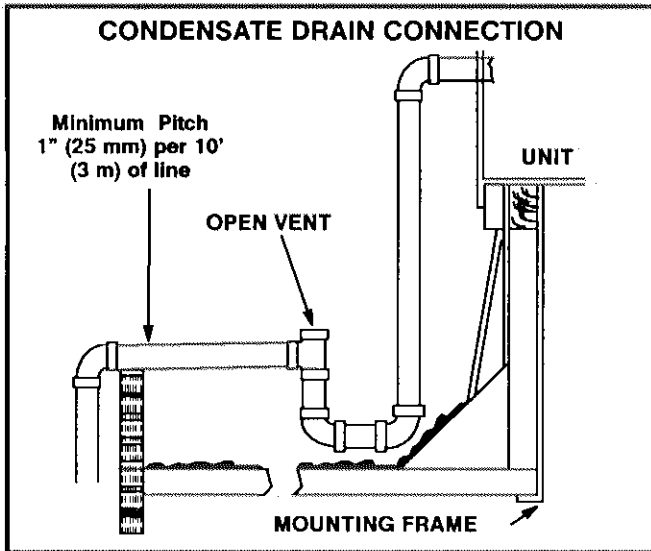
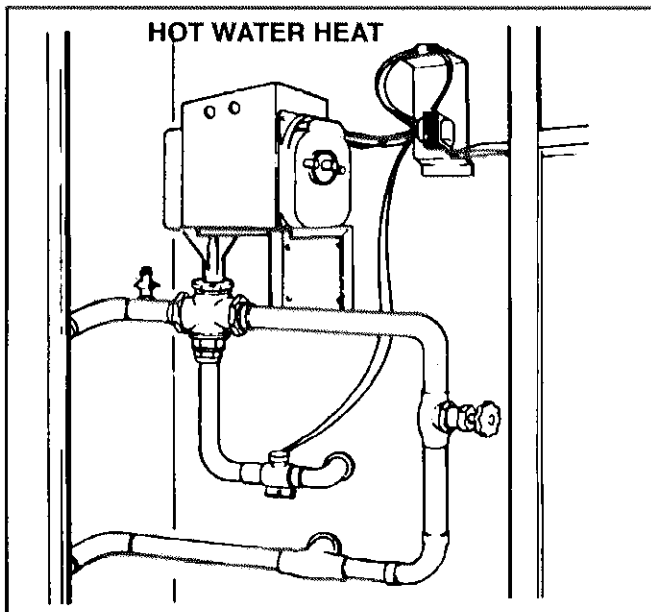

**FIGURE 5**

- 5- An open vent in drain line will sometimes be required due to line length, friction and static pressure.
- 6- Drains should be constructed in a manner to facilitate future cleaning.
- 7- On applications where drain line is not required, install a 90° elbow to direct condensate downward.

**IX-HOT WATER HEAT COIL PIPING**

Field piping consists of 1-5/8" sweat supply and return line connections to the coil. See figure 6.



**FIGURE 6**

**X-OUTDOOR INTAKE HOOD**

An outdoor air intake hood package is furnished with units having a factory-installed economizer. The hood is also packaged with the field-installed REMD11M option. Slip top flange of air intake hood under lip of unit cap. Hold hood in place and drill mounting holes in unit using existing holes in hood as a guide. Use #20 drill bit. Secure hood to unit using screws provided. See figure 7.

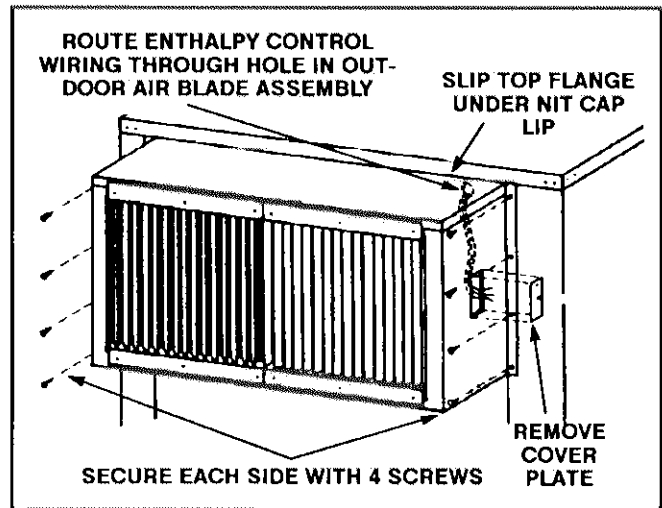

**FIGURE 7**

**XI-BLOWER BELTS**

Use the following procedure to install blower belts.

- 1- Clean oil and grease from the grooves. Also remove any rust or burrs from the sheave grooves.
- 2- Shorten the center distance of the drive until the belts can be put on the sheaves without forcing.
- 3- Make sure that the sheaves are correctly aligned, that the shafts are parallel, that there is clearance for the drive to run and that the bearings are lubricated.

*NOTE-Ideal tension is the lowest tension at which the belt will not slip under peak load conditions. Overtensioning shortens belt and bearing life.*

**XII-ELECTRICAL CONNECTIONS – POWER SUPPLY**

The power supply entry is located at the front of the unit. Power supply wiring enters through the large conduit fitting shown in figure 1.

**CAUTION-Do not apply power or close disconnect switch until installation is complete. Refer to start-up directions.**

**NOTE TO ELECTRICAL CONTRACTOR**

*To allow for serviceability, use discretion in mounting disconnect on unit. On all installations, provide clearance for removing access panels and for servicing unit.*

### **A- Power Wiring Units with Cooling Only, Cooling with Factory-Installed Hot Water Heat or Factory-Installed Hot Water Heat Only**

- 1- Refer to unit rating plate for minimum circuit ampacity and maximum fuse size.
- 2- Route supply wiring to conduit connection in high voltage junction box.
- 3- Refer to field wiring diagram on unit control box cover and in figure 8 for field wiring connections.

### **B- Power Wiring for Units with Cooling and Factory-Installed Electric Heat or Factory-Installed Electric Heat Only**

- 1- Refer to unit rating plate for minimum circuit ampacity and maximum fuse size.
- 2- Route supply wiring to conduit connection in electric heat mullion.
- 3- Refer to unit field wiring diagram on unit and in figure 8. The incoming power connects to power terminal strip in heat section. Subfusing protects the unit and provides a separate circuit from the electric elements.

### **C-Power Wiring with Field-Installed Electric Heat\***

The heater installed plate on the unit access panel lists the minimum circuit ampacity and maximum fuse size for the unit combined with the various heaters.

Install the electric heat components and wire according to ECH11 installation instructions.

*\*Does not apply to C.G.A. certified units.*

## **XIII-ELECTRICAL CONNECTION – CONTROLS AND OPTIONS**

Control wiring for CHA11 units are made at the low voltage terminal block in the low voltage make-up box at the front of the unit. Refer to field wiring diagram on unit and in figure 8.

### **A-Thermostat Location and Rough-In**

The thermostat mounts on any non-conductive, vertical surface. Locate thermostat approximately 5 feet (1524mm) above the floor in an area with good air circulation at average temperature. Avoid locating the thermostat where it might be affected by:

- \*Drafts or dead spots behind doors and in corners.
- \*Hot or cold air from ducts.
- \*Radiant heat from sun or appliances.
- \*Concealed pipes and chimneys.

### **B-Control Wiring**

- 1- Route thermostat cable or wires from subbase through knockout provided in unit. Plastic bushing is shipped loose in field make-up compartment and must be installed in 24 volt control wiring knockout if conduit is not used. See field wiring diagram on unit and in figure 8. For thermostat wire runs up to 50 ft. (15 m), use 18-gauge wire; and for 50 to 90 ft (19 to 27 m) runs, use 16-gauge wire.
- 2- Install thermostat assembly in accordance with instructions provided with thermostat.

*IMPORTANT-Terminal connections at wall plate or subbase must be made securely. Loose control wire connections may allow unit to operate; however, improper response to room demand may result.*

### **C-Optional Remote Status Panel**

Route nine wires from status panel location to the unit low voltage 24 VAC inlet as shown in figure 8 and field wiring diagram on unit. Field wiring diagram also shows proper connection to the status panel terminal block.

### **D- Optional Field- or Factory-Installed Economizer (REMD11M)**

The REMD11M economizer is available as either a factory- or field-installed option. In cases where the economizer has been factory-installed, refer to the REMD11M instructions shipped in the unit control box for field installation of outdoor air intake hood. Field wiring of the enthalpy sensor is also covered in the economizer instructions and in the field wiring diagram on the unit and in figure 8.

For field installation of the REMD11M, see instructions packaged with the economizer. Refer to economizer instructions and field wiring diagram on unit and in figure 8.

### **E- Optional Field- or Factory-Installed Power Exhaust Dampers (PED11)**

When power exhaust dampers are field-installed, follow installation instructions shipped along with PED11. Refer to wiring section in instructions as well as field wiring diagram on unit and in figure 8.

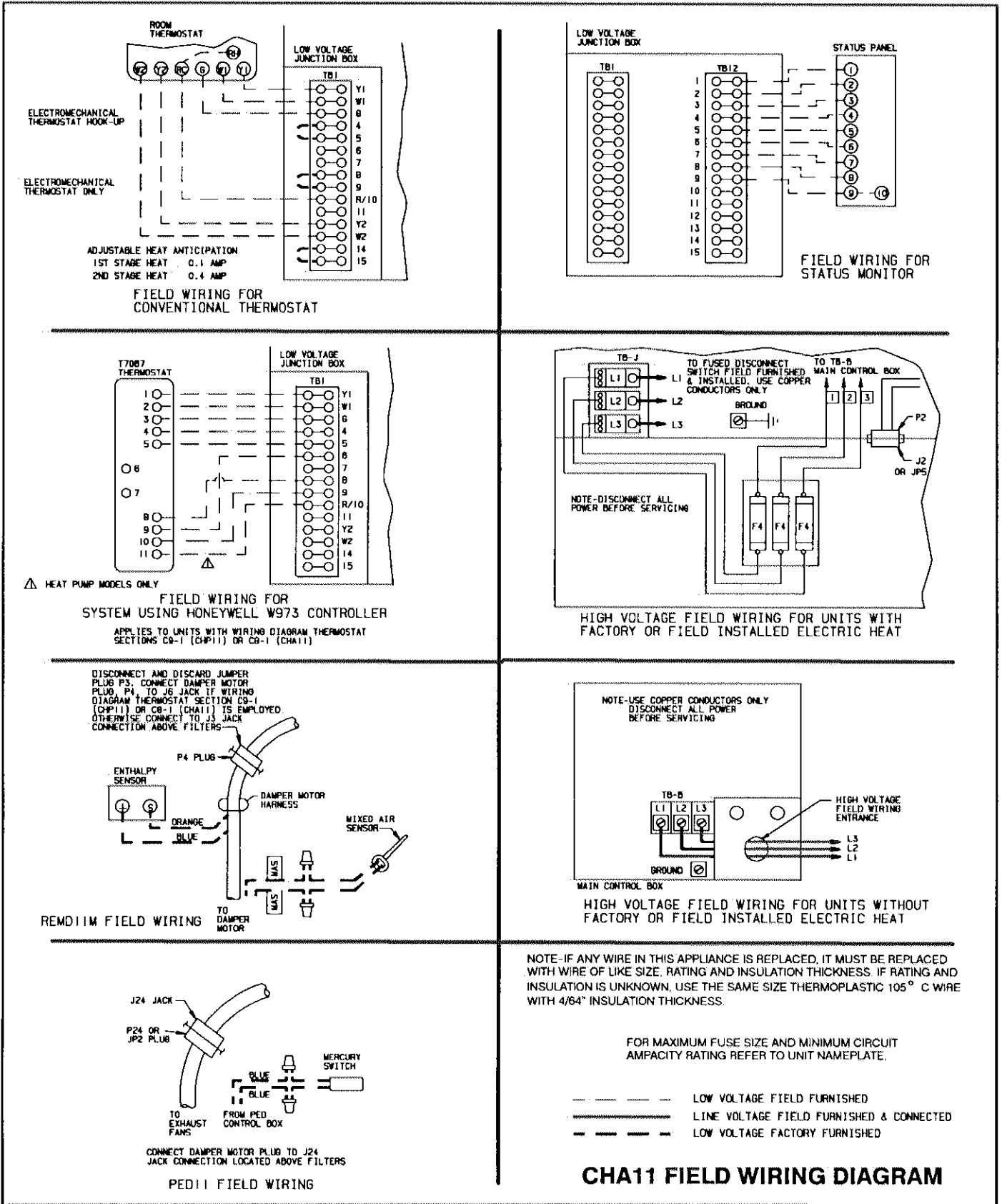
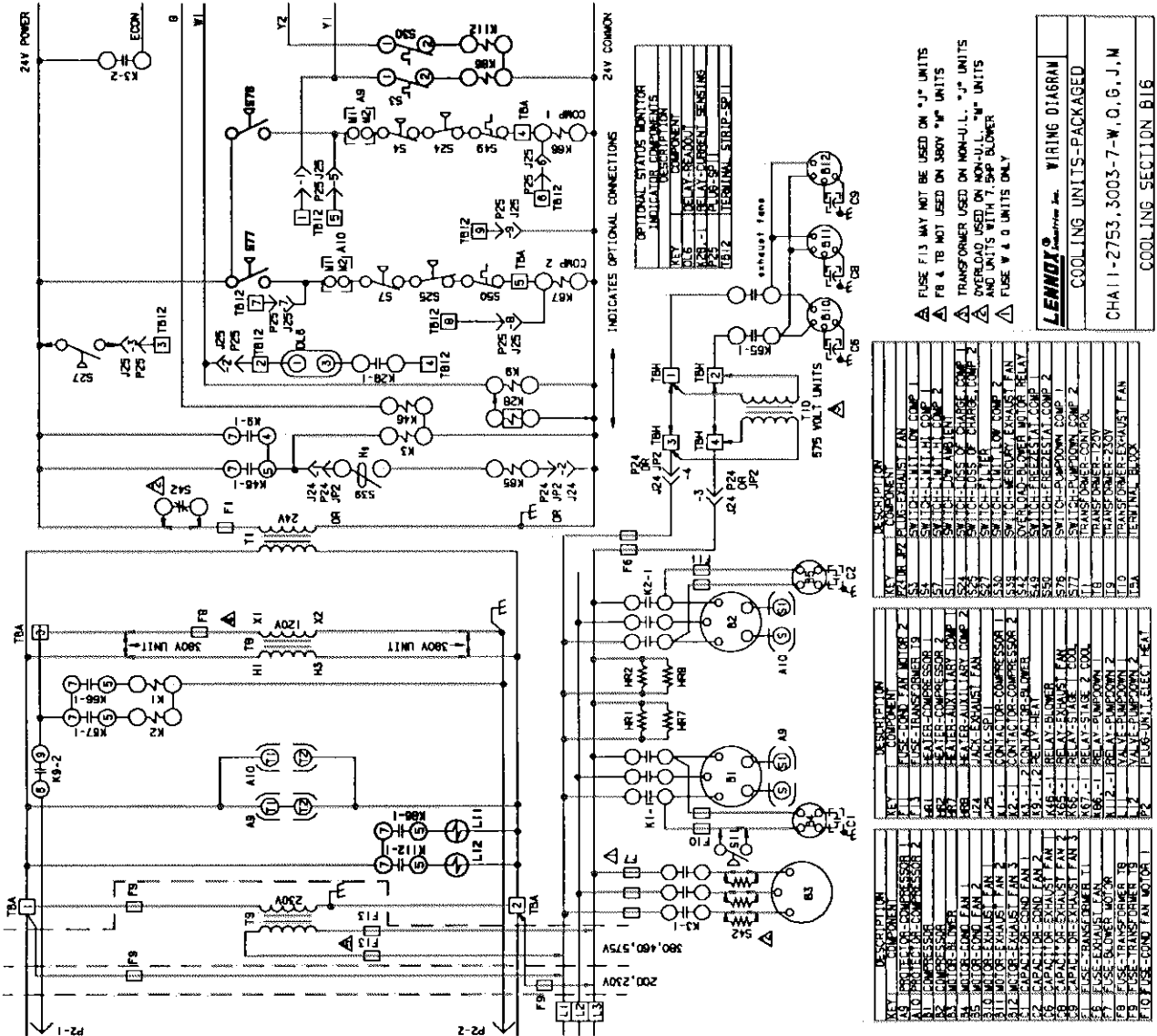

FIGURE 8



TYPICAL CHA11-2753/3003 UNIT WIRING DIAGRAM

FIGURE 9



# START-UP — OPERATION — ADJUSTMENTS

## I-COOLING START-UP

**WARNING**—Liquid line and discharge service valves have been closed for shipment. Do not turn on compressors with valves closed. Open only just prior to start-up.

### A-Energizing Crankcase Heaters

The crankcase heaters must be energized 24 hours before attempting to start compressors. Set thermostat levers so there is no demand to prevent compressors from cycling. Apply power to unit.

### B-Preliminary Checks

- 1- Make sure that unit is installed in accordance with the installation instructions and applicable codes.
- 2- Inspect all electrical wiring, both field and factory installed, for loose connections. Tighten as required.
- 3- Check to ensure that refrigerant lines do not rub against the cabinet or against other refrigerant lines.
- 4- Check voltage at disconnect switch. Voltage must be within range listed on nameplate. If not, consult power company and have voltage condition corrected before starting unit.

### C-Cooling Start-Up

- 1- Set fan switch to **AUTO** or **ON** and move system selection switch to **COOL**. Adjust thermostat to a setting below room temperature to bring on both compressors. Compressors will start and cycle on demand from thermostat.
- 2- Each refrigerant circuit is separately charged with R-22 refrigerant. See unit rating plate for correct amount of charge.
- 3- Refer to Cooling Operation and Adjustment section for proper method to check refrigerant charge.

## II-HEATING START-UP

### To Place Unit Into Operation:

- 1- Move thermostat heat setting above room temperature.
- 2- Optional electric heat elements are energized in one or two stages depending on heater size (20Kw to 90Kw) and unit voltage.

## III-UNIT PROCESSING

### A-Refrigerant Charge and Check

TABLE 1

MODEL NO.	1ST STAGE		2ND STAGE	
	lbs.	kg	lbs.	kg
CHA11-2753	19	8.63	20.5	9.31
CHA11-3003	19	8.63	20.5	9.31

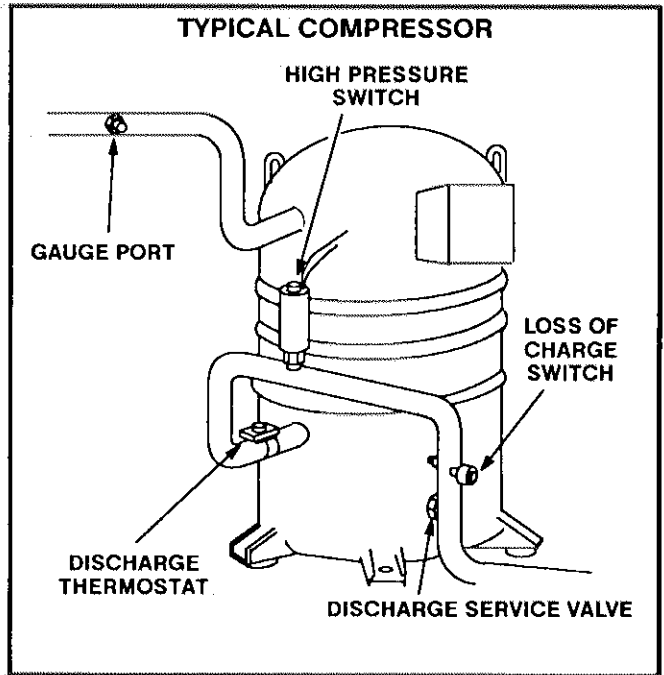

FIGURE 10

Each refrigerant circuit is separately charged with R-22 refrigerant. See table 1 for correct amount of charge. Check the refrigerant charge as follows:

- 1- Attach gauge manifold. Refer to figure 10 for service valve identification.
- 2- Check each circuit separately. Set room thermostat as low as possible to provide a full cooling demand.
- 3- Allow system to run for a few minutes to stabilize system.
- 4- Using a thermometer, find condenser entering air temperature. Read suction and discharge pressures on gauge manifold.
- 5- Refer to normal operating pressures curve affixed to unit or see correct pressure curve from Lennox Unit Information Service Manual. Find suction pressure in the left hand column. Follow across the curve to correct outdoor coil entering air temperature. Mark this

point, then read discharge pressure directly below. If discharge reading is within 3 psig (0.21 kg/cm<sup>3</sup>) of gauge manifold reading, system is properly charged.

### Charging

If the system is completely void of refrigerant, the recommended and most accurate method of charging is to weigh the refrigerant into the unit according to the amount shown on unit rating plate and in table 1. If weighing facilities are not available or if unit is just low on charge use the following procedure:

- 1- Attach gauge manifold and connect an upright drum of R-22 to the center port of gauge manifold.
- 2- Open drum valve and charge a quantity of refrigerant gas into the system through the suction port. Close refrigerant drum valve and allow unit to run to stabilize operating pressures.
- 3- Check refrigerant charge according to section A. Continue to charge and check charge until proper charge is obtained.

## IV-BLOWER OPERATION AND ADJUSTMENTS

### A-Blower Operation

Blower operation is manually set at the thermostat sub-base fan switch. With fan switch in **ON** position, blowers will operate continuously. With fan switch in **AUTO** position, blowers will cycle with demand. Blowers and entire unit will be off when system switch is in **OFF** position. Table 2 lists drive kit options.

*NOTE-Units are equipped with a pulley which provides higher RPM range. An extra pulley is shipped in blower compartment if lower blower speeds are required.*

**TABLE 2**

MODEL NO.	NOMINAL MOTOR HP	MAXIMUM USABLE HP	RMP RANGE OF ALL AVAILABLE DRIVE SETUPS @1720 RPM MOTOR SPEED
CHA11-2753	5	5.75	600 - 760
	5		*790 - 995
	7.5	8.625	900 - 1070
CHA11-3003	7.5	8.625	940 - 1090

*\*Units are shipped with higher RPM range pulley in place.*

### B-Determining Unit CFM

- 1- The following measurements must be made with a dry indoor coil. Run the blower without a cooling demand. The air filters must be in place while taking measurements.
- 2- Measure static pressure external to unit (from supply to return).
- 3- Measure the indoor blower motor RPM
- 4- Refer to tables 3 through 5. Use the static pressure and RPM readings to determine Unit CFM.
- 5- The CFM can be adjusted at the motor pulley. Loosen the allen screw. Turn adjustable sheave clockwise to increase unit CFM. Turn counterclockwise to decrease unit CFM. See figure 11.

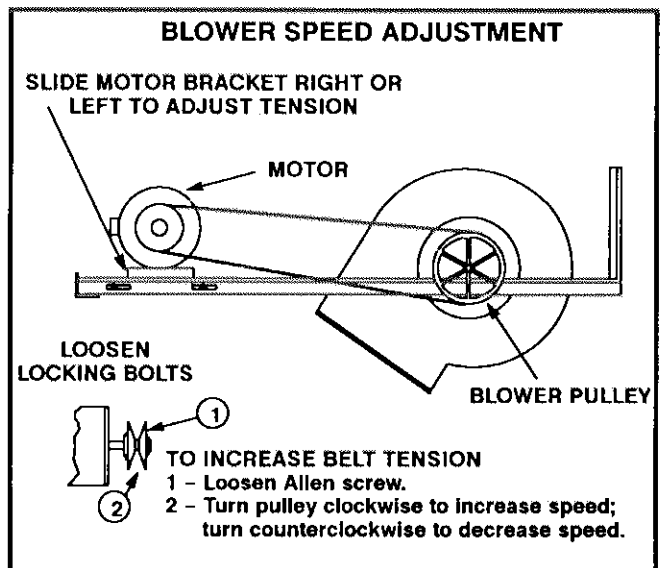

**FIGURE 11**

### C-Blower Belt Adjustment

Maximum life and wear can be obtained from belts only if proper pulley alignment and belt tension are maintained. Initially, tension new belt(s) a after 24 - 48 hour period of operation. Belt(s) will stretch and seat in grooves during this period. To adjust belt tension, loosen four locking bolts. Turn adjusting screws and slide motor up or down. See figure 11.

TABLE 3  
CHA11-2753 (WITHOUT ELECTRIC HEAT) BLOWER PERFORMANCE

Air Volume (CFM)	STATIC PRESSURE EXTERNAL TO UNIT — (INCHES WATER GAUGE)																				
	0.10	0.20	0.30	0.40	0.50	0.60	0.70	0.80	0.90	1.00	RPM	BHP	RPM	BHP	RPM	BHP	RPM	BHP	RPM	BHP	RPM
7000	—	—	—	645	2.45	680	2.80	720	3.05	760	3.35	800	3.65	830	3.90	875	4.25				
7500	—	—	—	670	2.85	710	3.20	745	3.45	780	3.75	815	3.95	850	4.20	885	4.55				
8000	—	—	660	2.95	700	3.30	735	3.60	770	3.85	800	4.10	830	4.35	870	4.65	900	4.95			
8500	—	650	3.05	720	3.70	760	4.00	790	4.25	820	4.45	850	4.70	880	5.00	920	5.40				
9000	630	3.20	680	3.55	715	3.80	750	4.20	785	4.45	815	4.65	840	4.90	875	5.20	910	5.60	935	5.85	
9500	665	3.65	705	4.05	740	4.40	770	4.60	800	4.90	830	5.20	865	5.45	900	5.80	930	6.10	960	6.50	
10000	700	4.20	735	4.55	770	4.95	795	5.15	825	5.45	855	5.70	895	6.05	925	6.35	950	6.65	975	6.95	

TABLE 4  
CHA11-2753 (WITH HOT WATER HEAT) BLOWER PERFORMANCE

Air Volume (CFM)	STATIC PRESSURE EXTERNAL TO UNIT — (INCHES WATER GAUGE)																				
	0.10	0.20	0.30	0.40	0.50	0.60	0.70	0.80	0.90	1.00	RPM	BHP	RPM	BHP	RPM	BHP	RPM	BHP	RPM	BHP	RPM
7000	—	660	2.20	710	2.55	745	2.80	780	3.15	825	3.45	865	3.65	900	3.90	925	4.10	950	4.30		
7500	650	2.30	700	2.65	740	2.95	780	3.35	820	3.55	855	3.85	895	4.10	920	4.35	945	4.55	970	4.80	
8000	695	2.80	730	3.15	775	3.45	815	3.80	850	4.05	885	4.30	915	4.50	945	4.80	970	5.10	990	5.30	
8500	740	3.40	770	3.70	815	4.05	850	4.30	885	4.55	920	4.85	945	5.10	970	5.35	985	5.55	1020	5.90	
9000	770	3.85	815	4.30	850	4.55	885	4.85	915	5.10	945	5.40	970	5.70	990	5.90	1020	6.25	1045	6.60	
9500	810	4.55	855	4.95	890	5.20	920	5.50	945	5.75	970	6.05	995	6.35	1020	6.60	1045	6.95	1075	7.40	
10000	855	5.20	895	5.55	925	5.90	975	6.20	975	6.50	1000	7.10	1025	7.10	1050	7.40	1075	7.75	1100	8.15	

TABLE 5  
CHA11-3003 BLOWER PERFORMANCE

Air Volume (CFM)	STATIC PRESSURE EXTERNAL TO UNIT — (INCHES WATER GAUGE)																													
	0	.10	.20	.30	.40	.50	.60	.70	.80	.90	1.00	1.10	1.20	1.30	1.40	RPM	BHP	RPM	BHP	RPM	BHP	RPM	BHP	RPM	BHP	RPM	BHP	RPM	BHP	
7600	690	2.40	715	2.65	760	3.00	800	3.25	835	3.55	865	3.90	905	4.30	935	4.55	965	5.10	995	5.35	1025	5.70	1050	6.10	1070	6.20	1085	6.45	1110	6.70
7800	700	2.60	730	2.85	775	3.15	815	3.45	850	3.75	890	4.20	915	4.45	945	4.85	980	5.30	1010	5.65	1040	6.05	1060	6.30	1075	6.45	1100	6.75	1130	7.00
8000	715	2.80	750	3.05	790	3.30	830	3.65	865	4.05	900	4.40	930	4.75	965	5.15	995	5.55	1025	5.95	1050	6.30	1070	6.40	1085	6.70	1110	7.05	1140	7.55
8200	735	3.00	770	3.25	810	3.60	845	3.90	880	4.25	915	4.65	940	5.00	980	5.45	1010	5.85	1035	6.20	1060	6.50	1075	6.70	1095	7.00	1125	7.40	1150	7.80
8400	750	3.20	785	3.40	825	3.75	860	4.20	895	4.55	925	4.85	960	5.35	1000	5.85	1020	6.10	1050	6.50	1070	6.75	1085	6.95	1110	7.25	1135	7.75	1165	8.25
8600	770	3.40	805	3.65	840	4.00	875	4.40	910	4.80	940	5.20	975	5.65	1015	6.10	1035	6.35	1060	6.70	1080	7.00	1095	7.25	1120	7.55	1150	8.10	1180	8.50
8800	785	3.55	820	3.90	855	4.25	890	4.65	925	5.10	955	5.50	995	5.95	1025	6.35	1050	6.70	1070	7.00	1085	7.25	1110	7.50	1135	8.00	1165	8.50	—	—
9000	805	3.85	840	4.20	870	4.55	905	5.00	935	5.35	970	5.75	1010	6.25	1040	6.65	1060	6.90	1075	7.25	1095	7.50	1125	7.95	1145	8.30	—	—	—	—
9200	825	4.15	855	4.50	890	4.90	920	5.25	955	5.70	990	6.05	1020	6.45	1050	6.95	1070	7.25	1085	7.50	1110	7.85	1135	8.35	—	—	—	—	—	—
9400	840	4.40	875	4.75	905	5.15	940	5.70	970	6.00	1005	6.45	1040	6.90	1060	7.20	1080	7.60	1100	7.90	1125	8.30	—	—	—	—	—	—	—	—
9600	855	4.70	890	5.05	925	5.50	950	5.90	985	6.30	1020	6.75	1045	7.10	1070	7.50	1085	7.80	1115	8.15	1135	8.65	—	—	—	—	—	—	—	—
9800	875	5.00	910	5.45	935	5.80	965	6.15	1005	6.70	1035	7.10	1060	7.50	1080	7.85	1100	8.20	1130	8.65	—	—	—	—	—	—	—	—	—	—
10,000	895	5.35	925	5.75	955	6.20	985	6.55	1020	7.00	1050	7.45	1070	7.80	1090	8.20	1115	8.60	—	—	—	—	—	—	—	—	—	—	—	—

NOTE—Data is from units equipped with a 1" filter.  
NOTE—Data does not include the effects of economizer or electric heat

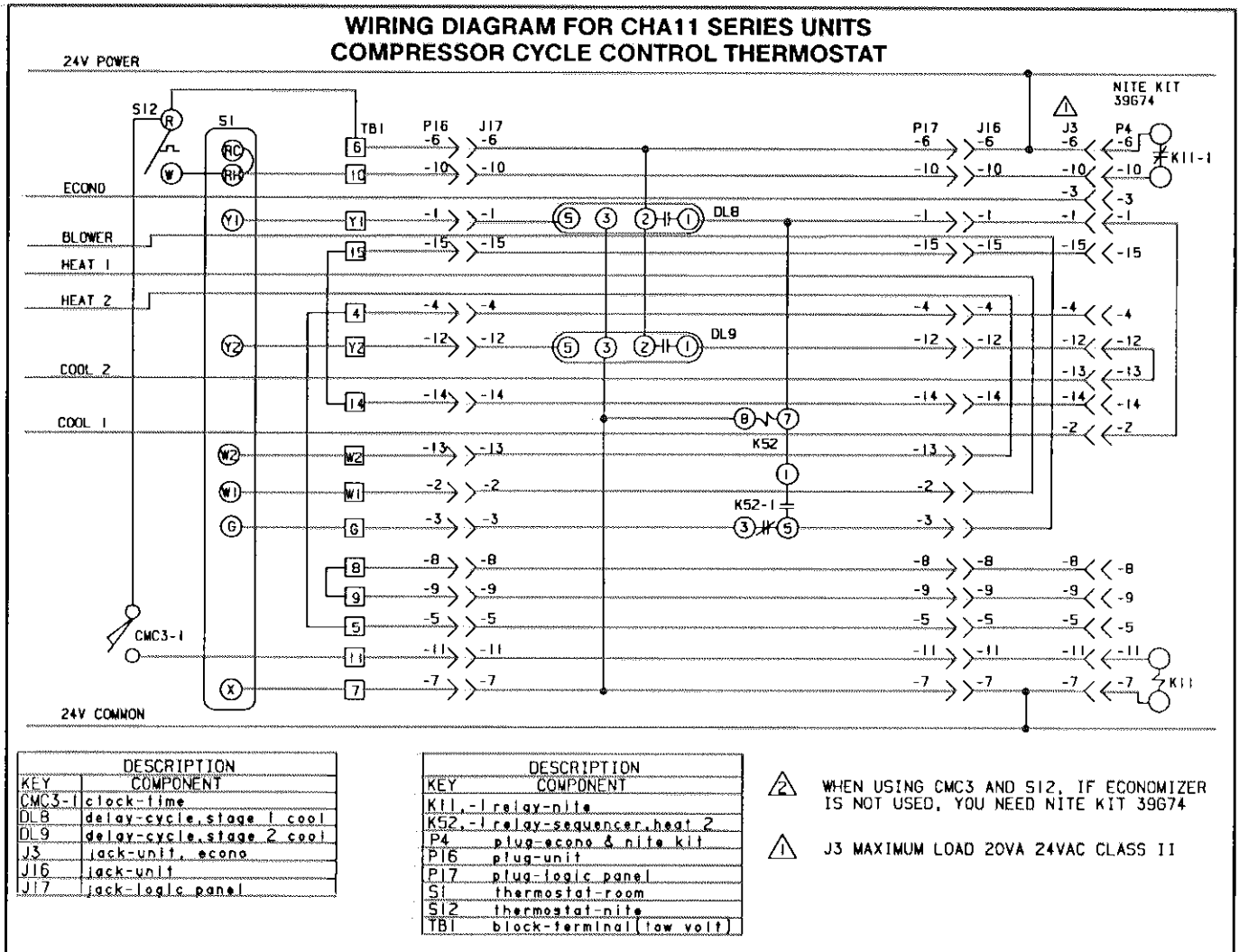

**FIGURE 12**

## V-COMPRESSOR CONTROLS

### A-High Pressure Switch

Each compressor circuit is protected by a manually reset high pressure switch.

### B-Loss of Charge Switch

Each compressor circuit is protected by a loss of charge switch. Switch cuts out at 25 psig (172.5 kPa) and automatically resets at 55 psig (379.5 kPa).

### C-Crankcase Heaters

Each compressor has two compressor oil heaters which must be on at all times.

### D- Compressor Low Limit Switch (Compressor Monitor)

Located in the low voltage junction box, the compressor low limit (compressor monitor) switch (S3 and S30) is factory set at 55° F (12.8° C).

The compressor will not provide mechanical cooling below the control setting which is variable from 20° F (-6.7°C) to 80°F (26.7°C).

### E-Cycle Control

CHA11-2753/3003-5 units are equipped with a cycle control to prevent unit short cycling. The control (LB-62838BA) is located just above the T8 transformer in the main control box. This control is used with electro-mechanical thermostats. It can be removed in applications using energy management controls. See wiring diagram in figure 12.

### F-Freezestats (S49, S50)

Each indoor coil has a freezestat mounted on the lowest outlet tube to prevent icing. The control lockouts compressor at 29° F (-1.6°C) and resets at 58° F (14.4°C).

## VI-RECYCLE PUMP-DOWN CONTROLS

A pump-down control is provided on each cooling stage which will automatically cycle the compressor at preset suction pressures when there is no cooling demand or if outdoor ambient temperature is below the compressor monitor (S3 or S30) settings.

The purpose of the control is to keep liquid refrigerant out of the compressor during long "OFF" cooling periods.

### A-Components

- 1- *Liquid Line Solenoid Valves (L11, L12)* – normally closed devices located near the expansion valves in the blower section.
- 2- *Pump-Down Relays (K86, K112)* – have normally open contacts and are located in the main control box just above TBA on the low voltage control box. Pump-down relays are wired in the thermostat circuit.
- 3- *Low Pressure Switches (S76, S77)* – switches open on a suction pressure drop of  $15 \pm 4$  psig to de-energize compressors. When suction pressure equalizes to  $35 \pm 4$  psig, low pressure switches close allowing power to the cooling legs. S76 and S77 are located on the compressor suction line in the compressor section of the unit.

### B-Operation

- 1- *Routine operation*  
K86 is energized on a Y1 cooling demand when S3 is closed. K86-1 contacts close energizing L11 liquid line solenoid valve open, allowing standard refrigerant flow.
- 2- *Solenoid valve closes*  
When Y1 cooling demand terminates or S3 opens, K86 is de-energized opening K86-1 contacts. The liquid line solenoid valve is de-energized to closed position preventing flow of refrigerant into the evaporator.
- 3- *Pump-down cycle operation*  
After a cooling demand terminates, the compressor continues to run until the suction pressure is "pumped-down" to  $15 \pm 4$  psig. S76 opens, de-energizing the compressor.  
The compressor remains de-energized until the suction pressure equalizes and the low pressure switch resets (closes) at  $35 \pm 4$  psig.  
The pump-down cycle will repeat until there is a cooling demand and S3 closes.
- 4- *Typical cycle rates*  
Initial pump-down (on) 8-15 seconds  
Repeat pump-down (on) 2 seconds  
Reset times (equalizing) 2 to 6 hours

## VII-ELECTRIC HEAT OPTION

Electric heat elements are energized in one to six stages, depending on heater size (20 to 90 Kw) and unit voltages. Elements are staged automatically by time delays.

## VIII-HOT WATER HEAT OPTION

- 1- The motorized three-way valve opens on heating demand to direct hot water through the heating coil or bypass circuit.
- 2- The hot water coil is equipped with an air bleed valve and a drain valve.
- 3- A freeze protection thermostat monitors coil manifold temperature to open valve and close economizer ((if used) to prevent coil freezing during a no-demand period.
- 4- A manual balancing valve is provided for balancing the pressure drop from the by-pass line to the coil.
- 5- Maximum supply water temperature is 200° F.

## IX-REMD11M ECONOMIZER OPTION (FIGURE 14)

- 1- Dampers are factory set and should not require adjustment. If adjustment is necessary, use the following as a guide after unit checkout has been completed.  
Fully open outdoor air dampers by setting the thermostat for a cooling demand and the enthalpy control to **A**. Return air dampers should fully close. Check each damper blade and adjust individually is necessary.  
Shut off power to unit. Damper actuator will spring return outside air dampers to the fully closed position. Check each damper and adjust individually if necessary.
- 2- The enthalpy sensor is located in the outdoor air inlet of unit. This control prevents excessively moist outdoor air from entering the system by sensing the total heat content of the outdoor air. The LED on the enthalpy control is lit during "low" enthalpy conditions. The recommended setpoint is **A** shown in figure 13. If the economizer is allowing air which is too moist or too humid to enter the system, the control may be changed to a lower setpoint. See figure 13.
- 3- Adjust minimum positioner (located on the damper motor) with outside dampers at minimum position. Turn enthalpy control to **D** setting or use simulator to drive dampers to minimum position.  
Rotate screw clockwise to open dampers or counter-clockwise to close dampers. See table 6 for percentage of fresh air versus dimensional opening of blade at system static pressure.

**IMPORTANT**—After adjustment is complete, return enthalpy control to its normal setting.

**TABLE 6**

Damper Blade Angle	FRESH AIR PERCENTAGE (%)		
	Return Air Duct Static Pressure		
	0" (0 mm)	.25" (6 mm)	.5" (13 mm)
	REMD11M	REMD11M	REMD11M
5°	13%	20%	30%
10°	26%	34%	46%
15°	37%	46%	57%
20°	48%	57%	66%
25°	58%	66%	74%
30°	69%	75%	81%
35°	79%	84%	88%
40°	90%	92%	94%

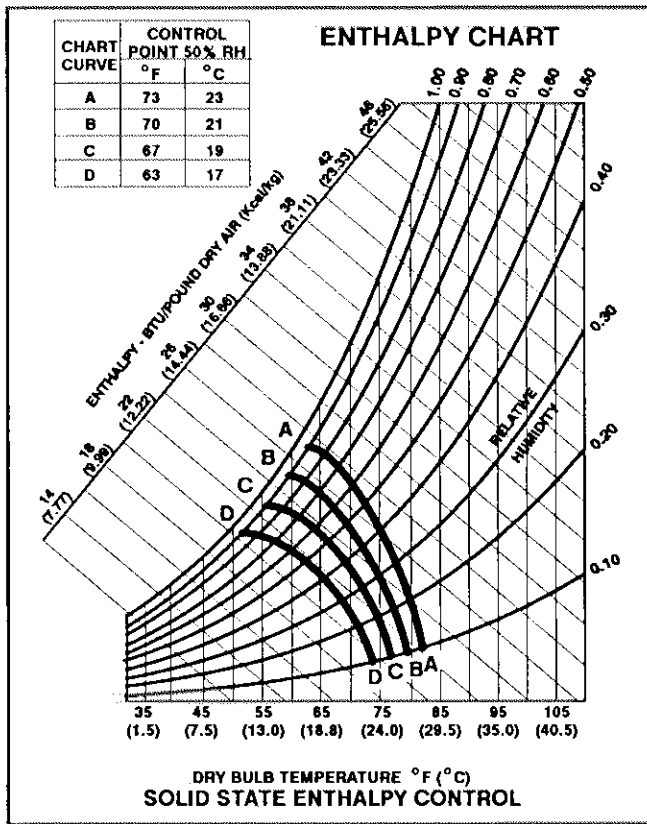

**FIGURE 13**

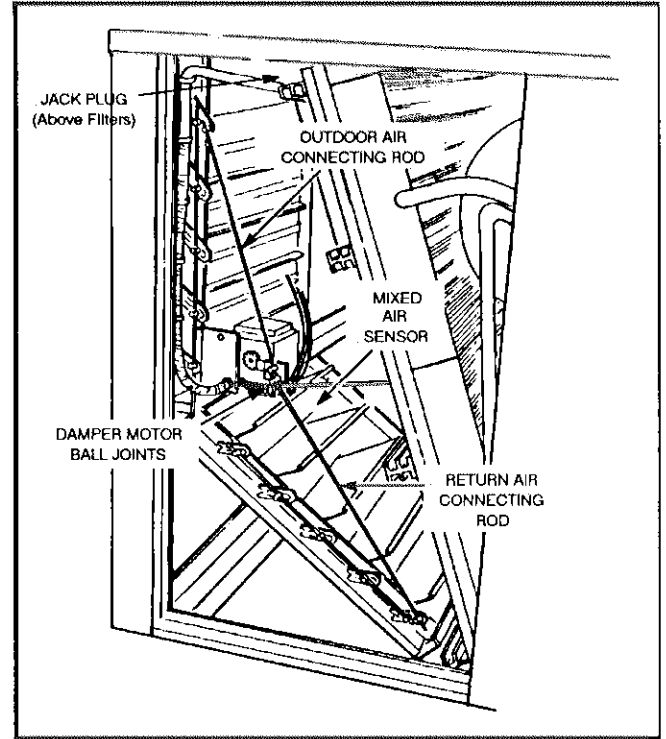

**FIGURE 14**

**X-OPTIONAL REMOTE STATUS PANEL**

The status panel allows remote monitoring of system operation.

- 1- The **CODE MODE** LED is green when lit. It indicates economizer operation. Otherwise the LED will indicate DX cooling operation.
- 2- The **HEAT MODE** LED is green during heating operation.
- 3- The **COMPRESSOR 1** and **COMPRESSOR 2** LED's are green when the respective compressors are running. Either light will turn red if a compressor safety switch opens during a compressor demand.
- 4- The **NO HEAT** LED will light red when the filter pressure switch contacts close, indicating a dirty filter.

## **SERVICE**

**CAUTION**–Turn off electrical power to the unit before performing any maintenance or service operations on the unit.

Take care when servicing unit to avoid accidental contact with any sharp metallic edges which may cause injury.

### **A–Lubrication**

*NOTE*–Do not over oil motor. Motor failure is more commonly caused by over lubrication than under lubrication.

- 1– Indoor Blower Motor Bearings – Bearings are pre-lubricated; no further lubrication is required.
- 3– Condenser Fan Motor Bearings –Bearings are pre-lubricated; no further lubrication is required.

### **B–Filters**

Inspect filters at least twice annually. Units equipped with optional status panel will indicate at the status panel when filters are dirty, or plugged, resulting restricted air flow. Replace the 16" X 20" X 1" (406 mm X 508 mm X 25 mm) frame type filter with equivalent filters available from your Lennox dealer.

*NOTE*–Filters must be U.L.C. certified or equivalent for use in Canada.

### **C–Outdoor Coil**

**CAUTION**–Disconnect power to unit before cleaning. Annually clean condenser coils with detergent or commercial coil cleaner and inspect monthly during the cooling season.