

Моноблочный насос

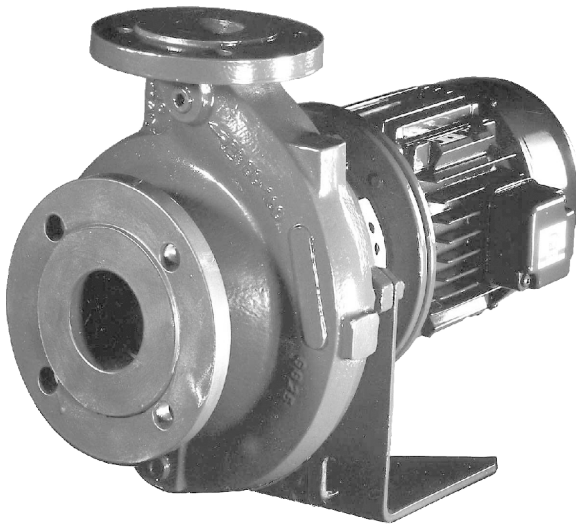

Области применения

- Водоснабжение
- Дождевание
- Орошение
- Водоотвод
- Отопление
- Кондиционирование
- Питьевая вода
- Техническая вода
- Горячая вода
- Охлаждающая вода
- Вода плавательных бассейнов
- Морская вода
- Вода для гашения
- Соленоватая вода
- Конденсат
- Рассол
- Масла
- Дeterгенты

Эксплуатационные данные

	50 Гц	60 Гц
Q	до 650 м ³ /ч, или 180 л/с	до 740 м ³ /ч, или 205 л/с
H	до 101 м	до 97 м
t	от -30 до +140 °С	
p ₂ 1)	до 16 бар	

1) см. предельные значения давления-/температуры на стр. 5

Условное обозначение

Типоряд _____ Etabloc G (N) 50-160 / 75 2
 Материал корпуса В. JL1040 2)
 Исполнение торцевого разьема вала
 со стандартным двигателем _____
 Типоразмер _____
 Мощность двигателя : _____
 Мощность двигателя кВт x 10 (пример: 7,5 кВт) _____
 Число пар полюсов электродвигателей _____

2) по EN 1561 = GJL0250

Уплотнение вала

Торцовое уплотнение по EN 12756.

Конструкция / Исполнение

Насос со спиральным корпусом, одноступенчатый ³⁾, с производительностью по EN 733. Вал в зоне уплотнения вала с взаимозаменяемыми втулкой вала, спиральным корпусом и рабочее колесо с взаимозаменяемым щелевым кольцом ⁴⁾.

3) Etabloc 32023 двухступенчатый

4) за исключением Etabloc 25020 и 32023

Etabloc GN, MN, SN, BN, CN

Насос и двигатель соединены фланцевым соединением в моноблочный агрегат, со стандартным электродвигателем. Вал насоса жестко связан с валом двигателя.

Etabloc G, M

Насос и двигатель соединены фланцевым соединением в моноблочный агрегат, с общим валом.

Привод

Стандартное исполнение Etabloc N

Короткозамкнутый электродвигатель KSB-IEC-трехфазный- с поверхностным охлаждением.

Обмотка: 50Гц до 2,2 кВт 220-240 В/380-420 В
 начиная с 3 кВт 380-420 В/660-725 В
 60Гц до 2,6 кВт 440-480 В
 начиная с 3,6 кВт 440-480 В

Конструктивное исполнение: до 4 кВт IM V1
 начиная с 5,5 кВт IM V15

степень защиты IP 55

Класс изоляции: F с термодатчиком: 3 термистора

Режим эксплуатации: Непрерывный режим S1
 или

Короткозамкнутый электродвигатель-трехфазный с поверхностным охлаждением как описано выше, любого Европейского производителя по нашему выбору.

Взрывозащищенное исполнение Etabloc N

Короткозамкнутый электродвигатель IEC-трехфазный с-поверхностным охлаждением, Европейского производителя по нашему выбору.

Обмотка: 50Гц до 1,85 кВт 220-240 В/380-420 В
 начиная с 2,5 кВт 380-420 В/660-725 В

Конструктивное исполнение: до 3,3 кВт IM V1
 начиная с 4,6 кВт IM V15

Степень защиты: IP 55 или IP 54

Тип взрывозащиты: EExe II

Температурный класс: T3

Режим эксплуатации: Непрерывный режим S1

Стандартное исполнение Etabloc G, M

Короткозамкнутый электродвигатель KSB-трехфазный с поверхностным охлаждением, с удлинителем вала, со специальным фланцем.

Обмотка: 50Гц до 2,2 кВт: 220-240 В / 380-420 В
 начиная с 3 кВт: 380-420 В / 660-725 В
 60Гц до 2,6 кВт 440-480 В
 начиная с 3,6 кВт 440-480 В

Конструктивное исполнение до 4 кВт без опорной лапы
 начиная с 5,5 кВт: с опорной лапы

степень защиты IP 55

Класс изоляции: F с термодатчиком: 3 позистора

Режим эксплуатации: Непрерывный режим S1

Защита от касания

Защитная крышка на колпаке привода по EN 294.

Поле характеристик

n = 2900 об/мин

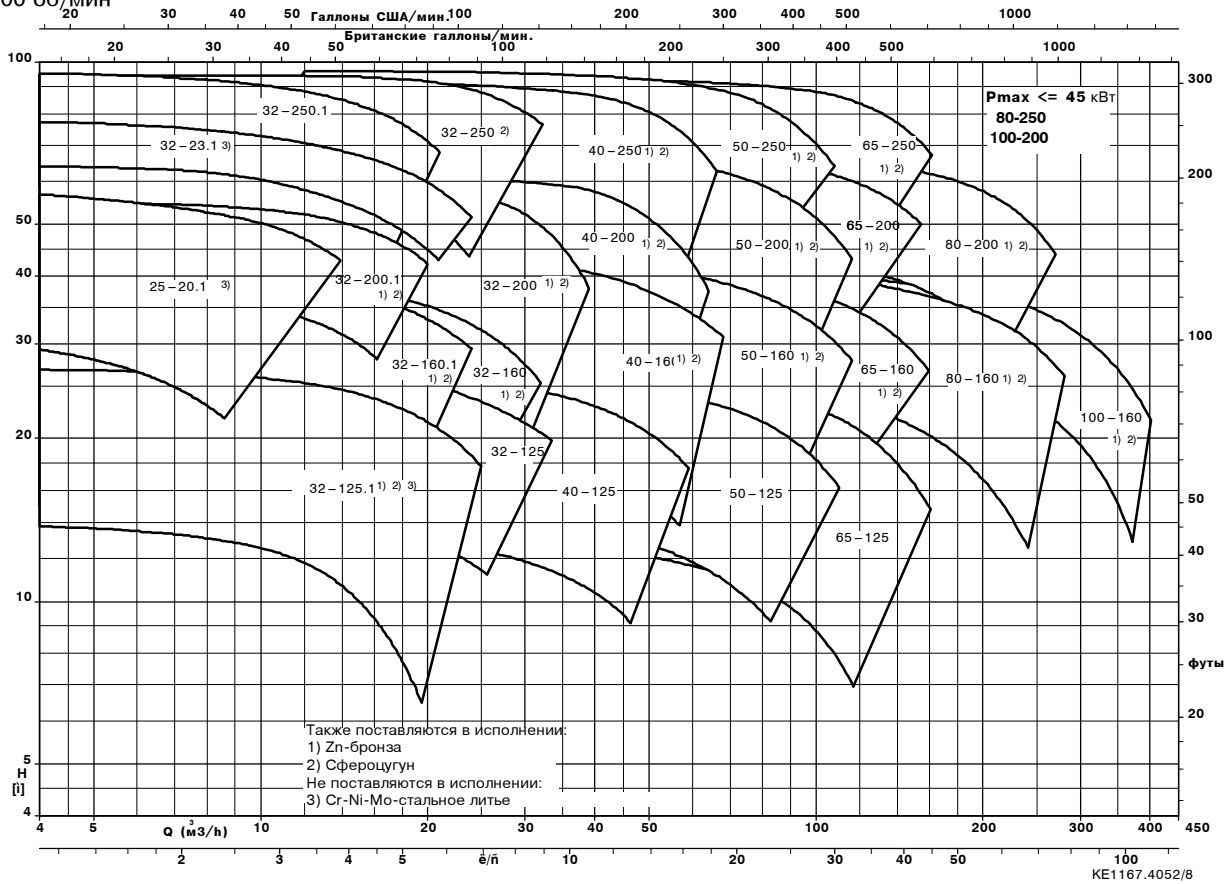

n = 1450 об/мин

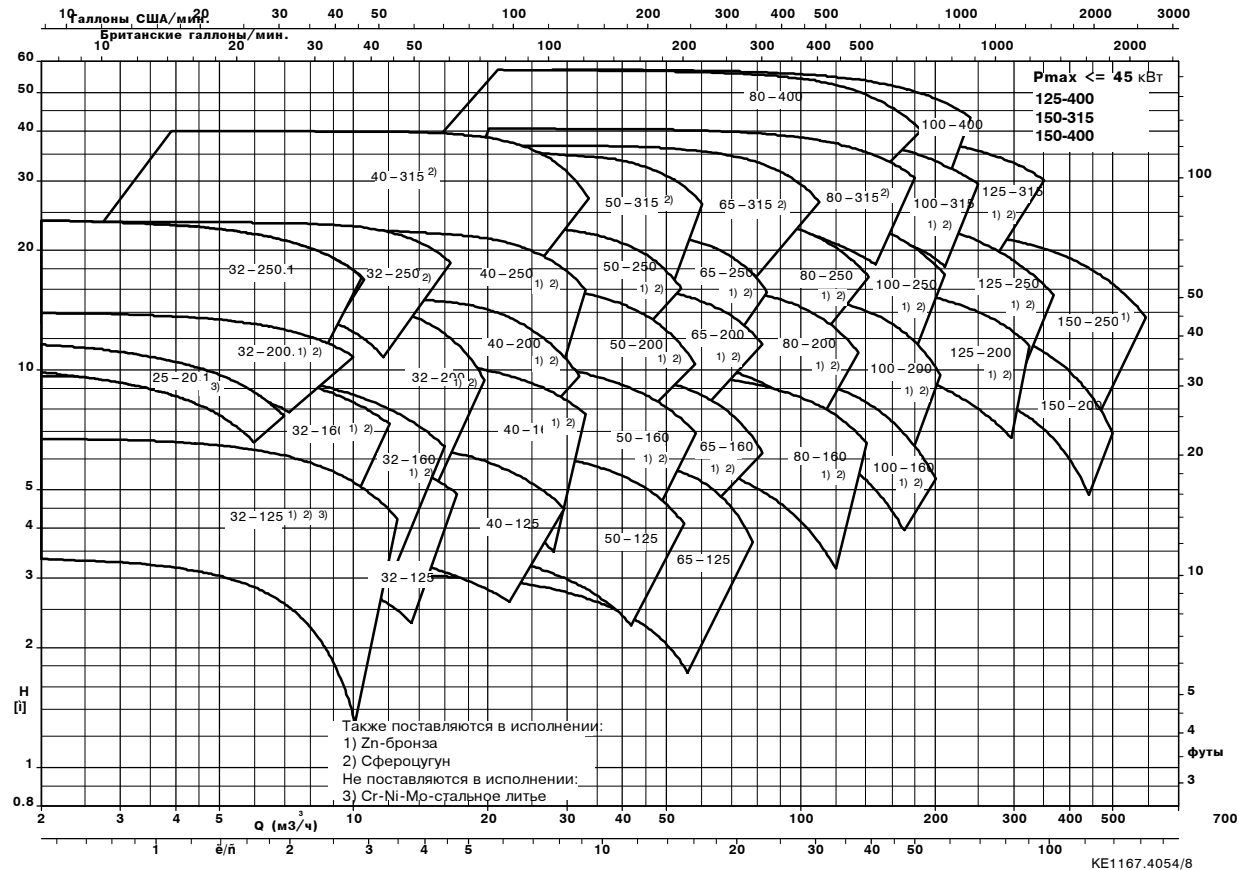

Поле характеристик

n = 3500 об/мин

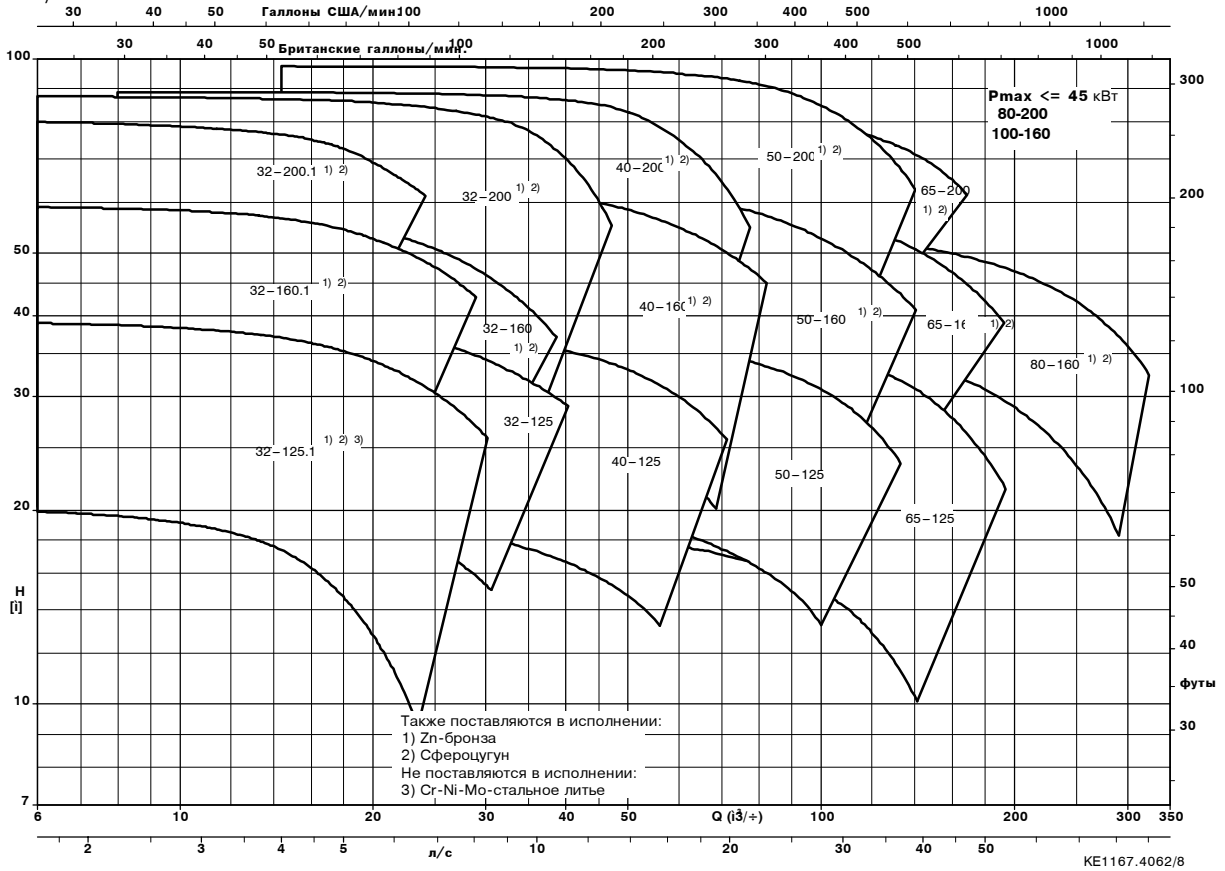

n = 1750 об/мин

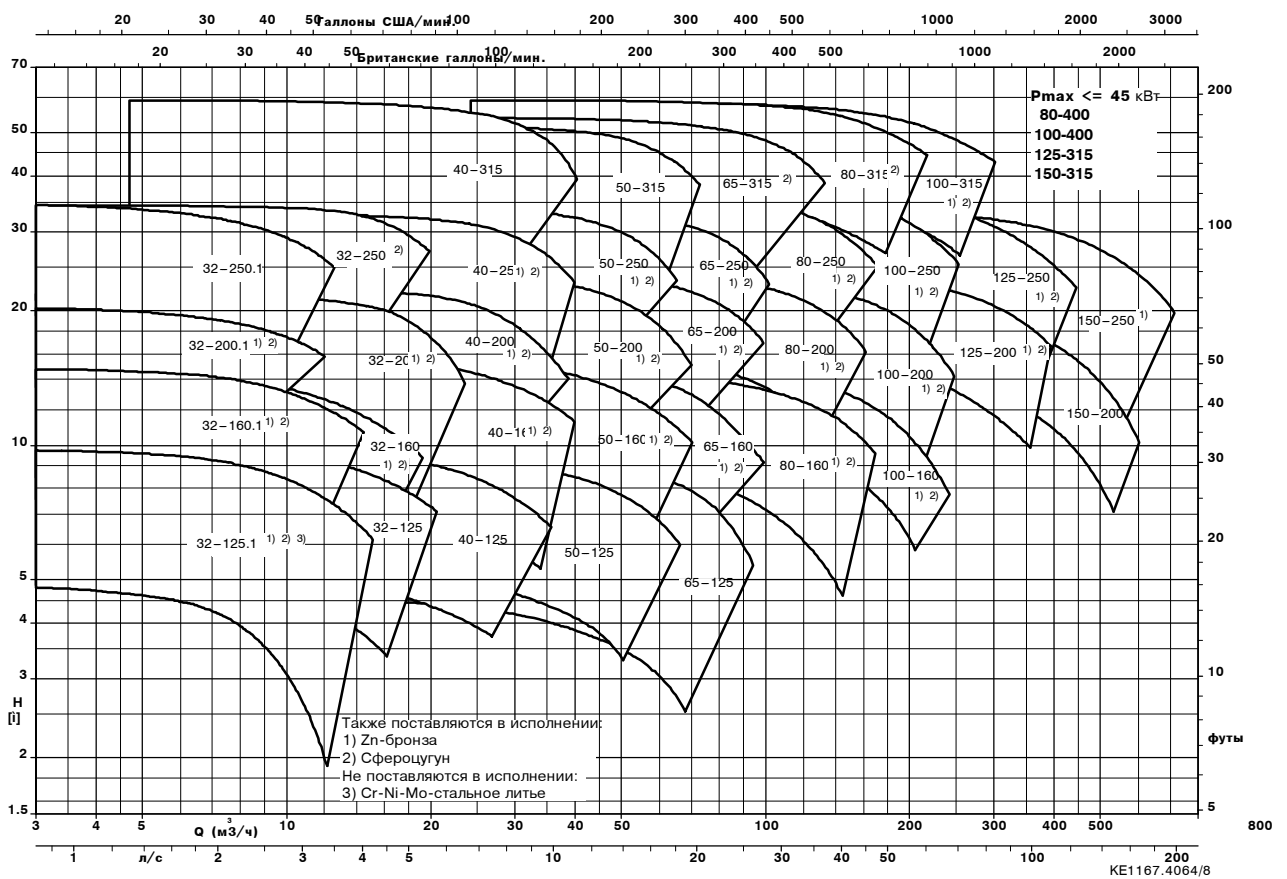

Материалы

	Etabloc G, GN	Etabloc M, MN	Etabloc BN
Спиральный корпус	Серый чугун JL1040 ¹⁾	Серый чугун JL1040 ¹⁾	Оловянистая бронза CC480K-GS ³⁾
Крышка корпуса насоса	Серый чугун JL1040 ¹⁾	Серый чугун JL1040 ¹⁾	Оловянистая бронза CC480K-GS ³⁾
Рабочее колесо	Серый чугун JL1040 ¹⁾	Оловянистая бронза CC480K-GS ³⁾	Оловянистая бронза CC480K-GS ³⁾
Щелевое кольцо	Серый чугун JL1040	Серый чугун/Свинцовистая бронза GG/CC495K-GS ³⁾	Свинцовистая бронза CC480K-GS ³⁾
Вал	Термически улучшенная сталь C45N	Термически улучшенная сталь C45N	Хром-никель-молибденовая-сталь 1.4571
Втулка вала	Хром-никель-молибденовая-сталь 1.4571	Хром-никель-молибденовая-сталь 1.4571	Хром-никель-молибденовая-сталь 1.4571
Колпак привода	Серый чугун JL1040 ¹⁾	Серый чугун JL1040 ¹⁾	Серый чугун JL1040 ¹⁾

	Etabloc SN	Etabloc CN
Спиральный корпус	Высокопрочный чугун с шаровидным графитом JS1025 ²⁾	Стальное литье из хром-никель-молибденовой-стали 1.4408
Крышка корпуса насоса	Высокопрочный чугун с шаровидным графитом JS1025 ²⁾	Стальное литье из хром-никель-молибденовой-стали 1.4408
Рабочее колесо	Серый чугун JL1040 ¹⁾	Стальное литье из хром-никель-молибденовой-стали 1.4408
Щелевое кольцо	Серый чугун JL1040	Стальное литье из хром-никель-молибденовой-стали 1.4408
Вал	Термически улучшенная сталь C45N	Хром-никель-молибденовая-сталь 1.4571
Втулка вала	Хром-никель-молибденовая-сталь 1.4571	Хром-никель-молибденовая-сталь 1.4571
Колпак привода	Серый чугун JL1040 ¹⁾	Серый чугун JL1040 ¹⁾

1) по EN 1561 = GJL-250

2) по EN 1563 = GJS-400-18-LT

3) по EN 1982

Etabloc N

Размеры **Выбор материала**, Серый чугун, оловянистая бронза, Высокопрочный чугун с шаровидным графитом Стальное литье из хром-никель-молибденовой-стали

Щелевое кольцо удобное в эксплуатации, отсутствие износа корпуса/рабочего колеса

Рабочее колесо с оптимизированной проточной частью, превосходный КПД

Геометрия подводящей линии из обеспечивает наивысшую всасывающую способность (NPSH) и наилучшую характеристику кавитационного запаса

Оболочка для работы под давлением на 16 бар обеспечивает высокую безопасность эксплуатации

Втулка вала предотвращает износ вала

Удобный в эксплуатации, надежный KSB-IEC-трехфазный электродвигатель

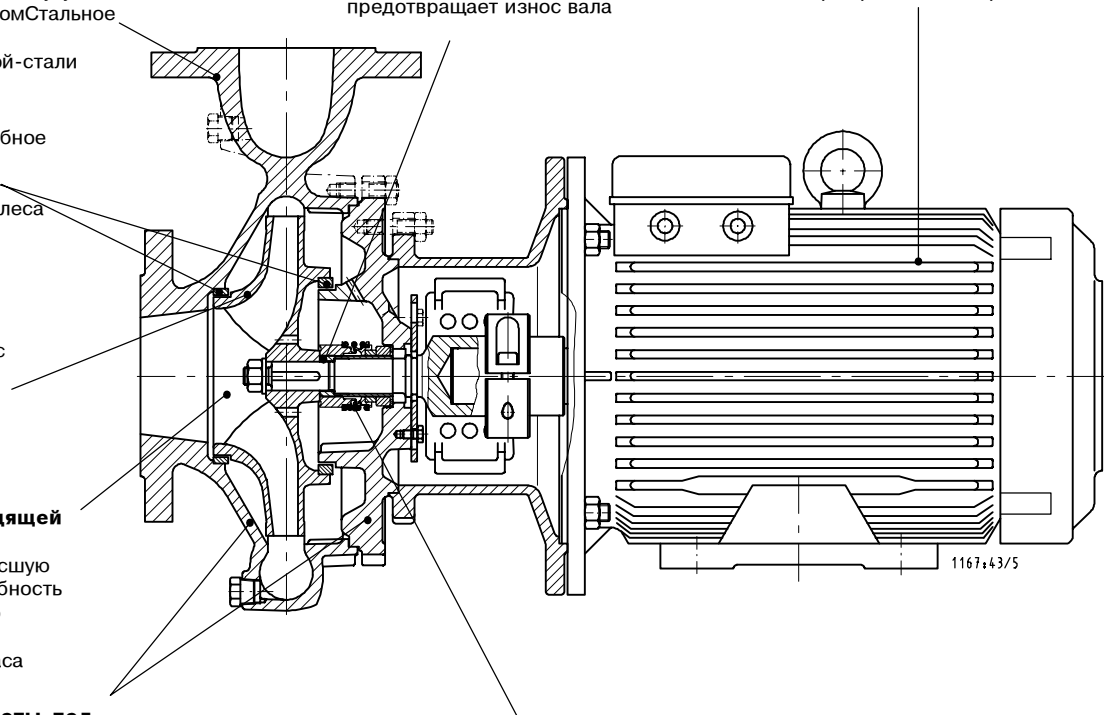

эксплуатационная надежность **Стандартное торцовое уплотнение**, не требует технического обслуживания

Предельные значения давления и температуры

Etabloc	Температура перекачиваемой среды ¹⁾⁴⁾	Конечное давление p ₂ ²⁾	Давление испытания ³⁾
G, GN	-30 °C 30 до +140 °C	5)	до 21 бар
M, MN	-30 °C 30 до +140 °C		до 21 бар
SN	-30 °C 30 до +140 °C		до 25 бар
BN	-30 °C 30 до +140 °C	10 бар	до 13 бар
CN	-30 °C 30 до +140 °C	5)	до 21 бар

- Для установок водяного отопления по DIN 4752, раздел 4.5, необходимо учитывать первоначальные предельные значения
- Сумма давления на входе и напора в нулевой точке не должна превосходить указанного значения на характеристике
- Узел корпуса путем испытания внутренним давлением по AN 1897/75-03 проверяется на непроницаемость по воде
- При температуре перекачиваемой среды > 140 °C для Etabloc SY, Etaline SY предусмотрено
- см. диаграмму характеристики

зависимость Давление-/Температура для фланцев согласно EN 1092-1 и EN 1092-2

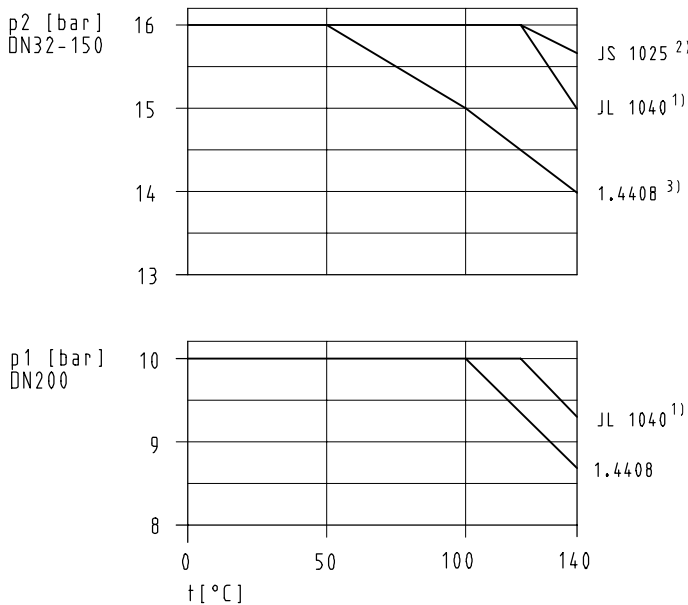

- по EN 1561 = JL 1040
- по EN 1563 = JS 1025
- только DN 65-150; DN 32-50 = 16 бар

12 11: 173/1

Подлежат поставке следующие типоразмеры Материалы

Типоразмер	Etabloc						
	G	GN	M	MN	SN	BN	CN
25-20.1/...	X	X	X	X	-	-	-
32-23.1/...	X	X	X	X	-	-	-
32-125.1/...	X	X	X	X	X	X	X
32-160.1/...	X	X	X	X	X	X	X
32-200.1/...	X	X	X	X	X	X	X
32-250.1/...	X	X	X	X	-	-	X
32-125/...	X	X	X	X	-	-	X
32-160/...	X	X	X	X	X	X	X
32-200/...	X	X	X	X	X	X	X
32-250/...	X	X	X	X	X	X	X
40-125/...	X	X	X	X	-	-	X
40-160/...	X	X	X	X	X	X	X
40-200/...	X	X	X	X	X	X	X
40-250/...	X	X	X	X	X	X	X
40-315/...	X	X	X	X	X	-	X
50-125/...	X	X	X	X	-	-	X
50-160/...	X	X	X	X	X	X	X
50-200/...	X	X	X	X	X	X	X
50-250/...	X	X	X	X	X	X	X
50-315/...	X	X	X	X	X	-	X
65-125/...	X	X	X	X	-	-	X
65-160/...	X	X	X	X	X	X	X
65-200/...	X	X	X	X	X	X	X
65-250/...	X	X	X	X	X	X	X
65-315/...	X	X	X	X	X	-	X
80-160/...	X	X	X	X	X	X	X
80-200/...	X	X	X	X	X	X	X
80-250/...	X	X	X	X	X	X	X
80-315/...	X	X	X	X	X	-	X
80-400/...	-	X	-	X	-	-	X
100-160/...	X	X	X	X	X	X	X
100-200/...	X	X	X	X	X	X	X
100-250/...	X	X	X	X	X	X	X
100-315/...	X	X	X	X	X	X	X
100-400/...	-	X	-	X	-	-	X
125-200/...	X	X	X	X	X	X	X
125-250/...	X	X	X	X	X	X	X
125-315/...	-	X	-	X	X	X	X
125-400/...	-	X	-	X	X	-	X
150-200/...	X	X	X	X	-	-	X
150-250/...	X	X	X	X	-	X	X
150-315/...	-	X	-	X	X	X	X

Перекачиваемая среда	Применение Границы рабочего диапазона	Материал Корпус/Рабочее колесо										Уплотнение вала Торцовое уплотнение	Коды исполнения	Сопутствующие документы
		Серый чугун/Серый чугун		Серый чугун/Оловянистая бронза		Высокопрочный чугун с шаровидным графитом/Серый чугун		Оловянистая бронза/Оловянистая бронза		CrNiMo-стальное литье/ CrNiMo-стальное литье				
		G, GN	M, MN	SN	BN	CN	6	9	10	11	12			
Вода														
Солоноватая вода ³⁾	t ≤ 25 °C p ≤ 10 бар				X					X		BN10	Стальное литье из хром-никель-молибденовой-стали возможно	
Вода для гашения ¹⁾	t ≤ 60 °C ^{б)} p ≤ 10 бар		X							X		M10, MN10	При поставке в соответствии с Директивой VdS-необходим запрос	
Отопительная вода 2)	t ≤ 120 °C p ≤ 10 бар	X								X		G11, GN11	Для применения в качестве циркуляционного насоса по DIN 4752; p _{max} ≥ 10 бар При перекачивании вязкого материала: «S»	
Отопительная вода 2)	t ≤ 140 °C p ≤ 16 бар	X					X					G6, GN6		
Отопительная вода 2)	t ≤ 110 °C p ≤ 10 бар	X						X				G10, GN10		
Конденсат 2)	t ≤ 120 °C p ≤ 10 бар	X								X		G11, GN11		
Конденсат не кондиционируемый	t ≤ 120 °C p ≤ 10 бар					X				X		CN11		
Охлаждающая вода ¹⁾ (без антифриза)	t ≤ 60 °C ^{б)} p ≤ 10 бар	X								X		G10, GN10	открытый циркуляционный контур: M10/MN10 предусмотрен	
Значение pH-для охлаждающей воды ≥ 7,5 (с антифризом)	t ≤ 30-110 °C p ≤ 10 бар	X								X		G11, GN11	открытый циркуляционный контур: M11/MN11 предусмотрен	
Слегка загрязненная вода ¹⁾	t ≤ 60 °C ^{б)} p ≤ 10 бар	X								X		G10, GN10		
Морская вода ³⁾	t ≤ 25 °C p ≤ 10 бар				X					X		BN10	Стальное литье из хром-никель-молибденовой-стали возможно	
Чистая вода ³⁾	t ≤ 60 °C ⁷⁾ p ≤ 10 бар	X								X		G11, GN11		
Сырая вода ¹⁾	t ≤ 60 °C ^{б)} p ≤ 10 бар	X								X		G10, GN10		
Вода плавательных бассейнов; Пресная вода ¹⁾	t ≤ 60 °C p ≤ 10 бар	X								X		G10, GN10	Указывается также при запросе согласно DIN 19 643	
Вода плавательных бассейнов; Морская вода ³⁾	t ≤ 40 °C p ≤ 10 бар				X					X		BN10	Стальное литье из хром-никель-молибденовой-стали при t ≤ +25 °C возможно	
Вода приплотинного водохранилища ¹⁾	t ≤ 60 °C ^{б)} p ≤ 10 бар		X							X		MN10	Если по запросу требуется твердый материал	
Питьевая вода ¹⁾	t ≤ 60 °C ⁷⁾ p ≤ 10 бар		X							X		MN11		
Частично обессоленная вода ²⁾	t ≤ 120 °C p ≤ 10 бар	X								X		G11, GN11		
Полностью обессоленная (VE-) вода	t ≤ 120 °C p ≤ 10 бар					X				X		CN11	Требования чистоты не выполнены	
Полностью обессоленная (VE-) вода в качестве питательной воды котлов ²⁾	t ≤ 120 °C p ≤ 10 бар	X								X		G11, GN11		
Хладагент, охлаждающий рассол														
Охлаждающий рассол, неорганический Значение pH ≤ 7,5	t -30 - +25 °C p ≤ 10 бар	X								X		G11, GN11		
В воде с антифризом значение pH ≥ 7,5 ¹⁾⁵⁾	t -30 - +110 °C p ≤ 10 бар	X								X		G11, GN11		

- Общие экспертные критерии при наличии анализа воды: Значение pH ≥ 7 ; Содержание в хлоридах (Cl) ≤ 250 мг/кг. Хлор (Cl₂) $\leq 0,6$ мг/кг.
- Подготовка по VdTUV 1466, дополнительно действительно содержание O₂ $\leq 0,02$ мг/л
- Для деталей из бронзы действительно: содержание аммиака (NH₃) ≤ 5 мг/кг, отсутствие сероводорода (H₂S); при этом перекрестное содержание Cl-падает. При несоблюдении предельных значений требуется запрос.
- Антифриз на этилен-гликолевой основе с ингибиторами. Содержание: >от 20 % до 50 % (например, Antifrogen N)
- Особой очистки воды не требуется! Электропроводность при 25 °C: ≤ 800 мСименс/см, нейтральность в коррозионно-химическом воздействии
- Торцовое уплотнение допускается при t ≤ 110 °C
- Торцовое уплотнение допускается при t ≤ 120 °C

Пример выбора:
Исходные данные: Чистая вода 15 °C; Q = 50 м³/час; H = 20 м

Найдено: Etabloc GN 40 - 125/402 GN 11

Материал или соответственно вариант исполнения (согласно вышеупомянутой Таблице)

Типоразмер (согласно характеристической линии 2900 об/мин)

Код исполнения (согласно вышеупомянутой Таблице)

Перекачиваемая жидкость	Пределы применения	Материал Корпус/Рабочее колесо					Уплотнение вала Торцовое уплотнение			Код исполнения	Указания
		Серый чугун/Серый чугун	Серый чугун/Оловянистая бронза	Высокопрочный чугун с шаровидным графитом/Серый чугун	Оловянистая бронза/Оловянистая бронза	СтNiMo-Стальное литье/СтNiMo-Стальное литье	U3U3VGG	Q1Q1X4GG	Q1Q1M1 GG		
		G, G N	M, MN	SN	BN	CN	9	10	12		
Масла/Эмульсии											
Солянка, мазут EL	t ≤ 60 °C p ≤ 10 бар			X				X		SN10	Серый чугун возможен, если не требуется соблюдать никаких предписаний
Смазочное масло, турбинное масло действительно не для SF-D-масел (трудновоспламеняющиеся горючие)	t ≤ 80 °C p ≤ 10 бар			X				X		SN10	При перекачивании [без] внутренней грунтовки требуется запрос. Серый чугун возможен, если не требуется соблюдать никаких предписаний
Сверлильная-/шлифовальная эмульсия	t ≤ 60 °C p ≤ 10 бар	X					X			G9, GN9	
Масло-Вода-Эмульсия	t ≤ 60 °C p ≤ 16 бар	X					X			G9, GN9	
Детергент											
Щелок для бутылко-промывочной машины	t ≤ 90 °C p ≤ 10 бар	X								G7, GN7	Q ₁ Q ₁ EGG
Применение в пивоварении											
Пивное сусло	t ≤ 100 °C p ≤ 10 бар	X							X	GN 12	При опасности сухого хода из-за чрезмерного вытекания из сосудов следует применять Etabloc или Etanorm с двойным уплотнением в тандемной-компоновке
Пивное сусло	t ≤ 100 °C p ≤ 10 бар	X							X	GN 12	

Пример выбора:
Исходные данные: Мазут 15 °C; Q = 50 м³/час; H = 20 м

Найдено: Etabloc SN 40 - 125/402 SN 10

Материал или соответственно вариант исполнения (согласно вышеупомянутой Таблице)

Типоразмер (согласно характеристической линии 2900 об/мин)

Код исполнения (согласно вышеупомянутой Таблице)

Etabloc G, M 25-20.1, 32-23.1

Перекачиваемая жидкость	Пределы применения	Материал Корпус / рабочее колесо		Уплотнение вала / торцовое уплотнение			Исполнение:	Указания
		Серый чугун / Серый чугун	Серый чугун / Оловянистая бронза	U3U3VGG	Q1Q1X4GG	BQ1EGG		
		G	M	9	10	11		
Вода								
Вода для пожаротушения ¹⁾	t ≤ 60°C ⁶⁾ p ≤ 10 бар		X		X		M10	При поставке в соответствии с Директивой VdS-требуется запрос
Вода системы отопления ²⁾	t ≤ 110°C p ≤ 10 бар	X				X	G10	При применении в качестве циркуляционного насоса по DIN 4752, p _{max} ≤ 10 бар
Конденсат ²⁾	t ≤ 110°C p ≤ 10 бар	X				X	G11	
Охлаждающая вода ¹⁾ (без антифриза)	t ≤ 60°C ⁶⁾ p ≤ 10 бар	X			X		G10	открытый циркуляционный контур: M 10 предусмотрен
Значение pH-для охлаждающей воды ≥ 7,5 (с антифризом) ⁴⁾	t -30 - +110°C p ≤ 10 бар	X				X	G11	Открытый циркуляционный контур: M 11 предусмотрен
Слегка загрязненная вода ¹⁾	t ≤ 60°C ⁶⁾ p ≤ 10 бар	X			X		G10	
Чистая вода	t ≤ 60°C ⁷⁾ p ≤ 10 бар	X				X	G11	Особой очистки воды не требуется
Сырая вода ¹⁾	t ≤ 60°C ⁶⁾ p ≤ 10 бар	X			X		G10	
Вода плавательных бассейнов ¹⁾ Пресная вода	t ≤ 60°C p ≤ 10 бар	X			X		G10	Действительно также согласно требованиям по DIN 19643
Вода приплотинного водохранилища ¹⁾	t ≤ 60°C ⁶⁾ p ≤ 10 бар		X		X		M10	Если по запросу требуется твердый материал
Питьевая вода ¹⁾	t ≤ 60°C ⁷⁾ p ≤ 10 бар		X			X	M11	
Частично опресненная вода ²⁾	t ≤ 120°C p ≤ 10 бар	X				X	G11	
Полностью обессоленная (VE-) вода в качестве питательной воды котлов ²⁾	t ≤ 120°C p ≤ 10 бар	X				X	G11	
Хладагент, охлаждающий рассол								
Охлаждающий рассол, неорганический Значение-pH ≥ 7,5	t -30 - +25°C p ≤ 10 бар	X				X	G11	
Вода с антифризом Значение-pH ≥ 7,5 ¹⁾⁵⁾	t -30 - +110°C p ≤ 10 бар	X				X	G11	
Масла/Эмульсии								
Сверлильная-/шлифовальная эмульсия	t ≤ 60°C p ≤ 10 бар	X		X			G9	
Масло-Вода-Эмульсия	t ≤ 60°C p ≤ 10 бар	X		X			G9	
Детергент								
Щелок для бутылко-промывочной машины	t ≤ 90°C p ≤ 10 бар	X					G7	Q ₁ Q ₁ EGG

- Общие экспертные критерии при наличии анализа воды: Значение pH ≥ 7; Содержание в хлоридах (Cl) ≤ 250 мг/кг. Хлор (Cl₂) ≤ 0,6 мг/кг.
- Подготовка по VdTUV 1466, дополнительно действительно содержание O₂ ≤ 0,02 мг/л
- Для деталей из бронзы действительно: содержание аммиака (NH₃) ≤ 5 мг/кг, отсутствие сероводорода (H₂S); при этом перекрестное содержание Cl-падает. При несоблюдении предельных значений требуется запрос.
- Антифриз на этилен-гликолевой основе с ингибиторами. Содержание: >от 20 % до 50 % (например, Antifrogen N)
- Электропроводность при 25 °C: ≤ 800 мСименс/см, нейтральность в коррозионно-химическом воздействии
- Торцовое уплотнение допускается при t ≤ 110 °C
- Торцовое уплотнение допускается при t ≤ 120 °C

Пример выбора:
Исходные данные: Чистая вода 15 °C; Q = 10 м³/час; H = 41 м

Найдено:
Материал или соответственно вариант исполнения (согласно вышеупомянутой Таблице) Etabloc GN 25 - 20.1/302 G 11
Типоразмер (согласно характеристической линии 2900 об/мин) _____
Код исполнения (согласно вышеупомянутой Таблице) _____

Etabloc	Ⓜ	50 Гц кВт	60 Гц кВт	50Гц, 400В; 60Гц, 460В; ≈А ²)
2 - полюсный				
25-20.1/152	90S	1,5		3,4
25-20.1/222	90L	2,2		4,6
25-20.1/302	100L	3,0		6,3
25-20.1/402	112M	4,0		8,3
32-23.1/402 ¹⁾	112M	4,0		8,3
32-23.1/552 ¹⁾	112L	5,5		11
32-125.1/072	80	0,75		1,8
32-125.1/112	80	1,1	1,3	2,6
32-125.1/152	90S	1,5	1,75	3,4
32-125.1/222	90L	2,2	2,55	4,6
32-125.1/302	100L		3,45	6,3
32-125.1/402	112M		4,6	8,3
32-125.1/552	132S		6,3	11
32-160.1/152	90S	1,5		3,4
32-160.1/222	90L	2,2	2,55	4,6
32-160.1/302	100L	3,0	3,45	6,3
32-160.1/402	112M	4,0	4,6	8,3
32-160.1/552	132S		6,3	11
32-160.1/752	132S		8,6	14,6
32-200.1/302	100L	3,0		6,3
32-200.1/402	112M	4,0	4,6	8,3
32-200.1/552	132S	5,5	6,3	11
32-200.1/752	132S		8,6	14,6
32-200.1/1102	160M		12,6	20,7
32-200.1/1502	160M		17,3	28
32-250.1/552	132S	5,5		11
32-250.1/752	132S	7,5		14,6
32-250.1/1102	160M	11		20,7
32-250.1/1502	160M	15		28
32-125/112	80	1,1		2,6
32-125/152	90S	1,5	1,75	3,4
32-125/222	90L	2,2	2,55	4,6
32-125/302	100L	3,0	3,45	6,3
32-125/402	112M		4,6	8,3
32-125/552	132S		6,3	11
32-160/222	90L	2,2		4,6
32-160/302	100L	3,0	3,45	6,3
32-160/402	112M	4,0	4,6	8,6
32-160/552	132S		6,3	11
32-160/752	132S		8,6	14,6
32-200/402	112M	4,0		8,3
32-200/552	132S	5,5	6,3	11
32-200/752	132S	7,5	8,6	14,6
32-200/1102	160M	11	12,6	20,7
32-200/1502	160M		17,3	28
32-250/752	132S	7,5		14,6
32-250/1102	160M	11		20,7
32-250/1502	160M	15		28
40-125/152	90S	1,5		3,4
40-125/222	90L	2,2	2,55	4,6
40-125/302	100L	3,0	3,45	6,3
40-125/752	132S		8,6	65,0
40-125/1102	160M		12,6	14,6
40-160/302	100L	3,0		6,3
40-160/402	112M	4,0	4,6	8,3
40-160/552	132S	5,5	6,3	11
40-125/402	112M	4,0	4,6	8,3
40-125/552	132S		6,3	11
40-160/752	132S	7,5	8,6	14,6
40-160/1102	160M	11	12,6	20,7
40-160/1502	160M		17,3	28
40-200/552	132S	5,5		11

Etabloc	Ⓜ	50 Гц кВт	60 Гц кВт	50Гц, 400В; 60Гц, 460В; ≈А ²)
2 - полюсный				
40-200/752	132S	7,5	8,6	14,6
40-200/1102	160M	11	12,6	20,7
40-200/1502	160M	15	17,3	28
40-200/1852	160L		21,3	33
40-200/2202	180M		24,5	40
40-250/1102	160M	11		20,7
40-250/1502	160M	15		28
40-250/1852	160L	18,5		33
40-250/2202	180M	22		40
50-125/302	100L	3,0		6,3
50-125/402	112M	4,0		8,3
50-125/552	132S	5,5	6,3	11
50-125/752	132S	7,5	8,6	14,6
50-125/1102	160M		12,6	20,7
50-125/1502	160M		17,3	28
50-160/552	132S	5,5	6,3	11
50-160/752	132S	7,5	8,6	14,6
50-160/1102	160M	11	12,6	20,7
50-160/1502	160M	15	17,3	28
50-160/1852	160L		21,3	33
50-160/2202	180M		24,5	40
50-200/1102	160M	11	12,6	20,7
50-200/1502	160M	15	17,3	28
50-200/1852	160L	18,5	21,3	33
50-200/2202	180M	22	24,5	40
50-200/3002	200L		34,5	54
50-200/3702	200L		42,5	65
50-250/1502	160M	15		28
50-250/1852	160L	18,5		33
50-250/2202	180M	22		40
50-250/3002	200L	30		54
50-250/3702	200L	37		65
65-125/402	112M	4,0		8,3
65-125/552	132S	5,5	6,3	11
65-125/752	132S	7,5	8,6	14,6
65-125/1102	160M	11	12,6	20,7
65-125/1502	160M		17,3	28
65-160/752	132S	7,5		14,6
65-160/1102	160M	11	12,6	20,7
65-160/1502	160M	15	17,3	28
65-160/1852	160L		21,3	33
65-160/2202	180M		24,5	40
65-160/3002	200L		34,5	54
65-200/1502	160M	15		28
65-200/1852	160L	18,5	21,3	33
65-200/2202	180M	22	24,5	40
65-200/3002	200L		34,5	54
65-200/3702	200L		42,5	65
65-250/2202	180M	22		40
65-250/3002	200L	30		54
65-250/3702	200L	37		65
65-250/4502	225M	45		78
80-160/1102	160M	11		20,7
80-160/1502	160M	15		28
80-160/1852	160L	18,5		33
80-160/2202	180M	22	24,5	40
80-160/3002	200L	30	34,5	54
80-160/3702	200L		42,5	65
80-200/1852	160L	18,5		33
80-200/2202	180M	22		40
80-200/3002	200L	30		54
80-200/3702	200L	37		65

1) двухступенчатый

2) Указанные величины тока в А являются ориентировочными значениями. Точные значения тока Вы можете найти на Табличке мощности на электродвигателе.

Etabloc	Ⓜ	50 Гц	60 Гц	50Гц, 400В; 60Гц, 460В; ≈А ²)
		кВт	кВт	
2 - полюсный				
80-200/4502	225M	45	52	78
80-250/3002	200L	30		54
80-250/3702	200L	37		65
80-250/4502	225M	45		78
100-160/2202	180M	22		40
100-160/3002	200L	30		54
100-160/3702	200L	37	42,5	65
100-160/4502	225M		52	78
100-200/3002	200L	30		54
100-200/3702	200L	37		65
100-200/4502	225M	45		78

Etabloc	Ⓜ	50 Гц	60 Гц	50Гц, 400В; 60Гц, 460В; ≈А ²)
		кВт	кВт	
4 - полюсный				
25-20.1/034	71	0,37		1,2
32-125.1/024	71	0,25	0,30	0,8
32-125.1/034	71	0,37	0,43	1,2
32-125.1/054	80	0,55	0,63	1,6
32-160.1/034	71	0,37	0,43	1,2
32-160.1/054	80	0,55	0,63	1,6
32-160.1/074	80		0,88	2,0
32-160.1/114	90S		1,30	2,8
32-200.1/054	80	0,55	0,63	1,6
32-200.1/074	80	0,75	0,88	2,0
32-200.1/114	90S		1,30	2,8
32-200.1/154	90L		1,75	3,6
32-200.1/224	100L		2,55	5,1
32-250.1/074	80	0,75		2,0
32-250.1/114	90S	1,1	1,30	2,8
32-250.1/154	90L	1,5	1,75	3,6
32-250.1/224	100L		2,55	5,1
32-250.1/304	100L		3,45	6,7
32-125/034	71	0,37	0,43	1,2
32-125/054	80	0,55	0,63	1,6
32-125/074	80		0,88	2,0
32-160/054	80	0,55	0,63	1,6
32-160/074	80		0,88	2,0
32-160/114	90S		1,30	2,8
32-200/054	80	0,55		1,6
32-200/074	80	0,75	0,88	2,0
32-200/114	90S	1,1	1,30	2,8
32-200/154	90L		1,75	3,6
32-200/224	100L		2,55	5,1
32-250/114	90S	1,1		2,8
32-250/154	90L	1,5		3,6
32-250/224	100L	2,2	2,55	5,1
32-250/304	100L		3,45	6,7
32-250/404	112M		4,60	8,8
32-250/554	132S		6,30	11,5
40-125/024	71	0,25		0,8
40-125/034	71	0,37		1,2
40-125/054	80	0,55	0,63	1,6
40-125/074	80		0,88	2,0
40-125/114	90S		1,30	2,8
40-160/054	80	0,55		1,6
40-160/074	80	0,75	0,88	2,0
40-160/114	90S	1,1	1,30	2,8
40-160/154	90L		1,75	3,6
40-160/224	100L		2,55	5,1

Etabloc	Ⓜ	50 Гц	60 Гц	50Гц, 400В; 60Гц, 460В; ≈А ²)
		кВт	кВт	
4 - полюсный				
40-200/074	80	0,75		2,0
40-200/114	90S	1,1		2,8
40-200/154	90L	1,5	1,75	3,6
40-200/224	100L		2,55	5,1
40-200/304	100L		3,45	6,7
40-250/114	90S	1,1		2,8
40-250/154	90L	1,5		3,6
40-250/224	100L	2,2	2,55	5,1
40-250/304	100L	3,0	3,45	6,7
40-250/404	112M		4,60	8,8
40-250/554	132S		6,30	11,5
40-315/224	100L	2,2		5,1
40-315/304	100L	3,0		6,7
40-315/404	112M	4,0	4,6	8,8
40-315/554	132S	5,5	6,3	11,5
40-315/754	132M		8,6	15,5
40-315/1104	160M		12,6	21,5
50-125/054	80	0,55		1,6
50-125/074	80	0,75	0,88	2,0
50-125/114	90S	1,1	1,30	2,8
50-125/154	90L		1,75	3,6
50-160/074	80	0,75		2,0
50-160/114	90S	1,1	1,30	2,8
50-160/154	90L	1,5	1,75	3,6
50-160/224	100L		2,55	5,1
50-160/304	100L		3,45	6,7
50-200/154	90L	1,5		3,6
50-200/224	100L	2,2	2,55	5,1
50-200/304	100L	3,0	3,45	6,7
50-200/404	112M		4,60	8,8
50-200/554	132S		6,30	11,5
50-250/224	100L	2,2		5,1
50-250/304	100L	3,0		6,7
50-250/404	112M	4,0	4,6	8,8
50-250/554	132S		6,3	11,5
50-250/754	132M		8,6	15,5
50-250/1104	160M		12,6	21,5
50-315/304	100L	3		6,7
50-315/404	112M	4		8,8
50-315/554	132S	5,5	6,3	11,5
50-315/754	132M	7,5	8,6	15,5
50-315/1104	160M		12,6	21,5
50-315/1504	160L		17,3	28,5
65-125/054	80	0,55		1,6
65-125/074	80	0,75	0,88	2,0
65-125/114	90S	1,1	1,30	2,8
65-125/154	90L		1,75	3,6
65-125/224	100L		2,55	5,1
65-160/114	90S	1,1		2,8
65-160/154	90L	1,5	1,75	3,6
65-160/224	100L	2,2	2,55	5,1
65-160/304	100L		3,45	6,7
65-160/404	112M		4,60	8,8
65-200/224	100L	2,2		5,1
65-200/304	100L	3,0		6,7
65-200/404	112M	4,0	4,6	8,8
65-200/554	132S		6,3	11,5
65-200/754	132M		8,6	15,5
65-250/304	100L	3,0		6,7
65-250/404	112M	4,0		8,8
65-250/554	132S	5,5	6,3	11,5
65-250/754	132M		8,6	15,5

1) двухступенчатый

2) Указанные величины тока в А являются ориентировочными значениями. Точные значения тока Вы можете найти на Табличке мощности на электродвигателе.

Etabloc	M	50 Гц кВт	60 Гц кВт	50Гц, 400В; 60Гц, 460В; $\approx A^2$)
4 - полюсный				
65-250/1104	160M		12,6	21,5
65-315/554	132S	5,5		11,5
65-315/754	132M	7,5		15,5
65-315/1104	160M	11	12,6	21,5
65-315/1504	160L	15	17,3	28,5
65-315/1854	180M		21,3	35
65-315/2204	180L		25,3	42
80-160/154	90L	1,5		3,6
80-160/224	100L	2,2		5,1
80-160/304	100L	3,0		6,7
80-160/404	112M	4,0	4,6	8,8
80-160/554	132S		6,3	15,5
80-200/224	100L	2,2		5,1
80-200/304	100L	3,0		6,7
80-200/404	112M	4,0		8,8
80-200/554	132S	5,5	6,3	11,5
80-200/754	132M		8,6	15,5
80-200/1104	160M		12,6	21,5
80-250/404	112M	4,0		8,8
80-250/554	132S	5,5		11,5
80-250/754	132M	7,5	8,6	15,5
80-250/1104	160M	11	12,6	21,5
80-250/1504	160L		17,3	28,5
80-250/1854	180M		21,3	35
80-315/754	132M	7,5		15,5
80-315/1104	160M	11		21,5
80-315/1504	160L	15	17,3	28,5
80-315/1854	180M	18,5	21,3	35
80-315/2204	180L	22	25,3	42
80-315/3004	200L		34,5	56
80-315/3704	225S		42,5	67
80-400/3004	200L	30	34,5	56
80-400/3704	225S		42,5	67
80-400/4504	225M		52	81
100-160/304	100L	3,0		6,7
100-160/404	112M	4,0		8,8
100-160/554	132S	5,5	6,3	11,5
100-160/754	132M		8,6	15,5
100-200/404	112M	4,0		8,8
100-200/554	132S	5,5		11,5
100-200/754	132M	7,5	8,6	15,5
100-200/1104	160M		12,6	21,5
100-200/1504	160L		17,3	28,5
100-250/754	132M	7,5		15,5
100-250/1104	160M	11	12,6	21,5
100-250/1504	160L	15	17,3	28,5
100-250/1854	180M		21,3	35
100-250/2204	180L		25,3	42
100-315/1504	160L	15		28,5
100-315/1854	180M	18,5	21,3	35
100-315/2204	180L	22	25,3	42
100-315/3004	200L	30	34,5	56
100-315/3704	225S		42,5	67
100-315/4504	225M		52	81
100-400/3004	200L	30		56
100-400/3704	225S	37	42,5	67
100-400/4504	225M		52	81
125-200/754	132M	7,5		15,5
125-200/1104	160M	11	12,6	21,5
125-200/1504	160L	15	17,3	28,5
125-200/1854	180M		21,3	35
125-200/2204	180L		25,3	42

Etabloc	M	50 Гц кВт	60 Гц кВт	50Гц, 400В; 60Гц, 460В; $\approx A^2$)
4 - полюсный				
125-250/1104	160M	11		21,5
125-250/1504	160L	15	17,3	28,5
125-250/1854	180M	18,5	21,3	35
125-250/2204	180L	22	25,3	42
125-250/3004	200L		34,5	56
125-250/3704	225S		42,5	67
125-315/3004	200L	30		56
125-315/3704	225S	37	42,5	67
125-315/4504	225M		52	81
125-400/3004	200L	30		56
125-400/3704	225S	37		67
125-400/4504	225M	45		81
150-200/754	132M	7,5		15,5
150-200/1104	160M	11		21,5
150-200/1504	160L	15	17,3	28,5
150-200/1854	180M		21,3	35
150-200/2204	180L		25,3	42
150-250/1504	160L	15		28,5
150-250/1854	180M	18,5		35
150-250/2204	180L	22	25,3	42
150-250/3004	200L	30	34,5	56
150-250/3704	225S		42,5	67
150-250/4504	225M		52	81
150-315/3004	200L	30		56
150-315/3704	225S	37	42,5	67
150-315/4504	225M	45	52	81

2) Указанные величины тока в А являются ориентировочными значениями. Точные значения тока Вы можете найти на Табличке мощности на электродвигателе.

Etabloc G, M

до типоразмера электродвигателя 112 = 4 кВт

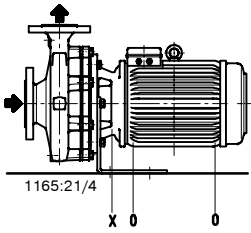

Состав поставки
Горизонтальная установка, крепление снизу

до типоразмера электродвигателя 112 = 4 кВт

Типоразмеры электродвигателя от 132 = 5,5 кВт до 180 = 22 кВт

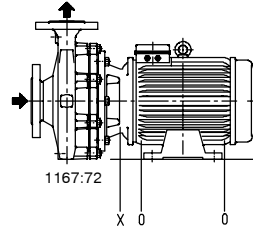

Вертикальная установка с электродвигателем сверху, требуется запрос

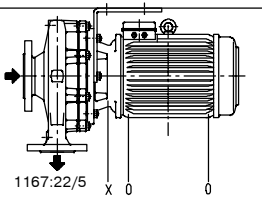

Положение отверстий для конденсированной воды
o = открыты
x = закрыты

Горизонтальная установка, крепление сверху.
Электродвигатель должен быть повернут на 180°

Etabloc GN, MN, BN¹⁾, SN¹⁾, CN¹⁾

до типоразмера электродвигателя 112 = 4 кВт

Типоразмеры электродвигателя от 132 = 5,5 кВт до 180 = 22 кВт

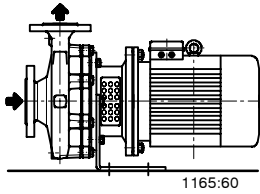

Состав поставки
Горизонтальная установка, крепление снизу

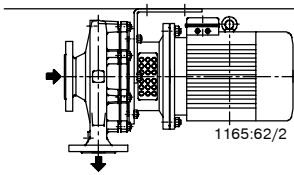
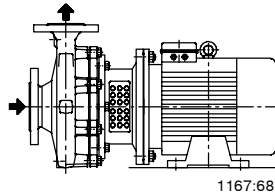

Горизонтальная установка, крепление сверху.
Электродвигатель должен быть повернут на 180°

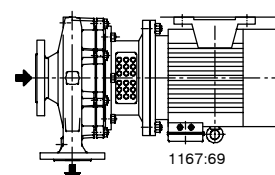

Etabloc GN, MN, BN¹⁾, SN¹⁾

при Etabloc CN требуется запрос

Типоразмер электродвигателя 112 = 4 кВт

Типоразмер электродвигателя от 132 = 5,5 кВт до 180 = 22 кВт

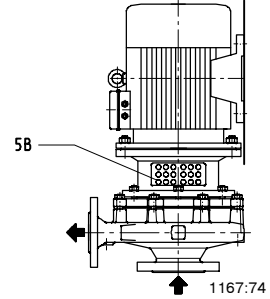
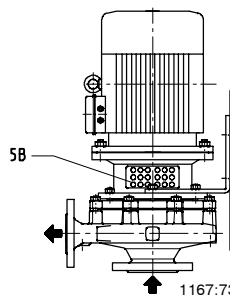

При вертикальной установке предусмотрен клапан выпуска воздуха для предотвращения сухого хода торцевого уплотнения.

Etabloc GN¹⁾, MN¹⁾, SN¹⁾, CN¹⁾

до типоразмеров электродвигателя от 200 = 30 кВт до 225 = 45 кВт

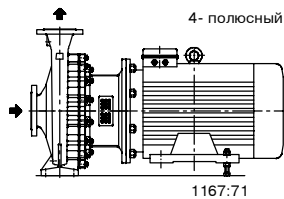
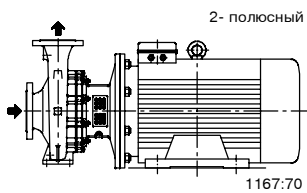

Состав поставки
Горизонтальная установка, крепление снизу

1) Спиральный корпус с опорной лапой

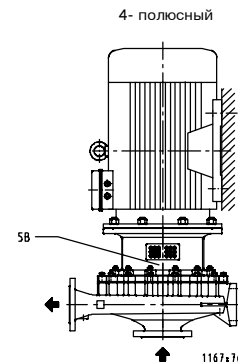
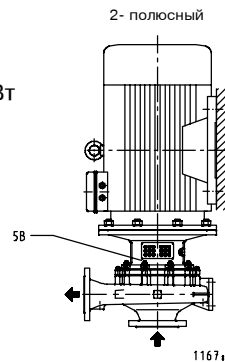

При вертикальной установке предусмотрен клапан выпуска воздуха для предотвращения сухого хода торцевого уплотнения

Etabloc G, M 25-20.1/... до 32-160//..., n = 2900 об/мин, n = 3500 об/мин

с опорными лапами (до типоразмера электродвигателя 112 = 4 кВт)
с опорной лапой электродвигателя
(начиная с типоразмера электродвигателя 132 = 5,5 кВт)

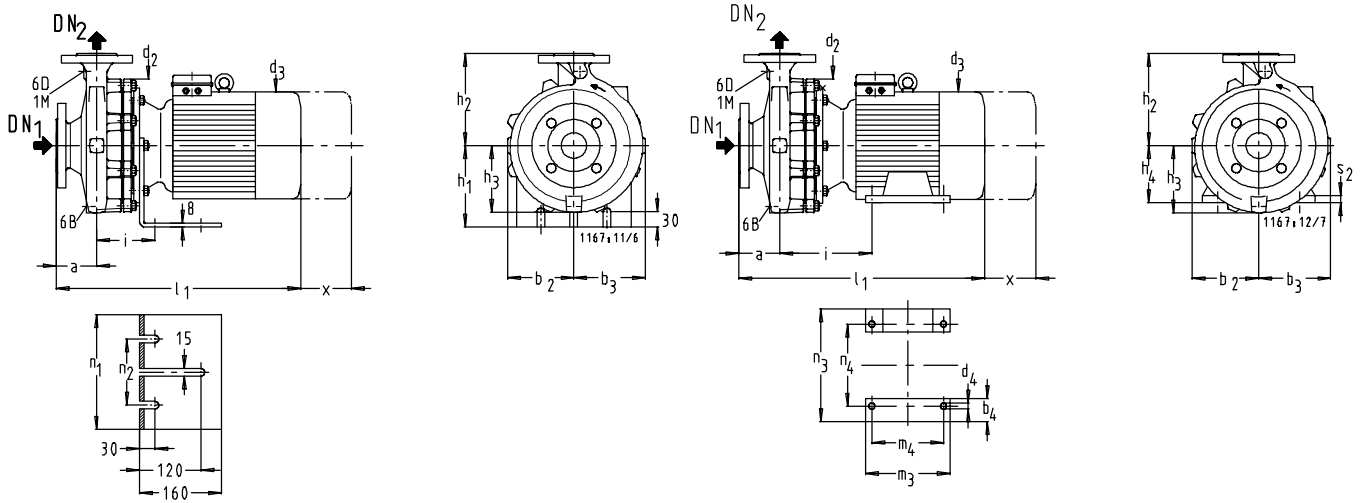

		Etabloc G, M		Etabloc SN, CN	
		Etabloc GN, MN, BN		DN ₂ 32 - DN ₂ 80	DN ₂ 100 - DN ₂ 150
1 M	Присоединение манометра	Rc 3/8 ¹⁾	Rc 1/2 ¹⁾	G 3/8 ¹⁾	G 1/2 ¹⁾
6 B	Перекачиваемая жидкость-Опорожнение	Rc 3/8 ¹⁾	Rc 1/2 ¹⁾	G 3/8 ¹⁾	G 1/2 ¹⁾
6 D	Перекачиваемая жидкость-Заполнение и опорожнение	Rc 3/8 ¹⁾	Rc 1/2 ¹⁾	G 3/8 ¹⁾	G 1/2 ¹⁾

Etabloc G, M		n		Допуски присоединительных размеров по EN 735																							
М	М	2900	3500	DN ₁	DN ₂	a	b ₂ ≈	b ₃ ≈	b ₄ ≈	d ₂	d ₃ ≈	d ₄	h ₁	h ₂	h ₃	h ₄	i	l ₁ ≈	m ₃ ≈	m ₄	h ₁	n ₂	n ₃ ≈	n ₄	s ₂	x	
25-20.1/152	90S	x		40	25	90	140	140		215	178		150	175	140		105	436				214	130				145
25-20.1/222	90L	x		40	25	90	140	140		215	178		150	175	140		105	361				214	130				145
25-20.1/302	100L	x		40	25	90	140	140		215	198		150	175	140		105	486				214	130				145
25-20.1/402	112M	x		40	25	90	140	140		215	222		150	175	140		105	507				214	130				145
32-23.1/402 ³⁾	112M	x		40	32	122	125	135		215	222		150	175	130		80	497				214	130				
32-23.1/552 ³⁾	112L	x		40	32	122	125	135		215	222		150	175	130		80	542				214	130				
32-125.1/072	80	x		50	32	80	113	113		225	160		160	140	103		118	426				225	130				100
32-125.1/112	80	x	x	50	32	80	113	113		225	160		160	140	103		118	426				225	130				100
32-125.1/152	90S	x	x	50	32	80	113	113		225	178		160	140	103		118	461				225	130				100
32-125.1/222	90L	x	x	50	32	80	113	113		225	178		160	140	103		118	461				225	130				100
32-125.1/302	100L	x		50	32	80	113	113		225	198		160	140	103		118	508				225	130				100
32-125.1/402	112M	x		50	32	80	113	113		225	222		160	140	103		118	530				225	130				100
32-125.1/552	132S	x		50	32	80	113	113	43	225	265	12		140	103	132	193	557	220	140			270	216	15	100	
32-160.1/152	90S	x		50	32	80	116	125		225	178		160	160	115		118	461				225	130				100
32-160.1/222	90L	x	x	50	32	80	116	125		225	178		160	160	115		118	461				225	130				100
32-160.1/302	100L	x	x	50	32	80	116	125		225	198		160	160	115		118	508				225	130				100
32-160.1/402	112M	x	x	50	32	80	116	125		225	222		160	160	115		118	530				225	130				100
32-160.1/552	132S	x		50	32	80	116	125	43	225	265	12		160	115	132	193	557	220	140			270	216	15	100	
32-160.1/752	132S	x	x	50	32	80	116	125	43	225	265	12		160	115	132	193	557	220	140			270	216	15	100	
32-200.1/302	100L	x		50	32	80	128	137		275	198		160	180	130		118	508				225	130				100
32-200.1/402	112M	x	x	50	32	80	128	137		275	222		160	180	130		118	530				225	130				100
32-200.1/552	132S	x	x	50	32	80	128	137	43	275	265	12		180	130	132	193	557	220	140			270	216	15	100	
32-200.1/752	132S	x		50	32	80	128	137	43	275	265	12		180	130	132	193	557	220	140			270	216	15	100	
32-200.1/1102	160M	x		50	32	80	128	137	70	275	323	14		180	130	160	200	650	300	210			320	254	21	100	
32-200.1/1502	160M	x		50	32	80	128	137	70	275	323	14		180	130	160	200	650	300	210			320	254	21	100	
32-250.1/552 ⁴⁾	132S	x		50	32	100	164	171	43	320	265	12		225	162	132	193	577	220	140			270	216	15	100	
32-250.1/752 ⁴⁾	132S	x		50	32	100	164	171	43	320	265	12		225	162	132	193	577	220	140			270	216	15	100	
32-250.1/1102 ⁴⁾	160M	x		50	32	100	164	171	70	320	323	14		225	162	160	200	670	300	210			320	254	21	100	
32-250.1/1502 ⁴⁾	160M	x		50	32	100	164	171	70	320	323	14		225	162	160	200	670	300	210			320	254	21	100	
32-125/112	80	x		50	32	80	113	113		225	160		160	140	103		118	426				225	130				100
32-125/152	90S	x	x	50	32	80	113	113		225	178		160	140	103		118	461				225	130				100
32-125/222	90L	x	x	50	32	80	113	113		225	178		160	140	103		118	461				225	130				100
32-125/302	100L	x	x	50	32	80	113	113		225	198		160	140	103		118	508				225	130				100
32-125/402	112M	x		50	32	80	113	113		225	222		160	140	103		118	530				225	130				100
32-125/552	132S	x		50	32	80	113	113	43	225	265	12		140	103	132	193	557	220	140			270	216	15	100	
32-160/222	90L	x		50	32	80	113	125		225	178		160	160	115		118	461				225	130				100
32-160/302	100L	x	x	50	32	80	113	125		225	198		160	160	115		118	508				225	130				100
32-160/402	112M	x	x	50	32	80	113	125		225	222		160	160	115		118	530				225	130				100
32-160/552	132S	x		50	32	80	113	125	43	225	265	12		160	115	132	193	557	220	140			270	216	15	100	
32-160/752	132S	x		50	32	80	113	125	43	225	265	12		160	115	132	193	557	220	140			270	216	15	100	

1) Rc = ISO 7/1; 2) EN 1092-2/DN../PN 16/21/JL1040/B 3) двухступенчатый 4) h₃ ≥ h₄
G = ISO 228/1

Etabloc G, M 32-200/... до 50-125/..., n = 2900 об/мин, n = 3500 об/мин

с опорными лапами (до типоразмера электродвигателя 112 = 4 кВт)

с опорной лапой электродвигателя

(начиная с типоразмера электродвигателя 132 = 5,5 кВт)

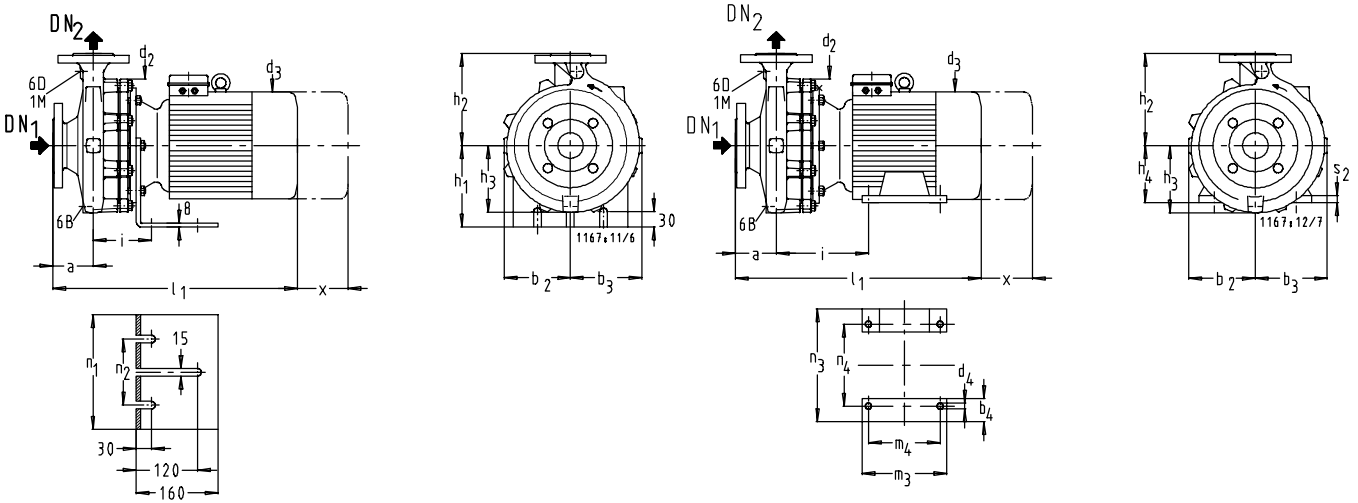

		Etabloc G, M		Etabloc SN, CN	
		Etabloc GN, MN, BN		DN ₂ 32 - DN ₂ 80	DN ₂ 100 - DN ₂ 150
1 M	Присоединение манометра	Rc 3/8 ¹⁾	Rc 1/2 ¹⁾	G 3/8 ¹⁾	G 1/2 ¹⁾
6 B	Перекачиваемая жидкость-Опорожнение	Rc 3/8 ¹⁾	Rc 1/2 ¹⁾	G 3/8 ¹⁾	G 1/2 ¹⁾
6 D	Перекачиваемая жидкость-Заполнение и опорожнение	Rc 3/8 ¹⁾	Rc 1/2 ¹⁾	G 3/8 ¹⁾	G 1/2 ¹⁾

Etabloc G, M	M	n = 2900	n = 3500	Допуски присоединительных размеров по EN 735																								
				DN ₁	DN ₂	a	b ₂ ≈	b ₃ ≈	b ₄ ≈	d ₂	d ₃ ≈	d ₄	h ₁	h ₂	h ₃	h ₄	i	l ₁ ≈	m ₃ ≈	m ₄	h ₁	h ₂	n ₃ ≈	h ₄	s ₂	x		
32-200/402	112M	x		50	32	80	132	141		275	222		160	180	133		118	530					225	130				100
32-200/552 ⁴⁾	132S	x	x	50	32	80	132	141	43	275	265	12		180	133	132	193	557	220	140					270	216	15	100
32-200/752 ⁴⁾	132S	x	x	50	32	80	132	141	43	275	265	12		180	133	160	200	650	300	210					320	254	21	100
32-200/1102	160M	x	x	50	32	80	132	141	70	275	323	14		180	133	160	200	650	300	210					320	254	21	100
32-200/1502	160M		x	50	32	80	132	141	70	275	323	14		180	133	160	200	650	300	210					320	254	21	100
32-250/752 ⁴⁾	132S	x		50	32	100	170	176	43	320	265	12		225	168	132	193	577	220	140					270	216	15	100
32-250/1102 ⁴⁾	160M	x		50	32	100	170	176	70	320	323	14		225	168	160	200	670	300	210					320	254	21	100
32-250/1502 ⁴⁾	160M	x		50	32	100	170	176	70	320	323	14		225	168	160	200	670	300	210					320	254	21	100
40-125/152	90S	x		65	40	80	113	113		225	178		160	140	103		118	461					225	130				100
40-125/222	90L	x	x	65	40	80	113	113		225	178		160	140	103		118	461					225	130				100
40-125/302	100L	x	x	65	40	80	113	113		225	198		160	140	103		118	508					225	130				100
40-125/402	112M	x	x	65	40	80	113	113		225	222		160	140	103		118	530					225	130				100
40-125/552	132S		x	65	40	80	113	113	43	225	265	12		140	103	132	193	557	220	140					270	216	15	100
40-125/752	132S		x	65	40	80	113	113	43	225	265	12		140	103	132	193	557	220	140					270	216	15	100
40-125/1102	160M		x	65	40	80	113	113	70	225	323	14		140	103	160	200	650	300	210					320	254	21	100
40-160/302	100L	x		65	40	80	115	131		225	198		160	160	118		118	508					225	130				100
40-160/402	112M	x	x	65	40	80	115	131		225	222		160	160	118		118	530					225	130				100
40-160/552	132S	x	x	65	40	80	115	131	43	225	265	12		160	118	132	193	557	220	140					270	216	15	100
40-160/752	132S	x	x	65	40	80	115	131	43	225	265	12		160	118	132	193	557	220	140					270	216	15	100
40-160/1102	160M	x	x	65	40	80	115	131	70	225	323	14		160	118	160	200	650	300	210					320	254	21	100
40-160/1502	160M		x	65	40	80	115	131	70	225	323	14		160	118	160	200	650	300	210					320	254	21	100
40-200/552 ⁴⁾	132S	x		65	40	100	140	152	43	275	265	12		180	140	132	193	577	220	140					270	216	15	100
40-200/752 ⁴⁾	132S	x	x	65	40	100	140	152	43	275	265	12		180	140	132	193	577	220	140					270	216	15	100
40-200/1102	160M	x	x	65	40	100	140	152	70	275	323	14		180	140	160	200	670	300	210					320	254	21	100
40-200/1502	160M	x	x	65	40	100	140	152	70	275	323	14		180	140	160	200	670	300	210					320	254	21	100
40-200/1852	160L		x	65	40	100	140	152	70	275	323	14		180	140	160	200	670	314	254					320	254	21	100
40-200/2202	180M		x	65	40	100	140	152	80	275	355	14		180	140	180	214	670	320	241					360	279	23	100
40-250/1102 ⁴⁾	160M	x		65	40	100	165	178	70	320	323	14		225	168	160	200	670	300	210					320	254	21	100
40-250/1502 ⁴⁾	160M	x		65	40	100	165	178	70	320	323	14		225	168	160	200	670	300	210					320	254	21	100
40-250/1852 ⁴⁾	160L	x		65	40	100	165	178	70	320	323	14		225	168	160	200	670	314	254					320	254	21	100
40-250/2202	180M	x		65	40	100	165	178	80	320	355	14		225	168	180	214	670	320	241					360	279	23	100
50-125/302	100L	x		65	50	100	113	128		225	198		160	160	112		118	528					225	130				100
50-125/402	112M	x		65	50	100	113	128		225	222		160	160	112		118	550					225	130				100
50-125/552	132S	x	x	65	50	100	113	128	43	225	265	12		160	112	132	193	577	220	140					270	216	15	100
50-125/752	132S	x	x	65	50	100	113	128	43	225	265	12		160	112	132	193	577	220	140					270	216	15	100
50-125/1102	160M	x		65	50	100	113	128	70	225	323	14		160	112	160	200	670	300	210					320	254	21	100
50-125/1502	160M		x	65	50	100	113	128	70	225	323	14		160	112	160	200	670	300	210					320	254	21	100

 1) Rc = ISO 7/1; 2) EN 1092-2/DN../PN 16/21/JL1040/B 3) двухступенчатый 4) \triangle h₃ ≥ h₄
 G = ISO 228/1

Etabloc G, M 50-160/... до 80-160/..., n = 2900 об/мин, n = 3500 об/мин

с опорными лапами (до типоразмера электродвигателя 112 = 4 кВт)
с опорной лапой электродвигателя
(начиная с типоразмера электродвигателя 132 = 5,5 кВт)

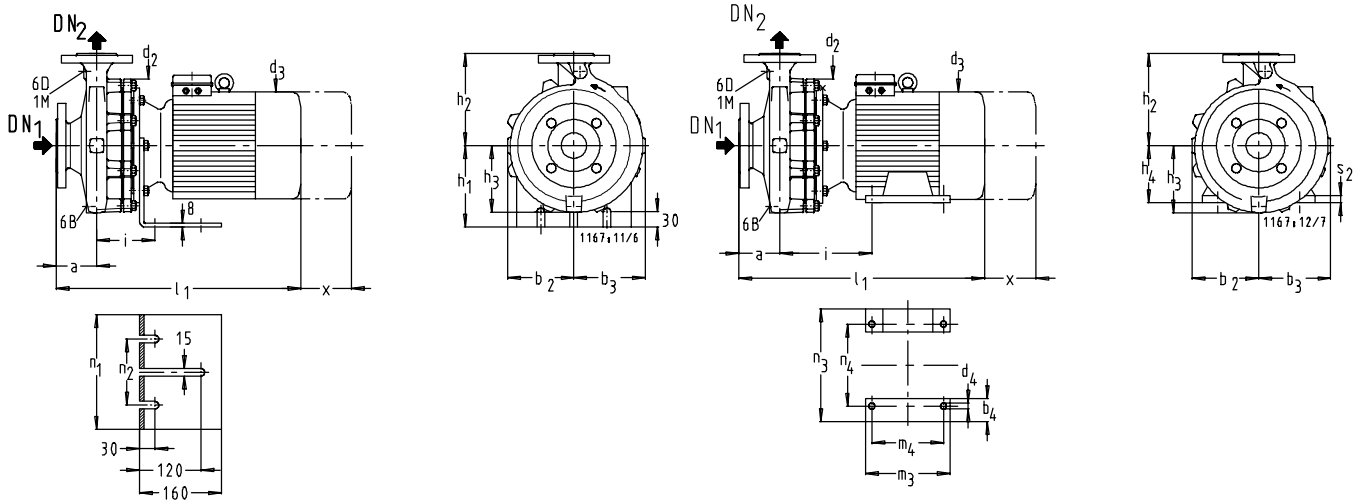

		Etabloc G, M		Etabloc SN, CN	
		Etabloc GN, MN, BN		DN ₂ 32 - DN ₂ 80	DN ₂ 100 - DN ₂ 150
1 M	Присоединение манометра	Rc 3/8 ¹⁾	Rc 1/2 ¹⁾	G 3/8 ¹⁾	G 1/2 ¹⁾
6 B	Перекачиваемая жидкость-Опорожнение	Rc 3/8 ¹⁾	Rc 1/2 ¹⁾	G 3/8 ¹⁾	G 1/2 ¹⁾
6 D	Перекачиваемая жидкость-Заполнение и опорожнение	Rc 3/8 ¹⁾	Rc 1/2 ¹⁾	G 3/8 ¹⁾	G 1/2 ¹⁾

Etabloc G, M	M	n = 2900	n = 3500	Допуски присоединительных размеров по EN 735																n ₁	h ₂	n ₃	h ₄	s ₂	x	
				DN ₁	DN ₂	a	b ₂	b ₃	b ₄	d ₂	d ₃	d ₄	h ₁	h ₂	h ₃	h ₄	i	l ₁	m ₃							m ₄
50-160/552 ⁴⁾	132S	x	x	65	50	100	126	147	43	225	265	12		180	134	132	193	577	220	140			270	216	15	100
50-160/752 ⁴⁾	132S	x	x	65	50	100	126	147	43	225	265	12		180	134	132	193	577	220	140			270	216	15	100
50-160/1102	160M	x	x	65	50	100	126	147	70	225	323	14		180	134	160	200	670	300	210			320	254	21	100
50-160/1502	160M	x	x	65	50	100	126	147	70	225	323	14		180	134	160	200	670	300	210			320	254	21	100
50-160/1852	160L		x	65	50	100	126	147	70	225	323	14		180	134	160	200	670	314	254			320	254	21	100
50-160/2202	180M		x	65	50	100	126	147	80	225	355	14		180	134	180	214	670	320	241			360	279	23	100
50-200/1102	160M	x	x	65	50	100	145	165	70	275	323	14		200	152	160	200	670	300	210			320	254	21	100
50-200/1502	160M	x	x	65	50	100	145	165	70	275	323	14		200	152	160	200	670	300	210			320	254	21	100
50-200/1852	160L	x	x	65	50	100	145	165	70	275	323	14		200	152	160	200	670	314	254			320	254	21	100
50-200/2202	180M	x	x	65	50	100	145	165	80	275	355	14		200	152	180	214	670	320	241			360	279	23	100
50-250/1502 ⁴⁾	160M	x		65	50	100	168	184	70	320	323	14		225	172	160	200	670	300	210			320	254	21	100
50-250/1852 ⁴⁾	160L	x		65	50	100	168	184	70	320	323	14		225	172	160	200	670	314	254			320	254	21	100
50-250/2202	180M	x		65	50	100	168	184	80	320	355	14		225	172	180	214	670	320	241			360	279	23	100
65-125/402	112M	x		80	65	100	120	148		225	222		160	180	132		118	550			225	130				100
65-125/552 ⁴⁾	132S	x	x	80	65	100	120	148	43	225	265	12		180	132	132	193	577	220	140			270	216	15	100
65-125/752 ⁴⁾	132S	x	x	80	65	100	120	148	43	225	265	12		180	132	132	193	577	220	140			270	216	15	100
65-125/1102	160M	x	x	80	65	100	120	148	70	225	323	14		180	132	160	200	670	300	210			320	254	21	100
65-125/1502	160M		x	80	65	100	120	148	70	225	323	14		180	132	160	200	670	300	210			320	254	21	100
65-160/752 ⁴⁾	132S	x		80	65	100	130	158	43	225	265	12		200	140	132	193	577	220	140			270	216	15	100
65-160/1102	160M	x	x	80	65	100	130	158	70	225	323	14		200	140	160	200	670	300	210			320	254	21	100
65-160/1502	160M	x	x	80	65	100	130	158	70	225	323	14		200	140	160	200	670	300	210			320	254	21	100
65-160/1852	160L		x	80	65	100	130	158	70	225	323	14		200	140	160	200	670	314	254			320	254	21	100
65-160/2202	180M		x	80	65	100	130	158	80	225	355	14		200	140	180	214	670	320	241			360	279	23	100
65-200/1502 ⁴⁾	160M	x		80	65	100	154	177	70	275	323	14		225	161	160	200	670	300	210			320	254	21	140
65-200/1852 ⁴⁾	160L	x	x	80	65	100	154	177	70	275	323	14		225	161	160	200	670	314	254			320	254	21	140
65-200/2202	180M	x	x	80	65	100	154	177	80	275	355	14		225	161	180	214	670	320	241			360	279	23	140
80-160/1102 ⁴⁾	160M	x		100	80	125	153	192	70	225	323	14		225	168	160	200	695	300	210			320	254	21	140
80-160/1502 ⁴⁾	160M	x		100	80	125	153	192	70	225	323	14		225	168	160	200	695	300	210			320	254	21	140
80-160/1852 ⁴⁾	160L	x		100	80	125	153	192	70	225	323	14		225	168	160	200	695	314	254			320	254	21	140
80-160/2202	180M	x	x	100	80	125	153	192	80	225	355	14		225	168	180	214	695	320	241			360	279	23	140

1) Rc = ISO 7/1; 2) EN 1092-2/DN../PN 16/21/JL1040/B 3) двухступенчатый 4) h₃ ≥ h₄
G = ISO 228/1

Etabloc G, M 25-20,1/... до 40-125/..., n = 1450 об/мин, n = 1750 об/мин

с опорными лапами (до типоразмера электродвигателя 112 = 4 кВт)
с опорной лапой электродвигателя
(начиная с типоразмера электродвигателя 132 = 5,5 кВт)

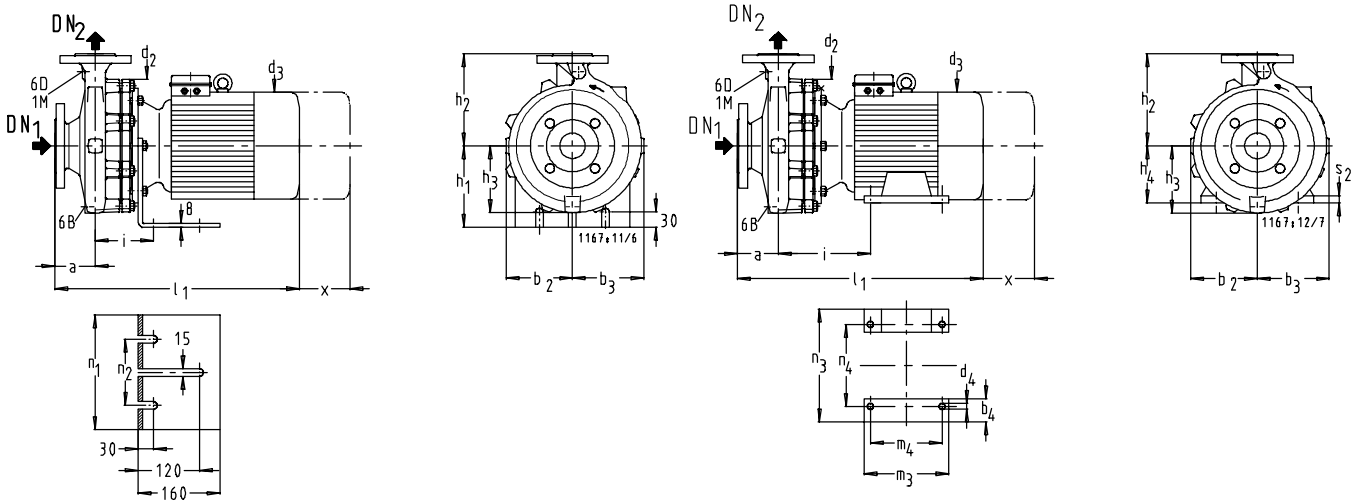

		Etabloc G, M		Etabloc SN, CN	
		Etabloc GN, MN, BN		DN ₂ 32 - DN ₂ 80	DN ₂ 100 - DN ₂ 150
1 M	Присоединение манометра	Rc 3/8 ¹⁾	Rc 1/2 ¹⁾	G 3/8 ¹⁾	G 1/2 ¹⁾
6 B	Перекачиваемая жидкость-Опорожнение	Rc 3/8 ¹⁾	Rc 1/2 ¹⁾	G 3/8 ¹⁾	G 1/2 ¹⁾
6 D	Перекачиваемая жидкость-Заполнение и опорожнение	Rc 3/8 ¹⁾	Rc 1/2 ¹⁾	G 3/8 ¹⁾	G 1/2 ¹⁾

Etabloc G, M	M	n = 1450	n = 1750	Допуски присоединительных размеров по EN 735																						
				DN ₁	DN ₂	a	b ₂ ≈	b ₃ ≈	b ₄ ≈	d ₂	d ₃ ≈	d ₄	h ₁	h ₂	h ₃	h ₄	i	l ₁ ≈	m ₃ ≈	m ₄	h ₁	h ₂	n ₃ ≈	h ₄	s ₂	x
25-20.1/034	71	x		40	25	90	140	140		215	138		150	175	140		105	405			214	130				145
32-125.1/024	71	x	x	50	32	80	113	113		225	143		160	140	103		118	409			225	130				100
32-125.1/034	71	x	x	50	32	80	113	113		225	143		160	140	103		118	409			225	130				100
32-125.1/054	80	x	x	50	32	80	113	113		225	160		160	140	103		118	426			225	130				100
32-160.1/034	71	x	x	50	32	80	116	125		225	143		160	160	115		118	409			225	130				100
32-160.1/054	80	x	x	50	32	80	116	125		225	160		160	160	115		118	426			225	130				100
32-160.1/074	80		x	50	32	80	116	125		225	160		160	160	115		118	426			225	130				100
32-160.1/114	90S		x	50	32	80	116	125		225	178		160	160	115		118	461			225	130				100
32-200.1/054	80	x	x	50	32	80	128	137		275	160		160	180	130		118	426			225	130				100
32-200.1/074	80	x	x	50	32	80	128	137		275	160		160	180	130		118	426			225	130				100
32-200.1/114	90S		x	50	32	80	128	137		275	178		160	180	130		118	461			225	130				100
32-200.1/154	90L		x	50	32	80	128	137		275	178		160	180	130		118	461			225	130				100
32-200.1/224	100L		x	50	32	80	128	137		275	198		160	180	130		118	508			225	130				100
32-250.1/074 ³⁾	80	x		50	32	100	164	171		320	160		160	225	162		118	446			225	130				100
32-250.1/114 ³⁾	90S	x	x	50	32	100	164	171		320	178		160	225	162		118	481			225	130				100
32-250.1/154 ³⁾	90L	x	x	50	32	100	164	171		320	178		160	225	162		118	481			225	130				100
32-250.1/224 ³⁾	100L	x	x	50	32	100	164	171		320	198		160	225	162		118	528			225	130				100
32-250.1/304 ³⁾	100L		x	50	32	100	164	171		320	198		160	225	162		118	528			225	130				100
32-125/034	71	x	x	50	32	80	113	113		225	143		160	140	103		118	409			225	130				100
32-125/054	80	x	x	50	32	80	113	113		225	160		160	140	103		118	426			225	130				100
32-125/074	80		x	50	32	80	113	113		225	160		160	140	103		118	426			225	130				100
32-160/054	80	x	x	50	32	80	113	125		225	160		160	160	115		118	426			225	130				100
32-160/074	80		x	50	32	80	113	125		225	160		160	160	115		118	426			225	130				100
32-160/114	90S		x	50	32	80	113	125		225	178		160	160	115		118	461			225	130				100
32-200/054	80	x		50	32	80	132	141		275	160		160	180	133		118	426			225	130				100
32-200/074	80	x	x	50	32	80	132	141		275	160		160	180	133		118	426			225	130				100
32-200/114	90S	x	x	50	32	80	132	141		275	178		160	180	133		118	461			225	130				100
32-200/154	90L		x	50	32	80	132	141		275	178		160	180	133		118	461			225	130				100
32-200/224	100L		x	50	32	80	132	141		275	198		160	180	133		118	508			225	130				100
32-250/114 ³⁾	90S	x		50	32	100	170	176		320	178		160	225	168		118	481			225	130				100
32-250/154 ³⁾	90L	x		50	32	100	170	176		320	178		160	225	168		118	481			225	130				100
32-250/224 ³⁾	100L	x	x	50	32	100	170	176		320	198		160	225	168		118	528			225	130				100
32-250/304 ³⁾	100L		x	50	32	100	170	176		320	198		160	225	168		118	528			225	130				100
32-250/404 ³⁾	112M		x	50	32	100	170	176		320	222		160	225	168		118	550			225	130				100
40-125/024	71	x		65	40	80	113	113		225	143		160	140	103		118	409			225	130				100
40-125/034	71	x		65	40	80	113	113		225	143		160	140	103		118	409			225	130				100
40-125/054	80	x	x	65	40	80	113	113		225	160		160	140	103		118	426			225	130				100
40-125/074	80		x	65	40	80	113	113		225	160		160	140	103		118	426			225	130				100
40-125/114	90S		x	65	40	80	113	113		225	178		160	140	103		118	461			225	130				100

1) Rc = ISO 7/1; G = ISO 228/1
2) ≤ DN 150 = EN 1092-2/DN.../PN 16/21/JL1040/B
DN 200 = EN 1092-2/DN 200/PN 10/21/JL1040/B

3) Δ h₃ ≥ h₁ / h₃ ≥ h₄

Etabloc G, M 40-160/... до 50-250/..., n = 1450 об/мин, n = 1750 об/мин

с опорными лапами (до типоразмера электродвигателя 112 = 4 кВт)
с опорной лапой электродвигателя
(начиная с типоразмера электродвигателя 132 = 5,5 кВт)

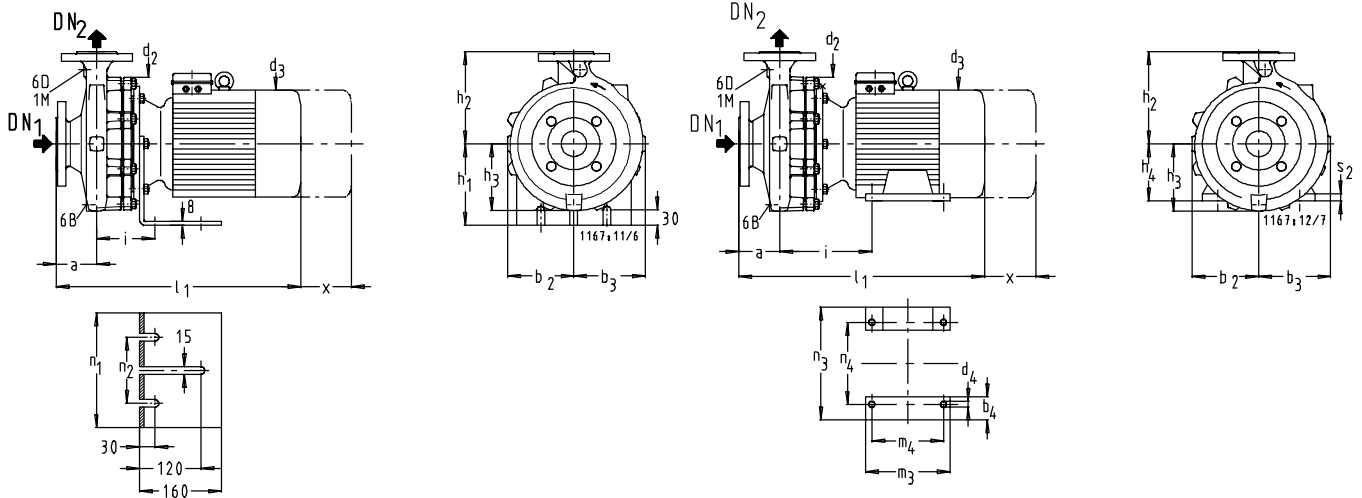

		Etabloc G, M		Etabloc SN, CN	
		Etabloc GN, MN, BN			
		DN ₂ 32 - DN ₂ 80	DN ₂ 100	DN ₂ 32 - DN ₂ 80	DN ₂ 100 - DN ₂ 150
1 M	Присоединение манометра	Rc 3/8 ¹⁾	Rc 1/2 ¹⁾	G 3/8 ¹⁾	G 1/2 ¹⁾
6 B	Перекачиваемая жидкость-Опорожнение	Rc 3/8 ¹⁾	Rc 1/2 ¹⁾	G 3/8 ¹⁾	G 1/2 ¹⁾
6 D	Перекачиваемая жидкость-Заполнение и опорожнение	Rc 3/8 ¹⁾	Rc 1/2 ¹⁾	G 3/8 ¹⁾	G 1/2 ¹⁾

Etabloc G, M		n = 1450	n = 1750	Допуски присоединительных размеров по EN 735																					
М	М			DN 1 2)	DN 2 2)	a	b ₂ ≈	b ₃ ≈	b ₄ ≈	d ₂	d ₃ ≈	d ₄	h ₁	h ₂	h ₃	h ₄	i	l ₁ ≈	m ₃ ≈	m ₄	h ₁	h ₂	n ₃ ≈	h ₄	s ₂
40-160/054	80	x		65	40	80	115	131	225	160		160	160	118	118	426				225	130				100
40-160/074	80	x	x	65	40	80	115	131	225	160		160	160	118	118	426				225	130				100
40-160/114	90S	x	x	65	40	80	115	131	225	178		160	160	118	118	461				225	130				100
40-160/154	90L		x	65	40	80	115	131	225	178		160	160	118	118	461				225	130				100
40-160/224	100L		x	65	40	80	115	131	225	198		160	160	118	118	508				225	130				100
40-200/074	80	x		65	40	100	140	152	275	160		160	180	140	118	446				225	130				100
40-200/114	90S	x		65	40	100	140	152	275	178		160	180	140	118	481				225	130				100
40-200/154	90L	x	x	65	40	100	140	152	275	178		160	180	140	118	481				225	130				100
40-200/224	100L		x	65	40	100	140	152	275	198		160	180	140	118	528				225	130				100
40-200/304	100L		x	65	40	100	140	152	275	198		160	180	140	118	528				225	130				100
40-250/114 ³⁾	90S	x		65	40	100	165	178	320	178		160	225	168	118	481				225	130				100
40-250/154 ³⁾	90L	x		65	40	100	165	178	320	178		160	225	168	118	481				225	130				100
40-250/224 ³⁾	100L	x	x	65	40	100	165	178	320	198		160	225	168	118	528				225	130				100
40-250/304 ³⁾	100L	x	x	65	40	100	165	178	320	198		160	225	168	118	528				225	130				100
40-250/404 ³⁾	112M		x	65	40	100	165	178	320	222		160	225	168	118	550				225	130				100
40-315/224 ³⁾	100L	x		65	40	125	194	203	400	198		180	250	196	142	576				260	180				100
40-315/304 ³⁾	100L	x		65	40	125	194	203	400	198		180	250	196	142	576				260	180				100
40-315/404 ³⁾	112M	x	x	65	40	125	194	203	400	222		180	250	196	142	597				260	180				100
40-315/554 ³⁾	132S	x	x	65	40	125	194	203	43	400	265	12	250	196	132	216	625	220	140			270	216	15	100
40-315/754 ³⁾	132M		x	65	40	125	194	203	43	400	265	12	250	196	132	216	625	240	178			270	216	15	100
40-315/31104 ³⁾	160M		x	65	40	125	194	203	70	400	323	14	250	196	160	223	718	300	210			320	254	21	100
50-125/054	80	x		65	50	100	113	128	225	160		160	160	112	118	446				225	130				100
50-125/074	80	x	x	65	50	100	113	128	225	160		160	160	112	118	446				225	130				100
50-125/114	90S	x	x	65	50	100	113	128	225	178		160	160	112	118	481				225	130				100
50-125/154	90L		x	65	50	100	113	128	225	178		160	160	112	118	481				225	130				100
50-160/074	80	x		65	50	100	126	147	225	160		160	180	134	118	446				225	130				100
50-160/114	90S	x	x	65	50	100	126	147	225	178		160	180	134	118	481				225	130				100
50-160/154	90L	x	x	65	50	100	126	147	225	178		160	180	134	118	481				225	130				100
50-160/224	100L		x	65	50	100	126	147	225	198		160	180	134	118	528				225	130				100
50-160/304	100L		x	65	50	100	126	147	225	198		160	180	134	118	528				225	130				100
50-200/154	90L	x		65	50	100	145	165	275	178		160	200	152	118	481				225	130				100
50-200/224	100L	x	x	65	50	100	145	165	275	198		160	200	152	118	528				225	130				100
50-200/304	100L	x	x	65	50	100	145	165	275	198		160	200	152	118	528				225	130				100
50-200/404	112M		x	65	50	100	145	165	275	222		160	200	152	118	550				225	130				100
50-250/224 ³⁾	100L	x	x	65	50	100	168	184	320	198		160	225	172	118	528				225	130				100
50-250/304 ³⁾	100L	x		65	50	100	168	184	320	198		160	225	172	118	528				225	130				100
50-250/404 ³⁾	112M	x	x	65	50	100	168	184	320	222		160	225	172	118	550				225	130				100

1) Rc = ISO 7/1;
G = ISO 228/1

2) ≤ DN 150 = EN 1092-2/DN.../PN 16/21/JL1040/B
DN 200 = EN 1092-2/DN 200/PN 10/21/JL1040/B

3) h₃ ≥ h₁ / h₃ ≥ h₄

Etabloc G, M 50-315/... до 80-200/..., n = 1450 об/мин, n = 1750 об/мин

с опорными лапами (до типоразмера электродвигателя 112 = 4 кВт)
 с опорной лапой электродвигателя
 (начиная с типоразмера электродвигателя 132 = 5,5 кВт)

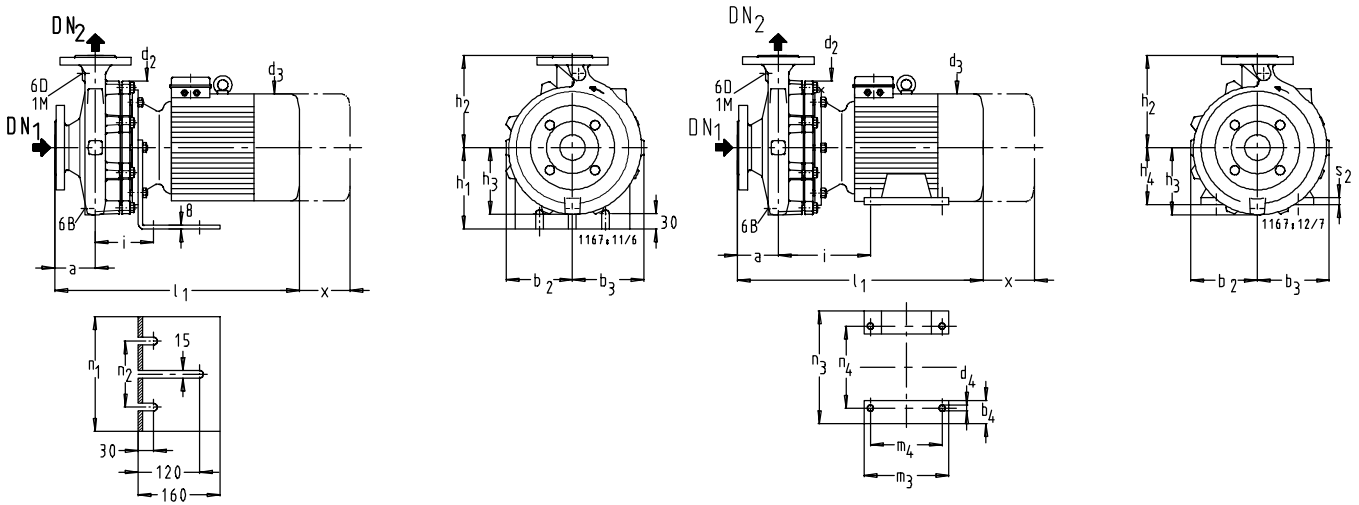

		Etabloc G, M		Etabloc SN, CN	
		Etabloc GN, MN, BN		Etabloc SN, CN	
		DN ₂ 32 - DN ₂ 80	DN ₂ 100	DN ₂ 32 - DN ₂ 80	DN ₂ 100 - DN ₂ 150
1 M	Присоединение манометра	Rc 3/8 ¹⁾	Rc 1/2 ¹⁾	G 3/8 ¹⁾	G 1/2 ¹⁾
6 B	Перекачиваемая жидкость-Опорожнение	Rc 3/8 ¹⁾	Rc 1/2 ¹⁾	G 3/8 ¹⁾	G 1/2 ¹⁾
6 D	Перекачиваемая жидкость-Заполнение и опорожнение	Rc 3/8 ¹⁾	Rc 1/2 ¹⁾	G 3/8 ¹⁾	G 1/2 ¹⁾

Etabloc G, M		n = 1450		n = 1750		Допуски присоединительных размеров по EN 735																					
	Ⓜ	DN ₁	DN ₂	a	b ₂ ≈	b ₃ ≈	b ₄ ≈	d ₂	d ₃ ≈	d ₄	h ₁	h ₂	h ₃	h ₄	i	l ₁ ≈	m ₃ ≈	m ₄	h ₁	h ₂	n ₃ ≈	n ₄	s ₂	x			
50-315/304 ³⁾	100L	x	65	50	125	200	216		400	198	180	280	204		142	576				260	180				100		
50-315/404 ³⁾	112M	x	65	50	125	200	216		400	222	180	280	204		142	597				260	180				100		
50-315/554 ³⁾	132S	x	65	50	125	200	216	43	400	265	12	280	204	132	216	625	240	140				270	216	15	100		
50-315/754 ³⁾	132M	x	65	50	125	200	216	43	400	265	12	280	204	132	216	625	240	178				270	216	15	100		
50-315/1104 ³⁾	160M	x	65	50	125	200	216	70	400	323	14	280	204	160	223	718	300	210				320	254	21	100		
50-315/1504 ³⁾	160L	x	65	50	125	200	216	70	400	323	14	280	204	160	223	718	314	254				320	254	21	100		
65-125/054	80	x	80	65	100	120	148		225	160	160	180	132		118	446				225	130				100		
65-125/074	80	x	80	65	100	120	148		225	160	160	180	132		118	446				225	130				100		
65-125/114	90S	x	80	65	100	120	148		225	178	160	180	132		118	481				225	130				100		
65-125/154	90L	x	80	65	100	120	148		225	178	160	180	132		118	481				225	130				100		
65-125/224	100L	x	80	65	100	120	148		225	198	160	180	132		118	528				225	130				100		
65-160/114	90S	x	80	65	100	130	158		225	178	160	200	140		118	481				225	130				100		
65-160/154	90L	x	80	65	100	130	158		225	178	160	200	140		118	481				225	130				100		
65-160/224	100L	x	80	65	100	130	158		225	198	160	200	140		118	528				225	130				100		
65-160/304	100L	x	80	65	100	130	158		225	198	160	200	140		118	528				225	130				100		
65-160/404	112M	x	80	65	100	130	158		225	222	160	200	140		118	550				225	130				100		
65-200/224 ³⁾	100L	x	80	65	100	154	177		275	198	160	225	161		118	528				225	130				140		
65-200/304 ³⁾	100L	x	80	65	100	154	177		275	198	160	225	161		118	528				225	130				140		
65-200/404 ³⁾	112M	x	80	65	100	154	177		275	222	160	225	161		118	550				225	130				140		
65-250/304 ³⁾	100L	x	80	65	100	180	200		320	198	180	250	186		142	551				260	180				140		
65-250/404 ³⁾	112M	x	80	65	100	180	200		320	222	180	250	186		142	572				260	180				140		
65-250/554 ³⁾	132S	x	80	65	100	180	200	43	320	265	12	250	186	132	216	600	220	140				270	216	15	140		
65-250/754 ³⁾	132M	x	80	65	100	180	200	43	320	265	12	250	186	132	216	600	240	178				270	216	15	140		
65-250/1104 ³⁾	160M	x	80	65	100	180	200	70	320	323	14	250	186	160	223	693	300	210				320	254	21	140		
65-315/554 ³⁾	132S	x	80	65	125	208	229	43	400	265	12	280	214	132	216	625	220	140				270	216	15	140		
65-315/754 ³⁾	132M	x	80	65	125	208	229	43	400	265	12	280	214	132	216	625	240	178				270	216	15	140		
65-315/1104 ³⁾	160M	x	80	65	125	208	229	70	400	323	14	280	214	160	223	718	300	210				320	254	21	140		
65-315/1504 ³⁾	160L	x	80	65	125	208	229	70	400	323	14	280	214	160	223	718	314	254				320	254	21	140		
65-315/1854 ³⁾	180M	x	80	65	125	208	229	80	400	360	14	280	214	180	237	782	320	241				360	279	23	140		
65-315/2204 ³⁾	180L	x	80	65	125	208	229	80	400	360	14	280	214	180	237	819	358	279				360	279	23	140		
80-160/154 ³⁾	90L	x	100	80	125	153	192		225	178	160	225	168		118	506				225	130				140		
80-160/224 ³⁾	100L	x	100	80	125	153	192		225	198	160	225	168		118	553				225	130				140		
80-160/304 ³⁾	100L	x	100	80	125	153	192		225	198	160	225	168		118	553				225	130				140		
80-160/404 ³⁾	112M	x	100	80	125	153	192		225	222	160	225	168		118	575				225	130				140		
80-200/224	100L	x	100	80	125	161	189		275	198	180	250	170		142	576				260	180				140		
80-200/304	100L	x	100	80	125	161	189		275	198	180	250	170		142	576				260	180				140		
80-200/404	112M	x	100	80	125	161	189		275	222	180	250	170		142	597				260	180				140		
80-200/554 ³⁾	132S	x	100	80	125	161	189	43	275	265	12	250	170	132	216	625	220	140				270	216	15	140		
80-200/754 ³⁾	132M	x	100	80	125	161	189	43	275	265	12	250	170	132	216	625	240	178				270	216	15	140		
80-200/1104 ³⁾	160M	x	100	80	125	161	189	70	275	323	14	250	170	160	223	718	300	210				320	254	21	140		

1) Rc = ISO 7/1; 2) ≤ DN 150 = EN 1092-2/DN.../PN 16/21/JL1040/B
 G = ISO 228/1 DN 200 = EN 1092-2/DN 200/PN 10/21/JL1040/B
 3) Δ h₃ ≥ h₁ / h₃ ≥ h₄

Etabloc G, M 80-250/... до 150-250/..., n = 1450 об/мин, n = 1750 об/мин

с опорными лапами (до типоразмера электродвигателя 112 = 4 кВт)
с опорной лапой электродвигателя
(начиная с типоразмера электродвигателя 132 = 5,5 кВт)

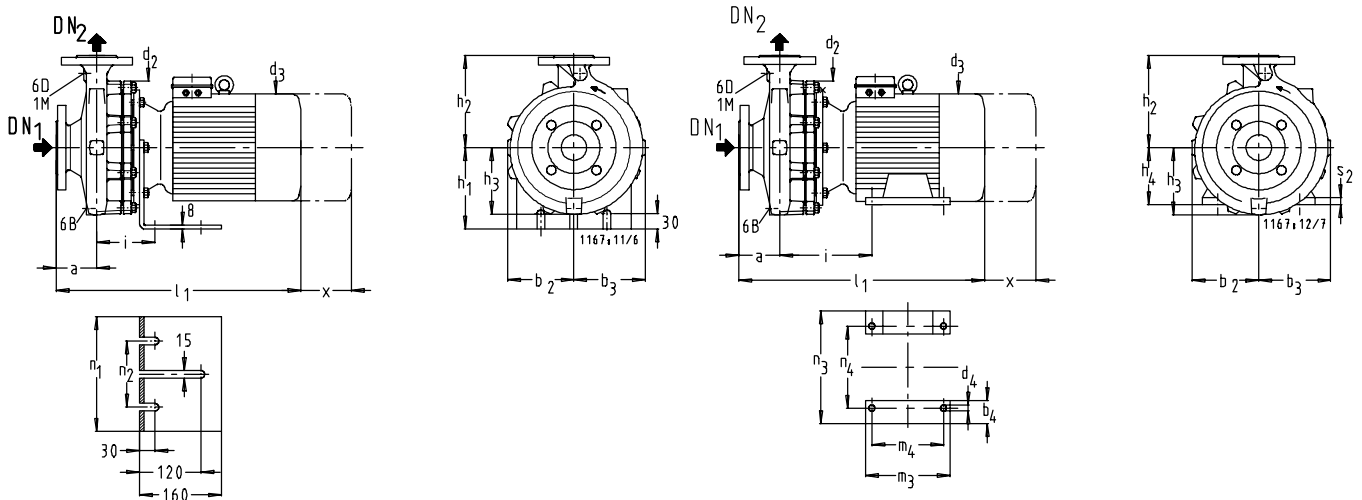

		Etabloc G, M		Etabloc SN, CN			
		Etabloc GN, MN, BN					
		DN ₂ 32 - DN ₂ 80	DN ₂ 100	DN ₂ 32 - DN ₂ 80	DN ₂ 100 - DN ₂ 150		
1 M	Присоединение манометра	Rc 3/8 ¹⁾	Rc 1/2 ¹⁾	G 3/8 ¹⁾	G 1/2 ¹⁾		
6 B	Перекачиваемая жидкость-Опорожнение	Rc 3/8 ¹⁾	Rc 1/2 ¹⁾	G 3/8 ¹⁾	G 1/2 ¹⁾		
6 D	Перекачиваемая жидкость-Заполнение и опорожнение	Rc 3/8 ¹⁾	Rc 1/2 ¹⁾	G 3/8 ¹⁾	G 1/2 ¹⁾		

Etabloc G, M		Ⓜ	n = 1450	n = 1750	Допуски присоединительных размеров по EN 735																								
					DN ₁ 2)	DN ₂ 2)	a	b ₂ ≈	b ₃ ≈	b ₄ ≈	d ₂	d ₃ ≈	d ₄	h ₁	h ₂	h ₃	h ₄	i	l ₁ ≈	m ₃ ≈	m ₄	h ₁	h ₂	n ₃ ≈	h ₄	s ₂	x		
80-250/404 ³⁾	112M	x			100	80	125	184	210		320	265	12	180	280	195	142	597	220	140			260	180					
80-250/554 ³⁾	132S	x			100	80	125	184	210	43	320	265	12	180	280	195	132	216	625	240	178					270	216	15	140
80-250/754 ³⁾	132M	x	x		100	80	125	184	210	43	320	265	12	280	195	132	216	625	240	178						270	216	15	140
80-250/1104 ³⁾	160M	x	x		100	80	125	184	210	70	320	323	14	280	195	160	223	718	300	210						320	254	21	140
80-250/1504 ³⁾	160L	x		x	100	80	125	184	210	70	320	323	14	280	195	160	223	718	314	254						320	254	21	140
80-250/1854 ³⁾	180M	x		x	100	80	125	184	210	80	320	360	14	280	195	180	237	782	320	241						360	279	23	140
80-315/754 ³⁾	132M	x			100	80	125	220	244	43	400	265	12	315	228	132	216	625	240	178						270	216	15	140
80-315/1104 ³⁾	160M	x			100	80	125	220	244	70	400	323	14	315	228	160	223	718	300	210						320	254	21	140
80-315/1504 ³⁾	160L	x	x		100	80	125	220	244	70	400	323	14	315	228	160	223	718	314	254						320	254	21	140
80-315/1854 ³⁾	180M	x	x		100	80	125	220	244	80	400	360	14	315	228	180	237	782	320	241						360	279	23	140
80-315/2204 ⁴⁾	180L	x	x		100	80	125	220	244	80	400	360	14	315	228	180	237	819	358	279						360	279	23	140
100-160/304 ³⁾	100L	x			125	100	125	178	225		275	198		180	280	196		142	576			260	180						140
100-160/404 ³⁾	112M	x			125	100	125	178	225		275	222		180	280	196		142	597			260	180						140
100-160/554 ³⁾	132S	x	x		125	100	125	178	225	43	275	265	12		280	196	132	216	625	220	140					270	216	15	140
100-160/754 ³⁾	132M	x		x	125	100	125	178	225	43	275	265	12		280	196	132	216	625	240	178					270	216	15	140
100-200/404 ³⁾	112M	x			125	100	125	173	213		275	222		180	280	190		142	597			260	180						140
100-200/554 ³⁾	132S	x			125	100	125	173	213	43	275	265	12		280	190	132	216	625	220	140					270	216	15	140
100-200/754 ³⁾	132M	x	x		125	100	125	173	213	43	275	265	12		280	190	132	216	625	240	178					270	216	15	140
100-200/1104 ³⁾	160M	x		x	125	100	125	173	213	70	275	323	14		280	190	160	223	718	300	210					320	254	21	140
100-200/1504 ³⁾	160L	x		x	125	100	125	173	213	70	275	323	14		280	190	160	223	718	314	254					320	254	21	140
100-250/754 ³⁾	132M	x			125	100	140	190	220	43	320	265	12		280	201	132	216	640	240	178					270	216	15	140
100-250/1104 ³⁾	160M	x	x		125	100	140	190	220	70	320	323	14		280	201	160	223	733	300	210					320	254	21	140
100-250/1504 ³⁾	160L	x	x		125	100	140	190	220	70	320	323	14		280	201	160	223	733	314	254					320	254	21	140
100-250/1854 ³⁾	180M	x			125	100	140	190	220	80	320	360	14		280	201	180	237	797	320	241					360	279	23	140
100-250/2204 ³⁾	180L	x		x	125	100	140	190	220	80	320	360	14		280	201	180	237	834	358	279					360	279	23	140
100-315/1504 ³⁾	160L	x			125	100	140	225	255	70	400	323	14		315	237	160	223	733	314	254					320	254	21	140
100-315/1854 ³⁾	180M	x	x		125	100	140	225	255	80	400	360	14		315	237	180	237	797	320	241					360	279	23	140
100-315/2204 ³⁾	180L	x	x		125	100	140	225	255	80	400	360	14		315	237	180	237	834	358	279					360	279	23	140
125-200/754 ³⁾	132M	x			150	125	140	195	244	43	275	265	12		315	216	132	216	640	240	178					270	216	15	140
125-200/1104 ³⁾	160M	x	x		150	125	140	195	244	70	275	323	14		315	216	160	223	733	300	210					320	254	21	140
125-200/1504 ³⁾	160L	x	x		150	125	140	195	244	70	275	323	14		315	216	160	223	733	314	254					320	254	21	140
125-200/1854 ³⁾	180M	x		x	150	125	140	195	244	80	275	360	14		315	216	180	237	797	320	241					360	279	23	140
125-200/2204 ³⁾	180L	x		x	150	125	140	195	244	80	275	360	14		315	216	180	237	834	358	279					360	279	23	140
125-250/1104 ³⁾	160M	x			150	125	140	226	275	70	320	323	14		315	245	160	223	733	300	210					320	254	21	140
125-250/1504 ³⁾	160L	x	x		150	125	140	226	275	70	320	323	14		315	245	160	223	733	314	254					320	254	21	140
125-250/1854 ³⁾	180M	x	x		150	125	140	226	275	80	320	360	14		315	245	180	237	797	320	241					360	279	23	140
125-250/2204 ³⁾	180L	x	x		150	125	140	226	275	80	320	360	14		315	245	180	237	834	358	279					360	279	23	140
150-200/754 ³⁾	132M	x			200	150	160	238	315	43	275	265	12		400	275	132	216	660	240	178					270	216	15	140
150-200/1104 ³⁾	160M	x			200	150	160	238	315	70	275	323	14		400	275	160	223	753	300	210					320	254	21	140
150-200/1504 ³⁾	160L	x	x		200	150	160	238	315	70	275	323	14		400	275	160	223	753	314	254					320	254	21	140
150-200/1854 ³⁾	180M	x			200	150	160	238	315	80	275	360	14		400	275	180	237	817	320	241					360	279	23	140
150-200/2204 ³⁾	180L	x		x	200	150	160	238	315	80	275	360	14		400	275	180	237	854	358	279					360	279	23	140
150-250/1504 ³⁾	160L	x			200	150	160	228	298	70	320	323	14		400	260	160	223	753	314	254					320	254	21	140
150-250/1854 ³⁾	180M	x			200	150	160	228	298	80	320	360	14		400	260	180	237	817	320	241					360	279	23	140
150-250/2204 ³⁾	180L	x	x		200	150	160	228	298	80	320	360	14		400	260	180	237	854	358	279					360	279	23	140

1) Rc = ISO 7/1; G = ISO 228/1
2) ≤ DN 150 = EN 1092-2/DN../PN 16/21/JL1040/B
DN 200 = EN 1092-2/DN 200/PN 10/21/JL1040/B

3) h₃ ≥ h₁ / h₃ ≥ h₄

Etabloc G, M 32-125,1/... до 32-250/..., n = 2900 об/мин, n = 3500 об/мин

с опорными лапами (до типоразмера электродвигателя 112 = 4 кВт)

с опорной лапой электродвигателя

(начиная с типоразмера электродвигателя 132 = 5,5 кВт)

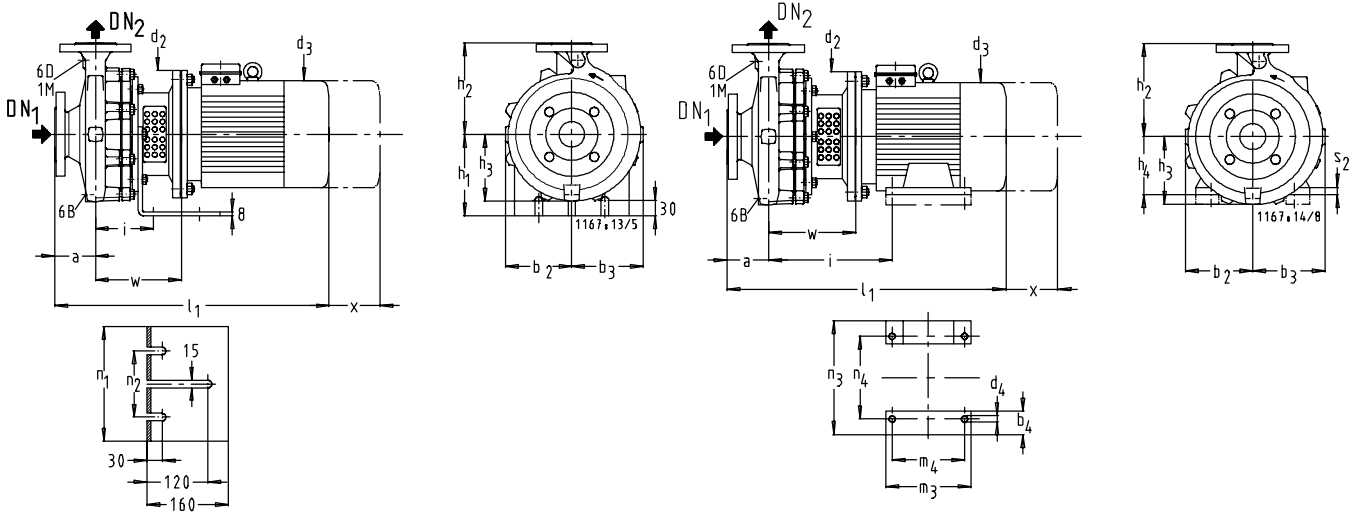

		Etabloc G, M			
		Etabloc GN, MN, BN		Etabloc SN, CN	
		DN ₂ 32 - DN ₂ 80	DN ₂ 100	DN ₂ 32 - DN ₂ 80	DN ₂ 100 - DN ₂ 150
1 M	Присоединение манометра	Rc 3/8 ¹⁾	Rc 1/2 ¹⁾	G 3/8 ¹⁾	G 1/2 ¹⁾
6 B	Перекачиваемая жидкость-Опорожнение	Rc 3/8 ¹⁾	Rc 1/2 ¹⁾	G 3/8 ¹⁾	G 1/2 ¹⁾
6 D	Перекачиваемая жидкость-Заполнение и опорожнение	Rc 3/8 ¹⁾	Rc 1/2 ¹⁾	G 3/8 ¹⁾	G 1/2 ¹⁾

MM

Etabloc GN, MN	M	n = 2900	n = 3500	Допуски присоединительных размеров по EN 735																							
				DN ₂ 1	DN ₂ 2	a	b ₂ ≈	b ₃ ≈	b ₄ ≈	d ₂	d ₃ ≈	d ₄	h ₁	h ₂	h ₃	h ₄	i	l ₁ ≈	m ₃ ≈	m ₄	n ₁	n ₂	n ₃ ≈	n ₄	s ₂	w	x
32-125.1/072	80	x		50	32	80	113	113		200	162		160	140	103		118	491			225	130				156	100
32-125.1/112	80	x	x	50	32	80	113	113		200	162		160	140	103		118	491			225	130				156	100
32-125.1/152	90S	x	x	50	32	80	113	113		200	190		160	140	103		118	518			225	130				156	100
32-125.1/222	90L	x	x	50	32	80	113	113		200	190		160	140	103		118	525			225	130				156	100
32-125.1/302	100L	x	x	50	32	80	113	113		250	213		160	140	103		118	563			225	130				170	100
32-125.1/402	112M	x	x	50	32	80	113	113		250	234		160	140	103		118	584			225	130				170	100
32-125.1/552 ³⁾	132S	x	x	50	32	80	113	113	55	300	266	12		140	103	132	282	672	220	140			270	216	15	193	100
32-160.1/152	90S	x		50	32	80	116	125		200	190		160	160	115		118	518			225	130				156	100
32-160.1/222	90L	x	x	50	32	80	116	125		200	190		160	160	115		118	525			225	130				156	100
32-160.1/302	100L	x	x	50	32	80	116	125		250	213		160	160	115		118	563			225	130				170	100
32-160.1/402	112M	x	x	50	32	80	116	125		250	234		160	160	115		118	584			225	130				170	100
32-160.1/552 ³⁾	132S	x	x	50	32	80	116	125	55	300	266	12		160	115	132	282	672	220	140			270	216	15	193	100
32-160.1/752 ³⁾	132S	x	x	50	32	80	116	125	55	300	266	12		160	115	132	282	672	220	140			270	216	15	193	100
32-200.1/302	100L	x		50	32	80	128	137		250	213		160	180	130		118	563			225	130				170	100
32-200.1/402	112M	x	x	50	32	80	128	137		250	234		160	180	130		118	584			225	130				170	100
32-200.1/552 ³⁾	132S	x	x	50	32	80	128	137	55	300	266	12		180	130	132	282	672	220	140			270	216	15	193	100
32-200.1/752 ³⁾	132S	x	x	50	32	80	128	137	55	300	266	12		180	130	132	282	672	220	140			270	216	15	193	100
32-200.1/1102 ³⁾	160M	x	x	50	32	80	128	137	70	350	325	15		180	130	160	334	852	300	210			320	254	21	226	100
32-200.1/1502 ³⁾	160M	x	x	50	32	80	128	137	70	350	325	15		180	130	160	334	852	300	210			320	254	21	226	100
32-250.1/552 ³⁾	132S	x		50	32	100	164	171	55	300	266	12		225	162	132	282	692	220	140			270	216	15	193	100
32-250.1/752 ³⁾	132S	x		50	32	100	164	171	55	300	266	12		225	162	132	282	692	220	140			270	216	15	193	100
32-250.1/1102 ³⁾	160M	x		50	32	100	164	171	70	350	325	15		225	162	160	334	872	300	210			320	254	21	226	100
32-250.1/1502 ³⁾	160M	x		50	32	100	164	171	70	350	325	15		225	162	160	334	872	300	210			320	254	21	226	100
32-125/112	80	x		50	32	80	113	113		200	162		160	140	103		118	491			225	130				156	100
32-125/152	90S	x	x	50	32	80	113	113		200	190		160	140	103		118	518			225	130				156	100
32-125/222	90L	x	x	50	32	80	113	113		200	190		160	140	103		118	525			225	130				156	100
32-125/302	100L	x	x	50	32	80	113	113		250	213		160	140	103		118	563			225	130				170	100
32-125/402	112M	x	x	50	32	80	113	113		250	234		160	140	103		118	584			225	130				170	100
32-125/552 ³⁾	132S	x	x	50	32	80	113	113	55	300	266	12		140	103	132	282	672	220	140			270	216	15	193	100
32-160/222	90L	x		50	32	80	113	125		200	190		160	160	115		118	525			225	130				156	100
32-160/302	100L	x	x	50	32	80	113	125		250	213		160	160	115		118	563			225	130				170	100
32-160/402	112M	x	x	50	32	80	113	125		250	234		160	160	115		118	584			225	130				170	100
32-160/552 ³⁾	132S	x	x	50	32	80	113	125	55	300	266	12		160	115	132	282	672	220	140			270	216	15	193	100
32-160/752 ³⁾	132S	x	x	50	32	80	113	125	55	300	266	12		160	115	132	282	672	220	140			270	216	15	193	100
32-200/402	112M	x		50	32	80	132	141		250	234		160	180	133		118	584			225	130				170	100
32-200/552 ³⁾	132S	x	x	50	32	80	132	141	55	300	266	12		180	133	132	282	672	220	140			270	216	15	193	100
32-200/752 ³⁾	132S	x	x	50	32	80	132	141	55	300	266	12		180	133	132	282	672	220	140			270	216	15	193	100
32-200/1102 ³⁾	160M	x	x	50	32	80	132	141	70	350	325	15		180	133	160	334	852	300	210			320	254	21	226	100
32-200/1502 ³⁾	160M	x	x	50	32	80	132	141	70	350	325	15		180	133	160	334	852	300	210			320	254	21	226	100
32-250/752 ³⁾	132S	x		50	32	100	176	176	55	300	266	12		225	168	132	282	692	220	140			270	216	15	193	100
32-250/1102 ³⁾	160M	x		50	32	100	176	176	70	350	325	15		225	168	160	334	872	300	210			320	254	21	226	100
32-250/1502 ³⁾	160M	x		50	32	100	176	176	70	350	325	15		225	168	160	334	872	300	210			320	254	21	226	100

1) Rc = ISO 7/1;

G = ISO 228/1

2) DN = EN 1092-2/DN.../PN 16/21/JL1040/B)

3) при этих типоразмерах опорные лапы электродвигателя должны стоять на фундаменте толщиной 20 мм

4) h₃ ≥ h₄

Etabloc GN, MN 40-125/... до 50-160/..., n = 2900 об/мин, n = 3500 об/мин

с опорными лапами (до типоразмера электродвигателя 112 = 4 кВт)
с опорной лапой электродвигателя
(начиная с типоразмера электродвигателя 132 = 5,5 кВт)

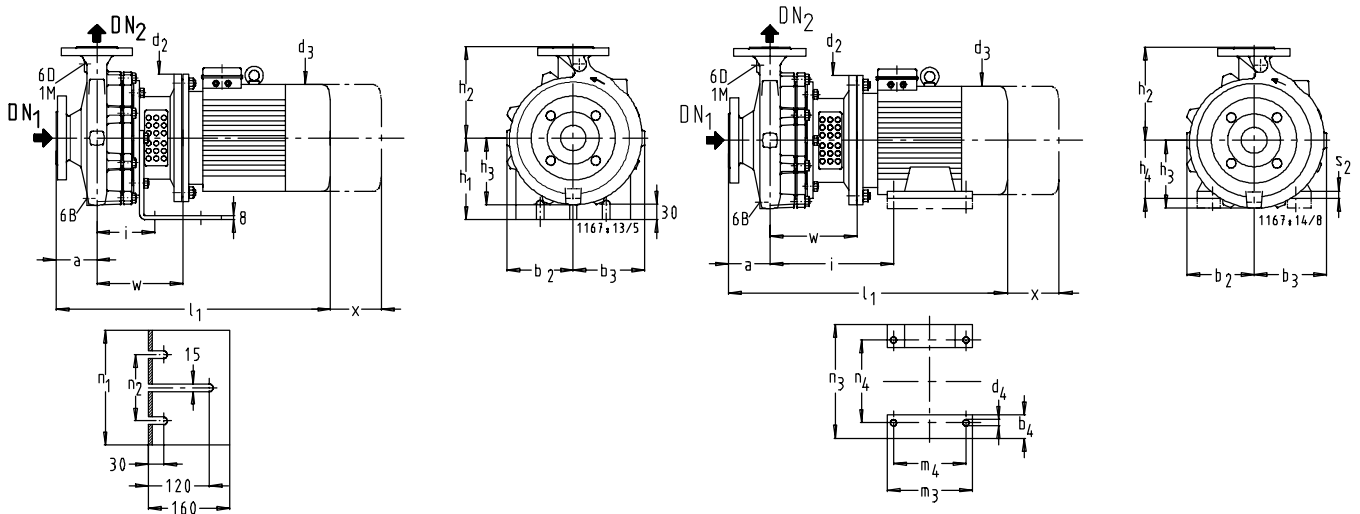

		Etabloc G, M			
		Etabloc GN, MN, BN		Etabloc SN, CN	
		DN ₂ 32 - DN ₂ 80	DN ₂ 100	DN ₂ 32 - DN ₂ 80	DN ₂ 100 - DN ₂ 150
1 M	Присоединение манометра	Rc 3/8 ¹⁾	Rc 1/2 ¹⁾	G 3/8 ¹⁾	G 1/2 ¹⁾
6 B	Перекачиваемая жидкость-Опорожнение	Rc 3/8 ¹⁾	Rc 1/2 ¹⁾	G 3/8 ¹⁾	G 1/2 ¹⁾
6 D	Перекачиваемая жидкость-Заполнение и опорожнение	Rc 3/8 ¹⁾	Rc 1/2 ¹⁾	G 3/8 ¹⁾	G 1/2 ¹⁾

Etabloc GN, MN	M	n = 2900	n = 3500	Допуски присоединительных размеров по EN 735																								
				DN ₁	DN ₂	a	b ₂ ≈	b ₃ ≈	b ₄ ≈	d ₂	d ₃ ≈	d ₄	h ₁	h ₂	h ₃	h ₄	i	l ₁ ≈	m ₃ ≈	m ₄	n ₁	n ₂	n ₃ ≈	n ₄	s ₂	w	x	
40-125/152	90S	x		65	40	80	113	113		200	190		160	140	103		118	518			225	130					156	100
40-125/222	90L	x	x	65	40	80	113	113		200	190		160	140	103		118	525			225	130					156	100
40-125/302	100L	x	x	65	40	80	113	113		250	213		160	140	103		118	563			225	130					170	100
40-125/402	112M	x	x	65	40	80	113	113		250	234		160	140	103		118	584			225	130					170	100
40-125/552 ³⁾	132S		x	65	40	80	113	113	55	300	266	12		140	103	132	282	672	220	140				270	216	15	193	100
40-125/752 ³⁾	132S		x	65	40	80	113	113	55	300	266	12		140	103	132	282	672	220	140				270	216	15	193	100
40-125/1102 ³⁾	160M		x	65	40	80	113	113	70	350	325	15		140	103	160	334	852	300	210				320	254	21	226	100
40-160/302	100L	x		65	40	80	115	131		250	213		160	160	118		118	563			225	130					170	100
40-160/402	112M	x	x	65	40	80	115	131		250	234		160	160	118		118	584			225	130					170	100
40-160/552 ³⁾	132S	x	x	65	40	80	115	131	55	300	266	12		160	118	132	282	672	220	140				270	216	15	193	100
40-160/752 ³⁾	132S	x	x	65	40	80	115	131	55	300	266	12		160	118	132	282	672	220	140				270	216	15	193	100
40-160/1102 ³⁾	160M	x	x	65	40	80	115	131	70	350	325	15		160	118	160	334	852	300	210				320	254	21	226	100
40-160/1502 ³⁾	160M		x	65	40	80	115	131	70	350	325	15		160	118	160	334	852	300	210				320	254	21	226	100
40-200/552 ³⁾⁴⁾	132S	x		65	40	100	140	152	55	300	266	12		180	140	132	282	692	220	140				270	216	15	193	100
40-200/752 ³⁾⁴⁾	132S	x	x	65	40	100	140	152	55	300	266	12		180	140	132	282	692	220	140				270	216	15	193	100
40-200/1102 ³⁾	160M	x	x	65	40	100	140	152	70	350	325	15		180	140	160	334	872	300	210				320	254	21	226	100
40-200/1502 ³⁾	160M	x	x	65	40	100	140	152	70	350	325	15		180	140	160	334	872	300	210				320	254	21	226	100
40-200/1852 ³⁾	160L		x	65	40	100	140	152	70	350	325	15		180	140	160	334	872	314	254				320	254	21	226	100
40-200/2202	180M		x	65	40	100	140	152	80	350	370	15		180	140	180	347	936	320	241				360	279	23	226	100
40-250/1102 ³⁾⁴⁾	160M	x		65	40	100	165	178	70	350	325	15		225	168	160	334	872	300	210				320	254	21	226	100
40-250/1502 ³⁾⁴⁾	160M	x		65	40	100	165	178	70	350	325	15		225	168	160	334	872	300	210				320	254	21	226	100
40-250/1852 ³⁾⁴⁾	160L	x		65	40	100	165	178	70	350	325	15		225	168	160	334	872	314	254				320	254	21	226	100
40-250/2202	180M	x		65	40	100	165	178	80	350	370	15		225	168	180	347	936	320	241				360	279	23	226	100
50-125/302	100L	x		65	50	100	113	128		250	213		160	160	112		118	583			225	130					170	100
50-125/402	112M	x		65	50	100	113	128		250	234		160	160	112		118	604			225	130					170	100
50-125/552 ³⁾	132S	x	x	65	50	100	113	128	55	300	266	12		160	112	132	282	692	220	140				270	216	15	193	100
50-125/752 ³⁾	132S	x	x	65	50	100	113	128	55	300	266	12		160	112	132	282	692	220	140				270	216	15	193	100
50-125/1102 ³⁾	160M		x	65	50	100	113	128	70	350	325	15		160	112	160	334	872	300	210				320	254	21	226	100
50-125/1502 ³⁾	160M		x	65	50	100	113	128	70	350	325	15		160	112	160	334	872	300	210				320	254	21	226	100
50-160/552 ³⁾⁴⁾	132S	x	x	65	50	100	126	147	55	300	266	12		180	134	132	282	692	220	140				270	216	15	193	100
50-160/752 ³⁾⁴⁾	132S	x	x	65	50	100	126	147	55	300	266	12		180	134	132	282	692	220	140				270	216	15	193	100
50-160/1102 ³⁾	160M	x	x	65	50	100	126	147	70	350	325	15		180	134	160	334	872	300	210				320	254	21	226	100
50-160/1502 ³⁾	160M	x	x	65	50	100	126	147	70	350	325	15		180	134	160	334	872	300	210				320	254	21	226	100
50-160/1852 ³⁾	160L		x	65	50	100	126	147	70	350	325	15		180	134	160	334	872	314	254				320	254	21	226	100
50-160/2202	180M		x	65	50	100	126	147	80	350	370	15		180	134	180	347	936	320	241				360	279	23	226	100

1) Rc = ISO 7/1;

G = ISO 228/1

2) EN 1092-2/DN.../PN 16/21/JL1040/B

3) при этих типоразмерах опорные лапы электродвигателя должны стоять на фундаменте толщиной 20 мм

4) h₃ ≥ h₄

Etabloc GN, MN 50-200/... до 100-160/..., n = 2900 об/мин, n = 3500 об/мин

с опорными лапами (до типоразмера электродвигателя 112 = 4 кВт)
 с опорной лапой электродвигателя
 (начиная с типоразмера электродвигателя 132 = 5,5 кВт)

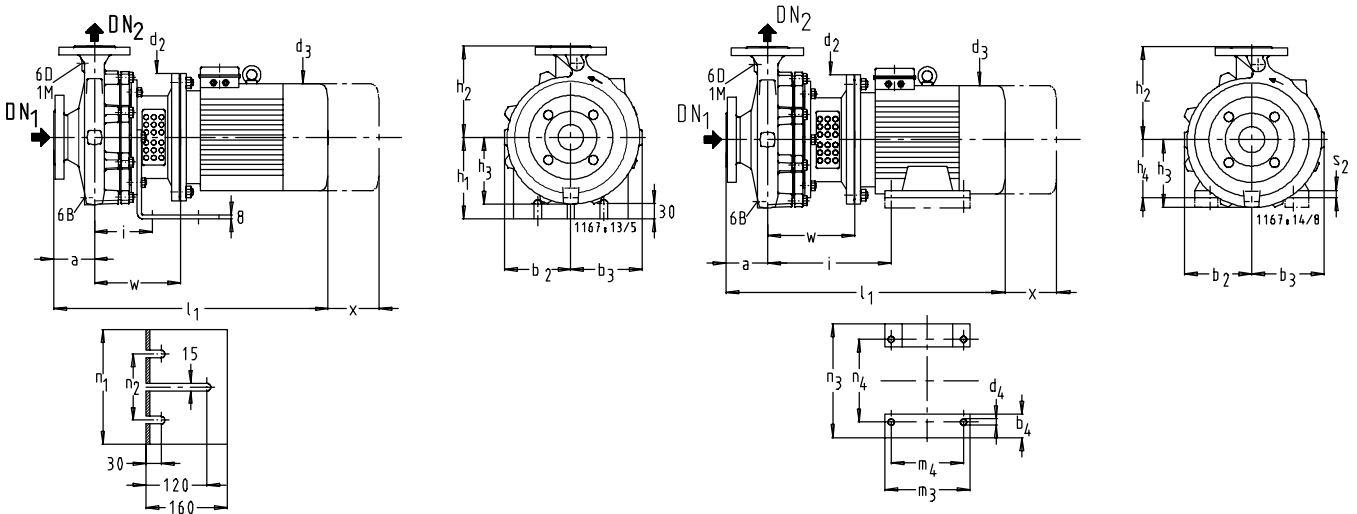

		Etabloc G, M		Etabloc SN, CN	
		Etabloc GN, MN, BN		DN ₂ 32 - DN ₂ 80	DN ₂ 100 - DN ₂ 150
1 M	Присоединение манометра	Rc 3/8 ¹⁾	Rc 1/2 ¹⁾	G 3/8 ¹⁾	G 1/2 ¹⁾
6 B	Перекачиваемая жидкость-Опорожнение	Rc 3/8 ¹⁾	Rc 1/2 ¹⁾	G 3/8 ¹⁾	G 1/2 ¹⁾
6 D	Перекачиваемая жидкость-Заполнение и опорожнение	Rc 3/8 ¹⁾	Rc 1/2 ¹⁾	G 3/8 ¹⁾	G 1/2 ¹⁾

Etabloc GN, MN	M	n = 2900	n = 3500	Допуски присоединительных размеров по EN 735																									
				DN ₁ ²⁾	DN ₂ ²⁾	a	b ₂ ≈	b ₃ ≈	b ₄ ≈	d ₂	d ₃ ≈	d ₄	h ₁	h ₂	h ₃	h ₄	i	l ₁ ≈	m ₃ ≈	m ₄	n ₁	n ₂	n ₃ ≈	n ₄	s ₂	w	x		
50-200/1102 ³⁾	160M	x	x	65	50	100	145	165	70	350	325	15		200	152	160	334	872	300	210					320	254	21	226	100
50-200/1502 ³⁾	160M	x	x	65	50	100	145	165	70	350	325	15		200	152	160	334	872	300	210					320	254	21	226	100
50-200/1852 ³⁾	160L	x	x	65	50	100	145	165	70	350	325	15		200	152	160	334	872	314	254					320	254	21	226	100
50-200/2202	180M	x	x	65	50	100	145	165	80	350	370	15		200	152	180	347	936	320	241					360	279	23	226	100
50-250/1502 ³⁾⁴⁾	160M	x		65	50	100	168	184	70	350	325	15		225	172	160	334	872	300	210					320	254	21	226	100
50-250/1852 ³⁾⁴⁾	160L	x		65	50	100	168	184	70	350	325	15		225	172	160	334	872	314	254					320	254	21	226	100
50-250/2202	180M	x		65	50	100	168	184	80	350	370	15		225	172	180	347	936	320	241					360	279	23	226	100
65-125/402	112M	x		80	65	100	120	148		250	234		160	180	132		118	604		225	130							170	100
65-125/552 ³⁾⁴⁾	132S	x	x	80	65	100	120	148	55	300	266	12		180	132	132	282	692	220	140					270	216	15	193	100
65-125/752 ³⁾⁴⁾	132S	x	x	80	65	100	120	148	55	300	266	12		180	132	132	282	692	220	140					270	216	15	193	100
65-125/1102 ³⁾	160M	x	x	80	65	100	120	148	70	350	325	15		180	132	160	334	872	300	210					320	254	21	226	100
65-125/1502 ³⁾	160M		x	80	65	100	120	148	70	350	325	15		180	132	160	334	872	300	210					320	254	21	226	100
65-160/752 ³⁾⁴⁾	132S	x		80	65	100	130	158	55	300	266	12		200	140	132	282	692	220	140					270	216	15	193	100
65-160/1102 ³⁾	160M	x	x	80	65	100	130	158	70	350	325	15		200	140	160	334	872	300	210					320	254	21	226	100
65-160/1502 ³⁾	160M	x	x	80	65	100	130	158	70	350	325	15		200	140	160	334	872	314	254					320	254	21	226	100
65-160/1852 ³⁾	160L		x	80	65	100	130	158	70	350	325	15		200	140	160	334	872	314	254					320	254	21	226	100
65-160/2202	180M		x	80	65	100	130	158	80	350	370	15		200	140	180	347	936	320	241					360	279	23	226	100
65-200/1502 ³⁾⁴⁾	160M	x		80	65	100	154	177	70	350	325	15		225	161	160	334	872	300	210					320	254	21	226	140
65-200/1852 ³⁾⁴⁾	160L	x	x	80	65	100	154	177	70	350	325	15		225	161	160	334	872	314	254					320	254	21	226	140
65-200/2202	180M	x	x	80	65	100	154	177	80	350	370	15		225	161	180	347	936	320	241					360	279	23	226	140
65-250/2202 ⁴⁾	180M	x		80	65	100	180	200	80	350	370	15		250	186	180	367	956	320	241					360	279	23	246	140
80-160/1102 ³⁾⁴⁾	160M	x		100	80	125	153	192	70	350	325	15		225	168	160	334	897	300	210					320	254	21	226	140
80-160/1502 ³⁾⁴⁾	160M	x		100	80	125	153	192	70	350	325	15		225	168	160	334	897	300	210					320	254	21	226	140
80-160/1852 ³⁾⁴⁾	160L	x		100	80	125	153	192	70	350	325	15		225	168	160	334	897	314	254					320	254	21	226	140
80-160/2202	180M	x	x	100	80	125	153	192	80	350	370	15		225	168	180	347	961	320	241					360	279	23	226	140
80-200/1852 ³⁾⁴⁾	160L	x		100	80	125	161	189	70	350	325	15		250	170	160	354	917	314	254					320	254	21	246	140
80-200/2202	180M	x		100	80	125	161	189	80	350	370	15		250	170	180	367	981	320	241					360	279	23	246	140
100-160/2202 ⁴⁾	180M	x		125	100	125	178	225	80	350	370	15		280	196	180	367	981	320	241					360	279	23	246	140

1) Rc = ISO 7/1;
 G = ISO 22B/1
 2) DN = EN 109202/DN.../PN 16/21/JL1040/B
 3) при этих типоразмерах опорные лапы электродвигателя должны стоять на фундаменте толщиной 20 мм
 4) $h_3 \geq h_4$

Etabloc GN, MN 32-125.1/... до 40-125/..., n = 1450 об/мин, n = 1750 об/мин

с опорными лапами типоразмера электродвигателя 112 = 4 кВт)

с опорной лапой электродвигателя

(начиная с типоразмера электродвигателя 132 = 5,5 кВт)

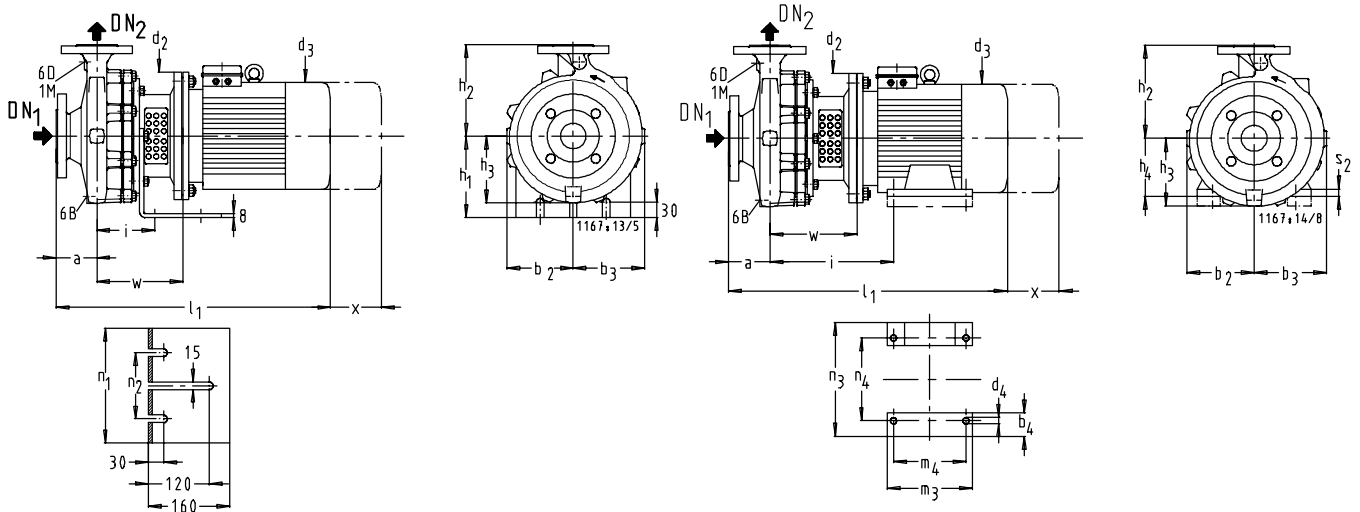

		Etabloc G, M			
		Etabloc GN, MN, BN		Etabloc SN, CN	
		DN ₂ 32 - DN ₂ 80	DN ₂ 100	DN ₂ 32 - DN ₂ 80	DN ₂ 100 - DN ₂ 150
1 M	Присоединение манометра	Rc 3/8 ¹⁾	Rc 1/2 ¹⁾	G 3/8 ¹⁾	G 1/2 ¹⁾
6 B	Перекачиваемая жидкость-Опорожнение	Rc 3/8 ¹⁾	Rc 1/2 ¹⁾	G 3/8 ¹⁾	G 1/2 ¹⁾
6 D	Перекачиваемая жидкость-Заполнение и опорожнение	Rc 3/8 ¹⁾	Rc 1/2 ¹⁾	G 3/8 ¹⁾	G 1/2 ¹⁾

Etabloc GN, MN	M	n = 1450	n = 1750	Допуски присоединительных размеров по EN 735																								
				DN ₁	DN ₂	a	b ₂ ≈	b ₃ ≈	b ₄ ≈	d ₂	d ₃ ≈	d ₄	h ₁	h ₂	h ₃	h ₄	i	l ₁ ≈	m ₃ ≈	m ₄	n ₁	n ₂	n ₃ ≈	n ₄	s ₂	w	x	
32-125.1/024	71	x	x	50	32	80	113	113		160	145		160	140	103		118	437			225	130					136	100
32-125.1/034	71	x	x	50	32	80	113	113		160	145		160	140	103		118	437			225	130					136	100
32-125.1/054	80	x	x	50	32	80	113	113		200	162		160	140	103		118	491			225	130					156	100
32-160.1/034	71	x	x	50	32	80	116	125		160	145		160	160	115		118	437			225	130					136	100
32-160.1/054	80	x	x	50	32	80	116	125		200	162		160	160	115		118	491			225	130					156	100
32-160.1/074	80		x	50	32	80	116	125		200	162		160	160	115		118	491			225	130					156	100
32-160.1/114	90S		x	50	32	80	116	125		200	190		160	160	115		118	518			225	130					156	100
32-200.1/054	80	x	x	50	32	80	128	137		200	162		160	180	130		118	491			225	130					156	100
32-200.1/074	80	x	x	50	32	80	128	137		200	162		160	180	130		118	491			225	130					156	100
32-200.1/114	90S		x	50	32	80	128	137		200	190		160	180	130		118	518			225	130					156	100
32-200.1/154	90L		x	50	32	80	128	137		200	190		160	180	130		118	525			225	130					156	100
32-200.1/224	100L		x	50	32	80	128	137		250	213		160	180	130		118	563			225	130					170	100
32-250.1/074 ⁴⁾	80	x		50	32	100	164	171		200	162		160	225	162		118	511			225	130					156	100
32-250.1/114 ⁴⁾	90S	x	x	50	32	100	164	171		200	190		160	225	162		118	538			225	130					156	100
32-250.1/154 ⁴⁾	90L	x	x	50	32	100	164	171		200	190		160	225	162		118	545			225	130					156	100
32-250.1/224 ⁴⁾	100L		x	50	32	100	164	171		250	213		160	225	162		118	583			225	130					170	100
32-250.1/304 ⁴⁾	100L		x	50	32	100	164	171		250	213		160	225	162		118	583			225	130					170	100
32-125/034	71	x	x	50	32	80	113	113		160	145		160	140	103		118	437			225	130					136	100
32-125/054	80	x	x	50	32	80	113	113		200	162		160	140	103		118	491			225	130					156	100
32-125/074	80		x	50	32	80	113	113		200	162		160	140	103		118	491			225	130					156	100
32-160/054	80	x	x	50	32	80	113	125		200	162		160	160	115		118	491			225	130					156	100
32-160/074	80		x	50	32	80	113	125		200	162		160	160	115		118	491			225	130					156	100
32-160/114	90S		x	50	32	80	113	125		200	190		160	160	115		118	518			225	130					156	100
32-200/054	80	x		50	32	80	132	141		200	162		160	180	133		118	491			225	130					156	100
32-200/074	80	x	x	50	32	80	132	141		200	162		160	180	133		118	491			225	130					156	100
32-200/114	90S	x	x	50	32	80	132	141		200	190		160	180	133		118	518			225	130					156	100
32-200/154	90L		x	50	32	80	132	141		200	190		160	180	133		118	525			225	130					156	100
32-200/224	100L		x	50	32	80	132	141		250	213		160	180	133		118	563			225	130					170	100
32-250/114 ⁴⁾	90S	x		50	32	100	170	176		200	190		160	225	168		118	538			225	130					156	100
32-250/154 ⁴⁾	90L	x		50	32	100	170	176		200	190		160	225	168		118	545			225	130					156	100
32-250/224 ⁴⁾	100L	x	x	50	32	100	170	176		250	213		160	225	168		118	583			225	130					170	100
32-250/304 ⁴⁾	100L		x	50	32	100	170	176		250	213		160	225	168		118	583			225	130					170	100
32-250/404 ⁴⁾	112M		x	50	32	100	170	176		250	234		160	225	168		118	604			225	130					170	100
32-250/554 ³⁾⁴⁾	132S		x	50	32	100	170	176	55	300	266	12		225	168	132	282	692	220	140			270	216	15	193	100	
40-125/024	71	x		65	40	80	113	113		160	145		160	140	103		118	437			225	130					136	100
40-125/034	71	x		65	40	80	113	113		160	145		160	140	103		118	437			225	130					136	100
40-125/054	80	x	x	65	40	80	113	113		200	162		160	140	103		118	491			225	130					156	100
40-125/074	80		x	65	40	80	113	113		200	162		160	140	103		118	491			225	130					156	100
40-125/114	90S		x	65	40	80	113	113		200	190		160	140	103		118	518			225	130					156	100

1) Rc = ISO 7/1; G = ISO 228/1

2) DN = EN 1092-2/DN.../PN 16/21/JL1040/B

3) при этих типоразмерах опорные лапы электродвигателя должны стоять на фундаменте толщиной 20 мм

 4) h₃ ≥ h₁ / h₃ ≥ h₄

Etabloc GN, MN 40-160/... до 50-200/..., n = 1450 об/мин, n = 1750 об/мин

с опорными лапами (до типоразмера электродвигателя 112 = 4 кВт)
с опорной лапой электродвигателя
(начиная с типоразмера электродвигателя 132 = 5,5 кВт)

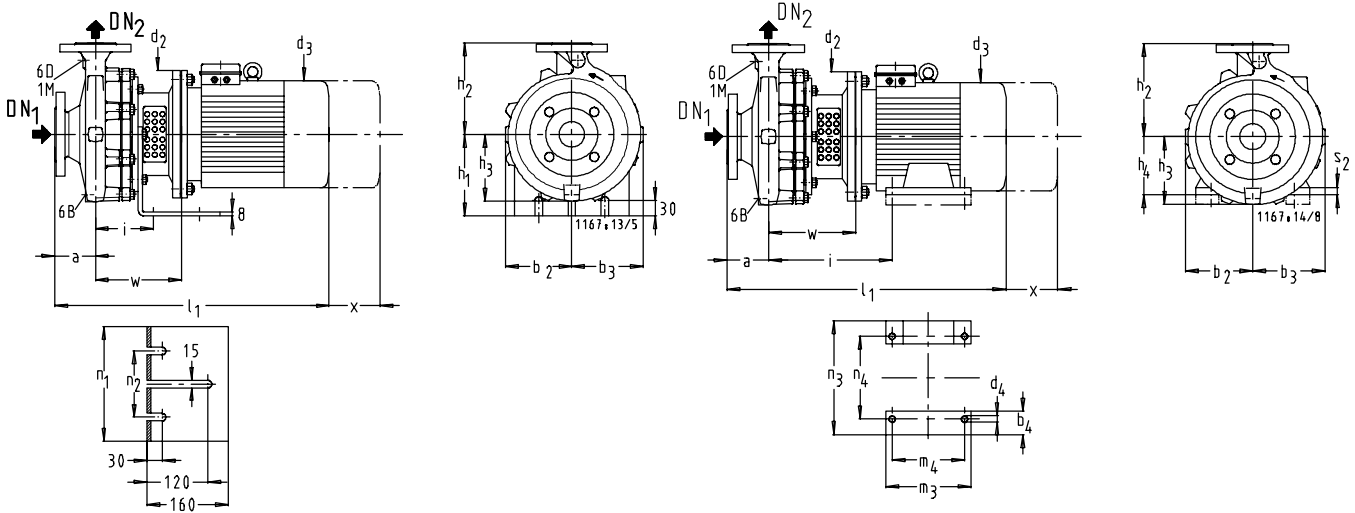

		Etabloc G, M		Etabloc SN, CN	
		Etabloc GN, MN, BN		DN ₂ 32 - DN ₂ 80	DN ₂ 100 - DN ₂ 150
1 M	Присоединение манометра	Rc 3/8 ¹⁾	Rc 1/2 ¹⁾	G 3/8 ¹⁾	G 1/2 ¹⁾
6 B	Перекачиваемая жидкость-Опорожнение	Rc 3/8 ¹⁾	Rc 1/2 ¹⁾	G 3/8 ¹⁾	G 1/2 ¹⁾
6 D	Перекачиваемая жидкость-Заполнение и опорожнение	Rc 3/8 ¹⁾	Rc 1/2 ¹⁾	G 3/8 ¹⁾	G 1/2 ¹⁾

Etabloc GN, MN	M	n = 1450	n = 1750	Допуски присоединительных размеров по EN 735																								
				DN ₁	DN ₂	a	b ₂ ≈	b ₃ ≈	b ₄ ≈	d ₂	d ₃ ≈	d ₄	h ₁	h ₂	h ₃	h ₄	i	l ₁ ≈	m ₃ ≈	m ₄	n ₁	n ₂	n ₃ ≈	n ₄	s ₂	w	x	
40-160/054	80	x		65	40	80	115	131		200	162	160	160	118	118	491					225	130					156	100
40-160/074	80	x	x	65	40	80	115	131		200	162	160	160	118	118	491					225	130					156	100
40-160/114	90S	x	x	65	40	80	115	131		200	190	160	160	118	118	518					225	130					156	100
40-160/154	90L		x	65	40	80	115	131		200	190	160	160	118	118	525					225	130					156	100
40-160/224	100L		x	65	40	80	115	131		250	213	160	160	118	118	563					225	130					170	100
40-200/074	80	x		65	40	100	140	152		200	162	160	180	140	118	511					225	130					156	100
40-200/114	90S	x		65	40	100	140	152		200	190	160	180	140	118	538					225	130					156	100
40-200/154	90L	x	x	65	40	100	140	152		200	190	160	180	140	118	545					225	130					156	100
40-200/224	100L		x	65	40	100	140	152		250	213	160	180	140	118	583					225	130					170	100
40-200/304	100L		x	65	40	100	140	152		250	213	160	180	140	118	583					225	130					170	100
40-250/114 ⁴⁾	90S	x		65	40	100	165	178		200	190	160	225	168	118	538					225	130					156	100
40-250/154 ⁴⁾	90L	x		65	40	100	165	178		200	190	160	225	168	118	545					225	130					156	100
40-250/224 ⁴⁾	100L	x	x	65	40	100	165	178		250	213	160	225	168	118	583					225	130					170	100
40-250/304 ⁴⁾	100L	x	x	65	40	100	165	178		250	213	160	225	168	118	583					225	130					170	100
40-250/404 ⁴⁾	112M		x	65	40	100	165	178		250	234	160	225	168	118	604					225	130					170	100
40-250/554 ³⁾⁴⁾	132S		x	65	40	100	165	178	55	300	266	12		225	168	132	282	692	220	140			270	216	15	193	100	
40-315/224 ⁴⁾	100L	x		65	40	125	194	203		250	213	180	250	196	142	628					260	180					190	100
40-315/304 ⁴⁾	100L	x		65	40	125	194	203		250	213	180	250	196	142	628					260	180					190	100
40-315/404 ⁴⁾	112M	x	x	65	40	125	194	203		250	234	180	250	196	142	649					260	180					190	100
40-315/554 ³⁾⁴⁾	132S	x	x	65	40	125	194	203	55	300	266	12		250	196	132	302	737	220	140			270	216	15	213	100	
40-315/754 ³⁾⁴⁾	132M		x	65	40	125	194	203	59	300	298	12		250	196	132	302	759	240	178			270	216	15	213	100	
40-315/1104 ³⁾⁴⁾	160M		x	65	40	125	194	203	70	350	325	15		250	196	160	354	917	300	210			320	254	21	246	100	
50-125/054	80	x		65	50	100	113	128		200	162	160	160	112	118	511					225	130					156	100
50-125/074	80	x	x	65	50	100	113	128		200	162	160	160	112	118	511					225	130					156	100
50-125/114	90S	x	x	65	50	100	113	128		200	190	160	160	112	118	538					225	130					156	100
50-125/154	90L		x	65	50	100	113	128		200	190	160	160	112	118	545					225	130					156	100
50-160/074	80	x		65	50	100	126	147		200	162	160	180	134	118	511					225	130					156	100
50-160/114	90S	x	x	65	50	100	126	147		200	190	160	180	134	118	538					225	130					156	100
50-160/154	90L	x	x	65	50	100	126	147		200	190	160	180	134	118	545					225	130					156	100
50-160/224	100L		x	65	50	100	126	147		250	213	160	180	134	118	583					225	130					170	100
50-160/304	100L		x	65	50	100	126	147		250	213	160	180	134	118	583					225	130					170	100
50-200/154	90L	x		65	50	100	145	165		200	190	160	200	152	118	545					225	130					156	100
50-200/224	100L	x	x	65	50	100	145	165		250	213	160	200	152	118	583					225	130					170	100
50-200/304	100L		x	65	50	100	145	165		250	213	160	200	152	118	583					225	130					170	100
50-200/404	112M		x	65	50	100	145	165		250	234	160	200	152	118	604					225	130					170	100
50-200/554 ³⁾⁴⁾	132S		x	65	50	100	145	165	55	300	266	12		200	152	132	282	692	220	140			270	216	15	193	100	

1) Rc = ISO 7/1;
G = ISO 228/1

2) DN = EN 1092-2/DN.../PN 16/21/JL1040/B

3) При этих типоразмерах опорные лапы электродвигателя должны стоять на фундаменте толщиной 20 мм

4) h₃ ≥ h₁ / h₃ ≥ h₄

Etabloc GN, MN 50-250/... до 65-315/..., n = 1450 об/мин, n = 1750 об/мин

с опорными лапами (до типоразмера электродвигателя 112 = 4 кВт)
с опорной лапой электродвигателя
(начиная с типоразмера электродвигателя 132 = 5,5 кВт)

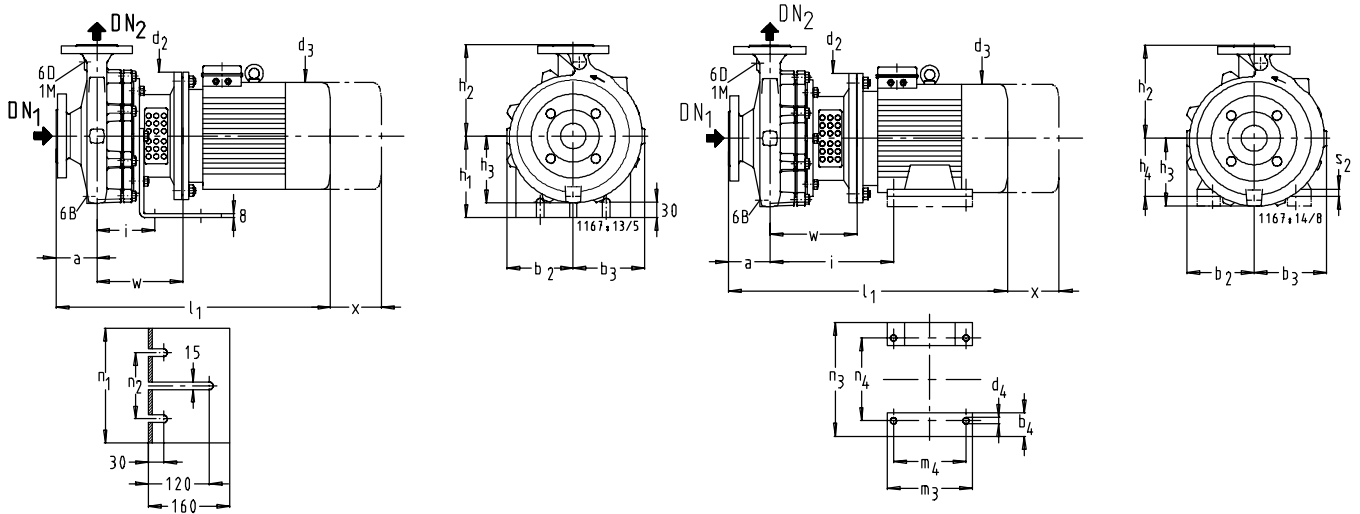

		Etabloc G, M			
		Etabloc GN, MN, BN		Etabloc SN, CN	
		DN ₂ 32 - DN ₂ 80	DN ₂ 100	DN ₂ 32 - DN ₂ 80	DN ₂ 100 - DN ₂ 150
1 M	Присоединение манометра	Rc 3/8 ¹⁾	Rc 1/2 ¹⁾	G 3/8 ¹⁾	G 1/2 ¹⁾
6 B	Перекачиваемая жидкость-Опорожнение	Rc 3/8 ¹⁾	Rc 1/2 ¹⁾	G 3/8 ¹⁾	G 1/2 ¹⁾
6 D	Перекачиваемая жидкость-Заполнение и опорожнение	Rc 3/8 ¹⁾	Rc 1/2 ¹⁾	G 3/8 ¹⁾	G 1/2 ¹⁾

MM

Etabloc GN, MN	M	n = 1450	n = 1750	Допуски присоединительных размеров по EN 735																								
				DN ₁	DN ₂	a	b ₂ ≈	b ₃ ≈	b ₄ ≈	d ₂	d ₃ ≈	d ₄	h ₁	h ₂	h ₃	h ₄	i	l ₁ ≈	m ₃ ≈	m ₄	n ₁	n ₂	n ₃ ≈	n ₄	s ₂	w	x	
50-250/224 ⁴⁾	100L	x	x	65	50	100	168	184		250	213		160	225	172		118	583			225	130					170	100
50-250/304 ⁴⁾	100L	x		65	50	100	168	184		250	213		160	225	172		118	583			225	130					170	100
50-250/404 ⁴⁾	112M	x	x	65	50	100	168	184		250	234		160	225	172		118	604			225	130					170	100
50-250/554 ³⁾⁴⁾	132S		x	65	50	100	168	184	55	300	266	12		225	172	132	282	692	220	140				270	216	15	193	100
50-250/754 ³⁾⁴⁾	132M		x	65	50	100	168	184	59	300	298	12		225	172	132	282	714	240	178			270	216	15	193	100	
50-250/1104 ³⁾⁴⁾	160M		x	65	50	100	168	184	70	350	325	15		225	172	160	334	872	300	210			320	254	21	226	100	
50-315/304 ⁴⁾	100L	x		65	50	125	200	216		250	213		180	280	204		142	628			260	180					190	100
50-315/404 ⁴⁾	112M	x		65	50	125	200	216		250	234		180	280	204		142	649			260	180					190	100
50-315/554 ³⁾⁴⁾	132S	x	x	65	50	125	200	216	55	300	266	12		280	204	132	302	737	220	140			270	216	15	213	100	
50-315/754 ³⁾⁴⁾	132M	x	x	65	50	125	200	216	59	300	298	12		280	204	132	302	759	240	178			270	216	15	213	100	
50-315/1104 ³⁾⁴⁾	160M		x	65	50	125	200	216	70	350	325	15		280	204	160	354	917	300	210			320	254	21	246	100	
50-315/1504 ³⁾⁴⁾	160L		x	65	50	125	200	216	70	350	325	15		280	204	160	354	917	314	254			320	254	21	246	100	
65-125/054	80	x		80	65	100	120	148		200	162		160	180	132		118	511			225	130					156	100
65-125/074	80	x	x	80	65	100	120	148		200	162		160	180	132		118	511			225	130					156	100
65-125/114	90S	x	x	80	65	100	120	148		200	190		160	180	132		118	538			225	130					156	100
65-125/154	90L		x	80	65	100	120	148		200	190		160	180	132		118	545			225	130					156	100
65-125/224	100L		x	80	65	100	120	148		250	213		160	180	132		118	583			225	130					170	100
65-160/114	90S	x		80	65	100	130	158		200	190		160	200	140		118	538			225	130					156	100
65-160/154	90L	x	x	80	65	100	130	158		200	190		160	200	140		118	545			225	130					156	100
65-160/224	100L	x	x	80	65	100	130	158		250	213		160	200	140		118	583			225	130					170	100
65-160/304	100L		x	80	65	100	130	158		250	213		160	200	140		118	583			225	130					170	100
65-160/404	112M		x	80	65	100	130	158		250	234		160	200	140		118	604			225	130					170	100
65-200/224 ⁴⁾	100L	x		80	65	100	154	177		250	213		160	225	161		118	583			225	130					170	140
65-200/304 ⁴⁾	100L	x		80	65	100	154	177		250	213		160	225	161		118	583			225	130					170	140
65-200/404 ⁴⁾	112M	x	x	80	65	100	154	177		250	234		160	225	161		118	604			225	130					170	140
65-200/554 ³⁾⁴⁾	132S		x	80	65	100	154	177	55	300	266	12		225	161	132	282	692	220	140			270	216	15	193	140	
65-200/754 ³⁾⁴⁾	132M		x	80	65	100	154	177	59	300	298	12		225	161	132	282	714	240	178			270	216	15	193	140	
65-250/304 ⁴⁾	100L	x		80	65	100	180	200		250	213		180	250	186		142	603			260	180					190	140
65-250/404 ⁴⁾	112M	x		80	65	100	180	200		250	234		180	250	186		142	624			260	180					190	140
65-250/554 ³⁾⁴⁾	132S	x	x	80	65	100	180	200	55	300	266	12		250	186	132	302	712	220	140			270	216	15	213	140	
65-250/754 ³⁾⁴⁾	132M		x	80	65	100	180	200	59	300	298	12		250	186	132	302	734	240	178			270	216	15	213	140	
65-250/1104 ³⁾⁴⁾	160M		x	80	65	100	180	200	70	350	325	15		250	186	160	354	892	300	210			320	254	21	246	140	
65-315/554 ³⁾⁴⁾	132S	x		80	65	125	208	229	55	300	266	12		280	214	132	302	737	220	140			270	216	15	213	140	
65-315/754 ³⁾⁴⁾	132M	x		80	65	125	208	229	59	300	298	12		280	214	132	302	759	240	178			270	216	15	213	140	
65-315/1104 ³⁾⁴⁾	160M	x	x	80	65	125	208	229	70	350	325	15		280	214	160	354	917	300	210			320	254	21	246	140	
65-315/1504 ³⁾⁴⁾	160L	x	x	80	65	125	208	229	70	350	325	15		280	214	160	354	917	314	254			320	254	21	246	140	
65-315/1854 ⁴⁾	180M		x	80	65	125	208	229	80	350	370	15		280	214	180	367	981	320	241			360	279	23	246	140	
65-315/2204 ⁴⁾	180L		x	80	65	125	208	229	80	350	370	15		280	214	180	367	981	358	279			360	279	23	246	140	

1) Rc = ISO 7/1;

2) DN = EN 1092-2/DN.../PN 16/21/JL1040/B

3) при этих типоразмерах опорные лапы электродвигателя должны стоять на фундаменте толщиной 20 мм

 4) h₃ ≥ h₁ / h₃ ≥ h₄

Etabloc GN, MN 80-160/... до 100-250/..., n = 1450 об/мин, n = 1750 об/мин

с опорными лапами (до типоразмера электродвигателя 112 = 4 кВт)
 с опорной лапой электродвигателя
 (начиная с типоразмера электродвигателя 132 = 5,5 кВт)

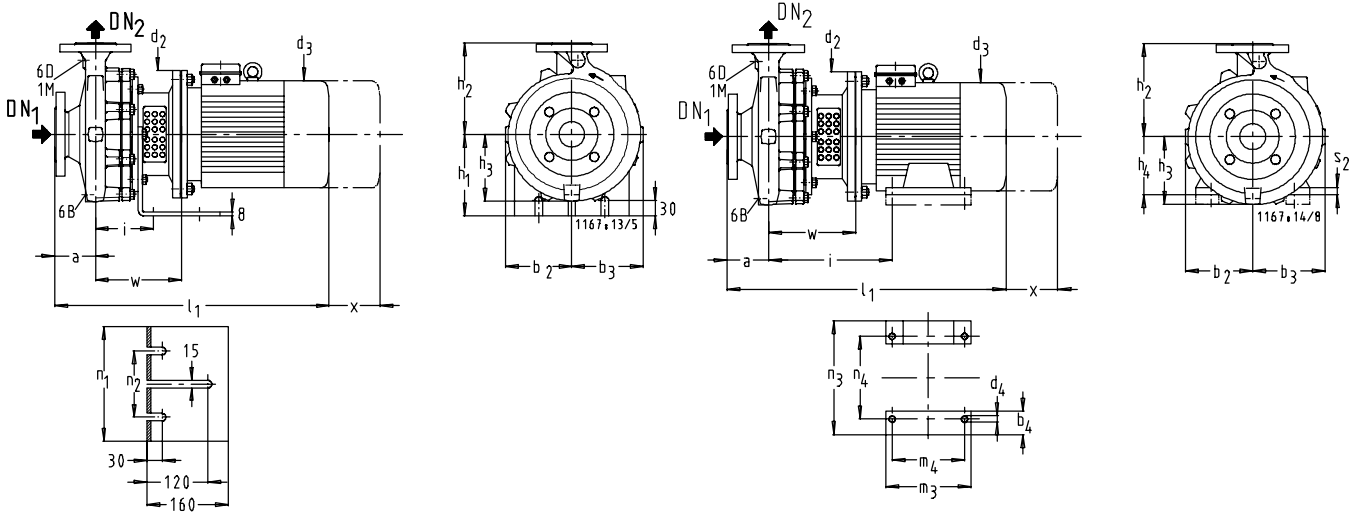

		Etabloc G, M		Etabloc GN, MN, BN		Etabloc SN, CN			
				DN ₂ 32 - DN ₂ 80	DN ₂ 100	DN ₂ 32 - DN ₂ 80	DN ₂ 100 - DN ₂ 150		
1 M	Присоединение манометра	Rc 3/8 ¹⁾	Rc 1/2 ¹⁾	G 3/8 ¹⁾	G 1/2 ¹⁾				
6 B	Перекачиваемая жидкость-Опорожнение	Rc 3/8 ¹⁾	Rc 1/2 ¹⁾	G 3/8 ¹⁾	G 1/2 ¹⁾				
6 D	Перекачиваемая жидкость-Заполнение и опорожнение	Rc 3/8 ¹⁾	Rc 1/2 ¹⁾	G 3/8 ¹⁾	G 1/2 ¹⁾				

MM

Etabloc GN, MN	M	n = 1450	n = 1750	Допуски присоединительных размеров по EN 735																								
				DN ₁	DN ₂	a	b ₂ ≈	b ₃ ≈	b ₄ ≈	d ₂	d ₃ ≈	d ₄	h ₁	h ₂	h ₃	h ₄	i	l ₁ ≈	m ₃ ≈	m ₄	n ₁	n ₂	n ₃ ≈	n ₄	s ₂	w	x	
80-160/154 ⁴⁾	90L	x		100	80	125	153	192		200	190		160	225	168		118	570				225	130				156	140
80-160/224 ⁴⁾	100L	x		100	80	125	153	192		250	213		160	225	168		118	608				225	130				170	140
80-160/304 ⁴⁾	100L	x		100	80	125	153	192		250	213		160	225	168		118	608				225	130				170	140
80-160/404 ⁴⁾	112M	x	x	100	80	125	153	192		250	234		160	225	168		118	629				225	130				170	140
80-160/554 ³⁾⁴⁾	132S		x	100	80	125	153	192	55	300	266	12		225	168	132	282	717	220	140				270	216	15	193	140
80-200/224	100L	x		100	80	125	161	189		250	213		180	250	170		142	628				260	180				190	140
80-200/304	100L	x		100	80	125	161	189		250	213		180	250	170		142	628				260	180				190	140
80-200/404	112M	x		100	80	125	161	189		250	234		180	250	170		142	649				260	180				190	140
80-200/554 ³⁾⁴⁾	132S	x	x	100	80	125	161	189	55	300	266	12		250	170	132	302	737	220	140				270	216	15	213	140
80-200/754 ³⁾⁴⁾	132M		x	100	80	125	161	189	59	300	298	12		250	170	132	302	759	240	178				270	216	15	213	140
80-200/1104 ³⁾⁴⁾	160M		x	100	80	125	161	189	70	350	325	15		250	170	160	354	917	300	210				320	254	21	246	140
80-250/404 ⁴⁾	112M	x		100	80	125	184	210		250	234		180	280	195		142	649				260	180				190	140
80-250/554 ³⁾⁴⁾	132S	x		100	80	125	184	210	55	300	266	12		280	195	132	302	737	220	140				270	216	15	213	140
80-250/754 ³⁾⁴⁾	132M	x	x	100	80	125	184	210	59	300	298	12		280	195	132	302	759	240	178				270	216	15	213	140
80-250/1104 ³⁾⁴⁾	160M	x	x	100	80	125	184	210	70	350	325	15		280	195	160	354	917	300	210				320	254	21	246	140
80-250/1504 ³⁾⁴⁾	160L		x	100	80	125	184	210	70	350	325	15		280	195	160	354	917	314	254				320	254	21	246	140
80-250/1854 ⁴⁾	180M		x	100	80	125	184	210	80	350	370	15		280	195	180	367	981	320	241				360	279	23	246	140
80-315/754 ³⁾⁴⁾	132M	x		100	80	125	220	244	59	300	298	12		315	228	132	302	759	240	178				270	216	15	213	140
80-315/1104 ³⁾⁴⁾	160M	x		100	80	125	220	244	70	350	325	15		315	228	160	354	917	300	210				320	254	21	246	140
80-315/1504 ³⁾⁴⁾	160L	x	x	100	80	125	220	244	70	350	325	15		315	228	160	354	917	314	254				320	254	21	246	140
80-315/1854 ⁴⁾	180M	x	x	100	80	125	220	244	80	350	370	15		315	228	180	367	981	320	241				360	279	23	246	140
80-315/2204 ⁴⁾	180L	x	x	100	80	125	220	244	80	350	370	15		315	228	180	367	981	358	279				360	279	23	246	140
100-160/304 ⁴⁾	100L	x		125	100	125	178	225		250	213		180	280	196		142	628				260	180				190	140
100-160/404 ⁴⁾	112M	x		125	100	125	178	225		250	234		180	280	196		142	649				260	180				190	140
100-160/554 ³⁾⁴⁾	132S	x	x	125	100	125	178	225	55	300	266	12		280	196	132	302	737	220	140				270	216	15	213	140
100-160/754 ³⁾⁴⁾	132M		x	125	100	125	178	225	59	300	298	12		280	196	132	302	759	240	178				270	216	15	213	140
100-200/404 ⁴⁾	112M	x		125	100	125	173	213		250	234		180	280	190		0	649				260	180				190	140
100-200/554 ³⁾⁴⁾	132S	x		125	100	125	173	213	55	300	266	12		280	190	132	302	737	220	140				270	216	15	213	140
100-200/754 ³⁾⁴⁾	132M	x	x	125	100	125	173	213	59	300	298	12		280	190	132	302	759	240	178				270	216	15	213	140
100-200/1104 ³⁾⁴⁾	160M		x	125	100	125	173	213	70	350	325	15		280	190	160	354	917	300	210				320	254	21	246	140
100-200/1504 ³⁾⁴⁾	160L		x	125	100	125	173	213	70	350	325	15		280	190	160	354	917	314	254				320	254	21	246	140
100-250/754 ³⁾⁴⁾	132M	x		125	100	140	190	220	59	300	298	12		280	201	132	302	774	240	178				270	216	15	213	140
100-250/1104 ³⁾⁴⁾	160M	x	x	125	100	140	190	220	70	350	325	15		280	201	160	354	932	300	210				320	254	21	246	140
100-250/1504 ³⁾⁴⁾	160L	x	x	125	100	140	190	220	70	350	325	15		280	201	160	354	932	314	254				320	254	21	246	140
100-250/1854 ⁴⁾	180M		x	125	100	140	190	220	80	350	370	15		280	201	180	367	996	320	241				360	279	23	246	140
100-250/2204 ⁴⁾	180L		x	125	100	140	190	220	80	350	370	15		280	201	180	367	996	358	279				360	279	23	246	140

1) Rc = ISO 7/1;

G = ISO 228/1

2) DN = EN 1092-2/DN.../PN 16/21/JL1040/B

DN 200 = EN 1092-2/DN 200/PN 10/21/JL1040/B

3) при этих типоразмерах опорные лапы электродвигателя должны стоять на фундаменте толщиной 20 мм

 4) $h_3 \geq h_1 / h_3 \geq h_4$

Etabloc GN, MN 100-315/... до 150-250/..., n = 1450 об/мин, n = 1750 об/мин

с опорными лапами типоразмера электродвигателя 112 = 4 кВт)

с опорной лапой электродвигателя

(начиная с типоразмера электродвигателя 132 = 5,5 кВт)

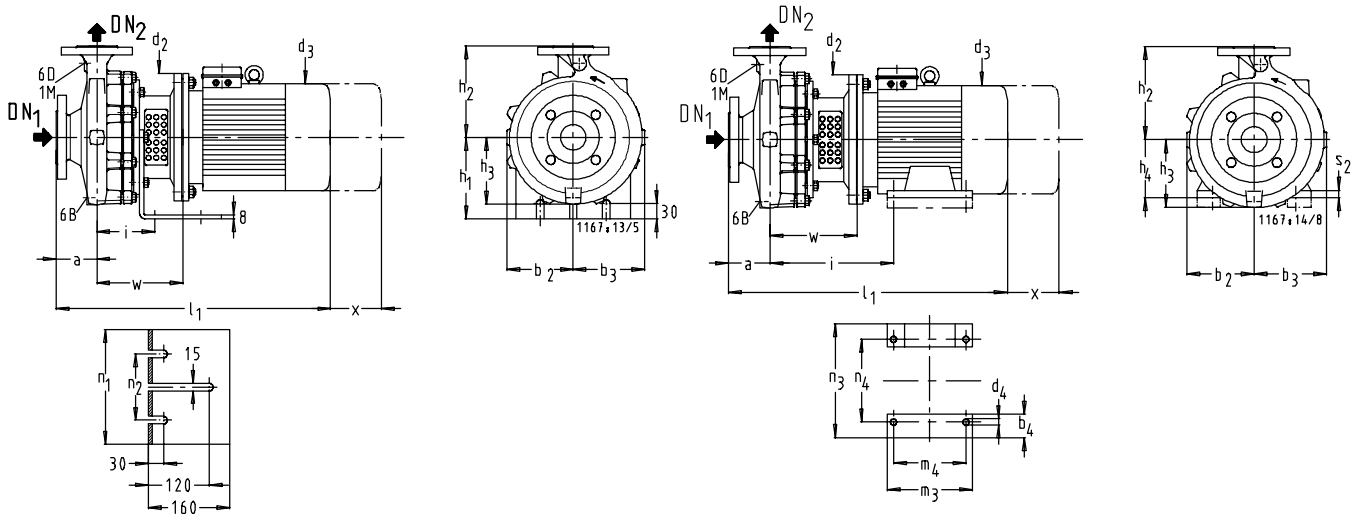

		Etabloc G, M		Etabloc SN, CN	
		Etabloc GN, MN, BN		DN ₂ 32 - DN ₂ 80	DN ₂ 100 - DN ₂ 150
1 M	Присоединение манометра	Rc 3/8 ¹⁾	Rc 1/2 ¹⁾	G 3/8 ¹⁾	G 1/2 ¹⁾
6 B	Перекачиваемая жидкость-Опорожнение	Rc 3/8 ¹⁾	Rc 1/2 ¹⁾	G 3/8 ¹⁾	G 1/2 ¹⁾
6 D	Перекачиваемая жидкость-Заполнение и опорожнение	Rc 3/8 ¹⁾	Rc 1/2 ¹⁾	G 3/8 ¹⁾	G 1/2 ¹⁾

Etabloc GN, MN	M	n = 1450	n = 1750	Допуски присоединительных размеров по EN 735																								
				DN ₁	DN ₂	a	b ₂ ≈	b ₃ ≈	b ₄ ≈	d ₂	d ₃ ≈	d ₄	h ₁	h ₂	h ₃	h ₄	i	l ₁ ≈	m ₃ ≈	m ₄	n ₁	n ₂	n ₃ ≈	n ₄	s ₂	w	x	
100-315/1504 ³⁾⁴⁾	160L	x		125	100	140	225	255	70	350	325	15		315	237	160	354	932	314	254				320	254	21	246	140
100-315/1854 ⁴⁾	180M	x	x	125	100	140	225	255	80	350	370	15		315	237	180	367	996	320	241				360	279	23	246	140
100-315/2204 ⁴⁾	180L	x	x	125	100	140	225	255	80	350	370	15		315	237	180	367	996	358	279				360	279	23	246	140
125-200/754 ³⁾⁴⁾	132M	x		150	125	140	195	244	59	300	298	12		315	216	132	302	774	240	178				270	216	15	213	140
125-200/1104 ³⁾⁴⁾	160M	x	x	150	125	140	195	244	70	350	325	15		315	216	160	354	932	300	210				320	254	21	246	140
125-200/1504 ³⁾⁴⁾	160L	x	x	150	125	140	195	244	70	350	325	15		315	216	160	354	932	314	254				320	254	21	246	140
125-200/1854 ⁴⁾	180M	x	x	150	125	140	195	244	80	350	370	15		315	216	180	367	996	320	241				360	279	23	246	140
125-200/2204 ⁴⁾	180L	x	x	150	125	140	195	244	80	350	370	15		315	216	180	367	996	358	279				360	279	23	246	140
125-250/1104 ³⁾⁴⁾	160M	x		150	125	140	226	275	70	350	325	15		315	245	160	354	932	300	210				320	254	21	246	140
125-250/1504 ³⁾⁴⁾	160L	x	x	150	125	140	226	275	70	350	325	15		315	245	160	354	932	314	254				320	254	21	246	140
125-250/1854 ⁴⁾	180M	x	x	150	125	140	226	275	80	350	370	15		315	245	180	367	996	320	241				360	279	23	246	140
125-250/2204 ⁴⁾	180L	x	x	150	125	140	226	275	80	350	370	15		315	245	180	367	996	358	279				360	279	23	246	140
150-200/754 ³⁾⁴⁾	132M	x		200	150	160	238	315	59	300	298	12		400	275	132	302	794	240	178				270	216	15	213	140
150-200/1104 ³⁾⁴⁾	160M	x		200	150	160	238	315	70	350	325	15		400	275	160	354	952	300	210				320	254	21	246	140
150-200/1504 ³⁾⁴⁾	160L	x	x	200	150	160	238	315	70	350	325	15		400	275	160	354	952	314	254				320	254	21	246	140
150-200/1854 ⁴⁾	180M	x	x	200	150	160	238	315	80	350	370	15		400	275	180	367	1016	320	241				360	279	23	246	140
150-200/2204 ⁴⁾	180L	x	x	200	150	160	238	315	80	350	370	15		400	275	180	367	1016	358	279				360	279	23	246	140
150-250/1504 ³⁾⁴⁾	160L	x		200	150	160	228	298	70	350	325	15		400	260	160	354	952	314	254				320	254	21	246	140
150-250/1854 ⁴⁾	180M	x		200	150	160	228	298	80	350	370	15		400	260	180	367	1016	320	241				360	279	23	246	140
150-250/2204 ⁴⁾	180L	x	x	200	150	160	228	298	80	350	370	15		400	260	180	367	1016	358	279				360	279	23	246	140

1) Rc = ISO 7/1;

G = ISO 228/1

2) DN = EN 1092-2/DN../PN 16/21/JL1040/B

DN 200 = EN 1092-2/DN 200/PN 10/21/JL1040/B

3) при этих типоразмерах опорные лапы электродвигателя должны стоять на фундаменте толщиной 20 мм

 4) h₃ ≥ h₁ / h₃ ≥ h₄

Etabloc BN, SN, CN 32-125.1/... до 32-125/..., n = 2900 об/мин, n = 3500 об/мин

без опорной лапы электродвигателя
(до типоразмера электродвигателя 112 = 4 кВт)
с опорной лапой электродвигателя
(начиная с типоразмера электродвигателя 132 = 5,5 кВт)

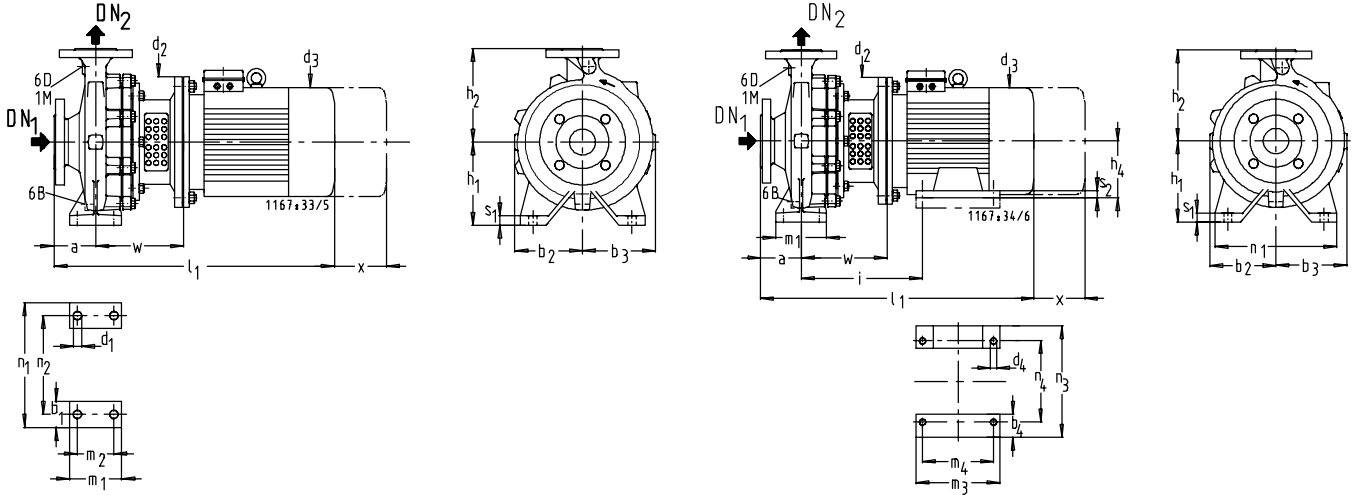

		Etabloc G, M		Etabloc SN, CN			
		Etabloc GN, MN, BN		DN ₂ 32 - DN ₂ 80		DN ₂ 100 - DN ₂ 150	
1 M	Присоединение манометра	Rc 3/8 ¹⁾	Rc 1/2 ¹⁾	G 3/8 ¹⁾	G 1/2 ¹⁾		
6 B	Перекачиваемая жидкость-Опорожнение	Rc 3/8 ¹⁾	Rc 1/2 ¹⁾	G 3/8 ¹⁾	G 1/2 ¹⁾		
6 D	Перекачиваемая жидкость-Заполнение и опорожнение	Rc 3/8 ¹⁾	Rc 1/2 ¹⁾	G 3/8 ¹⁾	G 1/2 ¹⁾		

Etabloc BN, SN, CN	M	n = 2900	n = 3500	Допуски присоединительных размеров по EN 735																											
				DN ₁ 2)	DN ₂ 2)	a	b ₁ ≈	b ₂ ≈	b ₃ ≈	b ₄ ≈	d ₁	d ₂	d ₃ ≈	d ₄	h ₁	h ₂	h ₄	i	l ₁ ≈	m ₁ ≈	m ₂	m ₃ ≈	m ₄	n ₁	n ₂	n ₃ ≈	n ₄	s ₁	s ₂	w	x
32-125.1/072	80	x		50	32	80	50	113	113	14	200	162	112	140			491	100	70					190	140			15		156	100
32-125.1/112	80	x	x	50	32	80	50	113	113	14	200	162	112	140			491	100	70					190	140			15		156	100
32-125.1/152	90S	x	x	50	32	80	50	113	113	14	200	190	112	140			518	100	70					190	140			15		156	100
32-125.1/222	90L	x	x	50	32	80	50	113	113	14	200	190	112	140			525	100	70					190	140			15		156	100
32-125.1/302	100L		x	50	32	80	50	113	113	14	250	213	112	140			563	100	70					190	140			15		170	100
32-125.1/402	112M		x	50	32	80	50	113	113	14	250	234	112	140			584	100	70					190	140			15		170	100
32-125.1/552 ³⁾	132S		x	50	32	80	50	113	113	55	14	300	266	12	112	140	132	282	672	100	70	220	140	190	140	270	216	15	15	193	100
32-160.1/152	90S	x		50	32	80	50	116	125	14	200	190	132	160			518	100	70					240	190			15		156	100
32-160.1/222	90L	x	x	50	32	80	50	116	125	14	200	190	132	160			525	100	70					240	190			15		156	100
32-160.1/302	100L	x	x	50	32	80	50	116	125	14	250	213	132	160			563	100	70					240	190			15		170	100
32-160.1/402	112M	x	x	50	32	80	50	116	125	14	250	234	132	160			584	100	70					240	190			15		170	100
32-160.1/552 ³⁾	132S		x	50	32	80	50	116	125	55	14	300	266	12	132	160	132	282	672	100	70	220	140	240	190	270	216	15	15	193	100
32-160.1/752 ³⁾	132S		x	50	32	80	50	116	125	55	14	300	266	12	132	160	132	282	672	100	70	220	140	240	190	270	216	15	15	193	100
32-200.1/302	100L	x		50	32	80	50	128	137	14	250	213	160	180			563	100	70					240	190			18		170	100
32-200.1/402	112M	x	x	50	32	80	50	128	137	14	250	234	160	180			584	100	70					240	190			18		170	100
32-200.1/552 ³⁾⁴⁾	132S	x	x	50	32	80	50	128	137	55	14	300	266	12	160	180	132	282	672	100	70	220	140	240	190	270	216	18	15	193	100
32-200.1/752 ³⁾⁴⁾	132S		x	50	32	80	50	128	137	55	14	300	266	12	160	180	132	282	672	100	70	220	140	240	190	270	216	18	15	193	100
32-200.1/1102 ³⁾⁴⁾	160M		x	50	32	80	50	128	137	70	14	350	325	15	160	180	160	334	852	100	70	300	210	240	190	320	254	18	21	226	100
32-200.1/1502 ³⁾⁴⁾	160M		x	50	32	80	50	128	137	70	14	350	325	15	160	180	160	334	852	100	70	300	210	240	190	320	254	18	21	226	100
32-250.1/552 ³⁾⁴⁾	132S	x		50	32	100	65	164	171	55	14	300	266	12	180	225	132	282	692	125	95	220	140	320	250	270	216	18	15	193	100
32-250.1/752 ³⁾⁴⁾	132S	x		50	32	100	65	164	171	55	14	300	266	12	180	225	132	282	692	125	95	220	140	320	250	270	216	18	15	193	100
32-250.1/1102 ³⁾⁴⁾	160M	x		50	32	100	65	164	171	70	14	350	325	15	180	225	160	334	872	125	95	300	210	320	250	320	254	18	21	226	100
32-250.1/1502 ³⁾⁴⁾	160M	x		50	32	100	65	164	171	70	14	350	325	15	180	225	160	334	872	125	95	300	210	320	250	320	254	18	21	226	100
32-125/112	80	x		50	32	80	50	113	113	14	200	162	112	140			491	100	70					190	140			15		156	100
32-125/152	90S	x	x	50	32	80	50	113	113	14	200	190	112	140			518	100	70					190	140			15		156	100
32-125/222	90L	x	x	50	32	80	50	113	113	14	200	190	112	140			525	100	70					190	140			15		156	100
32-125/302	100L	x	x	50	32	80	50	113	113	14	250	213	112	140			563	100	70					190	140			15		170	100
32-125/402	112M		x	50	32	80	50	113	113	14	250	234	112	140			584	100	70					190	140			15		170	100
32-125/552 ³⁾	132S		x	50	32	80	50	113	113	55	14	300	266	12	112	140	132	282	672	100	70	220	140	190	140	270	216	15	15	193	100

1) Rc = ISO 7/1; G = ISO 228/1

2) Etabloc BN: DN=ISO 7005-3/DN.../PN10/21; Etabloc SN: DN=EN 1092-2/DN.../PN16/21/JS1025/B; Etabloc CN: DN=EN 1092-1/DN.../PN16/21/B

3) при этих типоразмерах опорные лапы электродвигателя должны стоять на фундаменте толщиной 20 мм

4) Δ h₁ ≥ h₄

5) Фланцы DN₁ 65 / DN₂ 65 4 отверстия

Etabloc BN, SN, CN 32-160/... до 40-160/..., n = 2900 об/мин, n = 3500 об/мин

без опорной лапы электродвигателя
(до типоразмера электродвигателя 112 = 4 кВт)
с опорной лапой электродвигателя
(начиная с типоразмера электродвигателя 132 = 5,5 кВт)

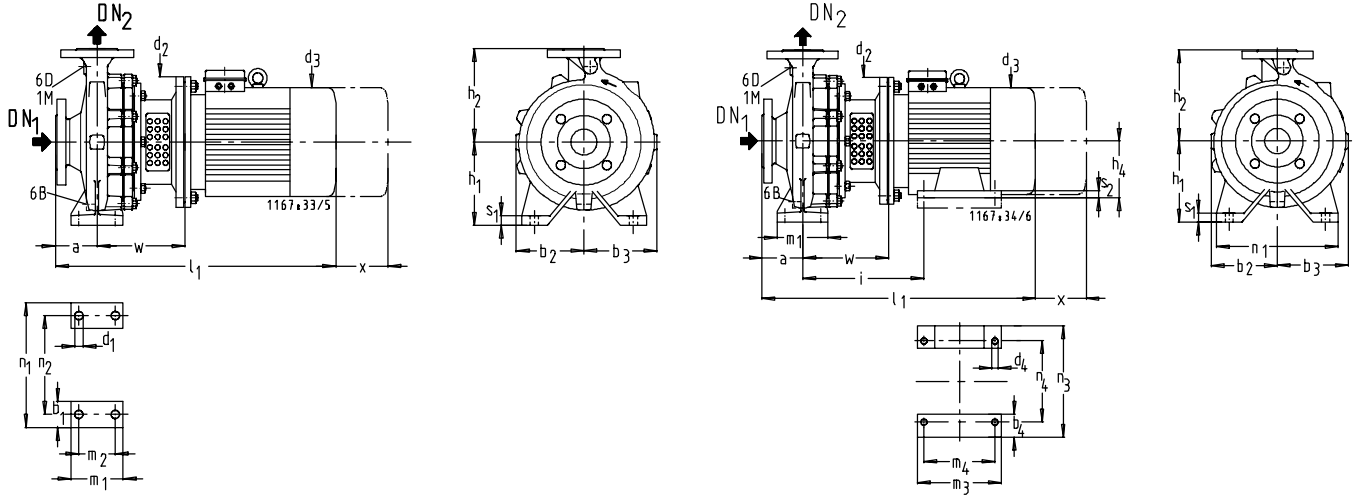

		Etabloc G, M		Etabloc SN, CN	
		Etabloc GN, MN, BN		DN ₂ 32 - DN ₂ 80	DN ₂ 100 - DN ₂ 150
1 M	Присоединение манометра	Rc 3/8 ¹⁾	Rc 1/2 ¹⁾	G 3/8 ¹⁾	G 1/2 ¹⁾
6 B	Перекачиваемая жидкость-Опорожнение	Rc 3/8 ¹⁾	Rc 1/2 ¹⁾	G 3/8 ¹⁾	G 1/2 ¹⁾
6 D	Перекачиваемая жидкость-Заполнение и опорожнение	Rc 3/8 ¹⁾	Rc 1/2 ¹⁾	G 3/8 ¹⁾	G 1/2 ¹⁾

Etabloc BN, SN, CN	M	n = 2900	n = 3500	Допуски присоединительных размеров по EN 735																											
				DN ₁ 2)	DN ₂ 2)	a	b ₁ ≈	b ₂ ≈	b ₃ ≈	b ₄ ≈	d ₁	d ₂	d ₃ ≈	d ₄	h ₁	h ₂	h ₄	i	l ₁ ≈	m ₁ ≈	m ₂	m ₃ ≈	m ₄	n ₁	n ₂	n ₃ ≈	n ₄	s ₁	s ₂	w	x
32-160/222	90L	x		50	32	80	50	113	125		14	200	190		132	160			525	100	70			240	190			15		156	100
32-160/302	100L	x	x	50	32	80	50	113	125		14	250	213		132	160			563	100	70			240	190			15		170	100
32-160/402	112M	x	x	50	32	80	50	113	125		14	250	234		132	160			584	100	70			240	190			15		170	100
32-160/552 ³⁾⁴⁾	132S		x	50	32	80	50	113	125	55	14	300	266	12	132	160	132	282	672	100	70	220	140	240	190	270	216	15	15	193	100
32-160/752 ³⁾⁴⁾	132S	x	x	50	32	80	50	113	125	55	14	300	266	12	132	160	132	282	672	100	70	220	140	240	190	270	216	15	15	193	100
32-200/402	112M	x		50	32	80	50	132	141		14	250	234		160	180			584	100	70			240	190			18		170	100
32-200/552 ³⁾⁴⁾	132S	x	x	50	32	80	50	132	141	55	14	300	266	12	160	180	132	282	672	100	70	220	140	240	190	270	216	18	15	193	100
32-200/752 ³⁾⁴⁾	132S	x	x	50	32	80	50	132	141	55	14	300	266	12	160	180	132	282	672	100	70	220	140	240	190	270	216	18	15	193	100
32-200/1102 ³⁾⁴⁾	160M	x	x	50	32	80	50	132	141	70	14	350	325	15	160	180	160	334	852	100	70	300	210	240	190	320	254	18	21	226	100
32-200/1502 ³⁾⁴⁾	160M		x	50	32	80	50	132	141	70	14	350	325	15	160	180	160	334	852	100	70	300	210	240	190	320	254	18	21	226	100
32-250/752 ³⁾⁴⁾	132S	x		50	32	100	65	170	176	55	14	300	266	12	180	225	132	282	692	125	95	220	140	320	250	270	216	18	15	193	100
32-250/1102 ³⁾⁴⁾	160M	x		50	32	100	65	170	176	70	14	350	325	15	180	225	160	334	872	125	95	300	210	320	250	320	254	18	21	226	100
32-250/1502 ³⁾⁴⁾	160M	x		50	32	100	65	170	176	70	14	350	325	15	180	225	160	334	872	125	95	300	210	320	250	320	254	18	21	226	100
40-125/152	90S	x		65 ⁵⁾	40	80	50	113	113		14	200	190		112	140			518	100	70			210	160			15		156	100
40-125/222	90L	x	x	65 ⁵⁾	40	80	50	113	113		14	200	190		112	140			525	100	70			210	160			15		156	100
40-125/302	100L	x	x	65 ⁵⁾	40	80	50	113	113		14	250	213		112	140			563	100	70			210	160			15		170	100
40-125/402	112M	x	x	65 ⁵⁾	40	80	50	113	113		14	250	234		112	140			584	100	70			210	160			15		170	100
40-125/552 ³⁾	132S		x	65 ⁵⁾	40	80	50	113	113	55	14	300	266	12	112	140	132	282	672	100	70	220	140	210	160	270	216	15	15	193	100
40-125/752 ³⁾	132S	x	x	65 ⁵⁾	40	80	50	113	113	55	14	300	266	12	112	140	132	282	672	100	70	220	140	210	160	270	216	15	15	193	100
40-125/1102 ³⁾	160M		x	65 ⁵⁾	40	80	50	113	113	70	14	350	325	15	112	140	160	334	852	100	70	300	210	210	160	320	254	15	21	226	100
40-160/302	100L	x		65 ⁵⁾	40	80	50	115	131		14	250	213		132	160			563	100	70			240	190			15		170	100
40-160/402	112M	x	x	65 ⁵⁾	40	80	50	115	131		14	250	234		132	160			584	100	70			240	190			15		170	100
40-160/552 ³⁾⁴⁾	132S	x	x	65 ⁵⁾	40	80	50	115	131	55	14	300	266	12	132	160	132	282	672	100	70	220	140	240	190	270	216	15	15	193	100
40-160/752 ³⁾⁴⁾	132S	x	x	65 ⁵⁾	40	80	50	115	131	55	14	300	266	12	132	160	132	282	672	100	70	220	140	240	190	270	216	15	15	193	100
40-160/1102 ³⁾	160M	x	x	65 ⁵⁾	40	80	50	115	131	70	14	350	325	15	132	160	160	334	852	100	70	300	210	240	190	320	254	15	21	226	100
40-160/1502 ³⁾	160M		x	65 ⁵⁾	40	80	50	115	131	70	14	350	325	15	132	160	160	334	852	100	70	300	210	240	190	320	254	15	21	226	100

1) Rc = ISO 7/1; G = ISO 228/1

2) Etabloc BN: DN=ISO 7005-3/DN.../PN10/21; Etabloc SN: DN=EN 1092-2/DN.../PN16/21/JS1025/B; Etabloc CN: DN=EN 1092-1/DN.../PN16/21/B

3) при этих типоразмерах опорные лапы электродвигателя должны стоять на фундаменте толщиной 20 мм

4) $h_1 \geq h_4$

5) Фланцы DN₁ 65 / DN₂ 65 4 отверстие

Etabloc BN, SN, CN 40-200/... до 50-250/..., n = 2900 об/мин, n = 3500 об/мин

без опорной лапы электродвигателя
(до типоразмера электродвигателя 112 = 4 кВт)
с опорной лапой электродвигателя
(начиная с типоразмера электродвигателя 132 = 5,5 кВт)

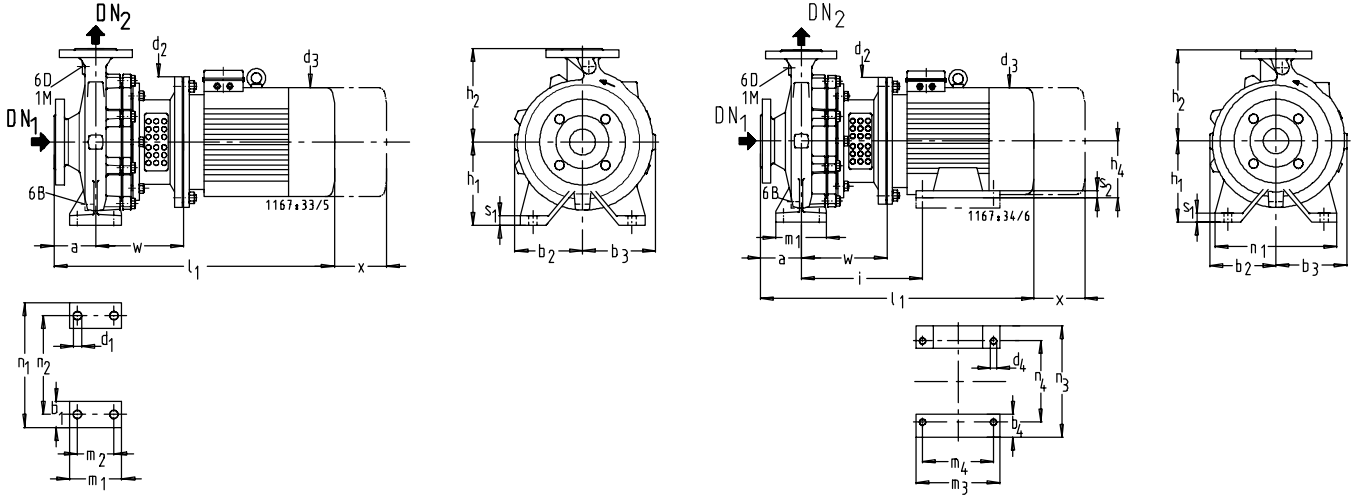

		Etabloc G, M		Etabloc SN, CN	
		Etabloc GN, MN, BN			
		DN2 32 - DN2 80	DN 2100	DN2 32 - DN2 80	DN2 100 - DN2 150
1 M	Присоединение манометра	Rc 3/8 1)	Rc 1/2 1)	G 3/8 1)	G 1/2 1)
6 B	Перекачиваемая жидкость-Опорожнение	Rc 3/8 1)	Rc 1/2 1)	G 3/8 1)	G 1/2 1)
6 D	Перекачиваемая жидкость-Заполнение и опорожнение	Rc 3/8 1)	Rc 1/2 1)	G 3/8 1)	G 1/2 1)

Etabloc BN, SN, CN	M	n = 2900	n = 3500	Допуски присоединительных размеров по EN 735																											
				DN 21	DN 22	a	b1 ≈	b2 ≈	b3 ≈	b4 ≈	d1	d2	d3 ≈	d4	h1	h2	h4	i	l1 ≈	m1 ≈	m2	m3 ≈	m4	n1	n2	n3 ≈	n4	s1	s2	w	x
40-200/552 3)4)	132S	x		65 5)	40	100	50	140	152	55	14	300	266	12	160	180	132	282	692	100	70	220	140	265	212	270	216	18	15	193	100
40-200/752 3)4)	132S	x	x	65 5)	40	100	50	140	152	55	14	300	266	12	160	180	132	282	692	100	70	220	140	265	212	270	216	18	15	193	100
40-200/1102 3)4)	160M	x	x	65 5)	40	100	50	140	152	70	14	350	325	15	160	180	160	334	872	100	70	300	210	265	212	320	254	18	21	226	100
40-200/1502 3)4)	160M	x	x	65 5)	40	100	50	140	152	70	14	350	325	15	160	180	160	334	872	100	70	300	210	265	212	320	254	18	21	226	100
40-200/1852 3)4)	160L		x	65 5)	40	100	50	140	152	70	14	350	325	15	160	180	160	334	872	100	70	314	254	265	212	320	254	18	21	226	100
40-200/2202	180M		x	65 5)	40	100	50	140	152	80	14	350	370	15	160	180	180	347	936	100	70	320	241	265	212	360	279	18	23	226	100
40-250/1102	160M	x		65 5)	40	100	65	165	178	70	14	350	325	15	180	225	160	334	872	125	95	300	210	320	250	320	254	18	21	226	100
40-250/1502	160M	x		65 5)	40	100	65	165	178	70	14	350	325	15	180	225	160	334	872	125	95	300	210	320	250	320	254	18	21	226	100
40-250/1852	160L	x		65 5)	40	100	65	165	178	70	14	350	325	15	180	225	160	334	872	125	95	314	254	320	250	320	254	18	21	226	100
40-250/2202	180M	x		65 5)	40	100	65	165	178	80	14	350	370	15	180	225	180	347	936	125	95	320	241	320	250	360	279	18	23	226	100
50-125/302	100L	x		65 5)	50	100	50	113	128		14	250	213		132	160				583	100	70			240	190			18	170	100
50-125/402	112M	x		65 5)	50	100	50	113	128		14	250	234		132	160				604	100	70			240	190			18	170	100
50-125/552 3)4)	132S	x	x	65 5)	50	100	50	113	128	55	14	300	266	12	132	160	132	282	692	100	70	220	140	240	190	270	216	18	15	193	100
50-125/752 3)4)	132S	x	x	65 5)	50	100	50	113	128	55	14	300	266	12	132	160	132	282	692	100	70	220	140	240	190	270	216	18	15	193	100
50-125/1102 3)	160M		x	65 5)	50	100	50	113	128	70	14	350	325	15	132	160	160	334	872	100	70	300	210	240	190	320	254	18	21	226	100
50-125/1502 3)	160M		x	65 5)	50	100	50	113	128	70	14	350	325	15	132	160	160	334	872	100	70	300	210	240	190	320	254	18	21	226	100
50-160/552 3)4)	132S	x	x	65 5)	50	100	50	126	147	55	14	300	266	12	160	180	132	282	692	100	70	220	140	265	212	270	216	18	15	193	100
50-160/752 3)4)	132S	x	x	65 5)	50	100	50	126	147	55	14	300	266	12	160	180	132	282	692	100	70	220	140	265	212	270	216	18	15	193	100
50-160/1102 3)4)	160M	x	x	65 5)	50	100	50	126	147	70	14	350	325	15	160	180	160	334	872	100	70	300	210	265	212	320	254	18	21	226	100
50-160/1502 3)4)	160M	x	x	65 5)	50	100	50	126	147	70	14	350	325	15	160	180	160	334	872	100	70	300	210	265	212	320	254	18	21	226	100
50-160/1852 3)4)	160L		x	65 5)	50	100	50	126	147	70	14	350	325	15	160	180	160	334	872	100	70	314	254	265	212	320	254	18	21	226	100
50-160/2202	180M		x	65 5)	50	100	50	126	147	80	14	350	370	15	160	180	180	347	936	100	70	320	241	265	212	360	279	18	23	226	100
50-200/1102 3)4)	160M	x	x	65 5)	50	100	50	145	165	70	14	350	325	15	160	200	160	334	872	100	70	300	210	265	212	320	254	18	21	226	100
50-200/1502 3)4)	160M	x	x	65 5)	50	100	50	145	165	70	14	350	325	15	160	200	160	334	872	100	70	300	210	265	212	320	254	18	21	226	100
50-200/1852 3)4)	160L	x	x	65 5)	50	100	50	145	165	70	14	350	325	15	160	200	160	334	872	100	70	314	254	265	212	320	254	18	21	226	100
50-200/2202	180M	x	x	65 5)	50	100	50	145	165	80	14	350	370	15	160	200	180	347	936	100	70	320	241	265	212	360	279	18	23	226	100
50-250/1502 3)4)	160M	x		65 5)	50	100	65	168	184	70	14	350	325	15	180	225	160	334	872	125	95	300	210	320	250	320	254	18	21	226	100
50-250/1852 3)4)	160L	x		65 5)	50	100	65	168	184	70	14	350	325	15	180	225	160	334	872	125	95	314	254	320	250	320	254	18	21	226	100
50-250/2202 4)	180M	x		65 5)	50	100	65	168	184	80	14	350	370	15	180	225	180	347	936	125	95	320	241	320	250	360	279	18	23	226	100
50-250/3002	200L	x		65 5)	50	100	65	168	184	85	14	400	422	19	180	225	200	359	995	125	95	388	305	320	250	400	318	18	30	226	100
50-250/3702	200L	x		65 5)	50	100	65	168	184	85	14	400	422	19	180	225	200	359	995	125	95	388	305	320	250	400	318	18	30	226	100

1) Rc = ISO 7/1; G = ISO 228/1
 2) Etabloc BN: DN=ISO 7005-3/DN.../PN10/21; Etabloc SN: DN=EN 1092-2/DN.../PN16/21/JS1025/B; Etabloc CN: DN=EN 1092-1/DN.../PN16/21/B
 3) при этих типоразмерах опорные лапы электродвигателя должны стоять на фундаменте толщиной 20 мм
 4) $h_1 \geq h_4$
 5) Фланцы DN1 65 / DN2 65 4 отверстия

Etabloc BN, SN, CN 65-125/... до 65-250/..., n = 2900 об/мин, n = 3500 об/мин

без опорной лапы электродвигателя
(до типоразмера электродвигателя 112 = 4 кВт)
с опорной лапой электродвигателя
(начиная с типоразмера электродвигателя 132 = 5,5 кВт)

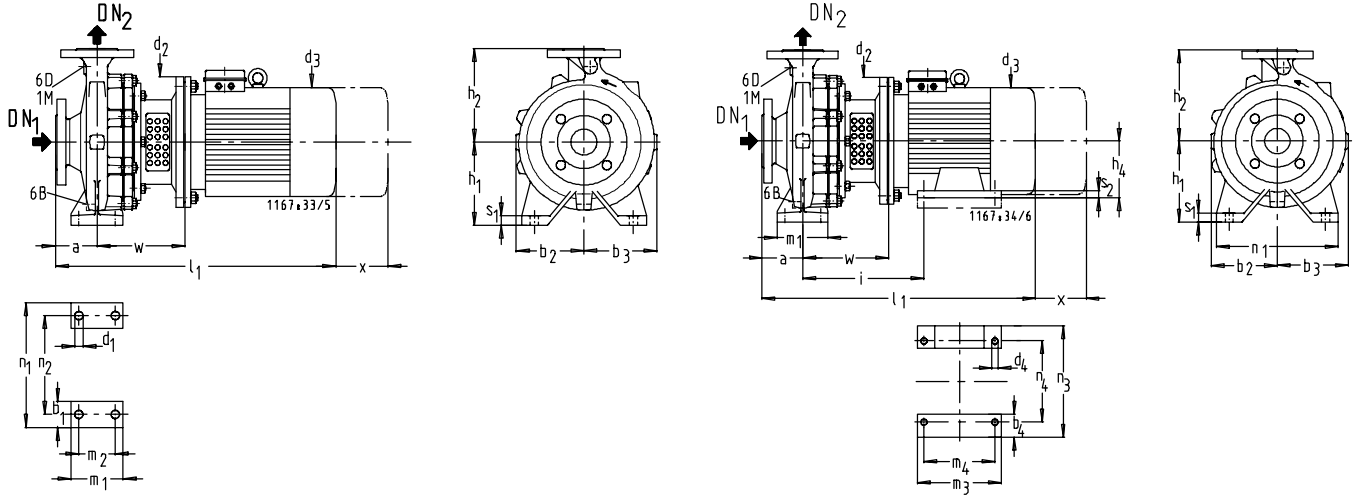

		Etabloc G, M		Etabloc SN, CN	
		Etabloc GN, MN, BN		DN ₂ 32 - DN ₂ 80	DN ₂ 100 - DN ₂ 150
1 M	Присоединение манометра	Rc 3/8 ¹⁾	Rc 1/2 ¹⁾	G 3/8 ¹⁾	G 1/2 ¹⁾
6 B	Перекачиваемая жидкость-Опорожнение	Rc 3/8 ¹⁾	Rc 1/2 ¹⁾	G 3/8 ¹⁾	G 1/2 ¹⁾
6 D	Перекачиваемая жидкость-Заполнение и опорожнение	Rc 3/8 ¹⁾	Rc 1/2 ¹⁾	G 3/8 ¹⁾	G 1/2 ¹⁾

Etabloc BN, SN, CN	M	n = 2900	n = 3500	Допуски присоединительных размеров по EN 735																											
				DN ₁	DN ₂	a	b ₁	b ₂	b ₃	b ₄	d ₁	d ₂	d ₃	d ₄	h ₁	h ₂	h ₄	i	l ₁	m ₁	m ₂	m ₃	m ₄	n ₁	n ₂	n ₃	n ₄	s ₁	s ₂	w	x
65-125/402	112M	x		80	65 ⁵⁾	100	65	120	148	55	14	250	234	12	160	180			604	125	95	220	140	280	212	270	216	18	15	193	100
65-125/552 ³⁾⁴⁾	132S	x	x	80	65 ⁵⁾	100	65	120	148	55	14	300	266	12	160	180	132	282	692	125	95	220	140	280	212	270	216	18	15	193	100
65-125/752 ³⁾⁴⁾	132S	x	x	80	65 ⁵⁾	100	65	120	148	55	14	300	266	12	160	180	132	282	692	125	95	220	140	280	212	270	216	18	15	193	100
65-125/1102 ³⁾⁴⁾	160M	x	x	80	65 ⁵⁾	100	65	120	148	70	14	350	325	15	160	180	160	334	872	125	95	300	210	280	212	320	254	18	21	226	100
65-125/1502 ³⁾⁴⁾	160M		x	80	65 ⁵⁾	100	65	120	148	70	14	350	325	15	160	180	160	334	872	125	95	300	210	280	212	320	254	18	21	226	100
65-160/752 ³⁾⁴⁾	132S	x		80	65 ⁵⁾	100	65	130	158	55	14	300	266	12	160	200	132	282	692	125	95	220	140	280	212	270	216	18	15	193	100
65-160/1102 ³⁾⁴⁾	160M	x	x	80	65 ⁵⁾	100	65	130	158	70	14	350	325	15	160	200	160	334	872	125	95	300	210	280	212	320	254	18	21	226	100
65-160/1502 ³⁾⁴⁾	160M	x	x	80	65 ⁵⁾	100	65	130	158	70	14	350	325	15	160	200	160	334	872	125	95	300	210	280	212	320	254	18	21	226	100
65-160/1852 ³⁾⁴⁾	160L		x	80	65 ⁵⁾	100	65	130	158	70	14	350	325	15	160	200	160	334	872	125	95	314	254	280	212	320	254	18	21	226	100
65-160/2202	180M		x	80	65 ⁵⁾	100	65	130	158	80	14	350	370	15	160	200	180	347	936	125	95	320	241	280	212	360	279	18	23	226	100
65-160/3002	200L		x	80	65 ⁵⁾	100	65	130	158	85	14	400	422	19	160	200	200	359	995	125	95	388	305	280	212	400	318	18	30	226	100
65-200/1502 ³⁾⁴⁾	160M	x		80	65 ⁵⁾	100	65	154	177	70	14	350	325	15	180	225	160	334	872	125	95	300	210	320	250	320	254	18	21	226	140
65-200/1852 ³⁾⁴⁾	160L	x	x	80	65 ⁵⁾	100	65	154	177	70	14	350	325	15	180	225	160	334	872	125	95	314	254	320	250	320	254	18	21	226	140
65-200/2202 ⁴⁾	180M	x	x	80	65 ⁵⁾	100	65	154	177	80	14	350	370	15	180	225	180	347	936	125	95	320	241	320	250	360	279	18	23	226	140
65-200/3002	200L		x	80	65 ⁵⁾	100	65	154	177	85	14	400	422	19	180	225	200	359	995	125	95	388	305	320	250	400	318	18	30	226	140
65-250/2202 ⁴⁾	180M	x		80	65 ⁵⁾	100	80	180	200	80	18	350	370	15	200	250	180	367	956	160	120	320	241	360	280	360	279	20	23	246	140
65-250/3002 ⁴⁾	200L	x		80	65 ⁵⁾	100	80	180	200	85	18	400	422	19	200	250	200	379	1015	160	120	388	305	360	280	400	318	20	30	246	140
65-250/3702 ⁴⁾	200L	x		80	65 ⁵⁾	100	80	180	200	85	18	400	422	19	200	250	200	379	1015	160	120	388	305	360	280	400	318	20	30	246	140
65-250/4502	225M	x		80	65	100	80	180	200	100	18	450	468	19	200	250	225	419	1092	160	120	410	311	360	280	450	356	20	35	270	140

1) Rc = ISO 7/1; G = ISO 228/1

2) Etabloc BN: DN=ISO 7005-3/DN.../PN10/21; Etabloc SN: DN=EN 1092-2/DN.../PN16/21/JS1025/B; Etabloc CN: DN=EN 1092-1/DN.../PN16/21/B

3) при этих типоразмерах опорные лапы электродвигателя должны стоять на фундаменте толщиной 20 мм

4) Δ h₁ ≥ h₄

5) Фланцы DN₁ 65 / DN₂ 65 4 отверстия

Etabloc BN, SN, CN 80-160/... до 100-200/..., n = 2900 об/мин, n = 3500 об/мин

без опорной лапы электродвигателя
(до типоразмера электродвигателя 112 = 4 кВт)
с опорной лапой электродвигателя
(начиная с типоразмера электродвигателя 132 = 5,5 кВт)

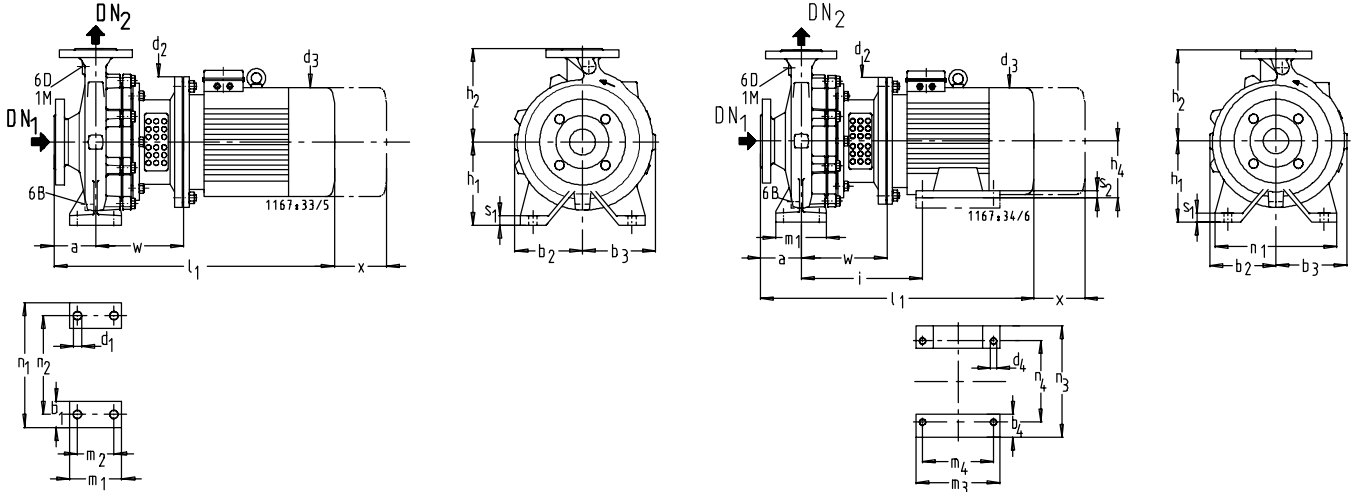

		Etabloc G, M		Etabloc SN, CN	
		Etabloc GN, MN, BN		DN ₂ 32 - DN ₂ 80	DN ₂ 100 - DN ₂ 150
1 M	Присоединение манометра	Rc 3/8 ¹⁾	Rc 1/2 ¹⁾	G 3/8 ¹⁾	G 1/2 ¹⁾
6 B	Перекачиваемая жидкость-Опорожнение	Rc 3/8 ¹⁾	Rc 1/2 ¹⁾	G 3/8 ¹⁾	G 1/2 ¹⁾
6 D	Перекачиваемая жидкость-Заполнение и опорожнение	Rc 3/8 ¹⁾	Rc 1/2 ¹⁾	G 3/8 ¹⁾	G 1/2 ¹⁾

Etabloc BN, SN, CN	M	n = 2900	n = 3500	Допуски присоединительных размеров по EN 735																											
				DN ₁	DN ₂	a	b ₁	b ₂	b ₃	b ₄	d ₁	d ₂	d ₃	d ₄	h ₁	h ₂	h ₄	i	l ₁	m ₁	m ₂	m ₃	m ₄	n ₁	n ₂	n ₃	n ₄	s ₁	s ₂	w	x
80-160/1102 ³⁾⁴⁾	160M	x		100	80	125	65	153	192	70	14	350	325	15	180	225	160	334	897	125	95	300	210	320	250	320	254	18	21	226	140
80-160/1502 ³⁾⁴⁾	160M	x		100	80	125	65	153	192	70	14	350	325	15	180	225	160	334	897	125	95	300	210	320	250	320	254	18	21	226	140
80-160/1852 ³⁾⁴⁾	160L	x		100	80	125	65	153	192	70	14	350	325	15	180	225	160	334	897	125	95	314	254	320	250	320	254	18	21	226	140
80-160/2202 ⁴⁾	180M	x	x	100	80	125	65	153	192	80	14	350	370	15	180	225	180	347	961	125	95	320	241	320	250	360	279	18	23	226	140
80-160/3002	200L	x	x	100	80	125	65	153	192	85	14	400	422	19	180	225	200	359	1020	125	95	388	305	320	250	400	318	18	30	226	140
80-160/3702	200L	x	x	100	80	125	65	153	192	85	14	400	422	19	180	225	200	359	1020	125	95	388	305	320	250	400	318	18	30	226	140
80-200/1852 ³⁾⁴⁾	160L	x		100	80	125	65	161	189	70	14	350	325	15	180	250	160	354	917	125	95	314	254	345	280	320	254	18	21	246	140
80-200/2202 ⁴⁾	180M	x		100	80	125	65	161	189	80	14	350	370	15	180	250	180	367	981	125	95	320	241	345	280	360	279	18	23	246	140
80-200/3002	200L	x		100	80	125	65	161	189	85	14	400	422	19	180	250	200	379	1040	125	95	388	305	345	280	400	318	18	30	246	140
80-200/3702	200L	x		100	80	125	65	161	189	85	14	400	422	19	180	250	200	379	1040	125	95	388	305	345	280	400	318	18	30	246	140
80-200/4502	225M	x	x	100	80	125	65	161	189	100	14	450	468	19	180	250	225	419	1117	125	95	410	311	345	280	450	356	18	35	270	140
80-250/3002 ⁴⁾	200L	x		100	80	125	80	184	210	85	18	400	422	19	200	280	200	379	1040	160	120	388	305	400	315	400	318	18	30	246	140
80-250/3702 ⁴⁾	200L	x		100	80	125	80	184	210	85	18	400	422	19	200	280	200	379	1040	160	120	388	305	400	315	400	318	18	30	246	140
80-250/4502	225M	x		100	80	125	80	184	210	100	18	450	468	19	200	280	225	419	1117	160	120	410	311	400	315	450	356	18	35	270	140
100-160/2202	180M	x		125	100	125	80	178	225	80	18	350	370	15	200	280	180	367	981	160	120	320	241	360	280	360	279	18	23	246	140
100-160/3002 ⁴⁾	200L	x		125	100	125	80	178	225	85	18	400	422	19	200	280	200	379	1040	160	120	388	305	360	280	400	318	18	30	246	140
100-160/3702 ⁴⁾	200L	x	x	125	100	125	80	178	225	85	18	400	422	19	200	280	200	379	1040	160	120	388	305	360	280	400	318	18	30	246	140
100-160/4502	225M		x	125	100	125	80	178	225	100	18	450	468	19	200	280	225	419	1117	160	120	410	311	360	280	450	356	18	35	270	140
100-200/3002 ⁴⁾	200L	x		125	100	125	80	173	213	85	18	400	422	19	200	280	200	379	1040	160	120	388	305	360	280	400	318	18	30	246	140
100-200/3702 ⁴⁾	200L	x		125	100	125	80	173	213	85	18	400	422	19	200	280	200	379	1040	160	120	388	305	360	280	400	318	18	30	246	140
100-200/4502	225M	x		125	100	125	80	173	213	100	18	450	468	19	200	280	225	419	1117	160	120	410	311	360	280	450	356	18	35	270	140

1) Rc = ISO 7/1; G = ISO 228/1
2) Etabloc BN: DN=ISO 7005-3/DN.../PN10/21; Etabloc SN: DN=EN 1092-2/DN.../PN16/21/JS1025/B; Etabloc CN: DN=EN 1092-1/DN.../PN16/21/B
3) При этих типоразмерах опорные лапы электродвигателя должны стоять на фундаменте толщиной 20 мм

4) $h_1 \geq h_4$
5) Фланцы DN₁ 65 / DN₂ 65 4 отверстия

Etabloc BN, SN, CN 32-125,1/... до 32-200/..., n = 1450 об/мин, n = 1750 об/мин

без опорной лапы электродвигателя
(до типоразмера электродвигателя 112 = 4 кВт)
с опорной лапой электродвигателя
(начиная с типоразмера электродвигателя 132 = 5,5 кВт)

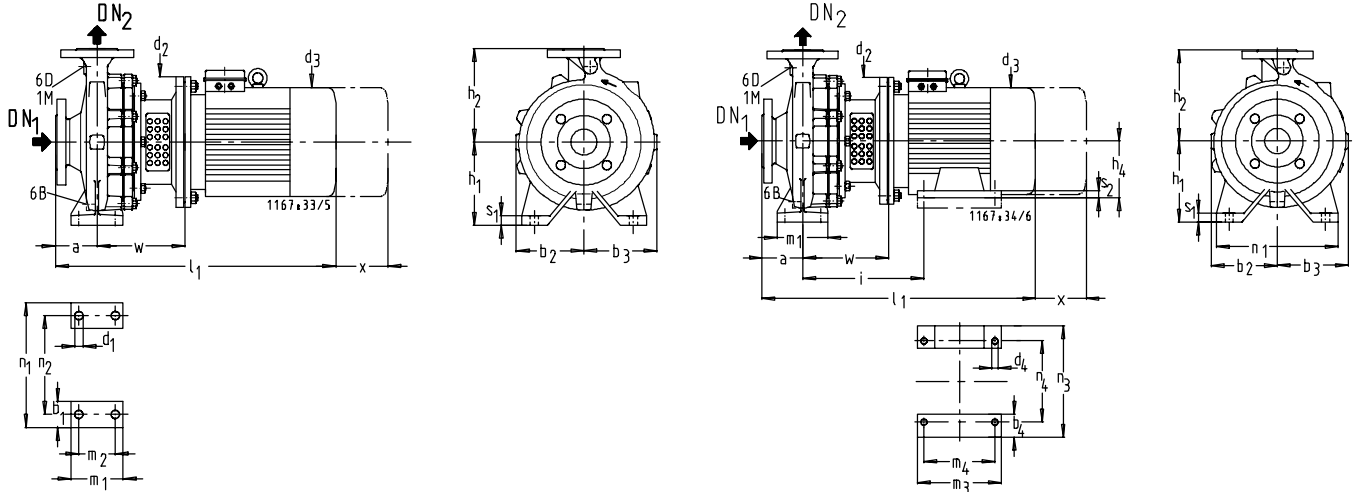

		Etabloc G, M		Etabloc SN, CN	
		Etabloc GN, MN, BN		DN ₂ 32 - DN ₂ 80	DN ₂ 100 - DN ₂ 150
1 M	Присоединение манометра	Rc 3/8 ¹⁾	Rc 1/2 ¹⁾	G 3/8 ¹⁾	G 1/2 ¹⁾
6 B	Перекачиваемая жидкость-Опорожнение	Rc 3/8 ¹⁾	Rc 1/2 ¹⁾	G 3/8 ¹⁾	G 1/2 ¹⁾
6 D	Перекачиваемая жидкость-Заполнение и опорожнение	Rc 3/8 ¹⁾	Rc 1/2 ¹⁾	G 3/8 ¹⁾	G 1/2 ¹⁾

Etabloc BN, SN, CN	M	n = 1450	n = 1750	Допуски присоединительных размеров по EN 735																										
				DN ₁ 2)	DN ₂ 2)	a	b ₁ ≈	b ₂ ≈	b ₃ ≈	b ₄ ≈	d ₁	d ₂	d ₃ ≈	d ₄	h ₁	h ₂	h ₄	i	l ₁ ≈	m ₁ ≈	m ₂	m ₃ ≈	m ₄	n ₁	n ₂	n ₃ ≈	n ₄	s ₁	s ₂	w
32-125.1/024	71	x	x	50	32	80	50	113	113	14	160	145	112	140				437	100	70				190	140			15	136	100
32-125.1/034	71	x	x	50	32	80	50	113	113	14	160	145	112	140				437	100	70				190	140			15	136	100
32-125.1/054	80	x	x	50	32	80	50	113	113	14	200	162	112	140				491	100	70				190	140			15	156	100
32-160.1/034	71	x	x	50	32	80	50	116	125	14	160	145	132	160				437	100	70				240	190			15	136	100
32-160.1/054	80	x	x	50	32	80	50	116	125	14	200	162	132	160				491	100	70				240	190			15	156	100
32-160.1/074	80		x	50	32	80	50	116	125	14	200	162	132	160				491	100	70				240	190			15	156	100
32-160.1/114	90S		x	50	32	80	50	116	125	14	200	190	132	160				518	100	70				240	190			15	156	100
32-200.1/054	80	x	x	50	32	80	50	128	137	14	200	162	160	180				491	100	70				240	190			18	156	100
32-200.1/074	80	x	x	50	32	80	50	128	137	14	200	162	160	180				491	100	70				240	190			18	156	100
32-200.1/114	90S		x	50	32	80	50	128	137	14	200	190	160	180				518	100	70				240	190			18	156	100
32-200.1/154	90L		x	50	32	80	50	128	137	14	200	190	160	180				525	100	70				240	190			18	156	100
32-200.1/224	100L		x	50	32	80	50	128	137	14	250	213	160	180				563	100	70				240	190			18	170	100
32-250.1/074	80	x		50	32	100	65	164	171	14	200	162	180	225				511	125	95				320	250			18	156	100
32-250.1/114	90S	x	x	50	32	100	65	164	171	14	200	190	180	225				538	125	95				320	250			18	156	100
32-250.1/154	90L	x	x	50	32	100	65	164	171	14	200	190	180	225				545	125	95				320	250			18	156	100
32-250.1/224	100L		x	50	32	100	65	164	171	14	250	213	180	225				583	125	95				320	250			18	170	100
32-250.1/304	100L		x	50	32	100	65	164	171	14	250	213	180	225				583	125	95				320	250			18	170	100
32-125/034	71	x	x	50	32	80	50	113	113	14	160	145	112	140				437	100	70				190	140			15	136	100
32-125/054	80	x	x	50	32	80	50	113	113	14	200	162	112	140				491	100	70				190	140			15	156	100
32-125/074	80		x	50	32	80	50	113	113	14	200	162	112	140				491	100	70				190	140			15	156	100
32-160/054	80	x	x	50	32	80	50	113	125	14	200	162	132	160				491	100	70				240	190			15	156	100
32-160/074	80		x	50	32	80	50	113	125	14	200	162	132	160				491	100	70				240	190			15	156	100
32-160/114	90S		x	50	32	80	50	113	125	14	200	190	132	160				518	100	70				240	190			15	156	100
32-200/054	80	x		50	32	80	50	132	141	14	200	162	160	180				491	100	70				240	190			18	156	100
32-200/074	80	x	x	50	32	80	50	132	141	14	200	162	160	180				491	100	70				240	190			18	156	100
32-200/114	90S	x	x	50	32	80	50	132	141	14	200	190	160	180				518	100	70				240	190			18	156	100
32-200/154	90L		x	50	32	80	50	132	141	14	200	190	160	180				525	100	70				240	190			18	156	100
32-200/224	100L		x	50	32	80	50	132	141	14	250	213	160	180				563	100	70				240	190			18	170	100

1) Rc = ISO 7/1; G = ISO 228/1

2) Etabloc BN: DN=ISO 7005-3/DN.../PN10/21; Etabloc SN: DN=EN 1092-2/DN.../PN16/21/JS1025/B; Etabloc CN: DN=EN 1092-1/DN.../PN16/21/B / DN200=EN 1092-1/DN200/PN10/21/B

3) При этих типоразмерах опорные лапы электродвигателя должны стоять на фундаменте толщиной 20 мм

4) $h_1 \geq h_4$

5) Фланцы DN₁ 65 / DN₂ 65 4 отверстия

Etabloc BN, SN, CN 32-250/... до 40-250/..., n = 1450 об/мин, n = 1750 об/мин

без опорной лапы электродвигателя
(до типоразмера электродвигателя 112 = 4 кВт)
с опорной лапой электродвигателя
(начиная с типоразмера электродвигателя 132 = 5,5 кВт)

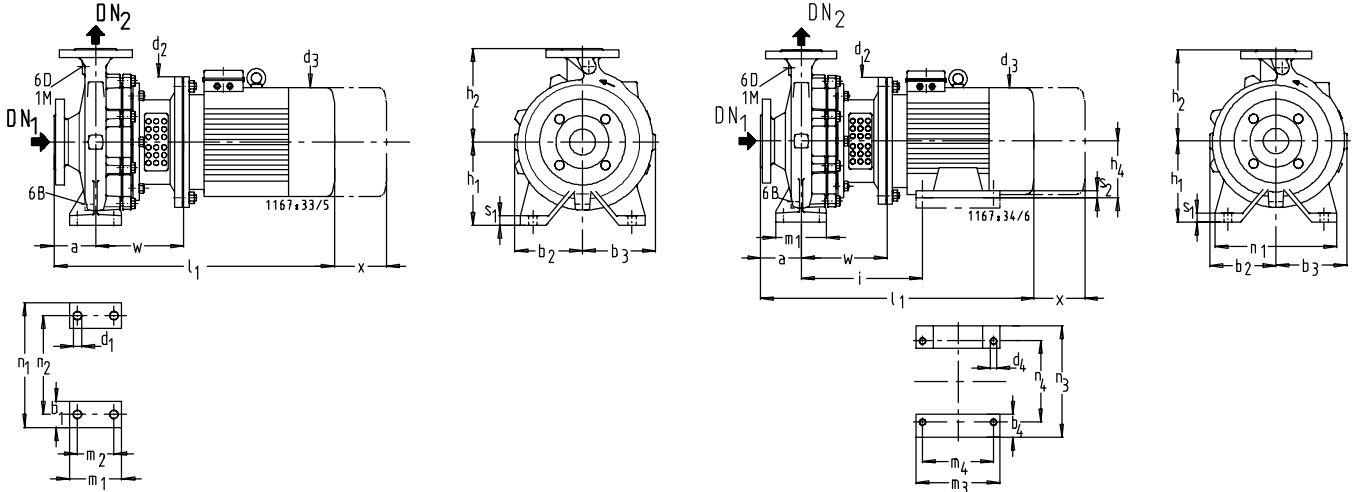

		Etabloc G, M		Etabloc SN, CN	
		Etabloc GN, MN, BN		DN ₂ 32 - DN ₂ 80	DN ₂ 100 - DN ₂ 150
1 M	Присоединение манометра	Rc 3/8 ¹⁾	Rc 1/2 ¹⁾	G 3/8 ¹⁾	G 1/2 ¹⁾
6 B	Перекачиваемая жидкость-Опорожнение	Rc 3/8 ¹⁾	Rc 1/2 ¹⁾	G 3/8 ¹⁾	G 1/2 ¹⁾
6 D	Перекачиваемая жидкость-Заполнение и опорожнение	Rc 3/8 ¹⁾	Rc 1/2 ¹⁾	G 3/8 ¹⁾	G 1/2 ¹⁾

Etabloc BN, SN, CN	M	n = 1450	n = 1750	Допуски присоединительных размеров по EN 735																											
				DN ₂ 1	DN ₂ 2	a	b ₁	b ₂	b ₃	b ₄	d ₁	d ₂	d ₃	d ₄	h ₁	h ₂	h ₄	i	l ₁	m ₁	m ₂	m ₃	m ₄	n ₁	n ₂	n ₃	n ₄	s ₁	s ₂	w	x
32-250/114	90S	x		50	32	100	65	170	176		14	200	190		180	225		538	125	95			320	250				18		156	100
32-250/154	90L	x		50	32	100	65	170	176		14	250	213		180	225		583	125	95			320	250				18		170	100
32-250/224	100L	x	x	50	32	100	65	170	176		14	250	213		180	225		583	125	95			320	250				18		170	100
32-250/304	100L		x	50	32	100	65	170	176		14	250	213		180	225		583	125	95			320	250				18		170	100
32-250/404	112M		x	50	32	100	65	170	176		14	250	234		180	225		604	125	95			320	250				18		170	100
32-250/554 ³⁾⁴⁾	132S		x	50	32	100	65	170	176	55	14	300	266	12	180	225	132	282	692	125	95	220	140	320	250	270	216	18	15	193	100
40-125/024	71	x		65 ⁵⁾	40	80	50	113	113		14	160	145		112	140		437	100	70			210	160				15		136	100
40-125/034	71	x		65 ⁵⁾	40	80	50	113	113		14	160	145		112	140		437	100	70			210	160				15		136	100
40-125/054	80	x	x	65 ⁵⁾	40	80	50	113	113		14	200	162		112	140		491	100	70			210	160				15		156	100
40-125/074	80		x	65 ⁵⁾	40	80	50	113	113		14	200	162		112	140		491	100	70			210	160				15		156	100
40-125/114	90S		x	65 ⁵⁾	40	80	50	113	113		14	200	190		112	140		518	100	70			210	160				15		156	100
40-160/054	80	x		65 ⁵⁾	40	80	50	115	131		14	200	162		132	160		491	100	70			240	190				15		156	100
40-160/074	80	x	x	65 ⁵⁾	40	80	50	115	131		14	200	162		132	160		491	100	70			240	190				15		156	100
40-160/114	90S	x	x	65 ⁵⁾	40	80	50	115	131		14	200	190		132	160		518	100	70			240	190				15		156	100
40-160/154	90L		x	65 ⁵⁾	40	80	50	115	131		14	200	190		132	160		525	100	70			240	190				15		156	100
40-160/224	100L		x	65 ⁵⁾	40	80	50	115	131		14	250	213		132	160		563	100	70			240	190				15		170	100
40-200/074	80	x		65 ⁵⁾	40	100	50	140	152		14	200	162		160	180		511	100	70			265	212				18		156	100
40-200/114	90S	x		65 ⁵⁾	40	100	50	140	152		14	200	190		160	180		538	100	70			265	212				18		156	100
40-200/154	90L	x	x	65 ⁵⁾	40	100	50	140	152		14	200	190		160	180		545	100	70			265	212				18		156	100
40-200/224	100L		x	65 ⁵⁾	40	100	50	140	152		14	250	213		160	180		583	100	70			265	212				18		170	100
40-200/304	100L		x	65 ⁵⁾	40	100	50	140	152		14	250	213		160	180		583	100	70			265	212				18		170	100
40-250/114	90S	x		65 ⁵⁾	40	100	65	165	178		14	200	190		180	225		538	125	95			320	250				18		156	100
40-250/154	90L	x		65 ⁵⁾	40	100	65	165	178		14	200	190		180	225		545	125	95			320	250				18		156	100
40-250/224	100L	x	x	65 ⁵⁾	40	100	65	165	178		14	250	213		180	225		583	125	95			320	250				18		170	100
40-250/304	100L	x	x	65 ⁵⁾	40	100	65	165	178		14	250	213		180	225		583	125	95			320	250				18		170	100
40-250/404	112M		x	65 ⁵⁾	40	100	65	165	178		14	250	234		180	225		604	125	95			320	250				18		170	100
40-250/554 ³⁾⁴⁾	132S		x	65 ⁵⁾	40	100	65	165	178	55	14	300	266	12	180	225	132	282	692	125	95	220	140	320	250	270	216	18	15	193	100

1) Rc = ISO 7/1; G = ISO 228/1
 2) Etabloc BN: DN=ISO 7005-3/DN.../PN10/21; Etabloc SN: DN=EN 1092-2/DN.../PN16/21/JS1025/B; Etabloc CN: DN=EN 1092-1/DN.../PN16/21/B / DN200=EN 1092-1/DN200/PN10/21/B
 3) при этих типоразмерах опорные лапы электродвигателя должны стоять на фундаменте толщиной 20 мм
 4) $h_1 \geq h_4$
 5) Фланцы DN₁ 65 / DN₂ 65 4 отверстия

Etabloc BN, SN, CN 40-315/... до 50-250/..., n = 1450 об/мин, n = 1750 об/мин

без опорной лапы электродвигателя
(до типоразмера электродвигателя 112 = 4 кВт)
с опорной лапой электродвигателя
(начиная с типоразмера электродвигателя 132 = 5,5 кВт)

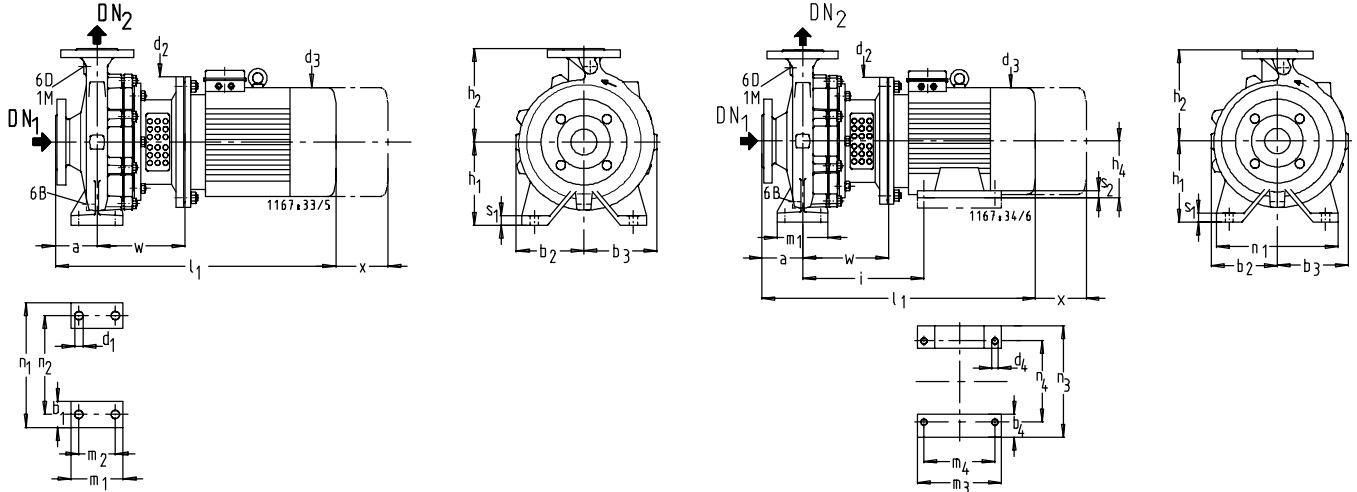

		Etabloc G, M		Etabloc SN, CN	
		Etabloc GN, MN, BN	DN ₂ 32 - DN ₂ 80	DN ₂ 100	DN ₂ 32 - DN ₂ 80
1 M	Присоединение манометра	Rc 3/8 ¹⁾	Rc 1/2 ¹⁾	G 3/8 ¹⁾	G 1/2 ¹⁾
6 B	Перекачиваемая жидкость-Опорожнение	Rc 3/8 ¹⁾	Rc 1/2 ¹⁾	G 3/8 ¹⁾	G 1/2 ¹⁾
6 D	Перекачиваемая жидкость-Заполнение и опорожнение	Rc 3/8 ¹⁾	Rc 1/2 ¹⁾	G 3/8 ¹⁾	G 1/2 ¹⁾

Etabloc BN, SN, CN	M	n = 1450	n = 1750	Допуски присоединительных размеров по EN 735																											
				DN ₁	DN ₂	a	b ₁	b ₂	b ₃	b ₄	d ₁	d ₂	d ₃	d ₄	h ₁	h ₂	h ₄	i	l ₁	m ₁	m ₂	m ₃	m ₄	n ₁	n ₂	n ₃	n ₄	s ₁	s ₂	w	x
40-315/224	100L	x		65 ⁵⁾	40	125	65	194	203		14	250	213		225	250			628	125	95			345	280			18		190	100
40-315/304	100L	x		65 ⁵⁾	40	125	65	194	203		14	250	213		225	250			628	125	95			345	280			18		190	100
40-315/404	112M	x	x	65 ⁵⁾	40	125	65	194	203		14	250	234		225	250			649	125	95			345	280			18		190	100
40-315/554 ³⁾⁴⁾	132S	x	x	65 ⁵⁾	40	125	65	194	203	55	14	300	266	12	225	250	132	302	737	125	95	220	140	345	280	270	216	18	15	213	100
40-315/754 ³⁾⁴⁾	132M		x	65 ⁵⁾	40	125	65	194	203	59	14	300	298	12	225	250	132	302	759	125	95	240	178	345	280	270	216	18	15	213	100
40-315/1104 ³⁾⁴⁾	160M		x	65 ⁵⁾	40	125	65	194	203	70	14	350	325	15	225	250	160	354	917	125	95	300	210	345	280	320	254	18	21	246	100
50-125/054	80	x		65 ⁵⁾	50	100	50	113	128		14	200	162		132	160			511	100	70			240	190			18		156	100
50-125/074	80	x	x	65 ⁵⁾	50	100	50	113	128		14	200	162		132	160			511	100	70			240	190			18		156	100
50-125/114	90S	x	x	65 ⁵⁾	50	100	50	113	128		14	200	190		132	160			538	100	70			240	190			18		156	100
50-125/154	90L		x	65 ⁵⁾	50	100	50	113	128		14	200	190		132	160			545	100	70			240	190			18		156	100
50-160/074	80	x		65 ⁵⁾	50	100	50	126	147		14	200	162		160	180			511	100	70			265	212			18		156	100
50-160/114	90S	x	x	65 ⁵⁾	50	100	50	126	147		14	200	190		160	180			538	100	70			265	212			18		156	100
50-160/154	90L	x	x	65 ⁵⁾	50	100	50	126	147		14	200	190		160	180			545	100	70			265	212			18		156	100
50-160/224	100L		x	65 ⁵⁾	50	100	50	126	147		14	250	213		160	180			583	100	70			265	212			18		170	100
50-160/304	100L		x	65 ⁵⁾	50	100	50	126	147		14	250	213		160	180			583	100	70			265	212			18		170	100
50-200/154	90L	x		65 ⁵⁾	50	100	50	145	165		14	200	190		160	200			545	100	70			265	212			18		156	100
50-200/224	100L	x	x	65 ⁵⁾	50	100	50	145	165		14	250	213		160	200			583	100	70			265	212			18		170	100
50-200/304	100L	x	x	65 ⁵⁾	50	100	50	145	165		14	250	213		160	200			583	100	70			265	212			18		170	100
50-200/404	112M		x	65 ⁵⁾	50	100	50	145	165		14	250	234		160	200			604	100	70			265	212			18		170	100
50-200/554 ³⁾⁴⁾	132S		x	65 ⁵⁾	50	100	50	145	165	55	14	300	266	12	180	200	132	282	692	100	70	220	140	265	212	270	216	18	15	193	100
50-250/224	100L	x	x	65 ⁵⁾	50	100	65	168	184		14	250	213		180	225			583	125	95			320	250			18		170	100
50-250/304	100L	x		65 ⁵⁾	50	100	65	168	184		14	250	213		180	225			583	125	95			320	250			18		170	100
50-250/404	112M	x	x	65 ⁵⁾	50	100	65	168	184		14	250	234		180	225			604	125	95			320	250			18		170	100
50-250/554 ³⁾⁴⁾	132S		x	65 ⁵⁾	50	100	65	168	184	55	14	300	266	12	180	225	132	282	692	125	95	220	140	320	250	270	216	18	15	193	100
50-250/754 ³⁾⁴⁾	132M		x	65 ⁵⁾	50	100	65	168	184	59	14	300	298	12	180	225	132	282	714	125	95	240	178	320	250	270	216	18	15	193	100
50-250/1104 ³⁾⁴⁾	160M		x	65 ⁵⁾	50	100	65	168	184	70	14	350	325	15	180	225	160	334	872	125	95	300	210	320	250	320	254	18	21	226	100

1) Rc = ISO 7/1; G = ISO 228/1

2) Etabloc BN: DN=ISO 7005-3/DN.../PN10/21; Etabloc SN: DN=EN 1092-2/DN.../PN16/21/JS1025/B; Etabloc CN: DN=EN 1092-1/DN.../PN16/21/B / DN200=EN 1092-1/DN200/PN10/21/B

3) при этих типоразмерах опорные лапы электродвигателя должны стоять на фундаменте толщиной 20 мм

4) $h_1 \geq h_4$

5) Фланцы DN₁ 65 / DN₂ 65 4 отверстия

Etabloc BN, SN, CN 50-315/... до 65-250/..., n = 1450 об/мин, n = 1750 об/мин

без опорной лапы электродвигателя
(до типоразмера электродвигателя 112 = 4 кВт)
с опорной лапой электродвигателя
(начиная с типоразмера электродвигателя 132 = 5,5 кВт)

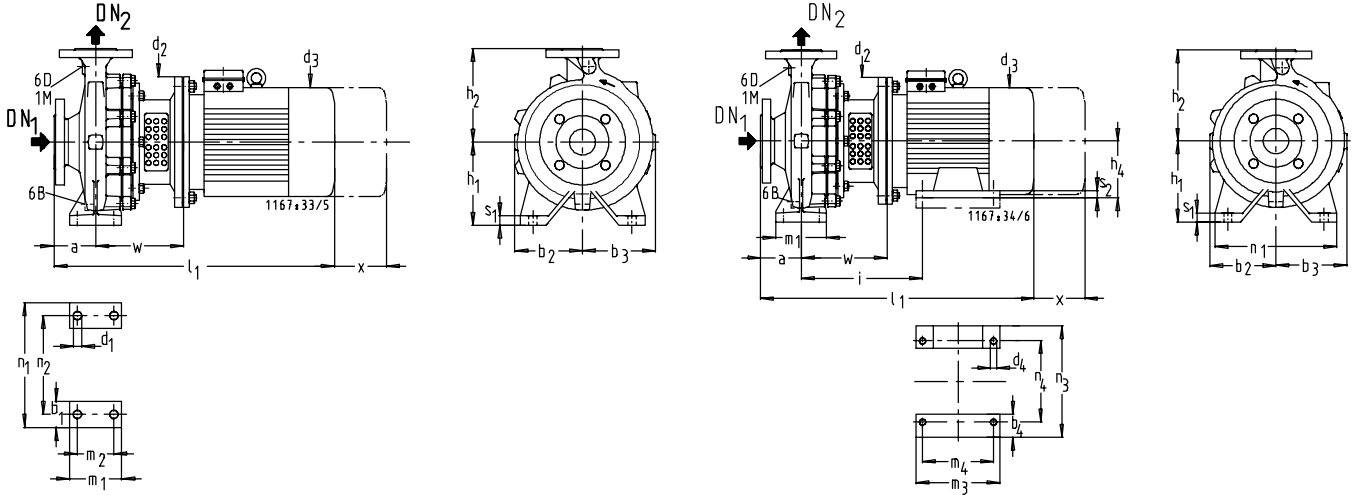

		Etabloc G, M		Etabloc SN, CN	
		Etabloc GN, MN, BN		DN ₂ 32 - DN ₂ 80	DN ₂ 100 - DN ₂ 150
1 M	Присоединение манометра	Rc 3/8 ¹⁾	Rc 1/2 ¹⁾	G 3/8 ¹⁾	G 1/2 ¹⁾
6 B	Перекачиваемая жидкость-Опорожнение	Rc 3/8 ¹⁾	Rc 1/2 ¹⁾	G 3/8 ¹⁾	G 1/2 ¹⁾
6 D	Перекачиваемая жидкость-Заполнение и опорожнение	Rc 3/8 ¹⁾	Rc 1/2 ¹⁾	G 3/8 ¹⁾	G 1/2 ¹⁾

Etabloc BN, SN, CN	M	n = 1450	n = 1750	Допуски присоединительных размеров по EN 735																											
				DN ₁	DN ₂	a	b ₁	b ₂	b ₃	b ₄	d ₁	d ₂	d ₃	d ₄	h ₁	h ₂	h ₄	i	l ₁	m ₁	m ₂	m ₃	m ₄	n ₁	n ₂	n ₃	n ₄	s ₁	s ₂	w	x
50-315/304	100L	x		65 ⁵⁾	50	125	65	200	216		14	250	213		225	280			628	125	95			345	280			18		190	100
50-315/404	112M	x		65 ⁵⁾	50	125	65	200	216		14	250	234		225	280			649	125	95			345	280			18		190	100
50-315/554 ³⁾⁴⁾	132S	x	x	65 ⁵⁾	50	125	65	200	216	55	14	300	266	12	225	280	132	302	737	125	95	220	140	345	280	270	216	18	15	213	100
50-315/754 ³⁾⁴⁾	132M	x	x	65 ⁵⁾	50	125	65	200	216	59	14	300	298	12	225	280	132	302	759	125	95	240	178	345	280	270	216	18	15	213	100
50-315/1104 ³⁾⁴⁾	160M		x	65 ⁵⁾	50	125	65	200	216	70	14	350	325	15	225	280	160	354	917	125	95	300	210	345	280	320	254	18	21	246	100
50-315/1504 ³⁾⁴⁾	160L		x	65 ⁵⁾	50	125	65	200	216	70	14	350	325	15	225	280	160	354	917	125	95	314	254	345	280	320	254	18	21	246	100
65-125/054	80	x		80	65 ⁵⁾	100	65	120	148		14	200	162		160	180			511	125	95			280	212			18		156	100
65-125/074	80	x	x	80	65 ⁵⁾	100	65	120	148		14	200	162		160	180			511	125	95			280	212			18		156	100
65-125/114	90S	x	x	80	65 ⁵⁾	100	65	120	148		14	200	190		160	180			538	125	95			280	212			18		156	100
65-125/154	90L		x	80	65 ⁵⁾	100	65	120	148		14	200	190		160	180			545	125	95			280	212			18		156	100
65-125/224	100L		x	80	65 ⁵⁾	100	65	120	148		14	250	213		160	180			583	125	95			280	212			18		170	100
65-160/114	90S	x		80	65 ⁵⁾	100	65	130	158		14	200	190		160	200			538	125	95			280	212			18		156	100
65-160/154	90L	x	x	80	65 ⁵⁾	100	65	130	158		14	200	190		160	200			545	125	95			280	212			18		156	100
65-160/224	100L	x	x	80	65 ⁵⁾	100	65	130	158		14	250	213		160	200			583	125	95			280	212			18		170	100
65-160/304	100L		x	80	65 ⁵⁾	100	65	130	158		14	250	213		160	200			583	125	95			280	212			18		170	100
65-160/404	112M		x	80	65 ⁵⁾	100	65	130	158		14	250	234		160	200			604	125	95			280	212			18		170	100
65-200/224	100L	x		80	65 ⁵⁾	100	65	154	177		14	250	213		180	225			583	125	95			320	250			18		170	140
65-200/304	100L	x		80	65 ⁵⁾	100	65	154	177		14	250	213		180	225			583	125	95			320	250			18		170	140
65-200/404	112M	x	x	80	65 ⁵⁾	100	65	154	177		14	250	234		180	225			604	125	95			320	250			18		170	140
65-200/554 ³⁾⁴⁾	132S		x	80	65 ⁵⁾	100	65	154	177	55	14	300	266	12	180	225	132	282	692	125	95	220	140	320	250	270	216	18	15	193	140
65-200/754 ³⁾⁴⁾	132M		x	80	65 ⁵⁾	100	65	154	177	59	14	300	298	12	180	225	132	282	714	125	95	240	178	320	250	270	216	18	15	193	140
65-250/304	100L	x		80	65 ⁵⁾	100	80	180	200		18	250	213		200	250			603	160	120			360	280			20		190	140
65-250/404	112M	x		80	65 ⁵⁾	100	80	180	200		18	250	234		200	250			624	160	120			360	280			20		190	140
65-250/554 ³⁾⁴⁾	132S	x	x	80	65 ⁵⁾	100	80	180	200	55	18	300	266	12	200	250	132	302	712	160	120	220	140	360	280	270	216	20	15	213	140
65-250/754 ³⁾⁴⁾	132M		x	80	65 ⁵⁾	100	80	180	200	59	18	300	298	12	200	250	132	302	734	160	120	240	178	360	280	270	216	20	15	213	140
65-250/1104 ³⁾⁴⁾	160M		x	80	65 ⁵⁾	100	80	180	200	70	18	350	325	15	200	250	160	354	892	160	120	300	210	360	280	320	254	20	21	246	140

1) Rc = ISO 7/1; G = ISO 228/1
 2) Etabloc BN: DN=ISO 7005-3/DN.../PN10/21; Etabloc SN: DN=EN 1092-2/DN.../PN16/21/JS1025/B; Etabloc CN: DN=EN 1092-1/DN.../PN16/21/B / DN200=EN 1092-1/DN200/PN10/21/B
 3) при этих типоразмерах опорные лапы электродвигателя должны стоять на фундаменте толщиной 20 мм
 4) $h_1 \geq h_4$
 5) Фланцы DN₁ 65 / DN₂ 65 4 отверстия

Etabloc BN, SN, CN 65-315/... до 80-125/..., n = 1450 об/мин, n = 1750 об/мин

без опорной лапы электродвигателя
(до типоразмера электродвигателя 112 = 4 кВт)
с опорной лапой электродвигателя
(начиная с типоразмера электродвигателя 132 = 5,5 кВт)

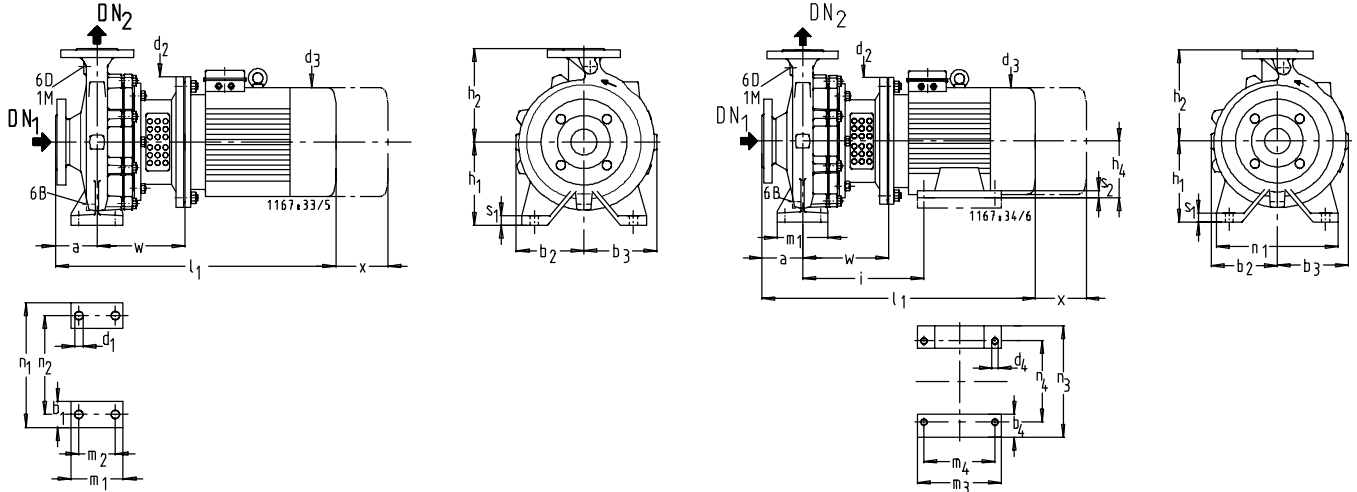

		Etabloc G, M		Etabloc SN, CN	
		Etabloc GN, MN, BN	DN ₂ 32 - DN ₂ 80	DN ₂ 100	DN ₂ 32 - DN ₂ 80
1 M	Присоединение манометра	Rc 3/8 ¹⁾	Rc 1/2 ¹⁾	G 3/8 ¹⁾	G 1/2 ¹⁾
6 B	Перекачиваемая жидкость-Опорожнение	Rc 3/8 ¹⁾	Rc 1/2 ¹⁾	G 3/8 ¹⁾	G 1/2 ¹⁾
6 D	Перекачиваемая жидкость-Заполнение и опорожнение	Rc 3/8 ¹⁾	Rc 1/2 ¹⁾	G 3/8 ¹⁾	G 1/2 ¹⁾

Etabloc BN, SN, CN	M	n = 1450	n = 1750	Допуски присоединительных размеров по EN 735																												
				DN ₁	DN ₂	a	b ₁	b ₂	b ₃	b ₄	d ₁	d ₂	d ₃	d ₄	h ₁	h ₂	h ₄	i	l ₁	m ₁	m ₂	m ₃	m ₄	n ₁	n ₂	n ₃	n ₄	s ₁	s ₂	w	x	
65-315/554 ³⁾⁴⁾	132S	x		80	65 ⁵⁾	125	80	208	229	55	18	300	266	12	225	280	132	302	737	160	120	220	140	400	315	270	216	20	15	213	140	
65-315/754 ³⁾⁴⁾	132M	x		80	65 ⁵⁾	125	80	208	229	59	18	300	298	12	225	280	132	302	759	160	120	240	178	400	315	270	216	20	15	213	140	
65-315/1104 ³⁾⁴⁾	160M	x	x	80	65 ⁵⁾	125	80	208	229	70	18	350	325	15	225	280	160	354	917	160	120	300	210	400	315	320	254	20	21	246	140	
65-315/1504 ³⁾⁴⁾	160L	x	x	80	65 ⁵⁾	125	80	208	229	70	18	350	325	15	225	280	160	354	917	160	120	314	254	400	315	320	254	20	21	246	140	
65-315/1854 ⁴⁾	180M		x	80	65 ⁵⁾	125	80	208	229	80	18	350	370	15	225	280	180	367	981	160	120	320	241	400	315	360	279	20	23	246	140	
65-315/2204 ⁴⁾	180L		x	80	65 ⁵⁾	125	80	208	229	80	18	350	370	15	225	280	180	367	981	160	120	358	279	400	315	360	279	20	23	246	140	
80-160/154	90L	x		100	80	125	65	153	192		14	200	190		180	225			570	125	95			320	250			18		156	140	
80-160/224	100L	x		100	80	125	65	153	192		14	250	213		180	225			608	125	95			320	250			18		170	140	
80-160/304	100L	x		100	80	125	65	153	192		14	250	213		180	225			608	125	95			320	250			18		170	140	
80-160/404	112M	x	x	100	80	125	65	153	192		14	250	234		180	225			629	125	95			320	250			18		170	140	
80-160/554 ³⁾⁴⁾	132S		x	100	80	125	65	153	192	55	14	300	266	12	180	225	132	282	717	125	95	220	140	320	250	270	216	18	15	193	140	
80-200/224	100L	x		100	80	125	65	161	189		14	250	213		180	250			628	125	95			345	280			18		190	140	
80-200/304	100L	x		100	80	125	65	161	189		14	250	213		180	250			628	125	95			345	280			18		190	140	
80-200/404	112M	x		100	80	125	65	161	189		14	250	234		180	250			649	125	95			345	280			18		190	140	
80-200/554 ³⁾⁴⁾	132S	x	x	100	80	125	65	161	189	55	14	300	266	12	180	250	132	302	737	125	95	220	140	345	280	270	216	18	15	213	140	
80-200/754 ³⁾⁴⁾	132M		x	100	80	125	65	161	189	59	14	300	298	12	180	250	132	302	759	125	95	240	178	400	315	280	270	216	18	15	213	140
80-200/1104 ³⁾⁴⁾	160M		x	100	80	125	65	161	189	70	14	350	325	15	180	250	160	354	917	125	95	300	210	345	280	320	254	18	21	246	140	
80-250/404	112M	x		100	80	125	80	184	210		18	250	234		200	280			649	160	120			400	315			18		190	140	
80-250/554 ³⁾⁴⁾	132S	x		100	80	125	80	184	210	55	18	300	266	12	200	280	132	302	737	160	120	220	140	400	315	270	216	18	15	213	140	
80-250/754 ³⁾⁴⁾	132M	x	x	100	80	125	80	184	210	59	18	300	298	12	200	280	132	302	759	160	120	240	178	400	315	270	216	18	15	213	140	
80-250/1104 ³⁾⁴⁾	160M	x	x	100	80	125	80	184	210	70	18	350	325	15	200	280	160	354	917	160	120	300	210	400	315	320	254	18	21	246	140	
80-250/1504 ³⁾⁴⁾	160L		x	100	80	125	80	184	210	70	18	350	325	15	200	280	160	354	917	160	120	314	254	400	315	320	254	18	21	246	140	
80-250/1854 ⁴⁾	180M		x	100	80	125	80	184	210	80	18	350	370	15	200	280	180	367	981	160	120	320	241	400	315	360	279	18	23	246	140	
80-315/754 ³⁾⁴⁾	132M	x		100	80	125	80	220	244	59	18	300	298	12	250	315	132	302	759	160	120	240	178	400	315	270	216	20	15	213	140	
80-315/1104 ³⁾⁴⁾	160M	x		100	80	125	80	220	244	70	18	350	325	15	250	315	160	354	917	160	120	300	210	400	315	320	254	20	21	246	140	
80-315/1504 ³⁾⁴⁾	160L	x	x	100	80	125	80	220	244	70	18	350	325	15	250	315	160	354	917	160	120	314	254	400	315	320	254	20	21	246	140	
80-315/1854 ⁴⁾	180M	x	x	100	80	125	80	220	244	80	18	350	370	15	250	315	180	367	981	160	120	320	241	400	315	360	279	20	23	246	140	
80-315/2204 ⁴⁾	180L	x	x	100	80	125	80	220	244	80	18	350	370	15	250	315	180	367	981	160	120	358	279	400	315	360	279	20	23	246	140	

1) Rc = ISO 7/1; G = ISO 228/1
 2) Etabloc BN: DN=ISO 7005-3/DN.../PN10/21; Etabloc SN: DN=EN 1092-2/DN.../PN16/21/JS1025/B; Etabloc CN: DN=EN 1092-1/DN.../PN16/21/B / DN200=EN 1092-1/DN200/PN10/21/B
 3) при этих типоразмерах опорные лапы электродвигателя должны стоять на фундаменте толщиной 20 мм
 4) $h_1 \geq h_4$
 5) Фланцы DN₁ 65 / DN₂ 65 4 отверстия

Etabloc BN, SN, CN 100-160/... до 150-250/..., n = 1450 об/мин, n = 1750 об/мин

без опорной лапы электродвигателя

(до типоразмера электродвигателя 112 = 4 кВт)

с опорной лапой электродвигателя

(начиная с типоразмера электродвигателя 132 = 5,5 кВт)

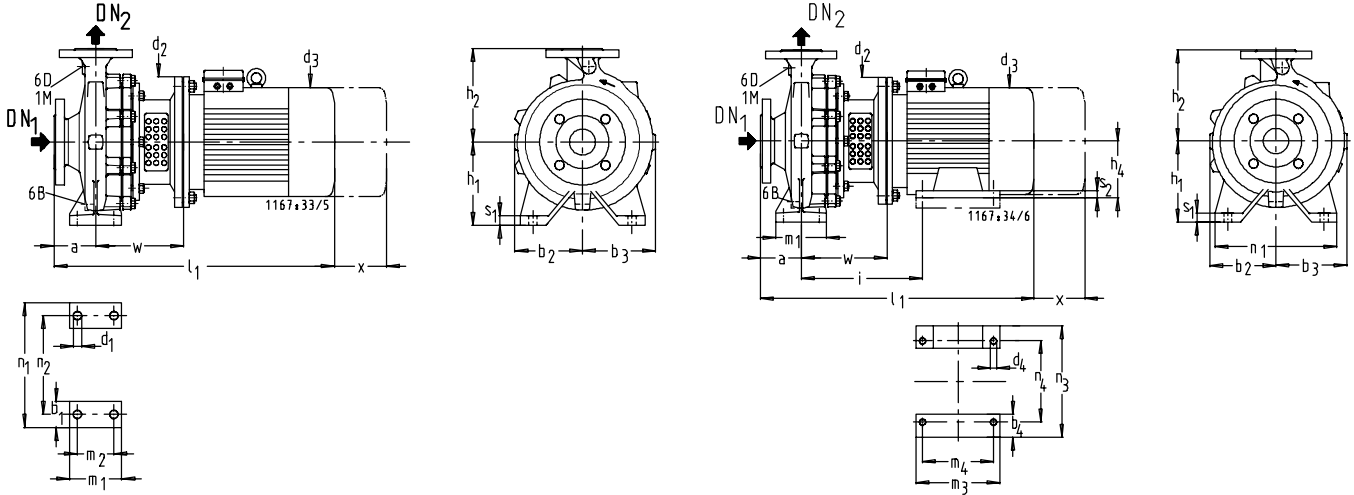

		Etabloc G, M		Etabloc SN, CN	
		Etabloc GN, MN, BN			
		DN ₂ 32 - DN ₂ 80	DN ₂ 100	DN ₂ 32 - DN ₂ 80	DN ₂ 100 - DN ₂ 150
1 M	Присоединение манометра	Rc 3/8 ¹⁾	Rc 1/2 ¹⁾	G 3/8 ¹⁾	G 1/2 ¹⁾
6 B	Перекачиваемая жидкость-Опорожнение	Rc 3/8 ¹⁾	Rc 1/2 ¹⁾	G 3/8 ¹⁾	G 1/2 ¹⁾
6 D	Перекачиваемая жидкость-Заполнение и опорожнение	Rc 3/8 ¹⁾	Rc 1/2 ¹⁾	G 3/8 ¹⁾	G 1/2 ¹⁾

Etabloc BN, SN, CN	Ⓜ	n = 1450	n = 1750	Допуски присоединительных размеров по EN 735																											
				DN ₁ 2)	DN ₂ 2)	a	b ₁ ≈	b ₂ ≈	b ₃ ≈	b ₄ ≈	d ₁	d ₂	d ₃ ≈	d ₄	h ₁	h ₂	h ₄	i	l ₁ ≈	m ₁ ≈	m ₂	m ₃ ≈	m ₄	n ₁	n ₂	n ₃ ≈	n ₄	s ₁	s ₂	w	x
100-160/304	100L	x		125	100	125	80	178	225		18	250	213		200	280			628	160	120			360	280			18		190	140
100-160/404	112M	x		125	100	125	80	178	225		18	250	234		200	280			649	160	120			360	280			18		190	140
100-160/554 ³⁾⁴⁾	132S	x	x	125	100	125	80	178	225	55	18	300	266	12	200	280	132	302	737	160	120	220	140	360	280	270	216	18	15	213	140
100-160/754 ³⁾⁴⁾	132M		x	125	100	125	80	178	225	59	18	300	298	12	200	280	132	302	759	160	120	240	178	360	280	270	216	18	15	213	140
100-200/404	112M	x		125	100	125	80	173	213		18	250	234		200	280			649	160	120			360	280			18		190	140
100-200/554 ³⁾⁴⁾	132S	x		125	100	125	80	173	213	55	18	300	266	12	200	280	132	302	737	160	120	220	140	360	280	270	216	18	15	213	140
100-200/754 ³⁾⁴⁾	132M	x	x	125	100	125	80	173	213	59	18	300	298	12	200	280	132	302	759	160	120	240	178	360	280	270	216	18	15	213	140
100-200/1104 ³⁾⁴⁾	160M		x	125	100	125	80	173	213	70	18	350	325	15	200	280	160	354	917	160	120	300	210	360	280	320	254	18	21	246	140
100-200/1504 ³⁾⁴⁾	160L		x	125	100	125	80	173	213	70	18	350	325	15	200	280	160	354	917	160	120	314	254	360	280	320	254	18	21	246	140
100-250/754 ³⁾⁴⁾	132M	x		125	100	140	80	190	220	59	18	300	298	12	225	280	132	302	774	160	120	240	178	400	315	270	216	18	15	213	140
100-250/1104 ³⁾⁴⁾	160M	x	x	125	100	140	80	190	220	70	18	350	325	15	225	280	160	354	932	160	120	300	210	400	315	320	254	18	21	246	140
100-250/1504 ³⁾⁴⁾	160L	x	x	125	100	140	80	190	220	70	18	350	325	15	225	280	160	354	932	160	120	314	254	400	315	320	254	18	21	246	140
100-250/1854 ⁴⁾	180M		x	125	100	140	80	190	220	80	18	350	370	15	225	280	180	367	996	160	120	320	241	400	315	360	279	18	23	246	140
100-250/2204 ⁴⁾	180L		x	125	100	140	80	190	220	80	18	350	370	15	225	280	180	367	996	160	120	358	279	400	315	360	279	18	23	246	140
100-315/1504 ³⁾⁴⁾	160L	x		125	100	140	80	225	255	70	18	350	325	15	250	315	160	354	932	160	120	314	254	400	315	320	254	18	21	246	140
100-315/1854 ⁴⁾	180M	x	x	125	100	140	80	225	255	80	18	350	370	15	250	315	180	367	996	160	120	320	241	400	315	360	279	18	23	246	140
100-315/2204 ⁴⁾	180L	x	x	125	100	140	80	225	255	80	18	350	370	15	250	315	180	367	996	160	120	358	279	400	315	360	279	18	23	246	140
125-200/754 ³⁾⁴⁾	132M	x		150	125	140	80	195	244	59	18	300	298	12	250	315	132	302	774	160	120	240	178	400	315	270	216	20	15	213	140
125-200/1104 ³⁾⁴⁾	160M	x	x	150	125	140	80	195	244	70	18	350	325	15	250	315	160	354	932	160	120	300	210	400	315	320	254	20	21	246	140
125-200/1504 ³⁾⁴⁾	160L	x	x	150	125	140	80	195	244	70	18	350	325	15	250	315	160	354	932	160	120	314	254	400	315	320	254	20	21	246	140
125-200/1854 ⁴⁾	180M		x	150	125	140	80	195	244	80	18	350	370	15	250	315	180	367	996	160	120	320	241	400	315	360	279	20	23	246	140
125-200/2204 ⁴⁾	180L		x	150	125	140	80	195	244	80	18	350	370	15	250	315	180	367	996	160	120	358	279	400	315	360	279	20	23	246	140
125-250/1104 ³⁾⁴⁾	160M	x		150	125	140	80	226	275	70	18	350	325	15	250	315	160	354	932	160	120	300	210	400	315	320	254	20	21	246	140
125-250/1504 ³⁾⁴⁾	160L	x	x	150	125	140	80	226	275	70	18	350	325	15	250	315	160	354	932	160	120	314	254	400	315	320	254	20	21	246	140
125-250/1854 ⁴⁾	180M	x	x	150	125	140	80	226	275	80	18	350	370	15	250	315	180	367	996	160	120	320	241	400	315	360	279	20	23	246	140
125-250/2204 ⁴⁾	180L	x	x	150	125	140	80	226	275	80	18	350	370	15	250	315	180	367	996	160	120	358	279	400	315	360	279	20	23	246	140
150-200/754 ³⁾⁴⁾	132M	x		200	150	160	100	238	315	59	23	300	298	12	280	400	132	302	794	200	150	240	178	550	450	270	216	20	15	213	140
150-200/1104 ³⁾⁴⁾	160M	x		200	150	160	100	238	315	70	23	350	325	15	280	400	160	354	952	200	150	300	210	550	450	320	254	20	21	246	140
150-200/1504 ³⁾⁴⁾	160L	x	x	200	150	160	100	238	315	70	23	350	325	15	280	400	160	354	952	200	150	314	254	550	450	320	254	20	21	246	140
150-200/1854 ⁴⁾	180M		x	200	150	160	100	238	315	80	23	350	370	15	280	400	180	367	1016	200	150	320	241	550	450	360	279	20	23	246	140
150-200/2204 ⁴⁾	180L		x	200	150	160	100	238	315	80	23	350	370	15	280	400	180	367	1016	200	150	358	279	550	450	360	279	20	23	246	140
150-250/1504 ³⁾⁴⁾	160L	x		200	150	160	100	228	298	70	23	350	325	15	280	400	160	354	952	200	150	314	254	500	400	320	254	20	21	246	140
150-250/1854 ⁴⁾	180M	x		200	150	160	100	228	298	80	23	350	370	15	280	400	180	367	1016	200	150	320	241	500	400	360	279	20	23	246	140
150-250/2204 ⁴⁾	180L	x	x	200	150	160	100	228	298	80	23	350	370	15	280	400	180	367	1016	200	150	358	279	500	400	360	279	20	23	246	140

1) Rc = ISO 7/1; G = ISO 228/1

2) Etabloc BN: DN=ISO 7005-3/DN.../PN10/21; Etabloc SN: DN=EN 1092-2/DN.../PN16/21/JS1025/B; Etabloc CN: DN=EN 1092-1/DN.../PN16/21/B / DN200=EN 1092-1/DN200/PN10/21/B

3) при этих типоразмерах опорные лапы электродвигателя должны стоять на фундаменте толщиной 20 мм

4) $h_1 \geq h_4$

5) Фланцы DN₁ 65 / DN₂ 65 4 отверстия

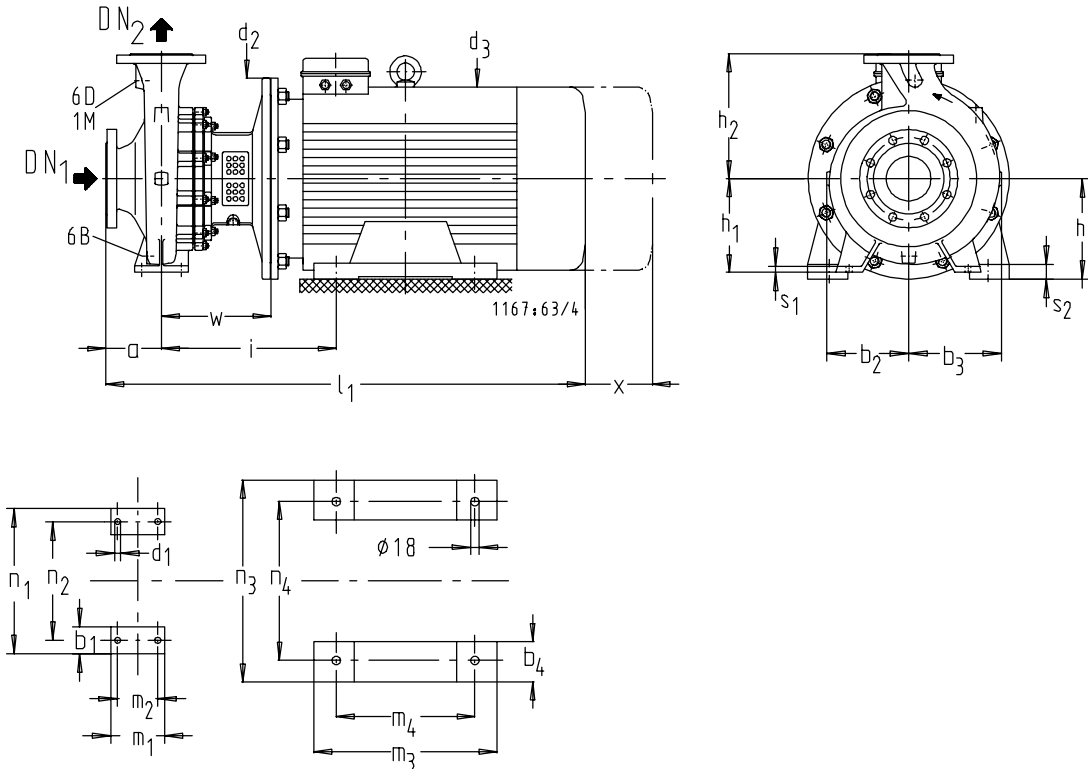
Etabloc GN, MN ≥ 30 кВт, n = 2900 об/мин, n = 3500 об/мин

		Etabloc G, M			
		Etabloc GN, MN, BN		Etabloc SN, CN	
		DN ₂ 32 - DN ₂ 80	DN ₂ 100	DN ₂ 32 - DN ₂ 80	DN ₂ 100 - DN ₂ 150
1 M	Присоединение манометра	Rc 3/8 ¹⁾	Rc 1/2 ¹⁾	G 3/8 ¹⁾	G 1/2 ¹⁾
6 B	Перекачиваемая жидкость-Опорожнение	Rc 3/8 ¹⁾	Rc 1/2 ¹⁾	G 3/8 ¹⁾	G 1/2 ¹⁾
6 D	Перекачиваемая жидкость-Заполнение и опорожнение	Rc 3/8 ¹⁾	Rc 1/2 ¹⁾	G 3/8 ¹⁾	G 1/2 ¹⁾

MM

Etabloc GN, MN	M	n = 2900	n = 3500	Допуски присоединительных размеров по EN 735																											
				DN ₁	DN ₂	a	b ₁	b ₂	b ₃	b ₄	d ₁	d ₂	d ₃	d ₄	h ₁	h ₂	h ₄	i	l ₁	m ₁	m ₂	m ₃	m ₄	n ₁	n ₂	n ₃	n ₄	s ₁	s ₂	w	x
50-200/3002	200L		x	65	50	100	50	145	165	85	14	400	422	19	160	200	200	359	995	100	70	388	305	265	212	400	318	18	30	226	100
50-200/3702	200L		x	65	50	100	50	145	165	85	14	400	422	19	160	200	200	359	995	100	70	388	305	265	212	400	318	18	30	226	100
50-250/3002	200L	x		65	50	100	65	168	184	85	14	400	422	19	180	225	200	359	995	125	95	388	305	320	250	400	318	18	30	226	100
50-250/3702	200L	x		65	50	100	65	168	184	85	14	400	422	19	180	225	200	359	995	125	95	388	305	320	250	400	318	18	30	226	100
65-160/3002	200L		x	80	65	100	65	130	158	85	14	400	422	19	160	200	200	359	995	125	95	388	305	280	212	400	318	18	30	226	100
65-200/3002	200L		x	80	65	100	65	154	177	85	14	400	422	19	180	225	200	359	995	125	95	388	305	320	250	400	318	18	30	226	140
65-200/3702	200L		x	80	65	100	65	154	177	85	14	400	422	19	180	225	200	359	995	125	95	388	305	320	250	400	318	18	30	226	140
65-250/3002 ³⁾	200L	x		80	65	100	80	180	200	85	18	400	422	19	200	250	200	379	1015	160	120	388	305	360	280	400	318	20	30	246	140
65-250/3702 ³⁾	200L	x		80	65	100	80	180	200	85	18	400	422	19	200	250	200	379	1015	160	120	388	305	360	280	400	318	20	30	246	140
65-250/4502	225M	x		80	65	100	80	180	200	100	18	450	468	19	200	250	225	419	1092	160	120	410	311	360	280	450	356	20	35	270	140
80-160/3002	200L	x	x	100	80	125	65	153	192	85	14	400	422	19	180	225	200	359	1020	125	95	388	305	320	250	400	318	18	30	226	140
80-160/3702	200L		x	100	80	125	65	153	192	85	14	400	422	19	180	225	200	359	1020	125	95	388	305	320	250	400	318	18	30	226	140
80-200/3002	200L	x		100	80	125	65	161	189	85	14	400	422	19	180	250	200	379	1040	125	95	388	305	345	280	400	318	18	30	246	140
80-200/3702	200L	x		100	80	125	65	161	189	85	14	400	422	19	180	250	200	379	1040	125	95	388	305	345	280	400	318	18	30	246	140
80-200/4502	225M	x	x	100	80	125	65	161	189	100	14	450	468	19	180	250	225	419	1117	125	95	410	311	345	280	450	356	18	35	270	140
80-250/3002 ³⁾	200L	x		100	80	125	80	184	210	85	18	400	422	19	200	280	200	379	1040	160	120	388	305	400	315	400	318	18	30	246	140
80-250/3702 ³⁾	200L	x		100	80	125	80	184	210	85	18	400	422	19	200	280	200	379	1040	160	120	388	305	400	315	400	318	18	30	246	140
80-250/4502	225M	x		100	80	125	80	184	210	100	18	450	468	19	200	280	225	419	1117	160	120	410	311	400	315	450	356	18	35	270	140
100-160/3002 ³⁾	200L	x		125	100	125	80	178	225	85	18	400	422	19	200	280	200	379	1040	160	120	388	305	360	280	400	318	18	30	246	140
100-160/3702 ³⁾	200L	x	x	125	100	125	80	178	225	85	18	400	422	19	200	280	200	379	1040	160	120	388	305	360	280	400	318	18	30	246	140
100-160/4502	225M		x	125	100	125	80	178	225	100	18	450	468	19	200	280	225	419	1117	160	120	410	311	360	280	450	356	18	35	270	140
100-200/3002 ³⁾	200L	x		125	100	125	80	173	213	85	18	400	422	19	200	280	200	379	1040	160	120	388	305	360	280	400	318	18	30	246	140
100-200/3702 ³⁾	200L	x		125	100	125	80	173	213	85	18	400	422	19	200	280	200	379	1040	160	120	388	305	360	280	400	318	18	30	246	140
100-200/4502	225M	x		125	100	125	80	173	213	100	18	450	468	19	200	280	225	419	1117	160	120	410	311	360	280	450	356	18	35	270	140

1) Rc = ISO 7/1; G = ISO 228/1

2) DN = EN 1092-2/DN.../PN16/21/JL1040/B

 3) h₁ ≥ h₄

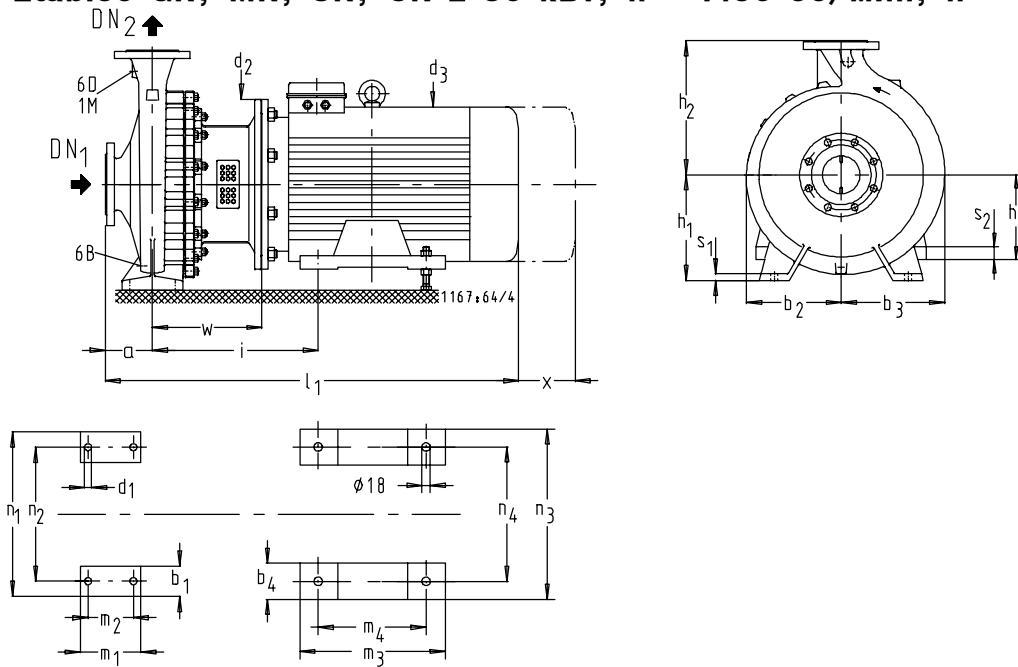
Etabloc GN, MN, SN, CN ≥ 30 кВт, n = 1450 об/мин, n = 1750 об/мин

		Etabloc G, M		Etabloc SN, CN	
		Etabloc GN, MN, BN		DN ₂ 32 - DN ₂ 80	DN ₂ 100 - DN ₂ 150
1 M	Присоединение манометра	Rc 3/8 ¹⁾	Rc 1/2 ¹⁾	G 3/8 ¹⁾	G 1/2 ¹⁾
6 B	Перекачиваемая жидкость-Опорожнение	Rc 3/8 ¹⁾	Rc 1/2 ¹⁾	G 3/8 ¹⁾	G 1/2 ¹⁾
6 D	Перекачиваемая жидкость-Заполнение и опорожнение	Rc 3/8 ¹⁾	Rc 1/2 ¹⁾	G 3/8 ¹⁾	G 1/2 ¹⁾

Etabloc GN, MN, SN, CN	M	n = 1450	n = 1750	Допуски присоединительных размеров по EN 735																											
				DN ₁	DN ₂	a	b ₁ ≈	b ₂ ≈	b ₃ ≈	b ₄ ≈	d ₁	d ₂	d ₃	d ₄	h ₁	h ₂	h ₄	i	l ₁ ≈	m ₁ ≈	m ₂	m ₃ ≈	m ₄	n ₁	n ₂	n ₃ ≈	n ₄	s ₁	s ₂	w	x
80-315/3004 ³⁾	200L	x	x	100	80	125	80	220	244	85	18	400	422	19	250	315	200	379	1040	160	120	388	305	400	315	400	318	20	30	246	140
80-315/3704 ³⁾	225S	x	x	100	80	125	80	220	244	100	18	450	460	19	250	315	225	419	1085	160	120	385	286	400	315	450	356	20	35	270	140
80-400/3004 ³⁾	200L	x	x	100	80	125	80	253	276	85	18	400	422	19	280	355	200	391	1052	160	120	388	305	435	355	400	318	20	30	258	140
80-400/3704 ³⁾	225S	x	x	100	80	125	80	253	276	100	18	450	460	19	280	355	225	437	1103	160	120	385	286	435	355	450	356	20	35	288	140
80-400/4504 ³⁾	225M	x	x	100	80	125	80	253	276	100	18	450	468	19	280	355	225	437	1135	160	120	410	311	435	355	450	356	20	35	288	140
100-315/3004 ³⁾	200L	x	x	125	100	140	80	225	255	85	18	400	422	19	250	315	200	379	1055	160	120	388	305	400	315	400	318	18	30	246	140
100-315/3704 ³⁾	225S	x	x	125	100	140	80	225	255	100	18	450	460	19	250	315	225	419	1100	160	120	385	286	400	315	450	356	18	35	270	140
100-315/4504 ³⁾	225M	x	x	125	100	140	80	225	255	100	18	450	468	19	250	315	225	419	1132	160	120	410	311	400	315	450	356	18	35	270	140
100-400/3004 ³⁾	200L	x	x	125	100	140	100	253	280	85	23	400	422	19	280	355	200	391	1067	200	150	388	305	500	400	400	318	20	30	258	140
100-400/3704 ³⁾	225S	x	x	125	100	140	100	253	280	100	23	450	460	19	280	355	225	437	1118	200	150	385	286	500	400	450	356	20	35	288	140
100-400/4504 ³⁾	225M	x	x	125	100	140	100	253	280	100	23	450	468	19	280	355	225	437	1150	200	150	410	311	500	400	450	356	20	35	288	140
125-250/3004 ³⁾	200L	x	x	150	125	140	80	226	275	85	18	400	422	19	250	315	200	379	1055	160	120	388	305	400	315	400	318	20	30	246	140
125-250/3704 ³⁾	225S	x	x	150	125	140	80	226	275	100	18	450	460	19	250	315	225	419	1100	160	120	385	286	400	315	450	356	20	35	270	140
125-315/3004 ³⁾	200L	x	x	150	125	140	100	238	278	85	23	400	422	19	280	355	200	391	1067	200	150	388	305	500	400	400	318	20	30	258	140
125-315/3704 ³⁾	225S	x	x	150	125	140	100	238	278	100	23	450	460	19	280	355	225	437	1118	200	150	385	286	500	400	450	356	20	35	288	140
125-315/4504 ³⁾	225M	x	x	150	125	140	100	238	278	100	23	450	468	19	280	355	225	437	1150	200	150	410	311	500	400	450	356	20	35	288	140
125-400/3004 ³⁾	200L	x	x	150	125	140	100	275	306	85	23	400	422	19	315	400	200	391	1067	200	150	388	305	500	400	400	318	20	30	258	140
125-400/3704 ³⁾	225S	x	x	150	125	140	100	275	306	100	23	450	460	19	315	400	225	437	1118	200	150	385	286	500	400	450	356	20	35	288	140
125-400/4504 ³⁾	225M	x	x	150	125	140	100	275	306	100	23	450	468	19	315	400	225	437	1150	200	150	410	311	500	400	450	356	20	35	288	140
150-250/3004 ³⁾	200L	x	x	200	150	160	100	228	298	85	23	400	422	19	280	400	200	379	1075	200	150	388	305	500	400	400	318	20	30	246	140
150-250/3704 ³⁾	225S	x	x	200	150	160	100	228	298	100	23	450	460	19	280	400	225	419	1120	200	150	385	286	500	400	450	356	20	35	270	140
150-250/4504 ³⁾	225M	x	x	200	150	160	100	228	298	100	23	450	468	19	280	400	225	419	1152	200	150	410	311	500	400	450	356	20	35	270	140
150-315/3004 ³⁾	200L	x	x	200	150	160	100	255	303	85	23	400	422	19	280	400	200	391	1087	200	150	388	305	550	450	400	318	20	30	258	140
150-315/3704 ³⁾	225S	x	x	200	150	160	100	255	303	100	23	450	460	19	280	400	225	437	1138	200	150	385	286	550	450	450	356	20	35	288	140
150-315/4504 ³⁾	225M	x	x	200	150	160	100	255	303	100	23	450	468	19	280	400	225	437	1170	200	150	410	311	550	450	450	356	20	35	288	140

1) Rc = ISO 7/1; G = ISO 228/1

	DN 80, 100 DN 125, 150	DN 200
Etabloc GN, MN	EN 1092-2/DN.../PN 16/21/JL1040/B	EN 1092-2/DN.../PN 10/21/JL1040/B
Etabloc SN	EN 1092-2/DN.../PN 16/21/JS1025/B	
Etabloc CN	N 1092-1/DN.../PN 16/21/B	EN 1092-1/DN.../PN 10/21/B

 3) h₁ ≥ h₄

Запасные части
Взаимозаменяемость узлов насосов между Etabloc и Etanorm, а также деталей между собой

Etabloc	Узел вала	Наименование-деталей																		
		Спиральный корпус		Крышка корпуса насоса		Вал 1)										Рабочее колесо	Торцовое уплотнение	Щелевое кольцо с всасывающей стороны	Щелевое кольцо с напорной стороны	Втулка вала
		102	163	71	80	90	100 112	132	160	180	200	225	225	230	433	502.1	502.2	523		
25-20/...	25	○	○											○	○	x	x	x		
32-23/...	25	○	x											○	○	x	x	x		
32-125.1/...	25	○	1	1	2	3	4	5	□	□	□	▲	▲	○	1	1	x	1		
32-160.1/...	25	○	1	1	2	3	4	5	□	□	□	▲	▲	1	1	1	3	1		
32-200.1/...	25	○	2	□	2	3	4	5	6	□	□	▲	▲	2	1	1	3	1		
32-250.1/...	25	○	3	□	2	3	4	5	6	□	□	▲	▲	3	1	1	4	1		
32-125/...	25	○	1	1	2	3	4	5	□	□	□	▲	▲	○	1	1	x	1		
32-160/...	25	○	1	□	2	3	4	5	□	□	□	▲	▲	1	1	1	3	1		
32-200/...	25	○	2	□	2	3	4	5	6	□	□	▲	▲	2	1	1	3	1		
32-250/...	25	○	3	□	□	3	4	5	6	□	□	▲	▲	3	1	1	4	1		
40-125/...	25	○	1	1	2	3	4	5	6	□	□	▲	▲	○	1	2	x	1		
40-160/...	25	○	1	□	2	3	4	5	6	□	□	▲	▲	○	1	2	3	1		
40-200/...	25	○	2	□	2	3	4	5	6	7	□	▲	▲	○	1	○	3	1		
40-250/...	25	○	3	□	□	3	4	5	6	7	□	▲	▲	○	1	2	4	1		
40-315/...	35	○	○	▲	▲	▲	8	9	10	□	□	▲	□	○	2	2	12	2		
50-125/...	25	○	1	□	2	3	4	5	6	□	□	▲	▲	○	1	3	3	1		
50-160/...	25	○	1	□	2	3	4	5	6	7	□	▲	▲	○	1	3	3	1		
50-200/...	25	○	2	□	□	3	4	5	6	7	12	▲	▲	○	1	3	3	2		
50-250/...	25	○	3	□	□	□	4	5	6	7	12	▲	▲	○	1	3	4	1		
50-315/...	35	○	4	▲	▲	▲	8	9	10	□	▲	▲	□	○	2	5	10	2		
65-125/...	25	○	1	□	2	3	4	5	6	□	□	▲	▲	○	1	5	3	1		
65-160/...	25	○	5	□	□	3	4	5	6	7	12	▲	▲	○	1	5	9	1		
65-200/...	25	○	○	□	□	□	4	5	6	7	12	▲	▲	○	1	5	9	1		
65-250/...	35	○	○	▲	▲	▲	8	9	10	11	13	15	14	○	2	9	12	2		
65-315/...	35	○	4	▲	▲	▲	□	9	10	11	□	□	□	○	2	9	10	2		
80-160/...	25	○	5	□	□	3	4	□	6	7	12	▲	▲	○	1	6	9	1		
80-200/...	25	○	6	▲	▲	▲	8	9	□	□	13	15	□	○	2	6	10	2		
80-250/...	35	○	7	▲	▲	▲	8	9	10	11	13	15	□	○	2	6	10	2		
80-315/...	35	○	4	▲	▲	▲	□	9	10	11	13	□	14	○	2	6	10	2		
80-400/...	55	○	10	▲	▲	▲	▲	▲	▲	▲	16	▲	17	○	3	○	○	3		
100-160/...	35	○	6	▲	▲	▲	8	9	10	11	13	15	▲	○	2	7	10	2		
100-200/...	35	○	6	▲	▲	▲	8	9	10	11	13	15	▲	○	2	7	10	2		
100-250/...	35	○	7	▲	▲	▲	□	9	10	11	□	▲	□	○	2	7	10	2		
100-315/...	35	○	4	▲	▲	▲	□	□	10	11	13	▲	14	○	2	7	10	2		
100-400/...	55	○	10	▲	▲	▲	▲	▲	▲	▲	16	▲	17	○	3	7	8	3		
125-200/...	35	○	8	▲	▲	▲	□	9	10	11	□	▲	□	○	2	8	11	2		
125-250/...	35	○	9	▲	▲	▲	□	□	10	11	13	▲	□	○	2	8	11	2		
125-315/...	55	○	11	▲	▲	▲	▲	▲	▲	▲	16	▲	17	○	3	8	8	3		
125-400/...	55	○	10	▲	▲	▲	▲	▲	▲	▲	16	▲	17	○	3	8	8	3		
150-200/...	35	○	8	▲	▲	▲	□	9	10	11	□	▲	□	○	2	○	11	2		
150-250/...	35	○	9	▲	▲	▲	□	□	10	11	13	▲	14	○	2	14	13	2		
150-315/...	55	○	11	▲	▲	▲	▲	▲	▲	▲	16	▲	17	○	3	14	8	3		

M	Колпак привода 341		
	Узел вала		
	25	35	55
71	f	—	—
80	1	—	—
90	1	—	—
100	2	4	—
112	2	4	—
132	f	f	—
160	3	6	—
180	3	6	—
200	7	8	10
225	—	9	11

M	Мощность		
	Узел вала		
71	.../024, .../034		
80	.../054, .../074, .../072, .../112		
90	.../114, .../154, .../152, .../222		
100	.../224, .../304, .../302		
112	.../404, .../402		
132	.../554, .../754, .../552, .../752		
160	.../1104, .../1504, .../1102, .../1502, .../1852		
180	.../1854, .../2204, .../2202		
200	.../3004, .../3002, .../3702		
225	.../3704, .../4504, .../4502,		

1) Только Etabloc со стандартным-двигателем

1	одинаковое число обозначает одинаковые детали	X	Детали не имеются в наличии	Y	сочетание данных насосов-/двигателей не возможно
○	различные детали	V	сочетание этих насосов-/двигателей по запросу	■	Детали взаимозаменяемы с Etanorm

Рекомендованный комплект запасных частей для 2-летней эксплуатации по DIN 24 296

Номер детали	Наименование-деталей	Количество насосов (включая резервные насосы)						
		2	3	4	5	6 и 7	8 и 9	10 и более
		Количество штук запасных частей						
210	Вал ¹⁾	1	1	1	2	2	2	20 %
230	Рабочее колесо (включая щелевое кольцо 502.2) ²⁾	1	1	1	2	2	2	20 %
230.1/.2	Рабочее колесо ³⁾ (Комплект)	1	1	1	2	2	2	20 %
400.1/.2	Плоские уплотнения ⁴⁾ (Комплект)	4	6	8	8	9	12	150 %
412.3	Уплотнительное кольцо-круглого сечения ³⁾	2	3	4	4	4	5	10 %
433	Торцовое уплотнение	1	1	2	2	2	3	25 %
502.1/.2	Щелевое кольцо ²⁾	2	2	2	3	3	4	50 %
523	Втулка вала	2	2	2	3	3	4	50 %
---	Плоское уплотнение	4	6	8	8	9	12	150 %

1) исключается для Etabloc G, M

2) исключается для Etabloc 25-20.1/... и 32-23.1/...

3) только для Etabloc 32-23.1/...

4) только для Etabloc 32-23.1/...



ООО КСБ
123557, г. Москва • ул. Пресненский вал, 27, стр. 12А
Тел.: +7 495 980 11 76, • Факс: +7 495 980 11 69
e-mail: info@ksb.ru • www.ksb.ru