



INSTRUCTIONS FOR INSTALLATION AND ASSISTANCE

NEREIX DATA CENTRALISATION AND ELECTRICAL POWER SUPPLY

NEREIX MASTER - Revision 3 of 03/2010





We thank you for the choice you've made and for the trust you've shown use.
The products in this manual are elements of a system generally composed of the thermal control unit, the distribution system (radiators, radiating panel system, fan coil units, etc.) and adjustment devices (thermostats, probes, etc.).
We recommend to scrupulously observe the instructions in this manual and the instructions of the other components.

INDEX

1	MASTER DEVICE.....	4
2	MASTER ELECTRICAL BOARD	5
3	MODEM	6
4	TYPICAL BUS CONNECTION LAYOUTS	7
5	BIDIRECTIONAL AMPLIFIER LINK	8
6	BUS CONNECTION	9
7	GENERAL BUS AND ELECTRICAL POWER SUPPLY LAYOUT	10
8	VERIFICATIONS ON BUS	11
9	GENERAL INFORMATION	11
10	WARRANTY	11

1 MASTER DEVICE

The Master device is a centralised unit for the reading and management of **NEREIX** zone modules. They are used for adjustment and heat metering for heating and DHW production systems.

After appropriate setting and configuration, the Master board enables to dialogue with the individual metering units, making possible:

- The download of consumption data of individual utilities.
- To highlight malfunctioning and alarms
- To send firmware updates to the slave boards and to the ICI KRONOS ambient controls,
- Remote system management by means of the GSM - GPRS modem
- To modify metering unit configuration parameters
- To read individual metering unit status
- To make motorised elements of the metering units function (pumps, valves, etc.)

For interaction with the device, see the dedicated software applications.

MASTER DEVICE CODE CB-1014

Complete Master board device and antijamming power supply filter

MASTER DEVICE WITH MODEM CODE CB-1032

Complete Master board device, antijamming power supply filter and GSM – GPRS modem
(figure below)

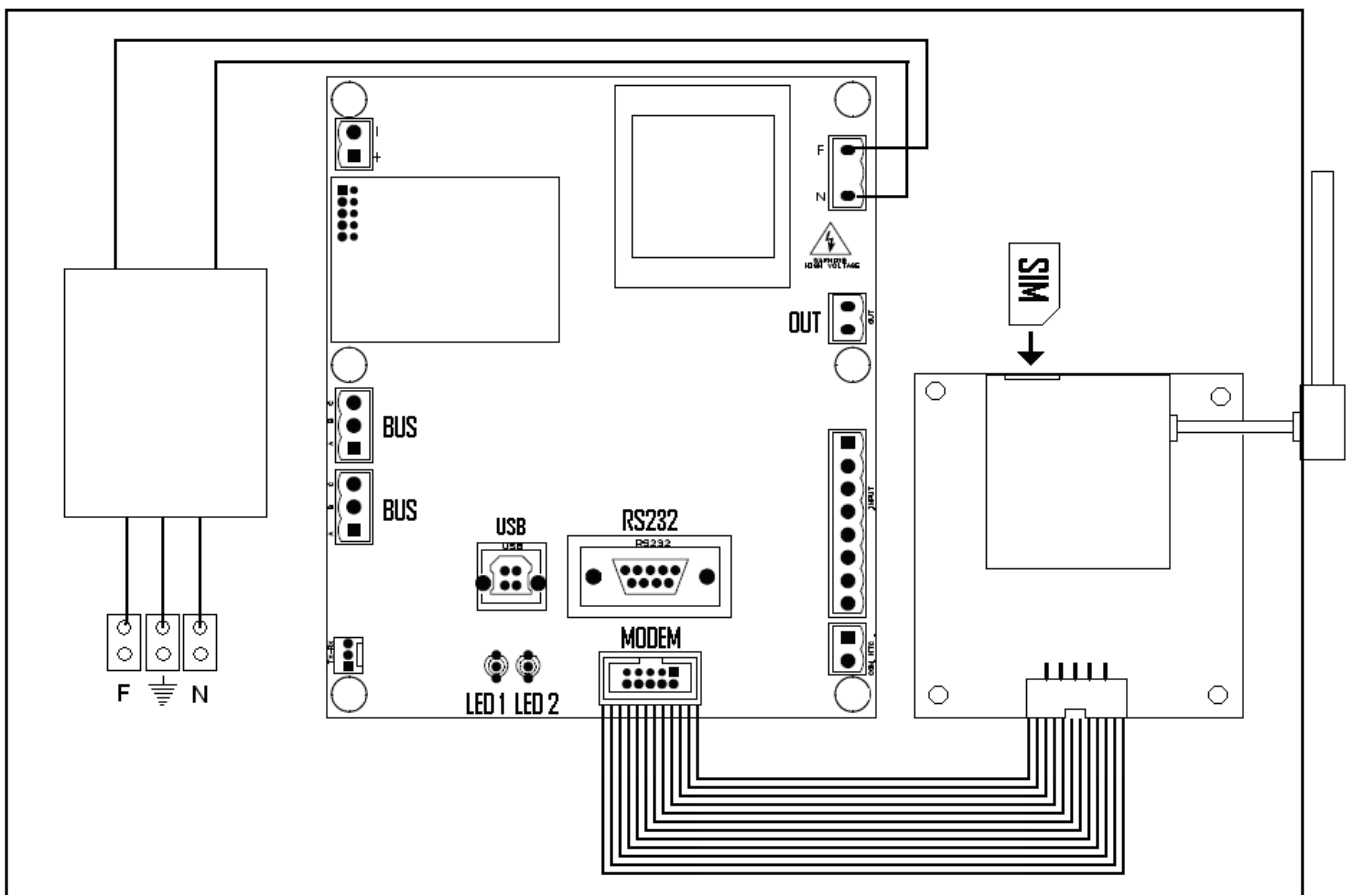

F=Phase N=Neutral

In order to supply a previously purchased CB-1014 device with a modem, ask for:

- Code CB-955 modem board
- Code CB-926 flat cable

It must be assembled by qualified personnel.

The GSM - GPRS modem is equipped as standard with an antenna to apply to the box. If reception is not sufficient where the device is installed, an antenna with a 10 meter extension is available (code CB-913).

2 MASTER ELECTRICAL BOARD

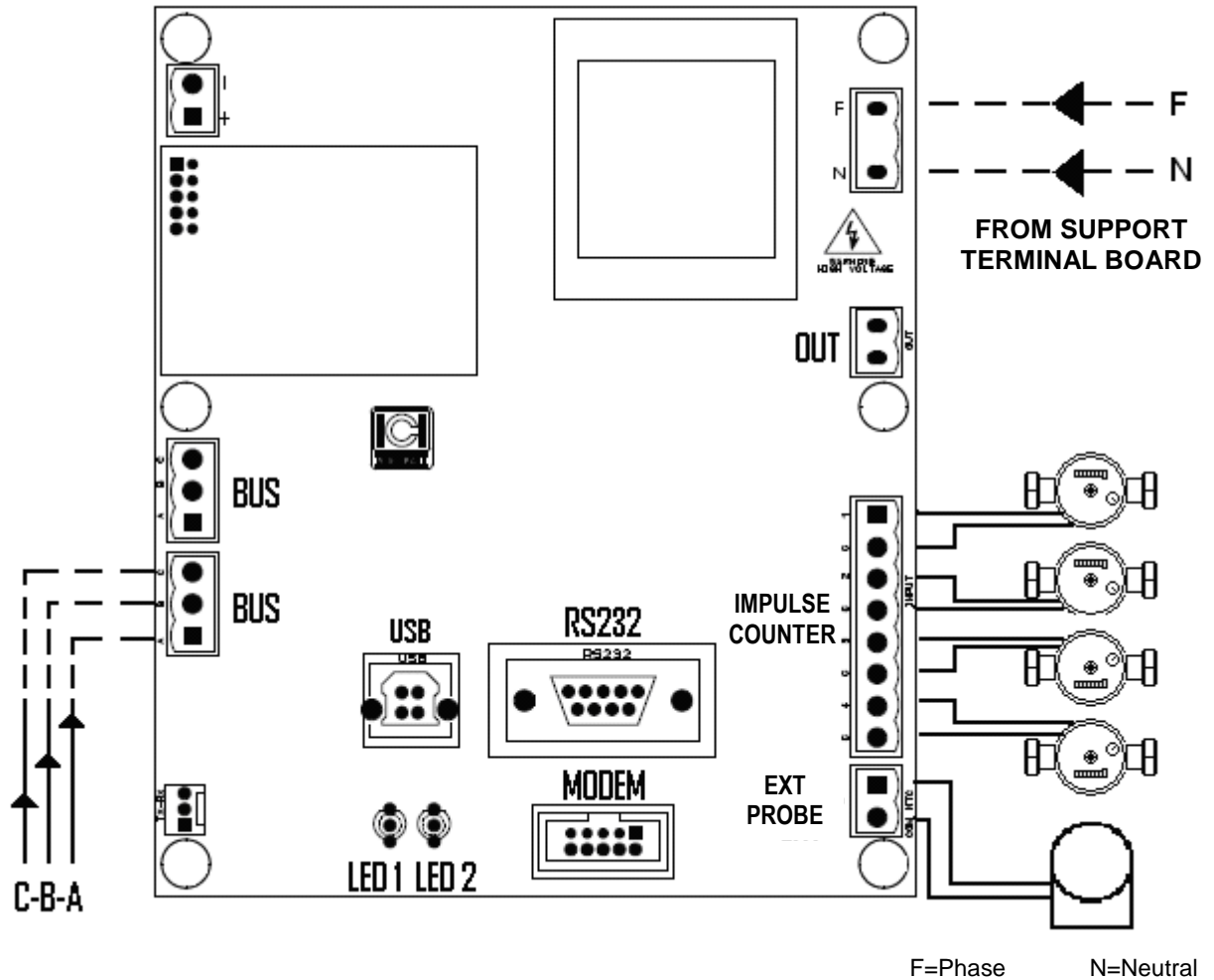

230 VAC POWER SUPPLY (P – N)

Connect the power supply (phase, neutral and earth) to the support terminal board

Important: as can be seen, the earth does not and **must not** be carried directly on the board.

On the board, the central pole between P and N **must not** be used.

DIGITAL OUTPUT (OUT)

this digital output (clean contact) is available for future ICI Caldaie S.p.A. software developments.

4 DIGITAL INPUTS (IMPULSE COUNTER)

4 volumetric meters with impulse output can be connected to these inputs.

EXT PROBE

an appropriate external probe (code 17120012) can be connected to this analogical input.

BUS (two parallel lines)

connections for the Bus lines coming from the **NEREIX** metering units.

Use both connection terminal boards if there are two bus "branches".

IMPORTANT INFORMATION ON THE BUS CONNECTION

- Respect the A and B polarity on the whole system
- Respect the layouts carried on the following pages
- Use a shielded and twisted 2 x 0.35 mm² cable
- Connect the screen to the Master board only (C terminals) and **not to the metering units** (slaves)
- There must be continuity on the screen even in correspondence with the metering unit input / output

FOR VERIFICATIONS ON THE BUS, SEE CHAPTER 8.

USB and RS232 CONNECTORS

allows board interfacing to a PC

MODEM CONNECTOR

allows the connection of the Master board to a specific optional GSM - GPRS modem (code CB 926)

LED DESCRIPTION

Every 10 seconds, the Master board interrogates all the boards to which it is connected.

Meaning of LED 1:

Green on flashing every 10”: The Master communicates with the slaves correctly.

Green on fixed: The Master is sending a configuration or a firmware.

Red on flashing: The Master does not find a board whose address it knows.

Meaning of LED 2:

Not used

3 MODEM

The module is connected (or must be connected) to the Master with the appropriate flat.

The modem is power supplied directly by the board, through the flat.

Cut power from the Master when connecting the modem and when inserting the SIM card.

The SIM card must be enabled to the data traffic (not the voice!!).

The SIM must be pushed to the end run: a “click” means it is inserted.

Before inserting the SIM, deactivate the PIN using a cellular phone.

Main features:

- GSM - GPRS Quad-Band MODEM
- LED for logging status to GSM network
- Buzzer for acoustic signalling
- TTL interface
- Compatible with NEREIX Master board

RADIO FEATURES

- Quad-band EGSM 850/900/1800/1900 MHz
- Emission output:
 - class 4 (2W) @ 850/900 MHz
 - class 1 (1W) @ 1800/1900 MHz
- Sensitivity:
 - 107 dBm (typ.) @ 850/900 MHz
 - 106 dBm (typ.) @ 1800/1900 MHz

GPRS FEATURES

- GPRS class 10
- Class B mobile station
- Coding layouts: from 1 to 4
- PBCCH support

The green status LED means:

- FAST FLASHING = Searching for the network
- SLOW FLASHING = Logged onto the network
- ON FIXED = Data connection in progress

In order to apply the optional antenna with the extension, remove the one as standard pulling the connector directly from the module connector and insert the new one.

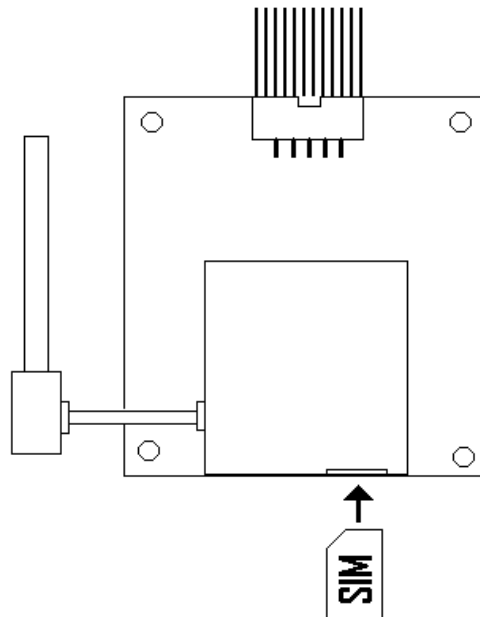

4 TYPICAL BUS CONNECTION LAYOUTS

IMPORTANT INFORMATION ON THE BUS CONNECTION

- Respect the A and B polarity on the whole system
- Respect the layouts carried on the following pages
- Use a shielded and twisted $2 \times 0.35 \text{ mm}^2$ cable
- Connect the screen to the Master board only (C terminals) and **not to the metering units** (slaves)
- There must be continuity on the screen even in correspondence with the metering unit input / output

SINGLE BRANCH SYSTEM WITHOUT AMPLIFIERS

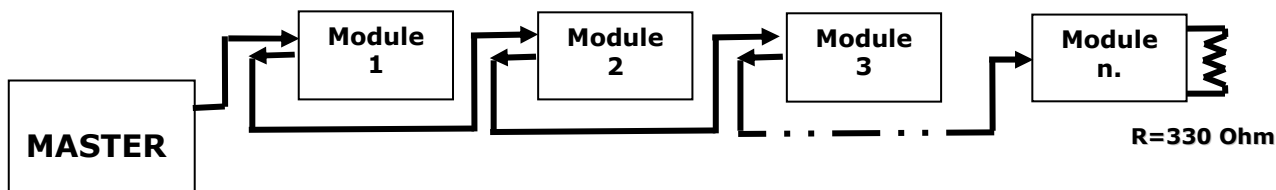

The overall length of the cable must not be more than 700 - 800 metres (indicatively).

Only the final slave must be "terminated" by a 330 Ohm resistance.

The 330 Ohm termination resistance must be placed between the terminals A and B of the last slave module

SINGLE BRANCH SYSTEM WITH AMPLIFIERS (OPTIONAL)

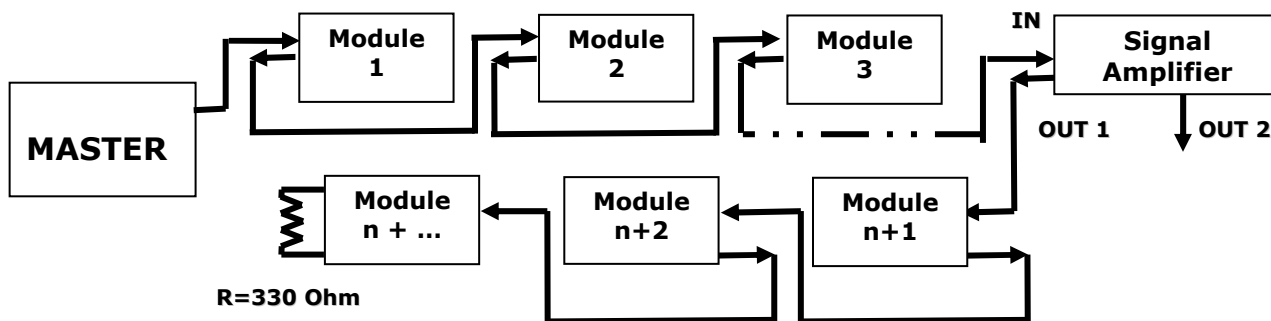

The overall length of the cable must not be more than 700 - 800 metres (indicatively).

Only the final slave must be "terminated" by a 330 Ohm resistance.

The 330 Ohm termination resistance must be placed between the terminals A and B of the last slave module.

MORE BRANCH SYSTEM WITH AMPLIFIERS (OPTIONAL)

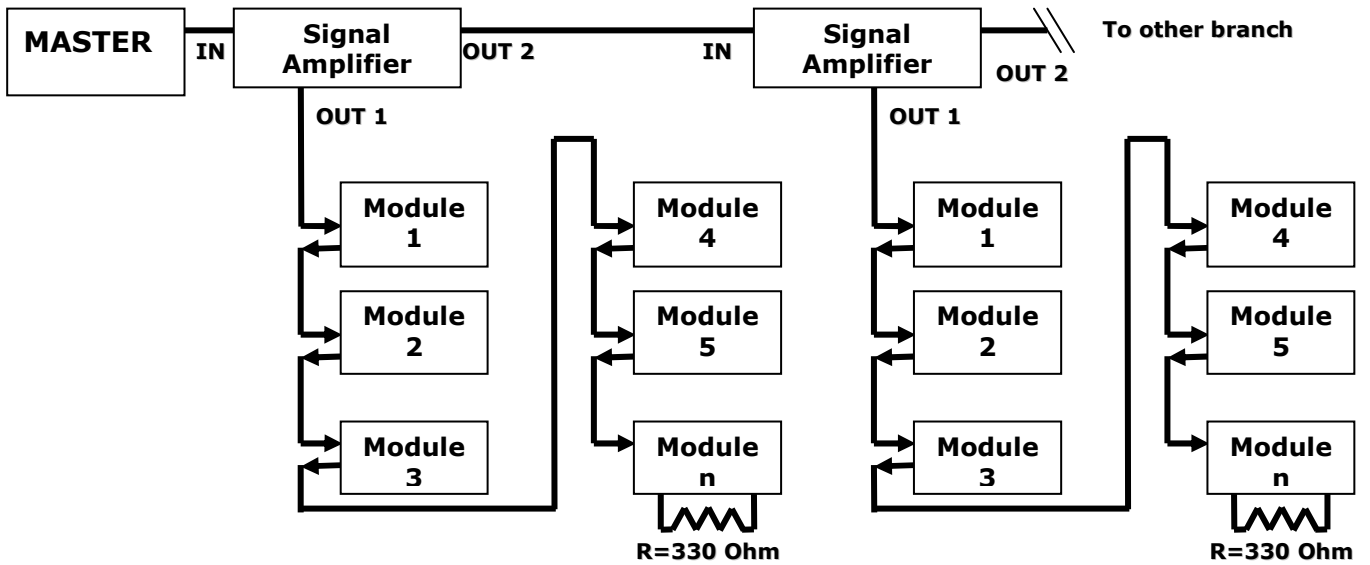

A signal amplifier must be installed on each branch after having overcome the length of 700-800 metres.
A 330 ohm resistance must be wired between terminal A and B on the last module after the signal amplifier.

5 BIDIRECTIONAL AMPLIFIER LINK

Connect the input and two output amplifier based on the type of scheme.
The amplifier must be powered at 230

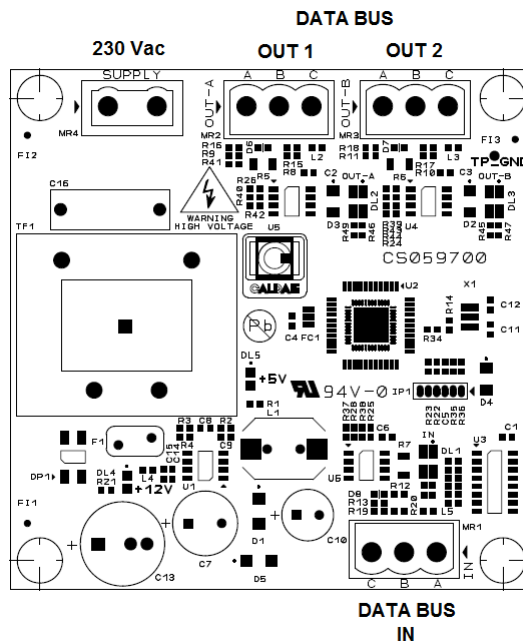

IMPORTANT:

Never connect the braid to the board. Use only terminals A and B.
Give continuity between the braids of the two lines.
The braids must be connected to the master and any amplifiers (Terminal C)

6 BUS CONNECTION

Depending on the model, there may or may not be a support terminal board.
 The layouts show boards in the middle of a bus branch and therefore they are wired with input and output cables.
 For a terminal board connection (with one input cable), it could be necessary to put a termination resistance between terminals A and B as well (see TYPICAL BUS CONNECTION LAYOUTS).

CLIMA BOARDS

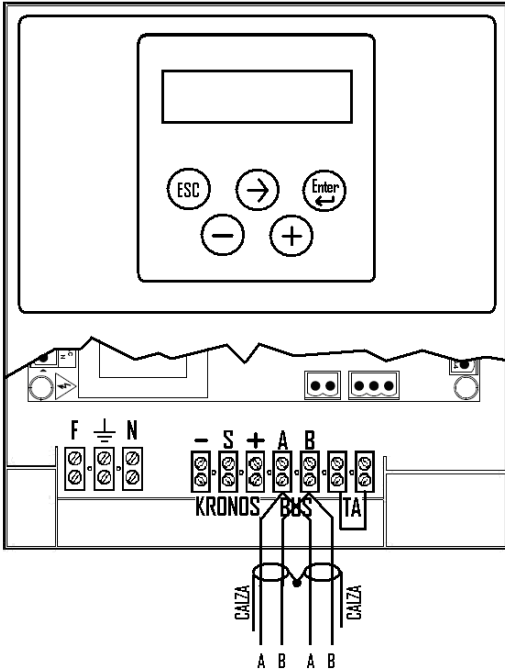

PANEL WITH SUPPORT TERMINAL BOARD

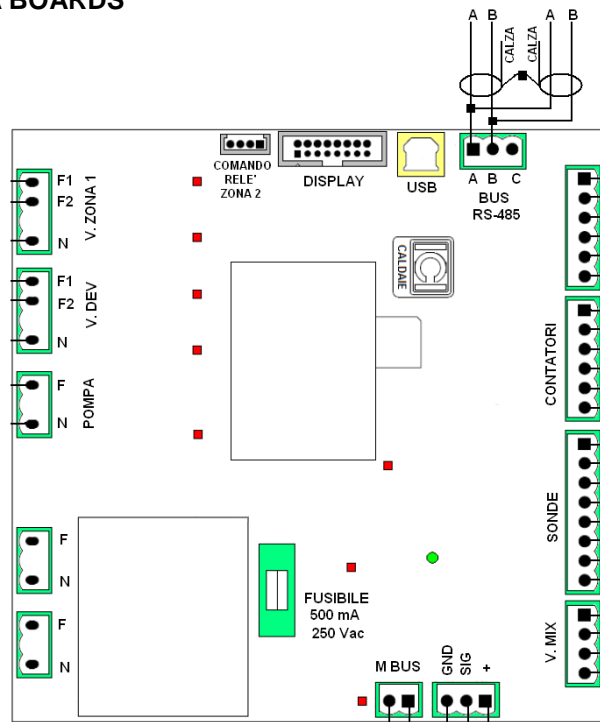

PANEL WITHOUT SUPPORT TERMINAL BOARD

HEAT METERING BOARDS

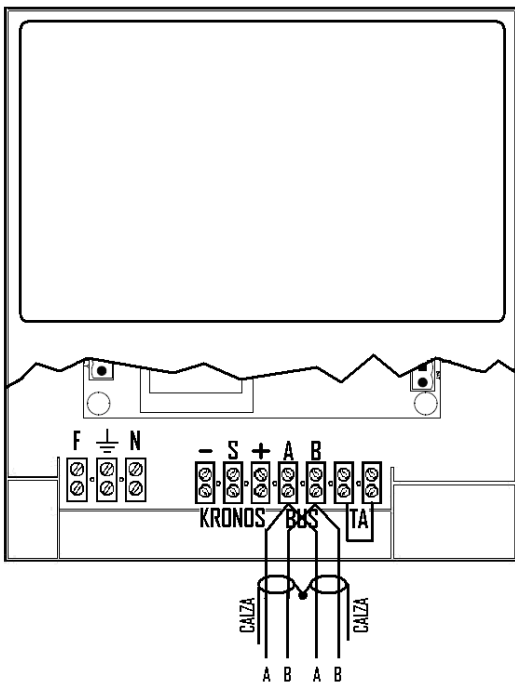

PANEL WITH SUPPORT TERMINAL BOARD

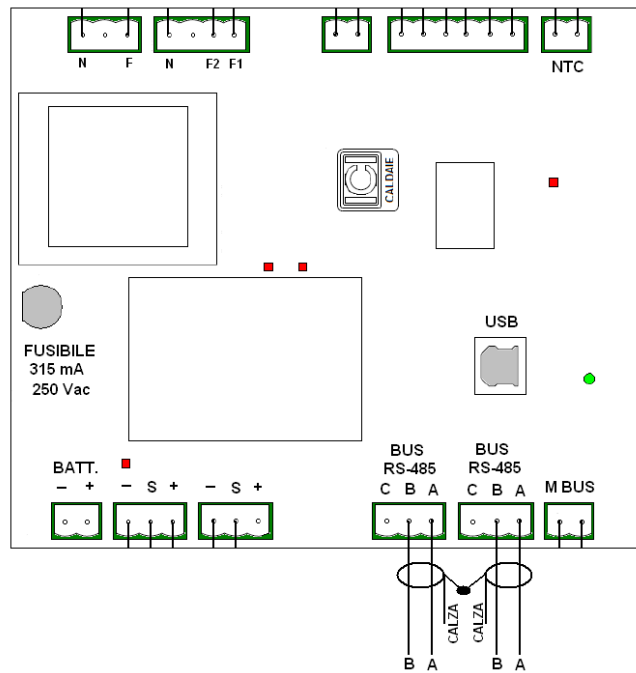

PANEL WITHOUT SUPPORT TERMINAL BOARD

Calza= Braid Pompa= Pump V. Dev.= Deviating valve? V. Zone 1= Zone 1 valve Fusibile= Fuse
 Comando relè zona 2= Zone 2 relay control Contatori= Meters Sonda= Probes V. Mix= Mixing valve

7 GENERAL BUS AND ELECTRICAL POWER SUPPLY LAYOUT

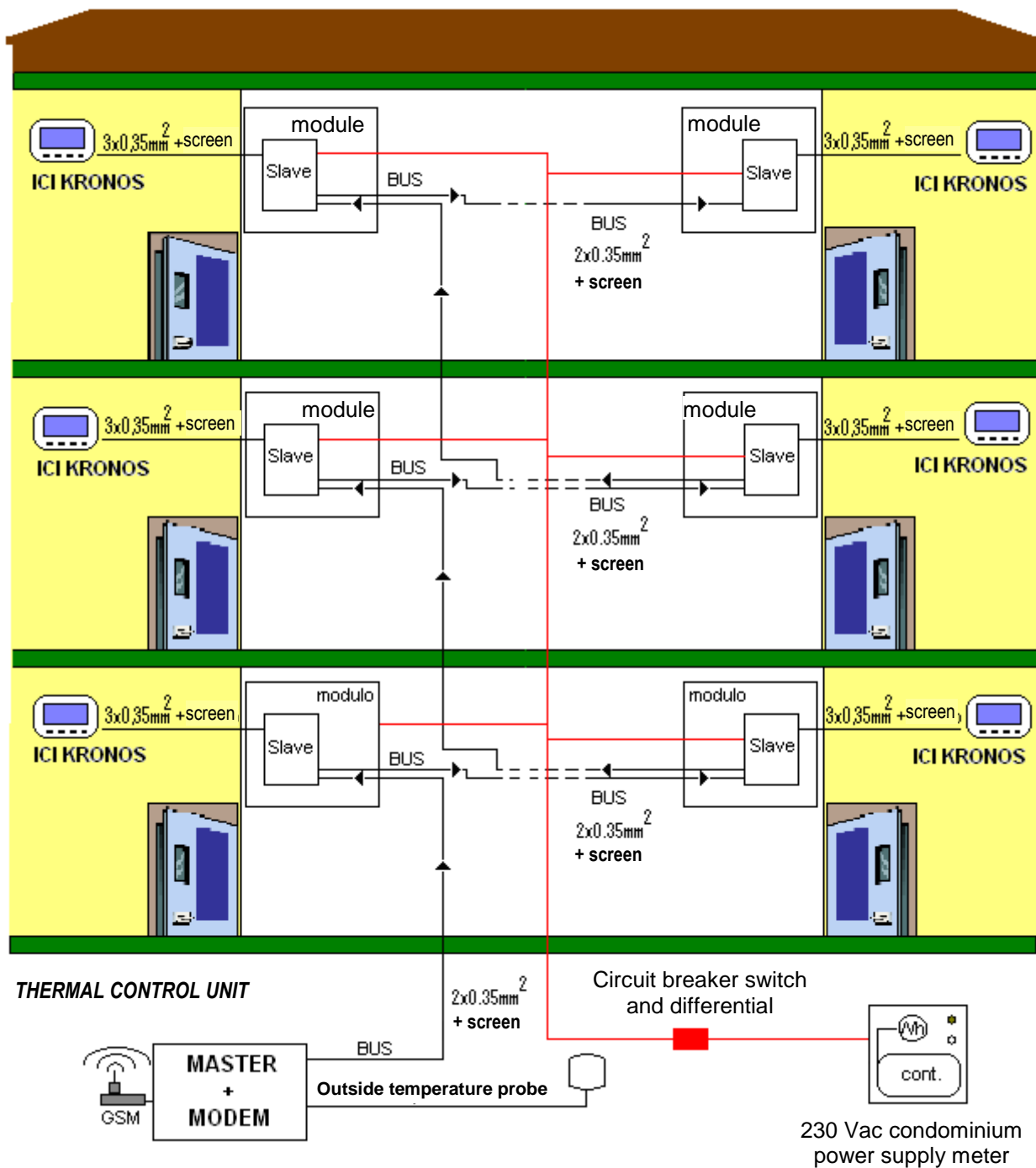

IMPORTANT: While wiring the Bus, remember that every branch and junction in the line entails signal decrease with potential communication criticality.

N.B. Place a circuit breaker switch at each single utility. It makes maintenance easier, allowing to switch off only the module that needs work.

8 VERIFICATIONS ON BUS

If there is no communication between the Master and slave board, voltage verifications can be carried out to see if there is a short circuit on the bus line or if a slave board does not work.

If the values indicated below are found, communication is not certain. However cable interruptions or that the cable is not well connected to the terminals can be excluded.

1) Normal bus voltage on branch	A – B:	0.0086 Vdc	and every 10”:	0.0270 Vdc
2) Normal bus voltage on branch	A – GND:	2.47 Vdc	and every 10”:	2.45 Vdc
3) Normal bus voltage on branch	B – GND:	2.46 Vdc	and every 10”:	2.48 Vdc
5) No-load voltage on slave board between	A – GND:	3.19 Vdc		
6) No-load voltage on slave board between	B – GND:	1.71 Vdc	and every 10”:	2.45 Vdc
7) No-load voltage o Master board between	A – GND:	2.47 Vdc	and every 10”:	2.48 Vdc

A minimum voltage threshold beneath which communication does not work cannot be set because the communication depends on the “steepness” of the front of the square wave ascent and this can only be seen with an oscilloscope.

9 GENERAL INFORMATION

For NEREIX metering units installed indoors place a dedicated circuit breaker switch in the electrical control board of the flat. This circuit breaker switch will be powered by the general differential of the flat.

For outdoor installation of NEREIX metering units, place a dedicated circuit breaker differential switch on the control unit's electrical control board (which powers the common services of the condominium).

The Master device is equipped with an antijamming filter.

The power supply must be 230 Vac (+10/-15 %).

Never place data transmission cables in the same corrugator as the power supply cables.

The BUS cables, as well as the chronothermostat or ICI KRONOS cables, can run in the same corrugator.

Every metal frame must be connected to the earth conductor.

Operating conditions

Operating room temperature	0 ÷ 50 °C
Storage temperature	-20 ÷ 60 °C
Relative humidity 1 (not condensing)	90%

10 WARRANTY

The warranty has value if good practice has been strictly observed for installation and use.

Our company is not liable for equipment breakdown and damage to persons and objects caused by:

- Transportation;
- Installation in which the Standards in force and good practice were not complied with;
- Improper use of the device, abnormal use conditions, tampering by unauthorised personnel or inadequate maintenance; therefore by:
 - lack of electrical energy; anomalies in the electrical system;
- Freezing or fortuitous causes;
- Wear due to normal use;
- Malfunctioning of control and safety parts;
- Corrosion due to oxygenation or roaming currents.



Belonging to Gruppo Finluc, registered R.I. VR n. 02245640236

Via G. Pascoli, 38 - 37059 Zevio - fraz. Campagnola - VERONA - ITALIA

Tel. 045/8738511 - Fax 045/8731148

info@icicaldaie.com - www.icicaldaie.com

The data in this booklet is supplied on an indicative and not a binding level for our company. The company can at any moment modify the models for ongoing improvement and a constant update.