



Operating manual
HOMA

Pump control
HSK15 / 25

Please follow safety guidelines in chapter 2

Version: 03 - 0.06_300704
SW-Version: 1.10c
HW-Version: 1.00
Date: 21.10.2004

Table Of Contents

1	Introduction	3
2	Safety guidelines	3
2.1	Marking of guidelines in the operating manual	3
2.2	To be observed	3
2.3	Application in the Ex – endangered areas	4
3	Load section	5
3.1	Main switch	5
3.2	Motor protection	6
3.3	RCD's (ELCB)	6
4	Function	6
4.1	Level measurement method	6
4.2	Pump control	6
4.2.1	Off – Automatic – On mode	6
4.2.2	Current measurement and ampere meter function	7
4.2.3	Thermo contacts	7
4.2.4	Run time monitoring	7
4.2.5	Special characteristics when operating two pumps	7
4.3	Fault messages and alarms	7
4.4	Operation and Displays	8
4.5	Rechargeable battery operation	9
5	Operation and Displays	9
5.1	Main menu	9
5.2	Main display	10
5.3	Pump operation mode	11
5.3.1	Change of pump operation mode using menus	11
5.3.2	Change of operation mode - additional keys	12
5.3.3	Change of operation mode by means of external switches	12
5.4	System menus and settings	12
5.5	Messages after starting the system	13
6	System menus	14
6.1	Level measurement	14
6.1.1	Level measurement setting	14
6.1.2	Zero adjustment	15
6.1.3	Filter	15
6.1.4	Minimum pressure	16
6.1.5	Cut-in, cut-out and alarm levels	16
6.2	Pump data	17
6.2.1	Run-on time	17
6.2.3	Pump rotation when using dual pump control	17
6.2.4	Time delay start when using dual pump operation	18
6.2.5	Rated pump current	18
6.3	Communication	18
6.4	Alarms	18
6.4.1	Alarm Auto Reset	21
6.4.2	Resetting alarms	22
6.4.3	Alarm relays 1 - 3	22
6.4.4	Mask Relays 1 - 3	22
6.4.5	Alarm buzzer	23
6.4.6	Allowed T1 alarms	23
6.4.7	High water alarm delay	23



6.5	General settings	23
6.5.1	Language selection	24
6.5.2	Changing password	24
6.5.3	Number of pumps	24
6.5.4	Time delay start	24
6.5.5	Short time start	25
6.5.6	Forced emptying	25
6.5.7	Date, time and SW-Version	25
6.6	System indications	26
6.6.1	Pump hour indication	26
6.6.2	Pump cycle counter	26
6.6.3	Deleting of hour meter / and cycle counter data	26
6.6.4	Supply and rechargeable battery voltage	26
6.6.5	Fault history indication	26
7	Switching behavior	27
8	Special functions	28
8.1	AUX inputs	28
8.2	External Off	28
8.3	External alarm	29
9	Fault messages	29
10	Standard settings	31
11	Setting and wiring guidelines	31
11.1	Pumps without a second thermo contact	31
11.2	Pumps with PTC	32
11.3	Operation with rechargeable batteries	32
11.4	Level sensor and float switch connection	33
11.5	Level measurement according to the impact pressure method	35
11.6	Voltage surge protection	35
12	Appendix	35
12.1	Example for fault codes in fault memory	35
12.2	General technical data	36
12.3	Wiring and connecting diagrams	37
12.4	Mounting	38

In case of questions and technical problems please contact:

 **HOMA Pumpenfabrik GmbH**
Industriestrasse 1
D-53819 Neunkirchen - Seelscheid
phone +49 - 2247 702 - 0
telefax +49 - 2247 702 - 339
<http://www.homa-pumpen.de>

Stand July 2003 - Technical changes reserved

1 Introduction

HOMA HSK is a modular pump control for up to two pumps, which has specifically been designed for use in the wastewater sector. The pump control measures and monitors the level of the medium and depending on the level, starts or stops either one or two pumps. In addition, the HSK continually monitors the built manual motor starters and the pump motor thermo contacts as well as phase sequence and phase drop. Other features include, integrated current measurement, hour meter and cycle counter as well as a flexible alarm messaging system.

The HSK pump controller is available in various configurations. This manual describes the control functions in detail.

Please note! All of the functions described in this manual may not be available on every pump control as this will depend on the configuration selected. The HSK15 control unit in particular, does not have all of the functions and features of the HSK25 pump control.

2 Safety guidelines

This operating manual exclusively describes the control unit section. It contains important references and warnings, and therefore should be read by the installer as well as by the relevant operator before installing and operating the unit.

Note! Not only should the general safety references mentioned in this “Safety guidelines” section be observed, but also any special safety references referred to in the other sections of the manual.

2.1 Marking of guidelines in the operating manual

Safety references contained in this operating manual, which can cause personal danger on failure to observe them, are



marked with this general danger symbol.



Warning against electric voltage is marked with this general danger symbol.

2.2 To be observed

The description and instructions in this operating manual relate to the HSK controls.

This operating manual does not take into account either all possible design details, styles or all possible coincidences and incidents, which may occur during mounting, operation and maintenance.

The CPS modular pump control is to be used by professionally trained personnel (see EN 50 110-1).

In such case that not all of the information and instructions are found in this operating manual, please ask the manufacturer, HOMA-Pumpenfabrik GmbH (address see page 2).

The manufacturer of this device takes no responsibility in case the operating manual is disregarded. This operating manual contains fundamental references which must be strictly observed during installation, operation and maintenance. Therefore, it is absolutely necessary that this operating manual be read before mounting and operation by the installer as well as by the appropriate qualified personnel / user and it has to be available at all times.

Not only the general safety guidelines mentioned in this main point "Safety Guidelines" section be observed, but also special safety references referred to in other sections of the manual.



Connecting and maintenance of the control may be carried out by qualified personnel only. Before opening the cover, make sure that the voltage is completely removed.

Before operating make sure that:

- the applied measuring method has been correctly selected in the control,
- the level sensor / float switch to be used are correctly connected,
- the thermo contacts of the pump are appropriately connected and not reversed,
- the current ranges and settings of the motor starter match the rated currents of the pumps,
- the connections have been executed properly and correctly,
- the control is correctly backed up.

Currently valid standards (EN, VDE, ...) as well as those of the local electrical board are to be observed. The OFF position of the internal switches is not be used in order to carry out maintenance of the pump(s). For this purpose, the main switch shall be used. The integrated manual motor starter can also be used (switch to 0-position and secure properly against renewed switching – for example by means of a padlock).

If the fuse of the control¹ is faulty, it should only be replaced by a fine fuse of the following types:
Si 3,15 AT (slow-blow 3,15A; 5 x 20 mm according to EN 60127-2/III)

2.3 Application in the Ex – endangered areas

In some cases, parts of the control device may be exposed to explosion endangered areas (as a rule zone 1 according to the EU –Directive 94/9/EG, **ATEX** 100a).

If the control device is operated on such a shaft, well etc., then the electrical circuits for the sensors (level sensor, float switches) must be intrinsically safe (e.g. by using an appropriate electrical (Zener) barrier). Only controls with appropriate ignition protection characteristics should be connected. The currently applicable standards concerning operating devices in explosion endangered areas shall be observed at all times.

The use of an open measuring system according to the impact pressure method in explosion endangered installations is permitted only with monitored aeration (bubbler system).

¹ The fuse of the control is located in the fuse holder on the lower left , next to clamps.

When the controller already features factory-installed isolating amplifiers and/or electrical (zener) barriers, then the permission documents and operating instructions are included with the switchgear and they must be adhered to. Particular attention to applicable regulations concerning wiring is to be paid! It is expressly pointed out that the it is the user's responsibility:



- to guarantee observance of the applicable regulations
- to carry out the installation in accordance with ATEX100a requirements
- to execute required inspections and documentation.
- to connect only appropriate and certified assembly units (like pumps, level sensors).

2.4 Additional documents

In addition to this operating manual and depending on the layout of the switchgear, further documents and manuals may be attached to this operating manual and they are to be observed:

- Clamp and wiring diagrams
- Documents for Ex-certified assembly units
- CPS documentation with telemetry functions (SCADA-Supervisory Control And Data Acquisition).

3 Load section

The load section of the control depends on the layout and the pump capacity. For this purpose reference is made to wiring and connection diagrams. In connection with the control, however, the following shall be observed:

3.1 Main switch

When the control is equipped with a main switch, then the control is switched on or off by means of the main switch. The enclosure cover can only be opened when the main switch is in the OFF position. The main switch has an emergency off function and it stops the pump(s). The master switch can be locked in the OFF position by means of a padlock.



Attention: The in-coming clamps of the main switch are live, even when the main switch is in the off position

Remark: If the control unit comes already equipped with a rechargeable battery, then the electronic system of the control continues to function as long as the battery is charged, even in case the main switch is turned off, however, the pumps can not be switched on. For further details see operation with rechargeable batteries.



Attention: If the control unit should not be equipped with a main switch, then this control unit shall be made voltage free before opening of the cover!

3.2 Motor protection

Depending on the layout of the control, each pump features a thermal overload relay or a manual motor starter. Setting of the current values is carried out directly on the thermal overload relay or on the manual motor starter and shall be in accordance with the pump data. The setting must be carried independently of the rated current settings of the electronic motor protection of the control unit. When the motor protection trips due to an overload, the fault is indicated in the display. After eliminating the problem, the manual motor starter or overload relay must be reset manually.

3.3 RCD's (ELCB)

The control unit may be equipped with one or two RCD's. When the RCD's trip, the pumps are switched off. Should the RCD's trip due to a fault current, it is displayed in the control. After eliminating the problem, the RCD(s) must be reset manually.

4 Function

4.1 Level measurement method

The control may be used for different level measurement methods:

1. External level sensor
 - measuring range from 0 ... 1m WC up to 0 ... 10m WC (adjustable);
 - 4... 20mA interface
 - additionally a float switch PSN as high water level monitor
2. Internal impact pressure measuring sensor
 - measuring range 0 ... 2 m WC
 - for connection to a wet bell using a pneumatic tube
 - additionally a float switch PSN as high water level monitor
3. Up to 4 float switches PSN

4.2 Pump control

The control can operate optionally with one or two pumps². Generally, the following can be said about the function: When an adjustable level is exceeded or the respective float switch switches, then the pump is switched on. When a level sinks under an adjustable value, then the pump is switched off after the set run-on time period (delay on break) elapses. When the control recognises a high water situation, then the pump remains switched on as long as this state is maintained. Simultaneously a fault message is given.

4.2.1 Off – Automatic – On mode

Apart from the above described automatic operation mode, each pump may be manually switched off or on by means of the operating keys or an external toggle switch. For details see Chapter 5.3

² Depending on the features, the operation with only one pump is possible as well.

4.2.2 Current measurement and ampere meter function

The control unit measures the current for each pump in a motor phase. The current is indicated in the display. Additionally, the current is monitored and thus an electronic motor overload relay is simulated. Undercurrent monitoring is also carried out.

4.2.3 Thermo contacts

As a general rule, waste water pumps feature one or two thermo contacts (Klixon) which trip at different temperatures. If the first thermal contact trips, a fault situation is given and the pump is stopped. In case the first thermo contact with the lowest temperature value trips, the pump will restart up to ten times after the thermo contact has cooled down. The allowable number of restarts is programmable. When the second thermal contact trips, this alarm is retained *zero-voltage safe* and it must be reset (if required) before the pump is released again. (see Chapter 5.4).

4.2.4 Run time monitoring

Additionally, the control monitors the run time of the pump(s). If the max. adjusted run time of a pump is exceeded, then an alarm is given. If 0 is set as max. run time value, then this function is deactivated.

Note: Run time monitoring also takes place in case of high water.

4.2.5 Special characteristics when operating two pumps

When operating two pumps, two different operation modes are to be distinguished:

- Alternating (or rotation) operation (1 / 1)
- Peak load operation (2)

When operating the control with two pumps, the pumps will operate on a rotation basis, that is, the pumps start alternatively so that, on an average, the load is evenly spread over the two pumps. In case of **peak load operation** the second pump has an additional on and off switching level. If the second cut-in level is exceeded or in case of high water, the second pump will additionally run as a peak load pump. To avoid a possible overloading of the mains supply, the second pump performs a delayed start according to the set delay time. In case of **alternating operation**, both pumps generally will not run at the same time. If a pump has caused a fault or if it has manually been switched off, the control unit will continue to work as a single pump control until the problem has been solved.

4.3 Fault messages and alarms

In addition to the above described fault messages assigned to the pumps, the control unit monitors whether the following faults have occurred:

- High water
- Phase drop or phase sequence
- faults in measuring technique (short circuit or wire breakage in the level sensor cable, inconsistent float switch status)

- loss of control voltage
- rechargeable battery voltage too low
- leakage monitoring
- additional "AUX" alarm of each pump
- "external" fault (only HSK25 in case of continuous level measurement)

Faults are signalled by means of a red LED, an internal buzzer, or with up to three voltage free alarm relays. The control unit features three alarm relays by means of which alarms can flexibly be given. Which alarm is signalled by which relay, as well as the polarity of the relay contacts are programmable. Using the internal terminal block, the relays can optionally be supplied with either 230V~ control voltage or with the internal 12V DC voltage.

4.4 Operation and Displays

For display purposes, the control unit features a two-line LCD-Display, 16 digits. The displays appear in clear-text in the selected country's language (English, French, Italian, Dutch or German). A green LED signals the unit is ready for operation, a red LED indicates faults. The operation of the unit is effected by means of three keys (▲, **OK**, ▼) (picture 2 below). Optionally, the control unit features additional keys or toggle switches for the 0-Hand-Automatic mode (picture 1 below).

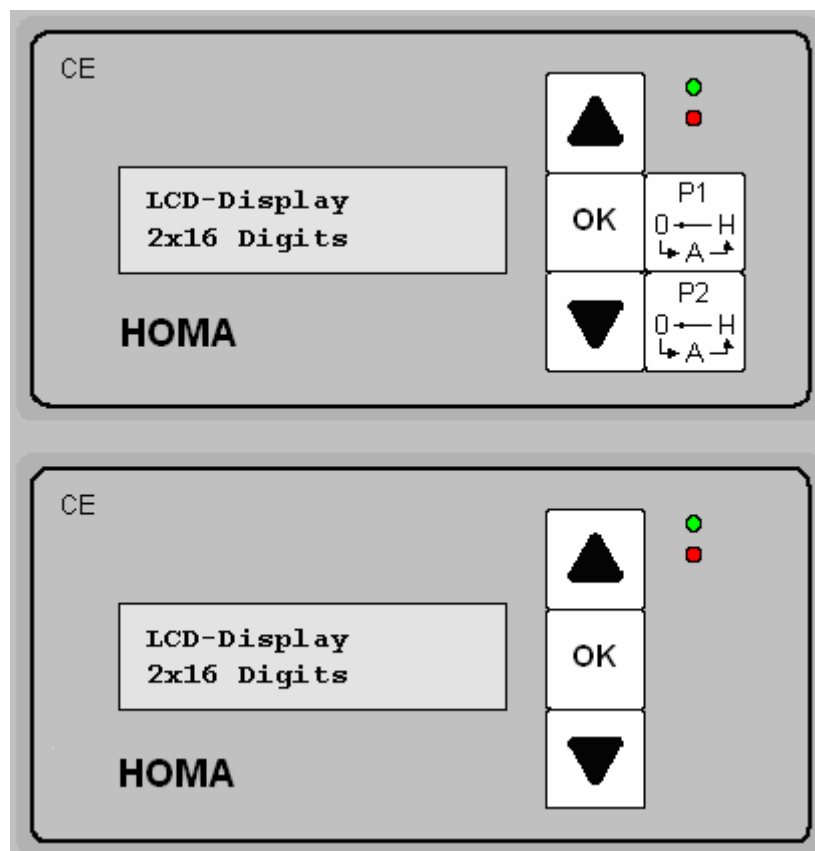

Operating the manual motor starters, RCD's or the main switch is effected by using the knobs of the respective device.

4.5 Rechargeable battery operation

The control unit can be operated with a rechargeable battery so that in case of a 230V~ control voltage loss the unit will continue to operate. The battery is recharged by the unit and can be used together with the potential free SPDT contacts of the alarm relay to give an alarm.

5 Operation and Displays

In this chapter, the operation of the control unit is described. Operation and display structure is organised in the **Main Menu**, in which displays and operation steps necessary for normal function are carried out and shown, and in **System Menus**, by means of which the control is parameterised. Each menu consists of a sequence of images in the LCD Display. Scrolling from display to display is effected by means of arrow keys (▲▼).

5.1 Main menu

The following diagram shows the menu structure of the control.

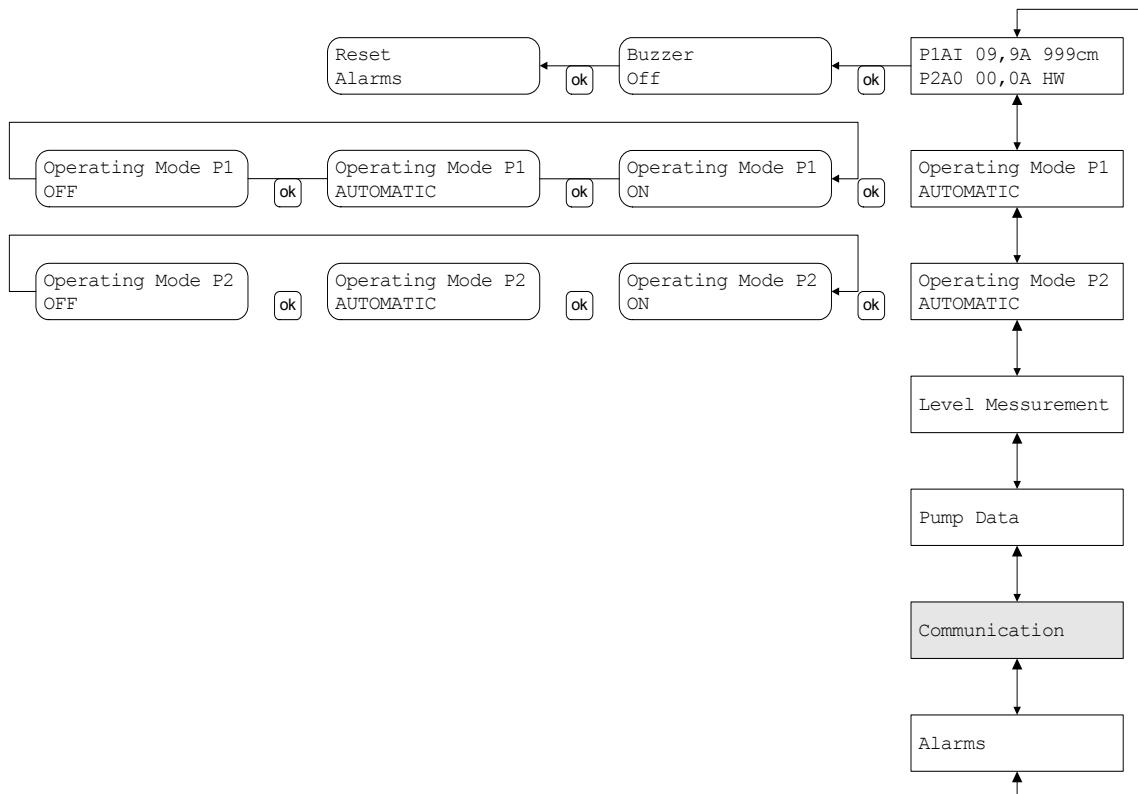

Using the arrow keys (▲▼) you can scroll up and down the contents of the menu. Using the **OK**-key

- the alarm buzzer in the **Main display** can be switched off and the alarms can be reset

- the operation mode of the pumps in the menu “**Operation mode**” can be changed,³
- one of the system menus can be selected

5.2 Main display

In the standard display, the control will indicate the operational state of the pumps, the current draw of the pumps and the measured level, e.g.:

P1:IA 5,7A 074cm
P1:0A 0,0A

Standard settings
see Chapter 7

The displayed values, however, depend largely on the status of the control as well as on the parameter settings and present fault occurrences. The different variants of indication are more precisely explained as follows:

Single pump operation

P1:IA 5,7A 074cm

Dual pump operation:

P1:IA 5,7A 074cm
P2:0M 0,0A

Pump P1 is running (I) in automatic operation mode (A), current draw 5,7 A, level 74 cm
Pump P2 is switched off (0) in manual operation mode (M), current input 0,0 A

Operation with one float switch

P1:IA 5,7A 0
P1:0M 0,0A

Operation with two floats

P1:IA 5,7A 1 0
P1:0M 0,0A

Operation with three floats

P1:IA 5,7A 1 0 0
P1:0M 0,0A

float 1 float 2 float 3
1: float switched on (above)
0: float not switched on (below)

³ When using CPS-Version with 4/5 operation keys or manual operation mode switches, the above menus are not present

High water indication

P1:IA 5,7A 074cm
P1:0A 0,0A HW

Failure in measuring system

P1:IA 5,7A ???cm
P1:0A 0,0A

Start delay

... 3sec 074cm

The start delay is effective (after the first initial start or after a mains voltage failure) or when the control has been switched off by the external input; both pumps are switched off. The indicated time period is the time period remaining before control unit restarts.

Pump faults / mains failure

In case of a pump fault or phase loss / incorrect phase sequence, the display flashes the indication as shown below alternatively along with the fault message, for example:

Fault
P1MS

(For further details on the fault indication, see Chapter 6)

other indications

After the control unit has finished its initialisation, in the lower right hand corner, a flashing triangle will indicate that the unit is using mains supply or by a flashing battery symbol in case the rechargeable battery is being used.

5.3 Pump operation mode

The operation mode for each pump can be changed between the operation modes: AUTOMATIC, manual ON and manual OFF. HSK is available in three types:

- Change of operation mode using menus
- Change of operation mode using additional control key(s)
- Change of operation using additional toggle switches

5.3.1 Change of pump operation mode using menus

In the menu "Operation mode", each pump can be changed to the operation modes: AUTOMATIC, manual ON and manual OFF. The change is effected by pressing the **OK**-key. The current state of operation is then indicated in the menu.



0M = Manual OFF

IM = Manual ON

0A = Automatic operation mode OFF

IA = Automatic operation mode ON

It is to be observed:

In case the pump is switched to the manual ON operation mode, this pump will only start if there is no fault present. If in a two pump operation mode, one pump is switched to OFF, the control continues to function as a single pump control, if the other pump is in the AUTOMATIC operation mode.

5.3.2 Change of operation mode - additional keys

By means of an additional key for each pump, next to the main control keys, each pump can be changed to the following operation modes: AUTOMATIC, manual ON and manual OFF. The change is effected by pressing the **OK**-key. The current state of operation is then indicated in the main menu.

0M = Manual OFF

IM = Manual ON

0A = Automatic operation OFF

IA = Automatic operation ON

It is to be observed:

In case the pump is switched to the manual ON operation mode, this pump will only start if there is no fault present. If in a two pump operation mode, one pump is switched to OFF, the control continues to function as a single pump control, if the other pump is in the AUTOMATIC operation mode.

5.3.3 Change of operation mode by means of external switches

By means of toggle switches fixed to the housing cover, the operation mode of the pump can be switched between operation modes: AUTOMATIC, manual ON and manual OFF.

Switching is effected electromechanically independent of the control and therefore it is also effective in case of control unit drop-out.

However, the function of the thermo contacts is guaranteed. It means that in case of opened thermo contacts (over-temperature) manual operation is not possible.

It is to be observed:

In case the pump is switched to the manual ON operation mode, this pump will only start if there is no fault present. If in a two pump operation mode, one pump is switched to OFF, the control continues to function as a single pump control, if the other pump is in the AUTOMATIC operation mode.

5.4 System menus and settings

Readouts of adjustment values of the control as well as change of operation parameters is effected in 5 submenus:

- Level measurement
- pump data

- communication
- alarms
- system indications

By pressing the **OK**-key the relevant submenus (system menus) can be accessed. Here, specific values can be viewed and/ or changed.

By means of the arrow keys (**▲▼**) scrolling from menu to menu is possible. By pressing the **OK** key in the menu point "back to main menu" the main menu is displayed again.

By pressing the **OK** key in all other menu points, the input mode of the respective menu point is accessed. The input mode is marked by a **└**-sign, in the LCD Display on the lower right hand side.

By means of arrow keys (**▲▼**), the values can be selected and by pressing the **OK** key the values can be changed. If entering a multi-digit number is required, the highest digit is changed first. With the **OK** key the next digit position is selected etc.

If a value needs to be changed, the **OK** key must be pressed first.

Before carrying out settings for the first time, however, a password must be entered. If, the OK key is pressed in a menu point for the first time, entering a password is requested:

Password:

Using the arrow keys (**▲▼**), a respective position within the password can be changed. Using the **OK** key, the next position up to the fourth position can be selected. If the valid password has been entered, in future, the adjustment values can be directly changed. The factory default password is 0000. If the wrong password has been entered, the message "false password" appears. Prompting of the password appears until the correct password has finally been entered. Once the correct password has been entered and confirmed by pressing the **OK** key, all setting values can be changed and the controller can be configured.

Should a key not be pressed for approx. 5 minutes, the control returns to the main display and the validity of the password expires. The password must be entered again.

5.5 Messages after starting the system

When the HSK is switched on, self checking of the program memory is conducted. A message "Checking ROM" is displayed. In case of a fault, the control unit is stopped and the fault message "contact service" is indicated. In case of this message, the CPS unit is not operable and for security reasons will not start.

When self checking is successful, a message is briefly displayed, for example:

Mode: 03EE

Modem: 0

This message is not important for the user and it indicates only the internal configuration for service purposes. Subsequently the copyright message with the SW-version number is indicated for approx. 1sec. After this, the HSK initiates the start delay time.

6 System menus

6.1 Level measurement

6.2 In the menu "Level measurement", the level measurement method, setpoints, high water levels as well as the minimum pressure (level measurement with bubbler system) are specified.

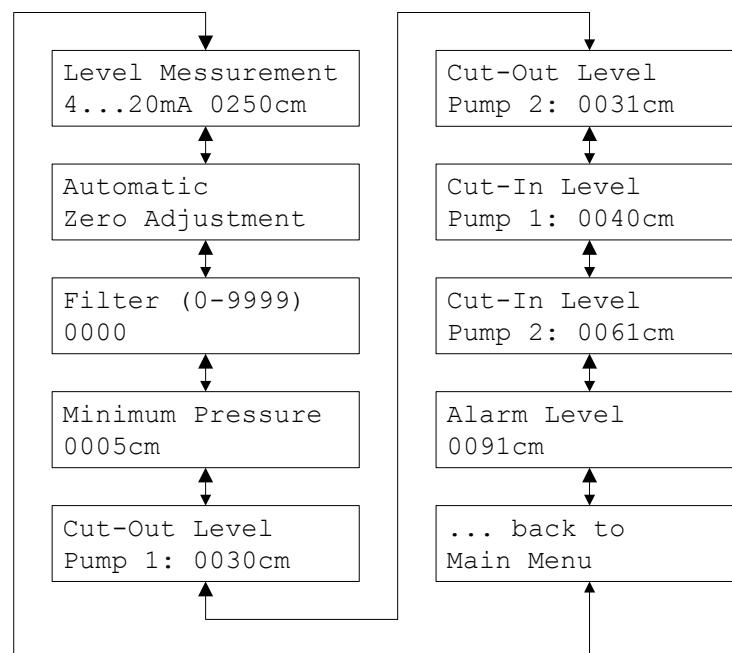

6.1.1 Level measurement setting

In this menu, the level measurement method is determined. After pressing the **OK**-key, the level measurement method can be selected by means of the ▲- or ▼-key. Following possibilities are available:

- level measurement 4... 20mA interface through level sensor, measuring range adjustable from 0100cm (1meter WC up to 1000cm (10 meters WC)
- internal impact pressure sensor (measuring range 0 ... 200 cm WC)
- 1 x float switch
- 2 x float switches
- 3 x float switches (only possible with **HSK25** in dual pump operation)

After the measuring method has been selected, it must be confirmed with the **OK**-key

If a 4-20mA level sensor has been selected as measurement method, then after pressing the **OK**-key, the measuring range of the connected sensor must be additionally entered in cm.

For example, for a HOMA LLS with measuring range of 2,5m - the value of 0250cm is entered.

Important information: If values for the measuring range < 0100cm are entered, then the control inserts the minimum value of 100cm , in case of values >1000cm, the control inserts the maximum value of 1000cm. If “3x float switches” has been selected and the unit is subsequently switched to a single pump operation, then the control unit switches automatically back to the measurement type - 2x float switches!

6.1.2 Zero adjustment

During level measurement it is of particular importance that zero point measurement be as exact as possible in order to minimise the risk of the pumps running dry. In this menu, therefore, the zero point of the level measurement can be exactly calibrated. Following remarks are to be observed:

During zero point calibration, the measuring device shall not be in the water, that is, the level sensor must be pulled out of the water. A working level sensor is to be connected. If the internal impact pressure sensor is used for measuring, the wet bell must be pulled out of water. Furthermore, it must be guaranteed that the measurement system is absolutely still during the zero calibration process.

After preparations in this menu point – zero adjustment, the **OK** key must be pressed, select "YES" using the ▲- or ▼-keys and confirm with the **OK** key. The automatic zero calibration is now initiated. In second row of the display, the unit's calculated correction value appears after a short time, Zero adjustment is herewith finished. This value is stored and is valid until the next zero adjustment is carried out. Zero adjustment can be repeated at any time. Should the control be operated with float switches, the zero adjustment menu will not be displayed.

6.1.3 Filter

In case of fluctuating water levels, level indication may fluctuate as well. This can be compensated by means of a low-pass filter and a more inert level registration can be adjusted.

0000 = Filter OFF

0001 = weaker (faster) Filter ... 9999 stronger (slower) Filter

If the control unit is operated with a float switch, the filter menu will not appear.



Note: When the filter is active, the level indication can be so inert that the measured level may deviate greatly from the level in the shaft.

The shaft may have already been emptied, the measured value, however, still indicates a level above the cut-out setpoints and the pump may possibly run dry. Therefore, pump capacity, setpoints, and filter values must be well in balance with each other.

6.1.4

Minimum pressure⁴

When a bubbler system is used, then the pump must produce a minimum pressure. This pressure can be monitored. When the level measurement falls below the adjusted pressure, a fault message is generated. Entering a value of 0000cm will deactivate minimum pressure monitoring. This function can also be used when a level should not drop below a given set point.

6.1.5 Cut-in, cut-out and alarm levels

In this menu, setpoints for the pumps are entered and displayed, for example:

Cut-out level 1.pump: 0030cm

For single and dual pump control in alternating operation mode, one pair of On and Off setpoints must be entered. For a dual pump control in peak load operation, two pairs of ON and OFF setpoints are required. Additionally, a high water setpoint must be entered.

For entering, press the **OK** key (on the lower right the ↵-sign appears).

Now, with the arrow keys, the value of the highest digit can be changed. Using the OK key, the next position is selected etc.

When entering the last digit is effected, on the lower left a ? sign may possibly appear (instead of the ↵-sign). This means that the selected setpoints are inconsistent, for example, a cut-out level is higher than a cut-in level. When the data is consistent, then the ? sign will not appear and the ↵-sign disappears after entering the last digit.

When the control unit operates with float switches, then setpoints are not shown.

⁴ When the control operates with float switches, the minimum pressure menu is not displayed.

6.2 Pump data

In this menu all pump relevant parameters are set . The menu has the following structure

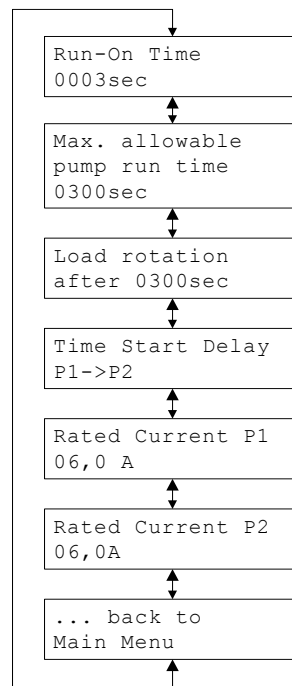

6.2.1 Run-on time

In this menu the run-on time is set (in sec). The run-on time is the time period, during which the pump(s) continue to run, after the level has fallen below the cut-out level. A value of 0000 deactivates this function.

6.2.2 Pump run time limitation

The run time of the pumps can be limited to a max. adjustable run time. If the pump runs uninterruptedly longer than the set time period, an alarm is given. In case of a dual pump control, rotation of the pumps is additionally effected. A value of 0000 deactivates this function.

6.2.3 Pump rotation when using dual pump control

In this menu point, the behaviour of the control concerning pump rotation can be determined. When entering a value of "0000", pump rotation is effected only after both pumps have been switched off. If a value between "0001" and "9998" is entered, then pump rotation is effected after both pumps have been switched off, at the latest after the set time period (in seconds) has elapsed. Entering a value of "9999" deactivates the pump rotation function, that is the control starts basically with pump 1 and pump 2 is always the peak load pump. **Note:** In the case of pump rotation function (1/1) and a value of "9999", pump 2 is never switched on automatically!



6.2.4 Time delay start when using dual pump operation

When the level exceeds the second upper setpoint or in case of high water, then both pumps run simultaneously under peak load operation mode. In order to reduce possible mains overload caused by the inrush currents of the pumps, the second pump is switched on after a time delay. The delay time can be set here. The time delay should be selected such that the second pump is switched on only after the inrush current of the pump 1 has dropped.

Note: This function is not effective in case the second pump has been switched on manually.

6.2.5 Rated pump current

For electronic current monitoring, the rated operating current of the pump must be set. If the current exceeds the rated value, an alarm is given after a certain time period. The more the current exceeds the rated value the shorter this time period is before an alarm is given.

If the measured current falls below half the value of the rated current, then an under-current alarm is given⁵.

In order to ensure a safe function, the entered value should be approx. 10%, that of the current showed in the display (under normal operation conditions).

Entering a value of 00.0A deactivates current monitoring. Current indication then is only that of an ampere meter.

6.3 Communication

This menu appears only, if the HSK features SCADA functions. The adjustment and setting possibilities in this menu point are described in a separate manual.

6.4 Alarms

In this menu behaviour of the control in case of faults is described. The menu has the following structure:

⁵ Not in case of HSK controls featuring manual 0-Manual-Automatic switch(es)

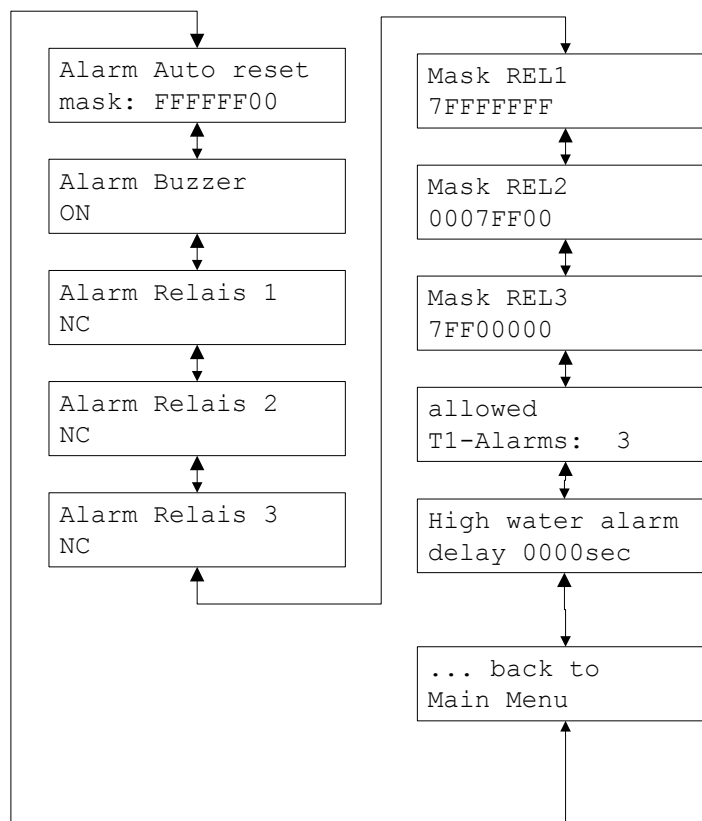

In some parts of the alarm menus, it is required that a “mask word” be entered. Here, the fundamental function, however, should be explained in advance. HSK can recognise up to 31 different errors. Further processing of these errors is controlled by the mask word. The mask word defines whether in case of a fault occurrence, the fault is assigned to one of the alarm relays⁶ (Mask Relays 1,2,3) or whether an automatic reset is enabled for the fault (Alarm Auto reset mask) respectively. Therefore, in all, four mask words must be determined.

In the control, each fault in a 32 bit binary number is allocated one bit. If the fault occurs, then this bit is set (1), otherwise its value is (0).

When a fault event is now to be signalled, for example by alarm relay 1, then in the mask this bit must also be set to (1). If the bit in the mask is set to (0), then the fault is recognised and processed in the control, but it is not transferred to the relay.

If, for example, only the high water bit is set in the mask, then only a high water fault is indicated by the alarm relay. For example only bits 9...20 which belong to pump1, can be allocated to relay 2.

⁶ The control unit HSK15 has 2 alarm relays, the control unit HSK25 has 3 alarm relays. *In case of HSK15, the menu points for the 3rd alarm relay do not appear.*



Due to the graphic limitations of the display, the single bits can not be entered as series of 32 zeros and ones.

Four bits at a time are compiled in a group (groups 1...8). In each group, four fault bits (0000, 0001, 0010, ... 1000) are coded, which must be compiled and must be converted into a hexadecimal digit (0,1,2,3,4,5,6,7,8,9,A;B;C;D;E;F) as shown in the table given below.

Example: In the first group the faults HW (0001), SENSOR (0010) and 3P (1000) are to be activated. Therefore the bits 1011 must be set. From the table, the hexadecimal digit "B" results as the mask value for the group 1.

For groups 2-8, the same procedure is carried out. The mask value is defined such that the determined eight hexadecimal digits are written one after another beginning from group 8 (left) up to group 1 (right). Thus a mask word is formed by 8 hexadecimal digits, which must be entered into the corresponding menu of the CPSm.

The input is effected analogous to the normal entering of numbers, with the only difference that after the 9 the "digits" A,B,C,D,E,F follow, resulting in a total of 16 possibilities for each "digit".

If, for example, only the faults of pump1 are to be activated, then all bits of the groups 8,7,6 must be (0000)=0_{HEX}. The bits of groups 3,4 must be (1111)=F_{HEX} and those of group 5 must be (0111)=7_{HEX}, the bits of the groups 1and 2 must be again (0000)=0_{HEX}. Therefore the fault mask is 0007FF00.

If, for example, only the faults aux1 and aux2 for each pump and the external faults are not to be used, then in groups 5 and 8, the resulting value is (0001) = 1_{HEX}, in all other groups the value (1111)=F_{HEX}. Therefore the mask word is 1FF1FFFF.

Bit	Fault short text	Group	Bit in Group	Fault	auto
General faults					
1	HW	1	0001	High water	x
2	SENSOR	1	0010	fault in measuring system	x
3	pmin	1	0100	Drop of pressure below the minimum set value	n
4	3P	1	1000	Wrong phase sequence, phase loss	x
5	Accu	2	0001	Rechargeable battery voltage too low	x
6	Power	2	0010	Mains loss (the controller runs on the rechargeable battery voltage supply)	x
7	Clock	2	0100	Fault – real time clock	n
8	Modem	2	1000	Communication fault	x
Fault pump 1					
9	P1T1	3	0001	Thermo contact 1 has tripped	x
10	P1nxT1	3	0010	Thermo contact 1 has tripped several times	n
11	P1T2	3	0100	Thermo contact 2 has tripped	n
12	P1MS	3	1000	Motor starter has tripped	x
13	P1FI	4	0001	RCD (ELCB) has tripped	x
14	P1DI	4	0010	Leakage fault	x
15	P1tmax	4	0100	Pump run time has been exceeded	x
16	P1Imin	4	1000	Pump current too low	x
17	P1Imax	5	0001	Pump current too high	x
18	P1aux1	5	0010	(reserved)	-

19	P1aux2	5	0100	(reserved)	-
external resetting of faults (only HSK25)					
20	external	5	1000	Input SCHW2 has switched	x
Fault pump 2 (only HSK25)					
21	P2T1	6	0001	Thermo contact 1 has tripped	x
22	P2nxT1	6	0010	Thermo contact 1 has tripped several times	n
23	P2T2	6	0100	Thermo contact 2 has tripped	n
24	P2MS	6	1000	Motor starter has tripped	x
25	P2FI	7	0001	RCD (ELCB) has tripped	x
26	P2DI	7	0010	Leakage fault	x
27	P2tmax	7	0100	Pump run time has been exceeded	x
28	P2lmin	7	1000	Pump current too low	x
29	P2lmax	8	0001	Pump current too high	x
30	P2aux1	8	0010	(reserved)	-
31	P2aux2	8	0100	(reserved)	-
32	---	8	1000	(not used)	x

Table Fault bits of the HSK

BIN	HEX	BIN	HEX
0000	1	1000	8
0001	1	1001	9
0010	2	1010	A
0011	3	1011	B
0100	4	1100	C
0101	5	1101	D
0110	6	1110	E
0111	7	1111	F

Conversion of group bits into a hexadecimal digit

6.4.1 Alarm Auto Reset

In this menu, the behaviour of the CPSm in case of faults can be adjusted. Here, two settings for each fault case are possible. AUTOMATIC reset (mask bit = 0) or MANUAL reset (mask bit = 1).

In the AUTOMATIC position, the fault indication is reset and the control continues to operate, when the fault is not present any longer.

In the MAN position, indication of all faults is maintained (with the exception of short-term high water).

In order for the controller to continue to operate, all faults must be reset on the controller.

Decide for each fault whether or not an automatic reset should be effected and determine the corresponding mask word as described above.

A recommendation for adjusting is given in the above table in the column "auto" (x = automatic reset; n = no automatic reset; - no recommendation, depending on application).



Security Note: The T2-alarm (thermo contact with higher tripping temperature) of controllers used in Ex-endangered areas should not be set to "Auto reset" .

6.4.2 Resetting alarms

When a fault (alarm) occurs, these alarms must be reset by pressing⁷ the **OK** key in the main display twice. The display shows “reset alarms” for approx. 1sec. and then returns to the main display.

In case of a fault and the **OK** key in the main display is pressed only once, then only the alarm relays and the buzzer are reset, however the fault indication in the display remains.

If an automatic reset has been activated, fault indication only disappears when the fault is not present any longer (for example, when the manual motor starter is switched on again).

6.4.3 Alarm relays 1 - 3

In this menu the type of alarm relay can be selected. In case of a fault, it can be determined whether the contacts are to be opened (NC = normally closed) or closed (NO = normally open) and additionally whether they are to flash. Four options are available:

- NC
- NO
- NC flashing
- NO flashing

This function can be individually selected for each relay.

This function is important in order to determine the behaviour of the controller in case of an alarm due to mains voltage loss. You can determine whether the alarm relay should remain in the alarm position or not. In this state, the relay is deactivated in any case, the NO relay contact is open, the NC contact is closed.

When the relay position is to be your alarm position then select NO, otherwise NC.

When the flashing function is additionally activated, then the relay switches on and off periodically at a clock rate of 1:2.

6.4.4 Mask Relays 1 - 3

In these menus, each alarm relay can be assigned which fault the alarm relay is to switch.

This allows free assignment of the relay function to a given fault status.

A set bit (1) means that the fault is assigned to the relay, in case of (0) the fault is not assigned to the relay.

In this way fault groups can be assigned to each relay, for example.

Relay 1 -> general faults
Relay 2 -> Fault Pump 1
Relay 3 -> Fault Pump 2

⁷ When the internal buzzer is active, pressing the key once deactivates the buzzer.

6.4.5 Alarm buzzer

In this menu, the internal alarm buzzer of the HSK can be switched on or off. If the buzzer is activated, an alarm is sounded in case of any fault occurrence.

6.4.6 Allowed T1 alarms

If during operation a T1 alarm frequently occurs (possible systematic fault), for example due to overload (thermo contact T1 trips), the controller can be prevented from automatically restarting again after the pumps have cooled down, upon reaching a certain number of fault alarms. The maximum number of T1 thermo contact tripping can be set in this menu.

Should a T1 fault, since last being reset, reoccur more often than set in the menu, the controller will stop and "nxT1" is shown in the display. n-1 is the number of T1-alarms. When this alarm mode is not required, then a value 0 has to be entered.

The assigned pump is switched off after exceeding the set number of T1 alarms, until the reset button has been pressed, only when:

The T1 fault in the "Alarm Auto Reset mask" has been set to 0 (automatic reset)

The nxT1 fault in the "Alarm Auto Reset mask" has been set to 1 (manual reset) have been entered.

6.4.7 High water alarm delay

If the high water level is exceeded or after the high water float switch trips, a delay time period can be set which must elapse before a high water alarm is given. Short-term high water levels, therefore will not lead to an alarm.

However, in the display, the high water message is immediately indicated as "hw". The waiting time can be recognised by the red flashing LED. If the set delay time period has been exceeded, then the LED shines continuously and "HW" is indicated.

6.5 General settings

In this menu, general settings of the controller are carried out. The menu has the following structure:

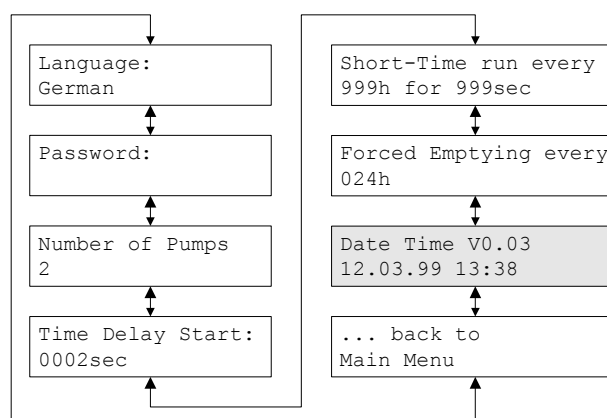

6.5.1 Language selection

In this menu, the language to be used can be selected. Selection is effected by the ▲- or ▼-key. The selected language is confirmed with the **OK**-key. All text messages appear in the selected language.

6.5.2 Changing passwords

In this menu the password of the controller can be changed⁸. After pressing the **OK**-key, the new password (4-digit number) is entered and the new password is confirmed once again in the second line. When both numbers match, then the new password is valid. The password should be noted and kept in a safe place otherwise, access to the system menu of the controller is not possible any more.



If the password is lost, then the controller must be re-configured by the manufacturer. For security reasons, changing of configurations without a password is not possible.

6.5.3 Number of pumps⁹

In this menu it can be determined, whether the control is to operate as a single or a dual pump control. After pressing of the **OK**-key, the number of pumps (1, 2, 1/1) can be selected by means of the ▲- or ▼-key. Following options are available:

- 1 one pump
- 1 / 1 alternating operation two pumps
- 2 peak load operation two pumps

Selection is confirm with the **OK** key.

6.5.4 Time delay start

After switching on the controller, the controller will not start immediately. The controller is activated only after the set delay time has elapsed. In case of a mains voltage loss or a phase sequence fault, the controller is activated only after the set time period. The delay time period is adjusted in seconds. Entering a value of 0000 deactivates this function.

If a value of 1000 is entered, then the delay time period (between 0 and 59 seconds) is randomly determined with each new start.

⁸ The factory default password is 0000

⁹ Only in case of a dual pump control HSK25; in case of a single pump control HSK15, this menu does not appear.

6.5.5 Short time start

In case pumps have not run for a long period of time, it may be desired to start the pumps regularly for a short time. By means of the short time start up, it is possible to start the pump every x hours for y seconds.

The values for x and y may be entered in this menu.

If the pump has not run during the set x time period, then this pump will start after the x time period elapses for a short time of y seconds.

If the pump has performed a normal run over the controller, then the counter sequence (x) begins to count again from 0.

6.5.6 Forced emptying

In installations which find little use, it may happen that the cut-in level is not reached over a long period of time. When level measurements are carried out by the impact pressure method, possible problems with the measuring system may arise, for example, through leaks. At the same time, it is sometimes not desirable to let waste water remain in the shaft over a long period of time.

With this function, the shaft can therefore be emptied if after the last pump run the cut-in level according to the adjusted time-period has not been reached. (A value of 000 deactivates this function).

Note: This function eventually demands that by means of the run-on time the shaft has been thus far emptied that the wet bell is hanging free (not under water).

6.5.7 Date, time and SW-Version¹⁰

Here date, the current time as well as the actual software version are displayed, for example

Date Time V1.10 21.05.99 14:45

(The colon in the indication flashes in second timing)

In this menu, the date and current time can be set. The setting is effected in the same way as the previous input of digits. Attention: The user must make sure that only valid time and date values are entered. Date and time are not required for normal operation of the controller. They are only used in order to save to memory the date and time a fault occurred and at the same time to enable improved analysis of faults.

The clock is monitored by the software. When the rechargeable battery of the clock is empty, faulty or not used, a CLOCK-fault is displayed when the control has not been used for a period of time and the clock was without current supply. The fault is also displayed, when the clock is not adjusted at least once after inserting a new rechargeable battery. With a new delivered CPS, therefore, the clock must be set in order to delete the CLOCK-faults.

¹⁰ Only for controllers with real-time clock, without real-time clock, this menu does not appear.

6.6 System indications

In the system indications menu the operation indications are displayed. The menu has the following structure:

6.6.1 Pump hour indication

In the menu point "Operating hours", the operating hours of the respective pump is displayed. The operating hours are counted when the controller switches on the pump. The indication is effected in hours (h) and minutes (min). Example for pump1:

Operating hours P1:004335h 45min

6.6.2 Pump cycle counter

In this menu point the number of On/Off cycles for each pump is displayed. Each time the pump is switched on, the counter is increased by one. Example for pump1:

Switching cycles P1: 0.000.950

6.6.3 Deleting of hour meter / and cycle counter data

By pressing the **OK** key in the respective menu, the pump counters are deleted. For security reasons, after pressing **OK**, the word "yes" must be entered and confirmed. When "No" is selected, then the counters are not deleted.

6.6.4 Supply and rechargeable battery voltage

In this menu, the rechargeable (ACC) and the internal control voltage (PW) are displayed. In the second line, a control value (EC:) followed by the word "POWER:" indicates whether the controller is supplied by the mains (plug symbol) or by the rechargeable battery (battery symbol). Entering values in this menu is not possible.

6.6.5 Fault history¹¹ indication

In this menu, the last 20 faults of the controller including date and the current time of when the fault(s) has (have) occurred can be traced. The fault memory works on a cyclic basis, that is, the oldest fault is overwritten after the 20th fault. The indication of the fault is effected analogously to the standard indication (see below). Individual faults can be browsed to a certain point of time by means of the ▼-key. The ▲-key is used to browse backwards in the fault events.

To leave the menu, press the **OK** key.

¹¹ Only in case of controllers with real-time clock, without real-time clock this menu does not appear.

7 Switching behavior

The switching levels determine when the pump(s) is (are) switched on or off. When the controller is operated using a continuous level measuring system (level sensor or impact pressure method), then the measured levels are directly processed and evaluated. When the controller operates with float switches, then the switching states of the floats determine whether the pump(s) are switched.

The following conditions must be fulfilled for consistent level values:

- The highest adjusted level must be lower than the adjusted measuring range of the level measuring system
- Single pump control, alternating dual pump control cut-out level of 1. pump < cut-in level of the 1. pump < alarm level
- Dual pump control (peak load operation): cut-out level of 1. pump < cut-out level of 2. pump < cut-in of 1. pump < cut-in level of 2. pump < alarm level

If during operation, a higher level is measured than the alarm level, then a high water alarm is given.

The following tables show the switching behavior of a dual pump control in peak load operation, a single pump control and a dual pump control in alternating operation under continuous level measurement and during operation with float switches respectively.

Level	Increasing	Decreasing	High water
	Pump 1	Pump 1	
Alarm level			
Cut-in level 1			0
Cut-out level 1	0		0
	0	0	0
	0	0	0

Switching behavior of the single pump control

Level	Increasing		Decreasing		High water
	Pump 1	Pump 2	Pump 1	Pump 2	
Alarm level					
Cut-in level 2					0
Cut-in level 1		0			0
Cut-out level 2	0	0			0
Cut-out level 1	0	0		0	0
	0	0	0	0	0
	0	0	0	0	0

Switching behavior of the dual pump control

Float switch state	Pump state 1
0	0

Switching behavior in one float switch operation

Float switch state		Pump state	
float 1	Float 2	Pump 1	Pump 2
0	0	0	0
1	0	1	0
1	1	1	0
All other states: sensor fault		0	0

Switching behavior in a two float switch operation with two pumps

Float switch state			Pump state	
Float switch 1	Float switch 2	Float switch 3	pump1	pump 2
0	0	0	1 -> 0	0
1	0	0	Unchanged	1 -> 0
1	1	0	0 -> 1	Unchanged
1	1	1	1	0 -> 1
All other states: sensor fault			0	0

Switching behavior in case of three float switch operation with two pumps

Float switch state			State
Float switch1	Float switch 2	Float switch 3	Pump1
0	0	Arbitrary	1 -> 0
1	0	Arbitrary	Unchanged
1	1	Arbitrary	0 -> 1
All other states: (sensor faults)			0

Two and three float switch operation with one pump¹²

Principally, following applies: When a cut-out signal is generated by either a change in level or by a change in the float switch state, the pump does not switch off immediately, but only after the set run-on time elapses.

8 Special functions

8.1 AUX inputs

Independently of the control, each pump can be switched off by an AUX input. In normal operation, the input must be bridged. If the input is open, then the corresponding pump is stopped and an AUX1 fault is recognized.

The function is independent of the control electronics and it affects the control circuit of the pump directly. This function can be used in order to switch off the pump by means of a coupling relay independently from the control or release the pump respectively.

8.2 External Off

Should the control not be operated with float switches, the controller has the possibility to stop the control unit using the input SW1. Both pumps switch off, when the input is closed. When the input is

¹² The operation with three float switches and one pump does not represent a sensible mode of operation.

open again, then the controller starts with the set time delay. If this function has been activated, then "external OFF" appears in the second line of the display.

8.3 External alarm¹³

Should the controller not be operated with float switches, the possibility to give an external alarm using the SW2 input is given. When the input is closed, then the external alarm is generated. This is also indicated in the display. The switching behavior of the pump(s) is not affected by this alarm. The alarm message, however, as well as all other alarms, can be reported further through the alarm relay or, it can be messaged further through the communication device (modem / SMS), when there exist.

9 Fault messages

When the control recognizes a fault, then the alarm is produced and the fault is indicated. Following faults are recognized and processed:

Bit	Fault code	Fault
1	HW	High water. When the measured level is above the adjusted alarm level or the high water float switch switches, then this fault message is released after the alarm delay time has elapsed. The pump(s) are switched on immediately in case of high water, when the pump(s) are in a fault-free condition.
2	SENSOR	Fault in the measuring system A fault has occurred in the level measuring system. (short circuit or wire breakage of the level sensor, inconsistent switching states of the float switches). The pumps are switched off. When the high water float switches, however, then the pumps are switched on when the pump(s) are in a fault-free condition.
3	pmin	Pressure below the minimum value During level measurement using the internal impact pressure sensor, the alarm is released when the pressure falls below the minimum value.
4	3P	Phase sequence / phase loss Mains or phase sequence fault. This fault occurs, when phase connection to the controller has been carried out incorrectly or when there is a loss of at least one of the phases.
5	Accu	Rechargeable battery voltage too low The rechargeable battery voltage of the controller is below 0.5 V. The rechargeable battery is not correctly charged yet or it is operating in an almost empty state.
6	Power	Lack of mains voltage The controller does not have a control voltage; the controller runs with the rechargeable battery, if one is integrated.
7	Clock	Fault – real time clock The clock was without power (current) supply over a longer period of time and the date / time could be incorrect / The clock does not run / The clock has not been adjusted yet after inserting a new rechargeable battery.
8	Modem	Communication fault There is a fault in the data communication. For details see separate manual.
9	P1T1	Thermo contact 1 has tripped The first thermo contact of the pump1 has tripped. The pump is switched off. If AUTO in the menu "Alarm Reset" has been selected, then the controller will restart again automatically after the pump has cooled down.
10	P1nxT1	Thermo contact 1 has tripped several times The first thermo contact of the pump has tripped "n" amount of times. The pump will be switched off. This fault should be reset on the control panel.
11	P1T2	Thermo contact 2 has tripped The second thermo contact of pump 1 has tripped. The pump is switched off. This fault should be confirmed on the controller. This fault is also saved to memory after power loss and is 0 voltage safe.

¹³ only with HSK25

12	P1MS	Motor protection has tripped The manual motor protection of the pump 1 has tripped. The pump is switched off. If AUTO in the menu "Alarm Reset " has been selected, then the controller automatically restarts after switching the manual motor starter on again.
13	P1FI	RCD (ELCB) has tripped The RCD of pump 1 has tripped. The pump is switched off. If AUTO in the menu "Alarm Reset " has been selected, then the controller automatically restarts after switching the RCD on again.
14	P1DI	Leakage fault Leakage monitor of pump 1 has signaled a fault (optional).
15	P1tmax	Exceeding pump run time The maximum allowable run time of the pump has been exceeded.
16	P1lmin	Pump current too low The electronic motor protection measures a motor current on pump 1, that is lower than half of the motor rated current.
17	P1lmax	Pump current too high The electronic motor protection of pump 1 has tripped because the current was exceeded. The pump is switched off. . If AUTO in the menu "Alarm Reset" has been selected, then the controller begins to operate automatically again after the waiting time.
18	P1aux1	AUX1-fault The contacts AUX11 and AUX12 at the terminal block are not connected (open) P1 is switched off. If required, the pump can be switched off by means of an auxiliary relay.
19	P1aux2	(reserved)
		Remark: Fault Bits 20 – 31 only in with HSK25
20	Extern(al)	External alarm The input SW2 (not in case of float switch operation) is closed.
21	P2T1	Thermo contact 1 has tripped The first thermo contact of pump 2 has tripped. The pump is switched off. If AUTO in the menu "Alarm Reset" has been selected, then the controller will restart again automatically after the pump has cooled down.
22	P2nxT1	Thermo contact 1 has tripped several times The first thermo contact of the pump has tripped "n" amount of times. The pump will be switched off. This fault should be reset on the control panel.
23	P2T2	Thermal contact 2 of pump 2 has tripped The second thermo contact of pump 1 has tripped. The pump is switched off. This fault should confirmed on the controller. This fault is also saved to memory after power loss and is 0 voltage safe.
24	P2MS	Motor protection of the pump 2 has released The manual motor protection of pump 2 has tripped. The pump is switched off. If AUTO in the menu "Alarm Reset " has been selected, then the controller automatically restarts after switching the manual motor starter on again.
25	P2FI	RCD (ELCB) of pump 2 has tripped The RCD of pump 2 has tripped. The pump is switched off. If AUTO in the menu "Alarm Reset " has been selected, then the controller automatically restarts after switching the RCD on again.
26	P2DI	Leakage fault of pump 2 Leakage monitor of pump 2 has signaled a fault (optional).
27	P2tmax	Exceeding run time of pump 2 The maximum allowable run time of the pump has been exceeded.
28	P2lmin	Pump current of pump 2 too low The electronic motor protection measures a motor current on pump 2, that is lower than half of the motor rated current.
29	P2lmax	Pump current too high The electronic motor protection of pump 2 has tripped because the current was exceeded. The pump is switched off. If AUTO in the menu "Alarm Reset" has been selected, then the controller begins to operate automatically again after the waiting time.
30	P2aux1	AUX1-Fault The contacts AUX11 and AUX12 on the terminal block are not connected (open) P2 will be switched off. If required, the pump can be switched off by means of an auxiliary relay.
31	P2aux2	(reserved)
32	---	not used

In case of all faults, both alarm relays switch according to the above mentioned settings, the integrated buzzer sounds (if activated) and the red fault LED will light up. If there is only one flood alarm and the alarm delay time has not elapsed yet, then the red LED flashes.

There are three (HSK25) or two (HSK15) voltage free relays (SPDT) as alarm outputs available.

10 Standard settings

The control is delivered with the following factory standard default settings:

Parameter	Value	Parameter	Value
Number of pumps	2	Start time delay	3 sec
Measuring method	Level sensor	Load rotation after	0(Off)
Minimum pressure	0 cm	T1-Alarm after	3 x
Cut-out level Pump 1	10 cm	Alarm buzzer	ON
Cut-out level Pump 2	20 cm	Alarm relay 1	NC
Cut-in level Pump 1	40 cm	Alarm relay 2	NC
Cut-in level Pump 2	60 cm	Alarm relay 3	NC
(High water) Alarm level	90 cm	Delay time P1-> P2	4sec
Run-on time	3 sec	Auto reset mask	04604640
Short time run every	48h	Mask Relay 1	7FFFFFFF
Short time run period	3 sec	Mask Relay 2	0007FF00
Forced emptying every	24h	Mask Relay 3	7FF00000
Maximum run time	0 sec	HW delay (high water) Alarm	0 sec
Password	0000	Grey background : not available for HSK15!	
Language	German		

11 Setting and wiring guidelines

11.1 Pumps without a second thermo contact

Some pumps feature only one thermo contact. Should this be the case, then this thermal contact is to be connected to the inputs of the T2-contacts (TM and TH). The T1-contact of the controller is also to be bridged (TL and TM).

Some pumps with two thermal contacts feature only three wire connection. The common conductors of the thermo contacts is the center connection TM, of the connecting terminals.

In case of individual contact lead out, each connection of the contacts is to be jointly connected to TM.

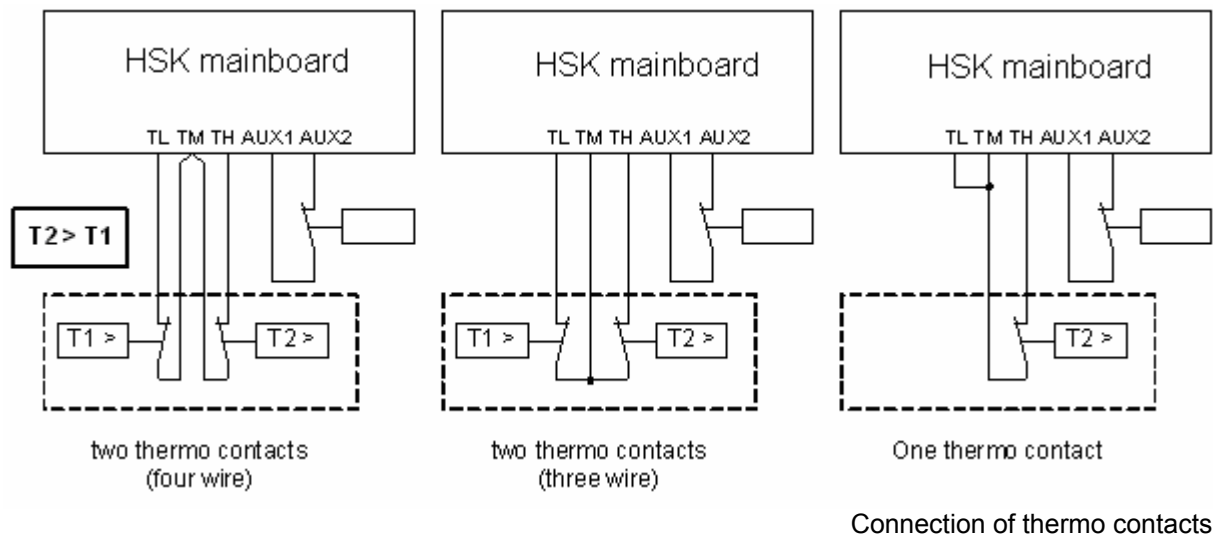

11.2 Pumps with PTC

In such cases where pumps feature a cold conductor (PTC) to monitor temperature, the conductor

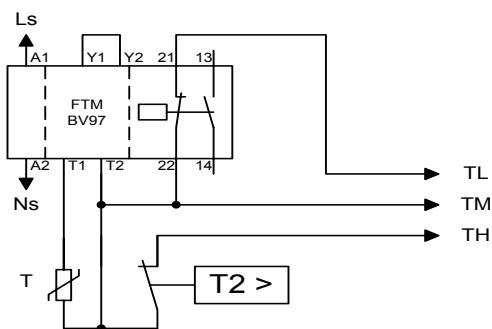

must be connected to a PTC motor protection relay (for example Scharco FTM BV97-230V). It is recommended to adjust the relay for automatic reset and to carry out the alarm reset on the control panel. The output relay has to be connected such that the contacts are opened in case of a fault. The example on the left shows connection for one pump with a PTC and a thermal contact.

11.3 Operation with rechargeable batteries

In case of mains voltage loss, the controller will continue to function.

For security reasons the pump relays, however, are switched off (= Pumps OFF).

When operating with a rechargeable battery, the operation is indicated by a blinking battery symbol instead of a flashing triangle.

The operating time when using a rechargeable battery, when fully charged, is approximately 10 hours (alarm relay deactivated, no modem).

The rechargeable battery voltage is available at the 12V terminals, for example, for operating of a beacon.

Attention: Depending on the load, the operating time, however, could be significantly shorter!

In case of control voltage loss, first the fault message "POWER" is generated and the control continues to operate. When the rechargeable battery voltage falls below approx. 10,5 V, then additionally the fault message "ACCU" is generated. At this point of time, all relays are deactivated in order to keep the load on the rechargeable battery as low as possible. Data communication, however, is still possible. When the voltage falls below ca. 9,5V, the control goes in the stand by mode. The following message is displayed:

-- Stand-by --

ACC 09.1V PW 00.0V

(in the second line the measured rechargeable battery voltage and the internal control voltage are displayed).

The control shall continue to operate only when the rechargeable battery voltage or the control voltage have reached their rated values again.

It takes approx. 50h until the rechargeable battery is charged.

A lead gel battery with a rated voltage of 12V /1,2Ah is used.

It is not allowed to use any other type of batteries, because the recharging circuit has been laid out for lead gel batteries. Under low temperatures, the capacity of the battery decreases.

Remark: *If the control is not to be operated for a longer period of time, then the battery pack should be disconnected. To this aim remove the cable from the + terminal of the battery.*

Caution: *the removed terminal should not touch any other conductive parts!*

Attention:

Protect the battery pack against deep discharge!

Short circuit of the battery shall be prevented at all times!

11.4 Level sensor and float switch connection

When the control is operated with an internal level sensor, then it has to be connected to the connections of level 1. A possible high water float switch has to always be connected to the SWHW input. When the control is operated with float switches¹⁴, then the following connection sequence applies:

Input Measuring method	SW HW	SW1	SW2 NVS1	SW3 NVS2
Level sensor	High water float switch (when required)	-	Level sensor (HSK15)	Level sensor (HSK25)
Impact pressure		-	-	-
1 x float switch		Float switch1	-	-
2 x float switch		Float switch 1	float switch 2	-
3 x float switch (only HSK25)		Float switch 1	float switch 2	Float switch 3

¹⁴ Due to the low currents, it is recommended to use float switches that feature gold flashed contacts.

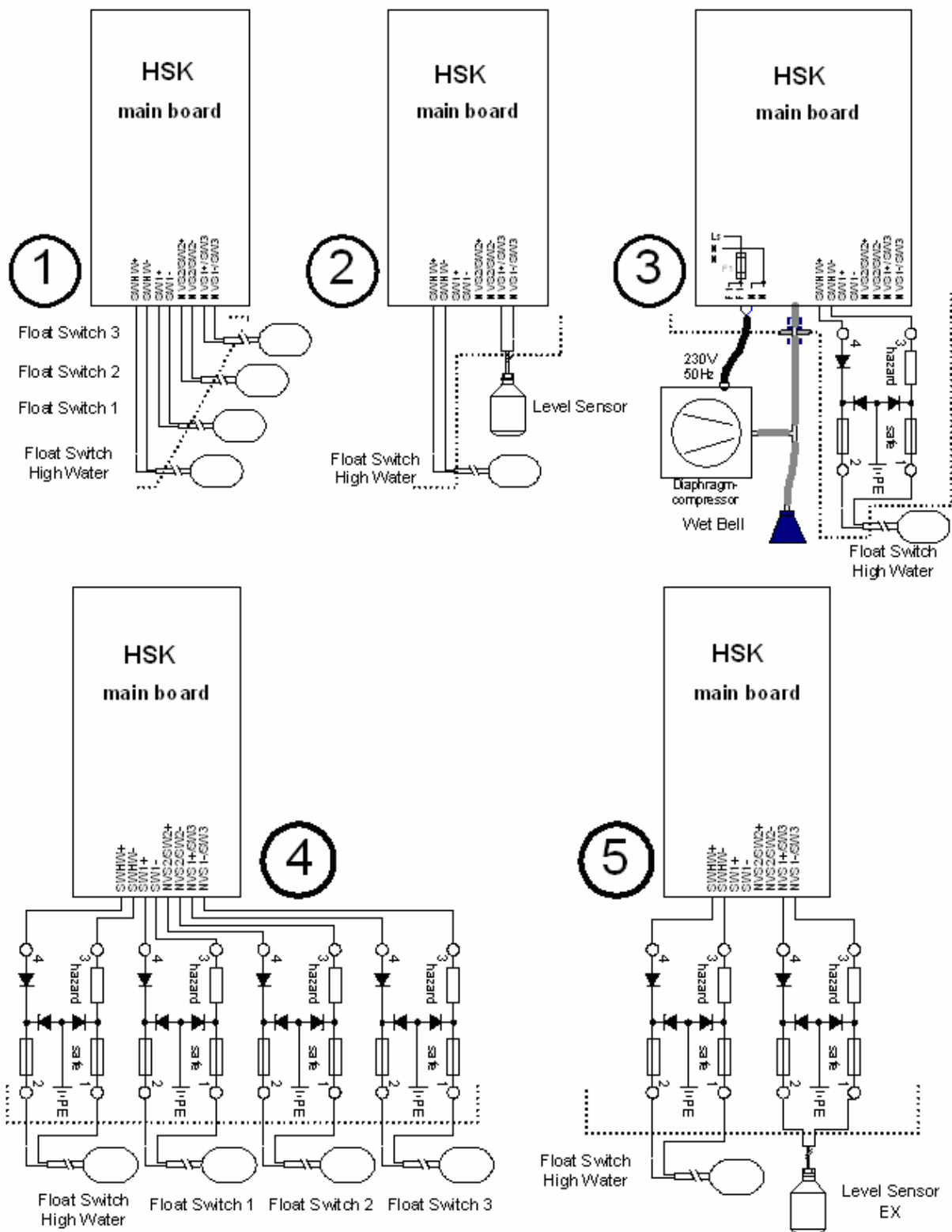

Wiring diagram examples

The connection diagrams above explain the principal connecting possibilities using various level measuring methods:

1. Float switch
2. Level sensor with high water float switch
3. Bubbler system with high water float switch (float switch – connection to an electrical (Zener) barrier)
4. Float switch connected to an electrical (Zener) barrier
5. Level sensor with high water float switch connected to an electrical (Zener) barrier

11.5 Level measurement according to the impact pressure method

If the impact pressure method is used as the measuring method, then the plastic tube (pneumatic tube $\varnothing 8$ mm) is attached to the quick connect found on the bottom side of the control unit's housing.

If an air bubbler system is used, then it must be observed that an excess pressure is generated in the measuring system. Due to this excess pressure, the indicated level is therefore too high. This has to be taken into account during adjustment of the switching level. The pressure being generated by the pump at the 0cm level can be used, however, to monitor the function of the small air compressor.

Using the additional run-on time, the system is adjusted in such way that the wet bell is outside the water. The pressure (or the measured level) respectively can not be zero. Otherwise the pump or the small air compressor is faulty. Monitoring of the minimum pressure checks if the pressure falls below the adjusted minimal value.

Remark: Switch off the bubbler system during zero adjustment!

11.6 Voltage surge protection

The mounting of a suitable voltage surge protection is recommended particularly in case of installation in an open area, in case of connection to supply facilities with open wires or in other environments where voltage surges are to be expected. Additionally, voltage surge protection can also be required for the float switch / level probe supply cables. In intrinsically safe circuits only suitable EX – protective elements are allowed to be used.

12 Appendix

12.1 Example for fault codes in fault memory

The function of the fault memory can best be explained by the following example.

Following fault situation has occurred:

10.12.99 13:07 P1 T1
10.12.99 16:10 P1T1, P1MS, HW

Then the fault memory shows:

1.10: P1 T1 10.12.99 16:10

after ▼-key

1.12: P1MS 10.12.99 16:10

after ▼-key

1.10: P1MS 10.12.99 16:10

after ▼-key

1.1: HW 10.12.99 16:10

after ▲-key again

1.10: P1MST1 10.12.99 13:07

and so forth

The fault occurrences can be browsed backwards by means of the ▲-key or forwards by means of the ▼-key.

The first number in the fault memory shows the number of the fault occurrence, the second number after the point – the fault number (1 ... 32). After the colon, the fault short form text is displayed. The date and time of the fault follow in the second line. It is to be observed that several fault occurrences with the same date/ clock time are possible, if the faults have occurred within the same minute.

12.2 General technical data

Operating voltage	3 x 230V/400V 50 Hz +/- 10%
Power consumption of the control (without load section)	max. 29VA; typically 10VA
Control voltage fuse	Fine fuse 5 x 20 mm 3,15AT (EN 60127-2/III)
Terminals of main electric circuit	Screw terminals 4mm ²
Terminal for equipotential compensation	Screw terminal 6/10mm ²
Terminals for control circuit	Screw terminals max. 2,5mm ²
Motor protection (rated current ranges depending on the type)	Thermal over-current and magnetic short circuit trip or thermal overload relay
Fault current protection (option)	4 pole RCD, rated fault current 30mA
Required back-up fuse	maximum 3 x 25A G for control with direct start other depending on pump switching capacity
Level sensor output	4...20 mA (two wire)
Supply voltage of level sensor	Typically 24V DC
Measuring accuracy input of level sensor	± 1% of end value ± 1cm WC (water column)
Measuring range input of level sensor	adjustable between 0...100cm WC (water column) and 0...1000cm
Measuring accuracy Impact pressure	Typically ±1,5% of end value ± 2cm
Measuring range Impact pressure	0 ...200 cm WC (water column)
Resolution of level measurement indication	1cm
Short-circuit current of float switch 1 input, HW (flood)	< 1mA
Switching voltage of float switch 1, HW (flood) input	13.6 V DC
Short-circuit current of float switch 2,3 input	< 25mA
Switching voltage of float switch 2 ,3 input	24 V DC
Short-circuit current thermal contact input	< 10mA
Switching voltage of thermal contact input	230VAC
Max. switching voltage potential-free alarm relay	Max. 230V AC / 24V DC
Switching current potential-free alarm relay	5 A max.(AC1)
Measuring accuracy hour meter	< 0.06% of actual value
Working accuracy of real-time clock	±20ppm – 0.04ppm/°C
Required external protection of potential-free alarm relay	Max. 5A G

Operation temperature range	0 ... 50°C
Storage temperature range	-20 ... 70°C
Air humidity	0 ... 90% RH (non condensing)
Inputs phase loss / phase sequence monitoring	3 x 230/400V +/-10% 50Hz
Switching threshold for phase loss recognition	< 40V at 50Hz
Rechargeable battery	Lead-gel rechargeable battery 12V, 1.2Ah
Charging current of battery	Max: 100 mA
Final charging voltage of accumulator	13.8V
Dimensions of housing (l x b x h) (without main switch cable glands)	200/300/400 x 200 x 140 mm
Weight	approx. 3 kg
Degree of protection	IP54 (with closed cover)
Cable glands (Maximum amount): Pump(s) Mains Float switch, alarm Level sensor, alarm, analogue output equipotential compensation cable	2 x M25 (10...18mm) 1 x M25 (8...14mm) 5 (6) x M16 (4...8mm) 1 x M12 (3...6mm)
Pressure connection	tube Ø8mm(outer) Ø6mm(inner)

12.3 Wiring and connecting diagrams

Wiring and connecting diagrams depend on the existing features of the control and are not a part of this manual. They are enclosed separately. The layout of the wiring terminals X2 of the control board shows the following picture (HSK25 above; HSK15 below). On the HSK25, terminals 4-20mA+/+ DI1, DI2 are available only as an option. F1 = fuse (protection) of the control.

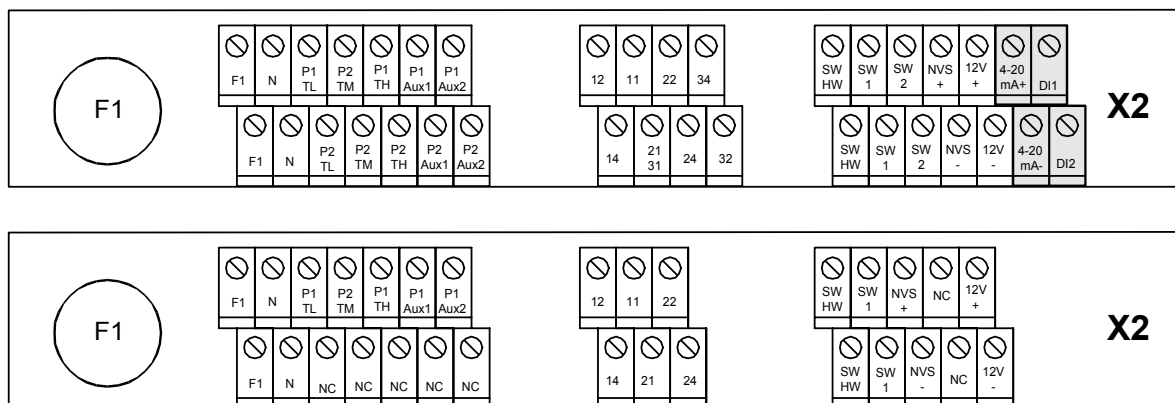

Remarks: Please observe the different terminal connections for the level sensor inputs regarding HSK15 and HSK25.

12.4 Mounting

The control has been foreseen for wall mounting. For mounting purposes, 4 mounting holes for screws with a max. diameter of $\varnothing 6\text{mm}$ must be available. For installing, please open the cover and screw the control to the wall or to the mounting plate tightly with the four screws

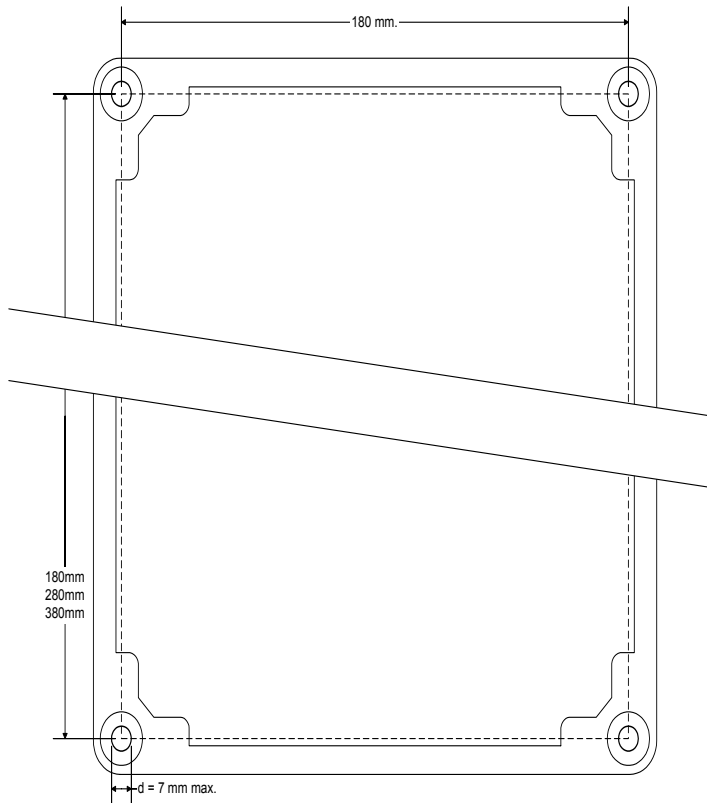

(Dimension of the mounting holes for the control units up to 200 x 400mm, see diagram on the left). After installation, carry out the required electrical wiring. Close the cover and screw tight.

Attention: In order to comply to the Degree of Protection IP54, the enclosure cover must be closed tight! Not used cable gland holes have to be replaced by a screw cap.