

Installation and Operation Instruction Manual

**Submersible mixer
with direct drive**

**HRS 18
HRS 28**

TABLE OF CONTENTS

	Page
1. Safety regulations	4
2. Area of application	5
3. Type designation	6
3.1 Machine plate	6
3.2 Technical specifications.....	7
3.2.1 Overall details	7
3.2.2 Motor.....	7
3.2.3 Seal casing	7
3.2.4 Propeller	7
4. Power configurations.....	8
5. Transport.....	9
6. Receipt of goods / Storage	9
7. Installation	10
8. Commissioning.....	11
8.1 Checking the oil level	11
8.2 Operating voltage / Direction of rotation	11
8.3 Electrical connections	11
8.3.1 Motor protection systems	12
8.3.2 Gearbox protection system.....	13
8.3.3 Overload relays.....	14
8.3.4 Switching mode	14
8.3.5 Connection diagram and circuit plan	14
9. Servicing / Lubrication	15
9.1 Servicing chart	15

10. Corrosion protection	16
10.1 Protection from surface corrosion	16
10.2 Protection from electrochemical corrosion.....	16
11. Troubleshooting	17
11.1 Indications of problems.....	17
11.2 Possible reasons for the problems	17
12. Disposal	18
13. Warranty / Liability	18
14. List of Spare parts	20
Appendix	21

1. Safety regulations

The following safety instructions should be followed when transporting, storing, handling and operating the mixer.

The mixer may not be used:

- ### before you have carefully read the operating instructions
- ### when servicing and repairs are being carried out
- ### when the mixer basin is being repaired or serviced
- ### when the mixer position is being changed
- ### when the mixer is damaged or there is a suspicion of possible damage if it is used.
- ### when less than half of the diameter the mixer propeller is covered by the medium

The design of the mixer may not be altered without the permission of the manufacturer. If there is any change in the use to which the mixer is put or in the properties of the liquid to be agitated, please contact the manufacturer of the mixer.



Before assembling the components supplied, installing or commissioning the mixer, please read the mixer operating instructions carefully.

All regulations that are effective both nationally and locally for the promotion of safety and the prevention of accidents must be observed.

The mixer may only be installed, connected, serviced, or repaired by trained specialists.

Beware of rotating machine parts.

Please take note of the following safety recommendations. They are marked as follows:

	Electrical hazard , e.g. when working when the machine is live
	Mechanical hazard , e.g. when working on lifting gear, rotating components, etc.
	Important instructions for safe and trouble-free operation, e.g. pre-adjustments prior to commissioning

2. Area of application

When fitted with the standard mixer blades, mixers manufactured by HOMA are ideally suited to applications involving the mixing, i.e. the homogenizing and suspending of liquids of low to medium viscosity.

Please contact HOMA for further information on other applications, such as the mixing of viscous media or explosive materials.

In the event of damage, please contact the nearest service center or the manufacturer.



This machine may not be operated under conditions which exceed either the threshold values stated on the factory specification plate or any other instructions contained in the operating regulations or the contractual documentation. All prescribed electrical connection figures as well as all installation and servicing instructions must be adhered to without exception. Any use of the machine which exceeds the conditions contained in the operating manual can result in the failure of the machine.

Non-compliance with this warning can result in personal injury and material damage.

NB !

All descriptions and instructions in these operating regulations are based on the Standard model. These operating regulations do not take into account all details and variations in design and construction nor any possible eventualities or events that may occur during erection, operation or servicing.

These operating regulations do not take any local safety regulations into account. The operator of this installation is responsible for ensuring that such regulations are adhered to and that they are followed by the installation personnel who install the mixer.







The type plate on the casing identifies the type of mixer, the most important operating data and the machine number or serial number respectively. These details must always be given when information is required, when reordering machines or spare parts.

In the event of damage, please contact the nearest service center or the manufacturer.

3.Type designation

3.1 Machine plate

The factory plate on the casing identifies the type of mixer, the most important operating data and the machine number or serial number respectively. These details must always be given when information is required, when ordering machines or spare parts.

 HOMA		Homa Pumpenfabrik GmbH D-53819 N.-Seelscheid			
Motor:					
∇	m	IP58	Nr.	Bj.	
min ⁻¹		Isol.Kl.: F	Hz	kg	
	Motor:	~	P ₁ /P ₂	kW	
U:		I:	Cosφ		
Pumpe:					
H _{max}	m	H _{min}	m	Q _{max}	m ³ /h
					

Typ	:	Mixer type (name of the mixer)
Masch-Nr.	:	Continuous identification number plus the year of manufacture
Typ-Bez.	:	Precise type designation of all mixer components
P _N	:	Nominal rating [kW]
I _N	:	Rated current (current consumption at nominal rating) [A]
U	:	Voltage [V]
f	:	Power supply frequency required [Hz]
n _N	:	Nominal motor-shaft speed [rpm]

In addition to the type plate on the submersible mixer, a second, separate type plate is also supplied. This plate must be affixed in a clearly visible location away from the mixing container (e.g. on the switchgear cabinet).

3.2 Technical specifications

3.2.1 Overall details

Manufacturer:	HOMA
Type of mixer:	Submersible mixer without transmission, horizontal
Type designation:	HRS
Power cable:	8.0 meters (standard length, suitable for basins up to 5 meters depth)
Corrosion protection mixer:	Primed, special corrosion protection optional
Corrosion protection installation:	Stainless steel (AISI 304 L / 316 / 316 L)

3.2.2 Motor

Manufacturer:	HOMA
Protective system:	IP 68 to 20m
Insulation class:	F
Sealing:	2 radial shaft sealing rings
Bearings:	2 RS-roller bearings
Motor casing material:	Cast iron, grade 25 (GG-25)

3.2.3 Seal casing

Manufacturer:	HOMA
Type:	Seal casing incl. shaft bearings; mechanical shaft ring sealing as adaptation to the motors of models type 50
Sealing to medium:	Mechanical shaft ring sealing US 3-A with encapsulated pressure spring
Sealing to motor:	2 radial shaft sealing rings
Seal monitoring:	Leak sensor in the blocking chamber
Shaft bearings:	FAG taper roller bearings (3207B); double rows
Shaft material:	16CrNi4
Seal casing material:	Cast iron, grade 25 (GG-25)

3.2.4 Propeller

Number of blades:	3
Propeller design:	Self cleaning, optimal flow design with endfins
Propeller diameter:	320 / 390 (420 mm for biological zones)
Propeller / hub material:	Stainless steel AISI 304 L / Cast iron NiCrNb 20 2 (Ni-Resist D-2)

4. Power configurations

Type HRS mixers are available in the following power and propeller configurations:

Mixer type:	HRS 18	HRS 28
	1.8 kW	2.8 kW
Motor:		
Motor size	100	100
Mech. nom. rating	1.8 [kW]	2.8 [kW]
Electr. actual power [kW]	2.4	3.6
Nominal speed [rpm]	950	930
Rated current ¹⁾ [A]	5.4	6.8
Rated current ²⁾ [A]	6.0	7.5
Power factor [cos ###]	0.73	0.76
Operating mode	S1, Y	S1, Y
Mains voltage [V]	3 x 400	3 x 400
Permissible motor voltage [V]	230/400	400/690
Mains frequency required [Hz]	50	50
Starting type	Direct start Y	Direct start Y
Gearbox:		
Reduction [-]	none	none
Output speed [rpm]	950	930
Propeller:		
Number of blades [-]	3	3
Diameter [in mm]	320	390
Capacity ¹⁾ [m ³ /h]	786	1153
General data:		
Axial thrust force ¹⁾ [N]	296	429
Output torque ¹⁾ [Nm]	18.1	28.7
Total weight [in kg]	58	59

¹⁾ This figure applies to operation with pure water.

²⁾ Given a medium viscosity greater than that of water, the mixer can be operated up to this figure without any problem.

5. Transport

The mixer may only be lifted using the suspension points provided.

The winch or lifting tackle supplied incl. the chain or cable to raise and lower the mixer in the basin may not be used as a universal form of lifting equipment.



Never hang the submersible mixer by the motor cable! Please refer to **§ 15 Annex O15-3** for weight details and the position of the center of gravity.



For transportation the mixer must be packed carefully to avoid damage to the surface protection. Special attention must be given to avoid bending of the propeller blades.

6. Receipt of goods / Storage

Receipt of goods

The shipment must be inspected for damage immediately on arrival. In case of damage, a damage claim form must be completed in the presence of the haulage operator / driver and sent to the country service representative or manufacturer without delay.

Storage

If the mixer has to be stored, it is essential to select a storage area that is free from oscillations and vibration in order to prevent the roller bearings from being damaged. The machine must also be stored on dry premises in which the ambient temperature is not subject to major fluctuations.

During storage and handling of the mixer special attention must always be given to avoid damage to the corrosion protection.

7. Installation

7.1 General instructions



All stainless steel threads must be greased in advance with a suitable paste. E.g. an ALU-paste may be used. Always ensure that installation and fitting tools (cutoff disks, open-ended wrenches, screwdrivers, files, etc.) are strictly separated for use with stainless steel parts and normal steel parts. If this is not done, microscopic rust particles on these tools can be pressed into the stainless steel parts where they will trigger off a corrosive reaction that can lead to their destruction in time.

Tightening torque [Nm] for screws A2/A4 (Frictional index = 0.2) and Adhesive anchor A4

	Bolt F-Class 70	Bolt F-Class 80	Adhesive anchor A4
M 6	8.8	11.8	----
M 8	21.4	28.7	10
M 10	44	58	20
M 12	74	100	30
M 16	183	245	60
M 20	370	494	120



Allow the composite adhesive to cure fully before subjecting the adhesive anchor to loads. Curing times vary from manufacturer to manufacturer. Please read the information enclosed with the adhesive anchor.

Adhesive anchors are only used for the installation of the column base and upper mounting.

Adhesive anchor: **### Bolt ### + 2 mm = ### of hole to be drilled.**

Galvanic separation

The column base and the upper mounting are installed with adhesive anchors. As the adhesive anchor may have contact with the reinforcement iron in the concrete, the anchor must be insulated from the mounted parts by using POM-Sockets. Differentiation of the mounting is made between a penetration hole and a slotted hole.

Penetration hole:

- Adhesive or bolt anchor
- Part to be mounted
- -----
- POM bush
- Spacer
- Spring washer
- Nut

Slotted hole:

- Adhesive or bolt anchor
- Part to be mounted
- Washer
- POM bush
- Spacer
- Spring washer
- Nut

8. Commissioning

The mixer can only be commissioned when the checks in this chapter have been made and it is made sure, that there are no solid objects in the mixing tank. In addition, the mixer must not run outside the medium (dry), as the motor will heat up and may be damaged. It must be made sure that the mixer is at least so far submerged that half the diameter of the propeller is covered. Further it must be made sure that no person can involuntarily fall into the mixing tank or basin. The foreseen protection (covers, railings, etc.) must have been mounted.

8.1 Checking the oil level

(See page 23)

8.2 Operating voltage / Direction of rotation

- ###** The voltage of the mains power supply must match the voltage stated on the type plate.
- ###** After making the electrical connections (**§ 8.3**), ensure that the mixer blades are rotating in the correct direction. (When viewed from the motor, the blades must rotate clockwise.)
- ###** If the mixer blades rotate in the wrong direction, two of the three conductor phases (L1, L2, L3) coming directly from the mains power supply must be changed over.



The three conductor phases (L1, L2, L3) must not be confused with the neutral conductor (N) or the earth (ground/PE) conductor. Do not transpose any of the conductors that come from the motor (U1, V1, W1, or U2, V2, W2) on the terminal board. If this is done, they will no longer match the Y-###-starting controls.

8.3 Electrical connections



DANGER !

The voltage-carrying and rotating parts of electric machines can cause severe or fatal injuries. Erection, connection, commissioning as well as servicing and repair work may only be carried out by qualified technicians with due regard for

these instructions

all other project documentation relating to the drive, commissioning instructions and electrical schematics

all currently valid national and local regulations relating to safety and accident prevention

As a principle all electrical connections must be carried out by a qualified electrician.
All DIN regulations of the SEV must be observed.

The mixer is supplied complete with connection to mains. The core code numbers are indicated along the corresponding cores (s. connection diagram in § 8.3.4) or as otherwise indicated.

Before connecting the motor, the actual operating voltage must be compared with the voltage data on the motor specification plate and the motor switching. Please refer to **Fig. 8.2**.



Motor switching: please note the following:

When the voltage stated is 230/400 volts, the motor must be connected in star configuration.

When the voltage stated is 400/690 volts, the motor must be connected in delta configuration.

8.3.1 Motor protection systems

The following types of motor protection can be selected in accordance with customers' requirements:

Thermal winding-protection contact known as a Klixon (PTO)

PTC sensor

Description of the operating function of the thermal winding protection contact:

The motor is protected against overheating by an integral protection device. This is a thermal winding protection system covering all three stator windings.

The temperature is monitored by three bi-metallic switches which cause the mixer to be switched off when the maximum temperature in the windings is reached.

After the windings have cooled down to below this temperature, the bi-metallic switches close, and the mixer can be restarted either automatically or manually.

(The insulation of the stator windings will be damaged at a temperature of 160 °C.)

- F6: Thermal winding protection (bi-metallic switch)
- 2 conductors (core code numbers 11 and 12)
 - max. operating voltage of the switch: 250 V
 - max. switching current: 2.5 A at $\cos \text{###} = 1$
 - triggering temperature: 130°C **###** 5°C

Description of the operating function of the PTC sensor (according to DIN 44081):

Winding-temperature monitoring can be guaranteed by 3 PTC sensors according to DIN 44081. When overheating the motor is switched off. Automatic reconnection is not permissible in such cases. This requires a thermistor trigger unit with a reconnection suppressor in the control circuit of the motor contactor.

- v1, v2, v3: 3 PTC thermistors in the motor windings
- 2 cores (core code numbers 31 and 32)
 - max. operating voltage at the terminals: $U_{\max} = 30 \text{ V (DC)}$
 - Resistance between the terminals 31/32:
 - at room temperature $R = 300 - 750 \Omega$
 - at switch off temperature $R \geq 4000 \Omega$



Attention !

For transmission tests at the terminals 31/32 no higher test voltage than 30 V (DC) must be used. Use Ohmmeter for the transmission test.

8.3.2 Gearbox protection system (Propeller bearings and sealing)

The gearbox is tested for the ingress of water by a leak sensor. If moisture enters the gearbox, a measuring current of up to 10 mA will flow through the integral leak sensor (core code numbers 21 and 22). This triggers an alarm signal and/or switches off the motor.

- B2: Leak sensor
- 2 cores (core code numbers 21 and 22)
 - max. operating voltage ca. 8.6 V
 - max. current 1 to 10 mA

Adjusting sensitivity:

1. Turn the adjusting screw on the relay until the warning light comes on.
2. Turn the adjusting screw in the opposite direction until the warning light goes out.
3. Continue to turn the adjusting screw by an additional 60° (same direction as under 2.)

The leak sensor is incorporated in all mixers as standard equipment. We recommend that this is connected and evaluated with an appropriate relay (**s. Fig. 8.3**).

NB ! This relay is not supplied as standard equipment. If the leak sensor is to be connected, only relays of the type ETA 20/A from HOMA is to be used.

Monitoring leakage in the gearbox

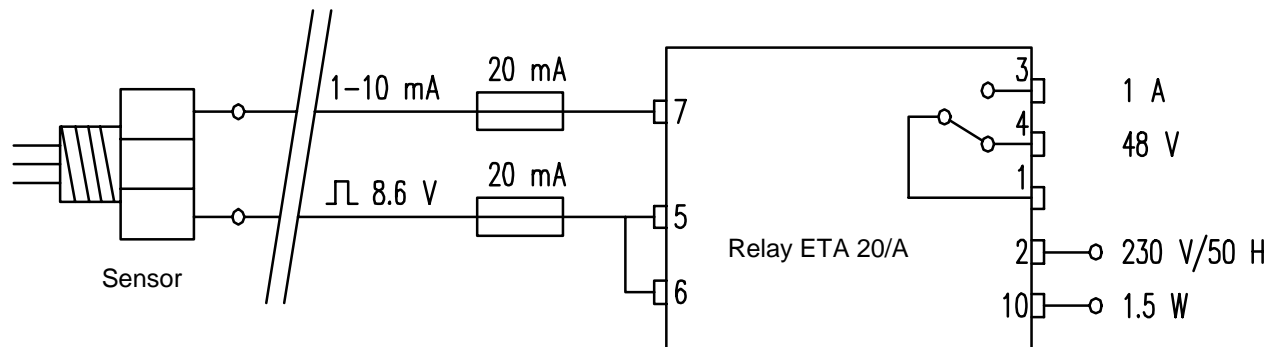

(Fig. 8.3)



Attention !

Do not test the leak sensor with an Ohmmeter or other measuring instruments. The leak sensor is an electronic component (operational amplifier).

If damaged, the mixer must be repaired by the manufacturer.

8.3.3 Overload relays

The motor is to be protected against overload through a thermal delay relay according to DIN. This is to be adjusted to the rated current indicated on the machine plate.

In case of star-delta starting the adjustable value is to be $I_N \times 0.58$. In both motor cables (U1, V1, W1 and U2, V2, W2) electro-thermal all-pole triggers are to be incorporated.

8.3.4 Switching mode

Star-delta starting is required for motors with an output of 4.0 kW and more. Below this power output (0.75 - 2.8 kW), direct starting is provided for continuous operation.

8.3.5 Connection Diagram and Circuit Plan

(see Page 25)

9. Servicing / Lubrication

(see page 24)



When carrying out all general servicing, inspection and repair work, the mixer must be disconnected from all power circuits, i.e. motor power circuit, leakage circuit and windings protection circuit. It must also be secured or blocked against unintentional reconnection. It is up to the electrical contractor responsible for installation to decide if it is necessary to combine this disconnection switch with an emergency STOP switch.

9.1 Servicing chart

	Service operation	Lubrication	Inspection
Electric motor	Maintenance free.	The roller bearings are sealed for life. (To be replaced only if they develop noise.)	The motors are filled with dielectric oil. Neither servicing, oil level check nor oil change is required.
Power cable			The power cable must be checked once a year for surface damage, strain and kinks, etc. Immediate replacement by the manufacturer in case of damage.
Sealing casing		Oil change every 8000 hours. Min. every 2 years (see page 24)	
Propeller			Check the propeller blades periodically for wear and tear.

10. Corrosion protection

10.1 Protection from surface corrosion

The HRS mixers and the installation units are protected from corrosion as follows:

	Corrosion protection
Column (Tube) Motor bracket (Console) Upper fixation	Made from stainless steel (AISI 304 L) (DIN 1.4435 or 1.4571 supplied on request)
Column base bearing	Made from stainless steel (AISI 316 L)
Service Crane incl. socket	Galvanized steel
Motor / Sealing casing	Cast iron, grade 25 (GG-25), primed High-grade multiple-layer corrosion protection optional
Propeller blades / Hub	Stainless steel (AISI 304 L) / Ni-Resist D-2
Pull chain and Traction rope	Stainless steel (AISI 316)

10.2 Protection from electrochemical corrosion

Two different metals or alloys of different metals cause electrochemical corrosion if they are connected by an electrolyte. In order to alleviate this effect, components such as the:

Motor bracket - column

Column - column base and top mounting

Top mounting and column base - steel reinforcing in concrete or steel bridge should be galvanically separated from each other by POM bushes.

To give the mixer additional protection, we recommend

- 1. the galvanic separation of the earthing function or**
- 2. the galvanic separation of the mains supply**

The earth conductor must be split in such a way as to ensure that no direct current can flow over it. However, it must still function as a protective conductor. This can be achieved with a limiting unit (polarization cell or anti-parallel diode) or an isolation transformer.

(see page)

11. Troubleshooting

11.1 Indications of problems

Problem	Reasons for the problem (s. § 11.2)
Mixer does not start up	1, 2, 3, 4, 5, 6, 7, 8, 9
Mixer starts but switches off immediately	5, 7, 8, 9
No or inadequate circulation produced despite the motor running	10, 11, 12, 13,
Mixer runs unevenly and noisily	12, 13, 14, 15
Heavy current and power consumption	1, 2, 3, 4, 5, 11, 12, 14,

11.2 Possible reasons for the problems

1. Operating voltage is not available or is inadequate
 - Check the electrical installation
 - Call in the electrician
2. Motor cable is faulty (*)
3. Faulty control system (*)
4. Mixer blades cannot rotate (**)
 - Clean the blades and manually check rotation
5. The stator windings are faulty (*)
6. Faulty automatic system equipment (*)
7. Different phase voltages (*)
8. Motor contactor is set too low or is faulty
 - Check the thermal relay; adjust the motor contactor to rated current (**§ 4**)
9. Leakage monitor is switching the mixer off (*)

Leakage monitoring only when the mixer is submerged
10. Mixer blades rotate in the wrong direction
 - Transpose two phases of the mains supply
11. Mixer runs on two phases
 - Replace faulty fuses
 - Check the supply connections
12. Internal parts are excessively worn (*)
13. Propeller blades are dirty or damaged (**)
 - Clean the blades and inspect for any wear (*)
14. Faulty motor or gearbox roller bearings (*)
15. Oscillations caused by the installation (resonance) (*)

(*) Manufacturer must be contacted; (**) The mixer must be switched off and secured against further use

12. Disposal

	Method of disposal
Motor and Seal casing	Scrap-metal collection
Used oil	Used oil collection
Propeller	Scrap-stainless steel collection
Column (tube)	Scrap-stainless steel collection
Motor bracket (console)	Scrap-stainless steel collection (POM bearings in refuse collection)
Column base bearing	Scrap-metal collection (POM bearings in refuse collection)
Top mounting	Scrap-metal collection (POM bearings and bushings in refuse collection)
Crane incl. socket	Scrap-metal collection (PU tube in refuse collection)
Power cable	Refuse incinerator (contains chlorine)

13. Warranty / Liability

Warranty

All parts that are subject to natural wear and tear are not covered by the warranty. This applies to bearings, seals, gears and other components subject to dynamic loads.

Damage caused by non-compliance with the operating regulations is also excluded from the warranty.

Liability

The manufacturer cannot accept any liability for the mixer if interventions or repair work are carried out during the warranty period by any third party (or parties) without the manufacturer's prior consent.



**All inquiries or orders for spare parts must include the number of the machine !
If the specification plate contains a serial number (that only gives details of its electrical layout), the data stamped into the motor casing must also be supplied.**



Danger !
This machine may not be operated under conditions which exceed either the threshold values stated on the factory specification plate or any other instructions contained in the operating regulations or the contractual documentation. All prescribed electrical connection figures as well as all installation and servicing instructions must be adhered to without exception. Any use of the machine which exceeds the conditions contained in the operating manual can result in the failure of the machine.
Non-compliance with this warning can result in personal injury and material damage.

NB !

In the event of damage, please contact the nearest service center or the manufacturer.

The manufacturer cannot be held liable for damage to the machine that can be attributed to mistakes made during installation, operating errors or non-compliance with the regulations contained in the operating instructions. No liability whatsoever for any indirect consequential damage or for natural wear and tear (seals, etc.) can be accepted by the manufacturer nor can any warranty obligations be derived from such events. If the machine is to be used under extreme conditions (high abrasion, high viscosity, etc.), advice must be obtained from the manufacturer in advance in order to establish whether the materials employed in the construction of the machine are suitable.

14. List of Spare parts

Item	No.	Designation	Material
1	1	Hex-head screw, M8x30	V2-A
2	1	Nabendeckel	PE gray
3	1	Hex-head nut, M24x1.5; DIN 934	V2-A
4	1	Spring ring with flat ends for M24, DIN 127B	V2-A
5	1	Fit spring 8x7x25; Form A	DIN 1.4301
6	1	Hub HRS	GGG-NiCrNb 20 2
7	1	Stick shaft HRS	16CrNi4
8	1	Seal ring US3A Ø 32	V4-A / Hard carbon / Al-Oxide
9	1	Pin suspension Ø 3x20	Ck 45 N
10	2	Closing screws Rp ¼ "-10	Brass
11	6	Hex-head screw, M8x30; 8.8	Screw steel 8.8
12	2	O-ring Ø2.62x158.42	NBR
13	8	Hex-head screw, M6x20; 8.8	Screw steel 8.8
14	8	Spring ring for M6; DIN 127B	Spring steel
15	1	O-ring 3450 Ø2.62x290	NBR
16	1	Rubber packing for motor type 50	
17	1	Hex-head screw, M6x10; 8.8	Screw steel 8.8
18	1	Washer for M6	Steel
19	1	Washer for M12	Steel
20	1	Hex-head screw, M12x20	Screw steel 8.8
21	1	Cover switch-box for motor type 50	Cast iron, grade 25
22	1	Rubber cable sealing, front	Rubber Shore 60
23	1	O-ring Ø1.78x38	NBR
24	1	Lock washer for cable entry motor type 50	Brass
25	1	Rubber cable sealing, front	Rubber Shore 60
26	1	Cable protection tube	Galvanized steel
27	1	Cover for cable entry motor type 50	Cast iron, grade 25
28	1	Power cable Ø 18; 11-core (standard 8 m)	Polychloropren
29	1	Bearing extraction cover motor type 50	Cast iron, grade 25
30	4	Washer for M8	Steel
31	4	Hex-head screw, M8x25	Screw steel 8.8
32	1	O-ring Ø 2250	NBR
33	1	Spring washer for bearing 6206	Spring steel
34	1	Ball bearing 6206 Ø 62 / 30-16	SKF-Bearing steel
35	1	Stator 6-poles motor type 50	
36	1	Rotor motor type 50	
37	1	Motor casing type 50	Cast iron, grade 25
38	1	Leak sensor for motor type 50 Type P	
39	1	Bearing front plate motor type 50	Cast iron, grade 25
40	3	Hex-head screw, M6x20; 8.8	Screw steel 8.8
41	1	Seal casing for HRS	Cast iron, grade 25
42	1	Safety ring DIN 472 for drill Ø 72	Spring steel
43	1	Safety ring DIN 471 for shaft Ø 35	Spring steel
44	1	Inclined ball bearing, 2 rows 3207B Ø 72/35-27	SKF-Bearing steel
45	1	O-ring Ø 1.78x22	NBR
46	1	Radial shaft sealing ring Ø 32 / 62-8	NBR
47	1	Ball bearing 6206 Ø 72 / 35-17	SKF-Bearing steel
48	1	Radial shaft sealing ring Ø 72 / 40-8	NBR

Spare Part Drawing:

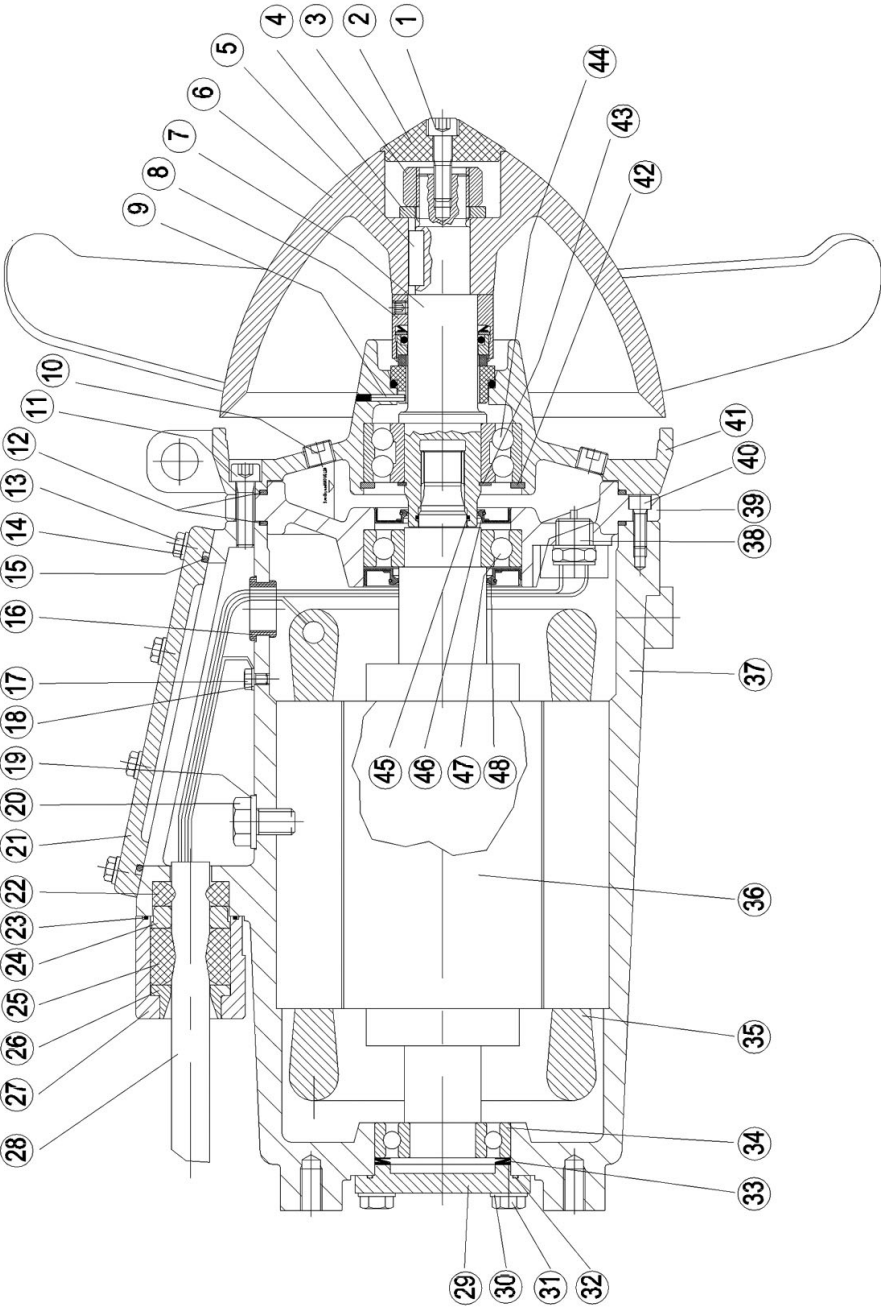

Installation example:

Montagevarianten Pos. 4

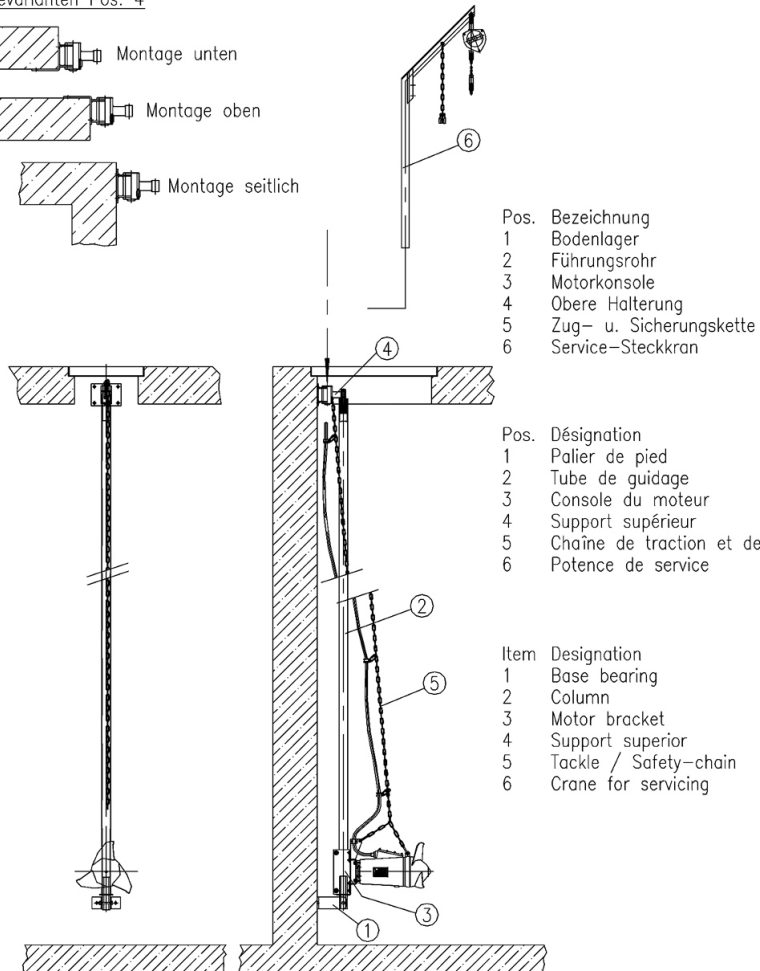
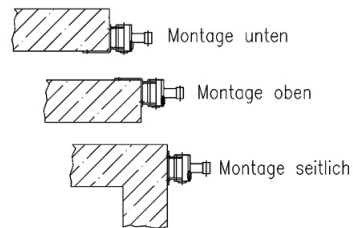

- | Pos. | Bezeichnung |
|------|-------------------------|
| 1 | Bodenlager |
| 2 | Führungsrohr |
| 3 | Motorkonsole |
| 4 | Obere Halterung |
| 5 | Zug- u. Sicherungskette |
| 6 | Service-Steckkran |

- | Pos. | Désignation |
|------|-----------------------------------|
| 1 | Palier de pied |
| 2 | Tube de guidage |
| 3 | Console du moteur |
| 4 | Support supérieur |
| 5 | Chaîne de traction et de sécurité |
| 6 | Potence de service |

- | Item | Designation |
|------|-----------------------|
| 1 | Base bearing |
| 2 | Column |
| 3 | Motor bracket |
| 4 | Support superior |
| 5 | Tackle / Safety-chain |
| 6 | Crane for servicing |

Schwenkbereich Pos. 1

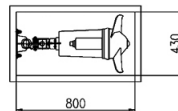
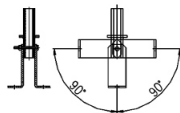

Dimensions:

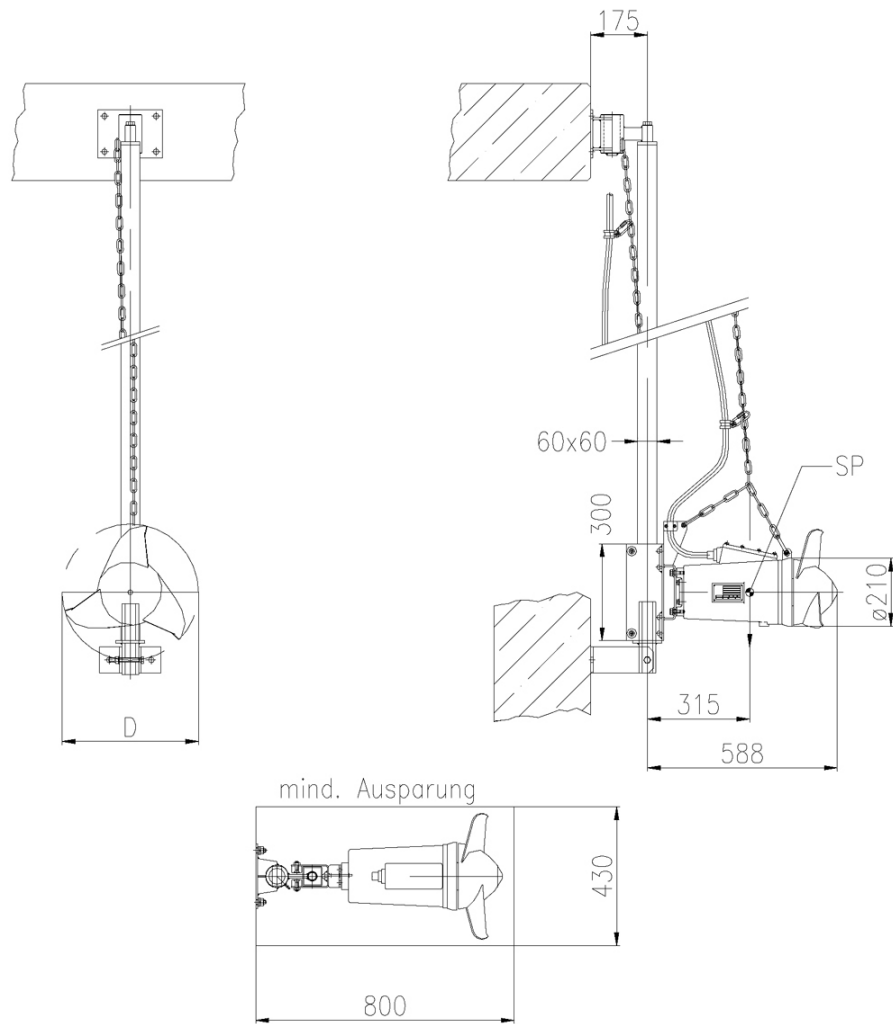

Typ	Nennleistung	Nennstrom	Drehzahl	Fördermenge	Propeller- \varnothing	Gewicht *(ohne Konsole)
	[kW]	[A]	[min ⁻¹]	[m ³ /h]	D [mm]	[kg]
HRS 18	1.8	5.4	950	786	320	*58 / 61
HRS 28	2.8	6.8	930	1153	390	*59 / 62

Service Chart:

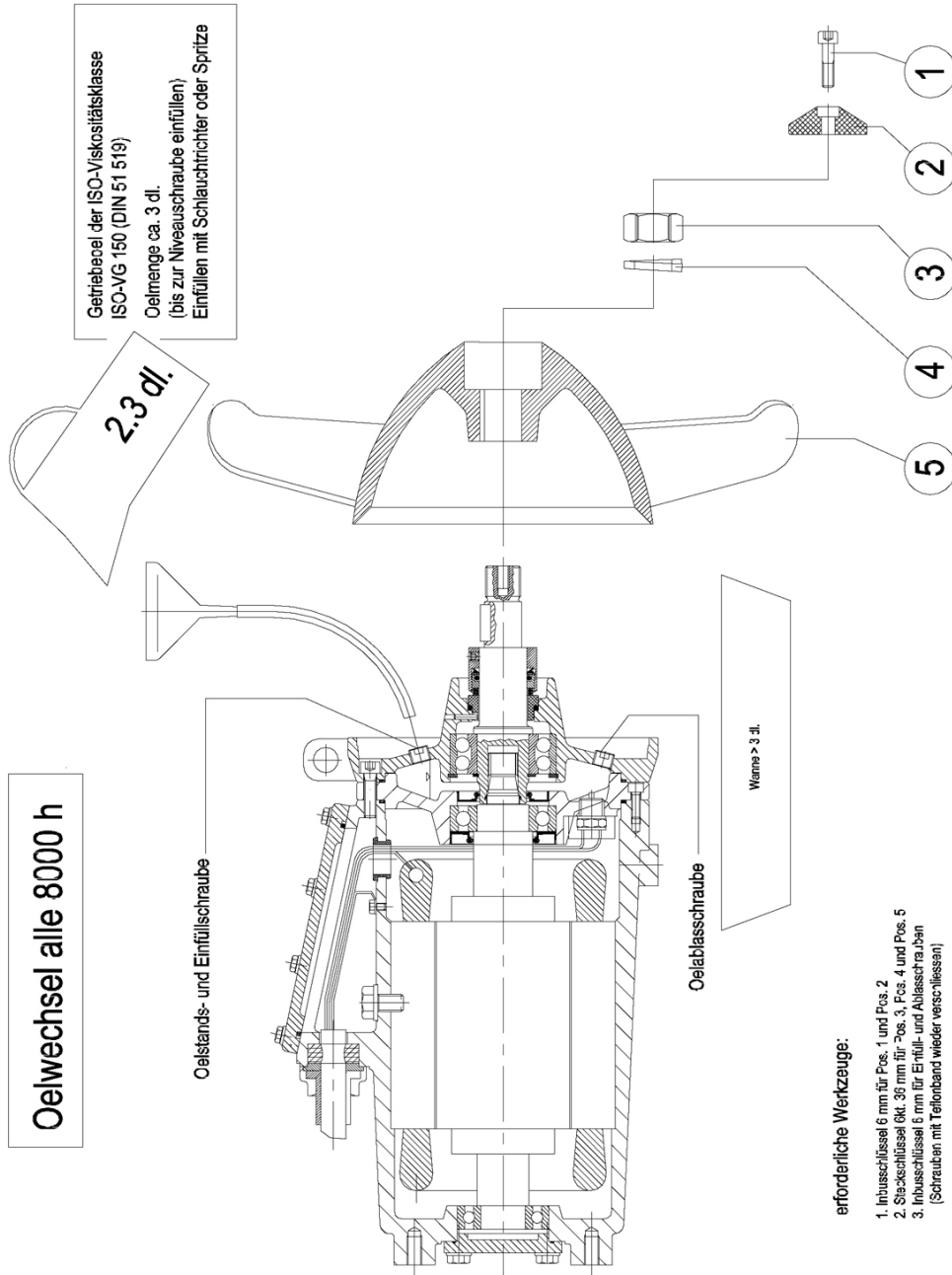

erforderliche Werkzeuge:

1. Inbusschlüssel 6 mm für Pos. 1 und Pos. 2
2. Steckschlüssel 35 mm für Pos. 3, Pos. 4 und Pos. 5
3. Inbusschlüssel 6 mm für Einfüll- und Ablassschrauben
(Schrauben mit Teflonband wieder verschließen)

Wichtig! Propellerblätter nicht beschädigen beim Lösen und Anziehen von Pos. 3

Electrical connection diagram and circuit plan (3 x Klixon)

Elektrischer Anschluss

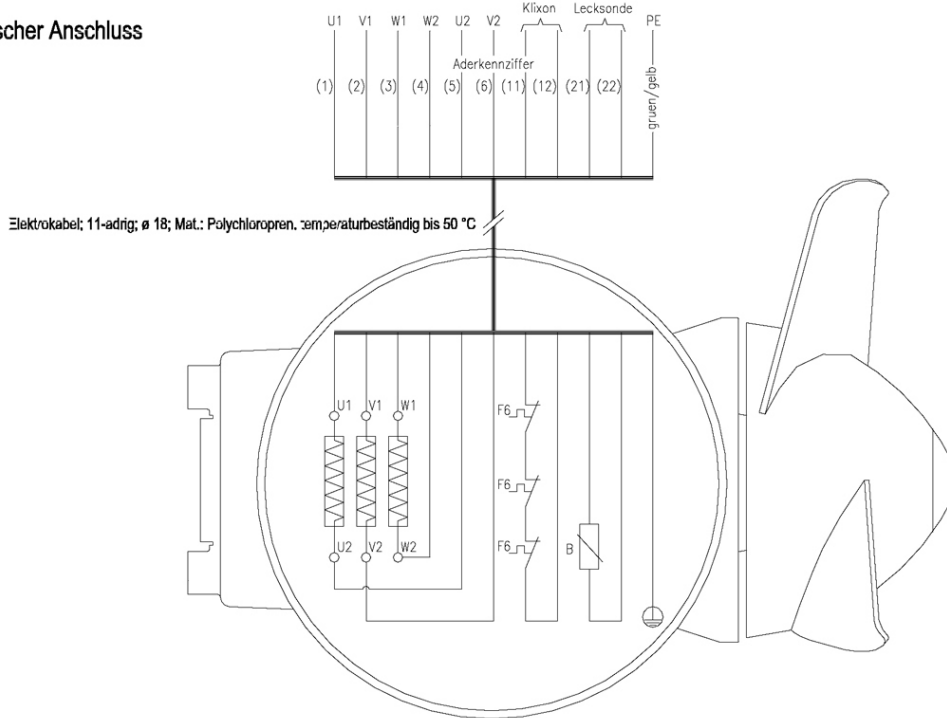

Elektrokabel; 11-adrig; ø 18; Mat.: Polychloropren, temperaturbeständig bis 50 °C

Leiterbezeichnung:	Vorbunden mit	Leiterschnitt:	Eqz. DIN 1304:
1, 2, 3, 4, 5, 6	Wicklungsenden der 3 Statorwicklungen	1.5 mm ²	U1, V1, W1, U2, V2, W2
11, 12	Klixon (Temperaturwächler, Birneialschalter)	1.5 mm ²	F6
21, 22	Lecksonde im Sperrraum	1.5 mm ²	B2

Blockschaltbild (Schaltungsempfehlung)

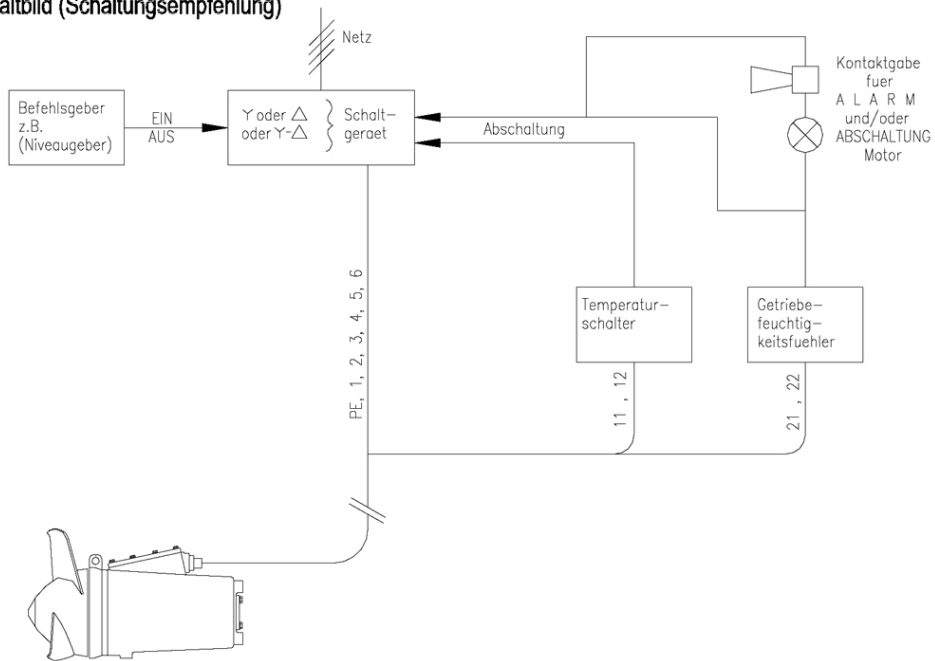

Electrical connection diagram and circuit plan (3 x PTC)

Elektrischer Anschluss

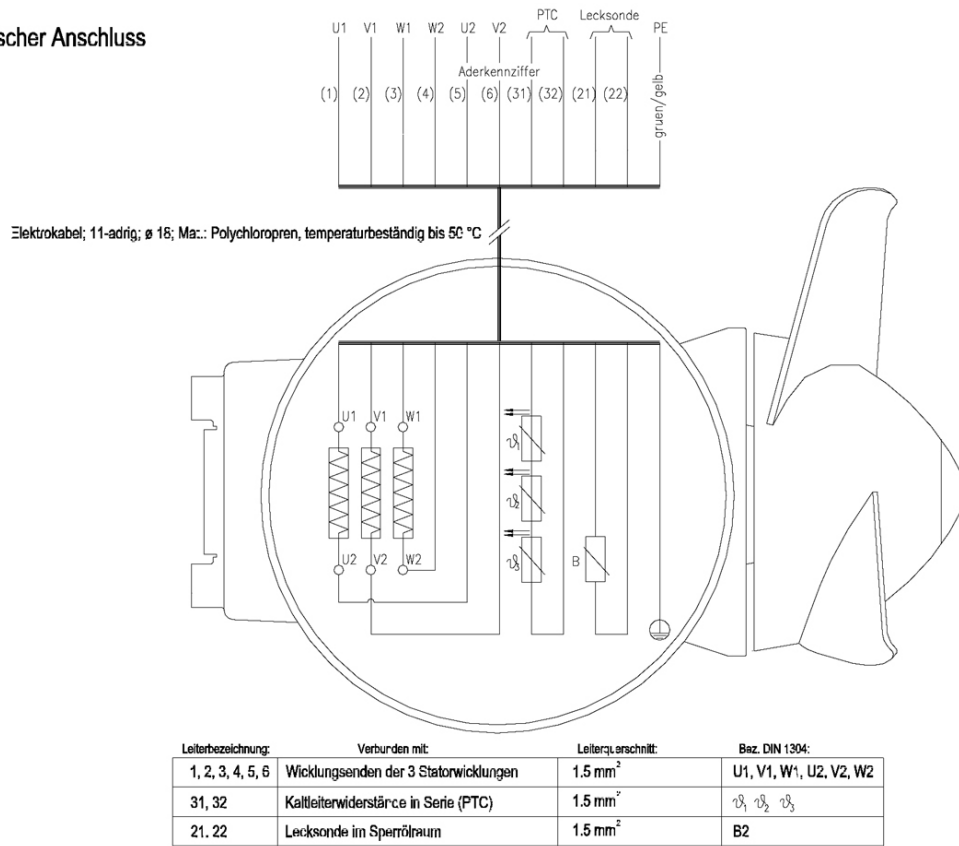

Blockschaltbild (Schaltungsempfehlung)

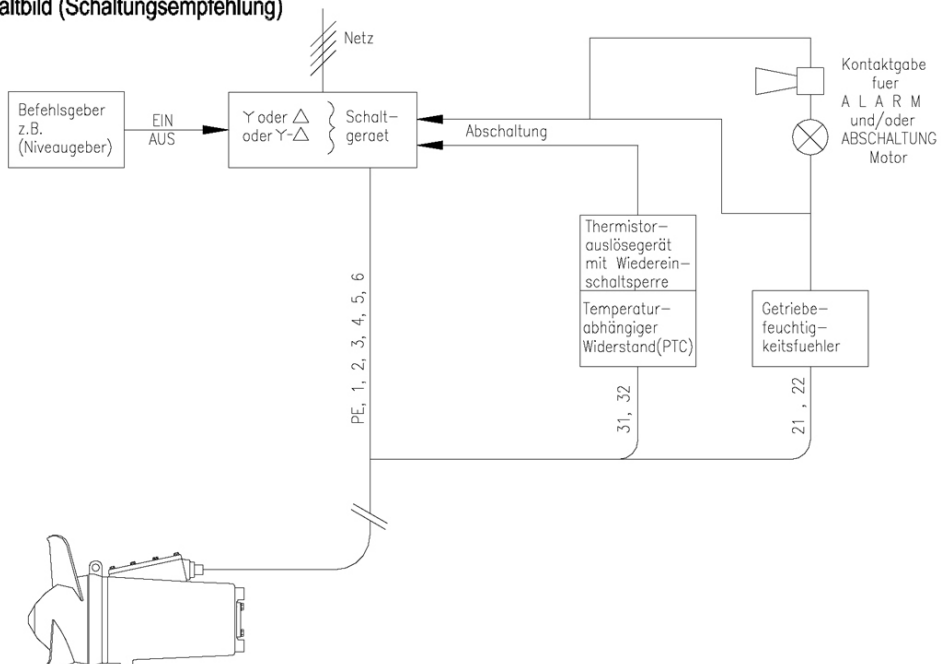

Protection from electrochemical corrosion:

