

**HITACHI**

# PC-RLH9-11

## WIRELESS RECEIVER KIT

INSTALLATION AND OPERATION MANUAL  
MANUAL DE INSTALACIÓN Y FUNCIONAMIENTO  
INSTALLATIONS- UND BETRIEBSHANDBUCH  
MANUEL D'INSTALLATION ET DE  
FUNCTIONNEMENT  
MANUALE D'INSTALLAZIONE E D'USO

MANUAL DE INSTALAÇÃO E DE  
FUNCIONAMENTO  
BRUGER- OG MONTERINGSVEJLEDNING  
INSTALLATIE- EN BEDIENINGSHANDLEIDING  
HANDBOK FÖR INSTALLATION OCH ANVÄNDING  
ΕΓΧΕΙΡΙΔΙΟ ΕΓΚΑΤΑΣΤΑΣΗΣ ΚΑΙ ΛΕΙΤΟΥΡΓΙΑΣ



Do not perform installation work, without referring to our installation manual.  
No realice la instalación de este equipo, sin antes consultar este manual de instalación.  
Bei der Installation unbedingt die Hinweise in der Installationsanleitung beachten.  
Consulter notre manuel avant de réaliser une quelconque installation.  
Realizzare l'installazione, seguendo quanto indicato in questo manuale.  
Nao inicie os trabalhos de montagem, sem consultar o nosso manual de montagem.  
Udfør ikke installationsarbejder uden først at konsultere vores vejledning.  
Voer geen enkele handeling uit om de apparatuur alvorens deze handleiding te hebben doorgelezen.  
Utför inte några installationsarbeten utan att först läsa var installationsmanual  
Μην ήσετε στην εγκατάσταση, χωρίς πριν να έχετε συμβουλευθεί αυτο το εγχειρίδιο εγκατάστασης

ENGLISH

ESPAÑOL

DEUTCH

FRANÇAIS

ITALIANO

PORTUGUES

DANSK

NEDERLANDS

SVENSKA

ΕΛΛΗΝΙΚΑ





**DANGER** – Immediate hazard which WILL result in severe injury or death.  
**PELIGRO** – Riesgos inmediatos que PRODUCIRÁN lesiones personales graves e incluso la muerte.  
**GEFAHR** – Unmittelbare Gefahrenquellen, die zu schweren Verletzungen oder zum Tod führen.  
**DANGER** – Dangers instantanés de blessures corporelles sévères ou de mort.  
**PERICOLO** – Pericolo immediato che PRODURRÀ ferite gravi o la morte.  
**PERIGO** – Problemas imediatos que IRÃO resultar em graves ferimentos pessoais ou morte.  
**FARE** – Overhængende fare, som VIL resultere i alvorlig personskade eller dødsfald.  
**GEVAAR** – Onmiddellijke risico's die ernstige persoonlijk verwondingen of de dood ten gevolge kunnen hebben.  
**FARA** – Omedelbar risk som medför svår personskada eller död.  
**KINAYNO** – Άμεσος κίνδυνος που ΘΑ έχει ως αποτέλεσμα σοβαρές σωματικές βλάβες ή θάνατο.



**WARNING** – Hazards or unsafe practices which COULD result in severe personal injuries or death.  
**AVISO** – Riesgos o prácticas poco seguras que PODRÍAN producir lesiones personales e incluso la muerte.  
**WARNUNG** – Gefährliche oder unsichere Anwendung, die zu schweren Körperverletzungen oder zum Tod führen kann.  
**ATTENTION** – Utilisation dangereuse ou sans garantie de sécurité qui PEUT provoquer de sévères blessures personnelles ou la mort.  
**AVVISO** – Pericoli o azioni pericolose che POTREBBERO avere come esito lesioni fisiche gravi o il decesso.  
**AVISO** – Riesgos o prácticas poco seguras que PUEDEN producir lesiones personales e incluso la muerte  
**ADVARSEL** – Farer eller farlig brug, som KAN resultere i alvorlig personskade eller dødsfald.  
**WAARSCHUWING** – Gevaren of onveilige praktijken die ernstig persoonlijk letsel of de dood tot gevolg KUNNEN hebben.  
**VARNING** – Risker eller osäkra tillvägagångssätt som KAN leda till svåra personskador eller dödsfall.  
**ΠΡΟΕΙΔΟΠΟΙΗΣΗ** – Κίνδυνοι ή επικίνδυνες πρακτικές, οι οποίες ΜΠΟΡΕΙ να έχουν ως αποτέλεσμα σοβαρές σωματικές βλάβες ή θάνατο.



**CAUTION** – Hazards or unsafe practices which COULD result in minor personal injury or product or property damage.  
**PRECAUCIÓN** – Riesgos o prácticas poco seguras que PODRÍAN provocar lesiones personales de menor importancia o daños en el producto u otros bienes.  
**VORSICHT** – Gefährliche oder unsichere Anwendung, die geringfügigen Personen-, Produkt- oder Sachschaden verursachen kann.  
**PRECAUTION** – Utilisation dangereuse ou sans garantie de sécurité qui PEUT provoquer des blessures mineures ou des dommages au produit ou aux biens.  
**ATTENZIONE** – Pericoli o azioni pericolose che POTREBBERO avere come esito lesioni fisiche minori o danni al prodotto o ad altri beni.  
**CUIDADO** – Perigos e procedimentos perigosos que PODERÃO PROVOCAR danos pessoais ligeiros ou danos em produtos e bens.  
**FORSIGTIG** – Farer eller farlig brug, som KAN resultere i mindre skade på personer, produkt eller ejendom.  
**LET OP** – Gevaren of onveilige praktijken die licht persoonlijk letsel of beschadiging van het product of eigendommen tot gevolg KUNNEN hebben.  
**VARSAMHET** – Risker eller farliga tillvägagångssätt som KAN leda till mindre personskador eller skador på produkten eller på egendom.  
**ΠΡΟΣΟΧΗ** – Κίνδυνοι ή επικίνδυνες πρακτικές, οι οποίες ΜΠΟΡΕΙ να έχουν ως αποτέλεσμα την πρόκληση ελαφρών σωματικών βλαβών ή καταστροφή περιουσίας.

ENGLISH

ESPAÑOL

DEUTSCH

FRANÇAIS

ITALIANO

PORTUGÊS

DANSK

NEDERLANDS

SVENSKA

ΕΛΛΗΝΙΚΑ



## 1 SAFETY SUMMARY



**DANGER:**

DO NOT pour water into the remote control switch (hereafter called "controller"). This product is equipped with electrical parts. If poured, it will cause a serious electrical shock.



**WARNING:**

DO NOT perform installation work and electrical wiring connection by yourself. Contact your distributor or dealer of HITACHI and ask them for installation work and electrical wiring by service person.









**CAUTION:**

DO NOT install the indoor unit, outdoor unit, at such places as:

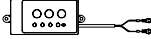
- Where there is oil vapor and the oil is dispersed.
- Where the hot springs are near (in a sulfuric environment).
- Where generation, flowing, staying or leaking of flammable gas is detected
- Where the sea is near ( in the salty, acid or alkaline environment).
- DO NOT install the indoor unit, outdoor unit, within approximately 3 meters from strong electromagnetic wave radiators such as medical equipment.
- In case that there is electric noise at the power source for the indoor unit, provide a noise filter.
- Do not turn ON the power source, unless the preparation for test running is completed.
- Read this manual carefully before installation work for correct performance.

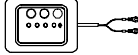
## 2 BEFORE INSTALLATION AND OPERATION

■ The packing contains the following parts. Check the contents and the number of the parts.

Model	Name	Q'ty	Remark
PC-RLH9	Receiver Kit 	1	With Connection cable
	Screw 	2	For Fixing Receiver Kit
	Band 	2	For Fixing Cable
PC-RLH11	Receiver Kit 	1	With Connection cable
	Band 	1	For Fixing Cable
	Screw 	4	For Fixing Receiver Kit
	Screw 	2	For Fixing Clamp
	Clamp 	2	For Fixing Cable

### 3 INSTALLATION OF WIRELESS RECEIVER KIT



**CAUTION:**

Pay attention to the following installation procedures. If not, it may drop from the panel, resulting in a serious accident.

■ **PC-RLH9**

- 1) Install the wireless receiver kit, the indoor unit and the air panel at the same time.
- 2) In case that the wireless receiver kit is installed after installing the indoor unit, turn off the power source of the indoor unit and remove the air inlet grille.
- 3) Fix the wireless receiver kit to the air panel by screws.  
(The tightening torque must be 0.8 Nm.)

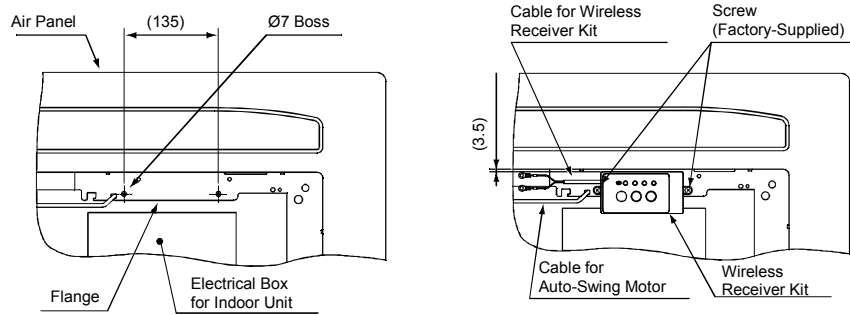

- 4) Lead the cable along the cable for the auto-swing motor and tie them by the band.

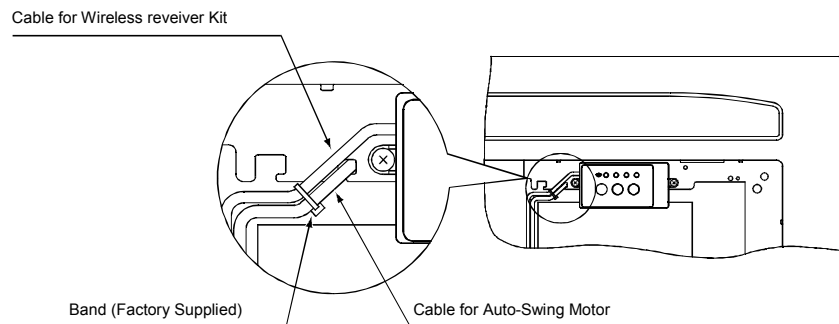

- 5) Remove the cover of indoor unit electrical control box and connect the cable to the terminals A and B of the terminal board.



**NOTE:**  
After connecting the cable, bind up the remaining cable length portion by band (Factory-Supplied) and put them in the electrical control box.

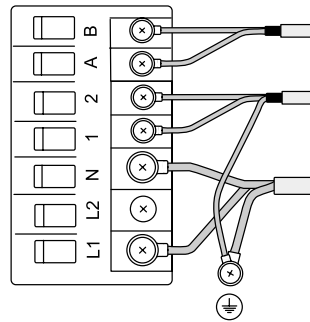

- 6) Remove the remote control cover of the air intake grille.
  - Press the hooks of the remote control cover by hand.

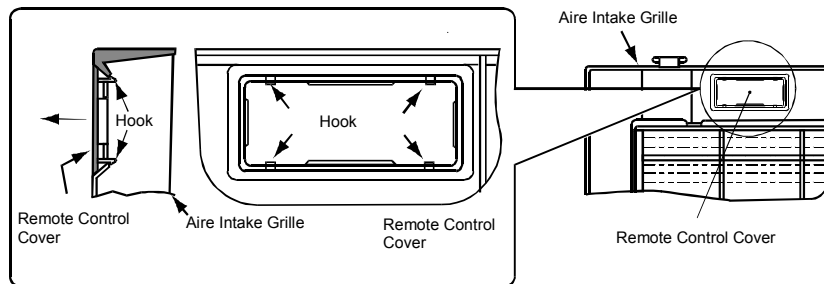

- 7) After fixing the air panel, attach the air intake grille to the air panel.
  - Check to ensure that the location of square hole of the air intake grille coincides with location of the wireless receiver kit of the air panel.
  - Check to ensure that the cable of the wireless receiver kit is not clamped by the square hole of the air intake grille.

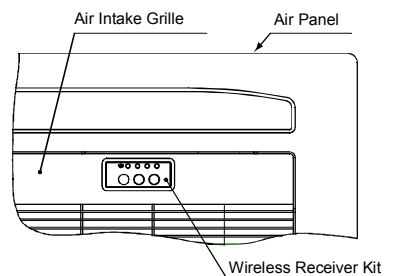

## 4 OPERATION & INSTALLATION MANUAL FOR PC-RLH9/11

### ■ PC-RLH11



#### NOTE:

Install the receiver kit onto the wall or ceiling near the indoor unit.

1. Install the wireless receiver kit and indoor unit at the same time.
2. In case that the wireless receiver kit is installed after installing the indoor unit, turn off the power source of the indoor unit.
3. Check to ensure that the distance between the wireless receiver kit and the indoor unit is less than 5 m.
4. Remove the cover by using minus screw-driver.

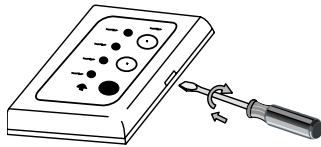

5. Install the wireless receiver kit onto the wall or ceiling as follows:

#### A. In Case of Exposing Cable

1. Fix the fixing bracket of kit by using screw (A) at 4 locations

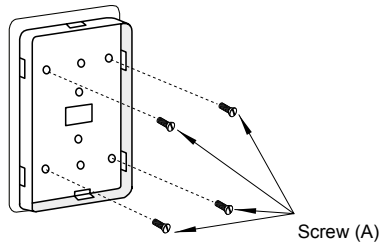

2. Cut one of the knockout holes (\*) at the cover.

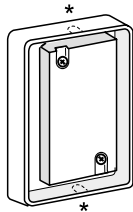

3. Lead the cable through the groove and draw out the cable from the knockout hole.

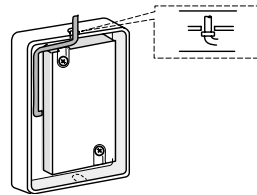

4. Attach the cover. Do not clamp the cable when attaching the cover.

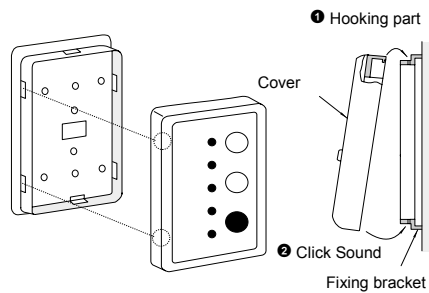

#### B. In Case of Concealed Cable

1. Prepare the following box. (Field-Supplied)

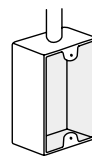

- JIS Box (JIS C 8336-1991)
1. Switch Box for 1 Controller (without Cover)
  2. Small Switch Box for 1 Controller (without Cover)
  3. Switch Box for 1 Controller (with Cover)

- Rigid Metal Conduit (More than  $\varnothing 20$ )
- Screw (M4) (Field-Supplied)



- 2 Insert the cable into the rigid metal conduit.

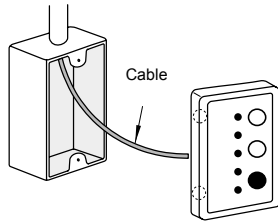

- 3 Fix the fixing bracket of kit by using screw (Field-Supplied).

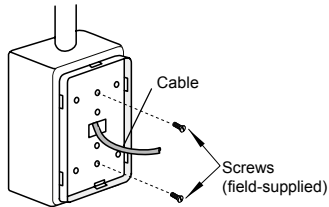

This figure shows the case of Switch Box for 1 Controller.

- 4 Attach the cover same as A 4.

6. Remove the cover of indoor unit electrical control box and connect the cable to the terminals A and B of the terminal board.



**NOTE:**

1. In case of RPK model, connect the cable to the indoor unit PCB connector CN13 (Blue 3P) by using the cable with a connector (Factory-Supplied with RPK).
2. After connecting the cable, bind up the remaining cable length portion by band (Factory-Supplied) and put them in the electrical control box.

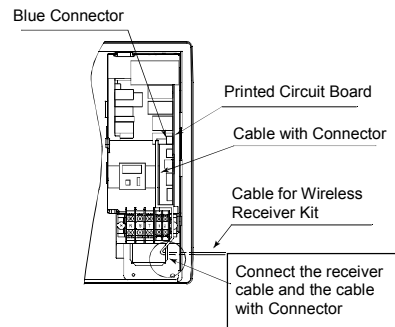
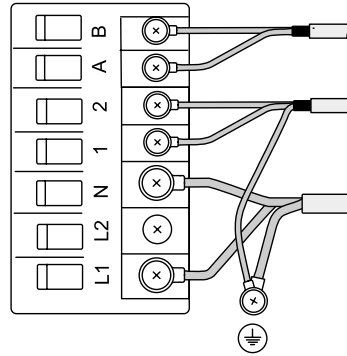

Example: RPK-FSG2M,

## 4 OPTIONAL FUNCTIONS

1) Open the lid of case by removing two screws so that the following functions are available.

### ■ PC-RLH9

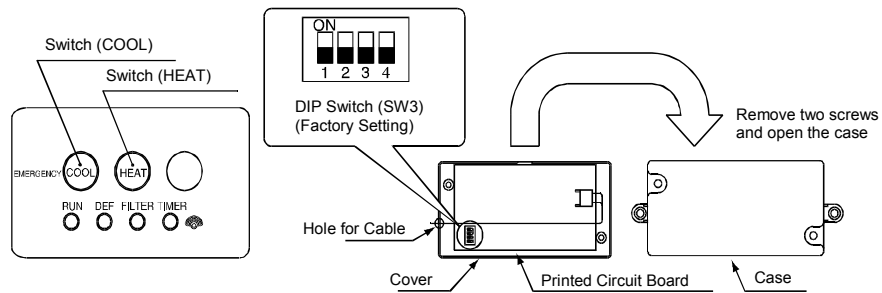

### ■ PC-RLH11

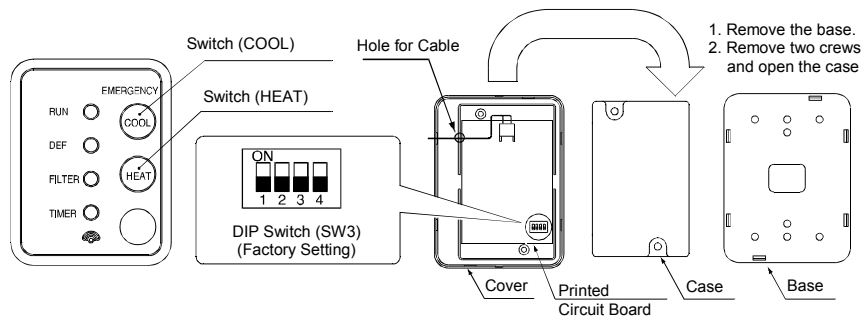

2) Optional Setting for Dip Switch (SW3)

Operation Function	DIP Switch Setting (SW3)
Setting of Sub Receiver kit	
Identifying of Indoor Units	

## 5 OTHERS

- 1) Proceed the "TEST RUN" mode by using "Operation & Installation Manual" for the wireless remote control switch (PC-LH3A).
  - Turn OFF all power sources before setting the dip switches.
- 2) Emergency Operation Setting (Refer to the figure of the item 3 "Optional Functions".)
 

In case that PC-LH3A is unusable by batteries shortage, etc., perform emergency operation as follows.

  - (1) Switch "COOL": Press "COOL" so that the cooling operation is started.  
Press "COOL" again so that the cooling operation is stopped.
  - (2) Switch "HEAT": Press "HEAT" so that the heating operation is started.  
Press "HEAT" again so that the heating operation is stopped.



### NOTE:

During the emergency operation, the LED (yellow) blinks (0.5 second ON / 0.5 second OFF).

- 3) Alarm Code Indication
  - In case that some trouble occurs because of activation of safety device, etc., "RUN" (red lamp) blinks (0.5 second ON / 0.5 second OFF).
  - Refer to the Installation Manual for outdoor unit about Alarm Code List.
  - Alarm Code indicates the blinking times of "DEF" (green lamp) and "FILTER" (yellow lamp) as shown below.
 

"DEF" (green lamp):	The blinking is shown at the 2 digit of Alarm Code
"FILTER" (yellow lamp):	The blinking is shown at the 1 digit of Alarm Code
	(Alphabet Code: A=10 times, B=11 times, C=12 times, ....)

- Example -

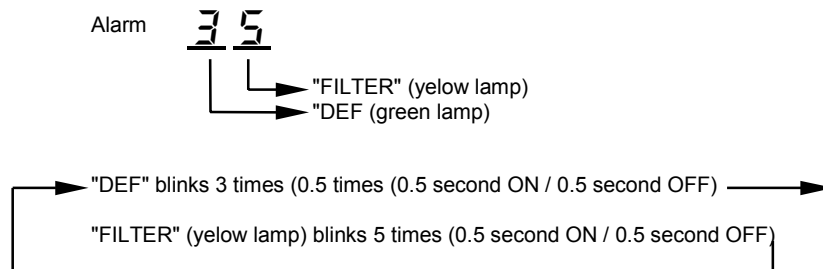

- "RUN" (red lamp) (1 second ON / 1 second OFF) indicates abnormal transmitting between Indoor Units and Outdoor Unit.

