





## 1. INSTALLATION OF REMOTE CONTROL SWITCH <PC-2H2>

### DANGER:

- DO NOT pour water into the remote controller (hereafter called "controller"). These products are equipped with electrical parts. If poured, it will cause a serious electrical shock.
- DO NOT operate switches by wet hand. It may cause an electrical shock.
- In case that the protective devices often function or the operation switches do not function well, turn OFF the main power supply and contact your distributor or dealer of HITACHI.
- In case that other abnormalities are found, stop the system, turn OFF the main power supply and contact your distributor or dealer of HITACHI.

### WARNING:

- DO NOT perform installation work and electrical wiring connection by yourself.
- In case that a service work such as repair, maintenance, etc. is required, contact your distributor or dealer of HITACHI.
- DO NOT modify the electrical wiring. It may cause serious accidents.

### CAUTION:

- DO NOT install the controller and cable at such places as;
  - (1) where there is oil vapor and the oil is dispersed.
  - (2) where the hot springs are near (in a sulfuric environment).
  - (3) where generation, flowing, staying or leaking of flammable gas is detected.
  - (4) where the sea is near (in the salty environment).
  - (5) an acid or alkaline environment.
- DO NOT install the indoor unit, outdoor unit, controller and cable within approximately 3 meters from strong electromagnetic wave radiators such as medical equipment.
- DO NOT use the multi-core wire for electrical wiring. If used, some signals of one system transfer to the other system, the signals interfere each other and it cause the malfunction.
- DO NOT use thin shield wire such as CPEVS. Such wires with big electrostatic capacity make the transmission signal dull and the transmission error may occur in case of long distance wiring.
- DO NOT run any cable for transmission and signal along the power line (220-240V, 380-415V).
- DO NOT run any cable for transmission and signal along other cables for transmission and signal. If the cables are required to be run along, keep a distance more than 30 cm between each cables, or insert the cables for each transmission system into the metal conduit tube and ground one end of the conduit tube.

### ■ Location of Remote Controller

1. Select a suitable place for handling and determine the installation place of the controller with the customer's acceptance.

Do not install the controller at such places as;

- where children can touch
- where the air from the air conditioner is directly discharged
- where there is oil vapor and the oil is dispersed
- where the humidity is high.

Especially in case that a remote control thermostat is used, select the installation place in consideration with the following points;

- where the average room temperature can be detected
- where the thermostat is not exposed directly to the sun
- where the heat sources is not near around
- where the thermostat is not affected with the outdoor air by opening and closing doors
- where the air from the air conditioner is directly discharged

2. Pay attention to the following points in case that the controller is installed in a place where there is medical equipment radiating electromagnetic waves.
  - DO NOT install the controller in a place where electromagnetic waves are radiated directly toward the remote control cable and the controller.
  - Keep a distance more than 3 meters away from the equipment radiating electromagnetic waves.
  - Keep a distance more than 3 meters away from the receiver such as radio. It may cause noises.
  - Shield the controller and cables by covering with the steel box and running the cable through the metal conduit tube.
  - In case that there is electric noise at the power source for the indoor unit, provide a noise filter.
  - In case of installing the wireless remote control switch onto the wall, keep a distance more than 30 cm from the power line.

### 1.1. BEFORE INSTALLATION

Check the contents and the number of the accessories in the packing.

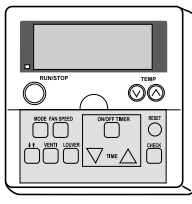
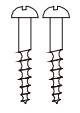
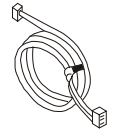
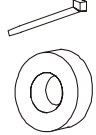
			
1 Remote Control Switch, for Operation Control	2 screws ø4x16L For fixing the Holding Bracket onto the wall	1 Remote Control Cable (8 m) for connection	1 Ring Core and 1 Fixing Band

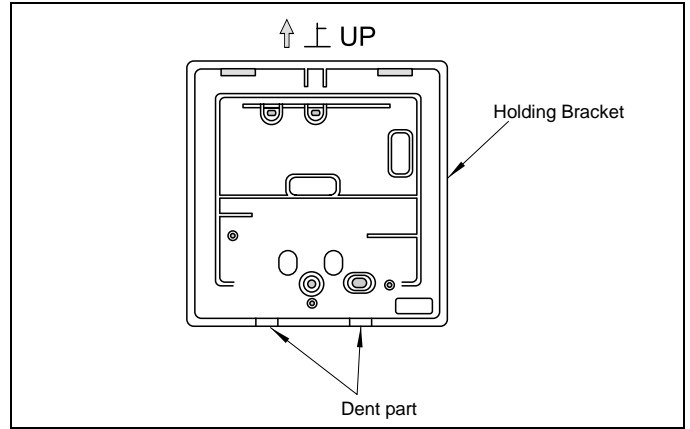

Fig. 3 Installation Procedure

### 1.2. INSTALLATION SPACE

In case of installing the controllers in vertical line, keep a distance more than 10 mm between the controllers vertically. If the distance is insufficient, the front cover of the controller can not open wide enough

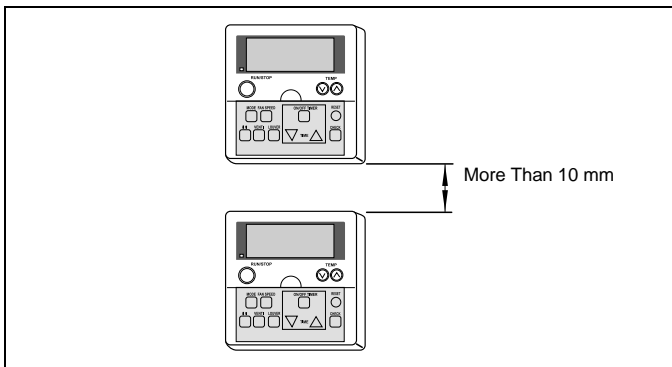

Fig. 1 Installation Space

2. Attach the controller to the holding bracket as follows.

A. In case of exposing Remote Control Cable.

① Fix the holding bracket onto the wall as shown below

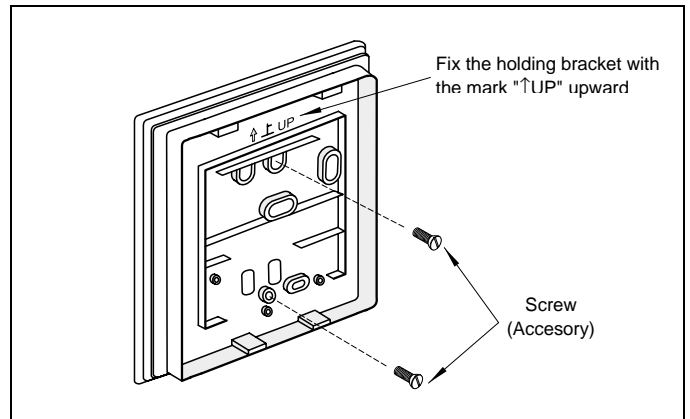

Fig. 4 Attach the controller

② Make the hole for drawing out the cable

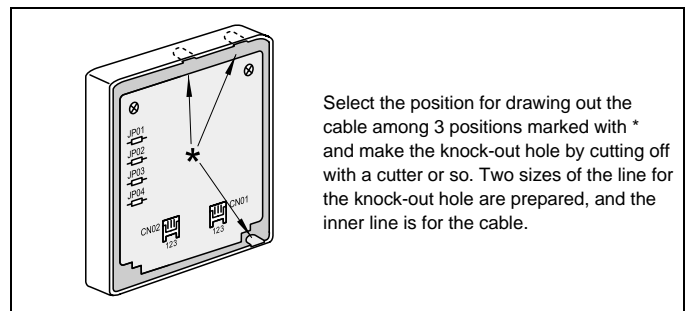

Fig. 5 Drawing out the cable

### 1.3. INSTALLATION PROCEDURE

1. Insert the edge of the flat head screwdriver into the dent parts at the bottom of the holding bracket, push and turn the screwdriver and remove the controller from the holding bracket as shown in the figure below.

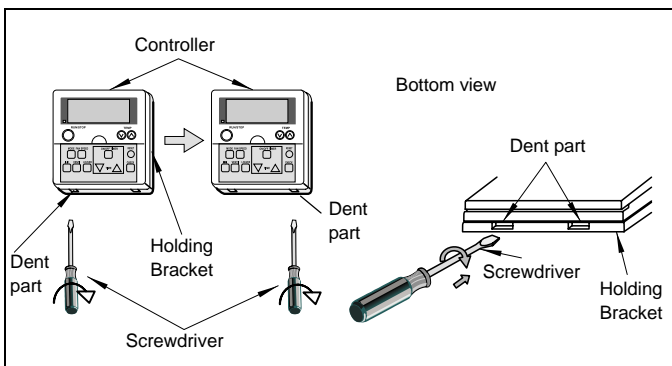

Fig. 2 Installation Procedure

- 3 Connect the cable to the PCB connector (yellow) of the controller, run the cable through the groove at the backside of the casing and draw out the cable from the casing.

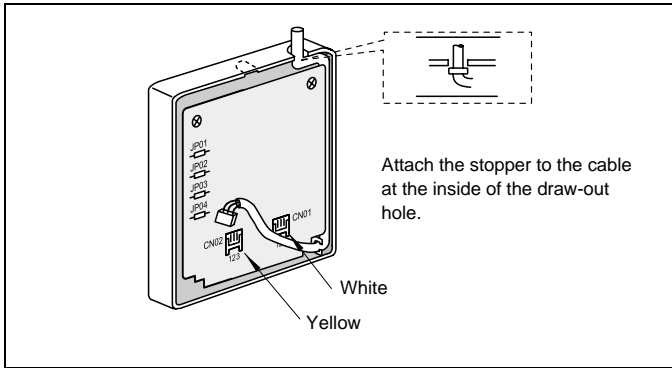

Fig. 6 PCB connector

- 4 Attaching Procedures

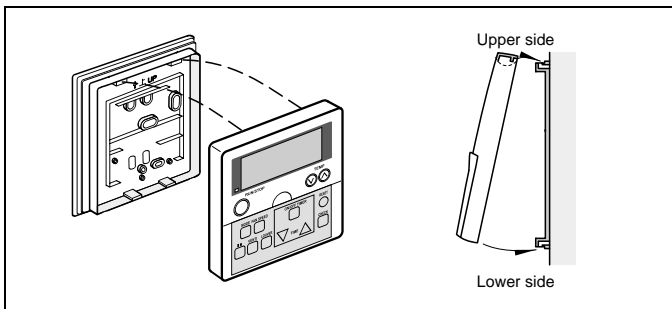

Fig. 7 Attaching Procedures

- Step 1: Insert the hooks of the controller to the holes on the top of the holding bracket.
- Step 2: Push the lower part toward the holding bracket.
- Step 3: When the click sound is heard, the controller is attached to the holding bracket and the mounting work is finished. Check to ensure that the 4 hooks at the position \* are correctly inserted.

**B. When Using Switch Box.**

- 1 Field-Supplied JIS Box (JIS 8336 - 1998)

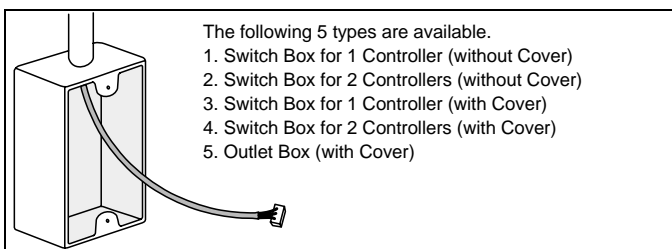

Fig. 8 Running the cable through the conduit tube in the wall

- 2 Fix the holding bracket to the switch box

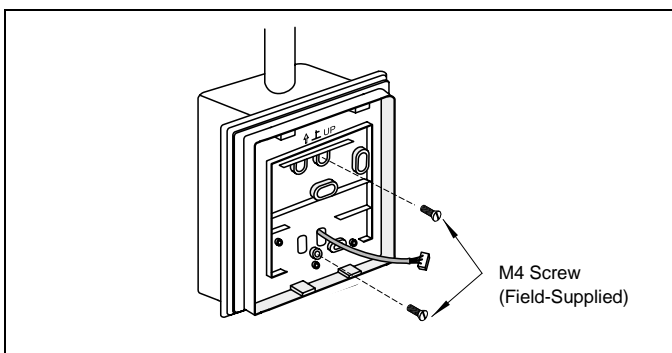

Fig. 9 Fixing the holding bracket

- 3 Mounting procedures.

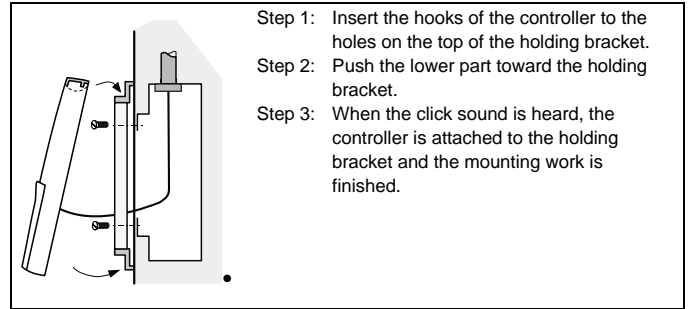

Fig. 10 Mounting procedures

**CAUTION:**

Pay attention so that the cable may not be slack. If the cable is slack as shown in the above figure, the cable cord (especially the naked part) may be clamped at the hole and it may cause a faulty operation.

**1.4. WIRING SYSTEM FOR REMOTE CONTROL SWITCH (PC-2H2)**

**1.4.1. LENGTH OF WIRE CABLE FOR REMOTE CONTROL SWITCH**

Length of the standard wire cable for the optional remote control switch is 8 meters.

Extension up to 500 meters (with 0.75mm<sup>2</sup> CVS wire) is available.

Indoor Unit: 1 set

Remote Control Switch: 1 set

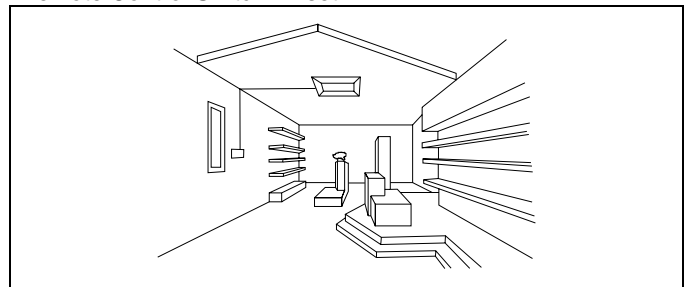

Fig. 11 Length of Wire Cable for Remote Control Switch

**1.4.2. ELECTRICAL WIRING**

Attach the Ring Core (black) (accessory) when installing the unit.

- Insert the remote control cable into the ring core 2 turns as shown below before connecting to the PCB. Fix the cable by using the band (accessory).

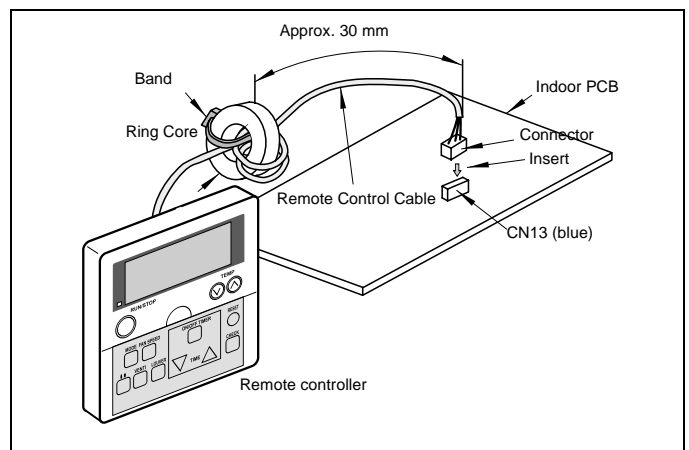

Fig. 12 Electrical Wiring

### 1.4.3. ONE REMOTE CONTROL SWITCH FOR MULTIPLE UNITS

This remote control switch can control sixteen units, as the maximum.

In case of this modification, wiring connection and other works shall be performed as indicated in the following procedures.

#### Wiring Connection for Control Circuit

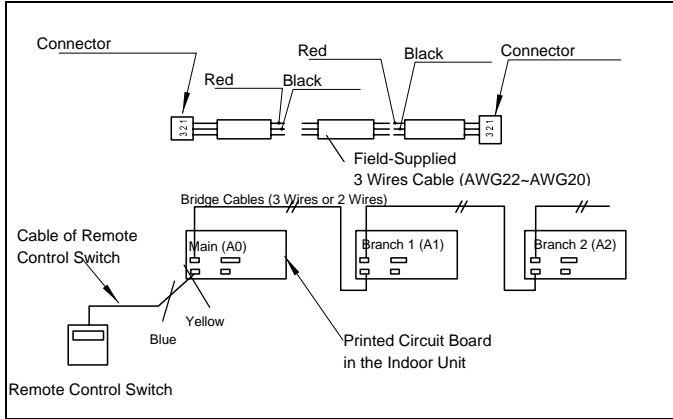

Fig. 13 Wiring connection

1. The power source cable and the bridge cable between the indoor unit(s) and the outdoor unit(s) should be performed in accordance with the installation manual of the unit.
2. The cables (0.3 mm<sup>2</sup> wire) of different length are prepared as an option, which are fitted with connectors.

Cable Model	PRC-10E	PRC-15E	PRC-20E	PRC-30E
Length (m)	10	15	20	30

In case that a longer cable is required, the additional field-supplied cable shall be connected as following procedure.

- A. Prepare the cable with two wires.
  - B. After checking the color of the wires, connect each wire of the same color by soldering.
  - C. Insulate the soldered parts and the wires with insulation tape.
  - D. The maximum total cable length of the remote control switch cable and the bridge cable(s) is 200 meters(0.3mm<sup>2</sup> wire) or 500 meters(0.75mm<sup>2</sup> wire).
3. Separate the cable more than approximately 30cm from any wires which are utilized for wires higher than 220V, or put the cable in a metal tube and earth the tube.
  4. Set the serial unit number by adjusting the "DSW" dip switch on the printed circuit board(s) in the indoor unit(s). This setting should be matched with the serial number of the bridge cable(s).

#### Setting of dip switch:

<b>A0</b>	<b>A1</b>	<b>A2</b>	<b>A3</b>
ON OFF <input type="checkbox"/> <input type="checkbox"/> <input type="checkbox"/> <input type="checkbox"/>	ON OFF <input type="checkbox"/> <input type="checkbox"/> <input type="checkbox"/> <input type="checkbox"/>	ON OFF <input type="checkbox"/> <input type="checkbox"/> <input type="checkbox"/> <input type="checkbox"/>	ON OFF <input type="checkbox"/> <input type="checkbox"/> <input type="checkbox"/> <input type="checkbox"/>
<b>A4</b>	<b>A5</b>	<b>A6</b>	<b>A7</b>
ON OFF <input type="checkbox"/> <input type="checkbox"/> <input type="checkbox"/> <input type="checkbox"/>	ON OFF <input type="checkbox"/> <input type="checkbox"/> <input type="checkbox"/> <input type="checkbox"/>	ON OFF <input type="checkbox"/> <input type="checkbox"/> <input type="checkbox"/> <input type="checkbox"/>	ON OFF <input type="checkbox"/> <input type="checkbox"/> <input type="checkbox"/> <input type="checkbox"/>
<b>A8</b>	<b>A9</b>	<b>AA</b>	<b>Ab</b>
ON OFF <input type="checkbox"/> <input type="checkbox"/> <input type="checkbox"/> <input type="checkbox"/>	ON OFF <input type="checkbox"/> <input type="checkbox"/> <input type="checkbox"/> <input type="checkbox"/>	ON OFF <input type="checkbox"/> <input type="checkbox"/> <input type="checkbox"/> <input type="checkbox"/>	ON OFF <input type="checkbox"/> <input type="checkbox"/> <input type="checkbox"/> <input type="checkbox"/>
<b>AC</b>	<b>Ad</b>	<b>AE</b>	<b>AF</b>
ON OFF <input type="checkbox"/> <input type="checkbox"/> <input type="checkbox"/> <input type="checkbox"/>	ON OFF <input type="checkbox"/> <input type="checkbox"/> <input type="checkbox"/> <input type="checkbox"/>	ON OFF <input type="checkbox"/> <input type="checkbox"/> <input type="checkbox"/> <input type="checkbox"/>	ON OFF <input type="checkbox"/> <input type="checkbox"/> <input type="checkbox"/> <input type="checkbox"/>

1.5. TEST RUN PROCEDURE BY REMOTE CONTROL SWITCH

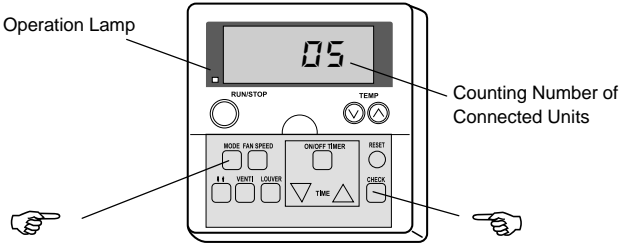
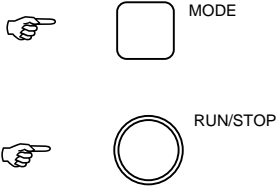
<b>1</b>	Turn ON the power source of the Indoor and Outdoor Units																									
<b>2</b>	Set the TEST RUN mode by remote control switch. Depress the "MODE" and the "CHECK" switches simultaneously for more than 3 seconds. <ol style="list-style-type: none"> <li>If "TEST RUN" and the counting number of the connected units to the remote control switch (for example "05") are indicated on the remote control switch, the connection of remote control cable is correct. Go to <b>4</b></li> <li>If no indication or "00" appear or the number of the units indicated is smaller than the actual number of the units, some abnormalities exist. Go to <b>3</b></li> </ol>																									
<b>3</b>	<table border="1"> <thead> <tr> <th>Remote Control Switch Indication</th> <th>Fault</th> <th>Inspection Points after Power Source OFF</th> </tr> </thead> <tbody> <tr> <td data-bbox="188 835 316 857">No indication</td> <td data-bbox="371 757 746 947">                             (1) The power source is not turned ON.                              (2) The connection of the remote control cable is incorrect.                              (3) The connecting wires of power supply line are incorrect or loosened.                         </td> <td data-bbox="762 768 1297 936">                             1. Connection between the connector and the wires: Red wire-No. 1, Black wire-No. 2, White wire-No. 3                              2. Connecting Points of Remote Control Cable                              3. Contact of Connectors of Remote Control Cable                              4. Connection Order of each Terminal Board                              5. Screw Fastening of each Terminal Boards.                         </td> </tr> <tr> <td data-bbox="156 1003 347 1081">Counting number of connected units is incorrect</td> <td data-bbox="371 947 746 1137">                             (4) The setting of unit number is incorrect                              (5) The connection of control cables between each indoor units are incorrect. (When one remote control switch controls multiple units)                         </td> <td data-bbox="762 992 1217 1104">                             6. Dip Switch Setting on Printed Circuit Board                              7. Wire Connecting Order of Bridge cable                              8. Connecting Points of Bridge Cable                              9. Contact of Connectors of Bridge Cable                         </td> </tr> </tbody> </table>	Remote Control Switch Indication	Fault	Inspection Points after Power Source OFF	No indication	(1) The power source is not turned ON. (2) The connection of the remote control cable is incorrect. (3) The connecting wires of power supply line are incorrect or loosened.	1. Connection between the connector and the wires: Red wire-No. 1, Black wire-No. 2, White wire-No. 3 2. Connecting Points of Remote Control Cable 3. Contact of Connectors of Remote Control Cable 4. Connection Order of each Terminal Board 5. Screw Fastening of each Terminal Boards.	Counting number of connected units is incorrect	(4) The setting of unit number is incorrect (5) The connection of control cables between each indoor units are incorrect. (When one remote control switch controls multiple units)	6. Dip Switch Setting on Printed Circuit Board 7. Wire Connecting Order of Bridge cable 8. Connecting Points of Bridge Cable 9. Contact of Connectors of Bridge Cable																
Remote Control Switch Indication	Fault	Inspection Points after Power Source OFF																								
No indication	(1) The power source is not turned ON. (2) The connection of the remote control cable is incorrect. (3) The connecting wires of power supply line are incorrect or loosened.	1. Connection between the connector and the wires: Red wire-No. 1, Black wire-No. 2, White wire-No. 3 2. Connecting Points of Remote Control Cable 3. Contact of Connectors of Remote Control Cable 4. Connection Order of each Terminal Board 5. Screw Fastening of each Terminal Boards.																								
Counting number of connected units is incorrect	(4) The setting of unit number is incorrect (5) The connection of control cables between each indoor units are incorrect. (When one remote control switch controls multiple units)	6. Dip Switch Setting on Printed Circuit Board 7. Wire Connecting Order of Bridge cable 8. Connecting Points of Bridge Cable 9. Contact of Connectors of Bridge Cable																								
Back to <b>1</b> after checking																										
<b>4</b>	Select TEST RUN MODE by depressing MODE Switch (COOL OR HEAT)																									
<b>5</b>	Depress RUN/STOP switch. <ol style="list-style-type: none"> <li>The "TEST RUN" operation will be started. (The "TEST RUN" operation will be finished after 2 hours unit operation or by depressing the RUN/STOP switch again).</li> <li>IF the unit do not start or the operation lamp on the remote control switch is flickered, some abnormalities exist. Go to <b>6</b></li> </ol>																									
<b>6</b>	<table border="1"> <thead> <tr> <th>Remote Control Switch Indication</th> <th>Unit Condition</th> <th>Fault</th> <th>Inspection Points after Power Source OFF</th> </tr> </thead> <tbody> <tr> <td data-bbox="156 1552 395 1664">The operation lamp flickers. (1 time/1 sec.) And the Unit No. and Alarm Code "03" flicker</td> <td data-bbox="403 1585 746 1619">The unit does not start.</td> <td data-bbox="762 1563 1026 1641">The connecting wires of operating line are incorrect or loosened.</td> <td data-bbox="1050 1507 1465 1697">                             1. Connecting Order of each Terminal Boards.                              2. Screw fastening of each Terminal Boards.                              3. Connecting Order of Power Line Between Indoor Units and Outdoor Unit.                         </td> </tr> <tr> <td data-bbox="156 1697 395 1776">The operation lamp flickers. (1 time/2 sec.)</td> <td data-bbox="403 1720 746 1753">The unit does not start.</td> <td data-bbox="762 1709 1026 1765">The connection of remote control cable is incorrect</td> <td data-bbox="1050 1720 1465 1753">This is the same as item <b>3</b> 1, 2, and 3</td> </tr> <tr> <td data-bbox="156 1821 395 1877">Indication of clicker different to above</td> <td data-bbox="403 1821 746 1877">The unit does not start, or start once and the stops</td> <td data-bbox="762 1787 1026 1910">The connection of thermistor or other connectors are incorrect. Tripping of protector exists, or else.</td> <td data-bbox="1050 1821 1465 1877">Check by the alarm code table in the service manual (Do it by service people).</td> </tr> <tr> <td data-bbox="156 1977 228 2011" rowspan="2">Normal</td> <td data-bbox="403 1933 746 1966">The outdoor fans rotate reversely</td> <td data-bbox="762 1921 1026 2000">The connection order of power supply line is incorrect.</td> <td data-bbox="1050 1921 1465 1977">Connecting Order of the Terminal Board: TB1 in the Outdoor Unit</td> </tr> <tr> <td data-bbox="403 2022 746 2056">The outdoor fans do not start.</td> <td data-bbox="762 2000 1026 2078">Some wires of power supply line are disconnected.</td> <td data-bbox="1050 2011 1465 2067">Connecting Point of Power Supply Line. Contact Outdoor Fan Motor Connector.</td> </tr> </tbody> </table>	Remote Control Switch Indication	Unit Condition	Fault	Inspection Points after Power Source OFF	The operation lamp flickers. (1 time/1 sec.) And the Unit No. and Alarm Code "03" flicker	The unit does not start.	The connecting wires of operating line are incorrect or loosened.	1. Connecting Order of each Terminal Boards. 2. Screw fastening of each Terminal Boards. 3. Connecting Order of Power Line Between Indoor Units and Outdoor Unit.	The operation lamp flickers. (1 time/2 sec.)	The unit does not start.	The connection of remote control cable is incorrect	This is the same as item <b>3</b> 1, 2, and 3	Indication of clicker different to above	The unit does not start, or start once and the stops	The connection of thermistor or other connectors are incorrect. Tripping of protector exists, or else.	Check by the alarm code table in the service manual (Do it by service people).	Normal	The outdoor fans rotate reversely	The connection order of power supply line is incorrect.	Connecting Order of the Terminal Board: TB1 in the Outdoor Unit	The outdoor fans do not start.	Some wires of power supply line are disconnected.	Connecting Point of Power Supply Line. Contact Outdoor Fan Motor Connector.		
Remote Control Switch Indication	Unit Condition	Fault	Inspection Points after Power Source OFF																							
The operation lamp flickers. (1 time/1 sec.) And the Unit No. and Alarm Code "03" flicker	The unit does not start.	The connecting wires of operating line are incorrect or loosened.	1. Connecting Order of each Terminal Boards. 2. Screw fastening of each Terminal Boards. 3. Connecting Order of Power Line Between Indoor Units and Outdoor Unit.																							
The operation lamp flickers. (1 time/2 sec.)	The unit does not start.	The connection of remote control cable is incorrect	This is the same as item <b>3</b> 1, 2, and 3																							
Indication of clicker different to above	The unit does not start, or start once and the stops	The connection of thermistor or other connectors are incorrect. Tripping of protector exists, or else.	Check by the alarm code table in the service manual (Do it by service people).																							
Normal	The outdoor fans rotate reversely	The connection order of power supply line is incorrect.	Connecting Order of the Terminal Board: TB1 in the Outdoor Unit																							
	The outdoor fans do not start.	Some wires of power supply line are disconnected.	Connecting Point of Power Supply Line. Contact Outdoor Fan Motor Connector.																							
Back to <b>1</b> after checking																										

## 2. CHECK FUNCTION USING THE REMOTE CONTROL

### 2.1. ALARM CODES

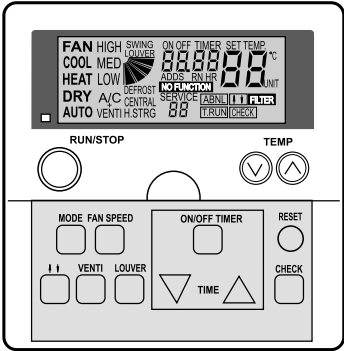
Indication	Trouble	Possible Causes	Action																																
RUN lamp Flashes for 2 Seconds	Failure in Transmission Between Indoor Unit and Remote Control Switch	Remote cable broken Contact Failure in Remote control cable	Locate the cause and repair.																																
RUN lamp flashes 5 times (5 seconds) with unit number and alarm code displayed	Failure (see Code)	IC or Microcomputer defective	Check by remote control self-checking function																																
 <p>Example: <b>A3</b> Unit N° 3</p> <p><b>02</b> Alarm Code of "outdoor Unit Protection Activated"</p>		<p>Indication of unit number in remote control switch <b>master or single unit.</b></p> <table border="1"> <thead> <tr> <th>Unit 0</th> <th>Unit 1</th> <th>Unit 2</th> <th>Unit 3</th> <th>Unit 4</th> <th>Unit 5</th> <th>Unit 6</th> <th>Unit 7</th> </tr> </thead> <tbody> <tr> <td>A0</td> <td>A1</td> <td>A2</td> <td>A3</td> <td>A4</td> <td>A5</td> <td>A6</td> <td>A7</td> </tr> </tbody> </table> <p>Indication of unit number in remote control switch <b>slave or single unit.</b></p> <table border="1"> <thead> <tr> <th>Unit 8</th> <th>Unit 9</th> <th>Unit 10</th> <th>Unit 11</th> <th>Unit 12</th> <th>Unit 13</th> <th>Unit 14</th> <th>Unit 15</th> </tr> </thead> <tbody> <tr> <td>A8</td> <td>A9</td> <td>AA</td> <td>Ab</td> <td>AC</td> <td>Ad</td> <td>AE</td> <td>AF</td> </tr> </tbody> </table>		Unit 0	Unit 1	Unit 2	Unit 3	Unit 4	Unit 5	Unit 6	Unit 7	A0	A1	A2	A3	A4	A5	A6	A7	Unit 8	Unit 9	Unit 10	Unit 11	Unit 12	Unit 13	Unit 14	Unit 15	A8	A9	AA	Ab	AC	Ad	AE	AF
Unit 0	Unit 1	Unit 2	Unit 3	Unit 4	Unit 5	Unit 6	Unit 7																												
A0	A1	A2	A3	A4	A5	A6	A7																												
Unit 8	Unit 9	Unit 10	Unit 11	Unit 12	Unit 13	Unit 14	Unit 15																												
A8	A9	AA	Ab	AC	Ad	AE	AF																												

#### Alarm Codes

Code	Cause	Model
01	Safety Device of the Indoor Unit is tripped (internal Thermostat, *Float Switch)	Heat Pump & Twin
02	Safety Device of the Outdoor Unit is tripped (High pressure switch, Internal Thermostat for Outdoor Fan Motor and Overcurrent Relay)	Heat Pump & Twin
	Safety Device of the Outdoor Unit is tripped (Overcurrent Relay, Compressor Chamber Thermostat, High Pressure Switch and Internal Thermostat for Outdoor and Indoor Fan Motor)	Cooling Only Models
03	Transmission Abnormality between Indoor Unit and Outdoor Unit	Heat Pump & Twin
05	Picking up phase Abnormality	Heat Pump & Twin
08	Abnormality High Temperature on the Top of Compressor	Heat Pump & Twin
11	Thermistor Abnormality for inlet Air Temperature	All Models
12	Thermistor Abnormality for outlet Air Temperature	Heat Pump & Twin
13	Thermistor Abnormality for Freezing Temperature	All Models
20	Thermistor Abnormality for Compressor Top Temperature	Heat Pump & Twin
22	Thermistor Abnormality for Outdoor Air Temperature	Heat Pump & Twin
24	Thermistor Abnormality for Outdoor Evaporating Temperature (defrosting)	Heat Pump & Twin
25	Thermistor Abnormality for Condensing Temperature	Heat Pump & Twin
32	Transmission Abnormality between Master and Slave	Only Twin system
38	Abnormality in the Picking up Circuit protection	All Models
41	Excessive Overload during Cooling Operation	Heat Pump & Twin
42	Excessive Overload during Heating Operation	Heat Pump & Twin

(\* Only for RCI models & RPI with Drain Kit)

#### NOTES:

If an 02 cooling only models/05 heat pump models alarm code appears when the unit is operated for the first time, please check that incoming phases are correctly connected. Inverse 2 of the 3 phases and retry.



## 2.2. OPTIONAL FUNCTION SETTING

The remote control switch is changed to the optional setting mode by the following procedures.

### Field Setting Mode

Check to ensure that the unit is stopped, press the "CHECK" switch and the "RESET" switch on the remote control switch simultaneously more than 3 seconds, and the remote control switch is changed to the field setting mode. When the remote control switch is at the field setting mode, the "SERVICE" is indicated and the "01" is flickers below the "SERVICE" indication.

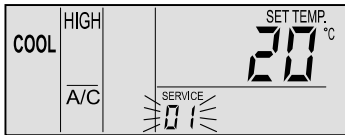

### Optional Setting Mode

At the field setting mode as described in Field Setting Mode, press the "TEMP Δ" switch or the "TEMP ∇" switch and the number flickering below the "SERVICE" indication is changed (01 <=> 02). Set the flickering number at "01", leave this condition for 7 seconds or press the "CHECK" switch, and the remote control switch is changed to the optional setting mode.

### Selection of Indoor Unit

a. At the optional setting mode, the indication on the remote control switch is changed as shown in the right figure.

- 1 The indication of "01" is turned
- 2 The address of the indoor unit which the optional function is to be set, is indicated at the segments for timer setting time indication, and the "ADDS" is indicated below.
- 3 The refrigerant cycle number of the indoor unit for which the optional function is to be set is indicated "-" and the "RN" is indicated below.
- 4 The indication of the setting temperature is turned OFF.

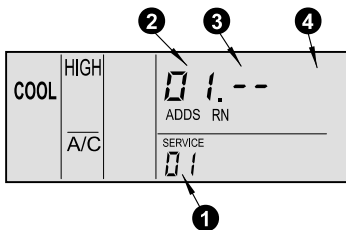

b. At the condition of the above item (a), press the "TEMP ∇" switch or the "TEMP Δ" switch of the remote control switch and the indoor unit for which the optional function is to be set, can be changed.

### NOTES:

The indoor unit can be selected among the indoor units connected to the remote control switch.

In case that both the indications of the address and the refrigerant cycle number is "AA", the settings of all the indoor units is same.

c. After selecting the indoor unit, leave the condition for 7 seconds or press the "CHECK" switch, the remote control switch is changed to the optional setting mode.

### Changing of Optional Functions and Setting Conditions

a. At the optional setting mode, the indication on the remote control switch is changed as shown below.

- 1 The indications of "ADDS" and "RN" are turned OFF.
- 2 The item number of the optional function is indicated at the segment for the setting temperature indication. Refer to the table in the next pages for the item numbers and the contents of the optional functions.
- 3 The setting condition of the optional function item is indicated at the segments for timer setting time indication. Refer to the table in the next pages and description of each items for the indication of the setting condition and the contents of the optional function.

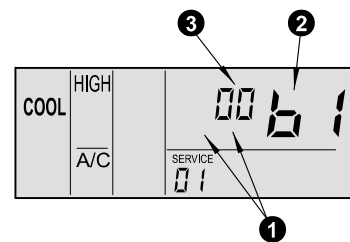

b. Press the "TIME ∇" switch or the "TIME Δ" switch, the optional function item is changed as shown below.

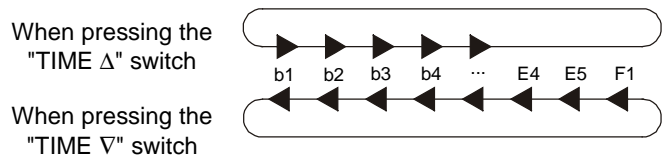

c. Press the "CHECK" switch, and the setting condition of the optional function is changed as shown below.

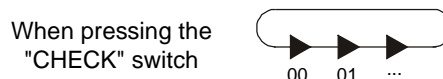

### ■ Selection of Other Indoor Unit

At the optional setting mode, press the "TIME ▽" switch or the "TIME △" switch, the condition of the remote control switch is changed so that the indoor unit can be selected to set the optional function described in the item (b) of "Selection of Indoor Unit".

### ■ Return from Optional Function Setting Mode

Press the "RESET" switch, the optional function setting is memorized and the mode is returned to the normal condition.

### ■ Setting Items of Optional Functions

Items	Optional Functions	Individual Setting	Setting Condition	Contents
b1	Removal of Heating Temperature Calibration	○	00 01	Not Available Available
b2	Circulation Function at Heating Thermo-OFF	○	00 01	Not Available Available
b3	Enforced 3 Minutes Minimum Operation Time of Compressor	○	00 01	Not Available Available
b4	Change of Filter Cleaning Time	○	00 01 02 03 04	Standard 100 hours 1200 hours 2500 hours Not Indication
b5	Fixing of Operation Mode	×	00 01	Not Available Available
b6	Fixing of Setting Temperature	×	00 01	Not Available Available
b7	Fixing of Operation as Exclusive Cooling Unit	×	00 01	Not Available Available
b8	Automatic COOL/HEAT	×	00 01	Not Available Available
b9	Fixing of Air Volume	×	00 01	Not Available Available
EB	Thermistor of Remote Control Switch	○	00 01 02	Control by Indoor Suction Thermistor Control by Remote Control Thermistor Control by Average
F1	Automatic Setting for OFF Timer	×	00 01 02 ~ 23 24	No Function OFF Timer by 1 Hour OFF Timer by 2 Hour  OFF Timer by 23 Hours OFF Timer By 24 Hours

#### NOTES:

As for optional functions with " × " at the individual setting, only when the "All Rooms" is selected to set the optional function, the setting condition can be changed.  
As for the items not indicated in the above table, the optional function is not available. Do not change the setting.



---

**HITACHI**