

HITACHI

Inspire the Next

INSTALLATION MANUAL FOR MULTI-KITS

Line Branch Models:

E-52XN2, E-102XN2, E-162XN2, E-202XN2, E-242XN2, E-322XN2



NOTE:

Hand over this installation manual to the next installation work personnel.

1 APPLICABLE OUTDOOR UNITS

These multiple pipe connecting kits can be applied to the R410A SET-FREE series.



CAUTION:

- Do NOT put any material on the product.

2 BEFORE INSTALLATION

- Confirm the number of the following parts by referring to the model printed on the package before unpacking.
- Do NOT put any foreign material into the parts.
- Check to confirm that no foreign materials are inside the parts before installation.



NOTE:

If any of these parts is not contained, please contact your distributor.

3 INSTALLATION WORK

3.1. PIPING CONNECTION SIZE

The ends of the multi-kits are finished as shown in the following figures. Cut the end of the pipe to meet with the pipe size.

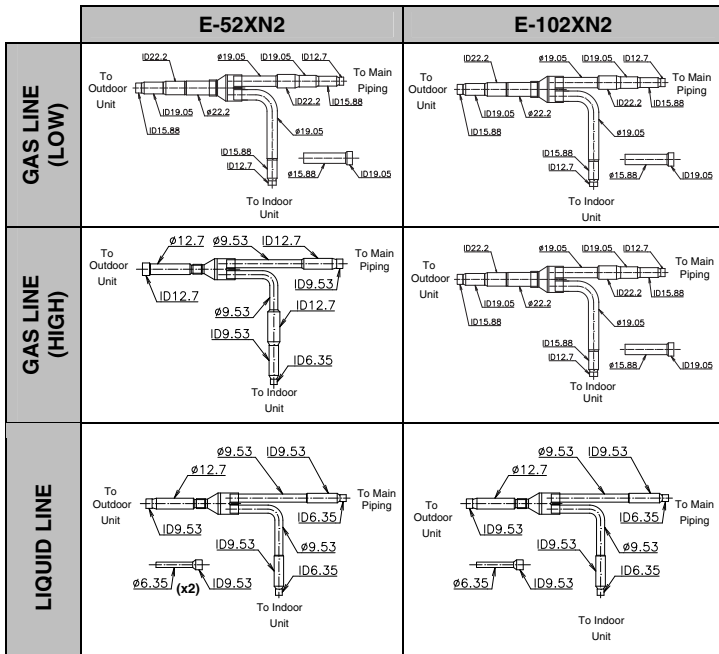

Unit: mm, ID: Inner Diameter

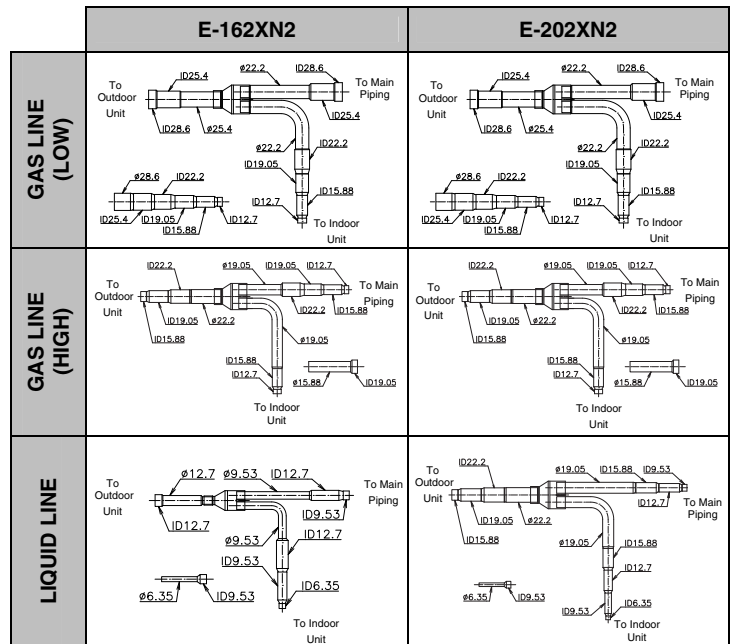

Unit: mm, ID: Inner Diameter

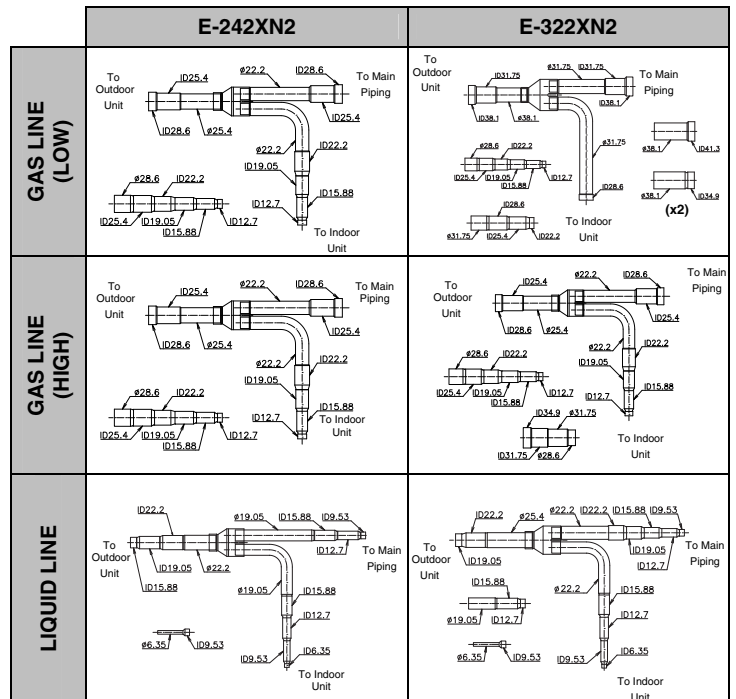

Unit: mm, ID: Inner Diameter

| Name of parts | E-52XN2 | E-102XN2 | E-162XN2 | E-202XN2 | E-242XN2 | E-322XN2 | Figure |
|--------------------------------|---------|----------|----------|----------|----------|----------|--------|
| Insulation for Gas Line (Low) | 1 | 1 | 1 | 1 | 1 | 1 | |
| Insulation for Gas Line (High) | 1 | 1 | 1 | 1 | 1 | 1 | |
| Insulation for Liquid Line | 1 | 1 | 1 | 1 | 1 | 1 | |
| Tape | 3 | 3 | 3 | 3 | 3 | 3 | |



CAUTION:

- Piping shall be supported with adequate space.
- Bent pipes and bypass piping (horizontal loop) shall also be installed in order to absorb piping elasticity caused by temperature changes.

3.2. INSTALLATION POSITION

1. Horizontal Installation

Locate the branch pipes on the same horizontal plane.
(Inclination within 30°)

Make the straight length a minimum of 0.5m after the vertical bend.

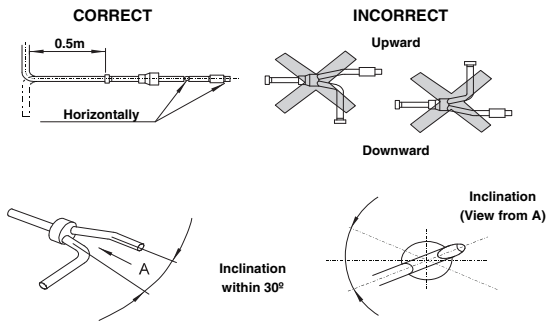

2. Vertical Installation

Straight length of the pipe connection on the outdoor unit side is made as follows:

- The collective pipe connection part is installed upward, the straight length must be min. 0.5m.
- The collective pipe connection part is installed downward, the straight length must be min. 0.3m.

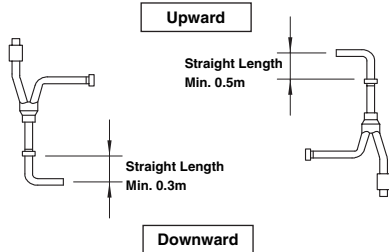

- When cutting the pipe, secure the adequate depth for brazing as shown in the following table.

| (mm) | |
|-------------------|------------------|
| A: Outer Diameter | B: Minimum depth |
| Over 5, below 8 | 6 |
| Over 8, below 12 | 7 |
| Over 12, below 16 | 8 |
| Over 16, below 25 | 10 |
| Over 25, below 35 | 12 |
| Over 35, below 45 | 14 |

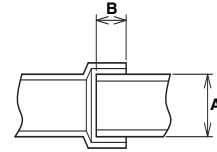

CAUTION for Refrigerant Piping:

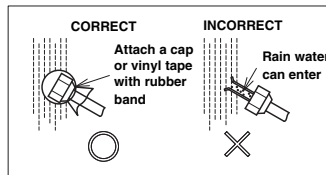
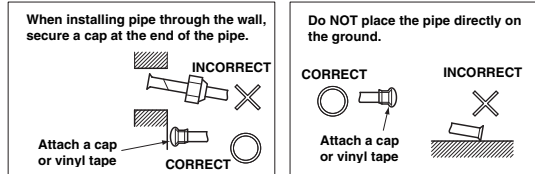

- Make sure that the stop valves are closed completely.
- Blow the inside of the pipes with nitrogen when brazing.

DANGER:

Check for the refrigerant leakage in detail. If a large refrigerant leakage occurs, it will cause difficulty with breathing or harmful gases would occur if a fire were being used in the room.

- The airtight test pressure of this product is 4.15MPa.
- Apply the insulation supplied with these multi-kits to each branch (liquid side and gas side) with a tape. Also apply the field-supplied insulation to the field-supplied pipes.

NOTE:

When polyethylene foam is applied, a thickness of 10mm for the liquid piping and 15mm to 20mm for the gas piping is recommended. (Use insulation for gas piping with a heat resistance of 100 °C).

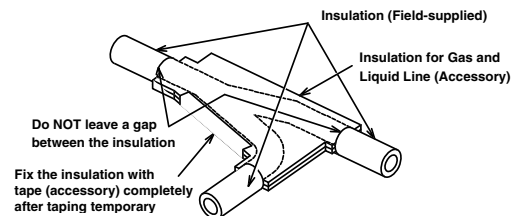

CAUTION:

- When the temperature of the piping decrease to room temperature, perform insulation work. If insulation work is performed immediately after brazing, insulation can melt.
- If the ends of piping system are open to the atmosphere for a while after accomplishing piping work, securely put caps or vinyl bags to the ends of the piping, avoiding the intrusion of moisture and dust.
- After installing work has been finished, it is recommended to keep this manual by a customer.

3.3. CONNECTION PROCEDURE FOR PIPING JOINT

When connecting liquid piping for the unit with a capacity 2.0HP or smaller, and with the length of piping is 15 meters or longer, apply the piping size of Ø9.53mm.

Fix the connecting pipe as shown in the below figure.

Use the insulation attached to the indoor unit.

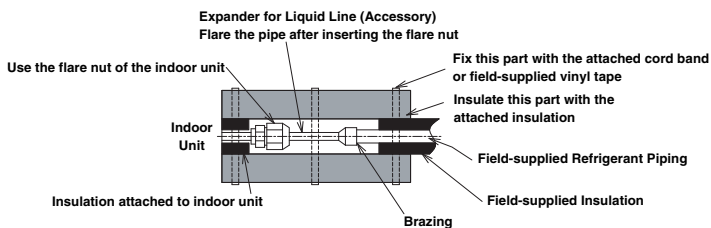

3.4. PIPING CONNECTION

- Use clean copper pipes without any moisture or foreign materials on inner surface of pipes. When connecting refrigerant pipe, cut the copper pipes with a pipe cutter as shown below.

Also blow the pipes with nitrogen or air to remain no dust inside the pipe.

Do NOT use a saw, a grindstone or others which causes a large amount of cutting powder.

