

# AIR TO WATER HEAT PUMP

----- Standard EVI



**Operation, installation & maintenance manual**

**V.201510**

The installation of this unit is to adhere to all local  
Building Codes and Standards

# Index

Nomenclature .....	2
Working principle.....	3
Specialist Tools .....	4
Pre-installation .....	5
Installation Location .....	7
Positioning .....	8
Buffer Tank .....	9
Frost Protection .....	10
System Overview Heating Hot Water Production.....	11
System Overview Heating, Cooling with Hot Water Production with Boiler back up .....	13
System Overview Multiple Units in Series Cascade Connection .....	15
Installation.....	17
Electrical connection.....	18
User Guide .....	24
Service Parameters:.....	39
Service Guide.....	40
Commissioning and Adjusting .....	47
Commissioning Form.....	49
Alarms.....	50
Maintenance .....	56
Dimensions .....	59
Water Pressure Plots.....	60
Temperature and sensor resistance table .....	63
Components .....	65
Technical Specifications.....	66

# Nomenclature

AS10S/L — D6NNNE

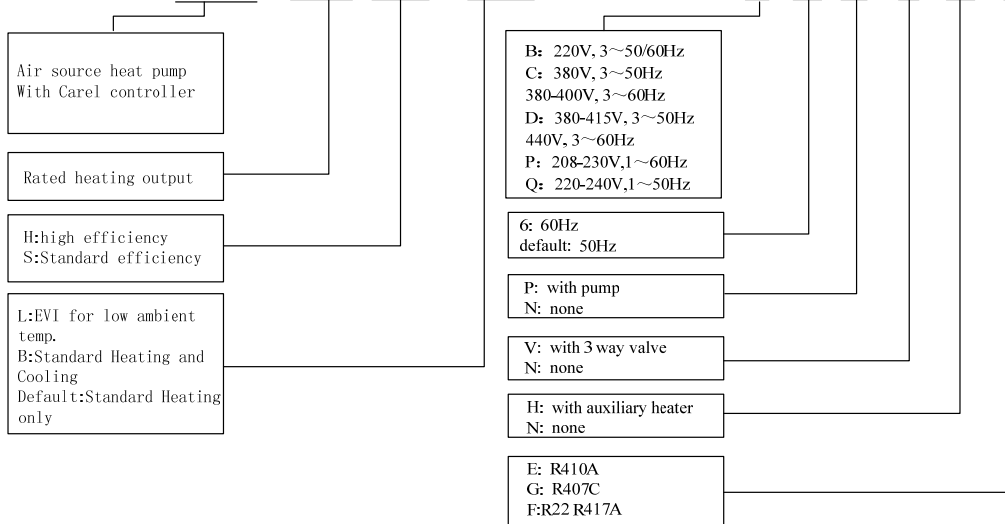

## Working principle

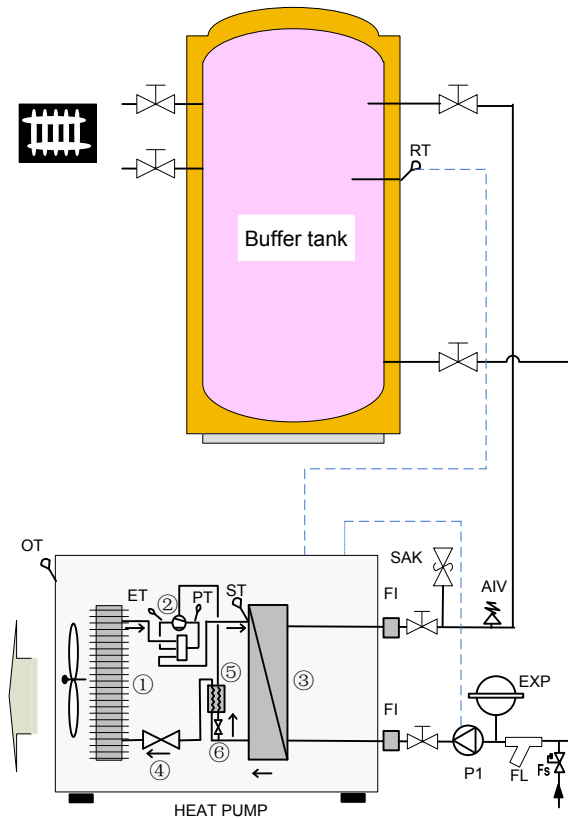

1. The low pressure and low temperature liquid refrigerant coming out of expansion valve exacts heat energy from the air through finned coil heat exchanger ① and evaporates into gas state.
2. The gas state refrigerant is sucked into compressor ② and compressed to high pressure and high temp. gas .
3. The high pressure and high temp. gas discharged by compressor releases its heat energy to water in plate exchanger ③ and condensed to liquid state.
4. The liquid state refrigerant is expanded in thermostatic expansion valve ④ and become low pressure and low temperature liquid refrigerant.
5. The cycle repeats.
6. When EVI condition is met, EVI expansion valve ⑥ will open and some liquid gas will expand and the gas will be inject into compressor middle containment after absorbing heat from main branch liquid gas in the economizer ⑤. With this EVI function, not only heat pump heating capacity and COP will increase ,but also compressor discharge temp. could be controlled within safety limit and the heat pump workable ambient temp. could be extended to  $-25^{\circ}\text{C}$  .

## Specialist Tools

Specialist tools that might be used on installation, commissioning and maintenance.

The tools as exclusive tools for R410A refrigerant.

1 Gauge manifold ·Only for R410A

- Use the existing fitting specifications.(G1/4")
- Use high-tension side pressure of 5.3MPa·G or over.

2 Charge hose ·Only for R410A

- Use pressure performance of 5.09MPa·G or over.

3 Electronic scale

4 Gas leak detector ·Use the detector for R410A.

5. Vacuum pump (pump with reverse flow preventive function)

6 Refrigerant charge base

7 Refrigerant cylinder ·Only for R410A Top of cylinder (Pink)Cylinder with syphon

8 Refrigerant recovery equipment

9. Torque wrench

10. Multi-meter

11. screwdrivers

# Pre-Installation

## Movement and Storage

The unit must not be transported, moved or stored at greater than a 30° angle from the upright position. Store the unit in a dry area until required.

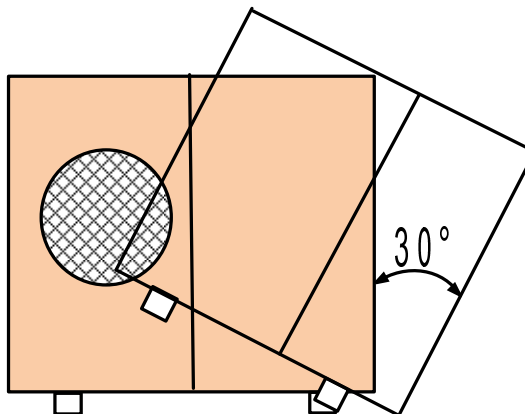

The unit must be installed by a suitably qualified tradesperson and all electrical wiring must be completed by a licensed electrical contractor in accordance with all local Standards.

## Safety

The installation must be overseen by a qualified person, in order to avoid an incorrect installation that could damage to the unit or cause injuries to people. Any faults and or leaks must be repaired immediately before the unit continues to operate. If repairs have been carried out to the unit then operation of the safety devices and parameter must be rechecked.

If a refrigerant leak occurs, remove the complete charge using a recovery unit and store the refrigerant in mobile container.

***Note: care is to be taken as the refrigerant can breakdown due to high temperature, these refrigerants by-products are dangerous.***

Once the leak has been repaired recharge the unit with the correct filling weight and the type found on the unit's nameplate.

***Note: ensure the correct refrigerant gas is used to recharge the unit as an incorrect gas can cause damage beyond repair to the compressor.***

**Do not use oxygen to purge lines or to pressurize a unit for any purpose.** Oxygen gas reacts violently with oil, grease and other common substances. Use only refrigerant or dry nitrogen for testing.

Never exceed the specified maximum operating pressures.

## Pre-Installation

Do not un-weld or flame cut the refrigerant lines including any refrigerant circuit components until the entire refrigerant (liquid and vapour) has been removed from unit. Traces of vapour should be displaced with dry nitrogen.

**Refrigerant in contact with an open flame will produce toxic gases.**

Ensure that the necessary safety protection equipment is available when servicing. Have the appropriate fire extinguishers for that system.

**Do not siphon refrigerant.**

Avoid spilling liquid refrigerant onto the skin or splashing it into the eyes. Use safety goggles. Wash any spills from the skin with soap and water. If liquid refrigerant enters the eyes, immediately and abundantly flush the eyes with water and consult medical advice.

***Note: Never apply an open flame or live stream to a refrigerant container. This can dangerously overpressure and cause an explosion.***

Compressor oil type : 3MA POE

The heating system must be pressure tested and air vented completely.

Filling water and supplemented water must be drinking water quality (colourless, clear, free from sediments)

Filling water and supplemented water must be pre-filtered. (pore size max. 5µm)

## Installation Location

- The unit must be installed on a solid level surface on a concrete pad foundation not connected to the house foundation. Rubber cushions can be added to reduce vibration and noise if required.
- The unit should be placed so that it is well away from bedrooms or noise sensitive areas including neighbour's section boundaries. (The unit will produce noise that is above the minimum 45 decibel rating).
- The unit should be well ventilated with no obstructions and kept level at all times.
- Ensure there is good drainage around installation area and make sure this water cannot run out onto paths as it may cause ice or slime build up which is undesirable. (The unit can produce large volumes of condensation water when running in high humidity zones. There is also a large run off when the unit melts ice during a defrost cycle).
- Avoid locations exposed to machine oil vapour, salty air, thermal springs sulphur gases or other harsh substances
- If operation in temperatures below 0°C for prolonged periods or locations where the snow may fall the unit must be raised at least 300mm off the ground. This is necessary to avoid ice build-up on the unit's chassis.
- The unit must be installed level in both axes (less than 2mm tolerance per meter)
- Locations exposed to strong winds should be avoided otherwise baffles may be necessary to deflect strong winds and to prevent snow from blowing directly into the unit. They must not restrict air flow into the unit.
- Keep suitable distance between the unit and the building to ensure the normal running of the unit and enough room is available for maintenance.



# Positioning

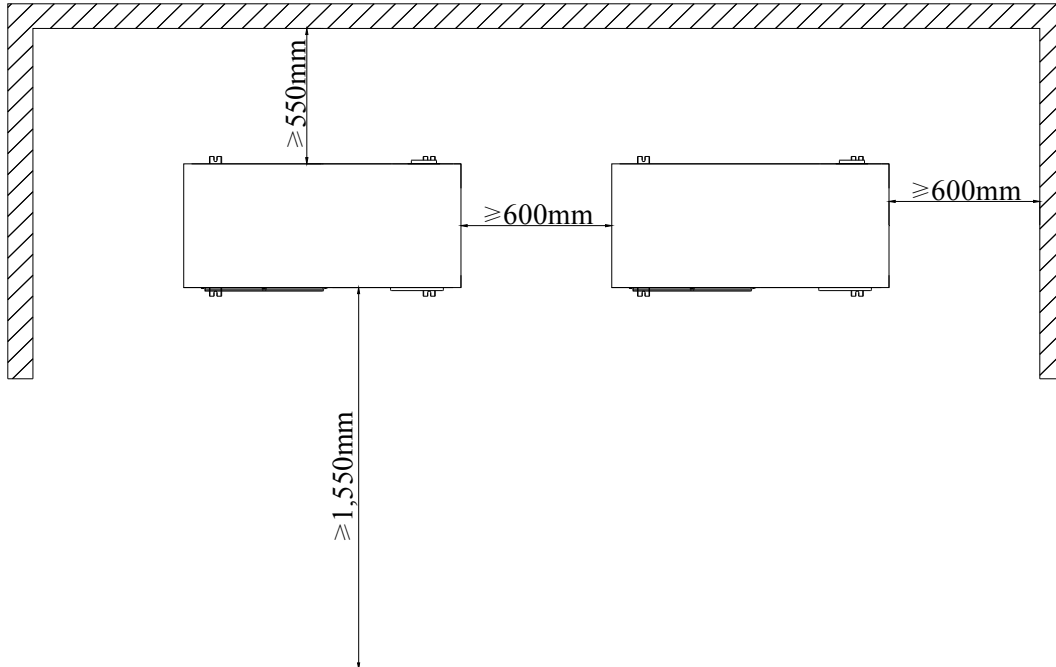

# Buffer Tank

A buffer tank is recommended to ensure a trouble free heat pump operation. A suitable buffer tank can avoid excessive heat pump cycling (switching on and off).

The buffer tank provides a hydraulic separation from the volume flow in the heat pump and heating circuits. The volume flow in the heat pump circuit remains constant, even if the heating circuit volume flow is reduced by thermostatic valves.

If the total of the systems water volume is less than 12L/KW then a buffer tank should be added to reduce the compressor from ON/OFF cycling. This will prolong the compressor life span.

When a buffer tank is installed, the heating system will absorb energy from the buffer tank first. To save energy consumption, install the indoor pump P1 that is switched on only when compressor is on. This is by changing EV01 indoor pump mode to “work by regulation”.

Inlet water temp sensor should be taken out of the unit and put into buffer tank’s sensor pocket. The Inlet water temp sensor is located on inlet water pipe. The Inlet water temperature sensor B1 in the buffer tank will control the tank temperature by starting and stopping the compressor and pump together as required.

If Inlet water temp sensor has not been changed to buffer tank’s sensor pocket when EV01 has been changed to “work by regulation”, when the unit reaches its set temperature, the compressor will stop, pump P1 will also stop accordingly due to EV01 being set to “work by regulation”. When this occurs, there is no water circulation between the heat pump and buffer tank. Inlet water temp will keep its stopped temperature, not the buffer tank water temperature. Inlet water temp sensor B1 then can not switch on compressor and pump P1 even when buffer tank water is getting cold. Changing the Inlet water temp sensor into the buffer tank will avoid this problem.

# Frost Protection

The plate heat exchanger, the piping and the hydraulic pump can be damaged by frost, despite the built-in anti-freeze protection of the unit.

In frost prone areas refer to installation location instructions.

To avoid freezing-up of the water contained in the system, one of the precautions must be taken during winter:

1. Drain the water from the system, using the drains in the lower part of the unit.
2. Add the correct percentage of glycol antifreeze to the water circuit.
3. The power to the unit must be on all the time so unit can start circulation pump and auxiliary heater for anti-freeze protection.

## ***Important***

***The pipe work must be flushed before the heat pump is connected, so that any contaminants do not damage the components parts .***

***The water pressure in the evaporator can not exceed 500 kPa or 72 PSI.***

# Systems Overview

## System Overview Heating Hot Water Production

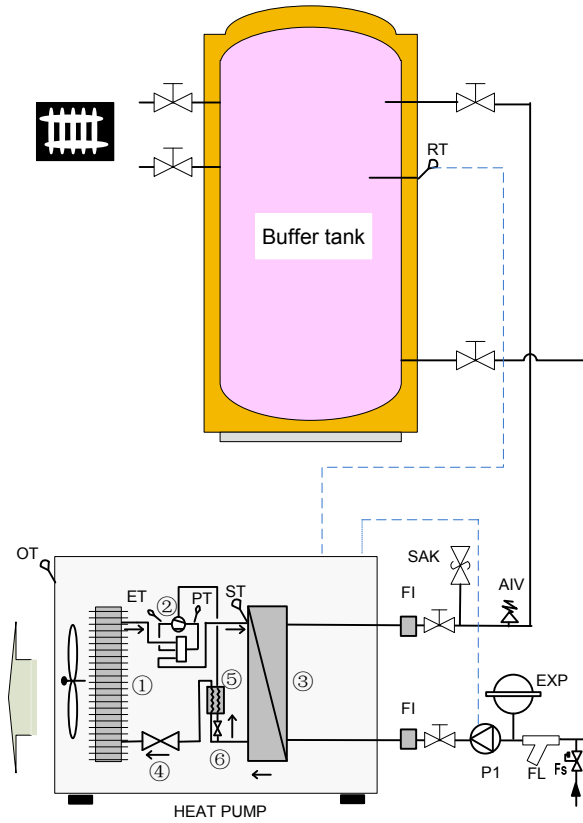

Name	Description	Included	Name	Description	Included
P1	Circulation pump	External	RT	Inlet water temperature sensor	Internal
AIV	Air vent valve	External	ST	Outlet water temperature sensor	Internal
FI	Soft joint	External	OT	Outdoor temperature sensor	Internal
SAK	Safety valve	External	PT	Discharge gas temperature	Internal
FL	Filter	External	ET	Suction gas temperature	Internal
EXP	Diaphragm expansion vessel	External	FS	Automatic water supplement valve	External

# Systems Overview

## Heating Mode Working Principle:

On heating mode

a. When SF04:enable compensation=NO,  
When the Inlet water temperature  $\leq$  RTc-ST04 (RTc is the actual Inlet water temperature of the last stop) ,the compressor will start to heat. After outlet water temp.  $B2 \geq$  ST02, compressor will stop. The Compressor will start again when Inlet water temperature  $\leq$  RTc-ST04,.

b. When SF04 enable compensation=YES,  
ST02 is replaced by “Set temperature at heating” =ST05+ST06/10 \*(ST05-OT).  
Refer to chapter “Heating compensation curve setting” .

# Systems Overview

## System Overview Heating, Cooling with Hot Water Production with Boiler back up

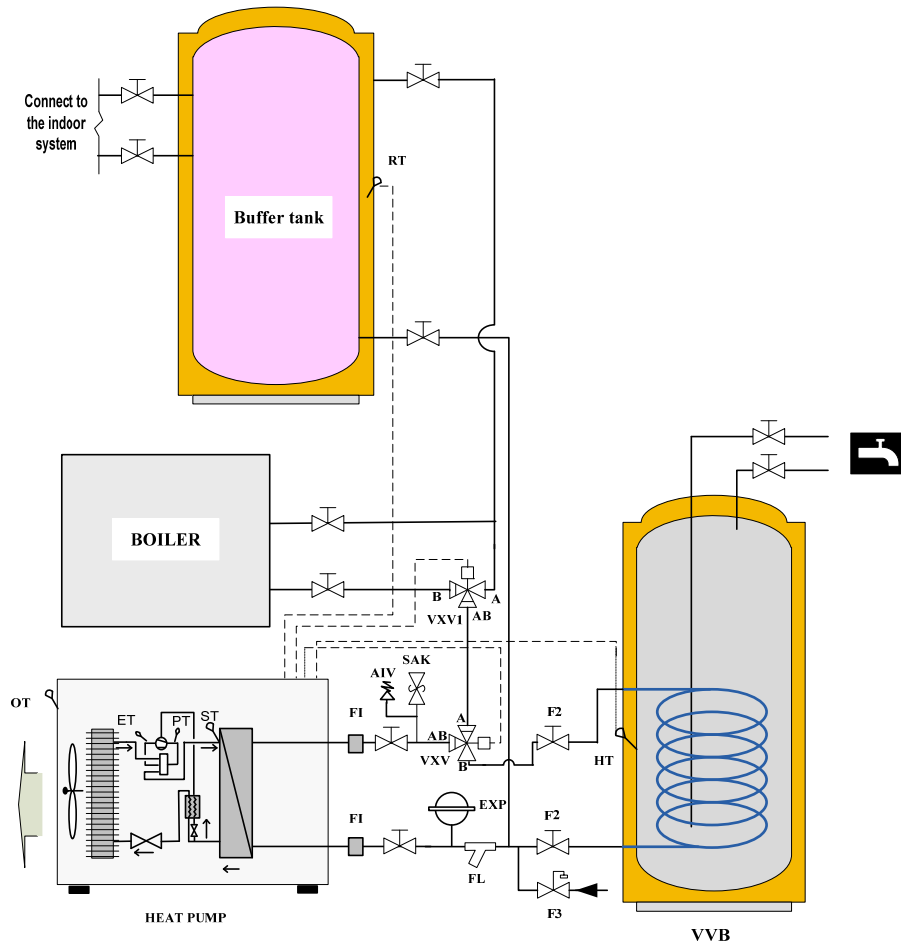

Name	Description	Included	Name	Description	Included
P1	Circulation pump	Internal (optional)	RT	Inlet water temperature sensor	Internal
VXV	3 way valve	External	ST	Outlet water temperature sensor	Internal
VVB	Hot water tank	External	OT	Outdoor temperature sensor	Internal
FI	Soft joint	External	HT	Hot water temperature	Internal
F2	Shut-off valve	External	PT	Discharge gas temperature	Internal
SAK	Safety valve	External	ET	Suction gas temperature	Internal
FL	Filter	External	FS	Automatic water supplement valve	External
AIV	Air vent valve	External	EXP	Diaphragm expansion vessel	External

# Systems Overview

## 1. Heating Mode Working Principle:

On heating mode, Three way valve (VXV) will open AB-A.

1.) When SF04 enable compensation=NO:

- a. When the inlet water temp.  $B1 \leq RTc-ST04$ , (RTc is the actual measured inlet water temp. of last stop) the compressor will start to heat .After outlet water temp.  $B2 \geq ST02$ , compressor will stop. The Compressor will start again when inlet water temp.  $B1 \leq RTc-ST04$ .
- b. When the outdoor temperature Ambient temp.  $B3 \leq ST07$  ,compressor has run over 300s and Outlet water temperature  $B2 \leq ST02-ST04-1$ , the electric heater (ELK) will be activated as heating booster. It will stop heating when Outlet water temperature  $B2 \geq ST02-ST04$ .

2.) When SF04 enable compensation=YES:

ST02 is replaced by “Set temperature at heating” = $ST05+ST06 *(ST05-OT)$ . Refer to chapter “Heating compensation curve setting” .

## 2. Cooling Mode Working Principle:

On cooling mode, Three way valve (VXV) will open AB-A.

When the Inlet water temperature  $B1 \geq RTc+ST03$  (RTc is the actual measured inlet water temp. of last stop), the compressor will start to cool until Outlet water temperature  $B2 \leq ST01$ . Then compressor will stop. The Compressor will start again when Inlet water temperature  $B1 \geq RTc+ST3$ .

## 3. Hot water production working principle:

On hot water mode, Three way valve (VXV) will open AB-B.

When domestic hot water requirement calls, the three way revert valve (VXV) will have the priority to revert to the hot water tank (VVB). After the domestic hot water reach its set temperature ST09, the three way revert valve (VXV) return to its heating position. After Hot water temp.  $B4 \leq ST09 - ST10$ , three way revert valve (VXV) will revert to hot water circuit again.

# Systems Overview

## System Overview Multiple Units in Series Cascade Connection

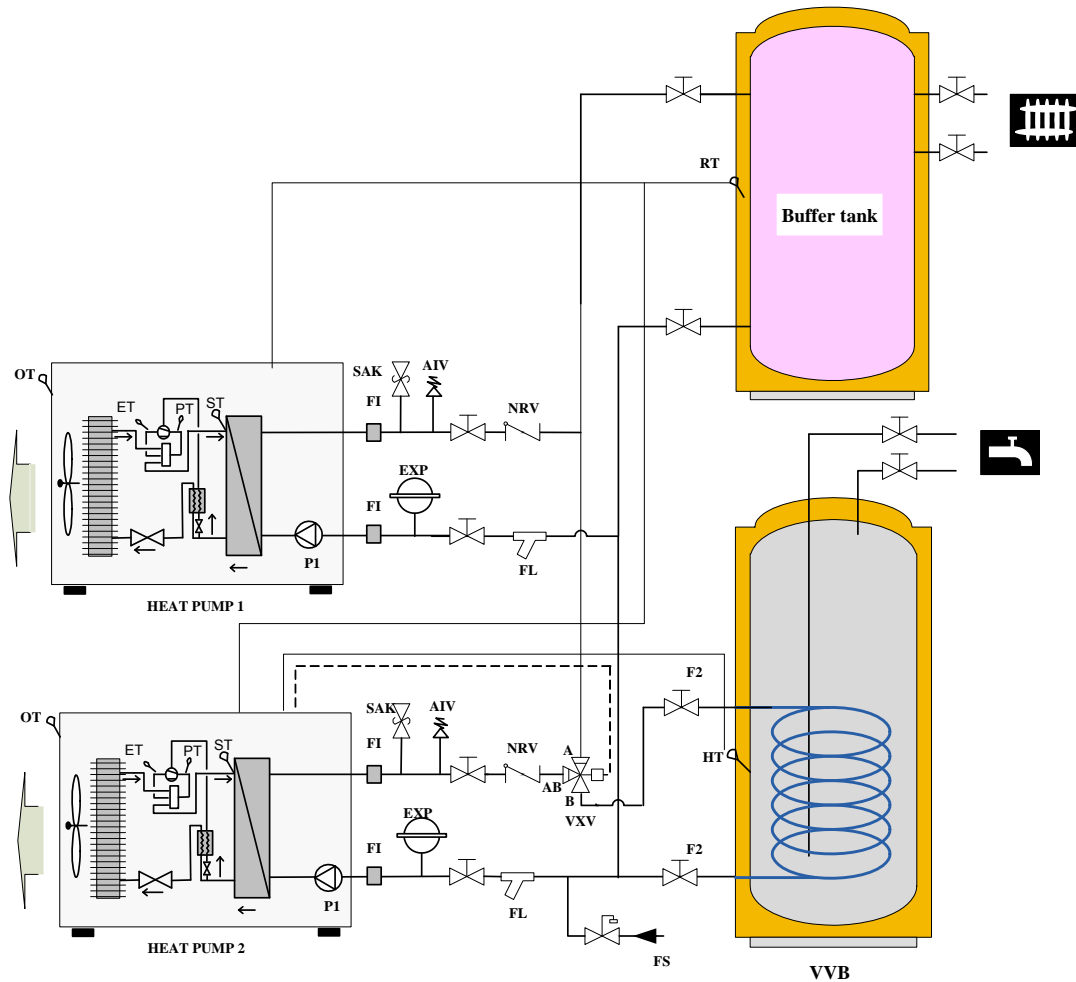

Name	Description	Included ?	Name	Description	Included ?
P1	Circulation pump	Internal(Optional)	RT	Inlet water temperature sensor	Internal
VXV	3 way Valve	External	ST	Outlet water temperature sensor	Internal
VVB	Hot water tank	External	OT	Outdoor temperature sensor	Internal
FI	Soft joint	External	HT	Hot water temperature sensor	Internal
F2	Shut-off valve	External	PT	Discharge gas temperature	Internal
SAK	Safety valve	External	ET	Suction gas temperature	Internal
FL	Filter	External	EXP	Diaphragm expansion vessel	External
NRV	Non return valve	External	FS	Automatic water supplement valve	External
ELK	Electric heater	Internal(Optional)	AIV	Air vent valve	External



# Systems Overview

## Multiple Units in Series Connection

### (1) Heating working principle

To set two or more units in parallel operation, set the primary unit to the required parameters, other units could have 2~5°C difference of ST01, ST02 and ST05 to allow for energy stage control.

#### 1. When SF04:ENABLE COMPENSATION=NO:

a). if there is a heating demand, then the unit will start to heat. The unit with the lower ST02 will stop first, the others will stop if their outlet water temp. B2 continue to rise and reach its pre-set ST02.

b). Inlet water temperature B1 will drop when units stop. The unit with the higher RTc-ST04 will start first again to heat . If this unit can meet the heating capacity then its Outlet water temperature B2 will not drop any further, only this unit will run as required. If the heating load is bigger than the capacity of one unit then the inlet water temperature B1 will continue to drop to below the second unit RTc-ST04 , the second unit will be switched on and start increasing the heating capacity.

#### 2. When SF04:ENABLE COMPENSATION=YES:

ST02 is replaced by “Set temperature at heating” =ST05+ST06 \*(ST05-OT). Refer to chapter “Heating compensation curve setting” .

### (2) Hot water production working principle:

On hot water mode, Three way valve (VXV) will open AB-B.

When domestic hot water requirement calls, the three way revert valve ( VXV) will have the priority to revert to the hot water tank (VVB ). After the domestic hot water reach its set temperature ST09, the three way revert valve ( VXV) return to heating circuit position. After hot water temp.  $B4 < ST09 - ST10$ , three way revert valve (VXV) will revert to hot water circuit again.

# Installation

1. The pipe installation must adhere to the local Building Code, standards and any local council requirements.
2. Ensure that the water flow and returns are correct and not reversed. Reversing the water flow will reduce the output of the unit; refer to the labels on the unit for the correct water flow direction.
3. The water pipes must not transmit any radial or axial forces to the heat exchanger. Allow some pipe flexibility between the unit and the structure to reduce any stresses and vibrations issues.
4. The water supplied to the system must be clean and not contain heavy metals that could cause harm to the unit. The water must be treated with an approved inhibitor and tested annually to prevent corrosion, fouling and deterioration of the pump fittings.
5. Protection devices are to be installed to protect the unit from operating outside of its running parameter such as control devices; shutoff valve, bleed valves, safety valves and expansion tanks.
6. The pipe installation should be designed to have the least number of elbows and joiners as they reduce flow. Install drain connections at low points to allow the system to be drain if required.
7. Flexible connections should be used where possible to reduce vibration transmission.
8. Insulate all pipe work and exposed areas to protect against both thermal heat loss and to prevent condensation on chilled pipes.
9. When filling the water system, use air vents and flushing procedure to evacuate any residual air pockets.
10. The heat pump is not fitted with shutoff valves and therefore these must be fitted outside of the heat pump to facilitate future service requirement.

# Electrical Connections

## Power Connection

Before connecting the power supply, please confirm the unit suits the power supply.

- Breaker protection must be installed according to the max value stated in the nameplate attached to the unit inside of the front panel.
- The equipment must be installed via an isolator switch with a minimum breaking gap of 3 mm.
- The power supply must conform to the specification on the unit's nameplate. The supply voltage must be within the range specified in the electrical data table. For wiring connection, refer to the electric wiring diagram on the inside panel of the unit.
- When the building is equipped with a RCD the heat pump should be equipped with a separate one.

### IMPORTANT:

During the installation of the unit, first make the water connections and then electrical connections. If the unit is to be removed first disconnect the electrical connections, then the water connections to reduce the chance of an electrical shock.

### WARNING:

Disconnect the main power supply switch before servicing the system or handling any internal parts of the unit.

In case of any major malfunction turn the unit off, disconnect the mains power supply and contact a qualified service engineer.

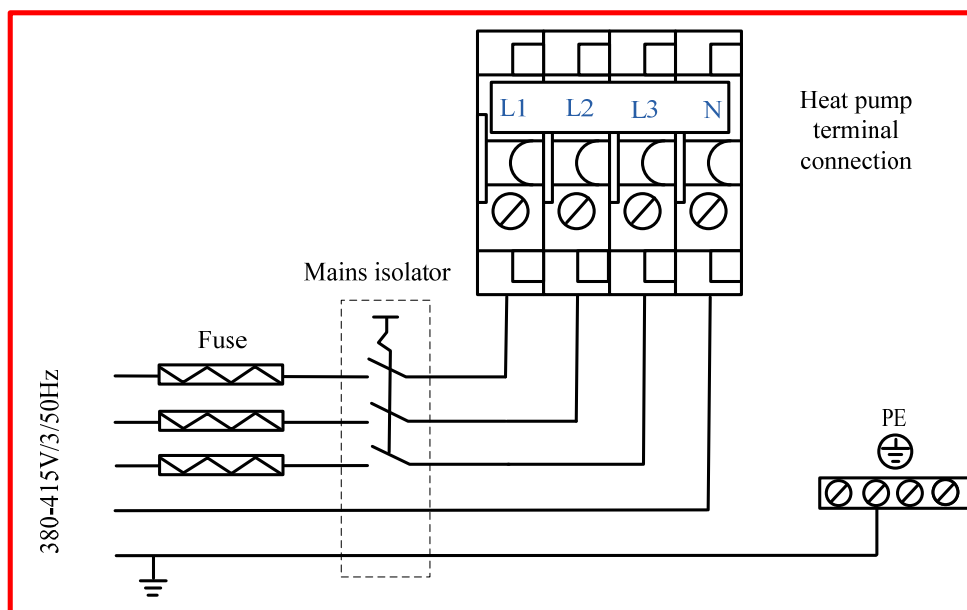

# Electrical Connections

## **Outdoor Ambient Temperature Sensor:**

The outdoor temperature sensor (B3) is a standard component and is prewired and positioned in the unit. The probe is located at the back of the unit in a protective casing. The outdoor sensor is terminated on the PC board B3 and GND.

## **Temperature sensor for hot water:**

The hot water sensor (B4) is connected to terminal positions B4 and GND on the main board, the other terminal must be put into hot water cylinder temperature sensor probe inlet pocket if required.

If the hot water sensor cable runs close to power cables, then a shielded cable should be used. If a conduit is used then it should be sealed to avoid condensation forming in the temperature sensor probe.

## **Indoor Side Inlet Water Temperature Sensor:**

The indoor side inlet water sensor (B1) from factory is placed at inlet water pipe.

If a buffer tank is installed, the Inlet water temperature sensor B1 can be moved to the buffer tank temperature sensor inlet pocket and EV01 parameter value can be set to “work by regulation”. This stops the pump running when compressor is OFF.

If the Inlet water temperature sensor B1 can not be moved to the buffer tank temperature sensor inlet, the EV01 parameter value must be set to “continuous work” (factory default setting). This allows the pump to continue to run so Inlet water temperature sensor B1 measured the same as buffer tank water temperature.

### ***Important:***

*All temperature sensor must be separated (min 200 mm) from high voltage power cables to avoid interference which will cause measured temperature fluctuating and the heat pump may operate incorrectly.*

# Electrical Connections

The unit has two ways to turn ON/OFF heating functions.

SF14: A/C On/Off way 1.) remote 2.) keyboard

## A/C Switch:

SF14 set to “keyboard”(factory default setting). Then the A/C switch could not control the unit any more, wired remote control will take over control the unit .

If SF14 set = “remote”. Keyboard can not be used to turn On/Off the heating and no heating timezone On/Off function.

B1-B2 switch is activated to turn On/Off the unit.

When the A/C switch B1-B2 is bridged, the unit’s heating function is activated. An external signal like a timer or thermostat, etc could be connected to B1-B2 to activate or deactivate the unit’s heating function. This external signal must be voltage free.

Case 1 : Install a manual switch inside the house to switch on/off heating.

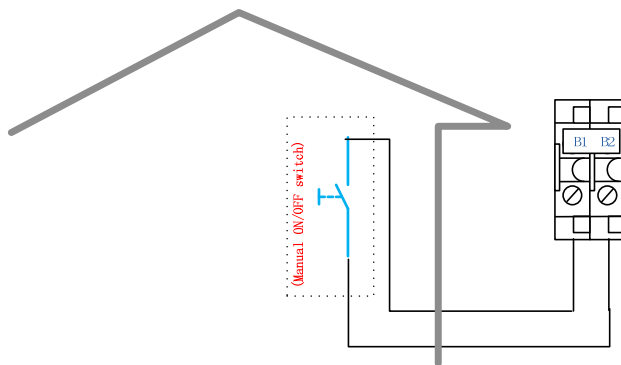

Case 2: Install a timer switch inside the house to switch on/off heating automatically

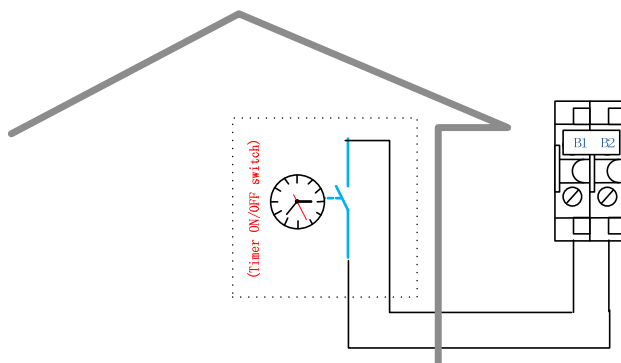

### *Note*

***This is a potential free input contact only. DO NOT PUT 230VAC INTO THIS CONTACT***

# Electrical Connections

The unit has two ways to turn ON/OFF domestic hot water functions.  
SF13: HW On/Off way 1.) remote 2.) keyboard

## Hot Water Switch:

When SF13 set= “remote”, Keyboard can not be used to turn On/Off the DHW and no DHW timezone On/Off function.

A1-A2 switch is activated to turn On/Off the hot water function.

hot water switch A1-A2 is bridged, the unit’s hot water function is activated.  
An external signal like a timer or thermostat, etc could be connected to A1-A2 to activate or deactivate the unit’s hot water function. This external signal must be voltage free.

Case 1 : Install a manual switch inside the house to switch on/off hot water production

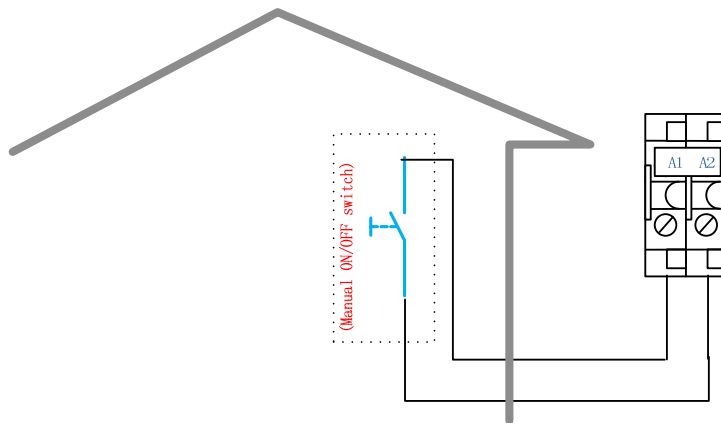

Case 2: Install a timer switch inside the house to switch on/off hot water production automatically

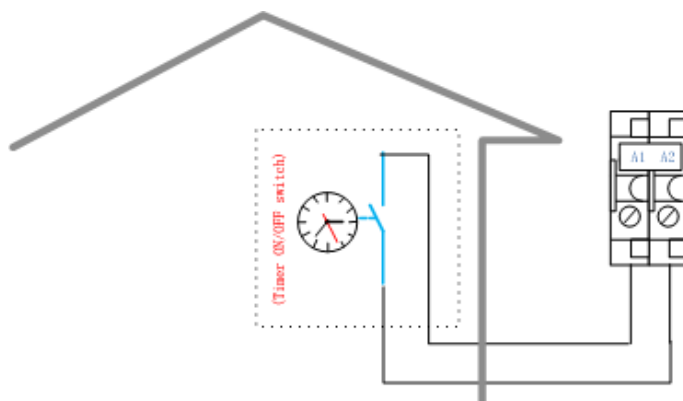

### Note

***This is a potential free input contact only. DO NOT PUT 230VAC INTO THIS CONTACT***

# Electrical Connections

## External Water Pump Connection (N02)

There is a connection port (1-2) at the terminal block for connecting circulation water pump..

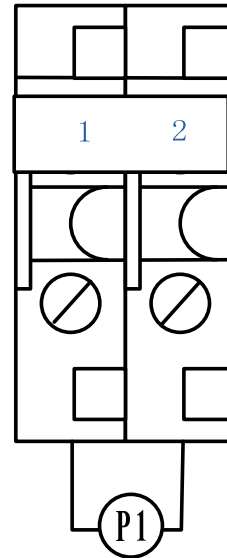

If PWM pump is adopted, PWM signal is connected to D1-D2

## Three Way Valve Connection (NO7 NC7)

A 3 way valve could be connected to terminal (7-8-9) for domestic hot water production.

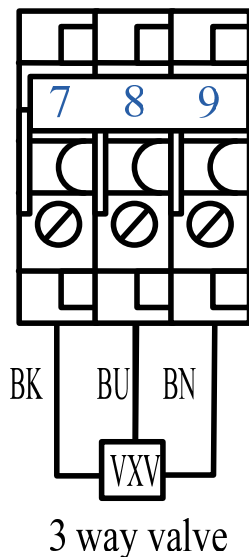

# Electrical Connections

## Auxiliary Heating Electric Heater or Boiler (NO4)

There is a connection port (10-11) which can be used to activate and de-activate an auxiliary electric heater or a boiler. The max current is 1 Amps therefore a contactor must be applied to control auxiliary electric heater or boiler.

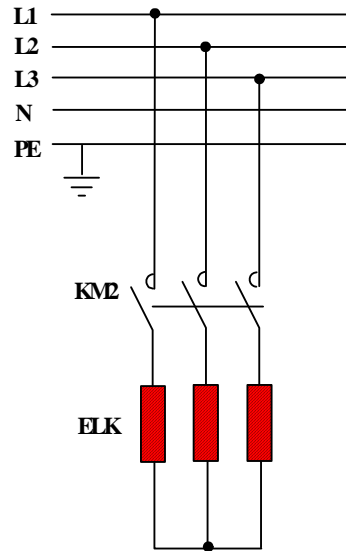
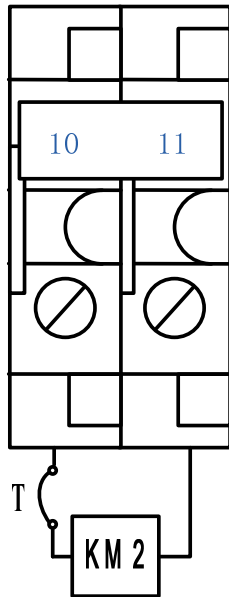

## Hot Water Electric Heater (NO8)

There is a connection port (12-13) used to activate and de-activate hot water electric heater. The max current is 1 Amps therefore a contactor must be applied to control hot water electric heater. User parameter ST26 is the hours in interval to switch on hot water heater to kill bacterial. After hot water temp. reaches ST27 pre-set water temp., hot water heater is switched off.

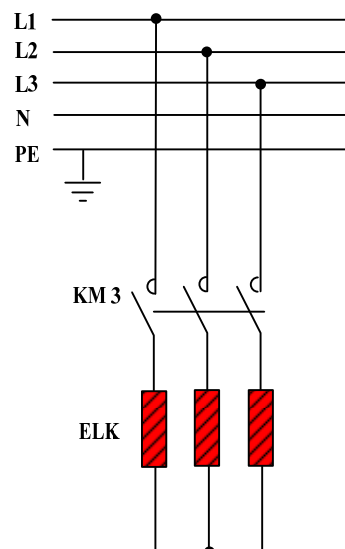
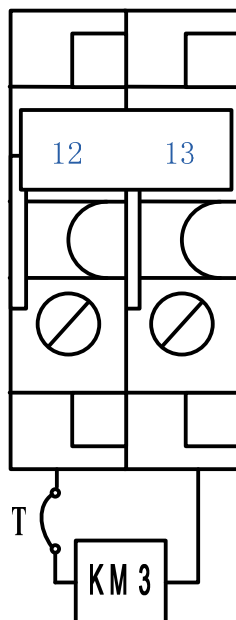



# User Guide

## User interface

Find the user interface and connection cable from compressor room .



Standard factory delivered connection cable is 10m.

User interface should be installed indoor. It could be installed about 1.5m up from the floor ,out of reach of children.

Connect the user interface with the control board via the connection cable.

## User interface (Display window & button area)

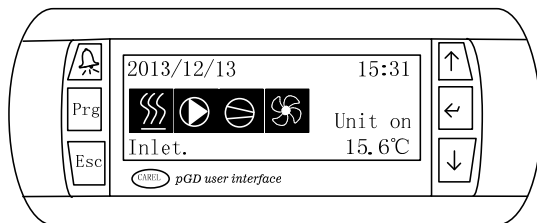

## Operating buttons

Button	Name	Operation
	<Alarm>	It will flash to indicate when any alarm happens. Press it to re-set manual re-set alarms after the fault is removed.
	<Program>	Press it to enter main menu
	<Esc>	In Menu /parameter setting mode, press it to return to the previous menu level.
	<Enter>	In Menu/parameter setting mode, press it enter the menu , or the value entered or scroll to next parameter data.
	<Up>	Press it to scroll to another menu or to increase the value in Menu/parameter setting mode
	<Down>	Press it to scroll to another menu or to decrease the value in Menu/parameter setting mode On stop, standby or On mode, press it to read actual temp. from inlet water temp. to outlet water temp.....

# User Guide

## Symbol explanation

	Heating mode
	Cooling mode
	Domestic hot water mode
	Domestic hot water mode + Heating mode
	Domestic hot water mode + Cooling mode
	Water pump
	Compressor
	Fan

## Menu Tree

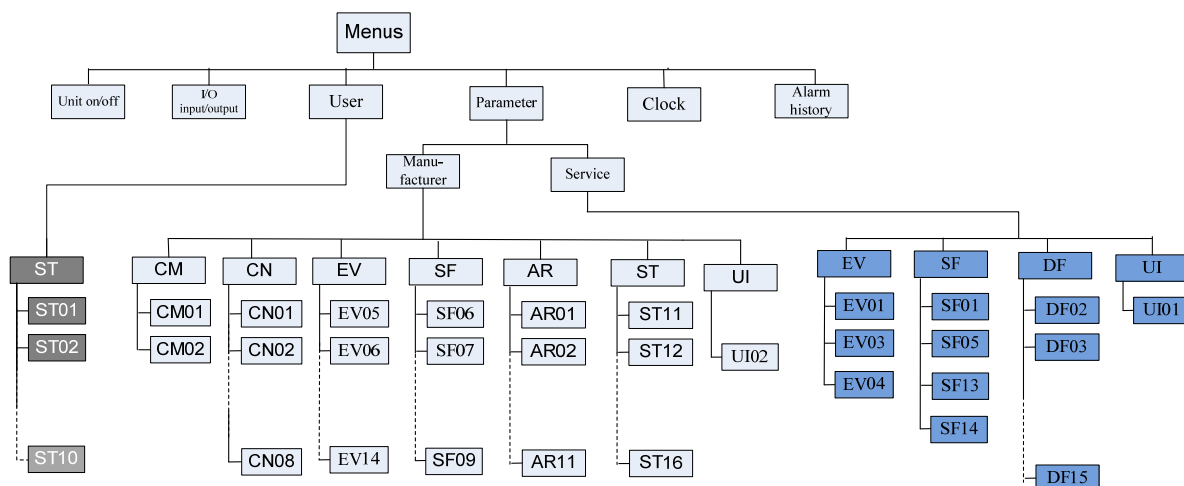

Code	Indication	Code	Indication
CM	Compressor settings	ST	Setpoints
CN	Condenser settings	UI	User interface
EV	Evaporator settings	AR	Alarm settings
SF	Special functions	DF	Defrost settings

# User Guide

## Access Rights

Three groups of users with different privilege levels are described below.

Privilege Level	Main Activities <i>Special</i>	All
Manufacturer	<ul style="list-style-type: none"> <li>• Password required</li> <li>• Configure and commission applications by setting/adjusting parameter values</li> </ul>	<ul style="list-style-type: none"> <li>• View information and status</li> <li>• Acknowledge warnings and alarms</li> <li>• Heating /Cooling changeover</li> </ul>
Service	<ul style="list-style-type: none"> <li>• Password required</li> <li>• Configure and commission applications by setting/adjusting parameter values</li> </ul>	
User	<ul style="list-style-type: none"> <li>• No password is required</li> <li>• Adjust limited values of parameters</li> </ul>	

## Main menu:

Press  button to enter main menus:

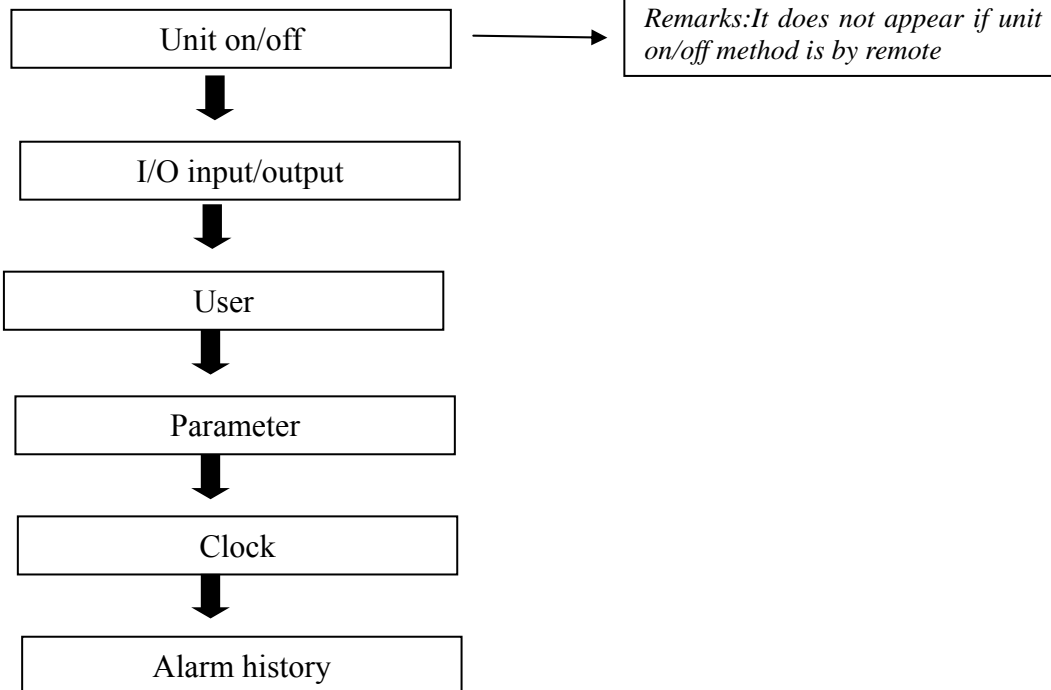

## Unit on/off (when unit on/off way setting is keyboard)

Press  button, it display

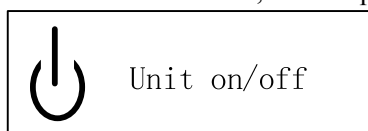

# User Guide

Press  button, it display the unit current air conditioning (AC) and domestic hot water (HW) On/Off status. If the pre-set mode is heating, it display AC status(heat).

Unit on/off	
AC status(heat) :	OFF
HW status:	OFF

Black cursor flashes on “OFF” on AC status(heat) , press  button, it display

Unit on/off	
AC status(heat) :	OFF
HW status:	OFF
Sure to switch on?	

Press  button to enter. It displays:

Unit on/off	
AC status(heat) :	ON
HW status:	OFF

Press  button, black cursor flashes on “OFF” on HW status , press  button, it display

Unit on/off	
AC status(heat) :	ON
HW status:	OFF
Sure to switch on?	

press  button to enter, it will display

Unit on/off	
AC status(heat) :	ON
HW status:	ON

Unit A/C and DHW are successfully switched on. “Starting “ displays on screen ,water pump turns on and display pump symbol on screen, with some minutes’ delay, fan and compressor will turn on and display the symbol on screen.

Inlet ,outlet, ambient temperature ,etc could be checked via pressing up and down button .

Switching the unit Off is same operation.

The units also could be switched on/off via digital switch A1-A2, B1-B2, referring to chapter Electric connection – A/C switch & hot water switch

# User Guide

## I/O input/output

This menu display the unit measured temperature sensors value , digital switch on/off state, components on/off state.

B1	RT	AC inlet temp
B2	ST	AC outlet temp.
B3	OT	Ambient temp.
B4	HT	Hot water temp.
B5	PT	Discharge temp.
B6	ET	Suction temp.
B11	LPS	Suction pressure and temp.
B12	HPS	Discharge pressure and temp.
DI1		AC flow switch
DI2		No use
DI3		No use
DI4		AC switch
DI5		DHW switch
DI6		Power fault
DI7		Comp. OL
NO1		Compressor
NO2		Water pump
NO3		4-way valve
NO4		AC heater
NO5		Crankcase heater
NO6		Inject valve
NO7		3-way valve
NO8		How water heater
NO9		De-icing heater
Y1		EC fan
Y3		Water pump PWM

# User Guide

## Change System mode

Button Operation: Prg → User → System mode

System mode only could be changed on heating/cooling unit (SF01 unit type setting cooling + heating).

When unit is off state, press “Prg” to main menu, press up or down button to User, press Enter button to enter, it display

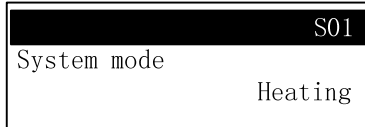

Press Enter button, Heating will flash, press up or down button to change to Cooling, Press Enter button to confirm.

It will display:

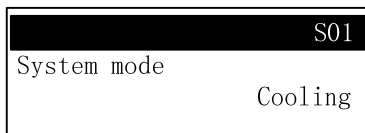

## Changing Set points (for user)

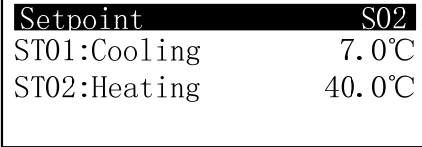
Display	Procedures
 <p>User</p>	<p>press &lt;Prg&gt; to main menu, press Down button to User, Press Enter button, Press Down button to the desired parameter.</p>
	<p>Press Enter button, when 7.0 is flashing, press Up or Down button to change the value.            Press Enter to confirm.            Cursor will move to next parameter data 40, 40 will flash and could be changed via up or down button.            Press Enter to confirm,            Cursor will move to setpoint,            When setpoint is flashing, press Down button to next parameters.</p>
<p>Or, continuously press &lt;Esc&gt; to exit out of the current level and back to the desired menu level.</p>	

# User Guide

## User Parameters

Parameter	Descriptions	De-fault	Min.	Max.	Unit	Res
System mode	Cooling or heating					
ST01	Setting temperature at cooling mode	7	ST11	ST12	°C	0.1
ST02	Setting temperature at heating mode	40	ST13	ST14	°C	0.1
ST03	Setting temperature difference at cooling mode	2	0	10	°C	0.1
ST04	Setting temperature difference at Heating mode	2	0	10	°C	0.1
ST05	Setting temperature at heating compensation	25	0	30	°C	0.1
ST06	Compensation factor for heating compensation	0.6	0	30	-	0.1
ST07	Outdoor temp. to start the boiler or electric heater	0	-20	20	°C	0.1
ST09	Hot water temperature	50	ST15	ST16	°C	0.1
ST10	Hot water temperature difference	3	1	10	°C	0.1
ST26	Disinfect time	0	0	1000	h	1
ST27	Disinfect temperature	65	50	99.9	°C	0.1
TR09	AC timezone On/Off	NO	YES or NO			
TR10	HW timezone On/Off	NO	YES or NO			
SF04	Enable weather compensation	NO	YES or NO			

User parameters could be adjusted when the unit is ON or OFF.

# User Guide

## Heating compensation curve setting

The control temperature for heating mode has two methods: fixed and changeable temperature. The fixed temperature is a fixed value and directly set by the user from the set area. The changeable temperature is determined by values of ST05, ST06 and the actual outdoor temperature measured by the OT sensor probe.

This function is selected by SF04:

when SF04:ENABLE COMPENSATION=NO, it is fixed temperature;

when SF04:ENABLE COMPENSATION=YES, it is changeable temperature.

When SF04:ENABLE COMPENSATION=NO, the set temperature at heating is ST02;

When SF04:ENABLE COMPENSATION=YES, the set temperature at heating will be controlled by ambient temperature (OT), ST05 and ST06 according to the following formula:

Set temperature at heating =  $ST05 + ST06 * (ST05 - OT)$ .

- ST05 is indoor temperature that the user feel comfortable
- ST06 is the heating compensation coefficient curve factor you select for the heat pump to work with. Increasing ST06 will increase compensation temperature and RT will increase relatively.
- OT is the outside temperature.

The calculated temperature can be used for the control reference, but the maximum data will not exceed ST14

For example:

Set the heating compensation coefficient  $ST06 = 0.7$ ,  $ST05 = 20$

When outdoor temperature is  $0^{\circ}\text{C}$ , the control temperature is

$ST05 + ST06 * (ST05 - OT) = 20 + 0.7 * (20 - 0) = 34^{\circ}\text{C}$ ;

When outdoor temperature is  $-10^{\circ}\text{C}$ , the control temperature is

$ST05 + ST06 * (ST05 - OT) = 20 + 0.7 * (20 - (-10)) = 41^{\circ}\text{C}$ ;

When outdoor temperature is  $-20^{\circ}\text{C}$ , the control temperature is

$ST05 + ST06 * (ST05 - OT) = 20 + 0.7 * (20 - (-20)) = 48^{\circ}\text{C}$ ;

User does not need to calculate it .Just check from below curves.

There are three curves with ST05 from 18 to 22 and ST06 from 0.3 to 2.

Calculated result as above can not check from curve below.

### Heating curve $ST05 = 20^{\circ}\text{C}$

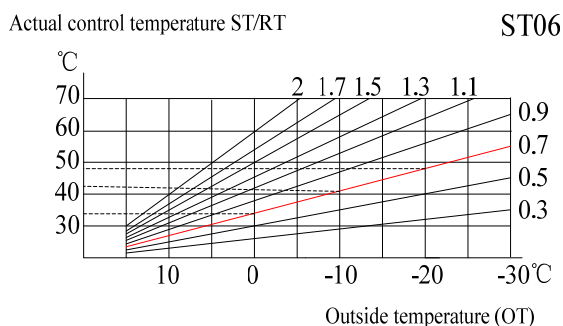



# User Guide

With the drop of the outdoor temperature, the control temperature become higher and higher to meet the large heating requirement.

With the increase of the outdoor temperature, the control temperature become lower and lower, so that the heat pump works under low pressure to keep low energy consumption.

Changing ST05 or ST06 could change the heating curve .

## Increase ST05 will lift up the curve

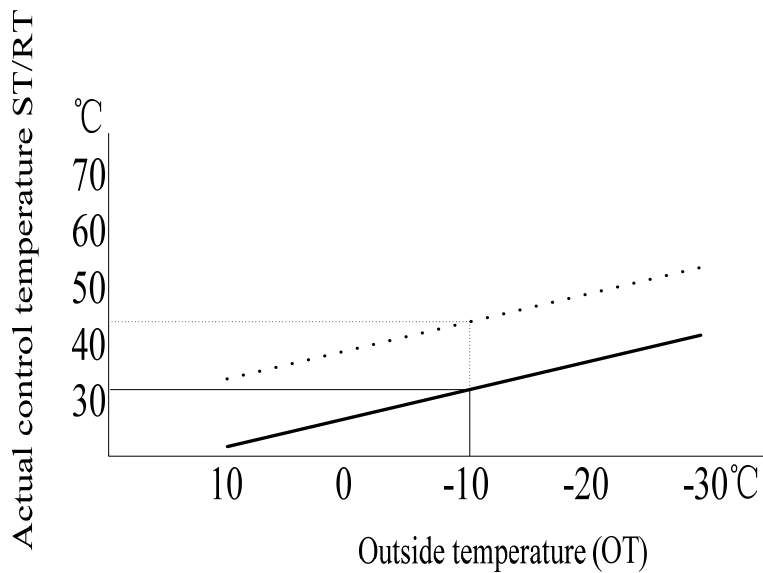

## Increase ST06 will increase the grade of the curve

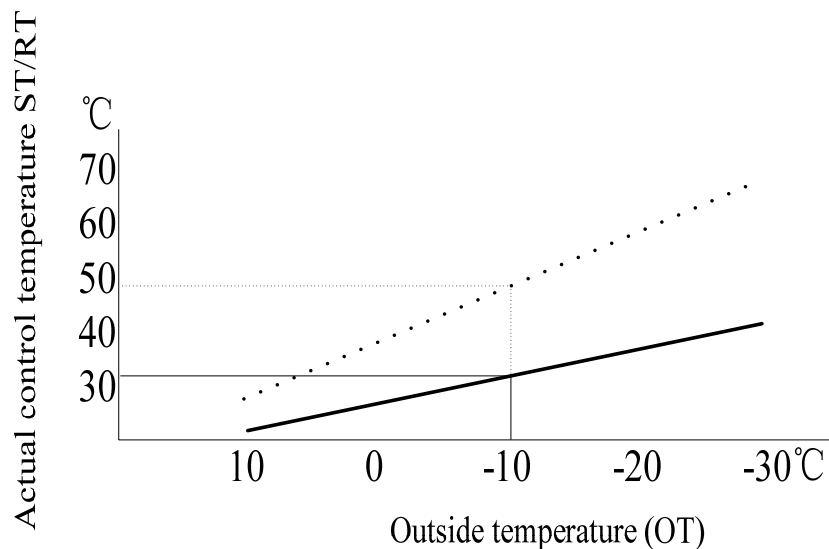

# User Guide

The calculated control water temperature will not be over ST14 Maximum heating temperature and will not be lower than ST13 Minimum heating temperature

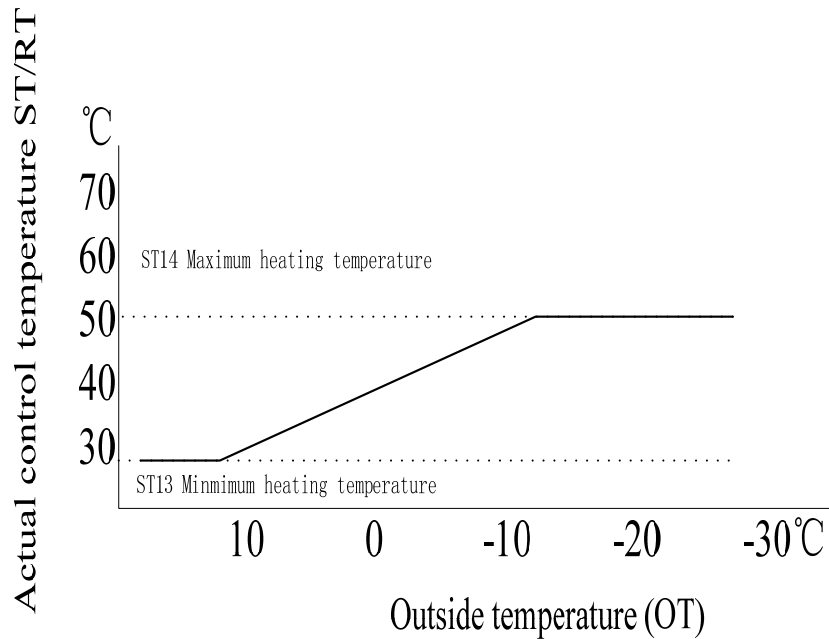

## Cold weather conditions

- When the room temperature is too low, You could increase ST06 .
- When the room temperature is too high, you could decrease ST06.

## Warm weather conditions

- If the room temperature is too low, You could increase ST05 .
- If the room temperature is too high, you could decrease ST05.

*The temp. of the room with floor heating need a long time to stabilize .After a ST05 ST06 adjustment, Pls wait 24 hours before you take another adjustment again.*

# User Guide

Three curves of different ST05 setting:

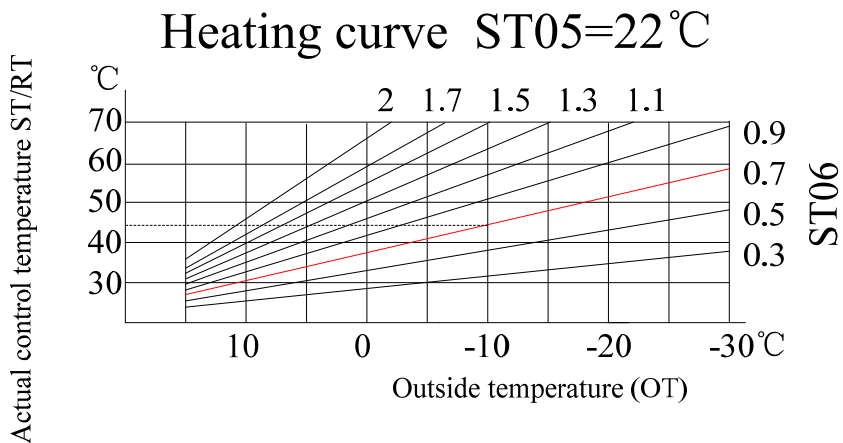
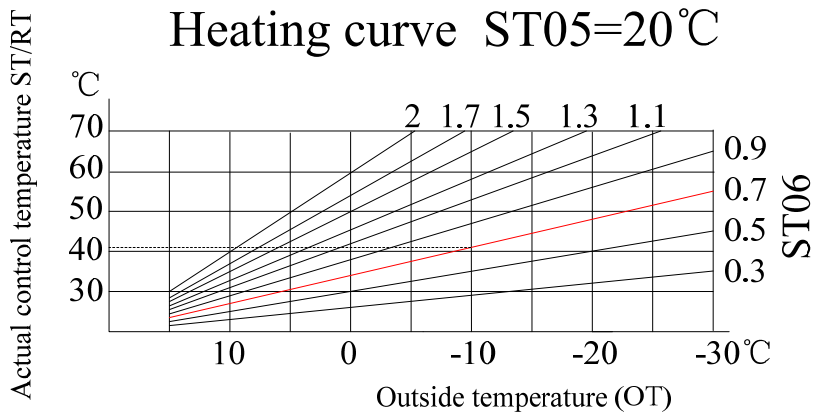
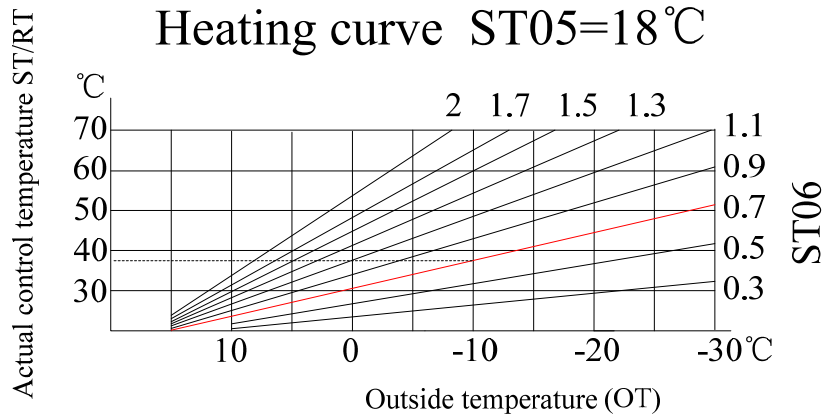



# User Guide

If SF04: Enable compensation =Yes,

S10 menu is popped up :

S10	
ST05=25.0°C	ST06=0.6
OT:	-09.3°C
Actual setp.:	45.6°C

Press  to change ST05 and ST06, OT is actual measured ambient temp. Actual control temp. ST will be displayed.

Press  to menu S11:

S11	
ST05=25.0°C	ST06=0.6
OT:	00.0°C
Heat setp. =	40.0°C

You could input any OT value ,press  and relative heating control temp. will be calculated.

If OT=-15.0°C, actual control temp. is 49.0°C

S11	
OT:	-15.0°C
Heat setp. =	49.0°C

If you have your own curve as below, you want to have ST =38°C when OT=0°C and ST=49°C when OT=-10°C

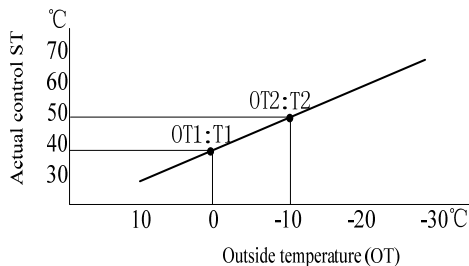

Just adjust wanted T1,T2,OT1 and OT2 in S12 menu and it could help to find out relative ST05 and ST06 setting for desired control outlet water temp in certain OT.

S12	
T1: 38°C	OT1: 00.0°C
T2: 49°C	OT2: -10.0°C
ST05=18.1	ST06=1.1

As above example, ST05=18.1 ST06=1.1 ,then go to menu S10 to input checked result into ST05 and ST06 parameter and you will get the desired weather compensation setting .

# User Guide

## Timezone on/off

Timezone on/off		
TR09:	AC timezone	No
TR10:	HW timezone	No

Timezone activates the pre-set timer programs. Timezone function is only valid when unit ON/OFF method is “by keyboard”.

TR09:AC timerzone is for space heating

When TR09 is set YES, two different time periods is available to set in every day from Sunday to Saturday.

Timezone on/off		
Monday:	ON	OFF
AC-1:	00:00	00:00
AC-2:	00:00	00:00

After finishing timer setting for Monday , then scroll to “Monday” and press up or down button to change to Tuesday to set its timer , then Wednesday and so on. If ON and OFF data is same, the timer function is not activated.

TR10:HW timezone is for domestic hot water.

When TR10 is set YES, two different time periods is available to set in every day from Sunday to Saturday

Timezone on/off		
Monday:	ON	OFF
HW-1:	00:00	00:00
HW-2:	00:00	00:00

If the unit is manually turned on by keyboard before the automatic turning on by the timer, this timer ON program is implemented and unit will be turned off automatically when the time of timer OFF has come.

If the unit is manually turned off by keyboard before the automatic turning off by the timer, this timer OFF program is implemented .

If everyday timezone setting is same, do not need to set day by day, just go to

Timezone on/off	
Monday:	
Copy from Monday	
Confirm:	NO

Change Monday to Tuesday, and change “No” to “Yes” ,then Tuesday’s timezone setting will be same as Monday.

With the same method to change Wednesday....etc.

# User Guide

## Compressor Operating hours

Display compressor operating hours.

Compressor Operating hours 000000hour
---

## Night mode

Outdoor fan could be set to run in lower speed at night to reduce noise level

Outdoor fan Night mode: Enable On: 22:00 Off: 06:00
--

Default setting of night mode is activated from 22:00 to 6:00.

The night mode time could be adjusted by the user.

## Insert User default

This function is to store user setting to factory default setting . Change “NO” to “YES”, press <Enter> , it will display “Operation succeed” .

## Important safety information for end users

Installation and service works of the heat pump should only be done by authorized installer and after sales people.

Do not let children to play the heat pump .

Under some conditions, the heat pump will need defrosting. Ice on the evaporator will be melt and a short cloud of condensation from the heat pump will come out. The surface below the heat pump will be wet due to the drained water from evaporator.

Do not attempt to modify, repair or service the appliance yourself.

Do not insert body parts or any other items into the air inlet or air outlet.

Do not start or stop the unit by removing the power cable; always use the controls and switches provided.

Do not operate the unit or controller with wet fingers.

Upon replacement of the fuse, ensure an adequate replacement is used (e.g. not fuse wire).

The electrical supply must be isolated during a heightened risk of lightning strikes.

Do not attempt to move the appliance once installed; this must be carried out by a qualified engineer.

Isolate the electrical supply to the appliance if an odour presents, or scorching is detected.

Only use this appliance for the purpose intended.

Ensure the area around the appliance is clean, well-ventilated and kept free of all obstructions.

Do not keep items on top of the appliance or use it to support other appliances.

Do not under any circumstances stand on the appliance.

Drain the water from the water circuit if power to the unit is to be switched off during very cold weather.

Periodically check the condition of any supports for deterioration.

Do not wash the unit with water, alcohol, benzene, thinners, glass cleaner, polish or powders.

During cleaning, isolate the electrical supply to the appliance.

# Service Guide

## Access Service Level Parameter data

<i>Display</i>	<i>Procedures</i>
<div style="border: 1px solid black; padding: 5px;"> <p>■ Enter password <span style="float: right;">0000</span></p> </div>	<p>press &lt;Prg&gt; to main menu, press Down button to Parameter, Press Enter button, Press Enter and 0 will flash, press Down button to the correct figure, press Enter to confirm. Likewise, change the other 3 figure .After 4 correct figure are inputted, It will enter Service level parameter.</p>
<div style="border: 1px solid black; padding: 5px;"> <p><b>Information</b> <span style="float: right;"><b>E01</b></span> CNHISmVAIE Ver. : <span style="float: right;">1.0.7</span> <span style="float: right;">2015/03/10</span></p> </div>	<p>Press Enter button, It display controller version information.</p>
<div style="border: 1px solid black; padding: 5px;"> <p><b>E02</b> SF01:Unit type <span style="float: right;">Cooling+Heating</span></p> </div>	<p>Press Down button, it goes to Unit type setting. Press Enter to confirm, when Cooling+heating is flashing, press Up or Down button to change the value. Press Enter to confirm. Cursor will move to E02 When E02 is flashing, press Down button to next parameters.</p>
<p>Or, continuously press &lt;Esc&gt; to exit out of the current level and back to the desired menu level.</p>	

# Service Parameters

Service Parameters:

Parameter	Descriptions	De-fault	Min.	Max.	Unit	Res
EV01	Water pump control mode	Continuous work	Continuous work or work by regulation			
EV03	Water pump set temp. difference on cooling	5	1	10	°C	0.1
EV04	Water pump set temp. difference on heating	5	1	10	°C	0.1
SF01	Unit type		Only heating or Cooling + Heating			
SF05	Enable domestic hot water function	YES	YES or NO			
SF13	HW On/Off way	Keyboard	Keyboard or remote			
SF14	AC On/Off way	Keyboard	Keyboard or remote			
DF03	Defrost start outdoor temperature	12	3.0	20.0	°C	0.1
DF04	Defrost temperature differential (OT-LPS))	13	5	20	°C	0.1
DF05	Defrost start delay after OT-LPS ≤DF04	15	1	60	Sec	1
DF06	Minimum defrost interval	30	15	60	Min	1
DF09	Defrost end HPS temperature	35	1	40	°C	0.1
DF10	Max. defrost time	360	1	1000	Sec	1
DF12	Defrost start evaporation temp.	-2	-5	5	°C	0.1
DF13	Fan start coil temp.	25	5	60	°C	0.1
DF15	De icing heater start ambient temperature	2	-10	10	°C	0.1
UI01	Service password		0000	9999	-	1

Service parameter is code protected and only could be adjusted when unit is OFF.



# Service Guide

## Cooling demand

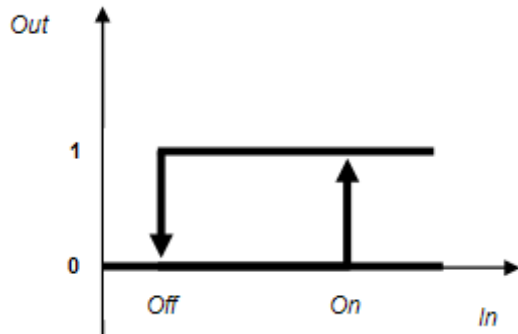

In: B1, B2

On:  $B1 > B1a + ST03$  (B1a is the measured sensor B1 temperature when the unit off condition is met. The first time unit on condition  $B1a = ST01 + 5$ )

Off:  $B2 < ST01$

## Heating demand

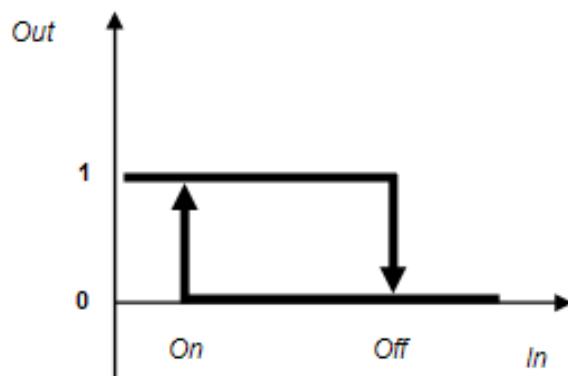

In: B1, B2

On:  $B1 < B1c - ST04$  (B1c is the measured sensor B1 temperature when the unit off condition is met. The first time unit on condition  $B1c = ST02 - 5$ )

Off:  $B2 > ST02$

## Domestic hot water demand

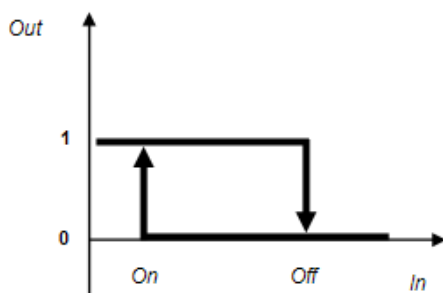

In: B4 (HT)

On:  $B4 < ST09 - ST10$

Off:  $B4 > ST09$

# Service Guide

## Control process

### Turn on process at heating mode

- 1.) Start water pump , check water flow switch
- 2.) 5 seconds after water flow switch closes, if there is heating demand, start fan and compressor

### Turn off process at heating mode

- 1.) Switch off compressor
- 2.) After 5 second's delay, switch off fan motor
- 3.) After 30 seconds' delay, switch off water pump .

### Turn on process at cooling mode

- 1.) Start water pump and 4 way valve, check water flow switch
- 2.) 5 seconds after water flow switch closes, if there is cooling demand, start fan and compressor

### Turn off process at cooling mode

- 1.) Switch off compressor
- 2.) After 5 second's delay, switch off fan motor
- 3.) After 30 seconds' delay, switch off water pump .
- 4.) After 60 seconds' delay, switch off 4 way valve.

### Turn on process at hot water mode

- 1.) start 3 way valve and water pump, check water flow switch.
- 2.) 5 seconds after water flow switch closes, start fan and compressor

### Turn off process at hot water mode

- 4.) Switch off compressor
- 5.) After 5 second's delay, switch off fan motor
- 6.) After 30 seconds' delay, switch off water pump and 3 way valve.

## Hot water priority:

- When unit is heating, if there is a call for hot water , it start 3 way valve at once and turn to hot water mode directly. It will revert back to heating mode after hot water reach set temperature.
- When unit is cooling, if there is a call for hot water , it stops compressor first and then start at hot water mode , it stops compressor again when hot water reach set temperature before it revert back to cooling mode.

## Water pump control (NO2)

water pump runs as below from stop to running mode:

EV01=Continuous work, water pump will continue to run until unit stops.

EV01=work by regulation, water pump will be ON when compressor is ON, will be OFF when compressor is OFF.

## 4 way valve control (NO3)

4 way valve is OFF on below conditions. It is ON at other conditions.

- 1.) Heating mode, hot water mode, or heating + hot water mode
- 2.) Producing hot water on cooling + hot water mode.

# Service Guide

## Auxiliary Electric heater or boiler control (NO4)

Auxiliary heater or boiler only could be switched on when all of conditions below are met.

- 1.) Heating mode running;
- 2.) Compressor has run over 300s
- 3.)  $OT \leq ST07$ ;
- 4.)  $ST \leq ST02-ST04-1$ ;

Auxiliary heater or boiler only could be switched off when any of conditions below is met.

- 1.) A/C flow switch cut off over 2s;
- 2.)  $ST \geq ST02-ST04$ ;
- 3.) unit is switched off
- 4.) ST sensor probe trouble

Auxiliary heater or boiler is switched on during defrosting period.

## Crankcase heater running control (N05)

When all of conditions below are met, compressor crankcase heater is switched on

- 1.) Compressor is OFF;
- 2.)  $OT \leq SF26$

When any of conditions below is met, compressor crankcase heater is switched off

- 1.) Compressor is ON;
- 2.)  $OT \geq SF26+1$

## 3 way valve control (NO7)

- 1.) 3 way valve is OFF when unit is cooling or heating .3 way valve is ON when unit is producing domestic hot water.
- 2.) If unit is defrosting on heating mode, 3 way valve is off at first, if  $ST \leq AR01$  and last 2 seconds, 3 way valve is switched ON. If  $ST \leq AR01$  and last 2 seconds again, it will report AL03 , exit defrosting and return to heating.
- 3.) If unit is defrosting on hot water mode, 3 way valve is on at first, if  $ST \leq AR01$  and last 2 seconds, 3 way valve is switched OFF. If  $ST \leq AR01$  and last 2 seconds again, it will report AL03 , exit defrosting and return to product hot water.

## Hot water heater control (NO8)

Hot water electric heater in the water tank could be switched on in periodic time (ST26) to a pre-set hot water temperature (ST27) to prevent legionella .Factory default setting of  $ST26=0$ ,  $ST27= 65^{\circ}\text{C}$ .

## De-icing heater running control (NO9)

When all of conditions below are met, de-icing heater is switched on

- Compressor is ON;
- Heating or DHW mode running
- Ambient temperature  $\leq DF15$

When any of conditions below is met, de-icing heater is switched off

- Compressor is OFF;
- Ambient temperature  $> DF15+2$ ;

# Service Guide

## The EC fan running control (Y1)

On cooling mode, ambient temperature  $\geq$  CN05, fan runs as CN01, ambient temperature  $\leq$  CN06, fan runs as CN03, CN06  $<$  ambient temperature  $<$  CN05, fan runs on the speed proportionally between CN03 and CN01.

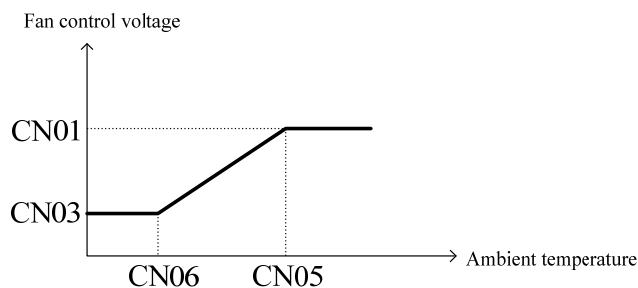

Heating and DHW mode, ambient temperature  $\leq$  CN07, fan runs as CN02, ambient temperature  $\geq$  CN08, fan runs as CN03, CN07  $<$  ambient temperature  $<$  CN08, fan runs on the speed proportionally between CN03 and CN02.

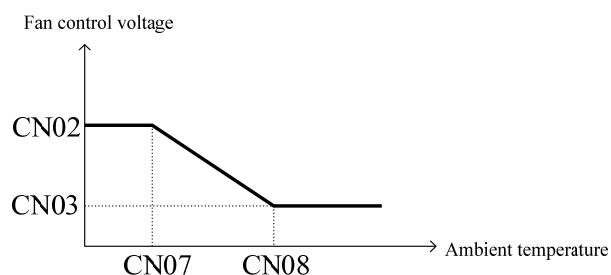

## The EC fan input control voltage and speed table

Series No.	Input control Voltage	Speed (rpm)
1	2.8V	451
2	2.9V	490
3	3.0V	520
4	3.1V	551
5	3.2V	605
6	3.3V	654
7	3.4V	684
8	3.5V	706
9	3.6V	754
10	3.7V	780
11	3.8V	817
12	3.9V	838
13	4.0V	870
14	4.1V	892
15	4.2V	921
16	4.3V	938
17	4.4V	963
18	4.5V	985
19	4.6V	1017

# Service Guide

On cooling mode, when compressor is on, pump PWM runs as EV05 for 3 minutes, then runs with  $(\text{Inlet temperature} - \text{Outlet temperature}) = \text{EV03}$  as target via PID control. When compressor is off, pump PWM runs as EV06.

On heating mode, when compressor is on, pump PWM runs as EV05 for 3 minutes, then runs with  $(\text{outlet temperature} - \text{Inlet temperature}) = \text{EV04}$  as target via PID control; when compressor is off, pump PWM runs as EV06.

On DHW mode, pump PWM runs as EV05. After DHW temperature reaches preset temperature, if the unit does not need to do cooling or heating, pump PWM is off.

pump PWM runs as EV05 on defrosting.

As other situation, when pump is on, PWM is EV06, PWM is off when pump is off.

Pump PWM will start running for 3 minutes when pump is off for 24 hours to avoid seizure

## Defrosting control

The unit is equipped with hot gas defrosting. When the conditions of defrosting starting are met, the fan stops, the 4 way valve changes direction and the hot gas flows out to the finned coil heat exchanger instead. After the condition of defrosting exit is met, the fan starts, the hot gas flows into brazed plate heat exchanger and the unit returns to normal operation.

### Defrosting starting conditions (all must be met)

Ambient temperature  $B3 < DF03$

The unit running time after previous defrosting  $> DF06$

Ambient temp.  $B3$  minus LPS  $B11 > DF04$ , last  $DF05$  time

$LPS B11 \leq DF12$ ;

### Defrosting exit condition (any of the following condition is met)

$HPS B12 \geq DF09$ , last 10 seconds.

Defrost time  $\geq DF10$

Temperature sensor  $B1, B2, B6, B11$  or  $B12$  trouble.

# Manufacturer parameters

## Access Manufacturer Level Parameter data

<i>Display</i>	<i>Procedures</i>
<div style="border: 1px solid black; padding: 5px; display: flex; justify-content: space-between;"> <span>Enter password</span> <span>0000</span> </div>	<p>press &lt;Prg&gt; to main menu, press Down button to Parameter, Press Enter button, Press Enter and 0 will flash, press Down button to the correct figure, press Enter to confirm.</p> <p>Likewise, change the other 3 figure .After 4 correct figure are inputted, It will enter Service level parameter.</p>
Service	<p>If the inputted password is service, it will just enter Service level parameters.</p> <p>If the inputted password is manufacturer, it will access both service and manufacturer level parameter.</p>
Manufacturer	<p>press Down button to Manufacturer Parameter</p>
<div style="border: 1px solid black; padding: 5px;"> <p><b>Comp. management</b> <span style="float: right;"><b>P02</b></span></p> <p>CM01:Min on <span style="float: right;">180s</span></p> <p>CM02:Min off <span style="float: right;">300s</span></p> </div>	<p>Press Down button, it display parameter and data.</p> <p>Press Enter to confirm, when data is flashing, press Up or Down button to change the value.</p> <p>Press Enter to confirm.</p> <p>Cursor will move to P02</p> <p>When P02 is flashing, press Down button to next parameters.</p>
<p>Or, continuously press &lt;Esc&gt; to exit out of the current level and back to the desired menu level.</p>	

Warning : Manufacturer parameter is related to the unit safe running and reliability. It is not supposed to be changed without manufacturer's permission. Any wrong change could possibly cause the unit broken.

# Manufacturer parameters

Para meter	Descriptions	Default	Min.	Max.	Unit	Res
CM01	Compressor minimum ON time	180	90	900	Sec.	1
CM02	Compressor minimum OFF time	300	90	1000	Sec.	1
CN01	EC fan Max. speed (cooling)	4	1	10	V	0.1
CN02	EC fan Max. speed (heating)	4	1	10	V	0.1
CN03	EC fan Min.. speed	3	1	10	V	0.1
CN04	EC fan Max speed (night mode)	4	1	10	V	0.1
CN05	EC fan PWM start ambient temp. (cooling)	35	0	50	°C	0.1
CN06	EC fan PWM end ambient temp. (cooling)	0	0	50	°C	0.1
CN07	EC fan PWM start ambient temp. (heating and DHW)	7	0	50	°C	0.1
CN08	EC fan PWM end ambient temp. (heating and DHW)	35	0	50	°C	0.1
EV05	PWM pump Max. speed	100	10	100	-	1
EV06	PWM pump Min. speed	30	10	100	-	1
EV07	Pump integral time	300	0	900	Sec.	1
EV08	Pump derivative time	1	0	90	Sec.	1
EV13	Pump control band on cooling	4	0.5	20	°C	0.1
EV14	Pump control band on heating	4	0.5	20	°C	0.1
SF06	Antifreeze start external temp.	2	0	10	°C	0.1
SF07	Antifreeze end external temp. difference	1	1	10	°C	0.1
SF08	Antifreeze start outlet water temp.	10	1	20	°C	0.1
SF09	Antifreeze end outlet water temp. difference.	5	1	10	°C	0.1
SF11	Discharge super heat setup	25	20	50	°C	0.1
SF12	Regulation circle	12	1	90	S	0.1
SF20	Super heat setup	5	-72	99.9	°C	0.1
SF25	Refrigerant type	R410A				
AR01	Low outlet water temperature protection	5	1	10	°C	0.1
AR03	High outlet water temperature protection	58	1	100	°C	0.1
AR04	Water flow switch start-up delay time	30	1	300	Sec.	1
AR06	Low pressure alarm times within 24 hours	4	1	10	-	1
AR07	High pressure alarm times within 24 hours	6	1	10	-	1
AR08	low suction temperature protection	-2	-10	10	°C	0.1
AR09	Low pressure switch start-up delay time	300	10	1000	Sec.	1
AR10	High discharge gas temperature protection	115	100	130	°C	0.1
AR11	Antifreeze detect interval	30	1	1000	Min.	1
AR13	Low suction pressure alarm	1	0	25	bar	0.1
AR14	Low suction pressure alarm differential	1.5	0	15	bar	0.1
AR15	High discharge pressure alarm	42	0	50	bar	0.1
AR16	High discharge pressure alarm differential	6	0	15	bar	0.1
SF26	Crankcase heater start external temperature	10	0	30	°C	0.1
SF32	High pressure transmitter max. range	45	0	99	bar	0.1
SF34	EEV steps in defrost	250	0	470	stp	1
SF35	Compressor switch on delay on defrost	30	0	600	s	0.1
SF36	EEV steps limit	30	30	480	stp	1
SF37	EEV delay	60	0	900	s	1
ST11	Minimum user setup cooling temperature	6	0	ST12	°C	0.1
ST12	Maximum user setup cooling temperature	40	ST11	60	°C	0.1
ST13	Minimum user setup heating temperature	20	0	ST24	°C	0.1
ST14	Maximum user setup heating temperature	55	ST13	80	°C	0.1
ST15	Minimum user setup hot water temperature	20	0	ST16	°C	0.1
ST16	Maximum user setup hot water temperature	55	ST15	80	°C	0.1
UI02	Manufacturer password		0000	9999	-	1

Manufacturer parameter is code protected and only could be adjusted when unit is OFF.

CN02 Max. EC motor speed should not be over 4.6V in case of overheating.

# Commissioning and Adjusting

## Preparations- Filling and Flushing

1. Before commissioning, ensure the whole system has been properly flushed and filled with water.
2. Check the pipe work system for leaks.
3. The heating system is filled with water and inhibitor to the required pressure between 100-200 kPa or 15-30PSI.
4. Vent air out the system using the air venting valves.

## Compressor oil heater

- The unit is equipped with a compressor oil heater which heats the compressor oil before start-up when outdoor temperature is low.
- The unit must be in the standby state for 6-8 hours before the unit is switched on for the first time. This is so the compressor oil heater has the compressor oil at the correct temp before the FIRST start, this will ensure no damage is done to the compressor on start up.

## Startup and Inspection

1. Turn the isolator switch on.

**Note:**

***Ensure that the heating control system is in the off position first.***

2. The compressor oil heater must have been operational for at least 6–8 hours before a compressor start can be initiated.
3. Start the unit by turning on the heating control system and therefore switching on the unit.
4. The water pump will start (the flow switch should operate), then fan motor, and finally the compressor.
5. Adjust the flow rate to make water inlet/outlet temperature difference around 5°C.

The temperature difference between ST/RT can be adjusted by increasing the flow rate by either using circulation pumps or control valve.



# Commissioning and Adjusting

## Air in the System after Startup

- Air will initially be released from the water as its heated and further venting may be required.
- If a bubbling sound can be heard from the heat pump, the circulation pump, underfloor and or radiators then the entire system will require further venting.
- When the system is stable (correct pressure and all air eliminated) the automatic heating control system can be set as required.

## Temperature sensor calibration.

If the temperature sensor readings is with some error. Service parameter come with calibration function.

## Insert default setting

Among User, service and manufacturer parameters, there is a function to insert each privilege level factory default setting . Change “NO” to “YES”, press <Enter> , it will display “Operation succeed” .

## Initialization

On manufacturer parameter, initialization function could restore all user, service and manufacturer parameters to factory default settings. Change “NO” to “YES”, press <Enter> , it will display “Are you sure?” ,press <Enter> to confirm. It display “Loading... ”. then “Warning Initialization done, please switch-off !. The controller needs to be power off and then power on again.

## Reset comp operating hours

Change “No” to “Yes” could reset compressor operating hours to 0.

# Commissioning Form



<b>Commissioning Form</b>			
Client / Installation address:		Telephone Number	
Installer:		Commissioned by	
Heat pump Model:		Heat pump serial number:	
Commissioning date:			
The heating system has been filled and pressure tested			YES ( )
Expansion vessel for heating is sized, fitted & charged in accordance with manufacturer's instructions			YES ( )
The heat pump is fitted on a solid/stable surface capable of taking its weight			YES ( )
The system has been flushed and cleaned in accordance with heat pump manufacturer's instructions			YES ( )
What system cleaner was used?			
What inhibitor was used?			Qty:( ) litres
Are all exposed external pipeworks insulated?			YES ( )
<b>Central heating mode ( 10 minutes after compressor start to run)</b>			
Is buffer tank installed			Capacity:( ) litres
Inlet	( )°C	discharge	( )°C
outlet	( )°C	suction	( )°C
ambient	( )°C	HPS	( )°C
Hot water	( )°C	LPS	( )°C
Power voltage	( )V	Current	( )A
<b>Domestic hot water mode ( 10 minutes after compressor start to run)</b>			
Is a hot water cylinder installed	Capacity:( ) litres	Heating coil diameter ( )mm,	length ( )m
Inlet	( )°C	discharge	( )°C
outlet	( )°C	suction	( )°C
ambient	( )°C	HPS	( )°C
hot water	( )°C	LPS	( )°C
Power voltage	( )V	Current	( )A
Additional heat sources connected: Gas Boiler ( ) Oil Boiler ( ) Electric Heater ( ) Solar Thermal ( )			YES ( )
The heating, hot water and ventilation systems complies with the appropriate Building Regulations			YES ( )
All electrical work complies with the appropriate Regulations			YES ( )
The heat pump and associated products have been installed and commissioned as the manufacturer's instructions			YES ( )
The operation of the heat pump and system controls have been demonstrated to the customer			YES ( )
The operation, installation and maintenance manual has been explained and left with the customer			YES ( )
Commissioning Engineer's Signature			
Customer's Signature (To confirm demonstration of equipment and receipt of appliance instructions)			

# Alarms

The alarms are divided into two groups: auto reset alarms and manual reset alarms.

1. Auto reset alarm, the user is not required to acknowledge and reset it.
2. The corresponding device will be automatically restarted once the alarm status disappears.
3. Once a manual reset alarm is detected, the system will be stopped automatically. The user needs to record and contact the supplier on actions what to do.
4. To acknowledge and reset the alarm press the  button.
5. Ensure that the fault has been fixed before the alarm has been reset.

When an alarm is detected:

- The  icon will continuously flash. An alarm code will be displayed on the screen.
- If more than one alarm is detected, the alarm codes will be displayed successively on the LCD screen. These will be seen by using the  or  buttons, or they are manually acknowledged or reset (only for manual reset alarms).

# Alarms

## Auto Reset Alarms

The following are codes for auto reset alarms with their meanings.

Codes	Meaning
AL03	Low outlet water temperature (ST<AR01)
AL05	High outlet water temperature (ST>AR03)
AL17	Water flow switch
AL26	Antifreeze
AL35	Low suction pressure ,lower than 1.5bar
AL36	High discharge pressure ,higher than 42bar
AL37	Suction pressure transmitter alarm (B11)
AL38	Discharge pressure transmitter alarm(B12)
Display offline	Wired remote control and main board communication trouble.
AL71	RT sensor trouble (over 150 °C or lower than -35 °C) (B1)
AL72	ST sensor trouble (over 150 °C or lower than -35 °C) (B2)
AL73	OT sensor trouble (over 150 °C or lower than -35 °C) (B3)
AL74	HT sensor trouble (over 150 °C or lower than -35 °C) (B4)
AL75	PT sensor trouble (over 150 °C or lower than -35 °C) (B5)
AL76	ET sensor trouble (over 150 °C or lower than -35 °C) (B6)

## Manual Reset Alarms

The following are codes for manual reset alarms with their meanings.

Codes	Meaning
AL20	Low suction temperature (AR08)
AL21	High exhaust gas temperature (over AR10 )
AL23	Phase relay
AL24	Compressor overload
AL32	Low pressure alarms from transmitter times is over the limit(AR06)
AL33	High pressure alarms from transmitter times is over the limit(AR07)

# Alarms

## Viewing Alarm history

<i>Display</i>	<i>Procedures</i>
Press <Prg> button , then then press down button to Alarm History, press <Enter> to confirm.	
<div data-bbox="260 629 625 759" style="border: 1px solid black; padding: 5px;"> <p>Alarm history</p> <p>No 014 16:58 18/12/13</p> <p>AL02</p> <p>High pressure</p> </div>	Press <up> or <down> to view other alarms
<div data-bbox="260 866 625 994" style="border: 1px solid black; padding: 5px; text-align: center;"> <p>No alarm!</p> </div>	If no alarm is generated, the word “No alarm!” will be displayed.

## Acknowledging and Resetting Manual Reset Alarms

Any alarm detected by the system, either an auto reset alarm or a manual reset alarm will be displayed on the LCD. However, only manual reset alarms require user’s acknowledgement and reset.

- To clear the alarm press < > to acknowledge the alarm.

If the alarm status is cleared, the corresponding device icon and alarm icon  that are flashing will accordingly disappear.

# Alarms

## **Low outlet water temperature protection (Code: AL03)**

At any mode, if  $ST \leq AR01$ , the compressor is off, after 5 seconds delay, the fan motor will be stopped, PWM water pump will run as EV05, other parts will keep its original state. A continuous blink warning code AL03 will appear on the LCD, it will record the instant inlet water temperature RT1 and will return to normal working after inlet water temperature  $RT \geq RT1 + ST03$ .

## **High outlet water temperature protection (Code: AL05)**

If  $ST \geq AR03$ , the compressor is off, after 5 seconds delay, the fan motor will be stopped, PWM water pump will run as EV05, other parts will keep its original state. A continuous blink code AL05 will appear on the LCD, it records instant inlet water temperature RT2 and will return to normal working after inlet water temperature  $RT \leq RT2 - ST04$ .

## **Water flow switch protection (Code: AL17)**

At starting process, if water flow switch does not close after AR04 time (DI1=OFF) after starting the water pump, a continuous blink warning code AL17 will appear on the LCD. If DI1=ON and last 5 seconds, it will return back to work.

During unit working, if DI1=OFF and lasts 5s, the compressor is off, after 5 seconds delay, the fan motor will be stopped, PWM water pump will run as EV06, other parts will keep its original state, a continuous blink warning code AL17 will appear on the LCD.

After AL17 alarm happen, if DI1=ON and lasts 5s, unit will return to normal working.

## **Low evaporate temperature protection (Code: AL20)**

The protection function will be valid at COOLING mode.

20 seconds after compressor working, if suction temperature  $\leq AR08$ , the compressors is off, 5 seconds later, fan motor will be stopped, PWM pump runs as EV06, other parts will keep its original state, a continuous blink warning code AL20 will appear on the LCD.

## **High exhausted gas temperature protection (code: AL21)**

Discharge gas temperature  $> AR10$  and lasts 5 seconds, the compressors is off, 5 seconds later, fan motor will be stopped, PWM pump runs as EV06, other parts keep original state. LCD display AL21 and flash.

## **Low pressure protection (Code: AL35)**

After starting the compressor, it will check the low pressure after AR09 delay. If  $LPS \leq AR13$ , the compressor is off, 5 seconds later, fan motor will be stopped, PWM water pump will run as EV06, other parts will keep its original state. A continuous blink code AL35 will appear on the LCD, until  $B11 (LPS) \geq AR13 + AR14$ , the unit will turn to its normal work.

## **Low pressure protection (serious) (Code: AL32)**

If in 24 hours time, AL35 happening times is over AR06, manual reset alarm AL32 will happen, the compressor is off, 5 seconds later, fan motor will be stopped, PWM water pump will run as EV06, other parts will keep its original state. A continuous blink code AL32 will appear on the LCD.

# Alarms

## **High pressure protection (Code: AL36)**

It does not scan high pressure on defrosting period and within 10 seconds after defrosting stop. At other time if  $B12(HPS) \geq AR15$ , the compressor is off, after 5 seconds delay, the fan motor will be stopped, PWM water pump will run as EV06, other parts will keep its original state. A continuous blink code AL36 will appear on the LCD, until  $B12(HPS) \leq AR15-AR16$ , the unit will turn to its normal work.

## **High pressure protection (serious) (Code: AL33)**

If in 24 hours time, AL36 happening times is over AR07, manual reset alarm AL33 will happen, the compressor is off, 5 seconds later, fan motor will be stopped, PWM water pump will run as EV06, other parts will keep its original state. A continuous blink code AL33 will appear on the LCD.

## **Anti-freeze protection (Code : AL26)**

When water pump is off and ambient temperature  $\leq SF06$ , water pump will be switched on in every AR11 interval, PWM is EV05. 180 seconds later,

If outlet water temperature  $> SF08$ , switch off water pump.

If outlet water temperature  $\leq SF08$  and unit is off state, if water flow switch is closing, A/C auxiliary heater is switched on. If water flow switch is opening, it does not switch on A/C auxiliary heater and displays AL26. Until outlet water temperature  $\geq SF08+SF09$ , it switches off A/C auxiliary heater, 10 seconds later, switches off water pump. If the units is switched on, it will be on.

When the unit is on standby state at hot water mode, if ambient temperature  $\leq SF06$ , water pump and 3 way valve will be switched on in every AR11 interval, PWM is EV05. It will switch water pump when outlet water temperature  $> SF08$ .

If outlet water temperature sensor is out of order, inlet water temperature sensor will be replaced as antifreeze water temperature reference. If inlet water temperature sensor is out of order too, water pump will continue to run until  $OT > SF06+SF07$

## **Display offline - Wired remote control and main board communication trouble.**

After this trouble happen, unit still can work normally but the wired remote control can not be used to operate the unit.

# Alarms

## Temperature Sensor trouble (auto reset)

If the temperature sensor is below -35C or higher 150C in 4.5 seconds, it will display sensor trouble.

sensor	code	Program trouble dealing action
B1	AL71	Unit will continue to run until it reaches preset temperature. CM02 later, it will start again.
B2	AL72	Switch off the unit
B3	AL73	Unit will continue to run according to SF04=0 on heating mode.
B4	AL74	Hot water mode is invalid. Alarm code displays if SF05=1. Alarm code does not display if SF05=0.
B5	AL75	Switch off the unit
B6	AL76	Cancel AL20 protection, increase ST01 2 degree Celsius more.
B7	AL77	Switch off the unit
B11	AL37	Switch off the unit
B12	AL38	Switch off the unit



# Maintenance

To ensure the optimal performance of the unit regular maintenance is essential. Failure to undertake regular maintenance can reduce the unit performance and of the system shorten the life of the unit .

## Exterior Maintenance

1. Make regular checks throughout the year that the inlet grill is not blocked or clogged by leaves, snow or anything else.
2. Ensure during the colder times of the year that there isn't too much frost or ice building up on or around the unit.
3. Periodically inspected for loose, damaged or broken parts. If these faults are found and not eliminated, the unit could cause physical injury and damage to people, goods and property.
4. Regularly carry out leak checks and immediately repair any leak found. If there is a leak in the plate heat exchanger, this part must be replaced.

## Unit Refrigerant Checks

1. Verify the air grills are clear and clean it at least once a year, or more often if the equipment environment is especially demanding, this ensures that the unit's performance can be maintained.
2. Check the operation of the high-pressure and low pressure switches. Replace them if there is a fault.
3. Check the fouling of the filter dryer (by checking the temperature difference in the copper piping). Replace it if necessary.

Full-load operating test verify the following values:

- A. Compressor high-pressure side discharge pressure
- B. Compressor low-pressure side suction pressure
- C. Charge visible in the sight glass
- D. Verify the charge status by checking the colour indicator of the sight glass
- E. If the colour has turned to yellow, if so change the charge and replace the filter dryer after carrying out a leak test of the circuit
- F. Temperature difference between the heat exchanger water inlet and outlet temperature
- G. Actual liquid sub-cooling, overheating at the expansion device on heat pumps verify correct defrost of the air heat exchanger

# Maintenance

If there is not enough refrigerant in the system, this is indicated by gas bubbles in the moisture sight glass .the unit will have poor performance.

If the low refrigerant charge is significant, large bubbles appear in the moisture sight glass and the suction pressure drops, then the compressor suction superheat will also be high.

Find the leak and completely drain the system with a refrigerant recovery unit. Carry out the repair, leak test and then recharge the system.

**Note:**

*After the leak has been repaired, the circuit must be tested, without exceeding the maximum low-side operating pressure shown on the unit name plate.*

*The refrigerant must always be recharged in the liquid state into the liquid line.*

*The refrigerant cylinder must always contain at least 10% of its initial charge.*

*For the refrigerant quantity per unit, refer to the data on the unit name plate.*

## Verify the Alarm Status

1. Check the alarm menu when the unit is in the standby mode to see if any alarms or warning have occurred.

## Electrical Maintenance

1. Check for correct termination tension of the electrical connections, contactors, isolation switch and transformer.
2. Check the condition of the contactors, fuses and capacitors,
3. Check the condition of the electrical cables and their insulation.
4. Carry out an operating test of tray de-icing heater, compressor oil heater, refrigerant valve and expansion device.
5. Check the phase/earth insulation of the compressors, fans and pumps.
6. Check the compressor, fan and pump winding status.

# Maintenance

## **Mechanical Maintenance**

1. Check the tension of the fan motor, fan wheel, compressor and control box fixing bolts.
2. Check that no water has penetrated into the control box.

## **Evaporator Coil**

It is recommended that the finned coils are inspected regularly to check the degree of fouling. This depends on the environment where the unit is installed, areas by the sea can cause increase corrosion and an approved sprayed film coating is recommended.

For coil cleaning proceed as follows:

1. Remove fibers and dust collected on the evaporator face with a soft brush (or vacuum cleaner).
2. Clean the coil with the appropriate cleaning agents

## **Water Circuit Checks**

1. Clean the water filter if fitted.
2. Purge the system to remove any air.
3. Verify the correct operation of the water flow switch.
4. Check the status of the thermal piping insulation.
5. Check the water flow by checking the water inlet and outlet temperature difference.
6. Check the concentration of the anti-freeze protection solution (ethylene glycol or polyethylene glycol).
7. Check the status of the heat transfer fluid or the water quality.
8. Check the expansion tank for signs of excessive corrosion or gas pressure loss and replace it, if necessary.
9. Check that the water pressure safety valve is not leaking
10. Check that the air vent valves are not leaking system water

# Dimensions

AS10S/L AS13S/L

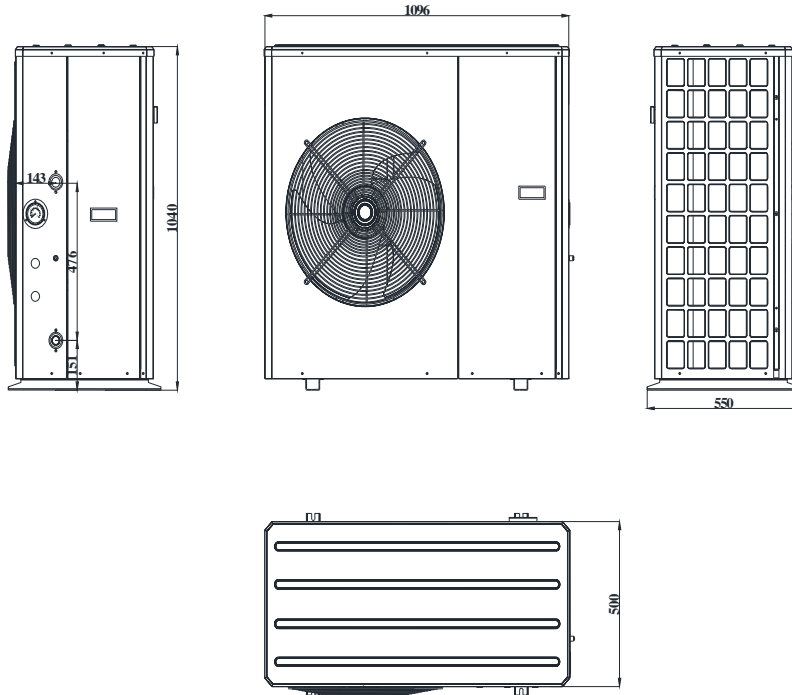

AS20S/L

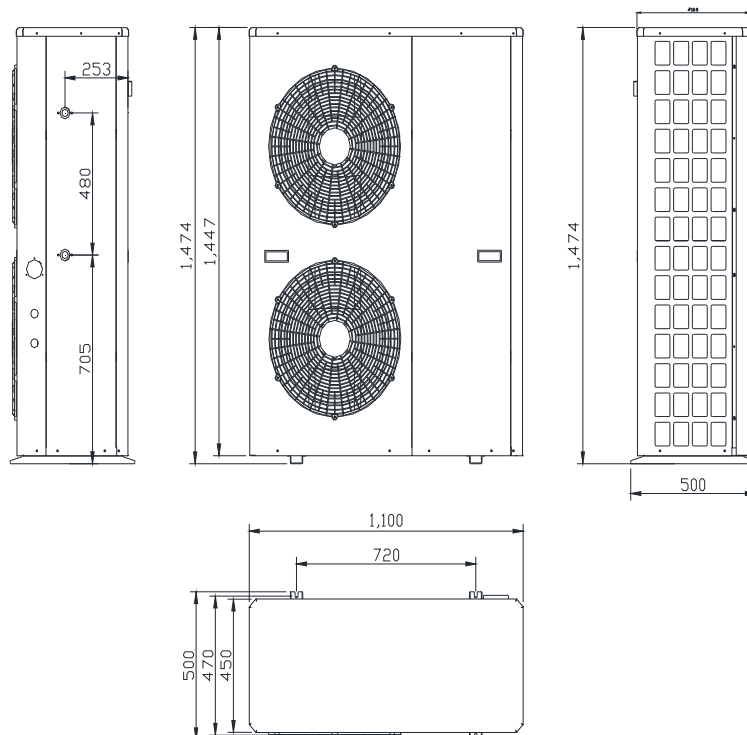

# Water Pressure Plots

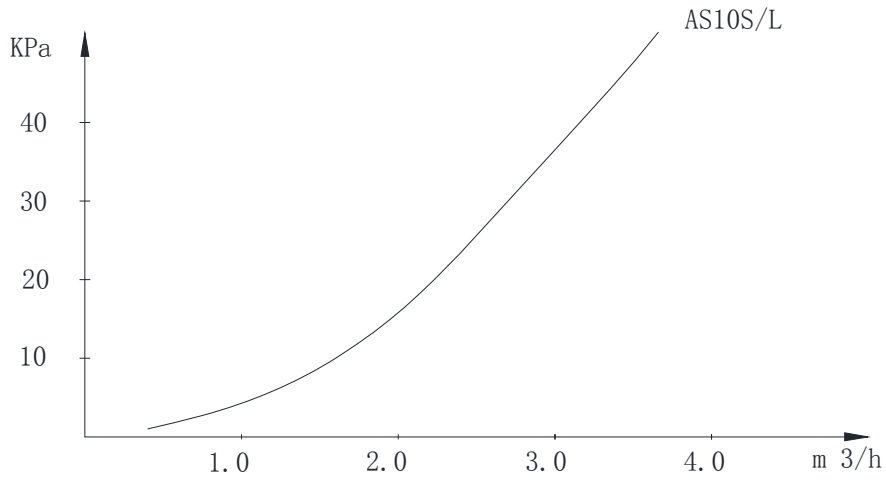

Optional high efficiency pump curve (AS10S/L )

## UPM3 FLEX AS 25-70 130

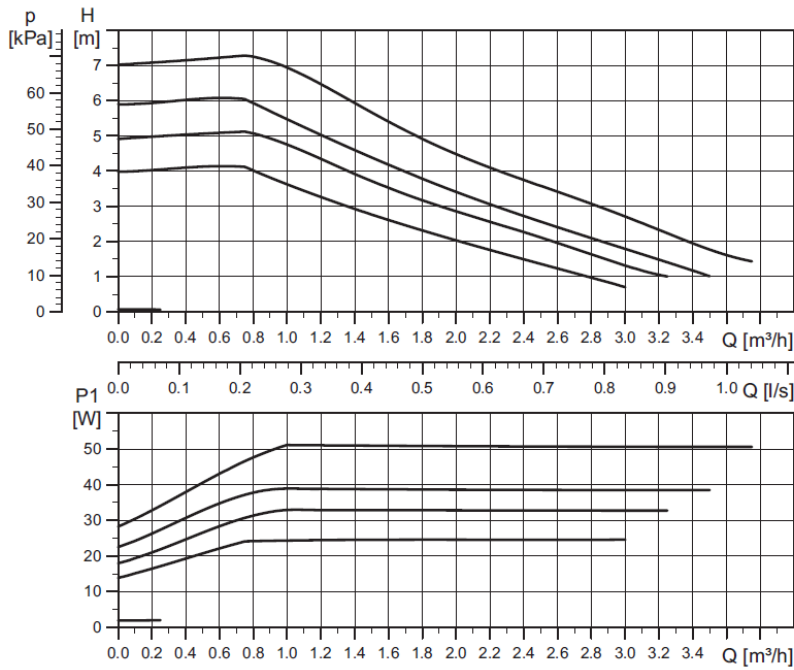

High efficiency

Ready for Ecodesign  
2015

$E_{EI} \leq 0.20$  Part 3

$P_{L,avg} \leq 23$  W

# Water Pressure Plots

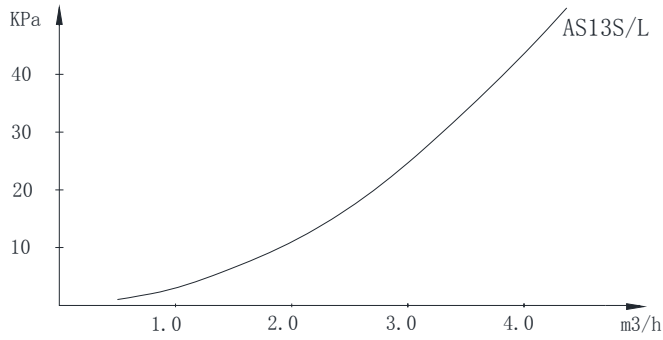

Optional high efficiency pump curve (AS13S/L)

**UPML 25-105 130 PWM, 1 x 230 V, 50/60 Hz**

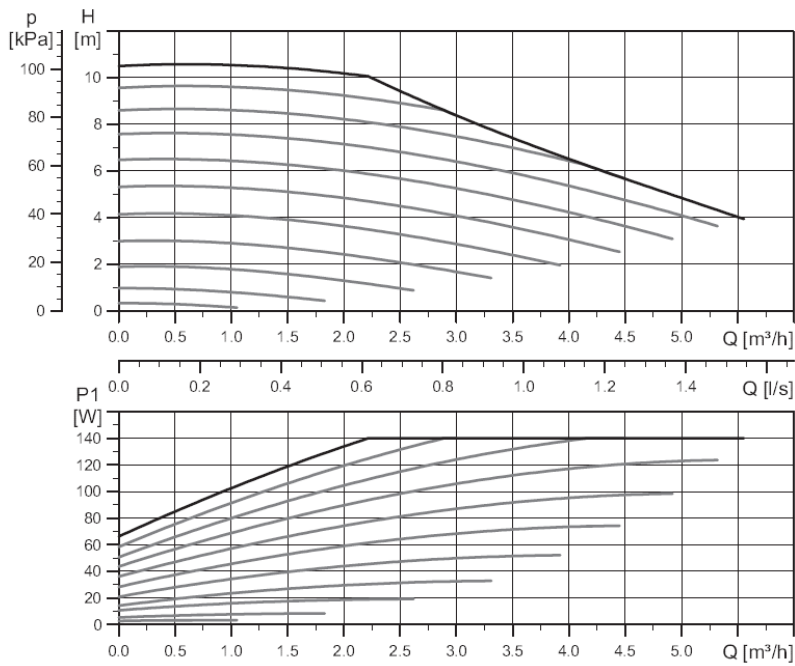

EEI ≤ 0.23

# Water Pressure Plots

AS20S/L

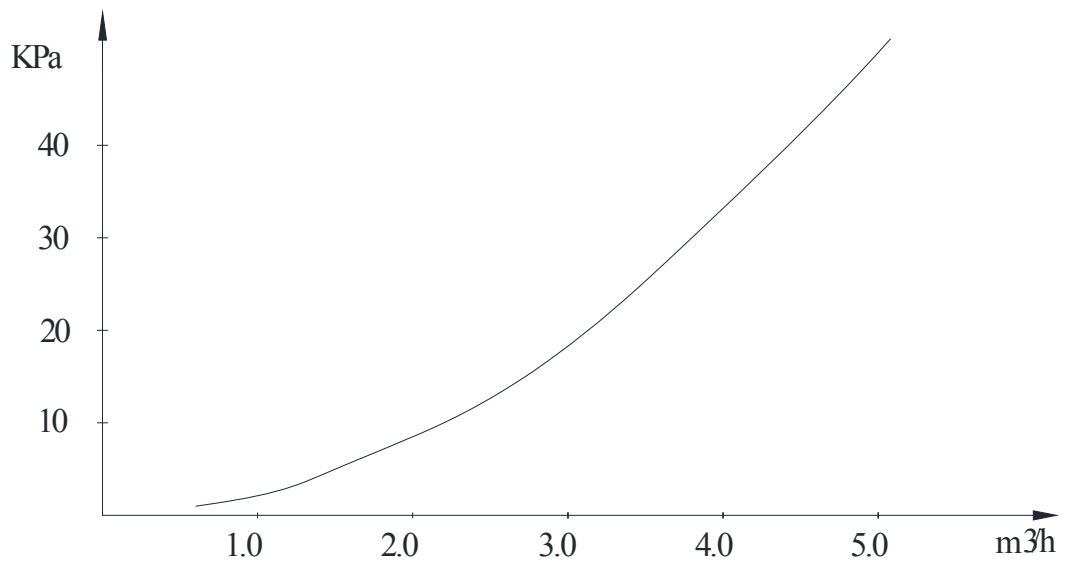

# Temperature and sensor resistance table

## Temperature and sensor resistance table

Except B5 PT sensor, other temperature sensors from B1 to B8 is NTC10K

### NTC10K@25°C β 3435

Temp. °C	resistant		
	Max KΩ	standard KΩ	Min. KΩ
-50	344.40	329.20	314.70
-49	324.70	310.70	297.20
-48	306.40	293.30	280.70
-47	289.20	277.00	265.30
-46	273.20	261.80	250.60
-45	258.10	247.50	237.20
-44	244.00	234.10	244.60
-43	230.80	221.60	212.70
-42	218.50	209.80	201.50
-41	206.80	198.70	191.00
-40	195.90	188.40	181.10
-39	185.40	178.30	171.59
-38	175.50	168.90	162.00
-37	166.20	160.10	154.10
-36	157.50	151.80	140.20
-35	149.30	144.00	138.80
-34	141.60	136.60	131.80
-33	134.40	129.70	125.20
-32	127.60	123.20	118.90
-31	121.20	117.10	113.10
-30	115.10	111.30	107.50
-29	109.30	105.70	102.20
-28	103.80	100.40	97.16
-27	98.63	95.47	92.41
-26	93.75	90.80	87.93
-25	89.15	86.39	83.70
-24	84.82	82.22	79.71
-23	80.72	78.29	75.93
-22	76.85	74.58	72.36
-21	73.20	71.07	68.99
-20	69.74	67.74	65.80
-19	66.42	64.54	62.72
-18	63.27	61.52	59.81
-17	60.30	58.66	57.05
-16	57.49	53.39	51.97
-15	54.83	53.39	51.97
-14	52.31	50.96	49.83
-13	49.93	48.65	47.12
-12	47.67	46.48	45.31
-11	45.53	44.41	43.32
-10	43.50	42.25	41.43
-9	41.54	40.56	39.59
-8	39.68	38.76	37.85
-7	37.91	37.05	36.20
-6	36.24	35.43	34.02
-5	34.65	33.89	33.14
-4	33.14	32.43	31.73
-3	31.71	31.04	30.39
-2	30.35	29.72	29.11
-1	30.00	28.47	27.89
0	27.83	27.28	26.74

Temp. °C	resistant		
	Max KΩ	Standard KΩ	Min. KΩ
1	26.64	26.13	25.52
2	25.51	25.03	24.55
3	24.24	23.99	23.54
4	23.42	22.99	22.57
5	22.45	22.05	21.66
6	21.52	21.15	20.78
7	20.64	20.29	19.95
8	19.80	19.40	19.15
9	19.00	18.70	18.40
10	18.24	17.96	17.67
11	17.51	17.24	16.97
12	16.80	16.55	16.31
13	16.13	15.90	15.87
14	15.50	15.28	15.06
15	14.89	14.68	14.48
16	14.31	14.12	13.93
17	13.75	13.57	13.40
18	13.22	13.06	12.89
19	12.72	12.56	12.41
20	12.23	12.09	11.95
21	11.77	11.63	11.57
22	11.32	11.20	11.07
23	10.90	10.78	10.60
24	10.49	10.38	10.27
25	10.10	10.00	9.90
26	9.73	9.63	9.52
27	9.38	9.28	9.18
28	9.04	8.94	8.84
29	8.72	8.62	8.52
30	8.41	8.31	8.21
31	8.11	8.01	7.91
32	7.82	7.72	7.62
33	7.55	7.45	7.35
34	7.28	7.19	7.09
35	7.03	6.94	6.84
36	6.79	6.69	6.60
37	6.56	6.46	6.37
38	6.33	6.24	6.15
39	6.12	6.03	5.94
40	5.92	5.82	5.73
41	5.72	5.63	5.54
42	5.53	5.43	5.35
43	5.34	5.25	5.17
44	5.16	5.08	4.99
45	4.99	4.91	4.82
46	4.83	4.74	4.66
47	4.67	4.59	4.51
48	4.52	4.44	4.36
49	4.38	4.30	4.22
50	4.24	4.16	4.08
51	4.10	4.02	3.95
52	3.97	3.90	3.82
53	3.84	3.77	3.69
54	3.72	3.65	3.57
55	3.61	3.53	3.46

Temp. °C	resistant		
	Max KΩ	Standard KΩ	Min. KΩ
56	3.49	3.42	3.35
57	3.39	3.31	3.24
58	3.28	3.21	3.14
59	3.18	3.11	3.04
60	3.09	3.02	2.95
61	2.99	2.92	2.86
62	2.90	2.83	2.77
63	2.81	2.75	2.69
64	2.73	2.66	2.60
65	2.65	2.58	2.52
66	2.57	2.51	2.45
67	2.49	2.43	2.37
68	2.42	2.36	2.30
69	2.35	2.29	2.24
70	2.28	2.22	2.17
71	2.21	2.16	2.10
72	2.15	2.10	2.04
73	2.09	2.04	1.98
74	2.03	1.98	1.93
75	1.97	1.92	1.87
76	1.92	1.87	1.82
77	1.86	1.81	1.78
78	1.81	1.76	1.71
79	1.76	1.71	1.68
80	1.71	1.66	1.62
81	1.66	1.62	1.57
82	1.62	1.57	1.53
83	1.57	1.53	1.49
84	1.53	1.49	1.44
85	1.49	1.45	1.40
86	1.45	1.41	1.37
87	1.41	1.37	1.33
88	1.37	1.33	1.29
89	1.34	1.30	1.26
90	1.30	1.26	1.22
91	1.27	1.23	1.19
92	1.23	1.20	1.16
93	1.20	1.16	1.13
94	1.17	1.13	1.10
95	1.14	1.10	1.07
96	1.11	1.08	1.04
97	1.08	1.05	1.01
98	1.05	1.02	0.99
99	1.03	0.99	0.96
100	1.00	0.97	0.94
101	0.98	0.94	0.91
102	0.95	0.92	0.89
103	0.93	0.90	0.87
104	0.91	0.87	0.84
105	0.88	0.85	0.82
106	0.86	0.83	0.80
107	0.84	0.81	0.78
108	0.82	0.79	0.76
109	0.80	0.77	0.74
110	0.78	0.75	0.73



# Temperature and sensor resistance table

B5 PT is NTC 50K sensor

## NTC 50K@25°C B 3977

### Temp. -resistant

Temp. °C	resistant KΩ	TCR %/°C	Min. KΩ	Max. KΩ	% tolerance		°C tolerance	
					Min.	Max.	Min.	Max.
-40	1630.77	-6.623	1559.17	1705.49	-4.39	4.58	0.66	-0.69
-35	1178.11	-6.385	1130.05	1228.08	-4.08	4.24	0.64	-0.66
-30	860.97	-6.161	828.44	894.68	-3.78	3.92	0.61	-0.64
-25	636.08	-5.950	613.91	658.99	-3.49	3.60	0.59	-0.61
-20	474.78	-5.751	459.57	490.44	-3.20	3.30	0.56	-0.57
-15	357.83	-5.562	347.35	368.59	-2.93	3.01	0.53	-0.54
-10	272.18	-5.384	264.93	279.59	-2.66	2.73	0.49	-0.51
-5	208.83	-5.214	203.81	213.96	-2.41	2.45	0.46	-0.47
0	161.56	-5.053	158.08	165.10	-2.15	2.19	0.43	-0.43
5	125.97	-4.900	123.56	128.41	-1.91	1.94	0.39	-0.40
10	98.96	-4.755	97.30	100.63	-1.67	1.69	0.35	-0.36
15	78.29	-4.616	77.16	79.43	-1.44	1.45	0.31	-0.31
20	62.37	-4.483	61.61	63.13	-1.22	1.22	0.27	-0.27
25	50.00	-4.357	49.50	50.50	-1.00	1.00	0.23	-0.23
30	40.34	-4.236	39.85	40.83	-1.21	1.22	0.29	-0.29
35	32.73	-4.120	32.27	33.20	-1.42	1.43	0.34	-0.35
40	26.71	-4.009	26.28	27.15	-1.62	1.64	0.40	-0.41
45	21.92	-3.903	21.52	22.32	-1.81	1.84	0.46	-0.47
50	18.08	-3.801	17.72	18.45	-2.00	2.03	0.53	-0.53
55	14.99	-3.704	14.66	15.32	-2.19	2.22	0.59	-0.60
60	12.48	-3.610	12.19	12.78	-2.36	2.41	0.65	-0.67
65	10.44	-3.519	10.18	10.72	-2.54	2.59	0.72	-0.74
70	8.78	-3.433	8.54	9.02	-2.71	2.77	0.79	-0.81
75	7.41	-3.349	7.20	7.63	-2.87	2.95	0.86	-0.88
80	6.28	-3.269	6.09	6.48	-3.03	3.12	0.93	-0.95
85	5.34	-3.191	5.17	5.52	-3.19	3.28	1.00	-1.03
90	4.56	-3.117	4.41	4.72	-3.34	3.45	1.07	-1.11
95	3.91	-3.045	3.78	4.05	-3.49	3.61	1.15	-1.18
100	3.37	-2.975	3.24	3.49	-3.64	3.76	1.22	-1.26
105	2.91	-2.908	2.80	3.02	-3.78	3.92	1.30	-1.35
110	2.52	-2.843	2.42	2.62	-3.92	4.06	1.38	-1.43
115	2.19	-2.781	2.10	2.28	-4.05	4.21	1.46	-1.51
120	1.91	-2.720	1.83	1.99	-4.18	4.35	1.54	-1.60
125	1.67	-2.662	1.59	1.74	-4.31	4.50	1.62	-1.69
130	1.46	-2.605	1.40	1.53	-4.44	4.63	1.70	-1.78
135	1.28	-2.551	1.22	1.34	-4.56	4.77	1.79	-1.87
140	1.13	-2.498	1.08	1.19	-4.68	4.90	1.87	-1.96
145	1.00	-2.446	0.95	1.05	-4.80	5.03	1.96	-2.06
150	0.89	-2.396	0.84	0.93	-4.91	5.16	2.05	-2.15

# Components

## AS10S/L AS13S/L

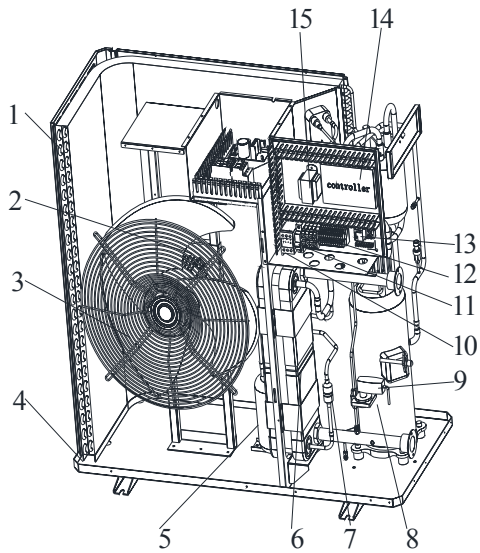

1. Finned coil heat exchanger
2. EC Fan motor
3. Fan blade
4. De-icing heater(option package 1)
5. Liquid receiver
6. Plate heat exchanger
7. Filter
8. Compressor
9. Differential pressure flow switch(option package 1)
10. Phase relay
11. Circuit breaker
12. Terminal block
13. Relay for pump
14. Carel controller
15. Transformer
16. Compressor contactor
17. Thermal overload relay
18. EC fan motor board
19. Economizer
20. EVI Expansion valve
21. Low pressure transducer
22. maincircuit Expansion valve
23. Service connection (LP)
24. Gas-liquid separator
25. Four way valve
26. High pressure transducer
27. Service connection (HP)

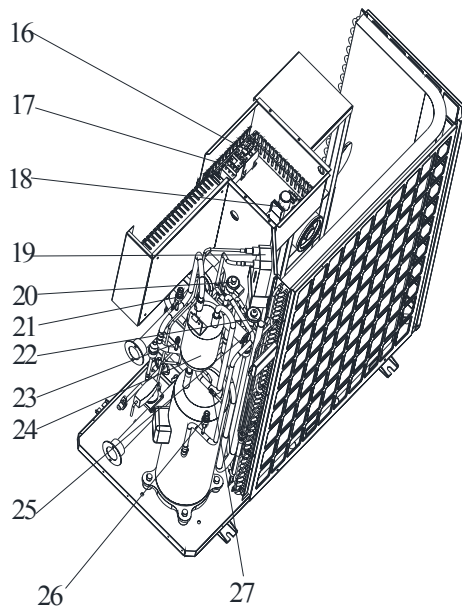

# Technical Specifications

AIR TO WATER HEAT PUMP		AS10S/L		AS13S/L		AS20S/L	
Heat output/Power consumption/COP at 7/35°C	kW	10.7/2.48	COP 4.31	14.85/3.5	COP 4.24	20.8/4.92	COP 4.22
Heat output/Power consumption/COP at 7/45°C*	kW	11.0/3.28	COP 3.35	14.96/4.6	COP 3.25	20.7/6.22	COP 3.33
Heat output/Power consumption/COP at 7/55°C*	kW	11.15/3.85	COP 2.88	15.23/5.45	COP 2.80	20.9/7.83	COP 2.67
Heat output/Power consumption/COP at 2/35°C	kW	8.9/2.68	COP 3.31	11.80/3.62	COP 3.26	16.4/4.91	COP 3.34
Heat output/Power consumption/COP at 2/45°C*	kW	9.0/3.35	COP 2.68	12.56/4.64	COP 2.70	16.5/6.25	COP 2.64
Heat output/Power consumption/COP at -7/35°C*	kW	7.98/2.64	COP 3.03	9.0/3.18	COP 2.83	14.3/4.58	COP 3.12
Heat output/Power consumption/COP at -7/45°C*	kW	8.1/3.28	COP 2.47	10.3/4.3	COP 2.39	14.5/5.73	COP 2.53
Heat output/Power consumption/COP at -10/35°C*	kW	7.28/2.65	COP 2.75	8.56/3.2	COP 2.67	14.2/5.14	COP 2.76
Heat output/Power consumption/COP at -10/45°C*	kW	7.35/3.32	COP 2.21	9.26/4.3	COP 2.15	14.1/6.4	COP 2.2
Heat output/Power consumption/COP at -15/35°C*	kW	6.35/2.68	COP 2.37	8.18/3.5	COP 2.34	12.4/5.21	COP 2.38
Heat output/Power consumption/COP at -15/45°C*	kW	6.4/3.29	COP 1.94	8.55/4.46	COP 1.92	12.5/6.38	COP 1.96
Cool output/Power consumption at 35/7°C	KW	8.26/2.9	COP 2.85	10.5/3.77	COP 2.78	17.8/6.3	COP 2.82
Rated current at A7/W35	A	4.9		6.9		9.7	
Starting current	A	53		75		74	
Power		380-415V/3PH/50Hz		380-420V/3PH/50Hz		380-415V/3PH/50Hz	
Compressor		HITACHI scroll		Copeland scroll		HITACHI scroll	
Condenser		Brazen plate heat exchanger					
Refrigerant R410A filling weight	kg	3.3		3.4		5.3	
Nominal flow heating medium	m <sup>3</sup> /h	1.82		2.32		3.58	
Internal pressure drop at nominal flow	kPa	16		18		36	
Air flow	m <sup>3</sup> /h	5000		5500		6000	
Nominal output fan	W	102		181		260	
Max outgoing heating medium temperature	°C	55					
Height	mm	1040				1048	
Width	mm	1096				1302	
Depth	mm	500 (+50 with foot)				695 (+45 with foot)	
Pipe connector		DN32				DN40	
Weight	kg	185		188		280	
Sound power level L <sub>WA</sub>	dB(A)	67		69		73	

The above data is tested by EN14511. 7/35°C means that :outdoor air temp.7°C, outlet water temp. 35°C

\*:EVI is operating