

# AREO S

fan heater for steam operation TECHNICAL MANUAL

GB



CE

COMPANY  
WITH QUALITY SYSTEM  
CERTIFIED BY DNV  
=ISO 9001/2000=

## INDEX

1	UNIT DESCRIPTION .....	2
2	CONSTRUCTIVE FEATURES .....	2
3	AVAILABLE OPTIONS .....	2
4	RATED TECHNICAL DATA .....	3
5	SOUND LEVELS .....	3
6	HEATING CAPACITY .....	4 - 6
7	HEIGHT OF INSTALLATION - WALL MOUNTING .....	7
8	HEIGHT OF INSTALLATION CEILING MOUNTING .....	7
9	OVERALL DIMENSIONS .....	8
10	ELECTRICAL DATA .....	9
11	WIRING DIAGRAMS .....	9
12	ACCESSORIES .....	10

DECLARATION OF CONFORMITY 

Galletti S.p.A. whose main office is located at 12/a via Romagnoli, 40010 Bentivoglio (BO) - Italy, hereby declares, under its own responsibility, that the fan heaters belonging to the AREO S series, indoor units for air-conditioning systems, conform to the specifications of **EEC** Directives 73/23, 89/392, 91/368, /93/44, 93/68, 89/336, 83/97 and subsequent modifications.

Bologna 30/06/2004

Luigi Galletti  
President

## OPERATING LIMITS

- thermal carrier fluid
- max steam pressure: 10 bar
- max steam temperature: 180°C
- Air inlet temperature: -10°C to +40°C
- Power supply: rated voltage +/- 10%

## 1 UNIT DESCRIPTION

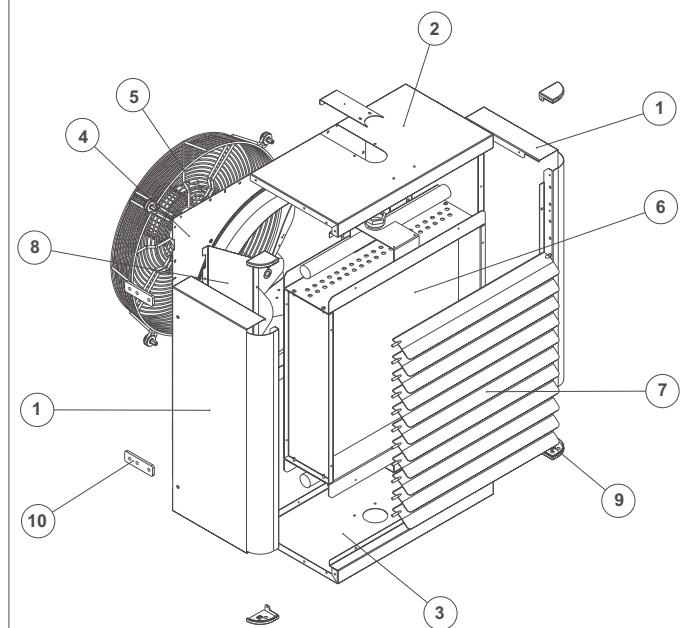

- (1) Cabinet: side panel
- (2) Cabinet: upper panel
- (3) Cabinet: lower panel
- (4) Rear panel/fan compartment
- (5) Safety grille (fan) supporting motor
- (6) Finned block heat exchanger (heat exchanger coil)
- (7) Adjustable louvers
- (8) Conveyor duct
- (9) Plastic corner trim on cabinet (left and right)
- (10) Wall/ceiling mounting brackets

## 2 CONSTRUCTIVE FEATURES

Gli aerotermini per funzionamento a vapore sono principalmente costituiti dai componenti elencati di seguito.

- > Prepainted sheet steel **cabinet** complete with heat-proof ABS corner trim. The cabinet is complete with **adjustable aluminium louvers** (spring operated) placed on the air outlet which allow an optimal distribution of the air within the heated room. They are supplied with brackets for suspending the fan heater to the ceiling or joining it to the mounting board for installation on the wall (accessory).
- > High conductivity **heat exchanger** made with copper tubes and aluminium fins assuring higher heat exchange than standard iron tubes exchangers. All circuit are in parallel without siphons to drain perfectly the condensed steam.
- > **All motors** are standard equipped with:
  - internal thermal protection (klixon)
  - windings in class F
  - protection degree IP55.
  - **Two speeds**, 4/6 poles or 6/8 poles, in the **400 / 3 / 50** version, delta-star type.
- > **Axial fan** with statically balanced sickle blades housed in a specially designed compartment that enhances ventilation and reduces noise emissions.
- > **Safety grille** made of electrogalvanised steel wire: it supports the motor and is fixed to the cabinet by means of vibration damping supports.

## 3 AVAILABLE OPTIONS

- CST** Delta/star selector for installation in electric panels
- CSTP** Delta/star selector with box for wall installation
- TA** Electromechanical room thermostat
- TA2** Wall mounted room thermostat with summer-winter selector
- DFP** Wall mounting board
- DFC** Column mounting board
- DFO** Adjustable wall/column mounting board
- PAE** Fresh air intake louver
- GR** Fresh air intake grille
- DO** Additional row of louvers
- R** Protection grill for gymnasium (against ball impact)

## 4 RATED TECHNICAL DATA

Model	Fan Speed	Air Flow	Heating Capacity	Steam Flow	Air Outlet Temperature	Max Installation Height	Sound Power	Weight
	rpm	m <sup>3</sup> /h	kW	kg	°C	m	dB A	kg
AREO S 12	4P	1150	12,00	20	51,0	3,0	66	19,4
	6P	700	8,92	15	57,9	3,0	62	
AREO S 22	4P	2600	24,50	40	48,0	3,5	69	25,1
	6P	1650	18,80	31	53,9	3,5	63	
AREO S 32	4P	4250	39,28	64	47,5	4,5	74	33,7
	6P	2700	30,19	49	53,2	4,0	65	
AREO S 42	4P	5900	55,40	90	47,9	4,5	77	39,1
	6P	3750	42,55	69	53,7	4,0	69	
AREO S 52	4P	8800	79,42	130	46,8	5,0	84	49,6
	6P	5600	61,18	100	52,5	4,0	73	
AREO S 62	6P	8100	92,65	151	54,0	5,5	77	58
	8P	6250	79,34	129	57,7	5,0	71	

Rated capacity determined at the following conditions:

Heating mode:

Steam pressure 1 bar (120°C), inlet air temperature 20°C

Sound pressure: distance of 5 meters, directional factor equal to 2

Fan speed:

4 p = 4 poles, 1400 rpm

6 p = 6 poles, 900 rpm

8 p = 8 poles, 700 rpm

## 5 SOUND LEVELS

Legend:

**Lp<sub>A</sub>** A - weighted sound pressure level (5m distance, 2 directional factor)

**Lw** Octave band sound power level

**Lw<sub>A</sub>** A - weighted sound power level

**Vr** Fan speed:

4 p = 4 poles, 1400 rpm

6 p = 6 poles, 900 rpm

8 p = 8 poles, 700 rpm

MODEL	Lw									
		125 Hz	250 Hz	500 Hz	1 kHz	2 kHz	4 kHz	8 kHz	Lw <sub>A</sub>	Lp <sub>A</sub>
	Vr	dB	dB	dB	dB	dB	dB	dB	dB/A	dB/A
AREO S 12	4P	61,9	63,1	61,8	61,3	59,1	56,2	49,6	66	44
	6P	62,0	58,5	59,3	56,5	55,2	51,1	43,6	62	40
AREO S 22	4P	64,9	66,1	64,8	64,3	62,1	59,2	52,6	69	47
	6P	63,0	59,5	60,3	57,5	56,2	52,1	44,6	63	41
AREO S 32	4P	69,9	71,1	69,8	69,3	67,1	64,2	57,6	74	52
	6P	65,0	61,5	62,3	59,5	58,2	54,1	46,6	65	43
AREO S 42	4P	72,9	74,1	72,8	72,3	70,1	67,2	60,6	77	55
	6P	69,0	65,5	66,3	63,5	62,2	58,1	50,6	69	47
AREO S 52	4P	80,7	83,2	78,2	78,7	77,8	74,1	66,6	84	62
	6P	69,7	72,2	67,2	67,7	66,8	63,1	55,6	73	51
AREO S 62	6P	73,7	76,2	71,2	71,7	70,8	67,1	59,6	77	55
	8P	67,7	66,9	65,5	65,7	65,3	61,8	52,5	71	49

The technical and dimensional data reported in this manual may be modified in view of any product improvement.

## 6 HEATING CAPACITY

### Legend:

- Ps** Steam pressure  
**PT** Heating capacity  
**Qa** Air flow  
**Qs** Steam flow rate  
**Tbs<sub>1</sub>** Outlet air temperature  
**Tbs<sub>2</sub>** Inlet air temperature  
**Ts** Steam temperature  
**Vr** Fan speed:  
**4 p** = 4 poles, 1400 rpm  
**6 p** = 6 poles, 900 rpm

Ps (Ts)	°C	0,1 bar (102°C)															
Tbs <sub>1</sub>	°C	0			10			15			20			25			
	Vr	Qa	PT	QS	Tbs <sub>2</sub>	PT	QS	Tbs <sub>2</sub>	PT	QS	Tbs <sub>2</sub>	PT	QS	Tbs <sub>2</sub>	PT	QS	Tbs <sub>2</sub>
		m <sup>3</sup> /h	kW	kg/h	°C	kW	kg/h	°C	kW	kg/h	°C	kW	kg/h	°C	kW	kg/h	°C
AREO S 12	1400	1150	12,4	20	29,9	11,1	18	37,8	10,5	17	41,6	9,9	16	45,5	9,2	15	49,2
	900	700	9,3	15	36,6	8,3	13	44,0	7,8	12	47,5	7,3	12	51,1	6,9	11	54,6
AREO S 22	1400	2600	25,3	40	27,0	22,7	36	35,1	21,4	34	39,1	20,1	32	43,0	18,8	30	46,9
	900	1650	19,5	31	32,7	17,4	28	40,3	16,4	26	44,1	15,4	25	47,8	14,5	23	51,5
AREO S 32	1400	4250	40,6	65	26,4	36,4	58	34,6	34,3	55	38,6	32,3	52	42,6	30,2	48	46,5
	900	2700	31,3	50	32,1	28,0	45	39,8	26,4	42	43,6	24,8	40	47,3	23,2	37	51,0
AREO S 42	1400	5900	57,2	91	26,9	51,3	82	35,0	48,4	77	39,0	45,5	73	42,9	42,6	68	46,8
	900	3750	44,1	70	32,5	39,5	63	40,2	37,2	59	44,0	35,0	56	47,7	32,7	52	51,4
AREO S 52	1400	8800	82,0	131	25,8	73,6	118	34,0	69,4	111	38,0	65,2	104	42,0	61,1	98	46,0
	900	5600	63,3	101	31,3	56,8	91	39,1	53,5	85	42,9	50,3	80	46,7	47,0	75	50,4
AREO S 62	900	8100	96,0	153	32,8	86,0	137	40,5	81,0	129	44,2	76,1	122	47,9	71,2	114	51,6
	700	6250	82,3	131	36,5	73,7	118	43,8	69,4	111	47,4	65,2	104	51,0	61,0	97	54,5

Ps (Ts)	°C	0,5 bar (111°C)															
Tbs <sub>1</sub>	°C	0			10			15			20			25			
	Vr	Qa	PT	QS	Tbs <sub>2</sub>	PT	QS	Tbs <sub>2</sub>	PT	QS	Tbs <sub>2</sub>	PT	QS	Tbs <sub>2</sub>	PT	QS	Tbs <sub>2</sub>
		m <sup>3</sup> /h	kW	kg/h	°C	kW	kg/h	°C	kW	kg/h	°C	kW	kg/h	°C	kW	kg/h	°C
AREO S 12	1400	1150	13,51	22	32,5	12,22	20	40,5	11,58	19	44,4	10,94	18	48,3	10,31	17	52,1
	900	700	10,07	16	39,8	9,09	15	47,3	8,61	14	50,9	8,13	13	54,5	7,65	12	58,0
AREO S 22	1400	2600	27,55	44	29,3	24,93	40	37,5	23,63	38	41,5	22,34	36	45,5	21,05	34	49,5
	900	1650	21,19	34	35,6	19,15	31	43,3	18,14	29	47,1	17,14	28	50,9	16,14	26	54,6
AREO S 32	1400	4250	44,16	71	28,8	39,96	65	37,0	37,88	61	41,0	35,81	58	45,0	33,75	54	49,0
	900	2700	34,02	55	34,9	30,75	50	42,7	29,13	47	46,5	27,52	44	50,3	25,92	42	54,0
AREO S 42	1400	5900	62,29	101	29,2	56,37	91	37,4	53,43	86	41,4	50,51	82	45,4	47,60	77	49,4
	900	3750	47,96	77	35,4	43,35	70	43,2	41,06	66	47,0	38,79	63	50,7	36,53	59	54,4
AREO S 52	1400	8800	89,26	144	28,1	80,79	130	36,3	76,59	124	40,4	72,41	117	44,4	68,25	110	48,4
	900	5600	68,93	111	34,1	62,31	101	41,9	59,04	95	45,8	55,78	90	49,6	52,54	85	53,4
AREO S 62	900	8100	104,45	169	35,7	94,39	152	43,4	89,41	144	47,2	84,47	136	51,0	79,55	128	54,7
	700	6250	89,59	145	39,7	80,90	131	47,1	76,60	124	50,8	72,33	117	54,4	68,09	110	57,9

Ps (Ts)	°C	1 bar (120°C)															
Tbs <sub>1</sub>	°C	0			10			15			20			25			
	Vr	Qa	PT	QS	Tbs <sub>2</sub>	PT	QS	Tbs <sub>2</sub>	PT	QS	Tbs <sub>2</sub>	PT	QS	Tbs <sub>2</sub>	PT	QS	Tbs <sub>2</sub>
		m <sup>3</sup> /h	kW	kg/h	°C	kW	kg/h	°C	kW	kg/h	°C	kW	kg/h	°C	kW	kg/h	°C
AREO S 12	1400	1150	14,58	24	35,1	13,28	22	43,1	12,64	21	47,1	12,00	20	51,0	11,36	19	54,9
	900	700	10,87	18	43,0	9,89	16	50,5	9,40	15	54,2	8,92	15	57,9	8,44	14	61,4
AREO S 22	1400	2600	29,74	49	31,7	27,11	44	39,9	25,80	42	44,0	24,50	40	48,0	23,21	38	52,0
	900	1650	22,87	37	38,4	20,82	34	46,2	19,81	32	50,1	18,80	31	53,9	17,80	29	57,6
AREO S 32	1400	4250	47,67	78	31,0	43,45	71	39,3	41,36	67	43,4	39,28	64	47,5	37,21	61	51,5
	900	2700	36,72	60	37,7	33,44	55	45,5	31,81	52	49,4	30,19	49	53,2	28,58	47	57,0
AREO S 42	1400	5900	67,24	110	31,5	61,29	100	39,8	58,34	95	43,9	55,40	90	47,9	52,48	86	51,9
	900	3750	51,77	84	38,2	47,13	77	46,1	44,83	73	49,9	42,55	69	53,7	40,28	66	57,5
AREO S 52	1400	8800	96,35	157	30,3	87,84	143	38,6	83,62	136	42,8	79,42	130	46,8	75,25	123	50,8
	900	5600	74,40	121	36,8	67,75	111	44,7	64,46	105	48,6	61,18	100	52,5	57,93	95	56,3
AREO S 62	900	8100	112,74	184	38,5	102,63	167	46,4	97,63	159	50,2	92,65	151	54,0	87,71	143	57,7
	700	6250	96,71	158	42,8	87,96	144	50,4	83,63	136	54,1	79,34	129	57,7	75,07	122	61,3

## 6 HEATING CAPACITY

### Legend:

- Ps** Steam pressure  
**PT** Heating capacity  
**Qa** Air flow  
**Qs** Steam flow rate  
**Tbs<sub>1</sub>** Outlet air temperature  
**Tbs<sub>2</sub>** Inlet air temperature  
**Ts** Steam temperature  
**Vr** Fan speed:  
**4 p** = 4 poles, 1400 rpm  
**6 p** = 6 poles, 900 rpm

Ps (Ts)		2 bar (133°C)																
Tbs <sub>1</sub>	°C	0			10			15			20			25				
	Vr	Qa	PT	QS	Tbs <sub>2</sub>	PT	QS	Tbs <sub>2</sub>	PT	QS	Tbs <sub>2</sub>	PT	QS	Tbs <sub>2</sub>	PT	QS	Tbs <sub>2</sub>	
		m <sup>3</sup> /h	kW	kg/h	°C	kW	kg/h	°C	kW	kg/h	°C	kW	kg/h	°C	kW	kg/h	°C	
AREO S 12	1400	1150	16,20	27	39,0	14,89	25	47,2	14,25	24	51,2	13,60	23	55,1	12,96	22	59,1	
	900	700	12,08	20	47,8	11,09	18	55,5	10,60	18	59,2	10,11	17	62,9	9,62	16	66,6	
AREO S 22	1400	2600	33,05	55	35,2	30,40	50	43,6	29,08	48	47,7	27,78	46	51,7	26,47	44	55,8	
	900	1650	25,42	42	42,6	23,35	39	50,6	22,33	37	54,5	21,31	35	58,4	20,30	34	62,2	
AREO S 32	1400	4250	52,97	88	34,5	48,73	81	42,9	46,63	77	47,0	44,53	74	51,1	42,45	70	55,2	
	900	2700	40,81	68	41,8	37,49	62	49,9	35,85	60	53,8	34,22	57	57,7	32,60	54	61,5	
AREO S 42	1400	5900	74,71	124	35,1	68,72	114	43,4	65,75	109	47,5	62,80	104	51,6	59,86	99	55,7	
	900	3750	57,53	95	42,5	52,85	88	50,4	50,53	84	54,4	48,23	80	58,2	45,94	76	62,0	
AREO S 52	1400	8800	107,06	178	33,7	98,50	163	42,1	94,26	156	46,3	90,03	149	50,4	85,83	142	54,5	
	900	5600	82,68	137	40,9	75,97	126	48,9	72,65	121	52,9	69,35	115	56,8	66,08	110	60,7	
AREO S 62	900	8100	125,28	208	42,8	115,09	191	50,8	110,04	183	54,7	105,02	174	58,5	100,04	166	62,3	
	700	6250	107,46	178	47,6	98,63	164	55,3	94,27	156	59,0	89,93	149	62,8	85,63	142	66,4	

Ps (Ts)		4 bar (151°C)																
Tbs <sub>1</sub>	°C	0			10			15			20			25				
	Vr	Qa	PT	QS	Tbs <sub>2</sub>	PT	QS	Tbs <sub>2</sub>	PT	QS	Tbs <sub>2</sub>	PT	QS	Tbs <sub>2</sub>	PT	QS	Tbs <sub>2</sub>	
		m <sup>3</sup> /h	kW	kg/h	°C	kW	kg/h	°C	kW	kg/h	°C	kW	kg/h	°C	kW	kg/h	°C	
AREO S 12	1400	1150	18,42	31	44,3	17,10	29	52,7	16,44	28	56,8	15,79	27	60,8	15,15	26	64,8	
	900	700	13,73	23	54,3	12,71	22	62,1	12,22	21	66,0	11,74	20	69,8	11,25	19	73,6	
AREO S 22	1400	2600	37,57	64	40,0	34,90	59	48,5	33,57	57	52,7	32,25	55	56,9	30,94	53	61,0	
	900	1650	28,90	49	48,5	26,81	46	56,6	25,77	44	60,6	24,74	42	64,6	23,72	40	68,4	
AREO S 32	1400	4250	60,22	102	39,2	55,94	95	47,8	53,82	92	52,0	51,71	88	56,1	49,60	84	60,3	
	900	2700	46,40	79	47,6	43,05	73	55,8	41,39	70	59,8	39,73	78	63,7	38,10	65	67,6	
AREO S 42	1400	5900	84,94	145	39,9	78,90	134	48,4	75,90	129	52,6	72,92	124	56,7	69,96	119	60,8	
	900	3750	65,41	111	48,3	60,68	103	56,4	58,33	99	60,3	56,01	95	64,4	53,69	91	68,3	
AREO S 52	1400	8800	121,72	207	38,3	113,09	192	46,9	108,81	185	51,1	104,54	178	55,3	100,30	171	59,4	
	900	5600	94,00	160	46,5	87,20	148	54,7	83,87	143	58,7	80,53	137	62,6	77,22	131	66,6	
AREO S 62	900	8100	142,44	242	48,7	132,13	225	56,8	127,03	216	60,8	121,95	208	64,7	116,92	199	68,6	
	700	6250	122,18	208	54,1	113,24	193	62,0	108,82	185	65,8	104,43	178	69,6	100,07	170	73,4	

Ps (Ts)		6 bar (164°C)																
Tbs <sub>1</sub>	°C	0			10			15			20			25				
	Vr	Qa	PT	QS	Tbs <sub>2</sub>	PT	QS	Tbs <sub>2</sub>	PT	QS	Tbs <sub>2</sub>	PT	QS	Tbs <sub>2</sub>	PT	QS	Tbs <sub>2</sub>	
		m <sup>3</sup> /h	kW	kg/h	°C	kW	kg/h	°C	kW	kg/h	°C	kW	kg/h	°C	kW	kg/h	°C	
AREO S 12	1400	1150	20,02	35	48,2	18,69	32	56,6	18,03	31	60,8	17,37	30	64,9	16,72	29	68,9	
	900	700	14,92	26	59,0	13,91	24	67,0	13,41	23	70,9	12,91	22	74,8	12,40	21	78,4	
AREO S 22	1400	2600	40,83	71	43,5	38,14	66	52,1	36,80	64	56,3	35,48	62	60,5	34,15	59	64,7	
	900	1650	31,40	55	52,7	29,30	51	61,0	28,25	49	65,0	27,22	47	69,0	26,19	45	73,0	
AREO S 32	1400	4250	65,44	114	42,6	61,13	106	51,3	59,00	102	55,5	56,87	99	59,8	54,76	95	63,9	
	900	2700	50,42	88	51,7	47,04	82	60,0	45,37	79	64,0	43,71	76	68,1	42,05	73	72,0	
AREO S 42	1400	5900	92,31	160	43,3	86,23	150	51,9	83,21	144	56,2	80,21	139	60,4	77,22	134	64,6	
	900	3750	71,08	123	52,5	66,31	115	60,7	63,95	111	64,8	61,60	107	68,8	59,27	103	72,7	
AREO S 52	1400	8800	132,28	230	41,6	123,59	215	50,3	119,28	207	54,6	114,99	200	58,8	110,72	192	62,0	
	900	5600	102,15	177	50,5	95,32	166	58,9	91,94	160	63,0	88,58	154	67,0	85,24	148	71,0	
AREO S 62	900	8100	154,79	269	52,9	144,40	251	61,2	139,25	242	65,2	134,14	233	69,2	129,06	224	73,2	
	700	6250	132,77	231	58,8	123,75	215	66,8	119,29	207	70,7	114,86	199	74,6	110,47	192	78,4	

## 6 HEATING CAPACITY

### Legend:

- Ps** Steam pressure  
**PT** Heating capacity  
**Qa** Air flow  
**Qs** Steam flow rate  
**Tbs<sub>1</sub>** Outlet air temperature  
**Tbs<sub>2</sub>** Inlet air temperature  
**Ts** Steam temperature  
**Vr** Fan speed:  
**4 p** = 4 poles, 1400 rpm  
**6 p** = 6 poles, 900 rpm

Ps (Ts)	°C	8 bar (175°C)															
Tbs <sub>1</sub>	°C	0			10			15			20			25			
	Vr	Qa	PT	QS	Tbs <sub>2</sub>	PT	QS	Tbs <sub>2</sub>	PT	QS	Tbs <sub>2</sub>	PT	QS	Tbs <sub>2</sub>	PT	QS	Tbs <sub>2</sub>
		m <sup>3</sup> /h	kW	kg/h	°C	kW	kg/h	°C	kW	kg/h	°C	kW	kg/h	°C	kW	kg/h	°C
AREO S 12	1400	1150	21,27	38	51,2	19,94	35	59,7	19,27	34	63,9	18,61	33	68,1	17,96	32	72,2
	900	700	15,86	28	62,7	14,84	26	70,8	14,33	25	74,7	13,84	24	78,7	13,33	24	82,6
AREO S 22	1400	2600	43,39	77	46,2	40,69	72	54,9	39,34	69	59,2	38,01	67	63,4	36,68	65	67,6
	900	1650	33,37	59	56,0	31,25	55	64,4	30,20	53	68,5	29,16	52	72,5	28,12	50	76,5
AREO S 32	1400	4250	69,55	123	45,3	65,22	115	54,0	63,07	111	58,3	60,94	108	62,6	58,81	104	66,8
	900	2700	53,58	95	54,9	50,18	89	63,3	48,50	86	67,5	46,83	83	71,5	45,17	80	75,6
AREO S 42	1400	5900	98,10	173	46,0	91,99	162	54,7	88,95	157	59,0	85,94	152	63,0	82,94	146	67,5
	900	3750	75,53	133	55,8	70,74	125	64,1	68,36	121	68,2	66,00	117	72,3	63,66	112	76,3
AREO S 52	1400	8800	140,57	248	44,2	131,85	233	53,0	127,51	225	57,3	123,20	218	61,6	118,91	210	65,8
	900	5600	108,56	192	53,7	101,69	180	62,1	98,29	174	66,3	94,91	168	70,4	91,55	162	74,3
AREO S 62	900	8100	164,50	291	56,2	154,04	272	64,6	148,87	263	68,7	143,72	254	72,7	138,61	245	76,7
	700	6250	141,10	249	62,5	132,02	233	70,6	127,53	225	74,6	123,07	217	78,5	118,64	210	82,4

Ps (Ts)	°C	10 bar (184°C)															
Tbs <sub>1</sub>	°C	0			10			15			20			25			
	Vr	Qa	PT	QS	Tbs <sub>2</sub>	PT	QS	Tbs <sub>2</sub>	PT	QS	Tbs <sub>2</sub>	PT	QS	Tbs <sub>2</sub>	PT	QS	Tbs <sub>2</sub>
		m <sup>3</sup> /h	kW	kg/h	°C	kW	kg/h	°C	kW	kg/h	°C	kW	kg/h	°C	kW	kg/h	°C
AREO S 12	1400	1150	22,33	40	53,8	20,99	38	62,4	20,32	36	66,6	19,66	35	70,8	19,00	34	74,9
	900	700	16,65	30	65,9	15,62	28	74,1	15,12	27	78,2	14,61	26	82,0	14,11	25	85,9
AREO S 22	1400	2600	45,55	82	48,5	42,84	77	57,3	41,49	74	61,6	40,15	72	65,9	38,82	70	70,1
	900	1650	35,04	63	58,8	32,91	59	67,2	31,85	57	71,4	30,80	55	75,5	29,76	53	79,5
AREO S 32	1400	4250	73,01	131	47,6	68,67	123	56,4	66,51	119	60,7	64,37	115	65,0	62,23	112	69,3
	900	2700	56,25	101	57,7	52,84	95	66,2	51,15	92	70,3	49,47	89	74,4	47,80	86	78,5
AREO S 42	1400	5900	102,99	185	48,3	96,85	174	57,1	93,81	168	61,4	90,78	163	65,7	87,76	157	70,0
	900	3750	79,30	142	58,5	74,48	134	67,0	72,09	129	71,1	69,72	125	75,2	67,38	121	79,3
AREO S 52	1400	8800	147,58	265	46,4	138,82	249	55,3	134,47	241	59,6	130,14	233	63,9	125,84	226	68,2
	900	5600	113,97	204	56,3	107,07	192	64,9	103,65	186	69,1	100,25	180	73,2	96,88	174	77,3
AREO S 62	900	8100	172,70	310	59,0	162,19	291	67,5	156,99	282	71,6	151,81	272	75,7	146,68	263	79,7
	700	6250	148,13	266	65,6	139,00	249	73,8	134,48	241	77,8	130,00	233	81,8	125,55	225	85,7

### 7 HEIGHT OF INSTALLATION WALL MOUNTING

**Legend:**

- 4 p** 4 poles, 1400 rpm
- 6 p** 6 poles, 900 rpm
- Hv** maximum installation height
- Ao** throw distance
- Bo** floor influence area

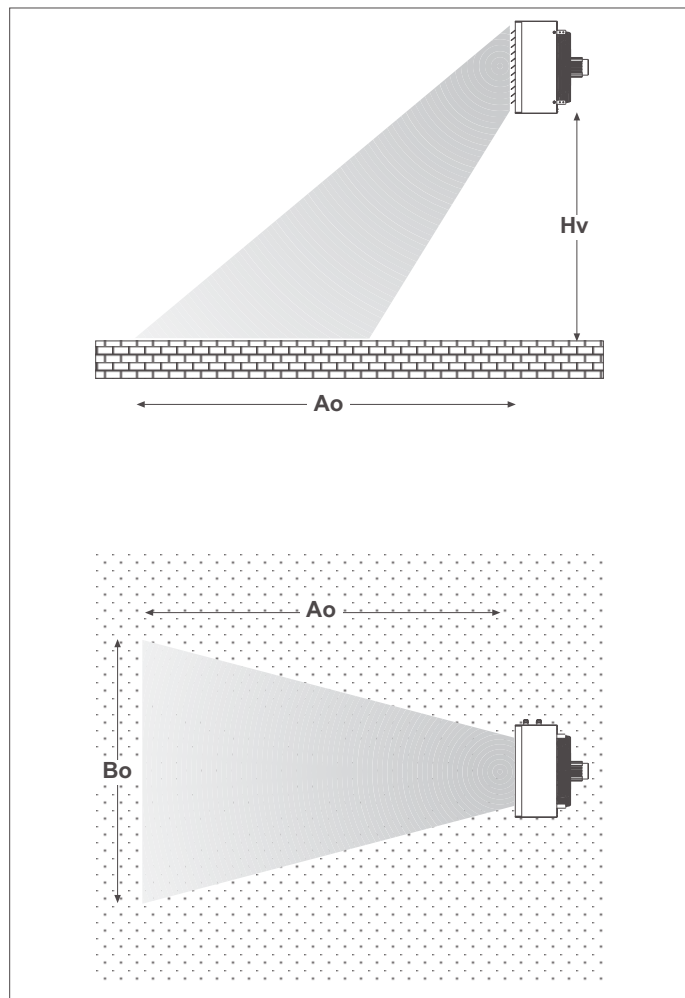

### 8 HEIGHT OF INSTALLATION CEILING MOUNTING

**Legend:**

- 4 p** 4 poles, 1400 rpm
- 6 p** 6 poles, 900 rpm
- Ho** maximum installation height
- Ao** floor influence area
- Bo** floor influence area

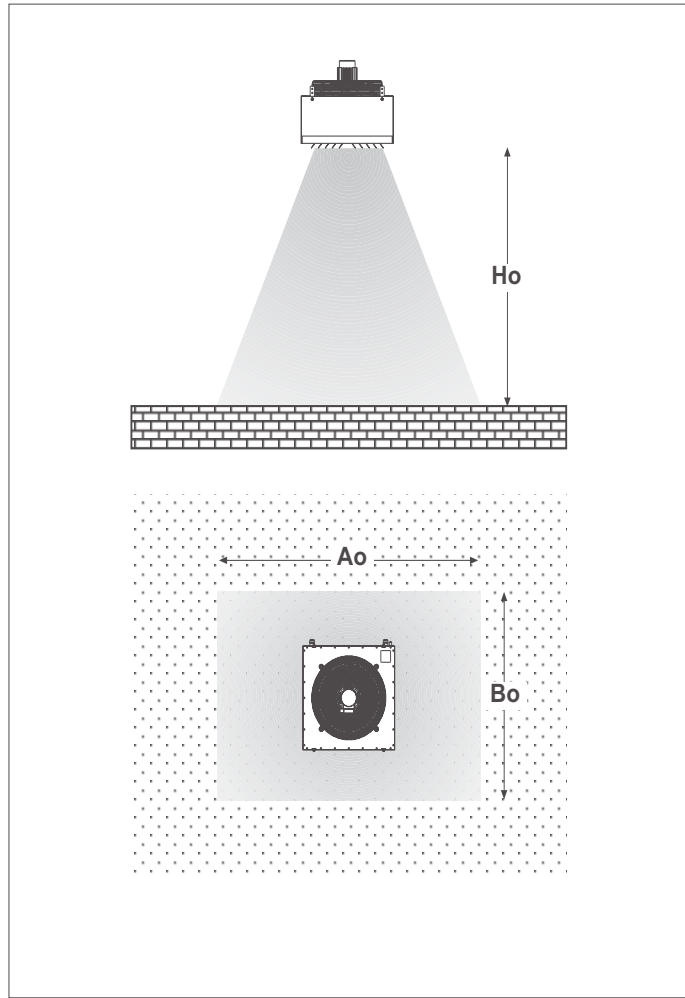

	4 P			6 P		
	Ho	Ao	Bo	Ho	Ao	Bo
	m	m	m	m	m	m
<b>AREO S 12</b>	3,0	7,0	5,5	3,0	5,0	3,0
<b>AREO S 22</b>	3,5	11,0	7,0	3,5	7,5	5,0
<b>AREO S 32</b>	4,5	15,5	8,0	4,0	9,5	6,0
<b>AREO S 42</b>	4,5	19,0	8,0	4,0	11,5	6,5
<b>AREO S 52</b>	5,0	19,0	10,0	4,5	12,0	8,0
<b>AREO S 62</b>	-	-	-	5,5	12,5	8,0

	4 P			6 P		
	Ho	Ao	Bo	Ho	Ao	Bo
	m	m	m	m	m	m
<b>AREO S 12</b>	3,5	7,5	4,0	2,5	4,0	2,5
<b>AREO S 22</b>	4,0	8,5	5,0	3,5	6,0	3,5
<b>AREO S 32</b>	5,0	10,5	6,0	4,0	7,5	5,0
<b>AREO S 42</b>	5,5	12,0	7,0	4,0	8,5	5,5
<b>AREO S 52</b>	6,0	14,0	9,0	5,5	10,0	6,5
<b>AREO S 62</b>	-	-	-	6,0	11,0	7,0

9 OVERALL DIMENSIONS

AREO S Basic version

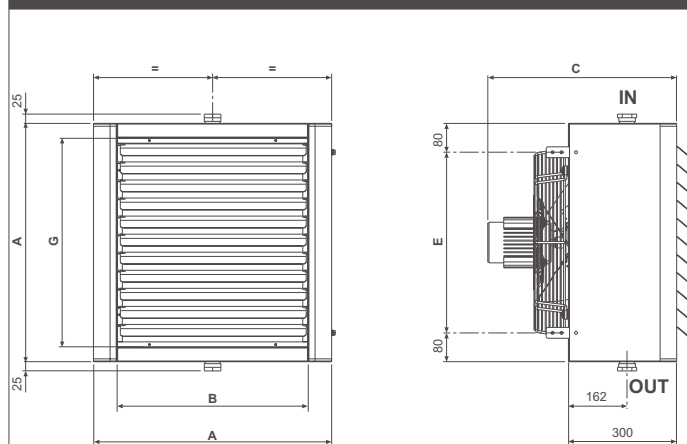

Legend:

**IN** Inlet connection (1" 1/4 female gas coupling)  
**OUT** Outlet connection (1" 1/4 female gas coupling)

	A (mm)	B (mm)	C (mm)	E (mm)	G (mm)
AREO S 12	460	330	500	328	300
AREO S 22	560	430	500	428	400
AREO S 32	660	530	525	528	500
AREO S 42	760	630	515	628	600
AREO S 52	860	730	535	728	700
AREO S 62	960	830	535	828	800

PAE Fresh air intake

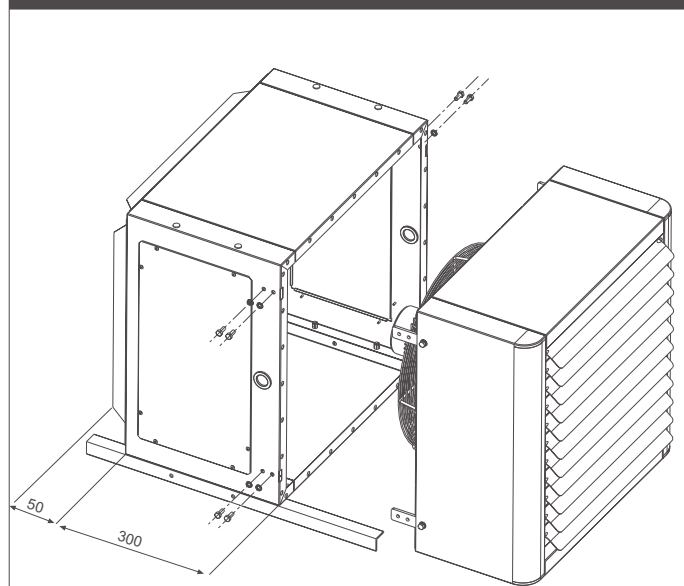

PAE	Model	air inlet	hole in the wall
AYPAE1	AREO S 12	392 X 392	400 x 400
AYPAE2	AREO S 22	492 x 492	500 x 500
AYPAE3	AREO S 32	592 x 592	600 x 600
AYPAE4	AREO S 42	692 x 692	700 x 700
AYPAE5	AREO S 52	792 x 792	800 x 800
AYPAE6	AREO S 62	892 x 892	900 x 900

GR Outdoor air intake grille

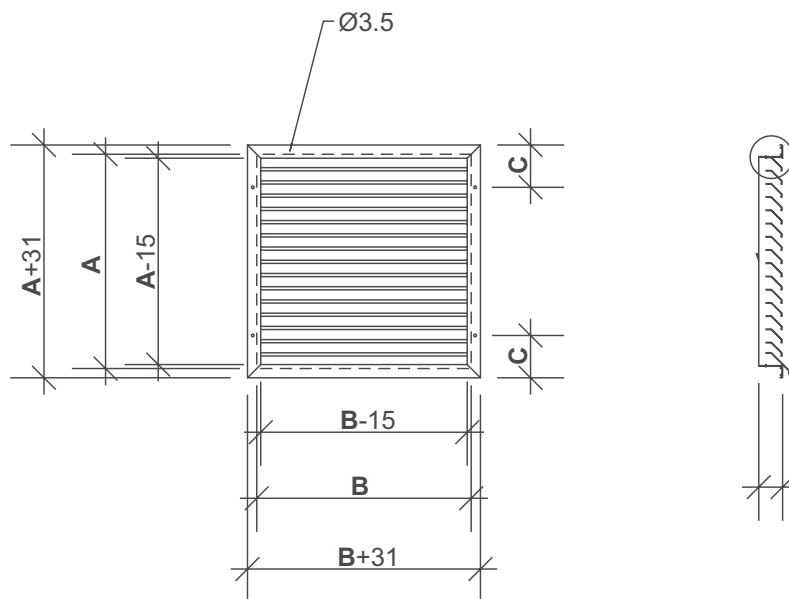

GR	Modello	A (mm)	B (mm)	C (mm)
AYGR1	AREO S 12	400	400	80
AYGR2	AREO S 22	500	500	80
AYGR3	AREO S 32	600	600	80
AYGR4	AREO S 42	700	700	80
AYGR5	AREO S 52	800	800	80
AYGR6	AREO S 62	900	900	80



## 10 ELECTRICAL DATA

Features of the standard motor:

- tropicalised
- equipped internally with a thermal cutout
- IP 55 protection degree
- class F winding
- closed type: asynchronous three-phase 2-speed motors (400/400 V star-delta connection).

400/400 V - YΔ motors are equipped internally with a thermal cutout and speeds are selected by means of a normal star-delta switch (accessory CST).

The terminals of the cutouts are connected to the terminal block so that they can be used as protection in series with the coil of a contactor.

If the internal cutout is not used to protect the motor, it will be necessary to provide a motor overload cutout set at a current that is 10-15% higher than the current indicated on the unit rating plate.

Make the electrical connections with the power supply disconnected, in accordance with current safety regulations. All the wiring must be done by qualified personnel.

Check that the mains electricity supply is compatible with the voltage shown on the unit rating plate.

Scrupulously follow the wiring diagram provided, according to the type of installation.

Each unit requires a switch (IL) on the feeder line with a distance of at least 3 mm between the opening contacts, and a suitable safety fuse (F).

Model	Number of poles	Fan Revolution	Voltage	Power Input	Current Absorbed
		rpm	V	W	A
AREO S 12	4/6	1400 / 900	400	67 / 46	0,209 / 0,118
AREO S 22	4/6	1400 / 900	400	277 / 172	0,61 / 0,32
AREO S 32	4/6	1400 / 900	400	394 / 294	0,85 / 0,58
AREO S 42	4/6	1400 / 900	400	703 / 471	1,49 / 0,85
AREO S 52	4/6	1400 / 900	400	1300 / 860	2,49 / 1,37
AREO S 62	6/8	900 / 700	400	540 / 417	1,18 / 0,69

## 11 WIRING DIAGRAMS

Delta connection to terminal block of 400/400 V - YΔ motors, high speed

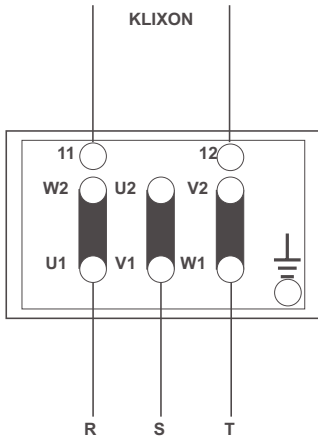

Star connection to terminal block of 400/400 V - YΔ motors, low speed

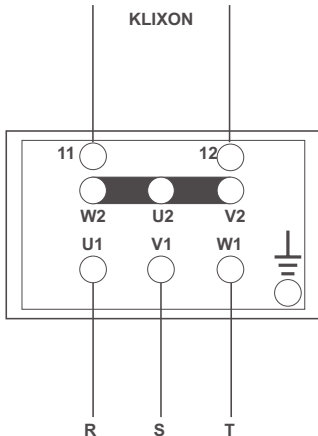

Wiring diagram showing connection of 400/400 V motor, with star-delta selector (YΔ).

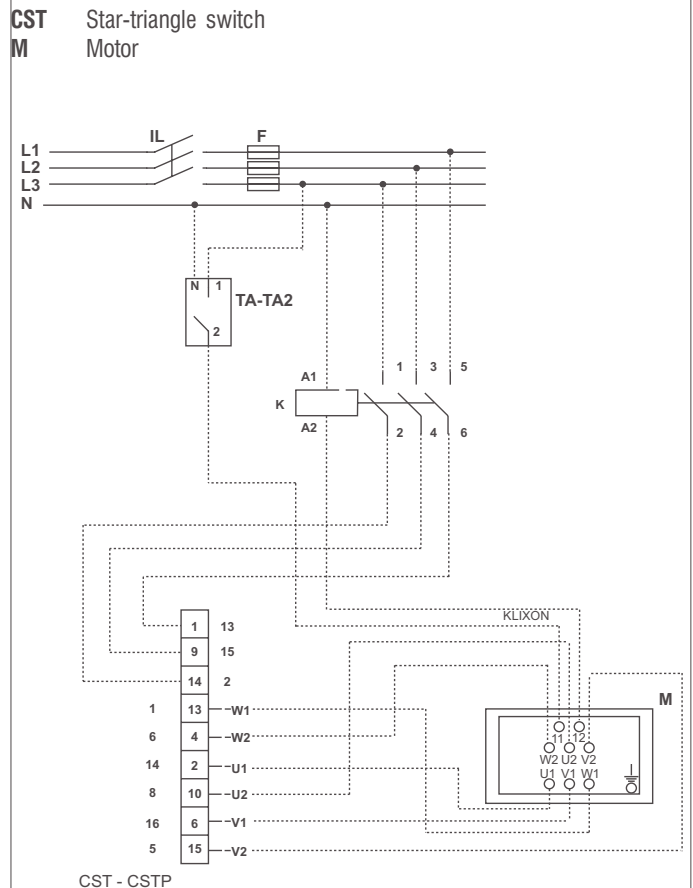

## 12 ACCESSORIES

### TA - Wall mounted room thermostat

Automatic regulation of the the room temperature:

- only in the heating mode working on the fan motor assembly;
- only in the cooling mode working on the fan motor assembly;
- both in cooling and heating mode, with remote mode selection working on the fan motor assembly.



### TA2 - Wall mounted room thermostat with summer-winter selector

Wall mounted room thermostat with cooling/heating mode selector.

Automatic regulation of the room temperature both in heating and cooling mode, working on the fan motor assembly.



### CST -Delta/star selector for installation in electric panels

Allows the rotational speed switching (off / low-speed / high-speed). For electrical box installation.

### CSTP - Delta/star selector with box for wall installation

Allows the rotational speed switching (off / low-speed / high-speed). Supplied with plastic box for wall installation.

### PAE - Fresh air intake louver

Allows the fresh air intake from the outside. Usually installed together with the outdoor fresh-air intake grill (GR option)



### GR - Outdoor air intake grille

Galvanised aluminium outdoor fresh-air intake grill. Equipped with anti-intrusion grill, in order to avoid the intrusion of dangerous objects from the outside.

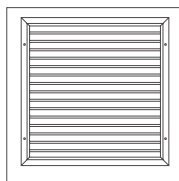

### DFP - wall mounting board

The DFP option (made in steel of adequate thickness) allows the installation on indoor walls. The fan heater is connected to the wall mounting board by mean of the four tongues in the back panel of the unit (connection screws supplied).

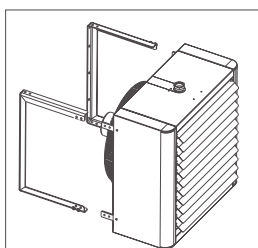

### DFC - column mounting board

The DFC option (made in steel of adequate thickness) allows the installation on indoor columns or walls. The fan heater is connected to the wall mounting board by mean of the four tongues in the back panel of the unit (connection and option mounting screws supplied).

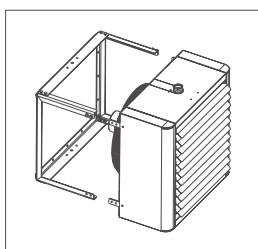

### DFO - Adjustable wall/column mounting board

The DFO option (made in steel of adequate thickness) allows to orient the fan heater as needed (towards left or right), during the installation on indoor columns or walls. The fan heater is connected to the wall mounting board by mean of the four brackets in the back panel of the unit (connection and option mounting screws supplied).

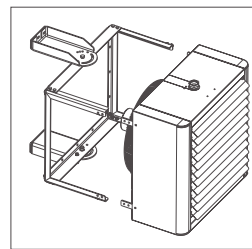

### R - Protection grill for gymnasium

Protection grill for gymnasium (against ball impact on adjustable louvers). Option mounting screws supplied.

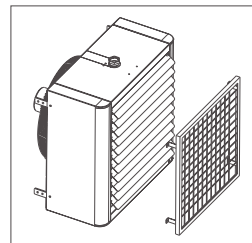

### DO - Additional row of louvers

The additional row of louvers air diffuser allows to orient the air flow on the horizontal plane, towards left or right. Option mounting screws supplied.







40010 Bentivoglio (BO)  
Via Romagnoli, 12/a  
Tel. 051/8908111  
Fax 051/8908122  
[www.galletti.it](http://www.galletti.it)