

# WALL MOUNTED AND CEILING WALL SPLIT SYSTEMS

# PERFORMANCE DATA

## C O N T E N T S

1. SPECIFICATIONS .....	1
2. DIMENSIONAL OUTLINE DRAWING .....	3
3. CIRCUIT DIAGRAM .....	6
4. REMOTE CONTROL UNIT .....	11
5. REFRIGERANT CYCLE .....	12
6. REFRIGERANT CHARGING .....	16
7. TEMPERATURE RANGE .....	17
8. AIR VELOCITY DISTRIBUTION .....	18
9. PERFORMANCE CURVE .....	20
10. NOISE LEVEL MEASUREMENT .....	23

# 1. SPECIFICATIONS

## 1.1 WALL MOUNTED TYPE (AS MODEL)

TYPE		COOLING			COOLING & HEATING			
MODEL	INDOOR	AS□18ABA-W	AS□24ABA-W	AS□30ABA-W	AS□18RBA-W	AS□24RBA-W	AS□30RBA-W	
	OUTDOOR	AO□18ANE	AO□24AME	AO□30AMAL	AO□18RMEL	AO□24RMEL	AO□30RMAL	
POWER SOURCE		V/φ/Hz	220 - 240 / 1 / 50					
CAPACITY	COOLING	kW	5.30 - 5.40	6.80 - 6.90	8.05 - 8.20	5.30 - 5.40	6.80 - 6.90	7.80 - 8.00
		BTU/h	18,100 - 18,400	23,200 - 23,600	27,500 - 28,000	18,100 - 18,400	23,200 - 23,600	26,600 - 27,300
	HEATING	kW	—	—	—	5.50 - 5.60	7.70 - 7.80	8.55 - 8.80
		BTU/h	—	—	—	18,800 - 19,100	26,300 - 26,600	29,200 - 30,000
RUNNING CURRENT	COOLING	A	8.4 - 8.0	12.2 - 11.3	13.8 - 13.7	8.8 - 8.5	11.9 - 11.1	13.7 - 13.5
	HEATING		—	—	—	7.8 - 7.7	12.1 - 11.4	14.5 - 14.4
POWER CONSUMPTION	COOLING	kW	1.84 - 1.89	2.61 - 2.65	2.96 - 3.08	1.89 - 1.98	2.60 - 2.65	2.93 - 3.05
	HEATING		—	—	—	1.70 - 1.80	2.64 - 2.72	3.13 - 3.25
STARTING CURRENT		A	43	56	90	52	56	90
MOISTURE REMOVAL		ℓ/h (pints/h)	2.0 (4.3)	2.5 (5.3)	3.0 (6.4)	2.0 (4.3)	2.5 (5.3)	3.0 (6.4)
E.E.R.	COOLING	kW/kW	2.88 - 2.86	2.61 - 2.60	2.72 - 2.66	2.80 - 2.73	2.62 - 2.60	2.66 - 2.62
	HEATING		—	—	—	3.24 - 3.11	2.92 - 2.87	2.73 - 2.71
FAN SPEED (r.p.m.)	INDOOR	HIGH	1,080	1,190	1,320	1,080	1,190	1,320
		MED	940	1,030	1,210	940	1,030	1,210
		LOW	810	900	1,030	810	900	1,030
	OUTDOOR		735	735	730	735	735	730
AIR FLOW	INDOOR	m <sup>3</sup> /h (C.F.M.)	900 (530)	1,000 (590)	1,100 (650)	900 (530)	1,000 (590)	1,100 (650)
	OUTDOOR		2,590 (1,520)		3,320 (1,950)	2,590 (1,520)		3,320 (1,950)
SOUND PRESSURE LEVEL (dB)	INDOOR	HIGH	41	44	47	41	44	47
		MED	36	40	44	36	40	44
		LOW	33	35	40	33	35	40
	OUTDOOR		55			55		56
DIMENSIONS H x W x D (mm)	NET	INDOOR	320 x 1,120 x 220					
		OUTDOOR	643 x 840 x 336		900 x 900 x 350	643 x 840 x 336		900 x 900 x 350
	GROSS	INDOOR	348 x 1,240 x 427					
		OUTDOOR	750 x 959 x 429		1,045 x 1,025 x 445	750 x 959 x 429		1,045 x 1,025 x 445
WEIGHT [NET/GROSS]	INDOOR	kg (lbs)	16 (35) / 22 (49)					
	OUTDOOR		59(130) / 67(148)	65(143) / 73(161)	79(174) / 91(200)	68(150) / 76(168)	69(152) / 77(169)	80(176) / 92(202)
CONNECTION PIPE SIZE (mm)		SMALL/LARGE	φ9.52 / φ15.88					
MAX PIPE LENGTH/HEIGHT		m	20 / 8		30 / 15	20 / 8		25 / 15
OPERATING RANGE (°C) (OUTDOOR TEMPERATURE)	COOLING		21 to 43		0 to 43	0 to 43		
	HEATING		—	—	—	0 to 24		-5 to 24
REMOTE CONTROLLER TYPE			WIRELESS (HANDY)					

## 1.2 CEILING WALL (AW MODEL)

TYPE		COOLING			COOLING & HEATING				
MODEL	INDOOR	AW□18ABA-W	AW□24ABA-W	AW□30ABA-W	AW□14RBA-W	AW□18RBA-W	AW□24RBA-W	AW□30RBA-W	
	OUTDOOR	AO□18ANE	AO□24AME	AO□30AMAL	AO□14RGEC	AO□18RMEL	AO□24RMEL	AO□30RMAL	
POWER SOURCE		V/φ/Hz	220 - 240 / 1 / 50						
CAPACITY	COOLING	kW	5.30 - 5.40	6.80 - 6.90	8.05 - 8.20	4.20 - 4.30	5.30 - 5.40	6.80 - 6.90	7.80 - 8.00
		BTU/h	18,100 - 18,400	23,200 - 23,600	27,500 - 28,000	14,300 - 14,700	18,100 - 18,400	23,200 - 23,600	26,600 - 27,300
	HEATING	kW	—	—	—	4.80 - 4.90	5.50 - 5.60	7.70 - 7.80	8.55 - 8.80
		BTU/h	—	—	—	16,400 - 16,700	18,800 - 19,100	26,300 - 26,600	29,200 - 30,000
RUNNING CURRENT	COOLING	A	8.4 - 8.0	12.2 - 11.3	13.8 - 13.7	7.2 - 7.2	8.8 - 8.5	11.9 - 11.1	13.7 - 13.5
	HEATING		—	—	—	7.3 - 7.3	7.8 - 7.7	12.1 - 11.4	14.5 - 14.4
POWER CONSUMPTION	COOLING	kW	1.84 - 1.89	2.61 - 2.65	2.96 - 3.08	1.54 - 1.63	1.89 - 1.98	2.60 - 2.65	2.93 - 3.05
	HEATING		—	—	—	1.51 - 1.63	1.70 - 1.80	2.64 - 2.72	3.13 - 3.25
STARTING CURRENT		A	43	56	90	41	52	56	90
MOISTURE REMOVAL		ℓ/h (pints/h)	2.0 (4.3)	2.5 (5.3)	3.0 (6.4)	1.6 (3.4)	2.0 (4.3)	2.5 (5.3)	3.0 (6.4)
E.E.R.	COOLING	kW/kW	2.88 - 2.86	2.61 - 2.60	2.72 - 2.66	2.73 - 2.64	2.80 - 2.73	2.62 - 2.60	2.66 - 2.62
	HEATING		—	—	—	3.18 - 3.01	3.24 - 3.11	2.92 - 2.87	2.73 - 2.71
FAN SPEED (r.p.m.)	INDOOR	HIGH	1,160	1,300	1,380	1,050	1,160	1,300	1,380
		MED	1,020	1,180	1,250	900	1,020	1,180	1,250
		LOW	880	1,060	1,120	770	880	1,060	1,120
	OUTDOOR		735	720	730	750	720	720	730
AIR FLOW	INDOOR	m <sup>3</sup> /h (C.F.M.)	850 (500)	1,000 (590)	1,050 (620)	700 (410)	850 (500)	1,000 (590)	1,050 (620)
	OUTDOOR		2,590 (1,520)		3,320 (1,950)	1,600 (940)	2,590 (1,520)		3,320 (1,950)
SOUND PRESSURE LEVEL (dB)	INDOOR	HIGH	39	43	46	34	39	43	46
		MED	36	40	44	32	36	40	44
		LOW	33	36	41	30	33	36	41
	OUTDOOR		55			51	55		56
DIMENSIONS H x W x D (mm)	NET	INDOOR	270 x 1,150 x 285						
		OUTDOOR	643 x 840 x 336		900 x 900 x 350	530 x 750 x 250	643 x 840 x 336		900 x 900 x 350
	GROSS	INDOOR	400 x 1,260 x 380						
		OUTDOOR	750 x 959 x 429		1,045 x 1,025 x 445	609 x 882 x 339	750 x 959 x 429		1,045 x 1,025 x 445
WEIGHT [NET/GROSS]	INDOOR	kg (lbs)	16 (35) / 20 (44)						
	OUTDOOR		59(130) / 67(148)	65(143) / 73(161)	79(174) / 91(200)	37(82) / 39(86)	68(150) / 76(168)	69(152) / 77(169)	80(176) / 92(202)
CONNECTION PIPE SIZE (mm)		SMALL/LARGE	φ 9.52 / φ 15.88			φ 6.35 / φ 12.7		φ 9.52 / φ 15.88	
MAX PIPE LENGTH/HEIGHT		m	20 / 8		30 / 15	15 / 5	20 / 8		25 / 15
OPERATING RANGE (°C) (OUTDOOR TEMPERATURE)	COOLING		21 to 43		0 to 43	21 to 43	0 to 43		
	HEATING		—	—	—	0 to 24			-5 to 24
REMOTE CONTROLLER TYPE			WIRELESS (HANDY)						

Note : In the above square, put the Y, G, or F by a destination.

# 2. DIMENSIONAL OUTLINE DRAWING

## 2.1 INDOOR UNIT

MODELS : AS □ 18A, 18R, 24A, 24R, 30A, 30R

Unit : mm (inch)

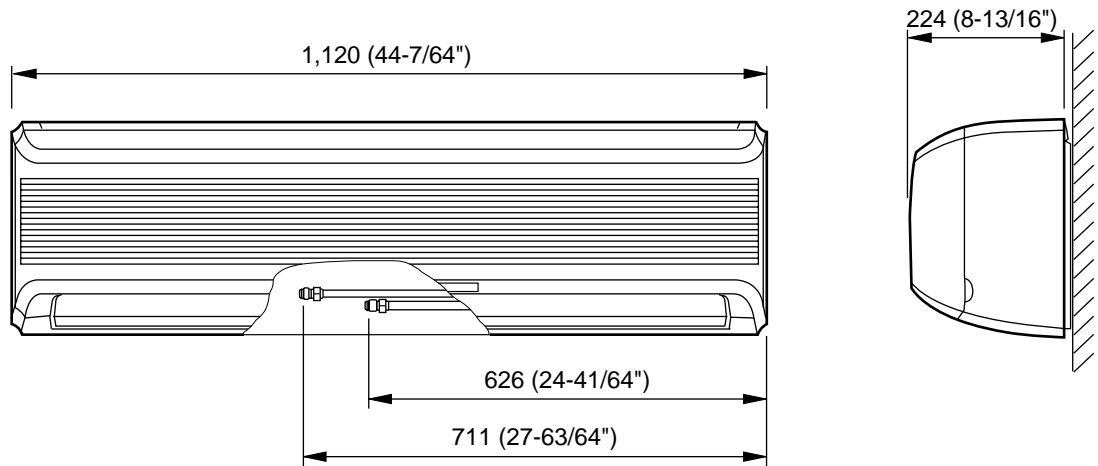

Connecting pipe  
 Gas :  $\varnothing 15.88$  (5/8")  
 Liquid :  $\varnothing 9.52$  (3/8")

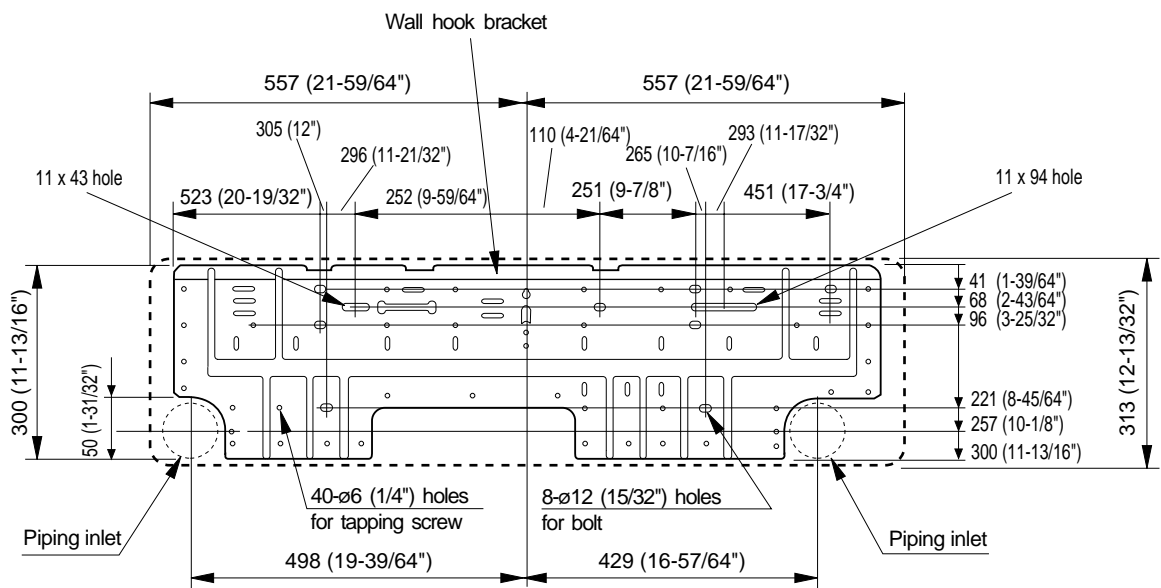
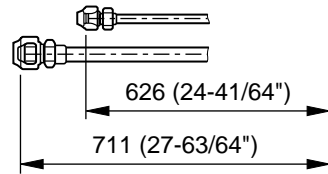

**MODELS : AW □ 14, 18, 24, 30**

Unit : mm (inch)

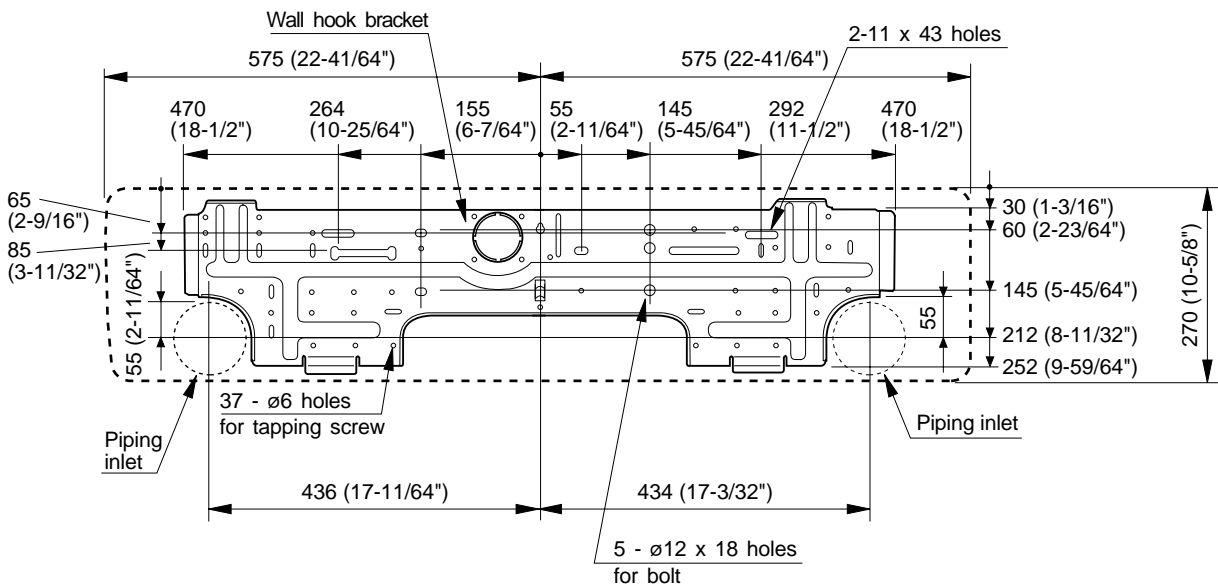
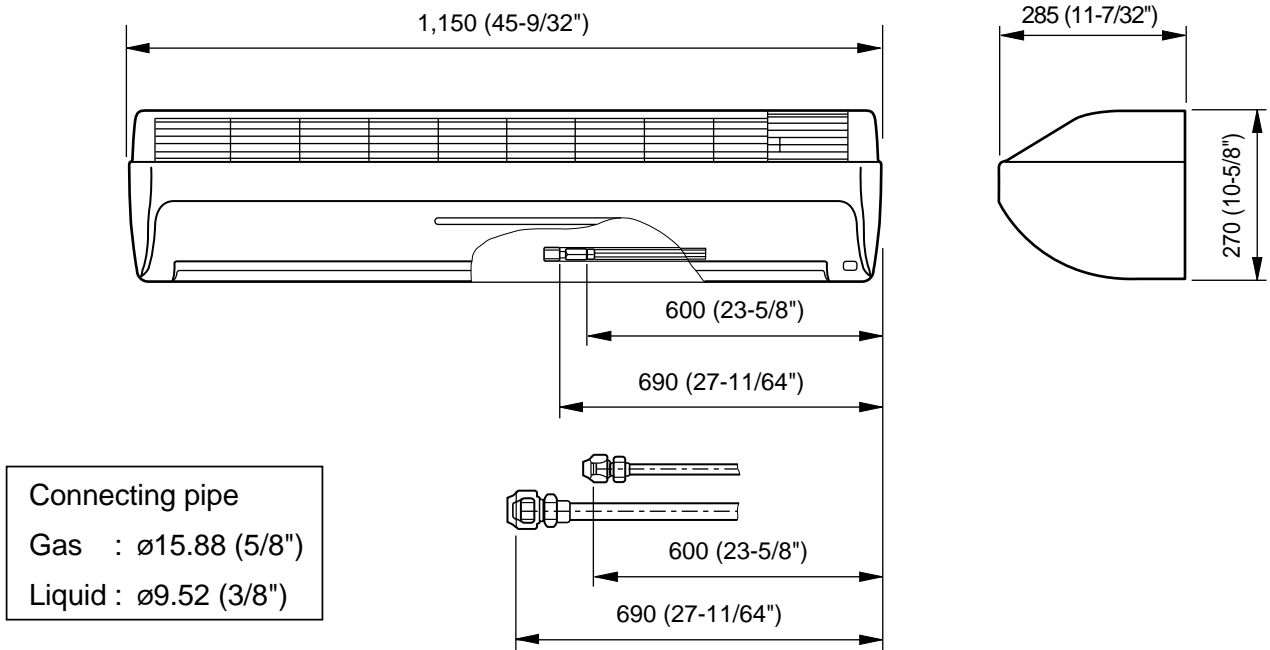

## 2.2 OUTDOOR UNIT

APPLICATION MODEL : AO □ 14R

Unit : mm (inch)

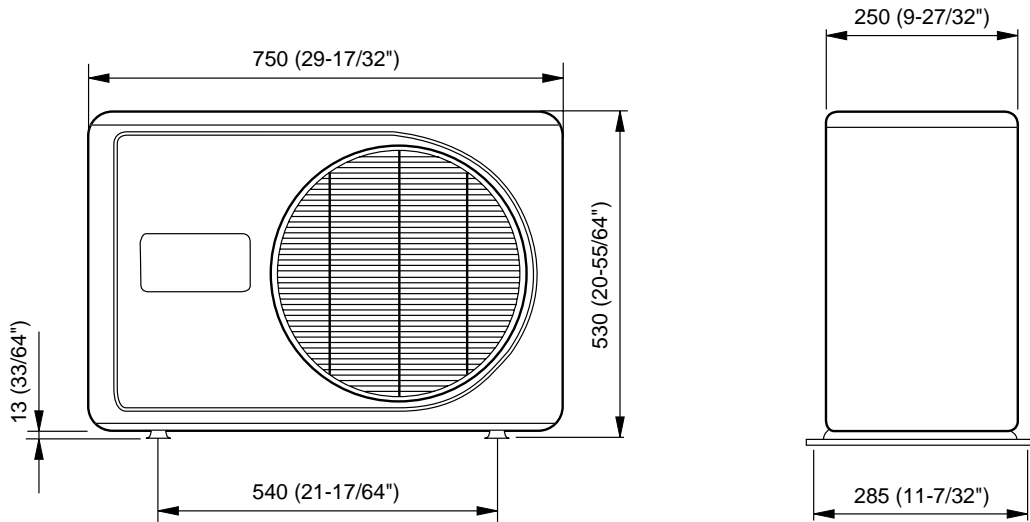

MODELS : AO □ 18 / 24R,  
AO □ 18 / 24A

MODELS : AO □ 30R,  
AO □ 30A

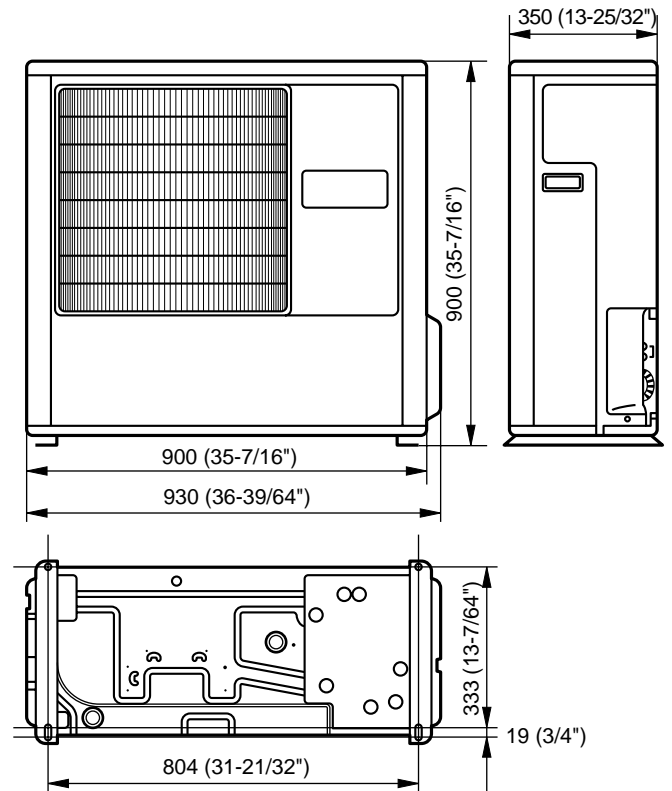
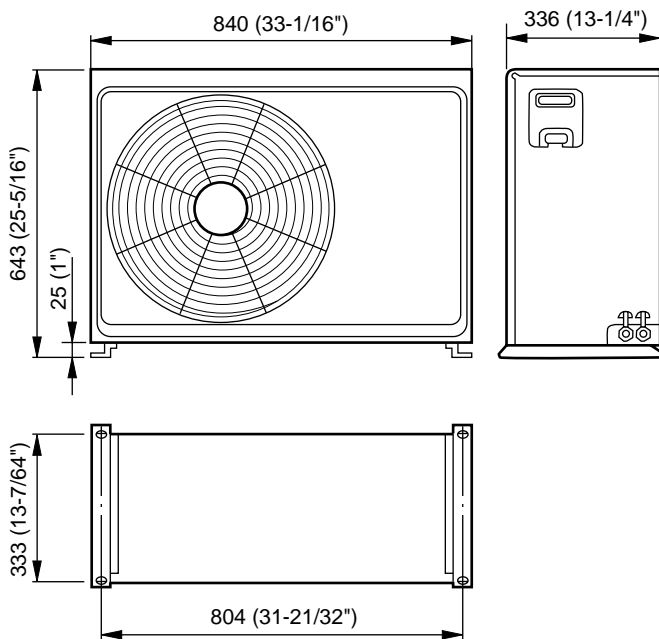



# 3.3 AS □ 30A

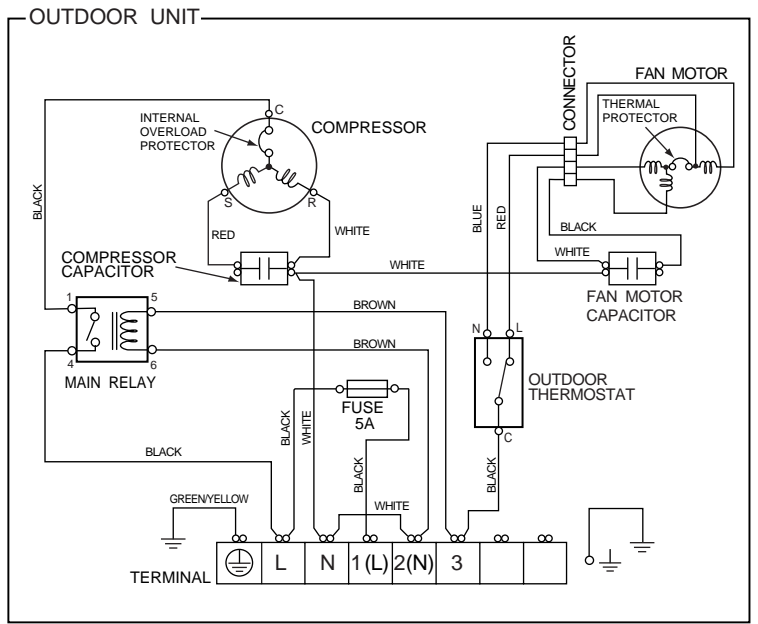
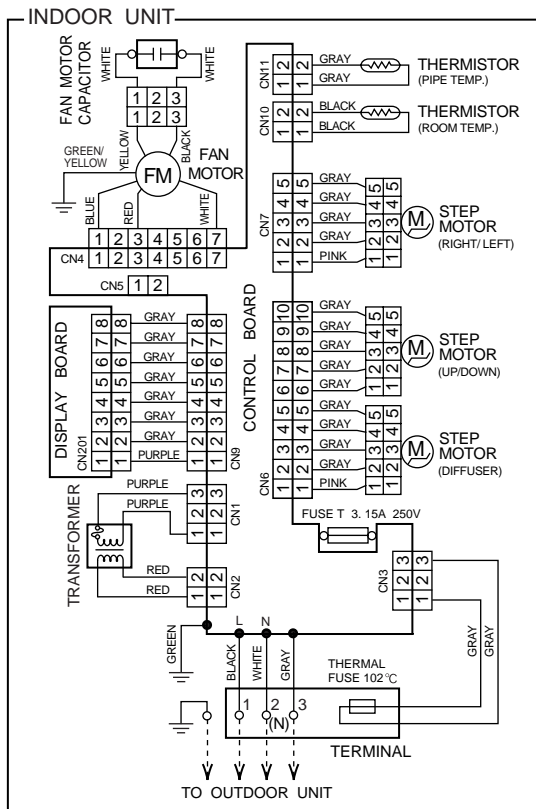

# 3.4 AS □ 30R

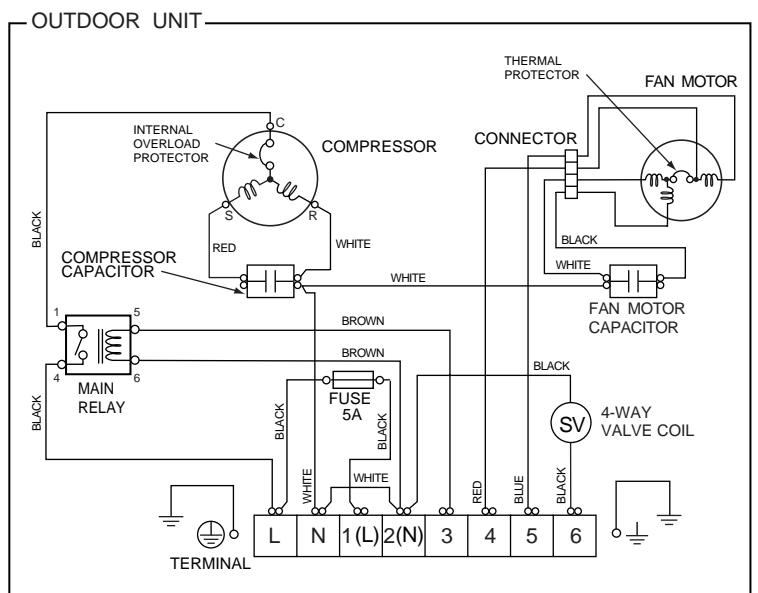
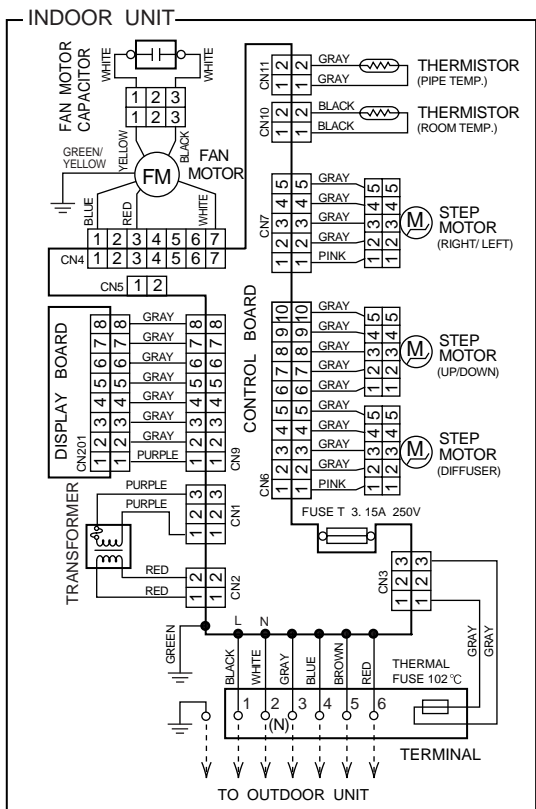



# 3.5 AW □ 14R

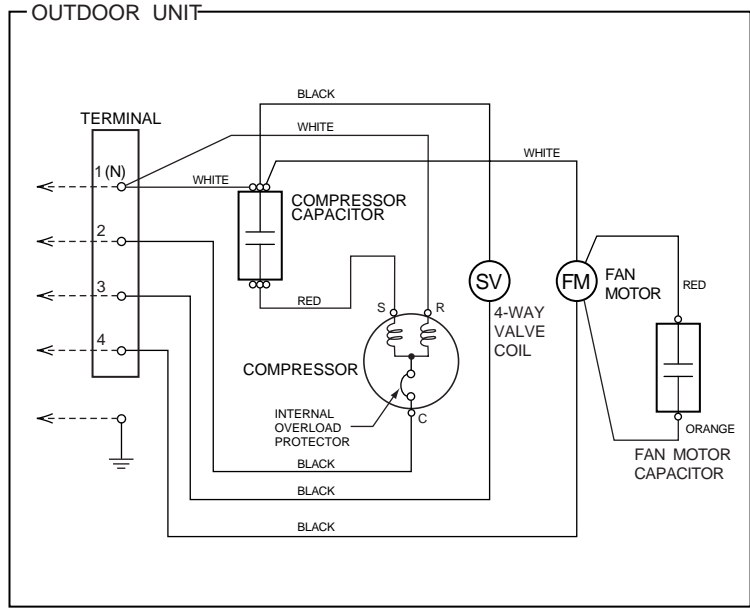
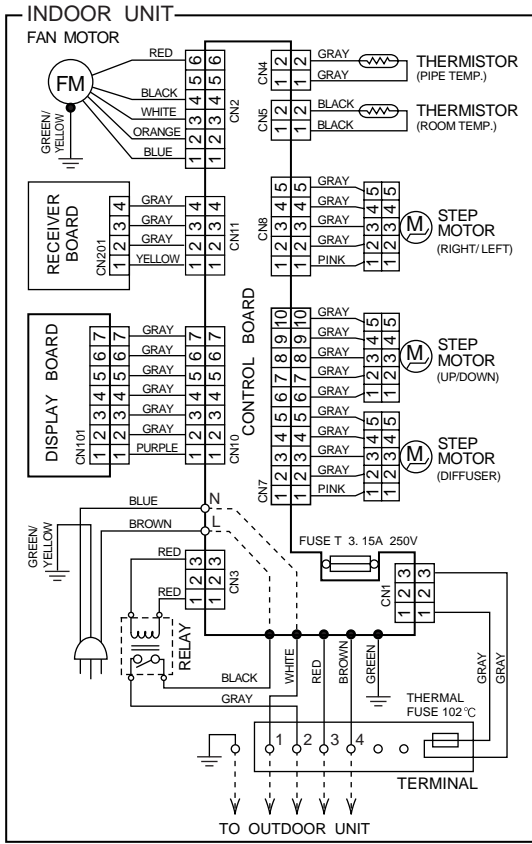

# 3.6 AW □ 18 / 24A

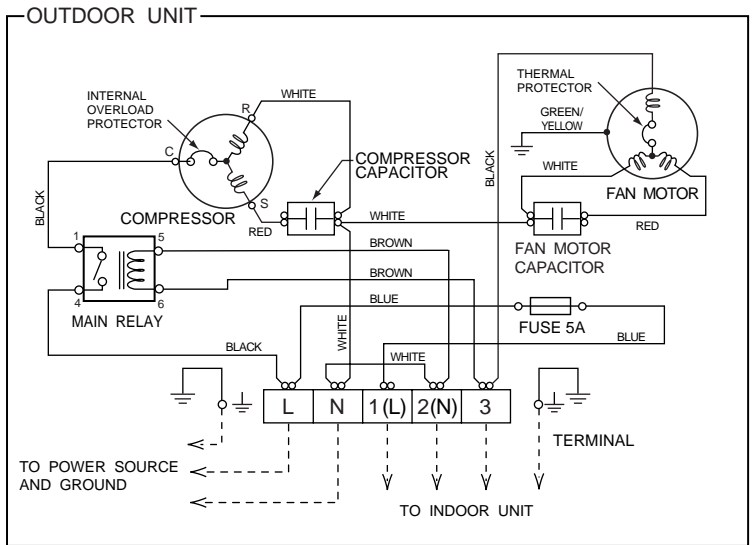
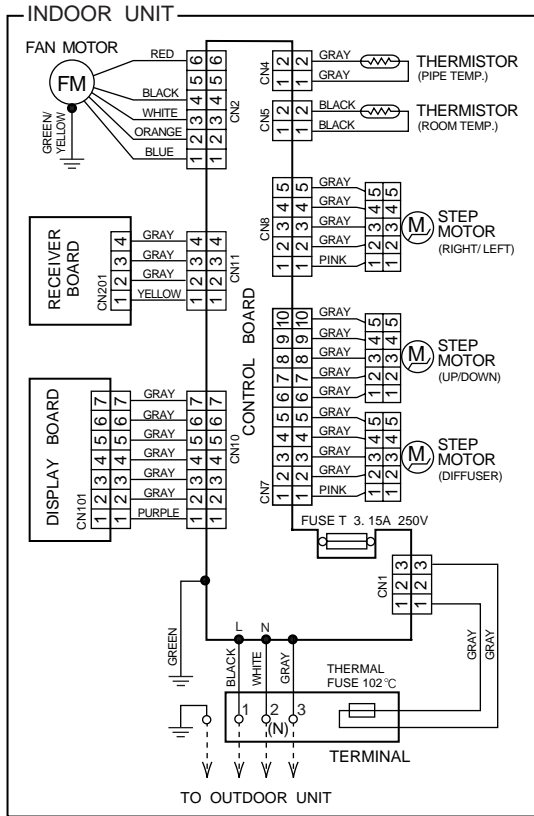

# 3.7 AW □ 18 / 24R

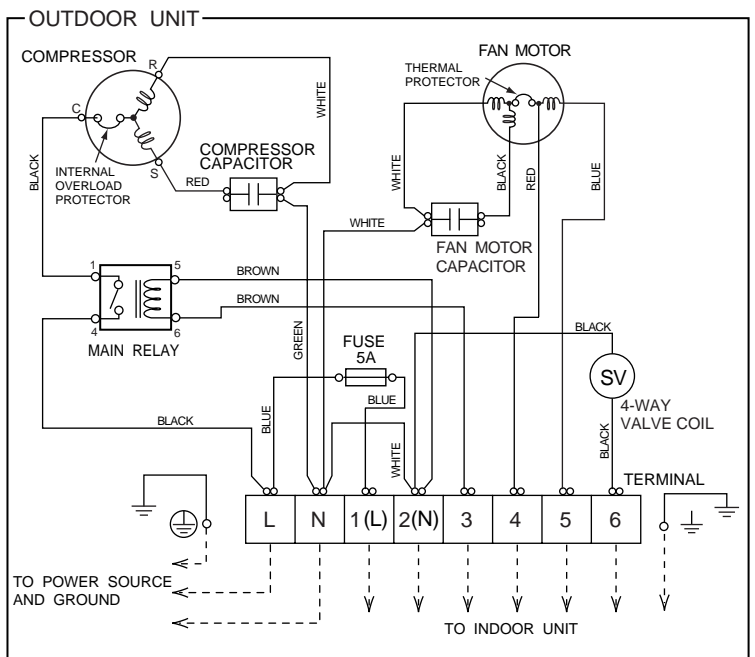
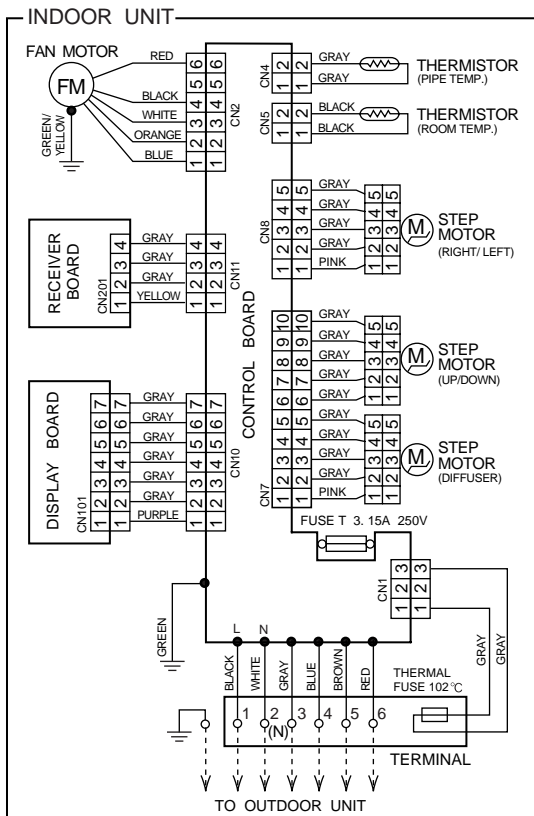

# 3.8 AW □ 30A

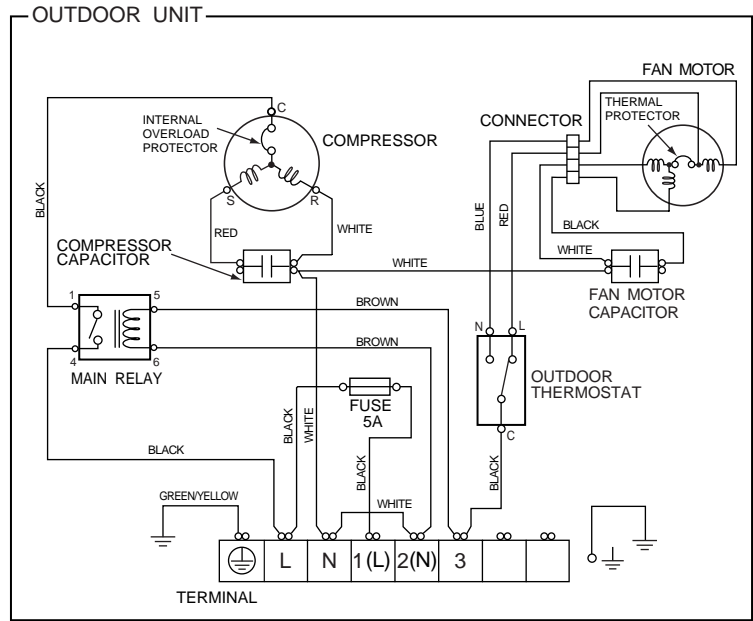
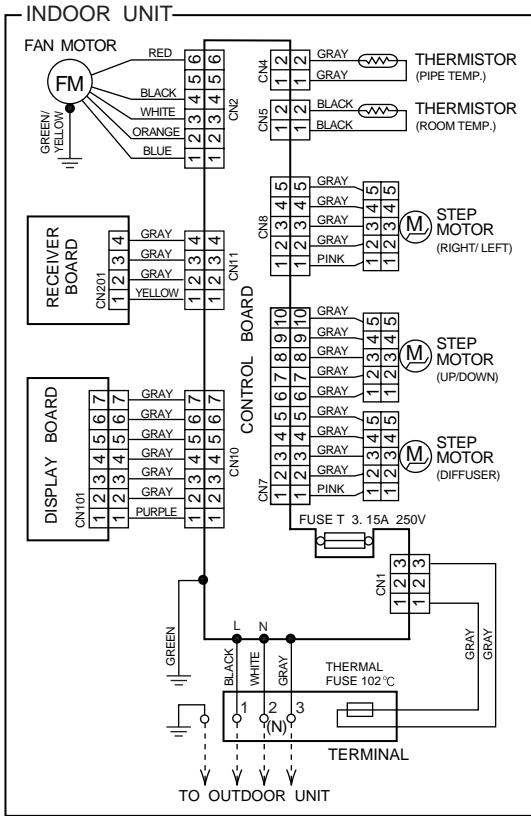

# 3.9 AW □ 30R

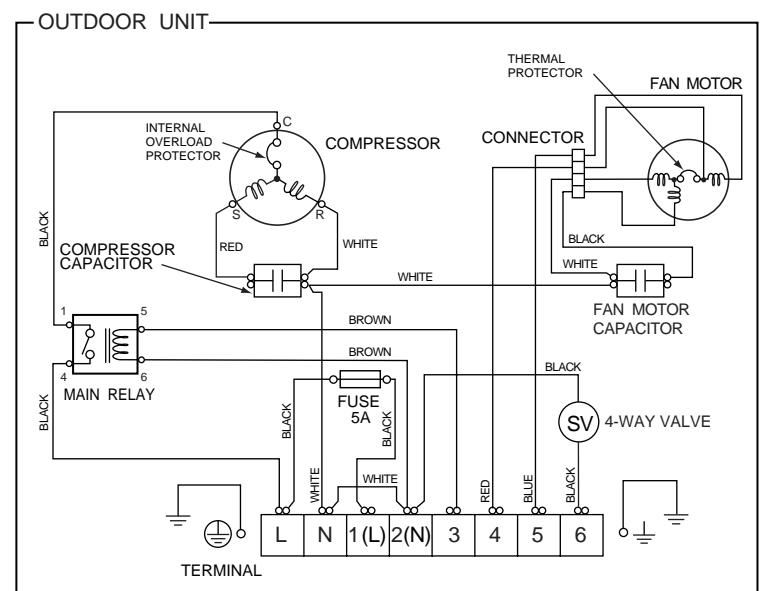
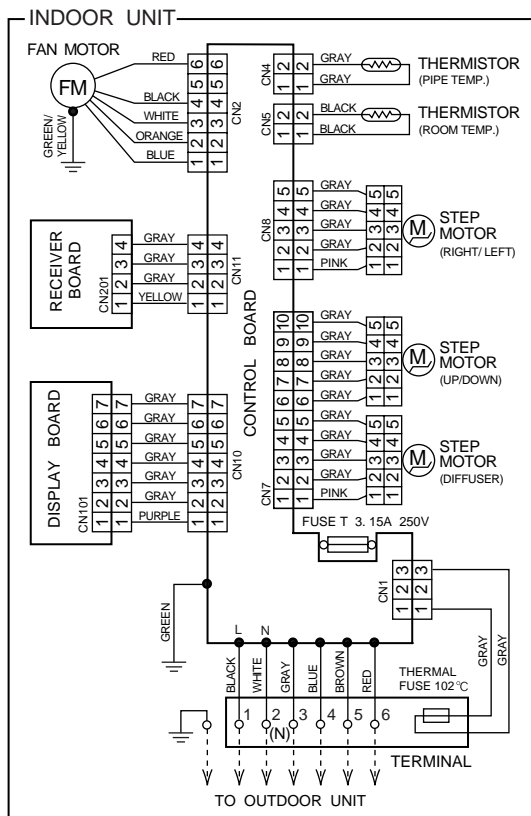

# 4. REMOTE CONTROL UNIT

Used common to AS and AW models.

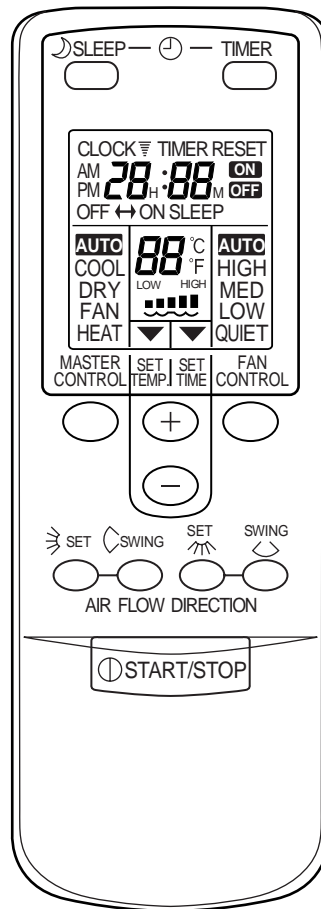

# 5. REFRIGERANT CYCLE

## 5.1 AW □ 14R

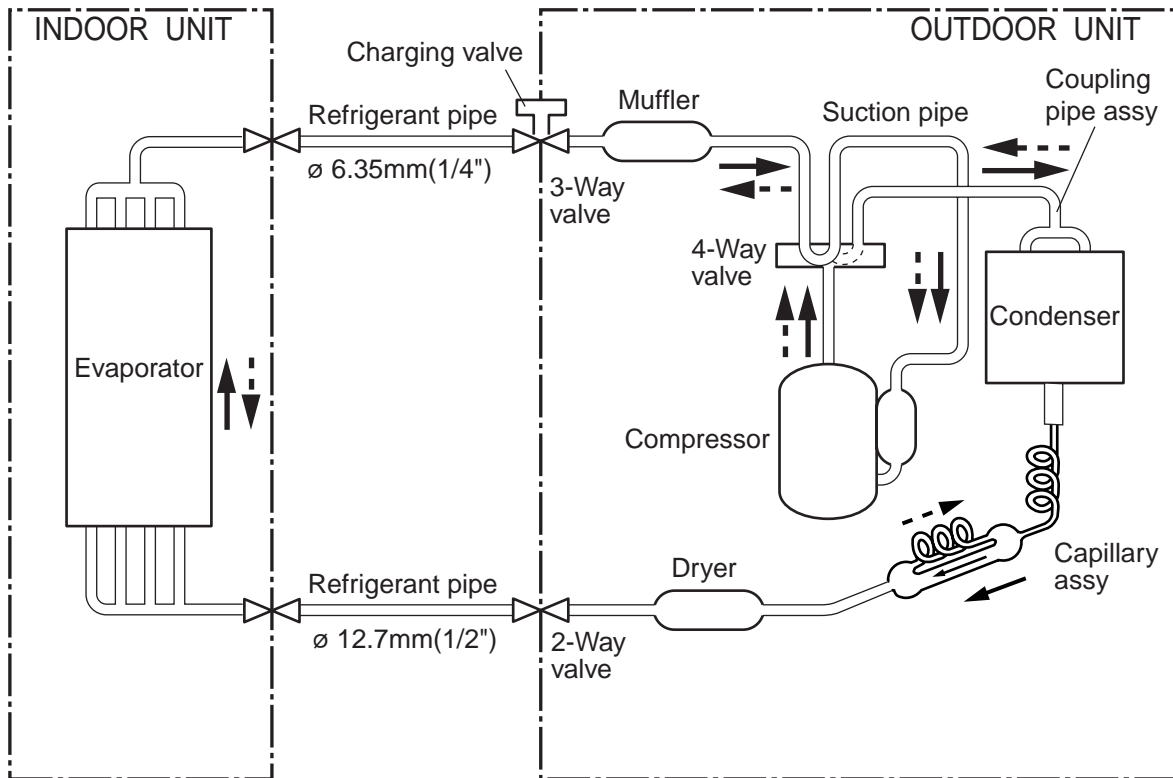

## 5.2 AS □ 18A, AW □ 18A

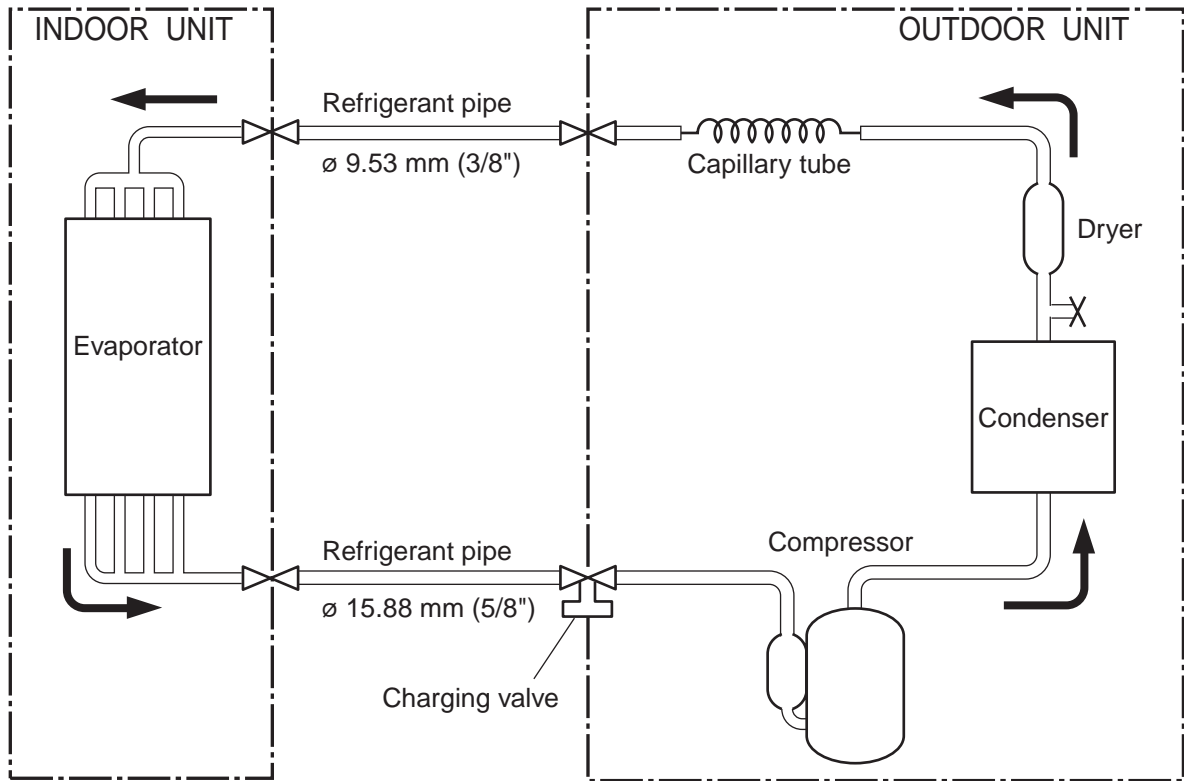

## 5.3 AS □ 18R, AW □ 18R

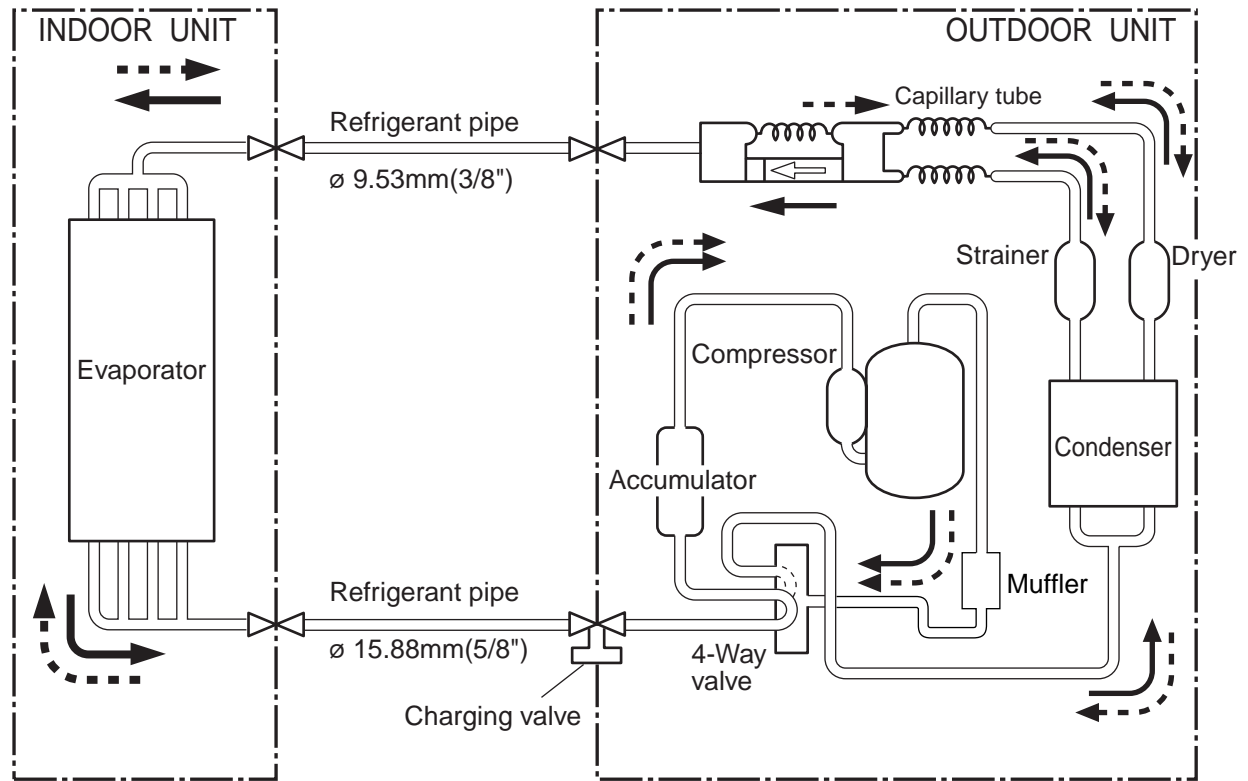

- Cooling
- Heating
- : Flare coupling

**5.4 AS □ 24A, AW □ 24A**

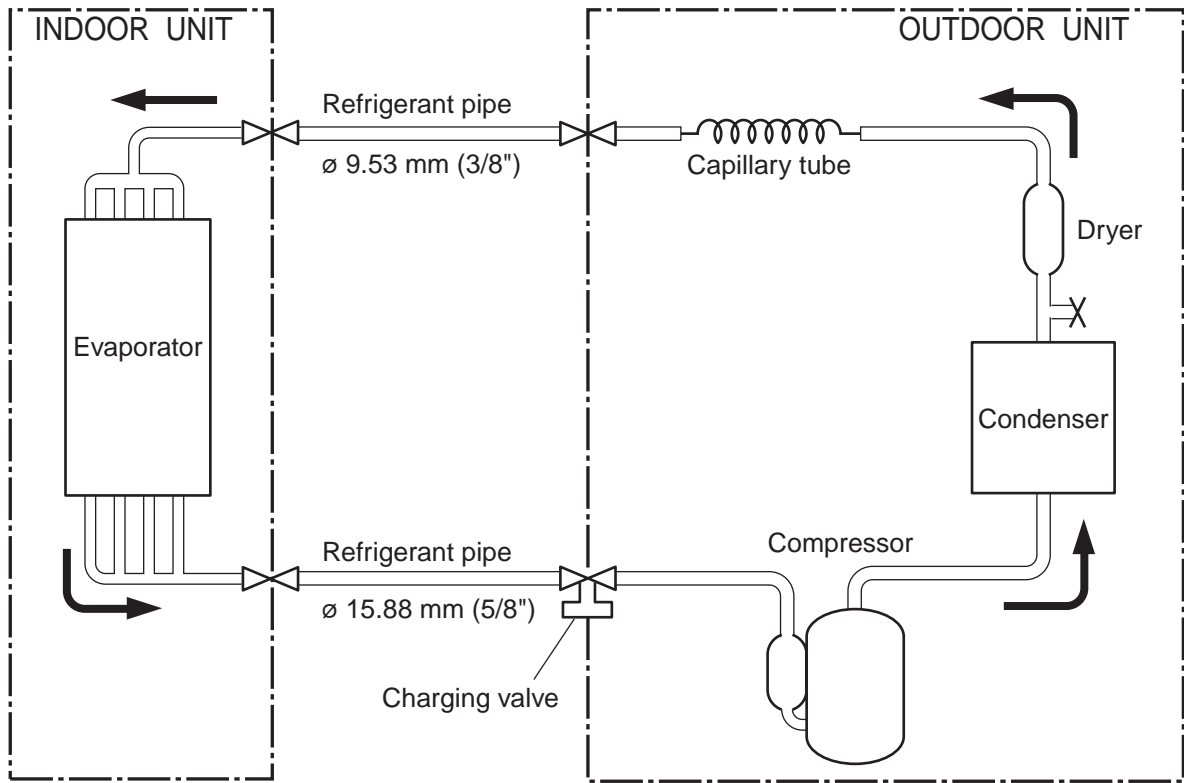

**5.5 AS □ 24R, AW □ 24R**

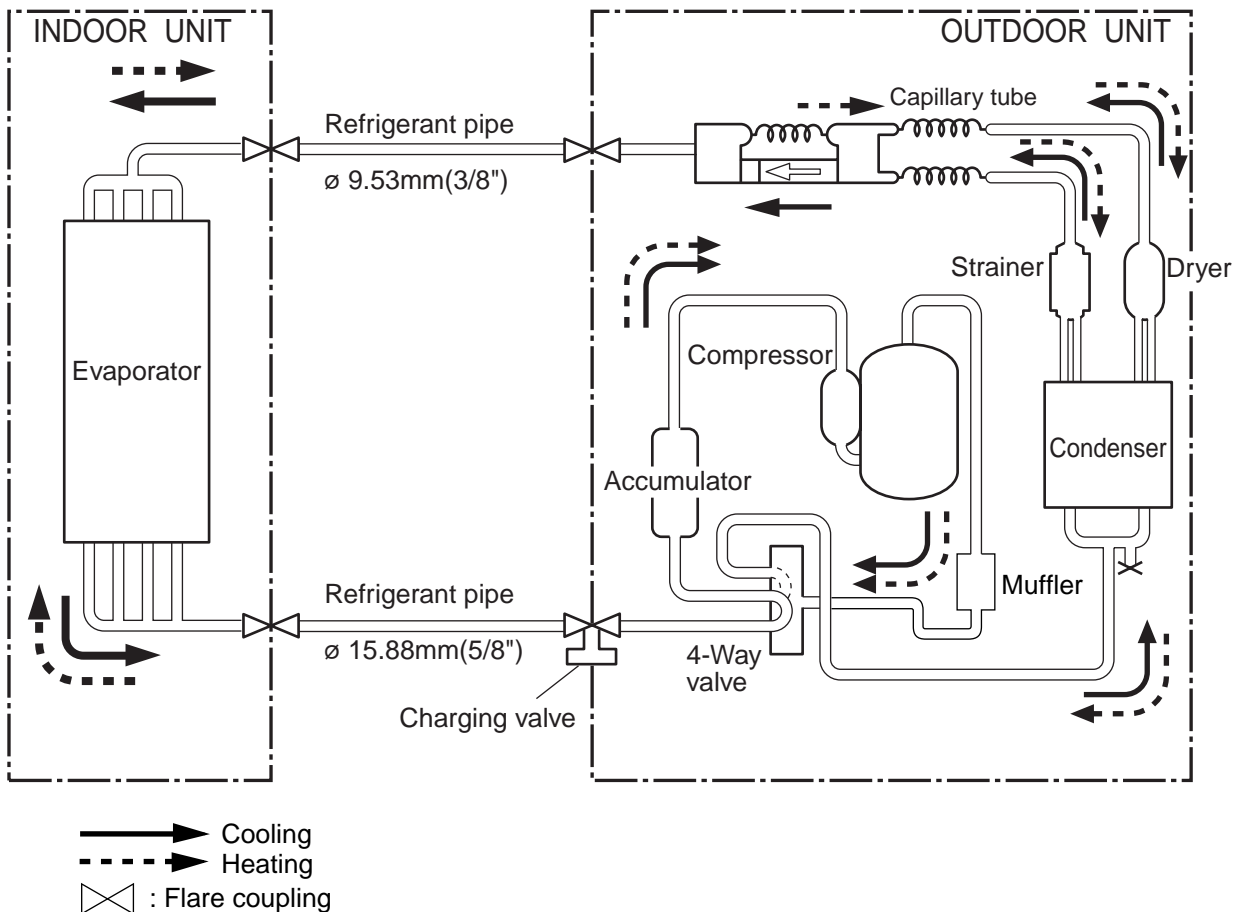

## 5.6 AW □ 30A, AW □ 30A

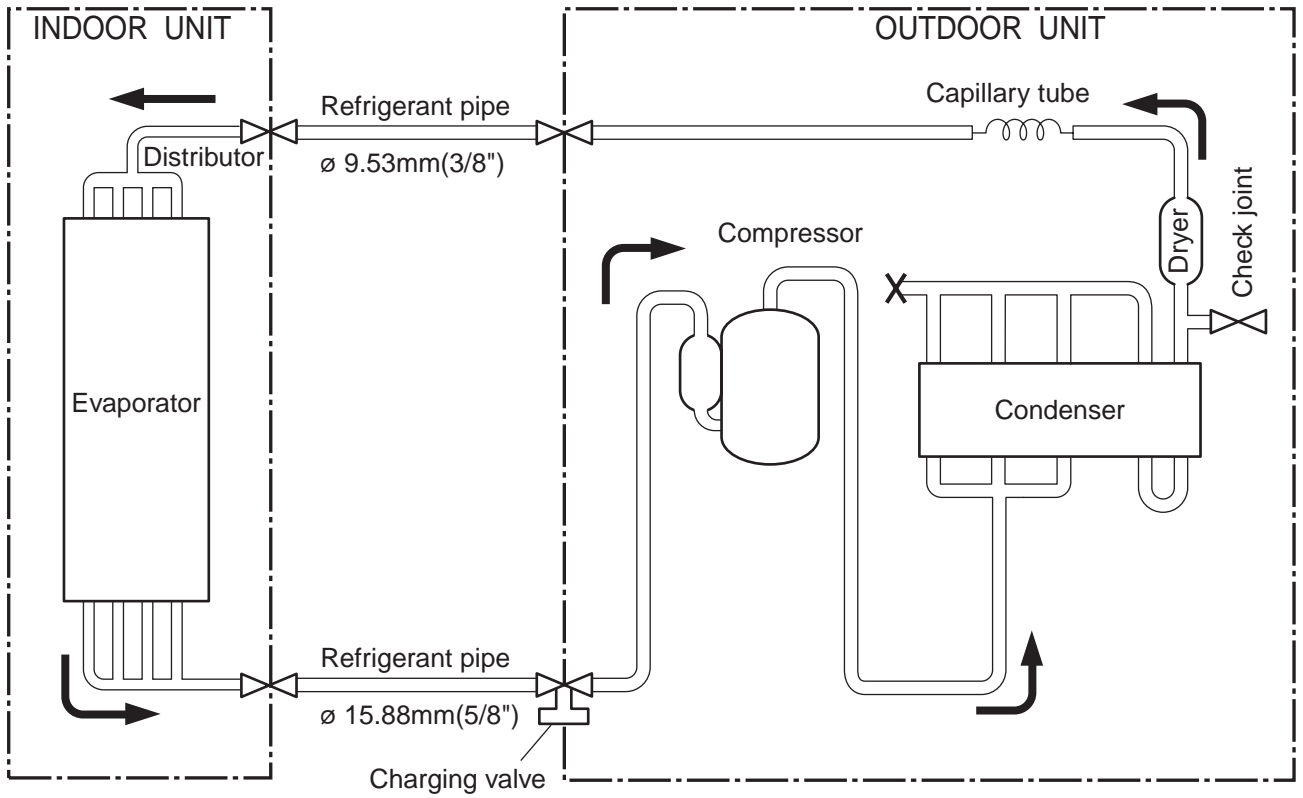

## 5.7 AS □ 30R, AW □ 30R

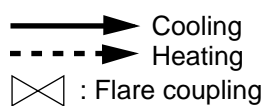
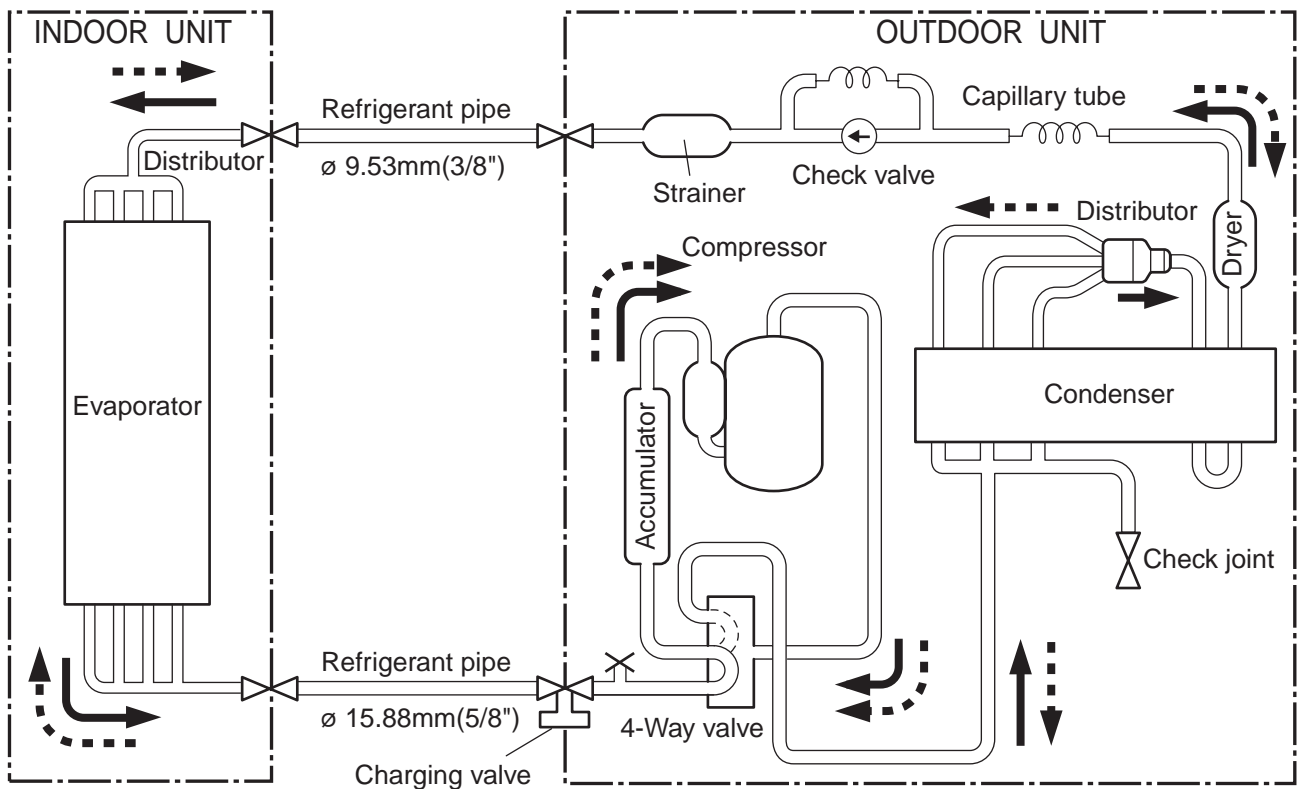



# 6. REFRIGERANT CHARGING

## 6.1 AS, AW MODEL

MODELS		PIPE LENGTH							Additional refrigerant g/m(oz/ft)
		5m (17ft)	7.5m (25ft)	10m (33ft)	15m (49ft)	20m (66ft)	25m (82ft)	30m (98ft)	
FULL CHARGE AMOUNT	AW□14R/ AO□14R	1,300g (45.9oz)	1,350g (47.6oz)	1,400g (49.4oz)	1,500g (52.9oz)	—	—	—	20g (0.22oz)
	AS□18A/ AW□18A/ AO□18A	—	1,400g (49.4oz)	1,450g (51.2oz)	1,550g (54.7oz)	1,650g (58.2oz)	—	—	20g (0.22oz)
	AS□18R/ AW□18R/ AO□18R	—	1,900g (67.0oz)	2,000g (70.6oz)	2,200g (77.6oz)	2,400g (84.7oz)	—	—	40g (0.43oz)
	AS□24A/ AW□24A/ AO□24A	—	1,850g (65.2oz)	1,900g (67.0oz)	2,000g (70.6oz)	2,100g (74.1oz)	—	—	20g (0.22oz)
	AS□24R/ AW□24R/ AO□24R	—	2,200g (77.6oz)	2,300g (81.1oz)	2,500g (88.2oz)	2,700g (95.2oz)	—	—	40g (0.43oz)
	AS□30A/ AW□30A/ AO□30A	—	2,300g (81.1oz)	2,350g (82.9oz)	2,450g (86.4oz)	2,550g (90.0oz)	2,650g (93.5oz)	2,750g (97.0oz)	20g (0.22oz)
	AS□30R/ AW□30R/ AO□30R	—	2,450g (86.4oz)	2,550g (90.0oz)	2,750g (97.0oz)	2,950g (104oz)	3,150g (111oz)	—	40g (0.43oz)

# 7. TEMPERATURE RANGE

## 7.1 AS MODEL

MODELS		TEMPERATURE RANGE	
		INDOOR UNIT	OUTDOOR UNIT
AS □ 18A AS □ 24A	COOL	About 18 to 32°C	About 21 to 43°C
	DRY		
AS □ 18R AS □ 24R	COOL	About 18 to 32°C	About 0 to 43°C
	DRY		
	HEAT	About 30°C or less	About 0 to 24°C
AS □ 30A	COOL	About 18 to 32°C	About 0 to 43°C
	DRY		
AS □ 30R	COOL	About 18 to 32°C	About 0 to 43°C
	DRY		
	HEAT	About 30°C or less	About -5 to 24°C

## 7.2 AW MODEL

MODELS		TEMPERATURE RANGE	
		INDOOR UNIT	OUTDOOR UNIT
AW □ 14R	COOL	About 18 to 32°C	About 21 to 43°C
	HEAT		
AW □ 18A AW □ 24A	COOL	About 18 to 32°C	About 21 to 43°C
	DRY		
AW □ 18R AW □ 24R	COOL	About 18 to 32°C	About 0 to 43°C
	HEAT		
AW □ 30A	COOL	About 18 to 32°C	About 0 to 43°C
	DRY		
AW □ 30R	COOL	About 18 to 32°C	About 0 to 43°C
	HEAT		

# 8. AIR VELOCITY DISTRIBUTION

## 8.1 AS MODEL

Condition  
 Fan speed : High  
 Operation mode : Fan  
 Type : AS□24  
 Voltage : 240V (50Hz)

Fig. 8.1-1  
 TOP VIEW  
 FLOW CONTROL PANEL : Horiz.  
 LOUVER : Center

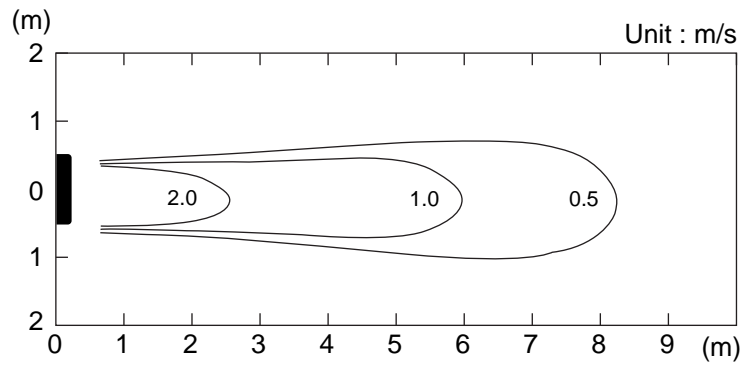

Fig. 8.1-2  
 TOP VIEW  
 FLOW CONTROL PANEL : Horiz.  
 LOUVER : Right & Left

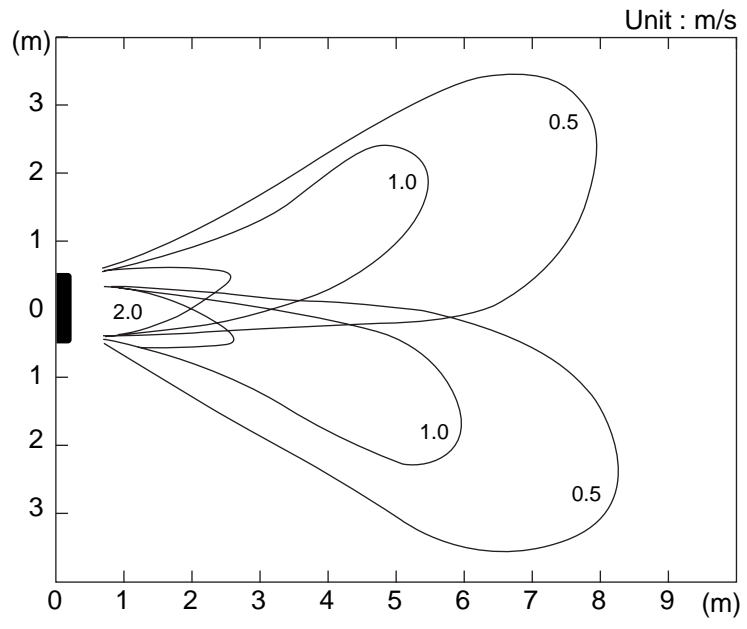

Fig. 8.1-3  
 SIDE VIEW  
 FLOW CONTROL PANEL : Horiz.  
 LOUVER : Center

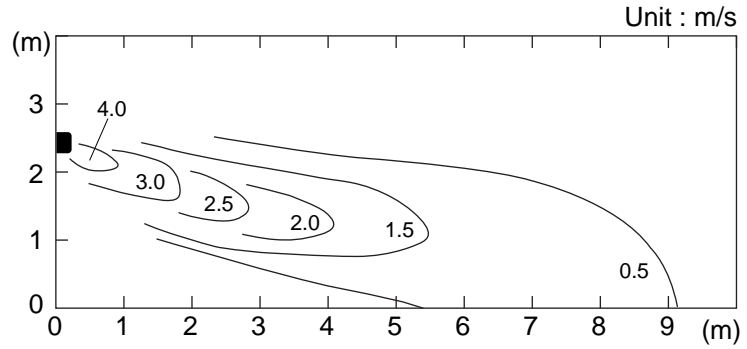
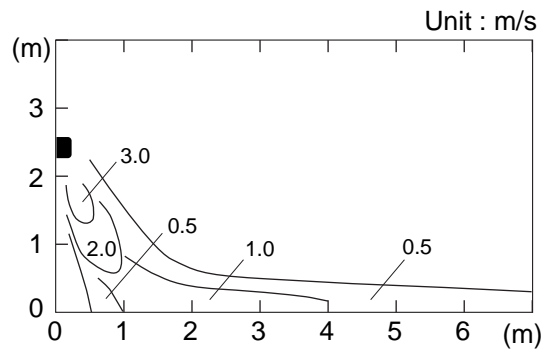

Fig. 8.1-4  
 SIDE VIEW  
 FLOW CONTROL PANEL : Vert.  
 LOUVER : Center



# 8.2 AW MODEL

Condition  
 Fan speed : High  
 Operation mode : Fan  
 Type : AW□24  
 Voltage : 240V

Fig. 8.2-1  
 TOP VIEW  
 FLOW CONTROL PANEL : Horiz.  
 LOUVER : Center

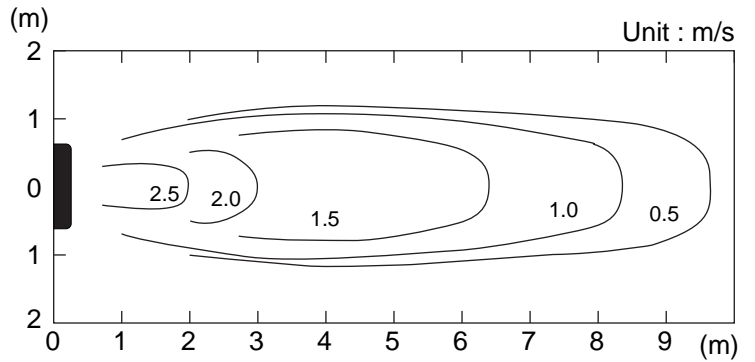

Fig. 8.2-2  
 TOP VIEW  
 FLOW CONTROL PANEL : Horiz.  
 LOUVER : Right & Left

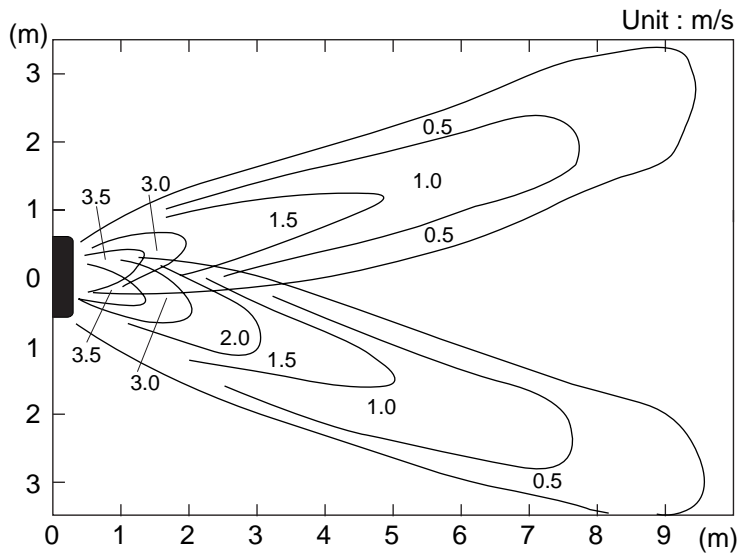

Fig. 8.2-3  
 SIDE VIEW  
 FLOW CONTROL PANEL : Horiz.  
 LOUVER : Center

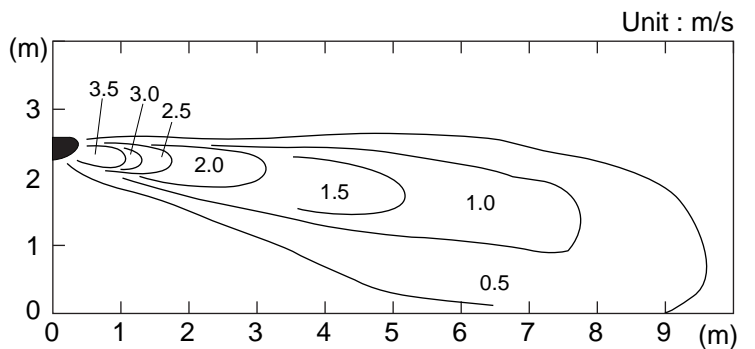
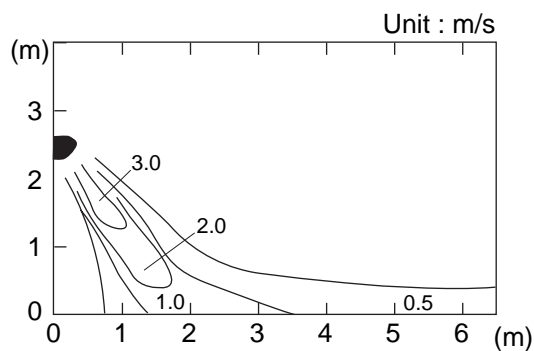
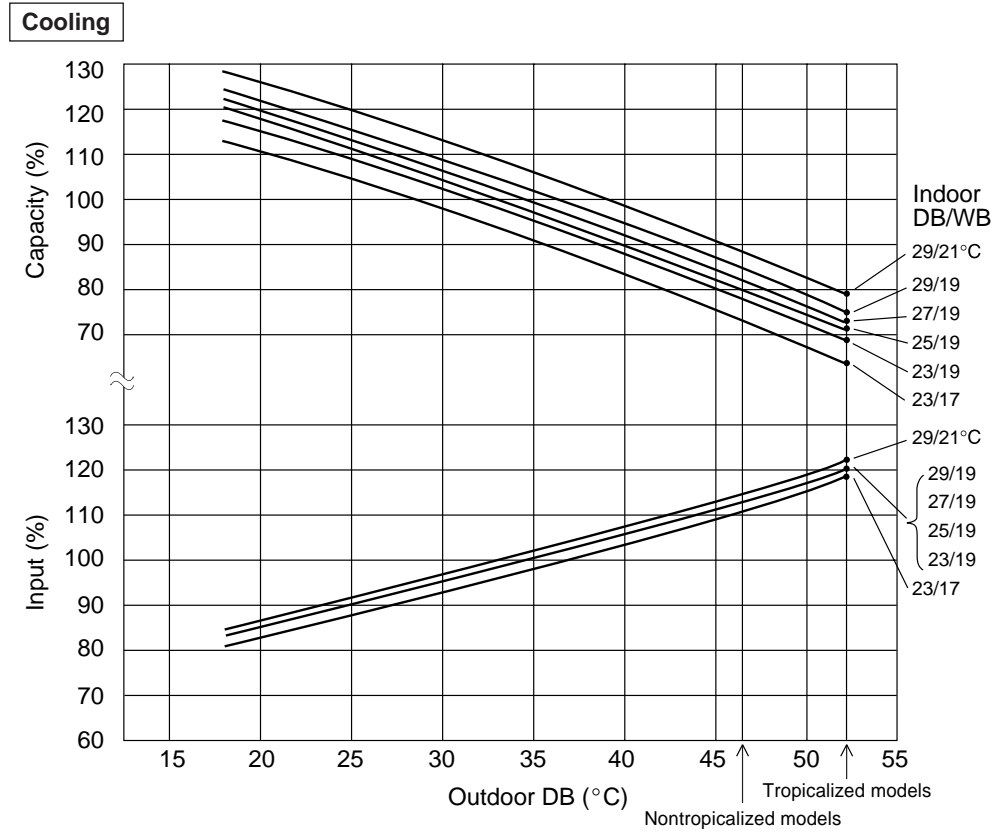

Fig. 8.2-4  
 SIDE VIEW  
 FLOW CONTROL PANEL : Vert.  
 LOUVER : Center



# 9. PERFORMANCE CURVE

**MODELS : AS □ 18A, 24A, AW □ 18A, 24A**



**MODELS : AS □ 30A, AW □ 30A**

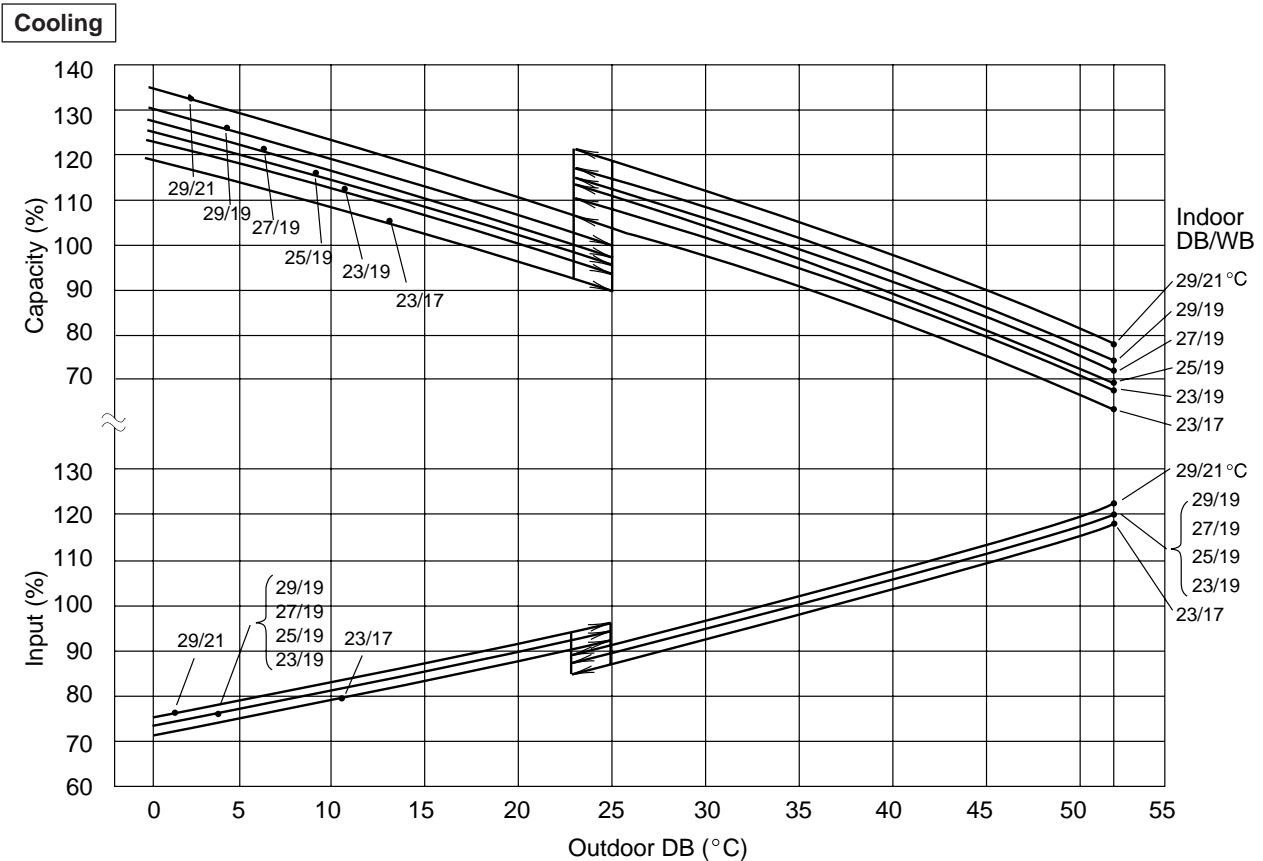

**MODELS : AS □ 14R, AW □ 14R**

**Cooling**

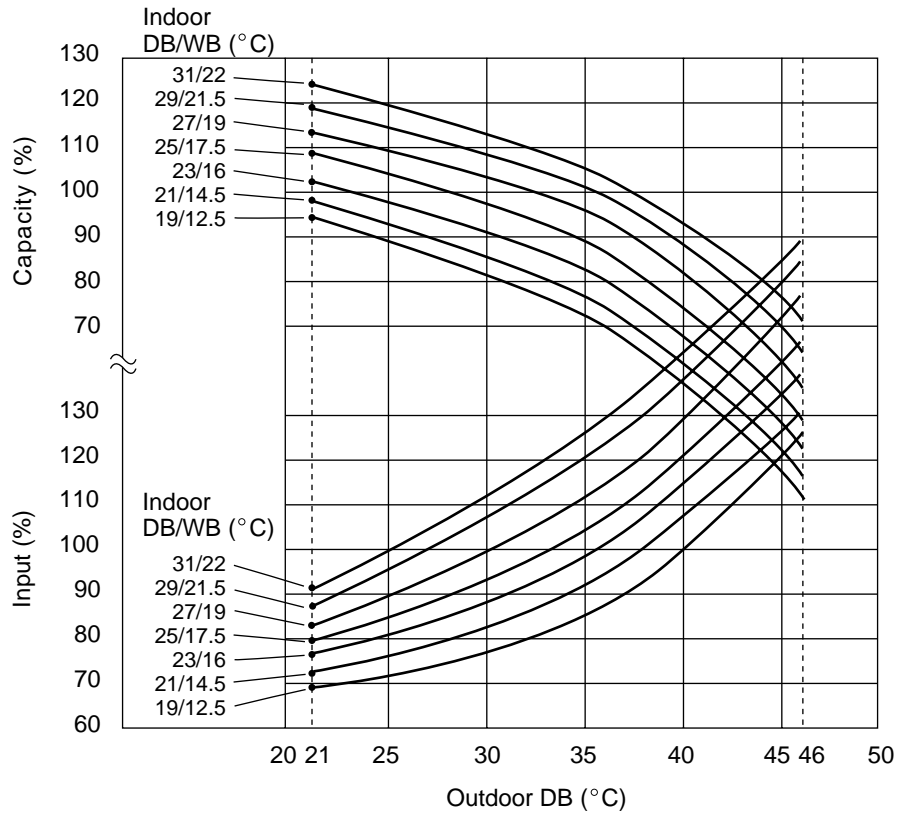

**Heating**

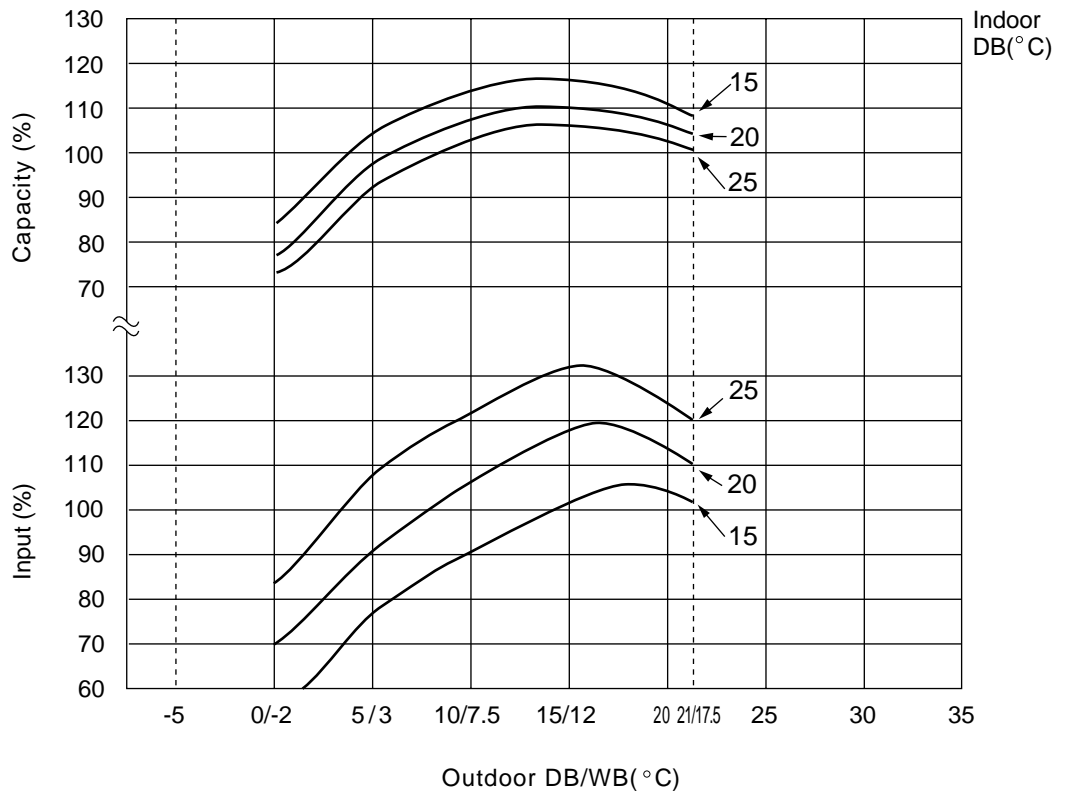

**MODELS : AS □ 18R, 24R, 30R**  
**AW □ 18R, 24R, 30R**

**Cooling**

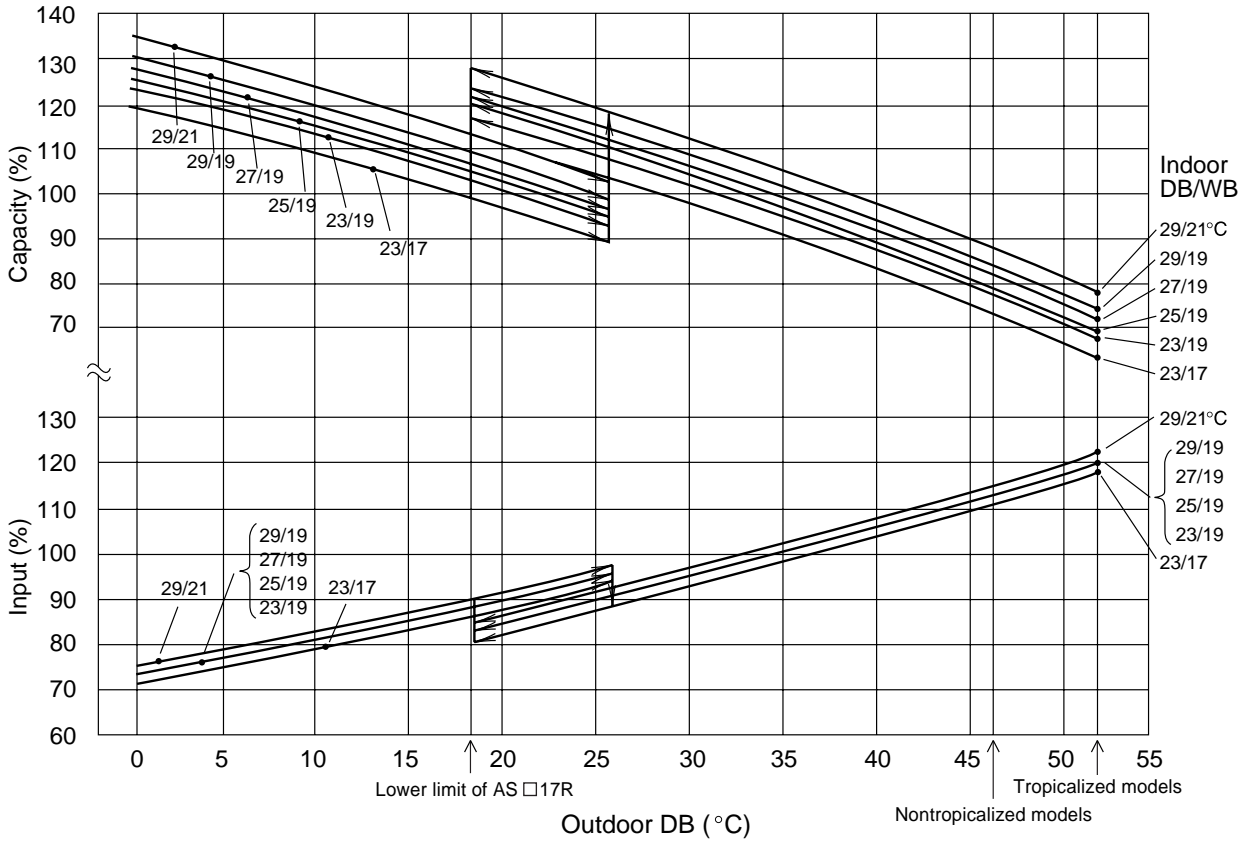

**Heating**

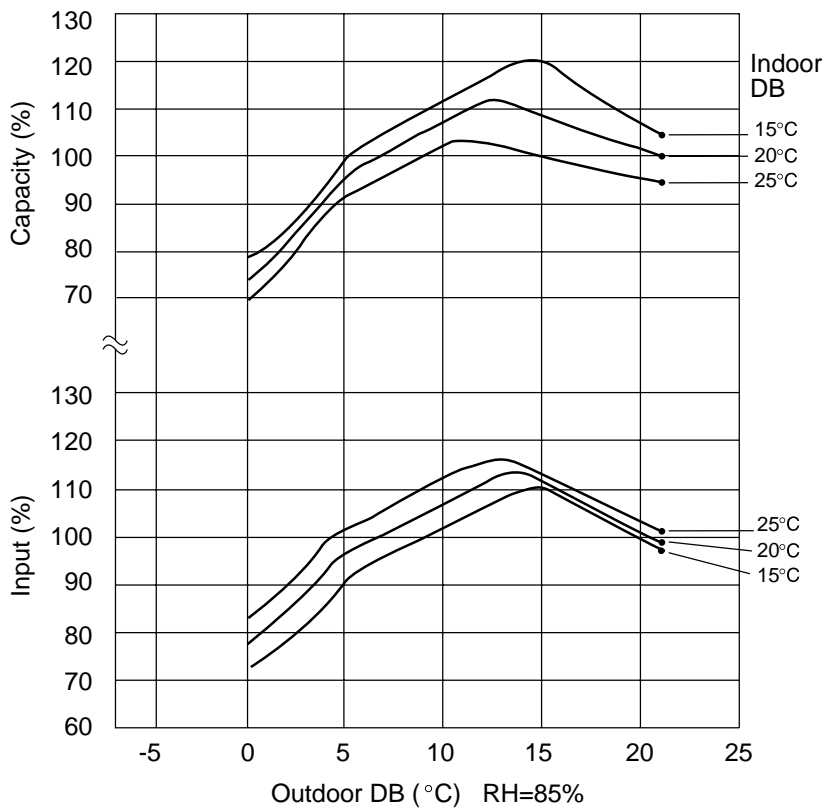

# 10. NOISE LEVEL MEASUREMENT

## 10.1 INDOOR UNIT

**AS□18ABA-W**  
(COOL)

240V COOL

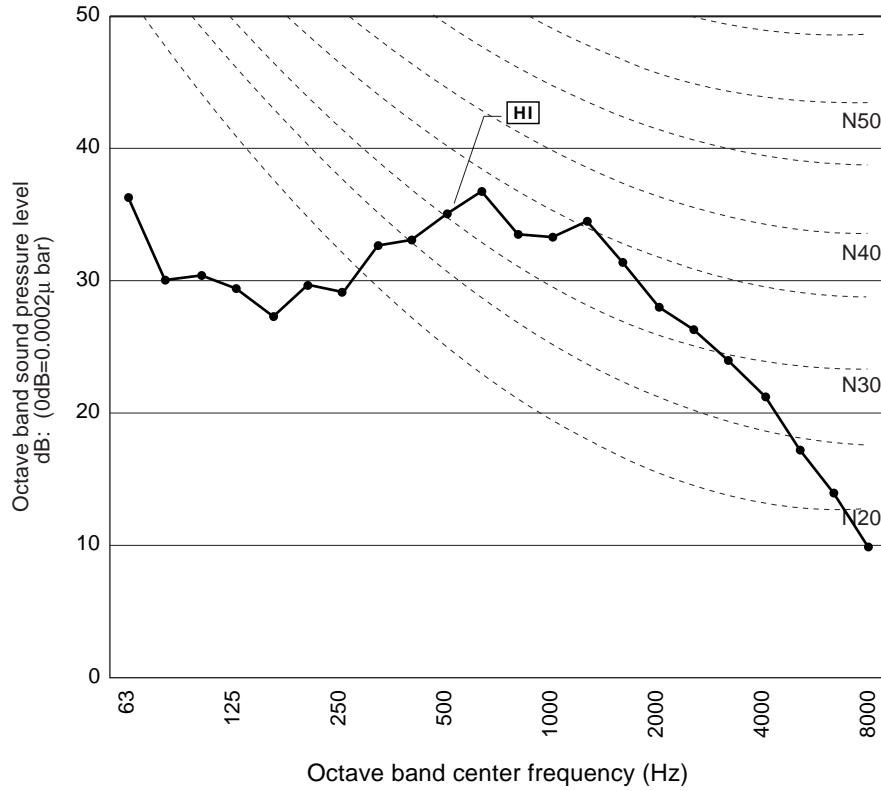

**AS□24ABA-W**  
(COOL)

240V COOL

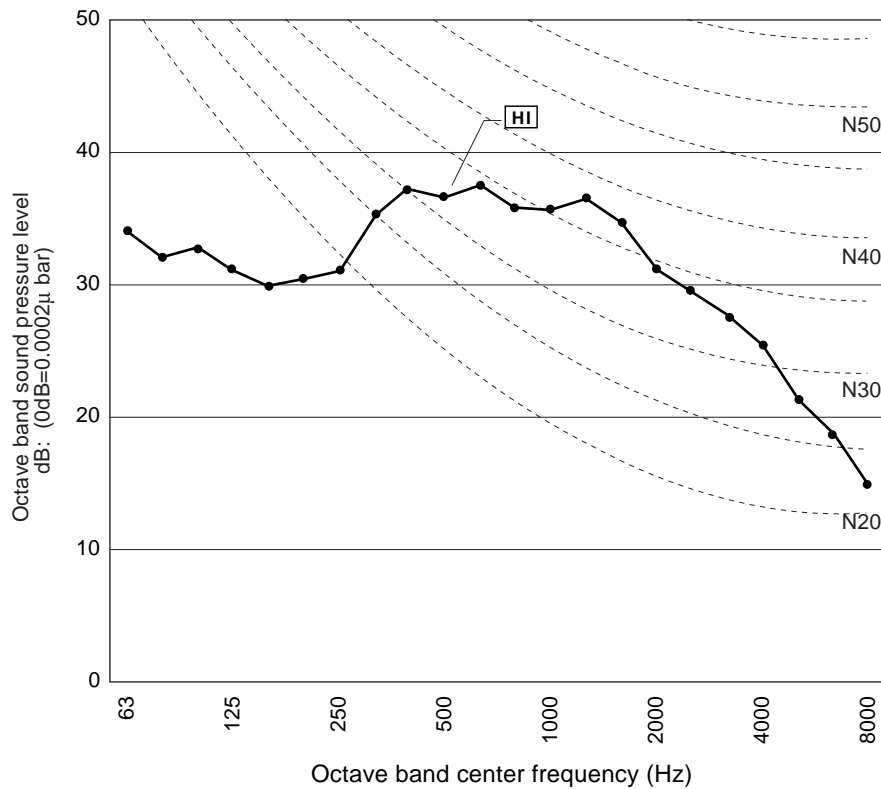



**AS□30ABA-W**  
(COOL)

240V COOL

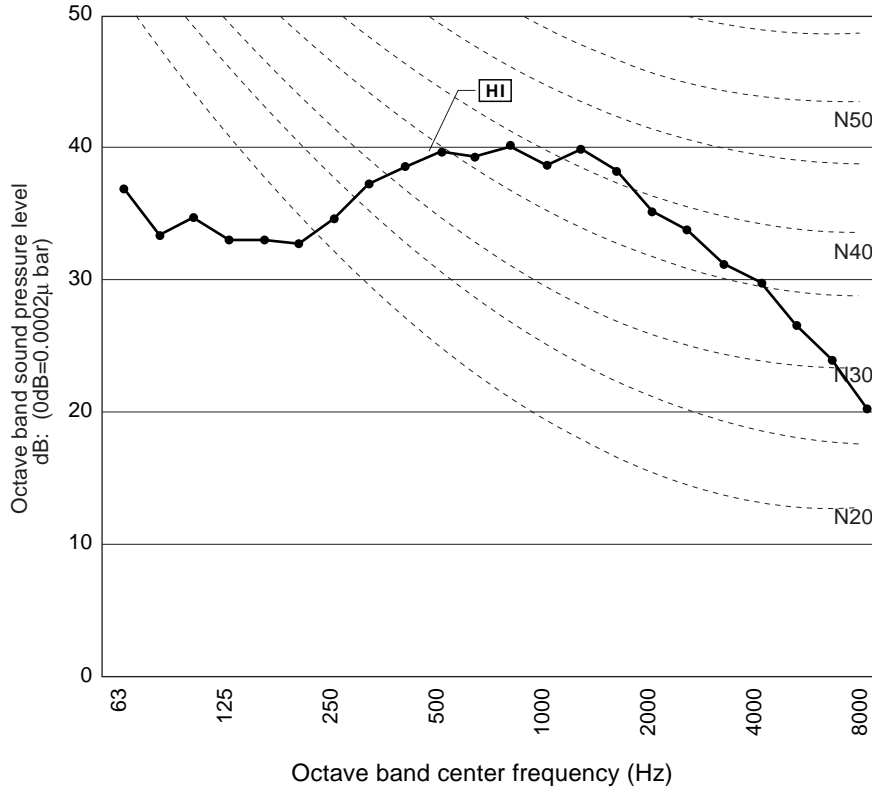

**AW□14RBA**  
(COOL)

240V COOL

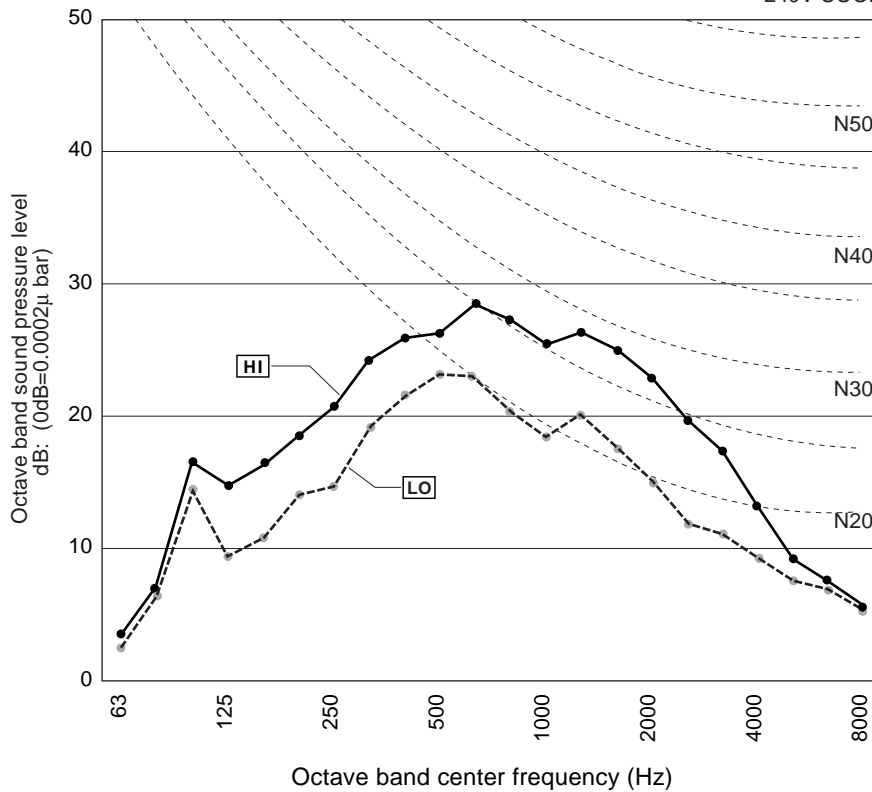

**AW□18RBA-W**  
(COOL)

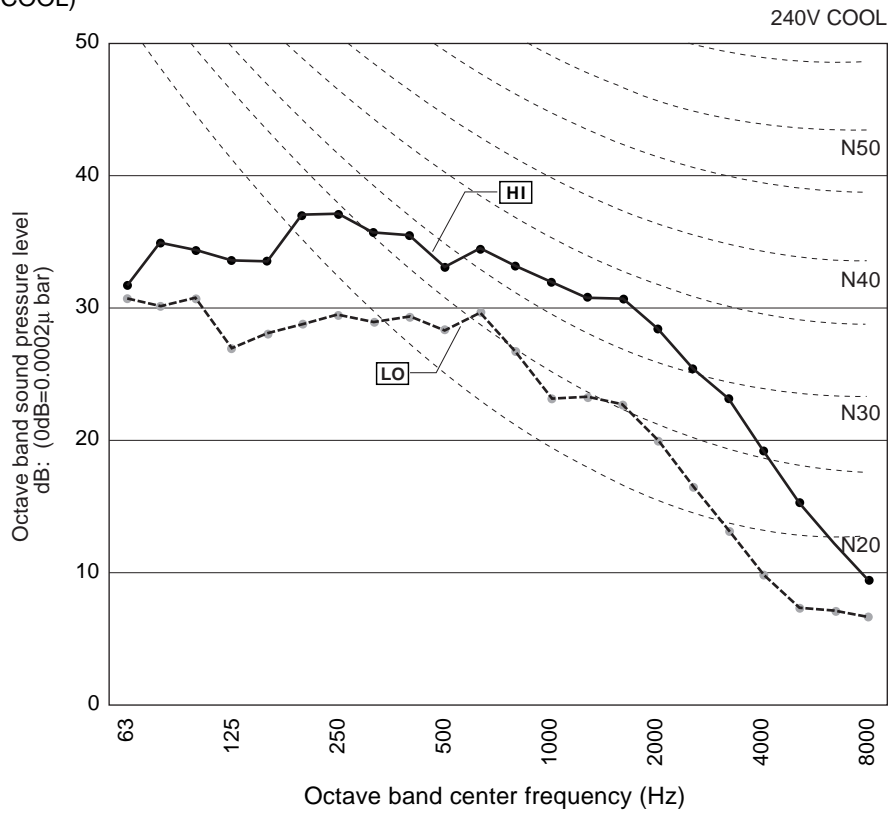

**AW□24RBA-W**  
(COOL)

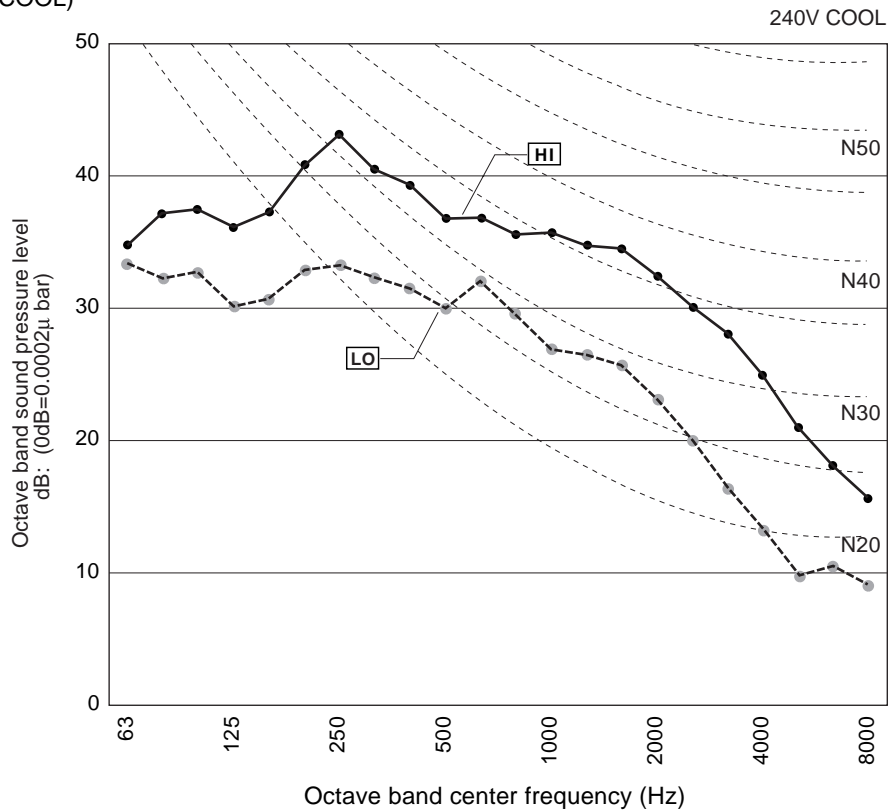

**AW□30RBA-W**  
(COOL)

240V COOL

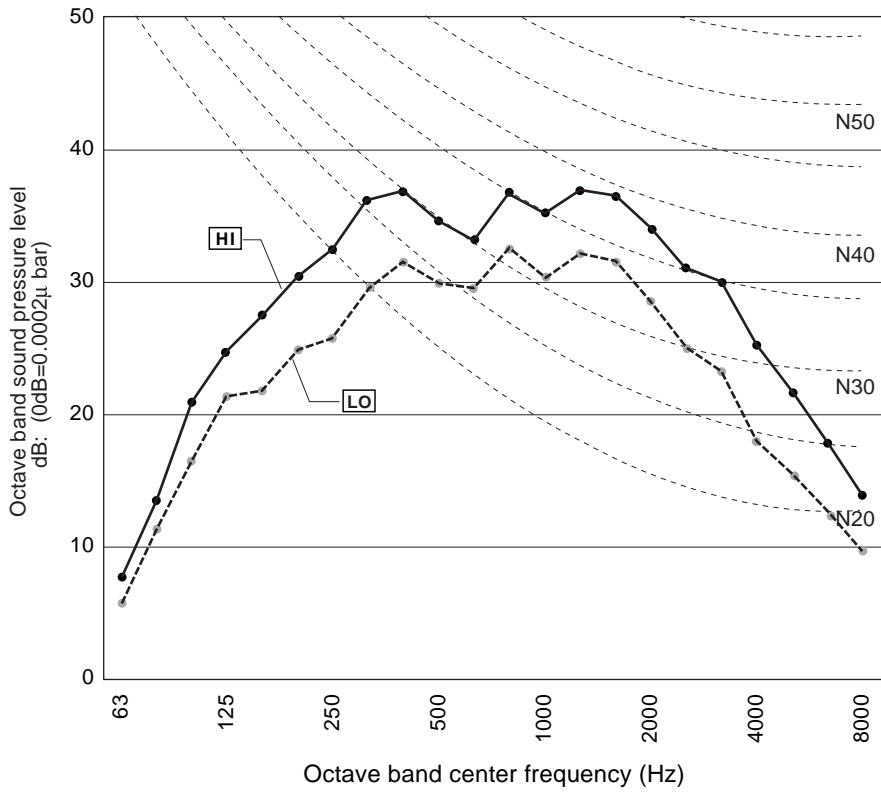

# 10.2 OUTDOOR UNIT

## AO□14RG (COOL)

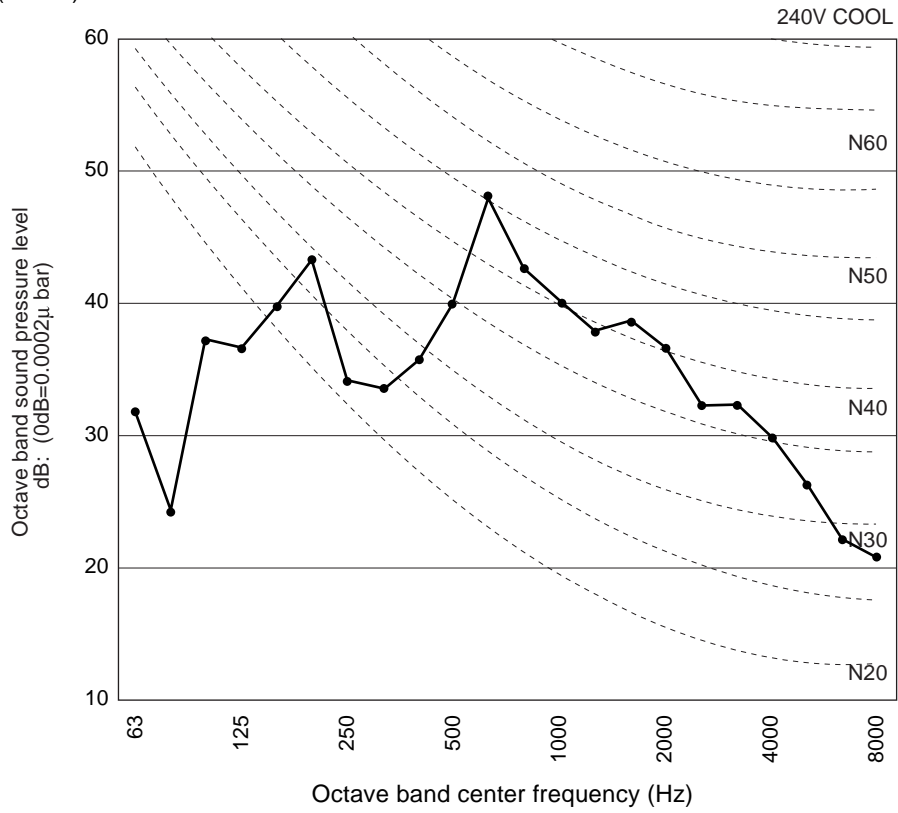

## AO□18AN (COOL)

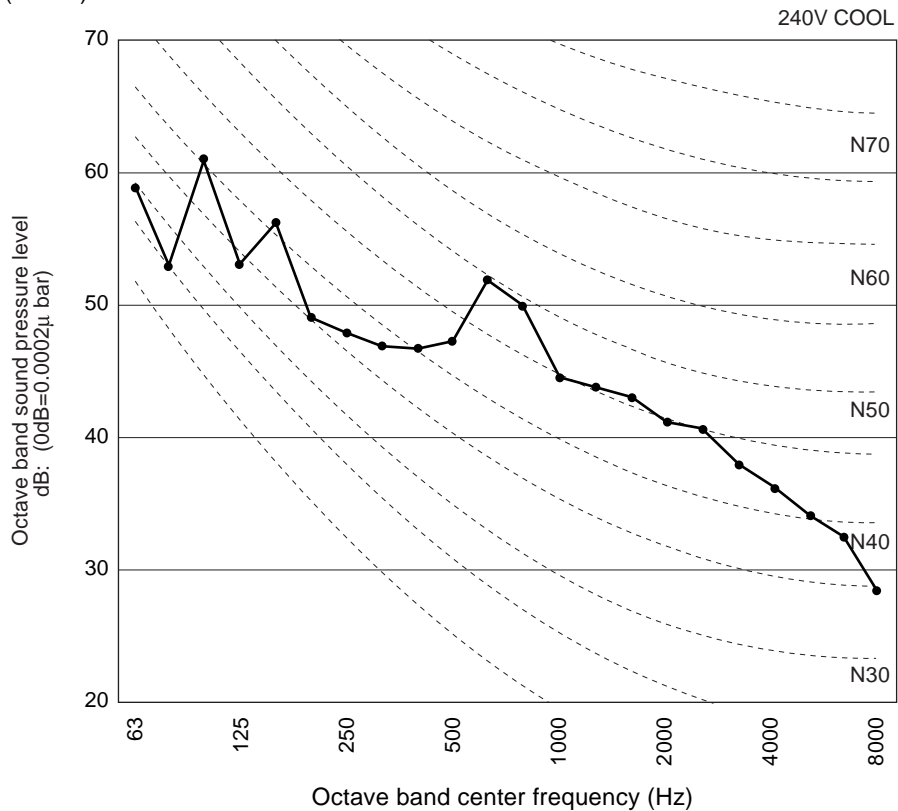

**AO□24AM**  
(COOL)

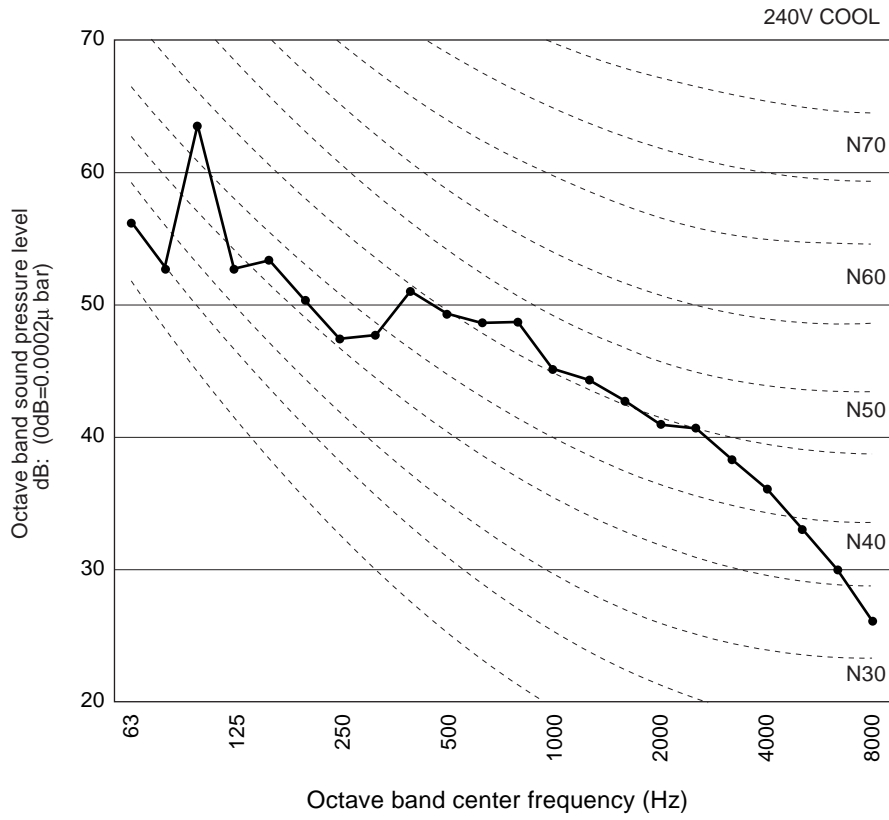

**AO□30AM**  
(COOL)

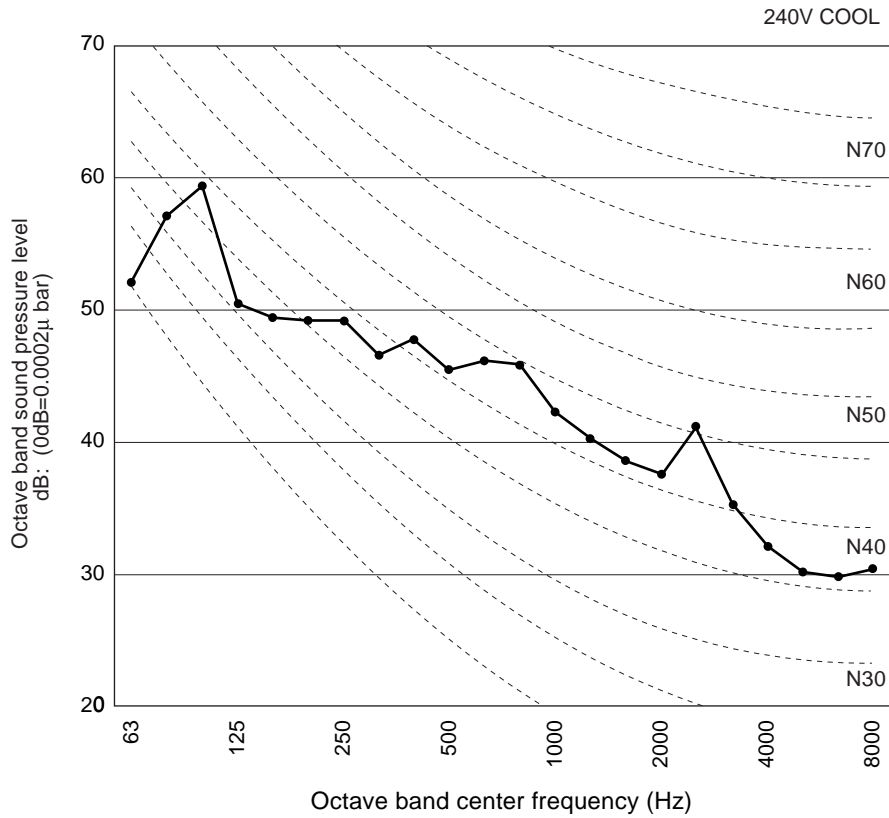

**FUJITSU GENERAL LIMITED**  
1116, Suenaga, Takatsu-ku, Kawasaki 213-8502, Japan