

Multi Air Conditioning System for Buildings

SIMULTANEOUS OPERATION / INDIVIDUAL OPERATION

SYSTEM MANUAL



FUJITSU GENERAL LIMITED

Multi Air Conditioning System for Buildings

SIMULTANEOUS OPERATION / INDIVIDUAL OPERATION

SYSTEM MANUAL

CONTENTS

1. FEATURES OF SYSTEM OPERATION

1 - 1. SIMULTANEOUS OPERATION	
FEATURES	1
1 - 2. INDIVIDUAL OPERATION	
FEATURES	9

2. FEATURES

2 - 1. OUTDOOR UNIT ----- AO90	15
2 - 2. INDOOR UNITS	
(1) UNIVERSAL FLOOR / CEILING TYPE ----- AB18, AB24	17
(2) LARGE CEILING TYPE ----- AB30, AB36, AB45	18
(3) DUCT TYPE ----- AR25, AR30, AR36, AR45	19
(4) HIGH STATIC PRESSURE DUCT TYPE ----- AR36H, AR45H	20
(5) COMPACT CASSETTE TYPE ----- AU18	21
(6) CASSETTE TYPE ----- AU25, AU30, AU36, AU45	22
2 - 3. REMOTE CONTROLLER	24

3. DATA

3 - 1. DIMENSIONS	
OUTDOOR UNIT ----- AO90	26
INDOOR UNIT	
UNIVERSAL FLOOR / CEILING TYPE ----- AB18, AB24	27
LARGE CEILING TYPE ----- AB30, AB36, AB45	28
DUCT TYPE ----- AR25, AR30, AR36, AR45	29
HIGH STATIC PRESSURE DUCT TYPE ----- AR36H, AR45H	30
COMPACT CASSETTE TYPE ----- AU18	31
CASSETTE TYPE ----- AU25, AU30, AU36, AU45	32
3 - 2. SPECIFICATIONS	
OUTDOOR UNIT	33
INDOOR UNIT	35
3 - 3. PERFORMANCE CURVES	
INDOOR UNIT (COOLING / HEATING)	39
3 - 4. AIR VELOCITY DISTRIBUTION	
UNIVERSAL FLOOR / CEILING TYPE ----- AB18	40
LARGE CEILING TYPE ----- AB30	44
COMPACT CASSETTE TYPE ----- AU18	47
CASSETTE TYPE ----- AU25, AU30, AU36, AU45	48
3 - 5. SOUND LEVEL CURVES	
UNIVERSAL FLOOR / CEILING, CEILING TYPE	
----- AB18, AB24, AB30, AB36, AB45	52
COMPACT CASSETTE TYPE	
----- AU18, AU25, AU30, AU36, AU45	53

3 - 6. REFRIGERANT CHARGING	54
3 - 7. FRESH AIR	
LARGE CEILING TYPE ----- AB30, AB36, AB45 -----	55
COMPACT CASSETTE TYPE ----- AU18	56
CASSETTE TYPE ----- AU30, AU36, AU45	56
3 - 8. OUTLET AIR	
COMPACT CASSETTE TYPE ----- AU18	57
CASSETTE TYPE ----- AU30, AU36, AU45	57
3 - 9. TEMPERATURE RANG	
COOL (DRY) / HEAT	58
3 - 10. OTHERS	
FAN CURVE ----- AR25, AR36, AR45	59
FAN CURVE ----- AR36, AR45	60
CAPACITY BY AIR FLOW ----- AR25	61
CAPACITY BY AIR FLOW ----- AR36, AR45	62
OUTLET AIR TEMPERATURE ----- AR25	63
OUTLET AIR TEMPERATURE ----- AR36, AR45	64

4. SYSTEM DESIGN RESTRICTIONS

4 - 1. OUTDOOR UNIT INSTALLATION	65
----------------------------------	----

5. OPTIONAL (SERVICE) PARTS

5 - 1. OPTIONAL (SERVICE) PARTS FOR BUILDING SYSTEM	66
5 - 2. RECOMMENDED SHAPES OF EACH DUCT	66
5 - 3. OPTIONAL PARTS FOR DUCT TYPE	67

DESIGNATION

6 - 1. OUTDOOR UNIT / INDOOR UNIT	68
-----------------------------------	----

1. FEATURES OF SYSTEM OPERATION

1 - 1. SIMULTANEOUS OPERATION

FEATURES :

- Simultaneous Operating System suitable for large spaces such as offices, lobbies or waiting rooms of high-rise buildings.
- One controller can simultaneously control cooling or heating by 2~4 indoor units.

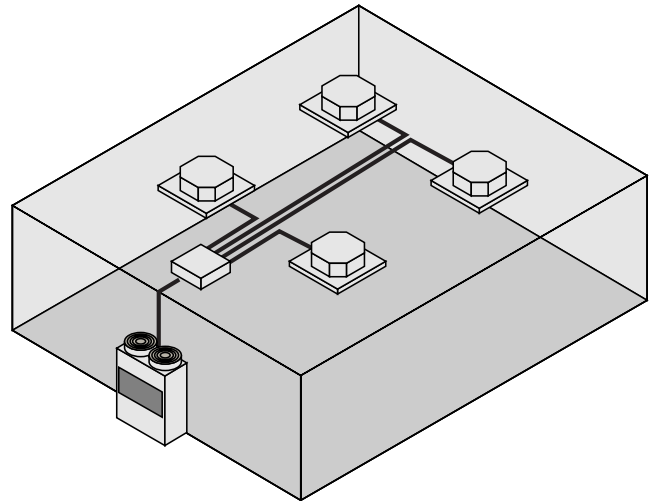

- (1) Long piping for high-rise buildings
- (2) Various combinations of indoor unit type and capacity
- (3) Centralized control by wire remote controller with weekly timer
- (4) Space saving
- (5) Easy installation
- (6) Cooling & heating at low outdoor temperatures

(1) Long piping for high-rise buildings

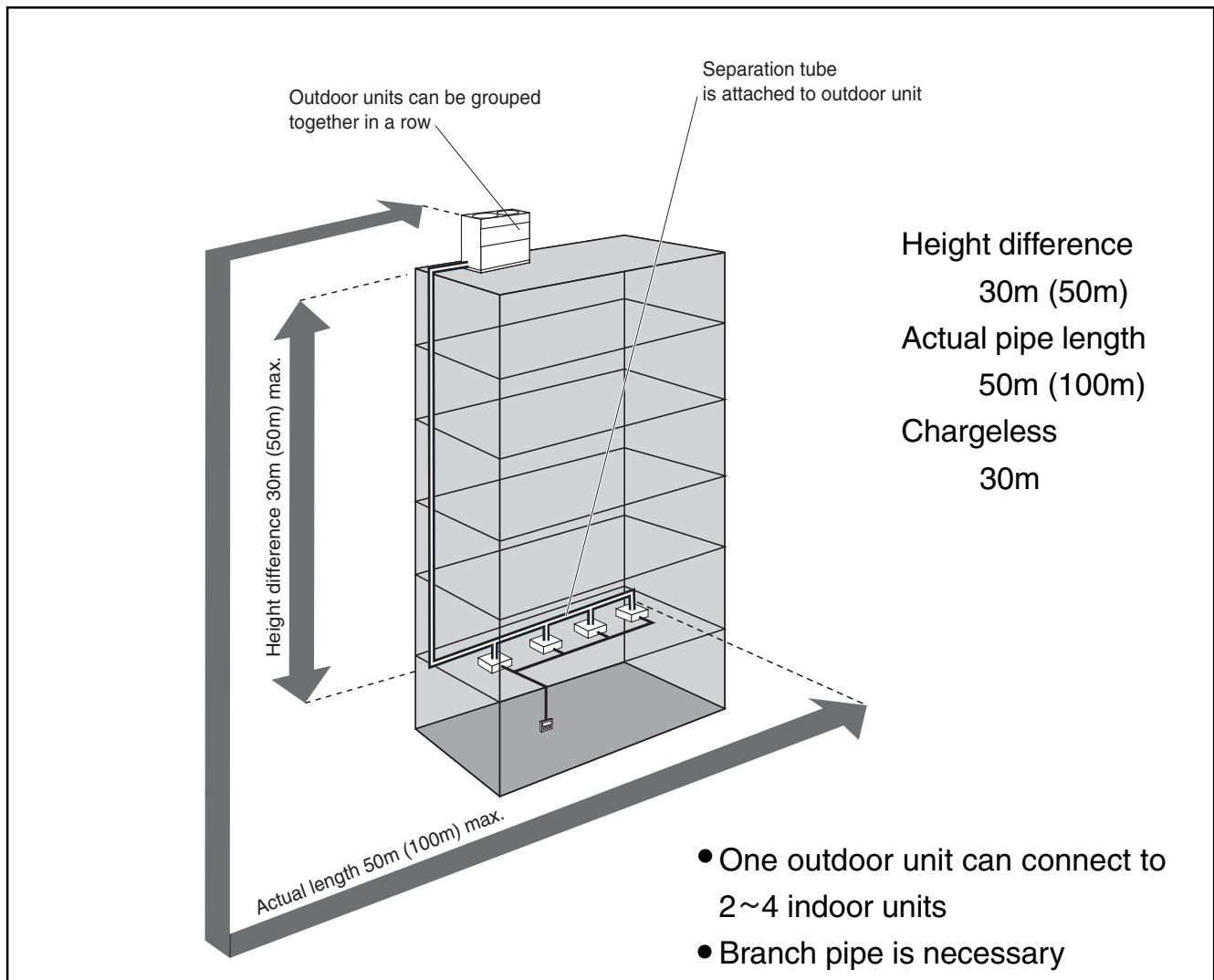

Connection Pipe Length (Allowable length of connection pipe)

Two Indoor Units

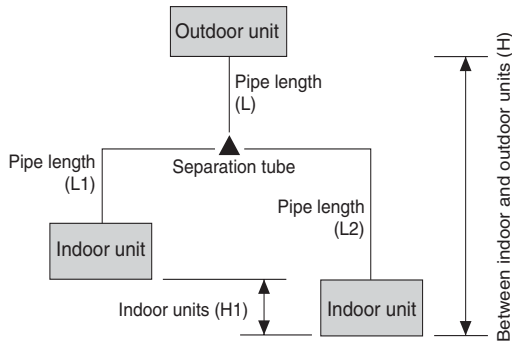

(unit: m)

Total length $L + L1 + L2$	—
Maximum allowable length $L + L1, L + L2$	50 (100)
Length after branch $L1, L2$	10
Difference length after branch $L1 - L2$	5
Between indoor and outdoor units (H)	30 (50)
Indoor units (H1)	0.5

Three Indoor Units

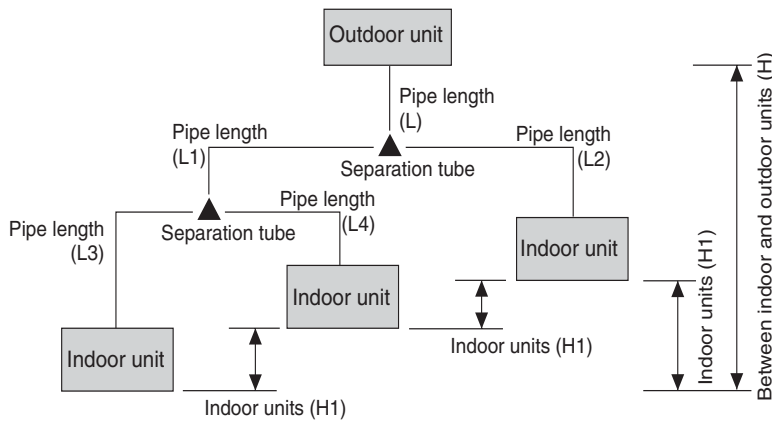

(unit: m)

Total length $L + L1 + L2 + L3 + L4$	—
Maximum allowable length $L + L1 + L3, L + L1 + L4, L + L2$	50 (100)
Maximum length after branch $L1 + L3, L1 + L4, L2$	10
After branch $(L1 + L3) - L2, (L1 + L4) - L2$	5
After branch $(L3 - L4)$	5
Between indoor and outdoor units (H)	30 (50)
Between indoor units (H1)	0.5 ※

※ Acceptable to 3m only when used with AB (Floor console) type indoor unit.

Four Indoor Units

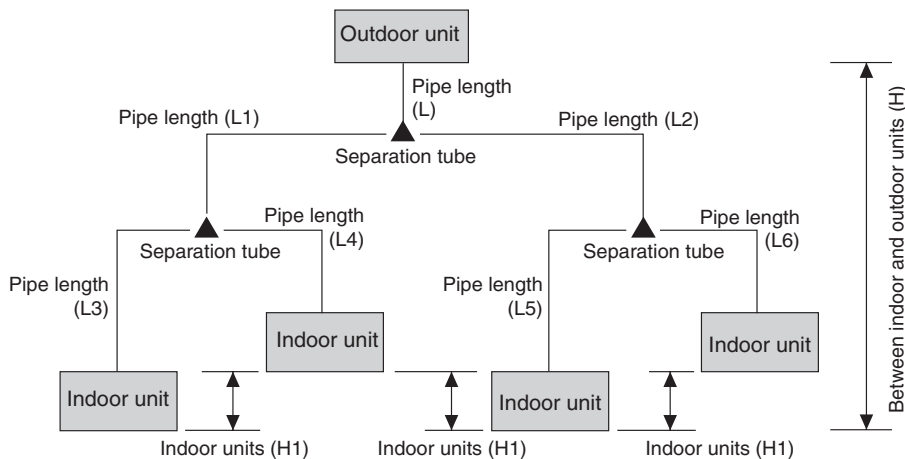

(unit: m)

Total length $L + L1 + L2 + L3 + L4 + L5 + L6$	—
Maximum allowable length $L + L1 + L3, L + L1 + L4, L + L2 + L5, L + L2 + L6$	50 (100)
Maximum length after branch $L1 + L3, L1 + L4, L2 + L5, L2 + L6$	10
After branch $(L1 + L3) - (L2 + L5), (L1 + L4) - (L2 + L5), (L1 + L3) - (L2 + L6), (L1 + L4) - (L2 + L6)$	5
After branch $(L3 - L4)$	5
Between indoor and outdoor units (H)	30 (50)
Between indoor units (H1)	0.5 ※

※ Acceptable to 3m only when used with AB (Floor console) type indoor unit.

(2) Various Combinations of Indoor Unit Type and Capacity

Simultaneous Operation

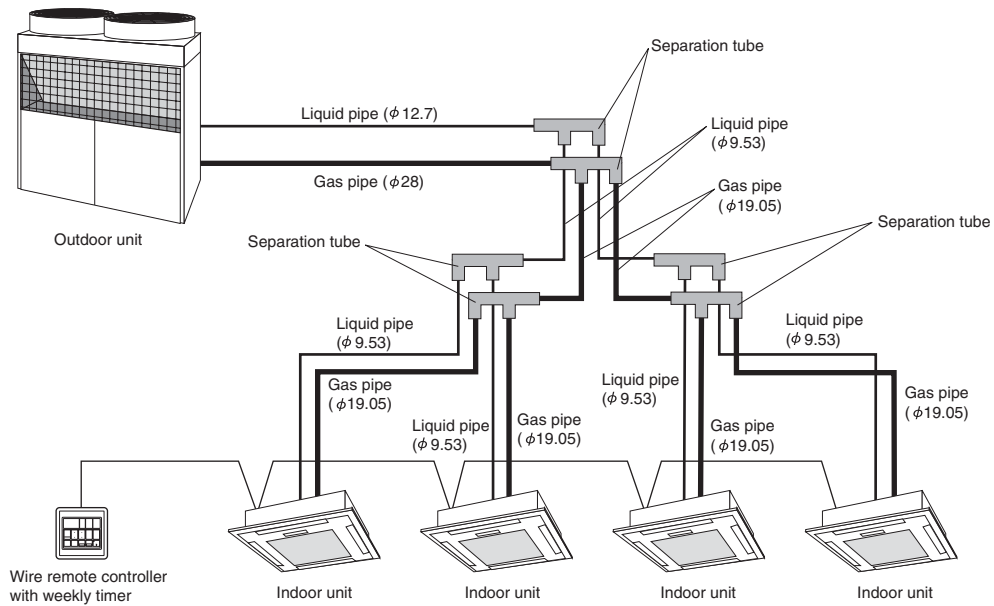



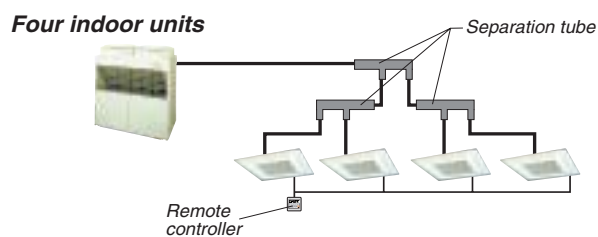
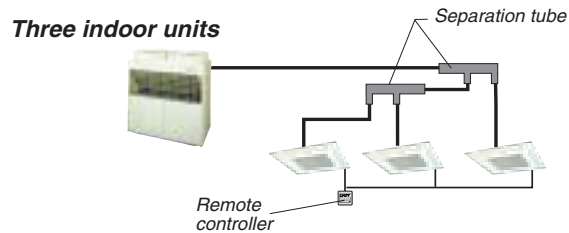
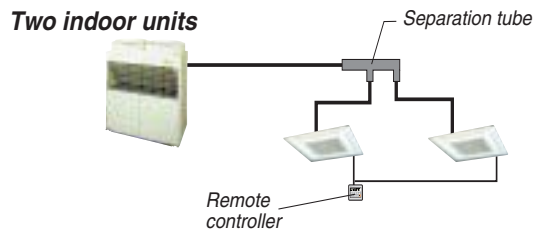

Cooling or Heating

Piping pattern variations



Indoor Units Line-up

Simultaneous Operation

Capacity (BTU)	Cassette (Compact)	Cassette	Duct	Ceiling/Floor	Ceiling
					
45,000		●	●		●
36,000		●	●		●
30,000		●	●		●
24,000 (25,000)		●	●	●	
18,000	●			●	

Indoor Unit Combinations

Two

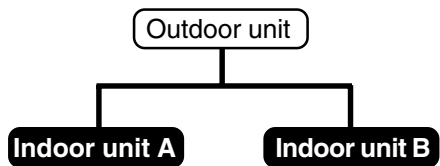

Two 45 + 45

System No.	Indoor unit A	Indoor unit B
Two 1	AU45	AU45
Two 2	AU45	AB45
Two 3	AU45	AR45(L)
Two 4	AU45	AR45(H)
Two 5	AB45	AB45
Two 6	AB45	AR45(L)
Two 7	AB45	AR45(H)
Two 8	AR45(L)	AR45(L)
Two 9	AR45(L)	AR45(H)
Two 10	AR45(H)	AR45(H)

Three

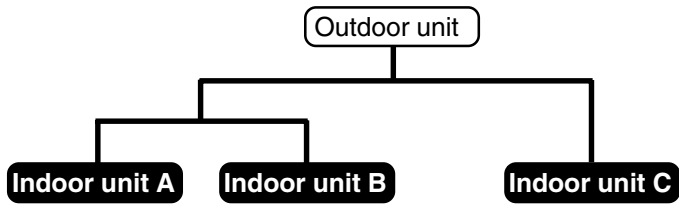

Three 24 + 24 + 45

System No.	Indoor unit A	Indoor unit B	Indoor unit C
Three 1	AU25	AU25	AU45
Three 2	AU25	AB24	AU45
Three 3	AU25	AR25	AU45
Three 4	AB24	AB24	AU45
Three 5	AB24	AR25	AU45
Three 6	AR25	AR25	AU45
Three 7	AU25	AU25	AB45
Three 8	AU25	AB24	AB45
Three 9	AU25	AR25	AB45
Three 10	AB24	AB24	AB45
Three 11	AB24	AR25	AB45
Three 12	AR25	AR25	AB45
Three 13	AU25	AU25	AR45(L)
Three 14	AU25	AB24	AR45(L)
Three 15	AU25	AR25	AR45(L)
Three 16	AB24	AB24	AR45(L)
Three 17	AB24	AR25	AR45(L)
Three 18	AR25	AR25	AR45(L)
Three 19	AU25	AU25	AR45(H)
Three 20	AU25	AB24	AR45(H)
Three 21	AU25	AR25	AR45(H)
Three 22	AB24	AB24	AR45(H)
Three 23	AB24	AR25	AR45(H)
Three 24	AR25	AR25	AR45(H)

Three 30 + 30 +30

System No.	Indoor unit A	Indoor unit B	Indoor unit C
Three 25	AU30	AU30	AU30
Three 26	AU30	AU30	AB30
Three 27	AU30	AU30	AR30
Three 28	AU30	AB30	AB30
Three 29	AU30	AB30	AR30
Three 30	AU30	AR30	AR30
Three 31	AB30	AB30	AB30
Three 32	AB30	AB30	AR30
Three 33	AR30	AR30	AR30

Three 18 + 30 + 45

System No.	Indoor unit A	Indoor unit B	Indoor unit C
Three 34	AU18	AU30	AU45
Three 35	AU18	AU30	AB45
Three 36	AU18	AU30	AR45(L)
Three 37	AU18	AU30	AR45(H)
Three 38	AU18	AB30	AU45
Three 39	AU18	AB30	AB45
Three 40	AU18	AB30	AR45(L)
Three 41	AU18	AB30	AR45(H)
Three 42	AU18	AR30	AU45
Three 43	AU18	AR30	AB45
Three 44	AU18	AR30	AR45(L)
Three 45	AU18	AR30	AR45(H)
Three 46	AB18	AU30	AU45
Three 47	AB18	AU30	AB45
Three 48	AB18	AU30	AR45(L)
Three 49	AB18	AU30	AR45(H)
Three 50	AB18	AB30	AU45
Three 51	AB18	AB30	AB45
Three 52	AB18	AB30	AR45(L)
Three 53	AB18	AB30	AR45(H)
Three 54	AB18	AR30	AU45
Three 55	AB18	AR30	AB45
Three 56	AB18	AR30	AR45(L)
Three 57	AB18	AR 30	AR45(H)

Three 24 + 30 + 36

System No.	Indoor unit A	Indoor unit B	Indoor unit C
Three 79	AU25	AU30	AU36
Three 80	AU25	AU30	AB36
Three 81	AU25	AU30	AR36(L)
Three 82	AU25	AU30	AR36(H)
Three 83	AU25	AB30	AU36
Three 84	AU25	AB30	AB36
Three 85	AU25	AB30	AR36(L)
Three 86	AU25	AB30	AR36(H)
Three 87	AU25	AR30	AU36
Three 88	AU25	AR30	AB36
Three 89	AU25	AR30	AR36(L)
Three 90	AU25	AR30	AR36(H)
Three 91	AU24	AU30	AU36
Three 92	AU24	AU30	AB36
Three 93	AU24	AU30	AR36(L)
Three 94	AU24	AU30	AR36(H)
Three 95	AU24	AB30	AU36
Three 96	AU24	AB30	AB36
Three 97	AU24	AB30	AR36(L)
Three 98	AU24	AB30	AR36(H)
Three 99	AU24	AR30	AU36
Three 100	AU24	AR30	AB36
Three 101	AU24	AR30	AR36(L)
Three 102	AU24	AR30	AR36(H)
Three 103	AU25	AU30	AU36
Three 104	AU25	AU30	AB36
Three 105	AU25	AU30	AR36(L)
Three 106	AU25	AU30	AR36(H)
Three 107	AU25	AB30	AU36
Three 108	AU25	AB30	AB36
Three 109	AU25	AB30	AR36(L)
Three 110	AU25	AB30	AR36(H)
Three 111	AU25	AR30	AU36
Three 112	AU25	AR30	AB36
Three 113	AU25	AR30	AR36(L)
Three 114	AU25	AR30	AR36(H)

Three 18 + 36 + 36

System No.	Indoor unit A	Indoor unit B	Indoor unit C
Three 59	AU18	AU36	AU36
Three 60	AU18	AU36	AB36
Three 61	AU18	AU36	AR36(L)
Three 62	AU18	AU36	AR36(H)
Three 63	AU18	AB36	AB36
Three 64	AU18	AB36	AR36(L)
Three 65	AU18	AB36	AR36(H)
Three 66	AU18	AR36(L)	AR36(L)
Three 67	AU18	AR36(L)	AR36(H)
Three 68	AU18	AR36(H)	AR36(H)
Three 69	AB18	AU36	AU36
Three 70	AB18	AU36	AB36
Three 71	AB18	AU36	AR36(L)
Three 72	AB18	AU36	AR36(H)
Three 73	AB18	AB36	AB36
Three 74	AB18	AB36	AR36(L)
Three 75	AB18	AB36	AR36(H)
Three 76	AB18	AR36(L)	AR36(L)
Three 77	AB18	AR36(L)	AR36(H)
Three 78	AB18	AR36(H)	AR36(H)

Four

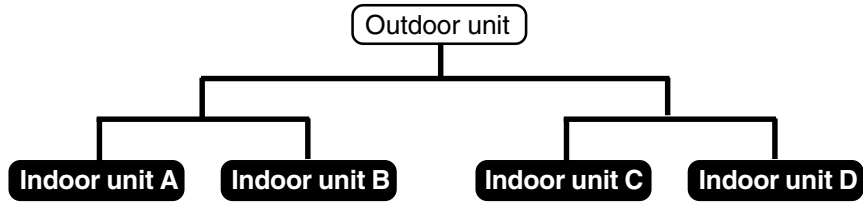

Four 24 + 24 + 24 +24

System No.	Indoor unit A	Indoor unit B	Indoor unit C	Indoor unit D
Four 1	AU25	AU25	AU25	AU25
Four 2	AU25	AU25	AU25	AB24
Four 3	AU25	AU25	AU25	AR25
Four 4	AU25	AU25	AB24	AB24
Four 5	AU25	AU25	AB24	AR25
Four 6	AU25	AU25	AR25	AR25
Four 7	AU25	AB24	AB24	AB24
Four 8	AU25	AB24	AB24	AR25
Four 9	AU25	AR25	AR25	AR25
Four 10	AB24	AU25	AR25	AR25
Four 11	AB24	AB24	AB24	AB24
Four 12	AB24	AB24	AB24	AR25
Four 13	AB24	AR25	AR25	AR25
Four 14	AR25	AU25	AB24	AR25
Four 15	AR25	AB24	AB24	AR25
Four 16	AR25	AR25	AR25	AR25

Four 18 + 18 + 18 +36

System No.	Indoor unit A	Indoor unit B	Indoor unit C	Indoor unit D
Four 17	AU18	AU18	AU18	AU36
Four 18	AU18	AU18	AU18	AB36
Four 19	AU18	AU18	AU18	AR36(L)
Four 20	AU18	AU18	AU18	AR36(H)
Four 21	AU18	AU18	AB18	AU36
Four 22	AU18	AU18	AB18	AB36
Four 23	AU18	AU18	AB18	AR36(L)
Four 24	AU18	AU18	AB18	AR36(H)
Four 25	AU18	AB18	AB18	AU36
Four 26	AU18	AB18	AB18	AB36
Four 27	AU18	AB18	AB18	AR36(L)
Four 28	AU18	AB18	AB18	AR36(H)
Four 29	AB18	AB18	AB18	AU36
Four 30	AB18	AB18	AB18	AB36
Four 31	AB18	AB18	AB18	AR36(L)
Four 32	AB18	AB18	AB18	AR36(H)

Four 18 + 24 + 18 + 30

System No.	Indoor unit A	Indoor unit B	Indoor unit C	Indoor unit D
Four 33	AU18	AU25	AU18	AU30
Four 34	AU18	AU25	AU18	AB30
Four 35	AU18	AU25	AU18	AR30
Four 36	AU18	AR25	AU18	AU30
Four 37	AU18	AR25	AU18	AB30
Four 38	AU18	AR25	AU18	AR30
Four 39	AU18	AB24	AU18	AU30
Four 40	AU18	AB24	AU18	AB30
Four 41	AU18	AB24	AU18	AR30
Four 42	AU18	AU25	AB18	AU30
Four 43	AU18	AU25	AB18	AB30
Four 44	AU18	AU25	AB18	AR30
Four 45	AU18	AR25	AB18	AU30
Four 46	AU18	AR25	AB18	AB30
Four 47	AU18	AR25	AB18	AR30
Four 48	AU18	AB24	AB18	AU30
Four 49	AU18	AB24	AB18	AB30
Four 50	AU18	AB24	AB18	AR30
Four 51	AB18	AU25	AB18	AU30
Four 52	AB18	AU25	AB18	AB30
Four 53	AB18	AU25	AB18	AR30
Four 54	AB18	AR25	AB18	AU30
Four 55	AB18	AR25	AB18	AB30
Four 56	AB18	AR25	AB18	AR30
Four 57	AB18	AB24	AB18	AU30
Four 58	AB18	AB24	AB18	AB30
Four 59	AB18	AB24	AB18	AR30

(3) Centralized control by wire remote controller with weekly timer

Cooling

Indoor unit Indoor unit Indoor unit Indoor unit

Wire remote controller with weekly timer

Heating

Indoor unit Indoor unit Indoor unit Indoor unit

Wire remote controller with weekly timer

Example: Office

Weekly schedule

Sun	Mon	Tue	Wed	Thu	Fri	Sat
-----	-----	-----	-----	-----	-----	-----

Operation: On time 8:00 ~ 12:00
On time 14:00 ~ 19:00

(4) Space Saving (See page 18 for details)

Height

Width

Depth

Dimensions
Height 1,380
Width 1,300
Depth 650 (Unit : mm)

Conventional model

18,000BTU + (36,000BTU x 2)
-52 % wide

45,000BTU x 2
-31 % wide

24,000BTU x 4
-61 % wide

(5) Easy installation (See page 18 for details)

Outdoor unit goes into elevator

Outdoor unit can be lifted by a crane set on the roof of the building

Five-direction pipe

Five-direction pipe allows a variety of installation, configurations.
Easy installation and pipe direction setting

(6) Cooling or heating at low outdoor temperatures

Cooling Possible at Low Outdoor-temperature 0°C

Heating Possible at Low Outdoor-temperature -10°C

1 - 2. INDIVIDUAL OPERATION

FEATURES :

- Individual Operating System is suitable for large spaces such as hotels, commercial spaces, offices and restaurants.
- The system can cool and heat individually, because the system has two refrigeration cycles.

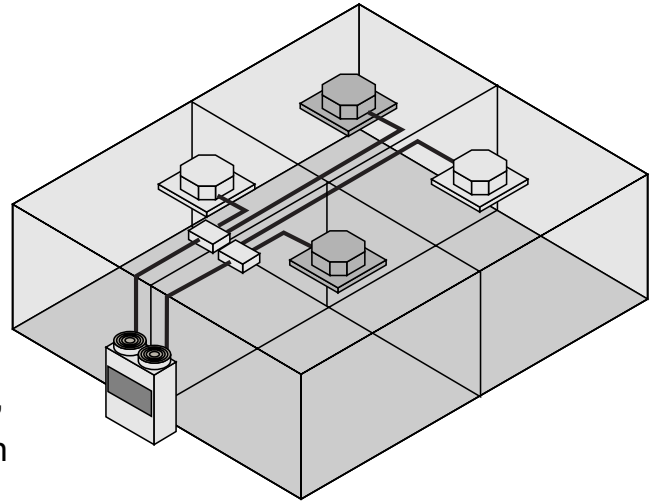

- (1) Two refrigeration cycles
- (2) Various combinations of indoor unit type and capacity
- (3) Centralized control by wire remote controller with weekly timer
- (4) Space saving
- (5) Easy installation
- (6) Cooling & heating at low outdoor temperatures

(1) Two refrigeration cycles

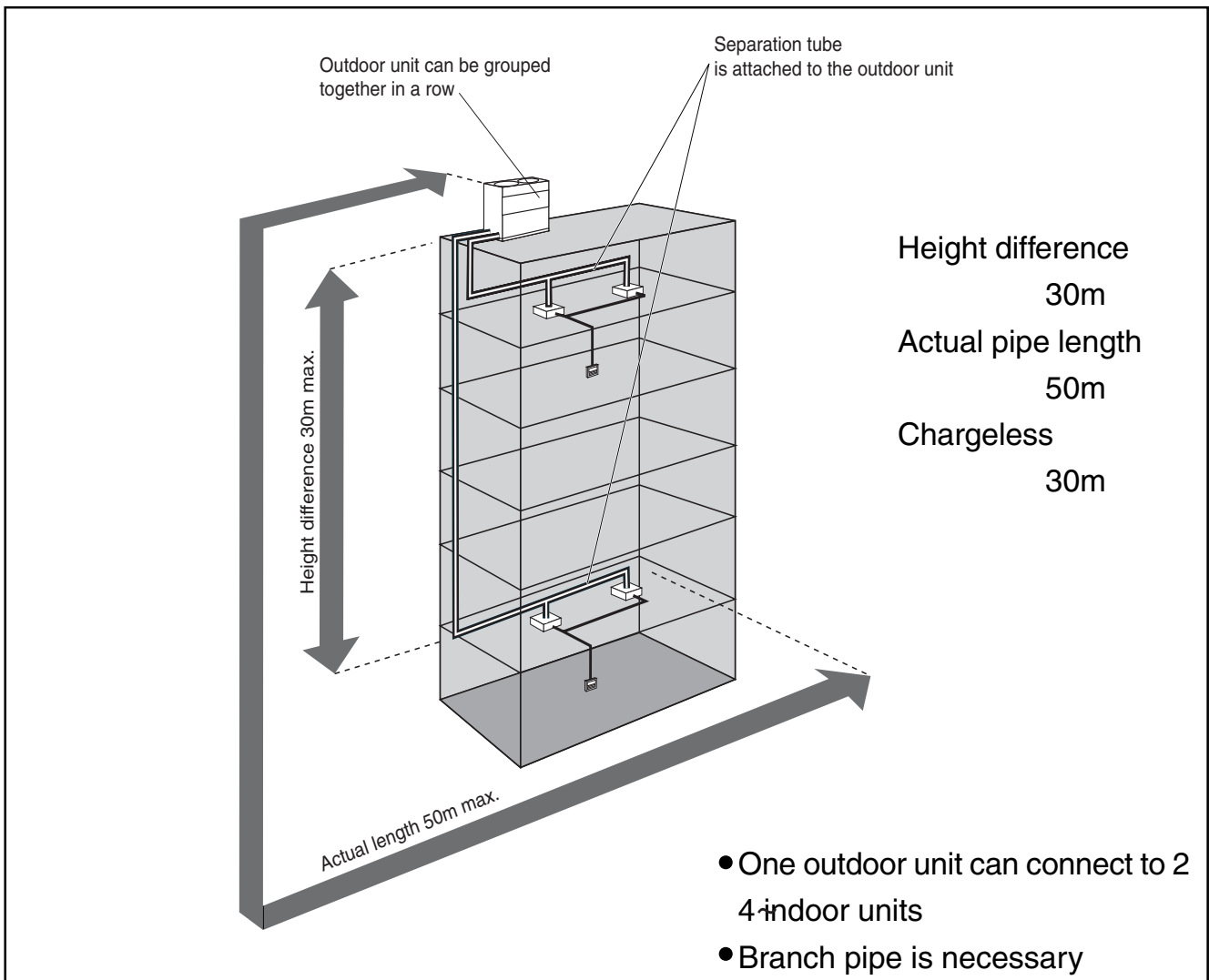

Connection Pipe Length (Allowable length of connection pipe)

One + One

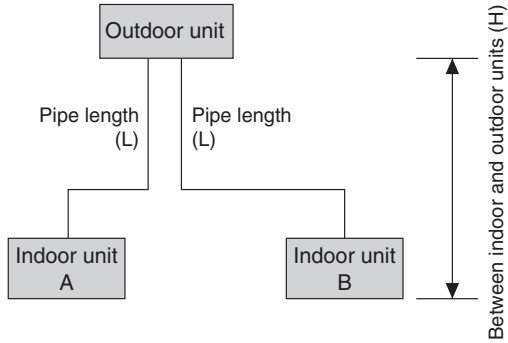

(unit: m)

Maximum length (L)	50
Between indoor and outdoor units (H)	30

One + Two

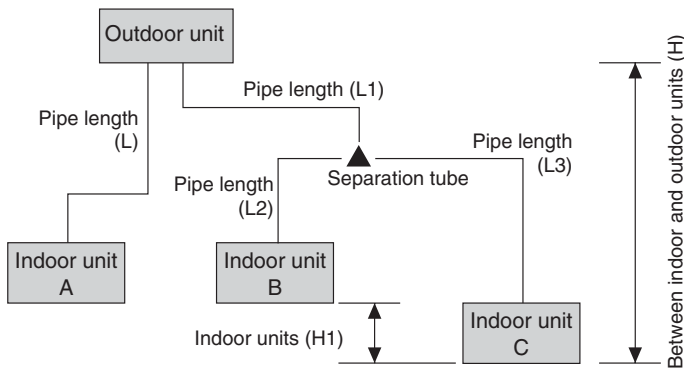

(unit: m)

Total length $L + L1 + L2$	—
Maximum allowable length $L1 + L2, L2 + L3$	50
Length after branch $L2, L3$	10
Difference length after branch $L2 - L3$	5
Between indoor and outdoor units (H)	30
Between indoor units (H1)	0.5 ※

※ Acceptable to 3m only when used with AB (floor console) type indoor unit.

Two + Two

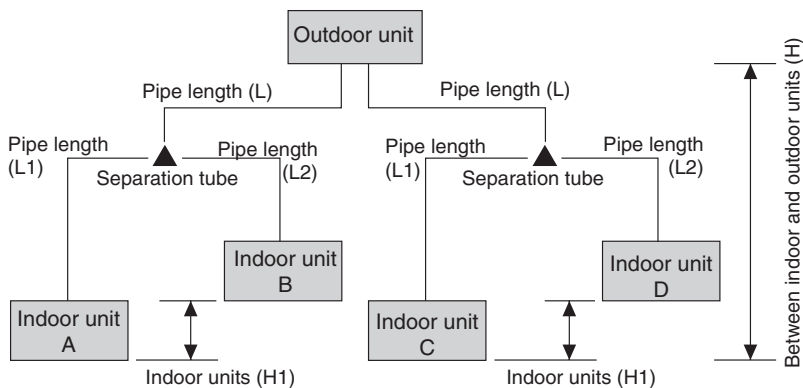

(unit: m)

Total length $L + L1 + L2$	—
Maximum allowable length $L + L1, L + L2$	50
Length after branch $L1, L2$	10
Difference length after branch $L1 - L2$	5
Between Indoor and outdoor units (H)	30
Between Indoor units (H1)	0.5 ※

※ Acceptable to 3m only when used with AB (four console) type indoor unit.

(2) Various Combinations of Indoor Unit Type and Capacity

Individual Operation

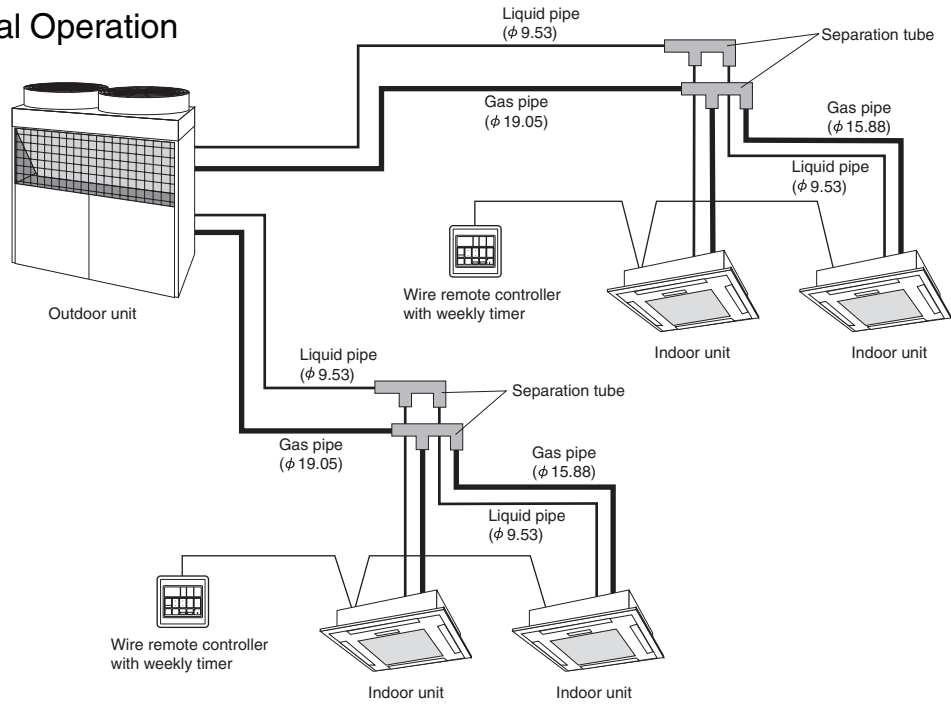

Cooling or Heating

Cooling & Heating

One + One

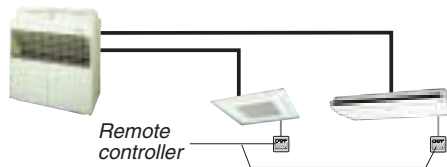

One + Two

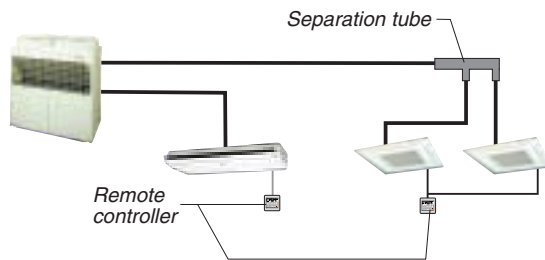



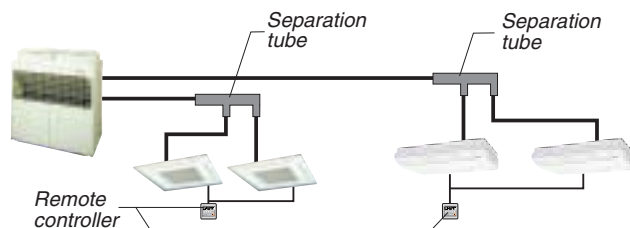

Two + Two



Indoor Units Line-up

Individual Operation

Capacity (BTU)	Cassette (Compact)	Cassette	Duct	Ceiling/Floor	Ceiling
					
45,000		●	●		●
30,000		●	●		●
24,000 (25,000)		●	●	●	
18,000	●			●	

One + One

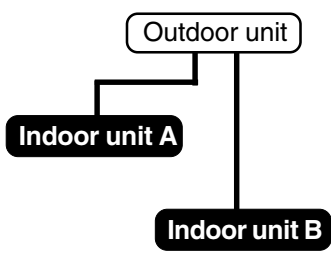

System No.	Indoor unit A	Indoor unit B
One + One 1	AU45	AU45
One + One 2	AU45	AB45
One + One 3	AU45	AR45(L)
One + One 4	AU45	AR45(H)
One + One 5	AB45	AB45
One + One 6	AB45	AR45(L)
One + One 7	AB45	AR45(H)
One + One 8	AR45(L)	AR45(L)
One + One 9	AR45(L)	AR45(H)
One + One 10	AR45(H)	AR45(H)

One + Two

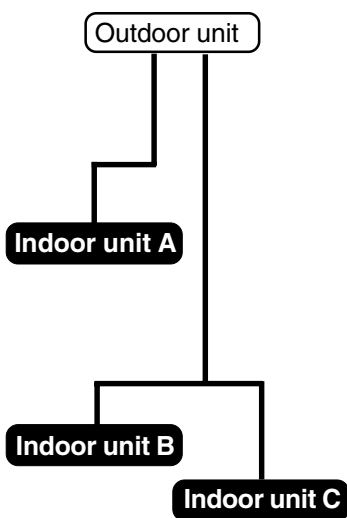

45 + 24 + 24

System No.	Indoor unit A	Indoor unit B	Indoor unit C
One + Two 1	AU45	AU25	AU25
One + Two 2	AU45	AU25	AB24
One + Two 3	AU45	AU25	AR25
One + Two 4	AU45	AB24	AB24
One + Two 5	AU45	AB24	AR25
One + Two 6	AU45	AR25	AR25
One + Two 7	AB45	AU25	AU25
One + Two 8	AB45	AU25	AB24
One + Two 9	AB45	AU25	AR25
One + Two 10	AB45	AB24	AB24
One + Two 11	AB45	AB24	AR25
One + Two 12	AB45	AR25	AR25
One + Two 13	AR45(L)	AU25	AU25
One + Two 14	AR45(L)	AU25	AB24
One + Two 15	AR45(L)	AU25	AR25
One + Two 16	AR45(L)	AB24	AB24
One + Two 17	AR45(L)	AB24	AR25
One + Two 18	AR45(L)	AR25	AR25
One + Two 19	AR45(H)	AU25	AU25
One + Two 20	AR45(H)	AU25	AB24
One + Two 21	AR45(H)	AU25	AR25
One + Two 22	AR45(H)	AB24	AB24
One + Two 23	AR45(H)	AB24	AR25
One + Two 24	AR45(H)	AR25	AR25

45 + 18 + 30

System No.	Indoor unit A	Indoor unit B	Indoor unit C
One + Two 25	AU45	AU18	AU30
One + Two 26	AU45	AU18	AR30
One + Two 27	AU45	AU18	AB30
One + Two 28	AU45	AB18	AU30
One + Two 29	AU45	AB18	AR30
One + Two 30	AU45	AB18	AB30
One + Two 31	AB45	AU18	AU30
One + Two 32	AB45	AU18	AR30
One + Two 33	AB45	AU18	AB30
One + Two 34	AB45	AB18	AU30
One + Two 35	AB45	AB18	AR30
One + Two 36	AB45	AB18	AB30
One + Two 37	AR45(L)	AU18	AU30
One + Two 38	AR45(L)	AU18	AR30
One + Two 39	AR45(L)	AU18	AB30
One + Two 40	AR45(L)	AB18	AU30
One + Two 41	AR45(L)	AB18	AR30
One + Two 42	AR45(L)	AB18	AB30
One + Two 43	AR45(H)	AU18	AU30
One + Two 44	AR45(H)	AU18	AR30
One + Two 45	AR45(H)	AU18	AB30
One + Two 46	AR45(H)	AB18	AU30
One + Two 47	AR45(H)	AB18	AR30
One + Two 48	AR45(H)	AB18	AB30

Two + Two

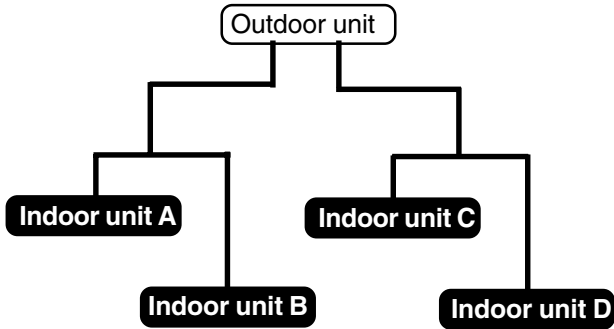

24 + 24 + 18 + 30

System No.	Indoor unit A	Indoor unit B	Indoor unit C	Indoor unit D
Two + Two 22	AU25	AU25	AU18	AU30
Two + Two 23	AU25	AU25	AU18	AR30
Two + Two 24	AU25	AU25	AU18	AB30
Two + Two 25	AU25	AU25	AB18	AU30
Two + Two 26	AU25	AU25	AB18	AR30
Two + Two 27	AU25	AU25	AB18	AB30
Two + Two 28	AU25	AB24	AU18	AU30
Two + Two 29	AU25	AB24	AU18	AR30
Two + Two 30	AU25	AB24	AU18	AB30
Two + Two 31	AU25	AB24	AB18	AU30
Two + Two 32	AU25	AB24	AB18	AR30
Two + Two 33	AU25	AR25	AB18	AB30
Two + Two 34	AU25	AR25	AU18	AU30
Two + Two 35	AU25	AR25	AU18	AR30
Two + Two 36	AU25	AR25	AU18	AB30
Two + Two 37	AU25	AR25	AB18	AU30
Two + Two 38	AU25	AR25	AB18	AR30
Two + Two 39	AU25	AR25	AB18	AB30
Two + Two 40	AB24	AB24	AU18	AU30
Two + Two 41	AB24	AB24	AU18	AR30
Two + Two 42	AB24	AB24	AU18	AB30
Two + Two 43	AB24	AB24	AB18	AU30
Two + Two 44	AB24	AB24	AB18	AR30
Two + Two 45	AB24	AB24	AB18	AB30
Two + Two 46	AB24	AR25	AU18	AU30
Two + Two 47	AB24	AR25	AU18	AR30
Two + Two 48	AB24	AR25	AU18	AB30
Two + Two 49	AB24	AR25	AB18	AU30
Two + Two 50	AB24	AR25	AB18	AR30
Two + Two 51	AB24	AR25	AB18	AB30
Two + Two 52	AR25	AR25	AU18	AU30
Two + Two 53	AR25	AR25	AU18	AR30
Two + Two 54	AR25	AR25	AU18	AB30
Two + Two 55	AR25	AR25	AB18	AU30
Two + Two 56	AR25	AR25	AB18	AR30
Two + Two 57	AR25	AR25	AB18	AB30

24 + 24 + 24 + 24

System No.	Indoor unit A	Indoor unit B	Indoor unit C	Indoor unit D
Two + Two 1	AU25	AU25	AU25	AU25
Two + Two 2	AU25	AU25	AU25	AB24
Two + Two 3	AU25	AU25	AU25	AR25
Two + Two 4	AU25	AU25	AB24	AB24
Two + Two 5	AU25	AU25	AB24	AR25
Two + Two 6	AU25	AU25	AR25	AR25
Two + Two 7	AU25	AB24	AU25	AB24
Two + Two 8	AU25	AB24	AU25	AR25
Two + Two 9	AU25	AB24	AB24	AB24
Two + Two 10	AU25	AB24	AB24	AR25
Two + Two 11	AU25	AB24	AR25	AR25
Two + Two 12	AU25	AR25	AU25	AR25
Two + Two 13	AU25	AR25	AB24	AB24
Two + Two 14	AU25	AR25	AB24	AR25
Two + Two 15	AU25	AR25	AR25	AR25
Two + Two 16	AB24	AB24	AB24	AB24
Two + Two 17	AB24	AB24	AB24	AR25
Two + Two 18	AB24	AB24	AR25	AR25
Two + Two 19	AB24	AR25	AB24	AR25
Two + Two 20	AB24	AR25	AR25	AR25
Two + Two 21	AR25	AR25	AR25	AR25

18 + 30 + 18 + 30

System No.	Indoor unit A	Indoor unit B	Indoor unit C	Indoor unit D
Two + Two 58	AU18	AU30	AU18	AU30
Two + Two 59	AU18	AU30	AU18	AR30
Two + Two 60	AU18	AU30	AU18	AB30
Two + Two 61	AU18	AU30	AB18	AU30
Two + Two 62	AU18	AU30	AB18	AR30
Two + Two 63	AU18	AU30	AB18	AB30
Two + Two 64	AU18	AR30	AU18	AR30
Two + Two 65	AU18	AR30	AU18	AB30
Two + Two 66	AU18	AR30	AB18	AU30
Two + Two 67	AU18	AR30	AB18	AR30
Two + Two 68	AU18	AR30	AB18	AB30
Two + Two 69	AU18	AB30	AU18	AB30
Two + Two 70	AU30	AB30	AB18	AU30
Two + Two 71	AU30	AB30	AB18	AR30
Two + Two 72	AU30	AB30	AB18	AB30
Two + Two 73	AB18	AU30	AB18	AU30
Two + Two 74	AB18	AU30	AB18	AR30
Two + Two 75	AB18	AU30	AB18	AB30
Two + Two 76	AB18	AR30	AB18	AR30
Two + Two 77	AB18	AR30	AB18	AB30
Two + Two 78	AB18	AB30	AB18	AB30

(3) Centralized control is enabled by wire remote controller with weekly timer

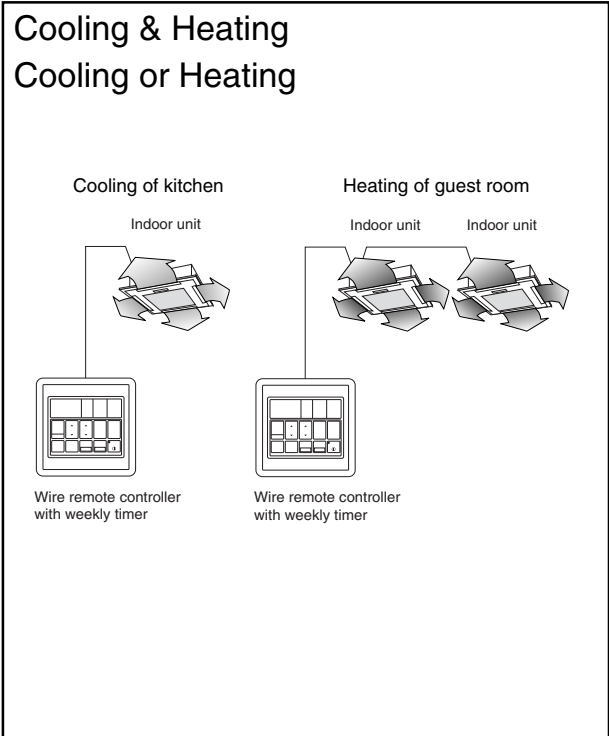

Example: Restaurant

Weekly schedule

Heating of guest room

Sun	Mon	Tue	Wed	Thu	Fri	Sat
On	Off	On	On	On	On	On

Cooling of kitchen

Sun	Mon	Tue	Wed	Thu	Fri	Sat
On	Off	On	On	On	On	On

Operation: On time Guest room Kitchen
 On time 10:00 ~ 14:00 8:00 ~ 14:00
 On time 17:00 ~ 21:00 16:00 ~ 23:00

- (4) Space saving
- (5) Easy installation
- (6) Cooling & heating at low outdoor temperatures

NOTE: Items (4), (5) and (6) on this page are common to items (4), (5) and (6) on page 11.

2. FEATURES

2 - 1. OUTDOOR UNIT

- MODELS : AO90EP3L
AO90TP3L
AO90EPMA
AO90TPMA



■ FEATURES

● Capacity

Simultaneous operation multi type system	86,000 ~ 95,000BTU
Individual operation multi type system	90,000 ~ 96,000BTU

● New compact

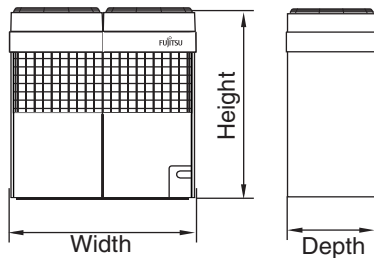

Dimensions

Height **1,380**
Width **1,300**
Depth **650**

(Unit : mm)

● Compact construction

Layout of evaporator and fan allows us to reduce the height.

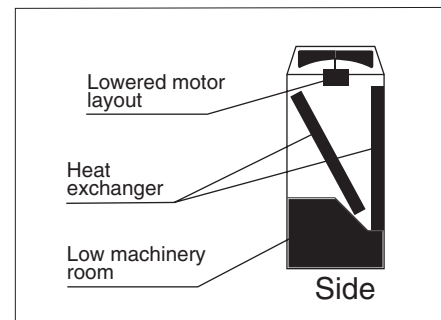

● Outdoor unit goes into elevator

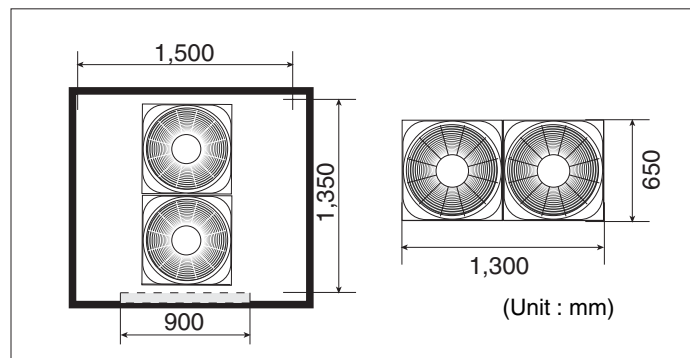

● Space saving

Space saved by setting side by side without space in between.

Setting size

5.32 (Unit : m²)

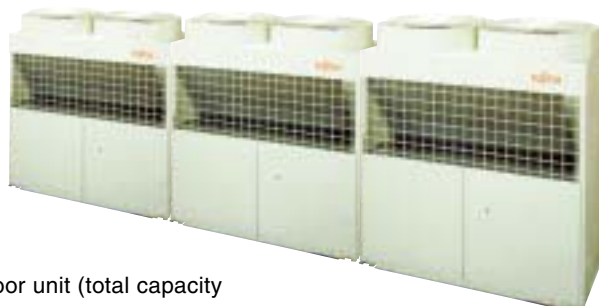

Only a small area is needed for outdoor unit (total capacity 30HP, height of surrounding wall 1.5m)

● **Low noise level**

Large 590mm diameter fan provides top class low noise level.

Low outdoor unit (10HP)
noise level

57 (unit : dB)

● **Easy maintenance**

Indication of operating status on PCB.

Indicating the operating status and details of failures on PCB in the outdoor unit allows better service and quick and easy maintenance.

Easy to replace compressors

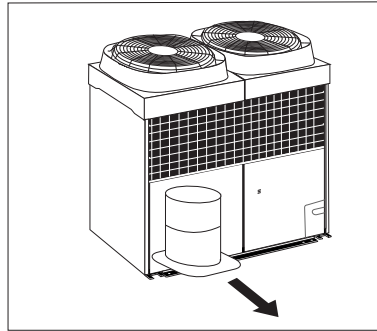

● **Easy installation**

Five-direction pipe allows a variety of installation, configurations

Easy installation and pipe direction setting

Five-direction pipe

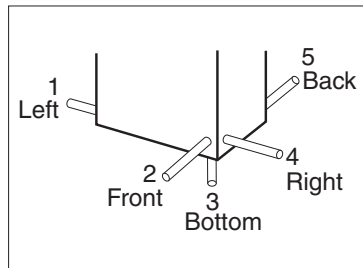

Outdoor unit can be lifted by a crane set on the roof of the building

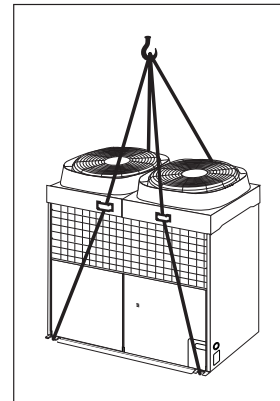

■ **OTHERS**

- Power requirement 3-phase 4-wire
- Alternate refrigerant R407C
- Maximum piping length of 50m (100m)
- Maximum height differential of 30m (50m)

	Simultaneous / Individual Operation
Maximum Length	50m (100m)
Height Difference	30m (50m)

- Chargeless design 30m
- Cooling operation possible at low outdoor-temperature 0°C
- Heating operation possible at low outdoor-temperature -10°C

2 - 2. INDOOR UNIT

(1) UNIVERSAL FLOOR / CEILING TYPE

■ MODELS : AB18, AB24



■ FEATURES

● Compact design

Symmetrical thin and compact design

Flat and round form

● Flexible installation

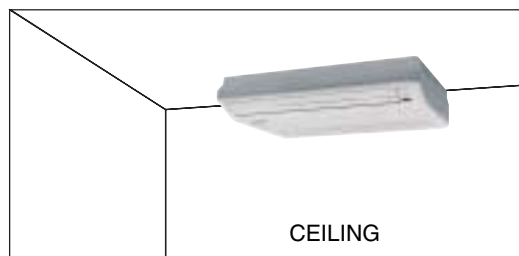
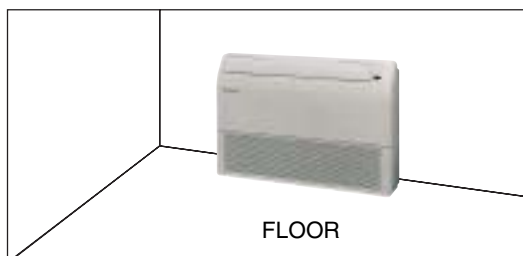

● Double auto swing

Combination of up/down and right/left air direction swing allows three-dimensional air direction control.

Since up/down air direction flaps operate automatically, according to the operating mode of the unit, it is possible to set the air direction based on the operating mode.

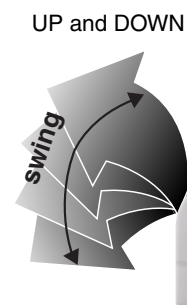
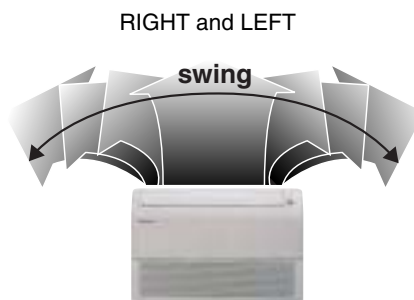

● Super vane

The double-flap "Super Vane" with newly developed special configuration boosts the air flow, sending cool air quickly to every corner of the room.

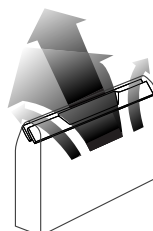

New model

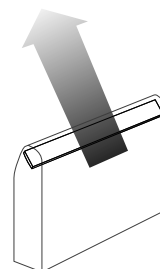

Old model

● Others

- Auto-Changeover (Heat Pump Model)
- Auto Restart
- Detachable and Washable Open Panel
- Auto Shut Flaps

(2) LARGE CEILING TYPE

- MODELS : AB30, AB36
AB45



■ FEATURES

● Installation

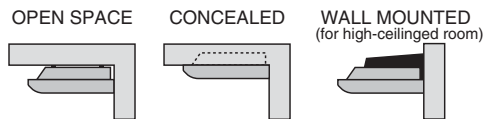

● Fresh-air intake

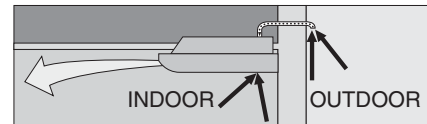

● Drain lift-up mechanism

Optional drain lift-up mechanism allows more flexible installation.

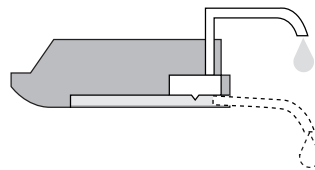

● Double auto swing

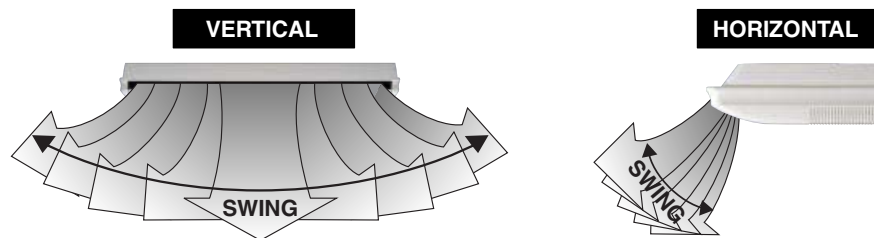

■ Others

- Auto-Changeover (Heat Pump Model)
- Auto Restart
- Detachable and Washable Open Panel
- Auto Shut Flaps

(3) DUCT TYPE

- MODELS : AR25, AR30
AR36, AR45

Installed behind the ceiling (or with a double ceiling for existing rooms) this design offers space savings and low noise. One outdoor unit can condition the air of multiple rooms. With a beautiful finish, the outlet grille does not stick out into the room.



■ FEATURES

- Ultra thin models for very low ceilings

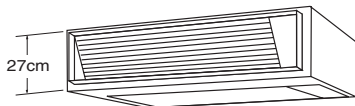

36,000/45,000BTU/h Type

- Piping can be laid in almost any direction
- Fresh air can be taken in from two directions

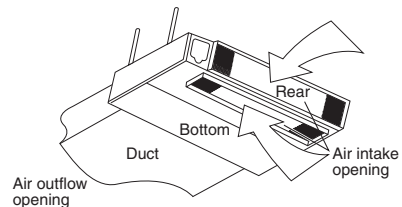
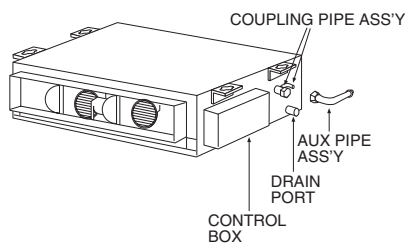

- Sample installation / Installation style

Sample installation

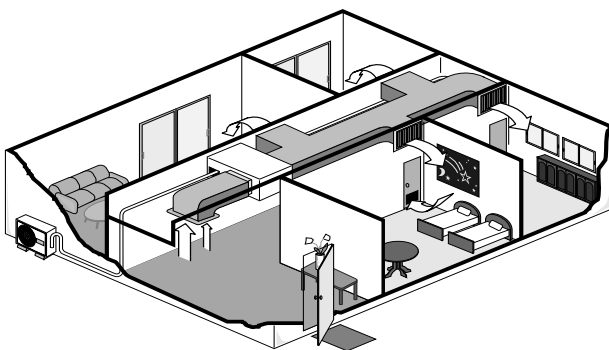

- Auto-Changeover
- Auto Restart

Installation styles

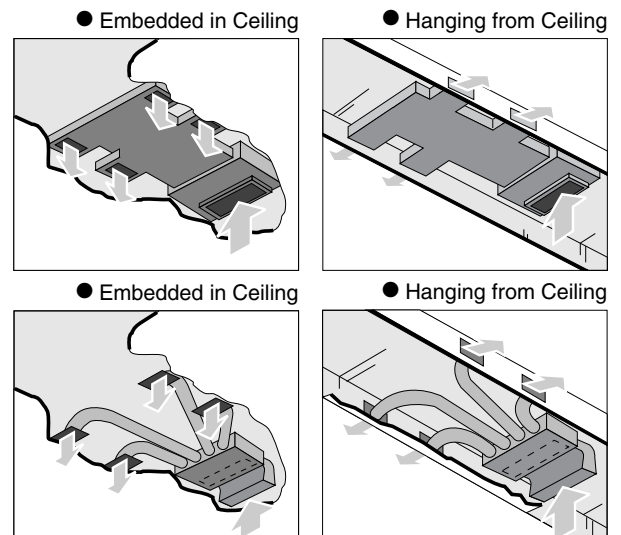

(4) HIGH STATIC PRESSURE DUCT TYPE

■ MODELS : AR36H, AR45H

Installed behind the ceiling this design offers space savings and low noise. One outdoor unit can condition the air of multiple rooms. With a beautiful finish, the outlet does not stick out into the room.



■ FEATURES

● High static pressure

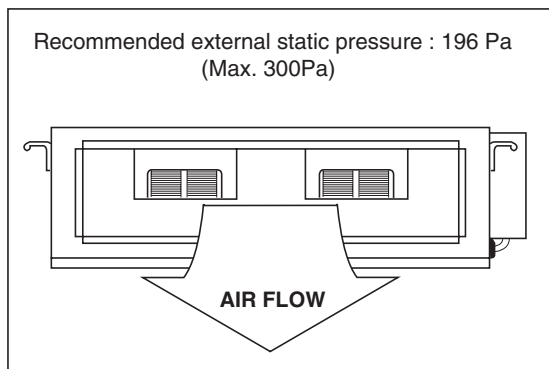

● Easy maintenance

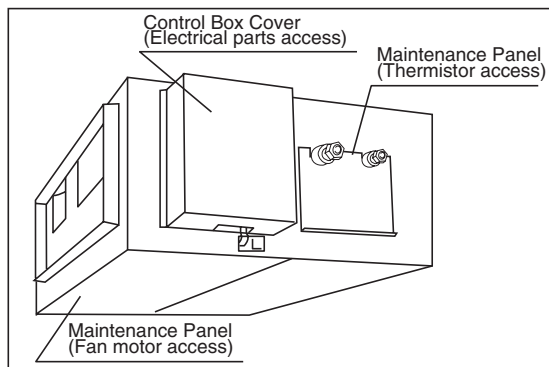

- Auto-Changeover
- Auto Restart

(5) COMPACT CASSETTE TYPE

■MODEL : AU18



■ FEATURES

● Compact

Fit to ceiling tiles (600mm x 600mm)

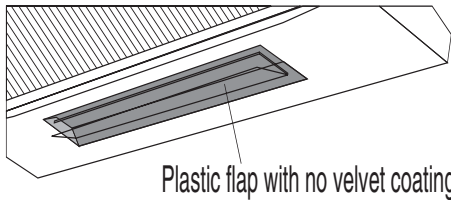

Dimensions (12,000 to 14,000 and 18,000 BTU)

● Auto air flow direction & auto swing

2-WAY

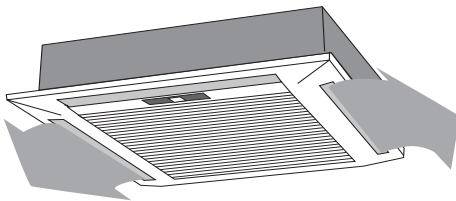

● Light weight & easy installation

Body : 18kg

Panel : 2.2kg

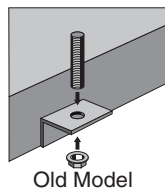
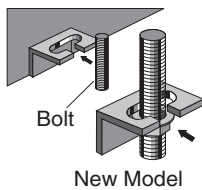
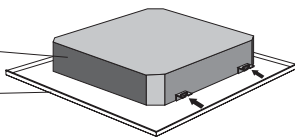

● Flat & simple design

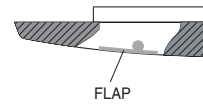

● Adjustable grill

Adjustment to ceiling design

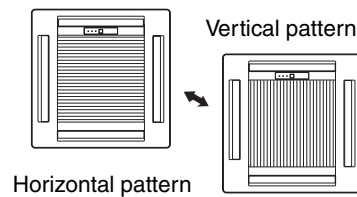

● 4-way air flow system

You can select 2-way, 3-way or 4-way air flow to suit your needs.



● Easy maintenance

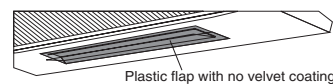
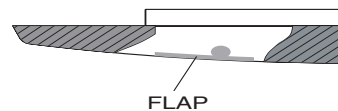

(6) NEW CASSETTE TYPE

- MODELS : AU25, AU30, AU36, AU45



■ FEATURES

● Flexible installation

Small and compact body allows space saving installation

New mechanism allows the cassette body to move 35mm downward and contributes to keeping the ceiling surface clean

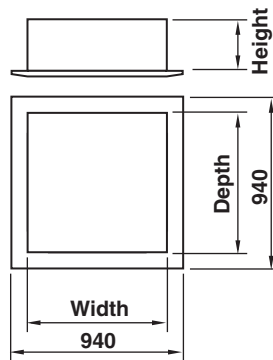

Setting space

Height	250 or 285
Width	840
Depth	840

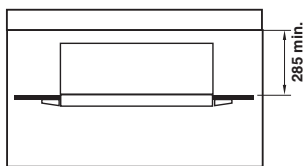

Standard setting

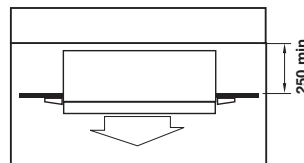

Slender setting

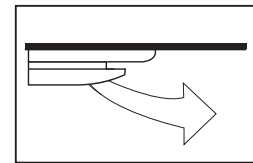

● Improvement of noise level and air distribution

Comparison of noise level (dB)

Noise level is drastically reduced by molded fan motor, bigger caliber turbo-fan and larger air flow passage.

Improvement of fan blade

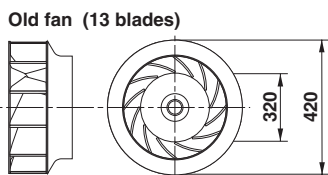

(Unit : mm)

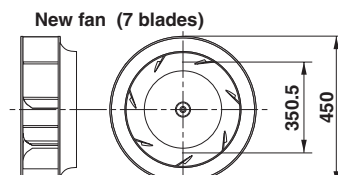

(Unit : mm)

Wide air flow

Larger air flap distributes the outlet air flow a longer distance in the horizontal direction

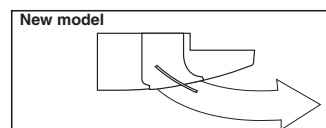
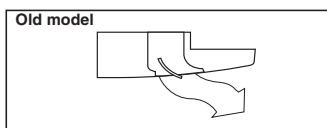

● New grill design

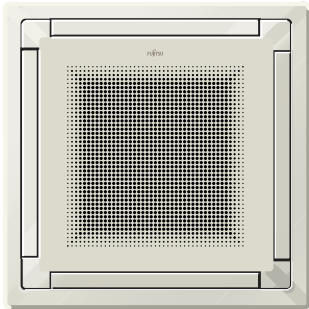

Symmetrical design

New 'Punch hole' grill harmonizes with any interior design, even when several units are installed in one room

● Easy cleaning

Thin grill, auto-close flaps without velvet coating and flat surface allow easy cleaning

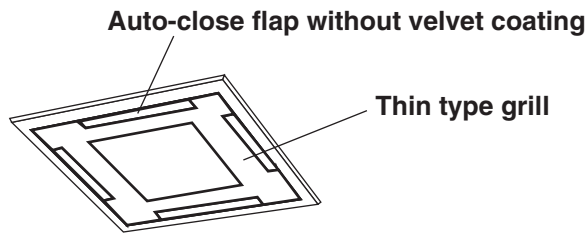

● Easy installation

Since the cassette body can be installed using a grill frame, it is easy to fit in the ceiling surface.

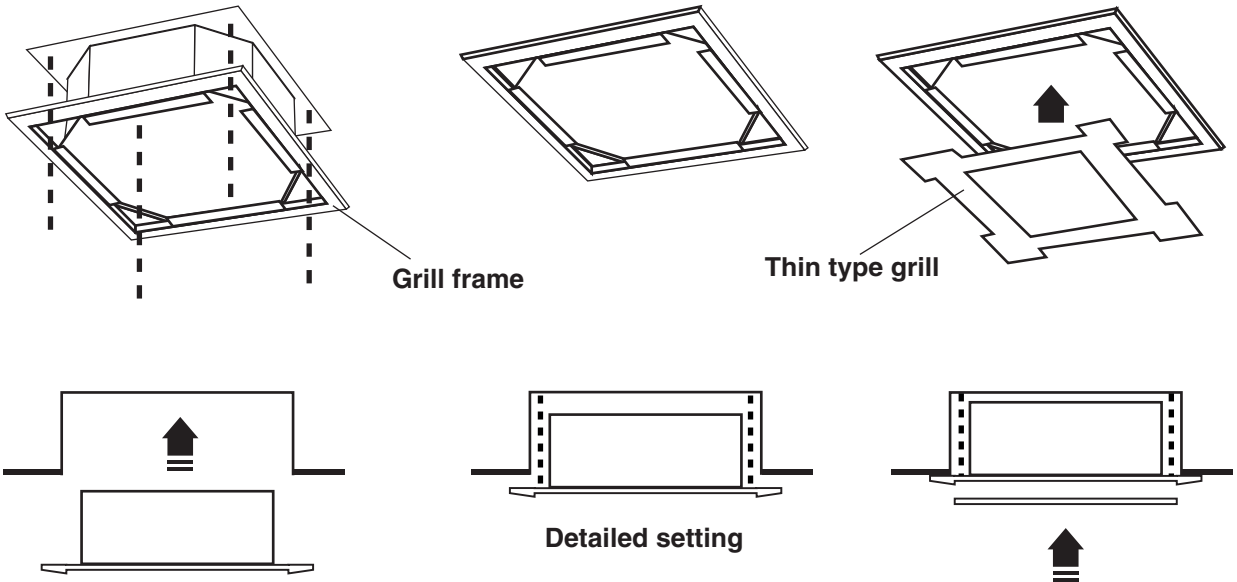

2 - 3. REMOTE CONTROLLER

WIRE REMOTE CONTROLLER WITH WEEKLY TIMER

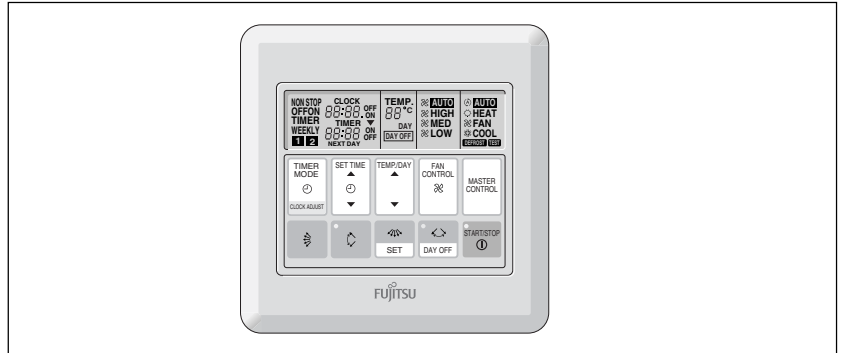

■ FEATURES

- Three kinds of timer setup (OFF/ON/WEEKLY) are possible.
- Function of weekly timer

Setting of different on-off time by day.

Setting of set on-off time twice a day.

Setting of time in 5 minute steps.

Timer operation of a reserved day can be temporarily cancelled by pushing the DAY OFF button.

Time setting can be left until the next day.

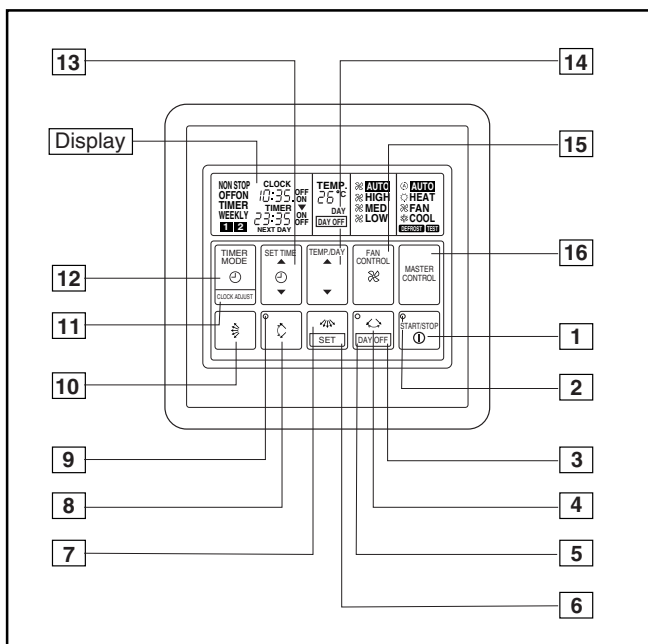

- 1** START/STOP Button
Pressed to start and stop operation.
- 2** OPERATION Lamp
Lights during operation and when the timer is on.
- 3** DAY OFF Button
Temporary cancellation of one day timer.
- 4** HORIZONTAL SWING Button
- 5** HORIZONTAL SWING Lamp
- 6** SET Button
Sets the date, hour, minute and on-off time.
- 7** HORIZONTAL AIR FLOW DIRECTION Button
- 8** VERTICAL SWING Button
- 9** VERTICAL SWING Lamp
- 10** VERTICAL AIR FLOW DIRECTION Button
- 11** CLOCK ADJUST Button
- 12** TIMER MODE Button
Changes the timer mode (NON STOP, OFF TIMER, ON TIMER, WEEKLY TIMER).
- 13** SET TIME Button
Sets the current time and on-off time.
- 14** TEMP./DAY Button
Sets the indoor temperature / days.
- 15** FAN CONTROL Button
Selects the fan speed (AUTO, HIGH, MED, LOW).
- 16** MASTER CONTROL Button
Selects the operating mode (AUTO, HEAT, FAN, COOL).
- 17** Clock Display
- 18** Set Temperature / Day Display (TEMP./DAY)
- 19** Operation Mode Display
- 20** Timer Mode Display
- 21** Fan Speed Display
- 22** DEFROST Display
- 23** TEST Display

Display panel

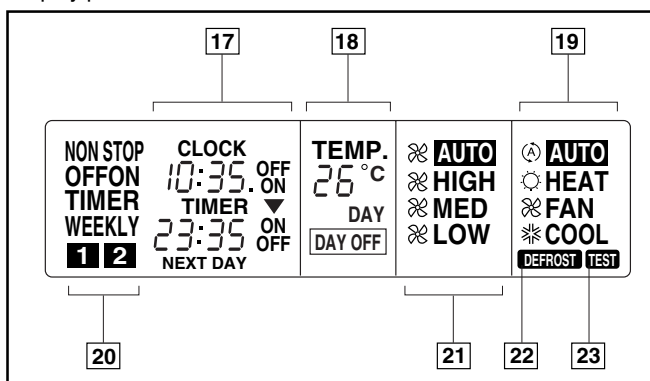

Setting the WEEKLY TIMER

①

TIMER MODE

Push the **TIMER MODE** button and select **WEEKLY TIMER**.

②

TEMP/DAY

Push the **TEMP/DAY** button to set the day of the week.

Pushing this button causes the number to change in 1-2-3-4-5-6-7 order (instead of week day indication).

1	2	3	4	5	6	7
MON	TUE	WED	THU	FRI	SAT	SUN

③

SET

Push the **SET** button for three seconds.

④

SET TIME

Push the **SET TIME** button to set ON/OFF time.

⑤

SET

End setting by pressing the **SET** button.

Repeat steps ② to ⑤ (except for ③) until you finish setting for the whole week.

⑥

SET

After having set everything for the indicated day, push the **SET** button for three seconds.

⑦

START / STOP

Start operation the WEEKLY MODE by pressing the **START/STOP** button.

3.DATA

3 - 1. DIMENSIONS

■ OUTDOOR UNIT

(Unit : mm)

- MODELS : AO90EP3L
AO90TP3L
AO90EPMA
AO90TPMA

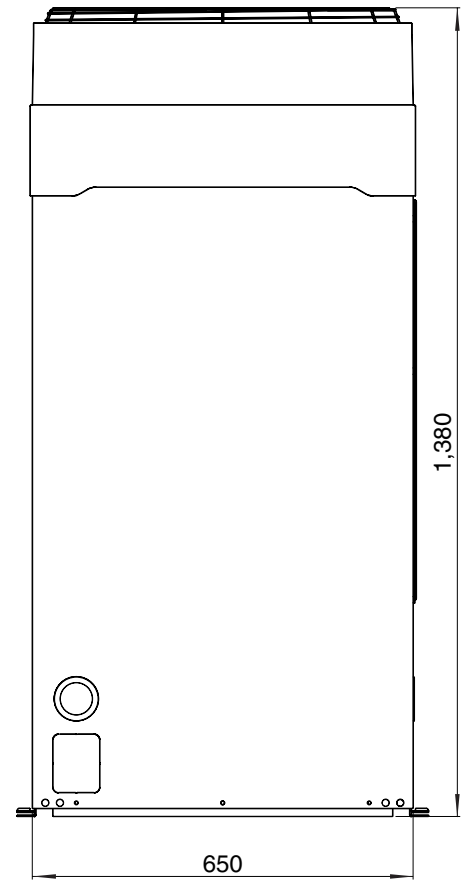
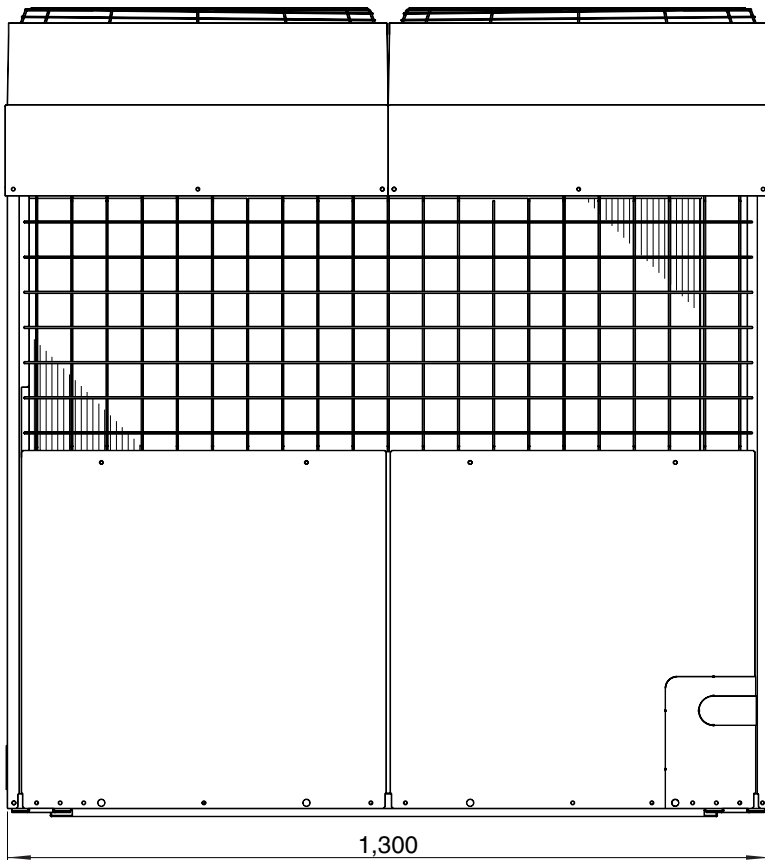
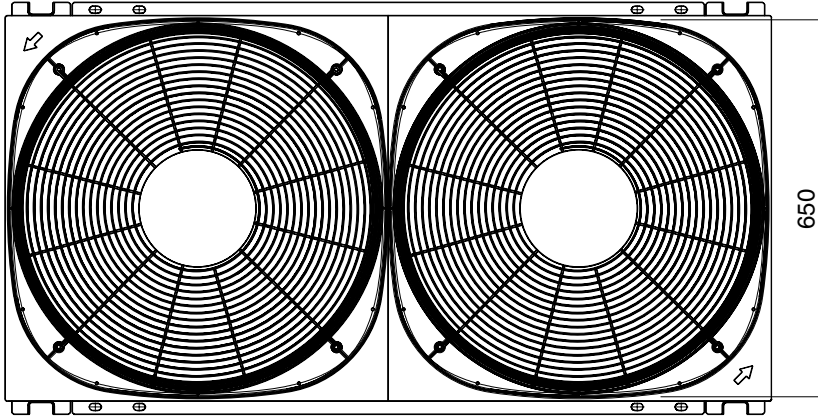

■ INDOOR UNITS (UNIVERSAL FLOOR / CEILING TYPE)

(Unit : mm)

- MODELS : AB18, AB24

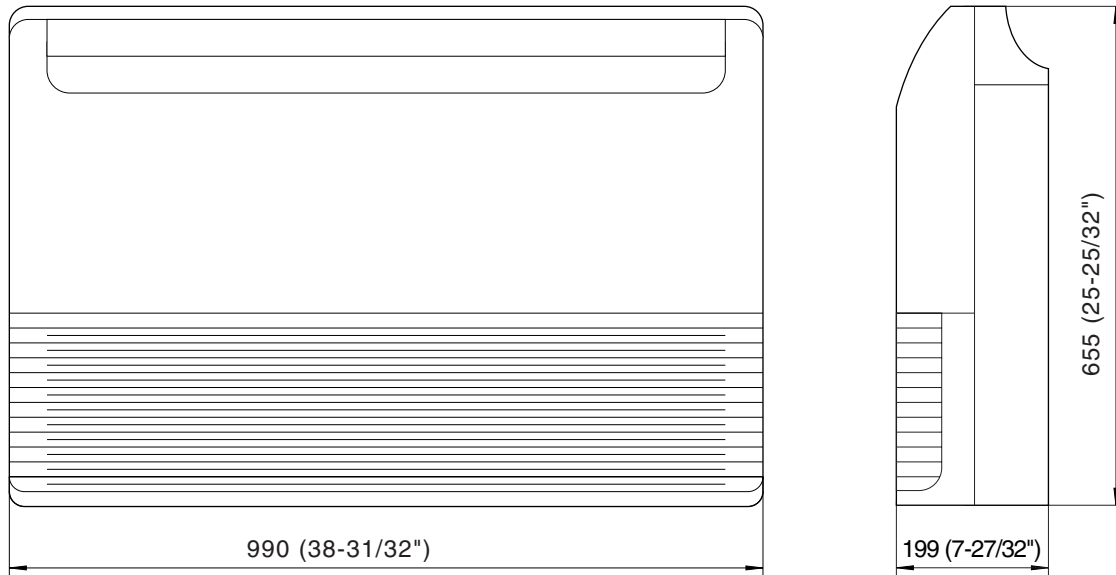

[Rear View]

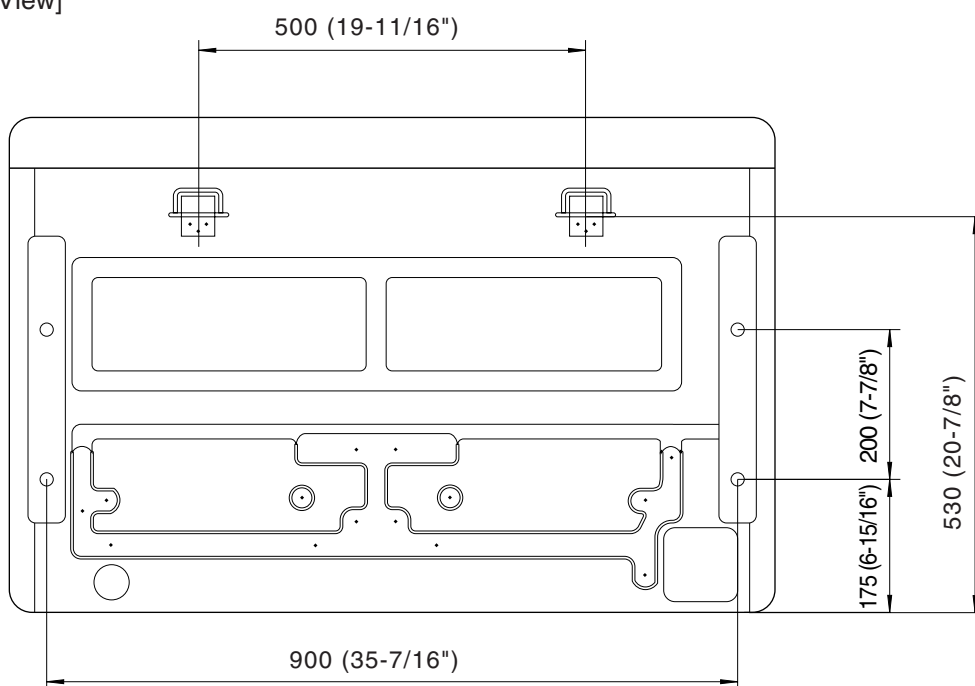

LARGE CEILING TYPE

(Unit : mm)

- MODELS : AB30, AB36, AB45

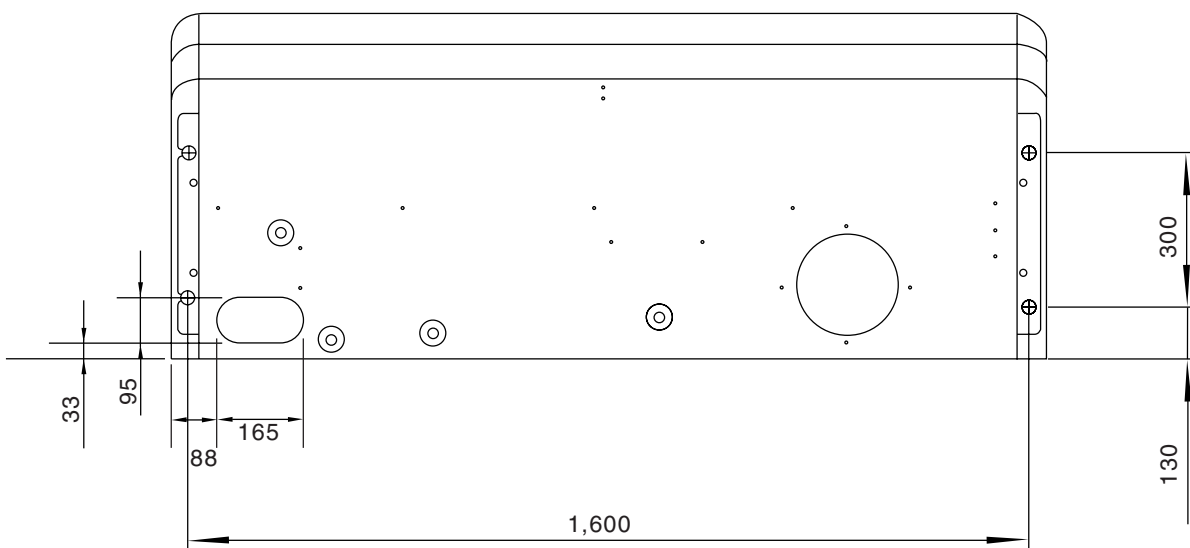
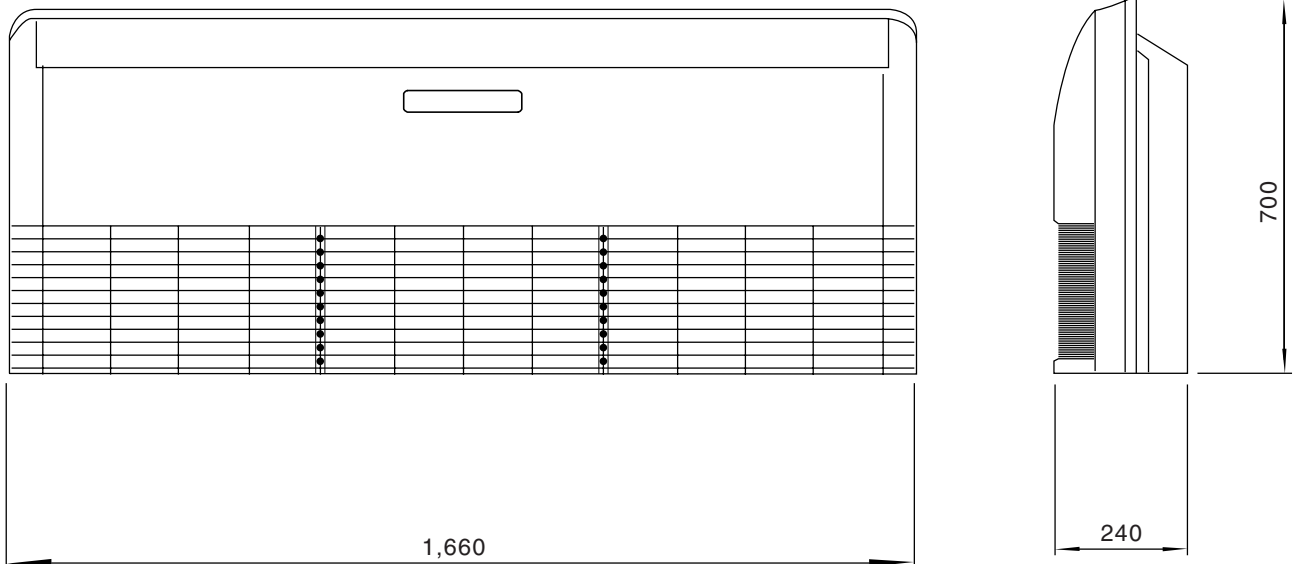

LOW STATIC PRESSURE DUCT TYPE

(Unit : mm)

- MODELS: AR25, AR30, AR36, AR45

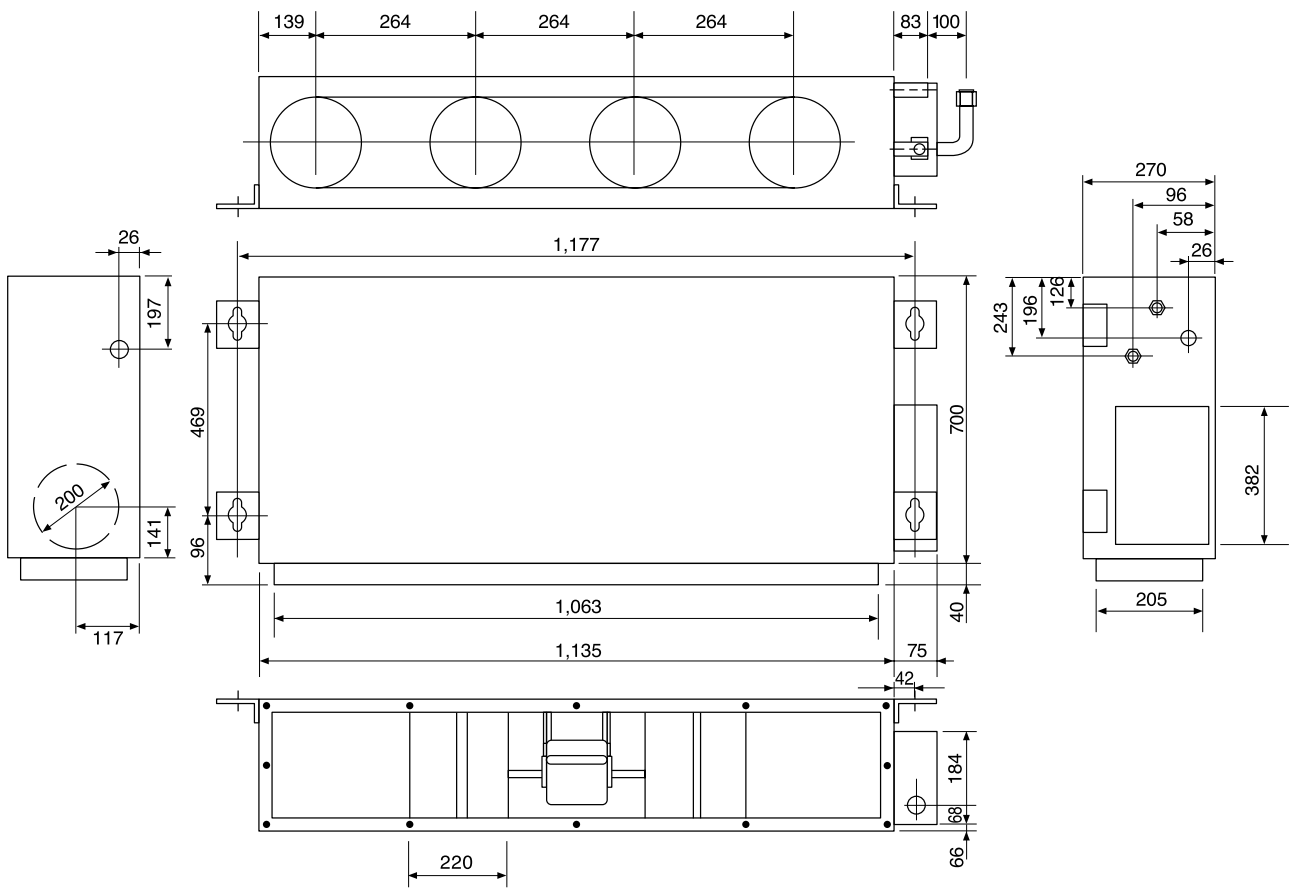
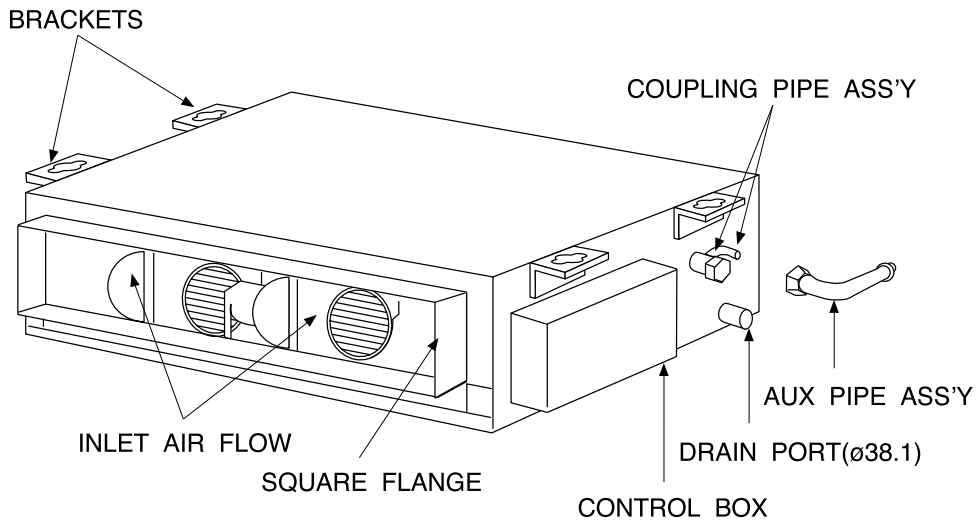

HIGH STATIC PRESSURE DUCT TYPE

(Unit : mm)

- MODELS : AR36H, AR45H

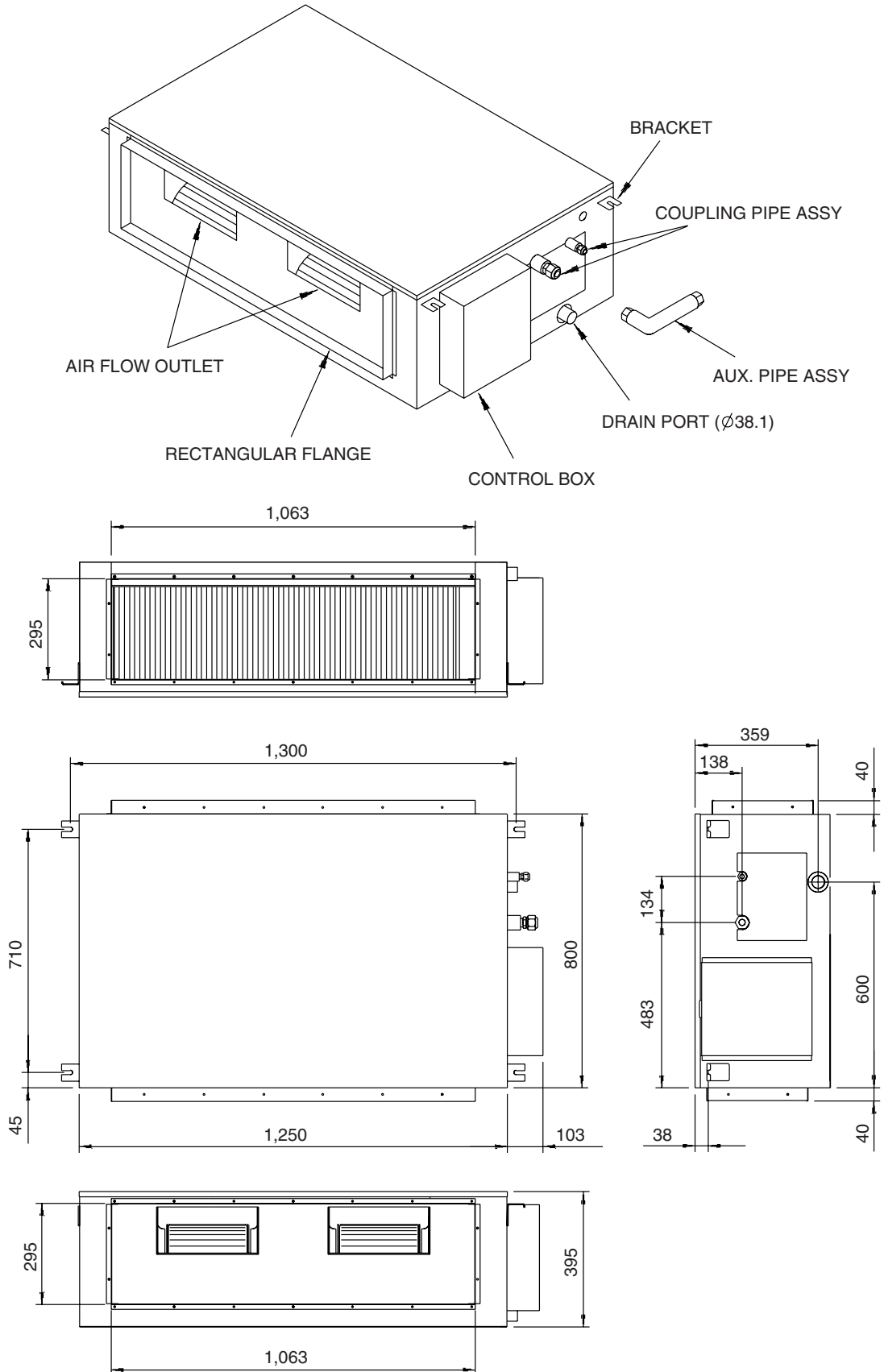

COMPACT CASSETTE TYPE

(Unit : mm)

- MODELS : AU18

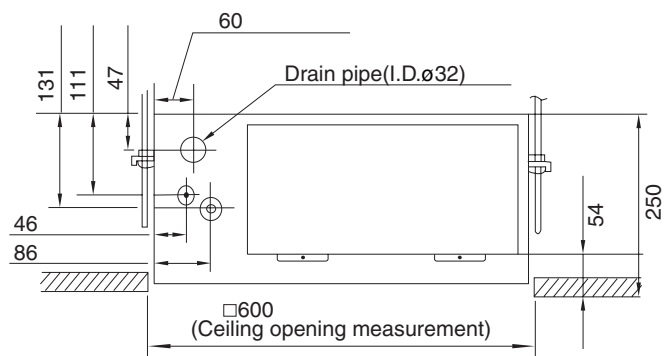
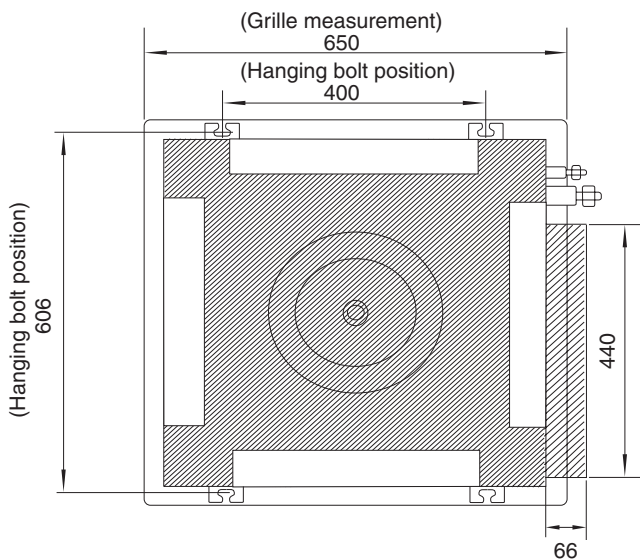
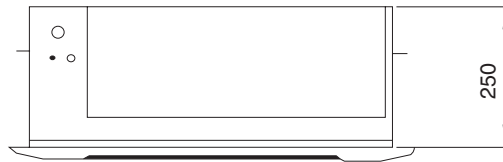
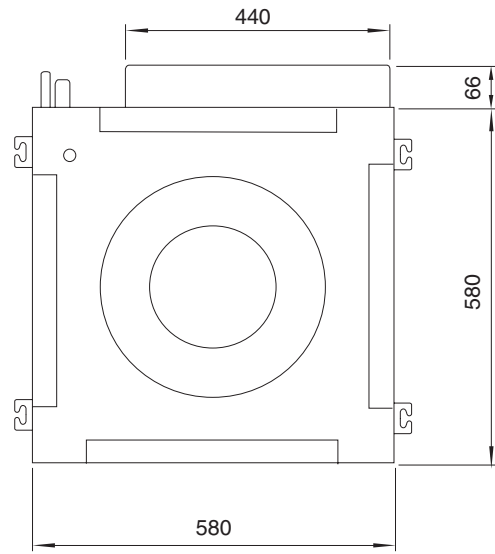
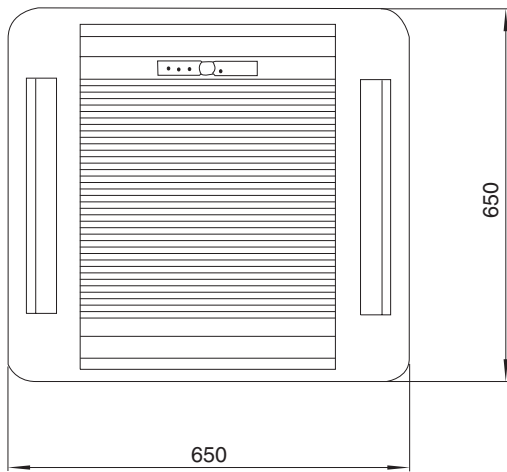
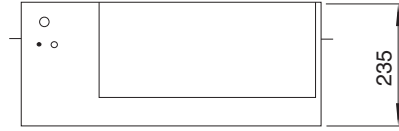

CASSETTE TYPE

(Unit : mm)

- MODELS : AU25, AU30, AU36, AU45

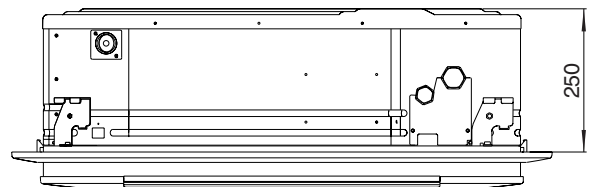
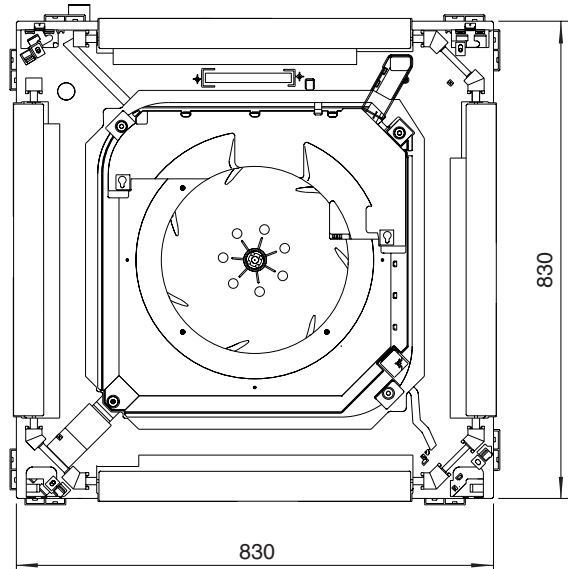
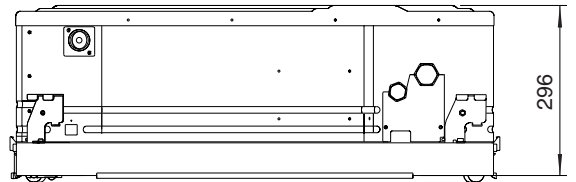
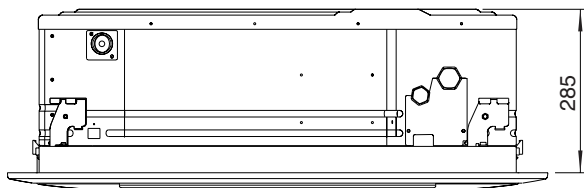
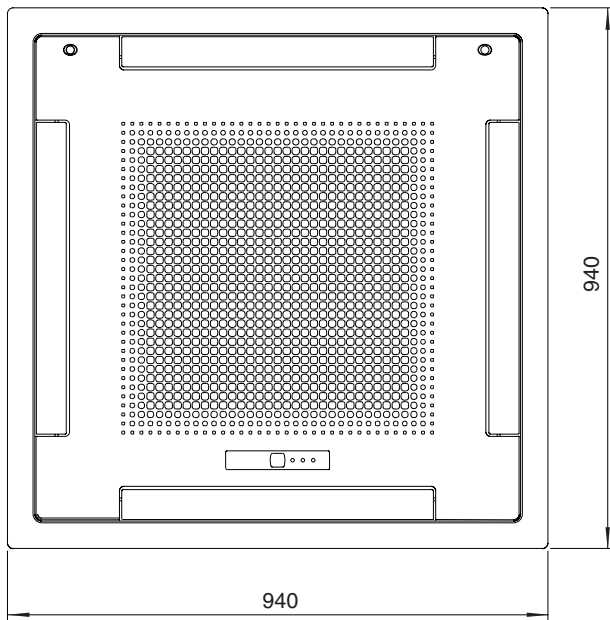

3 - 2. SPECIFICATIONS

■ OUTDOOR UNIT

Model				AO 90EP 3L	AO 90TP 3L	
Power Requirement			ϕ , Hz	ϕ 3 W4, 50Hz		
			V	380 – 415		
Total Input	Cooling	kW	9.4	9.4		
	Heating	kW	—	10.0		
Total Current	Cooling	A	16.2	16.2		
	Heating	A	—	17.0		
Starting Current		A	63	63		
EER	Cooling	W/W	2.7	2.7		
	Heating	W/W	—	2.9		
Fan Speed	High	r.p.m.	730			
	Low	r.p.m.	360			
Air Circulation	High	m ³ /h	9,500			
Heat Exchanger			Plate Fin Coil			
Fan Type x Q'ty			Propeller x 2			
Fan Motor Output		W	150 x 2			
Compressor	Motor Output	W	6.4			
	Protection		Internal Protector(OCR), High Pressure Relief Valve			
Dimensions (H x W x D)	Net	mm	1,380 x 1,300 x 650			
	Gross	mm	1,535 x 1,400 x 770			
Weight	Net	kg	243	245		
	Gross	kg	280	282		
Noise Level (Sound Pressure)		dB(A)	57	57		
Refrigeration cycle	Discharge Pressure		kg/cm ²	20		
	Suction Pressure		kg/cm ²	5.0		
	Discharge Temp.		°C	72		
	Suction Temp.		°C	7		
	Discharge Air Temp.		°C	44		
Condition	Indoor Air Temp.	Cooling	DB/WB	27°C / 19°C		
		Heating	DB/WB	20°C / (15)°C		
	Outdoor Air Temp.	Cooling	DB/WB	35°C / 24°C		
		Heating	DB/WB	7°C / 6°C		
Refrigerant	Type		R407C			
	Charge		kg	6.0	6.0	
Pipe	Size	Liquid	mm(inch)	12.7 (1/2")		
		Gas	mm(inch)	28.6 (1-1/8")		
	Connection Method	Liquid	mm	Flare		
		Gas	mm	Flange		
	Max Length		m	50		
	Max Height		m	30		
	Max Chargeless Length		m	30		
Operation	Cooling/Heating		°C	0 ~ 52 / -10 ~ 21		

Model			AO 90EP MA	AO 90TP MA	
Power Requirement		ϕ , Hz	ϕ 3 W4, 50Hz		
		V	380 – 415		
Total Input	Cooling	kW	9.4	9.4	
	Heating	kW	—	10.0	
Total Current	Cooling	A	16.2	16.2	
	Heating	A	—	17.0	
Starting Current		A	63	63	
EER	Cooling	W/W	2.7	2.7	
	Heating	W/W	—	2.9	
Fan Speed	High	r.p.m.	730		
	Low	r.p.m.	360		
Air Circulation	High	m ³ /h	9,500		
Heat Exchanger			Plate Fin Coil		
Fan Type x Q'ty			Propeller x 2		
Fan Motor Output		W	150 x 2		
Compressor	Motor Output	W	3.2 x 2		
	Protection		Internal Protector(OCR), High Pressure Relief Valve		
Dimensions (H x W x D)	Net	mm	1,380 x 1,300 x 650		
	Gross	mm	1,535 x 1,400 x 770		
Weight	Net	kg	243	245	
	Gross	kg	280	282	
Noise Level (Sound Pressure)		dB(A)	57	57	
Refrigerant cycle	Discharge Pressure		kg/cm ²	19.4	
	Suction Pressure		kg/cm ²	4.5	
	Discharge Temp.		°C	83	
	Suction Temp.		°C	7	
	Discharge Air Temp.		°C	44	
Condition	Indoor Air Temp.	Cooling	DB/WB	27°C / 19°C	
		Heating	DB/WB	20°C / (15)°C	
	Outdoor Air Temp.	Cooling	DB/WB	35°C / 24°C	
		Heating	DB/WB	7°C / 6°C	
Refrigerant	Type		R407C		
	Charge		kg	3.1 x 2 3.1 x 2	
Pipe	Size	Liquid	mm(inch)	9.53 (3/8")	
		Gas	mm(inch)	19.05 (6/8")	
	Connection Method	Liquid	mm	Flare	
		Gas	mm	Flare	
	Max Length		m	50	
	Max Height		m	30	
	Max Chargeless Length		m	30	
Operation	Cooling/Heating		°C	0 ~ 52 / -10 ~ 21	

■ INDOOR UNIT

Model			AB18	AB24	AB30	AB36	AB45
Power Requirement		V	220 – 240				
Capacity	Cooling	kW	5.20 – 5.30	6.50 – 6.60	8.6 – 8.8	10.3 – 10.5	12.4 – 12.7
		BTU/h	17,800 ~ 18,100	22,200 ~ 22,500	29,400 ~ 30,000	35,200 ~ 36,000	42,500 ~ 43,500
	Heating	kW	5.50 – 5.60	7.60 – 7.70	8.8 – 9.1	10.5 – 10.7	13.4 – 13.7
		BTU/h	18,800 ~ 19,100	25,900 ~ 26,300	30,000 ~ 31,000	36,000 ~ 36,500	46,000 ~ 47,000
Moisture Removal		ℓ/hr	2.2	3.4	3.5	4.0	5.0
Air Circulation	High	m ³ /h	770	900	1,270	1,660	1,850
	Med		680	780	1,120	1,500	1,660
	Low		560	660	860	1,270	1,430
Fan Speed	High	r.p.m.	1,030	1,180	850	1,000	1,100
	Med		890	1,040	750	900	1,000
	Low		770	900	600	750	850
Fan Motor Output		W	30	40	60	70	80
Noise (Sound Pressure)	High	dB(A)	47	49	41	47	50
	Med		42.5	45	37	44	48
	Low		38	41	32	39	44
Fan Type x Q'ty			Sirocco x 2		Sirocco x 4		
Heat Exchanger			Plate fin coil				
Operation Control			LCD remote control				
Dimensions (H x W x D)	Net	mm	199 x 990 x 655			240 x 1,660 x 700	
	Gross	mm	320 x 1,150 x 790			318 x 1,800 x 790	
Weight	Net	kg	28	30	48	48	48
	Gross	kg	37	39	61	61	61
Pipe Size	Liquid	mm	9.53				
	Gas	mm	15.88			19.05	
Pipe Connection Method			Flare				
Drain Pipe Size		mm	φ 26		φ 24		
Operation	Cool/Heat	°C	18 ~ 32 / 16 ~ 32				

Model			AU18	AU25	AU30	AU36	AU45
Power Requirement		V	220 – 240				
Capacity	Cooling	kW	4.85 – 5.00	6.95 – 7.05	8.60 – 8.80	10.3 – 10.5	12.4 – 12.7
		BTU/h	19,000 ~ 19,900	23,700 ~ 24,100	29,400 ~ 30,000	35,200 ~ 35,800	42,300 ~ 43,400
	Heating	kW	5.30 – 5.45	7.60 – 7.85	8.80 – 9.10	10.5 – 10.7	13.4 – 13.7
		BTU/h	21,000 ~ 21,600	25,900 ~ 26,800	30,000 ~ 31,100	35,800 ~ 36,500	45,800 ~ 46,800
Moisture Removal		ℓ/hr	2.1	2.5	3.0	4.0	5.0
Air Circulation	High	m ³ /h	650	1,170	1,270	1,500	1,620
	Med		550	970	1,070	1,270	1,420
	Low		490	770	880	1,040	1,190
Fan Speed	High	r.p.m.	820	460	500	580	620
	Med		740	390	430	505	550
	Low		620	320	360	420	490
Fan Motor Output		W	30	60	70	80	90
Noise (Sound Pressure)	High	dB(A)	43	43	45	47	49
	Med		40	38	41	43	45
	Low		36	34	36	38	41
Fan Type x Q'ty			Turbo				
Heat Exchanger			Plate fin coil				
Operation Control			LCD remote control				
Dimensions (H x W x D)	Net	mm	235x580x580+70	296 x 830 x 830			
	Gross	mm	280x710x750	360 x 1,060 x 1,060			
Weight	Net	kg	18	38	38	40	40
	Gross	kg	23	45	45	47	47
Pipe Size	Liquid	mm	φ 6.35	9.53			
	Gas	mm	φ 12.7	15.88		19.05	
Pipe Connection Method			Flare				
Drain Pipe Size		mm	φ 32				
Operation	Cool/Heat	°C	18 ~ 32 / 16 ~ 32				

Model			AR25	AR30	AR36	AR45
Power Requirement		V	220 – 240			
Capacity	Cooling	kW	6.95 – 7.05	8.6 – 8.8	10.3 – 10.5	12.4 – 12.7
		BTU/h	23,700 ~ 24,100	29,400 ~ 30,000	35,200 ~ 36,000	42,500 ~ 43,500
	Heating	kW	7.60 – 7.85	8.8 – 9.1	10.5 – 10.7	13.4 – 13.7
		BTU/h	25,900 ~ 26,800	30,000 ~ 31,000	36,000 ~ 36,500	46,000 ~ 47,500
Moisture Removal		ℓ/hr	2.5	3.0	5.0	6.0
Air Circulation	High	m ³ /h	1,600	1,800	2,000	2,200
	Med		1,450	1,600	1,800	2,000
	Low		1,280	1,400	1,600	1,800
Fan Speed	High	r.p.m.	890	1,150	1,250	1,340
	Med		820	1,050	1,150	1,270
	Low		745	950	1,050	1,170
Fan Motor Output		W	70	275		
Noise (Sound Pressure)	High	dB(A)	44	45	47	49
	Med		42	43	45	47
	Low		40	41	43	45
Fan Type x Q'ty		Sirocco x 2				
Heat Exchanger		Plate fin coil				
Operation Control		LCD remote control				
Dimensions (H x W x D)	Net	mm	270 x 1,210 x 700			
	Gross	mm	330 x 1,300 x 790			
Weight	Net	kg	43	43	45	45
	Gross	kg	58	58	60	60
Pipe Size	Liquid	mm	9.53			
	Gas	mm	15.88		19.05	
Pipe Connection Method		Flare				
Drain Pipe Size		mm	ϕ 38.1			
Operation	Cool/Heat	°C	18 ~ 32 / 16 ~ 32			

Model			AR36H	AR45H
Power Requirement		V	220 – 240	
Capacity	Cooling	kW	10.3 – 10.5	12.4 – 12.7
		BTU/h	35,200 ~ 36,000	42,500 ~ 43,500
	Heating	kW	10.5 – 10.7	13.4 – 13.7
		BTU/h	36,000 ~ 36,500	46,000 ~ 47,000
Moisture Removal		ℓ/hr	5.0	6.0
Air Circulation	High	m ³ /h	2,000	2,200
	Med		1,700	1,900
	Low		1,400	1,600
Fan Speed	High	r.p.m.	760	890
	Med		690	820
	Low		630	760
Fan Motor Output		W	350	
Noise (Sound Pressure)	High	dB(A)	47	48
	Med		45	46
	Low		43	44
Fan Type x Q'ty		Sirocco x 2		
Heat Exchanger		Plate fin coil		
Operation Control		LCD remote control		
Dimensions (H x W x D)	Net	mm	400 x 1,250 x 800	
	Gross	mm	495 x 1,410 x 890	
Weight	Net	kg	75	75
	Gross	kg	90	90
Pipe Size	Liquid	mm	9.53	
	Gas	mm	19.05	
Pipe Connection Method		Flare		
Drain Pipe Size		mm	ϕ 38.5	
Operation	Cool/Heat	°C	18 ~ 32 / 16 ~ 32	

3 - 3. PERFORMANCE CURVES

INDOOR UNIT

COOLING

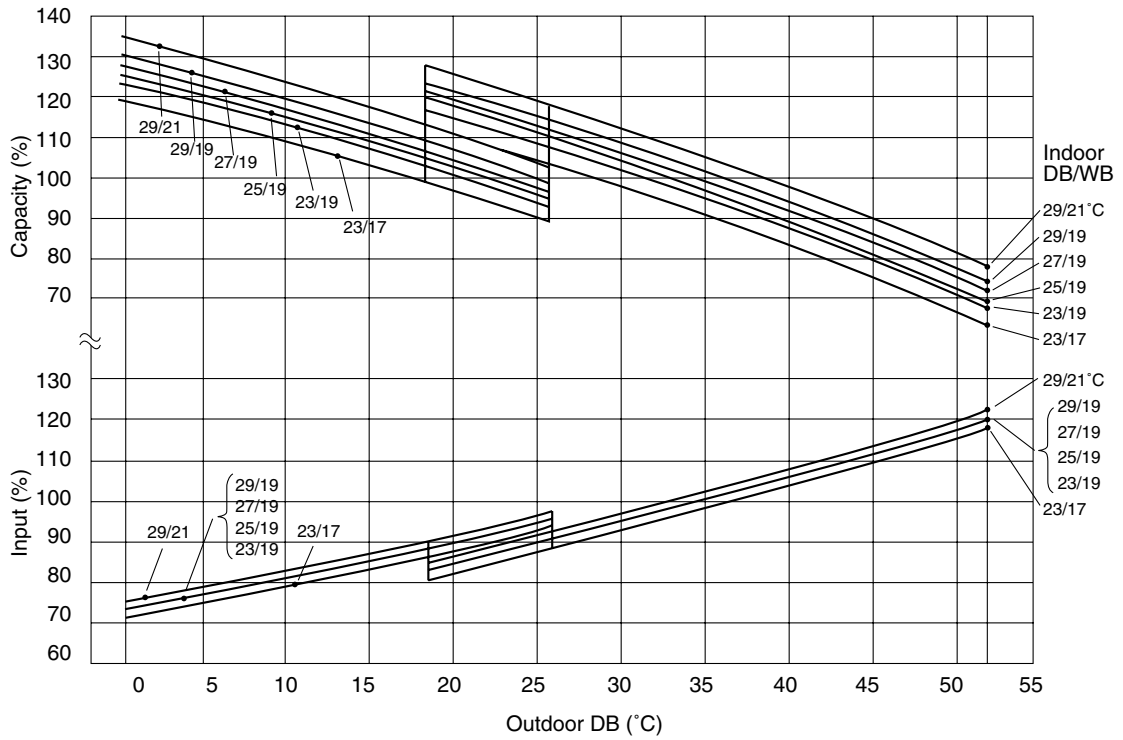

HEATING

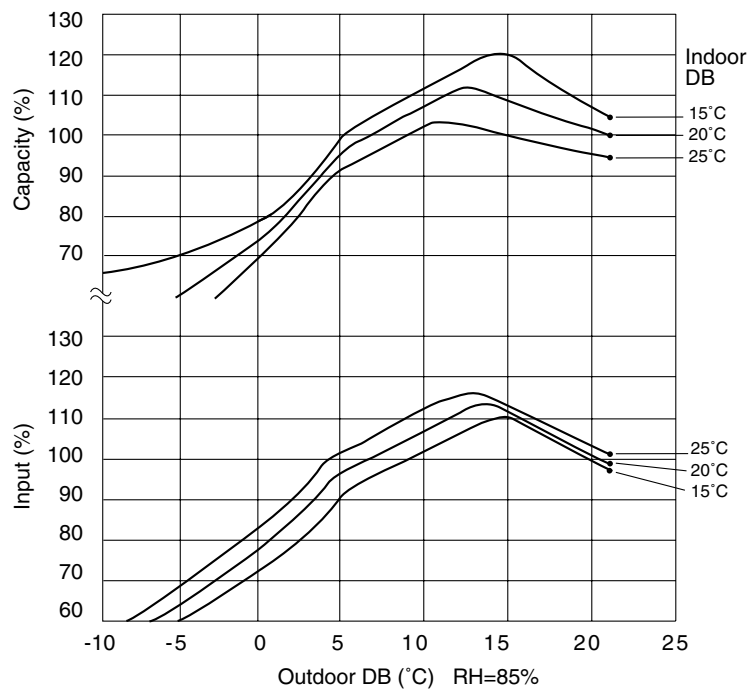

3 - 4. AIR VELOCITY DISTRIBUTION

UNIVERSAL FLOOR / CEILING TYPE

- MODEL : AB18 (FLOOR CONSOLE)

TOP VIEW
 VERTICAL : Forward
 HORIZONTAL : Center

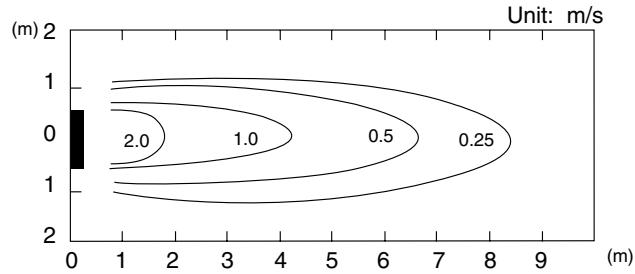

TOP VIEW
 VERTICAL : Forward
 HORIZONTAL : Right & Left

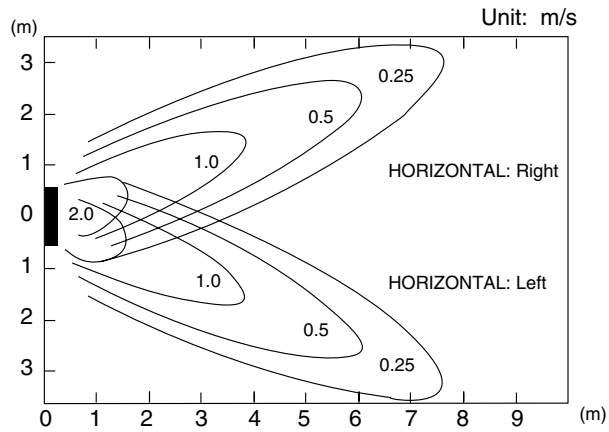

Condition
 Fan speed : High
 Operation mode : Fan
 Voltage : 240V

SIDE VIEW
 VERTICAL : Forward
 HORIZONTAL : Center

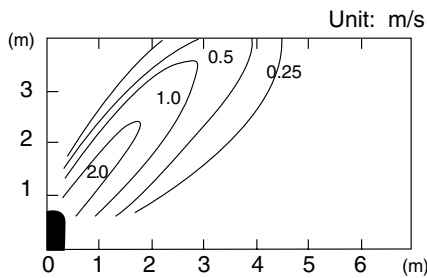
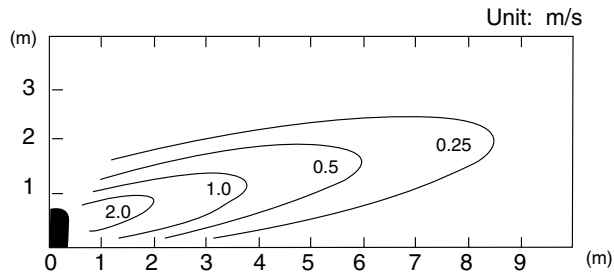

SIDE VIEW
 VERTICAL : Center
 HORIZONTAL : Center

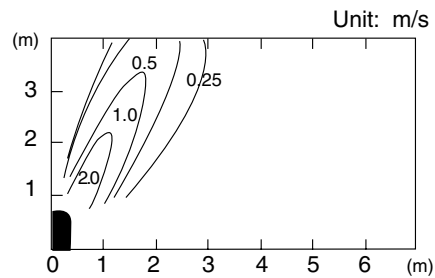

SIDE VIEW
 VERTICAL : Up
 HORIZONTAL : Center

● MODEL : AB18 (UNDER CEILING)

TOP VIEW
 VERTICAL : Up
 HORIZONTAL : Center

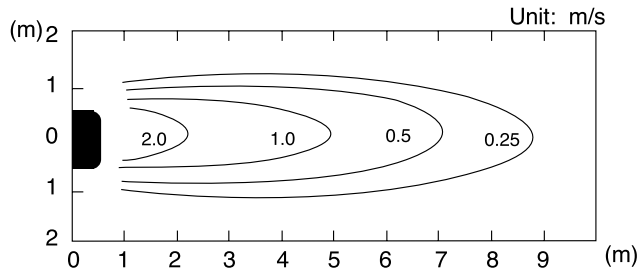

TOP VIEW
 VERTICAL : Up
 HORIZONTAL : Right & Left

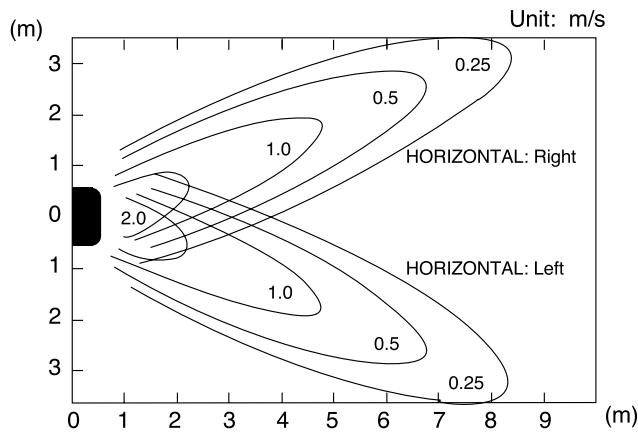

Condition
 Fan speed : High
 Operation mode : Fan
 Voltage : 240V

SIDE VIEW
 VERTICAL : Forward
 HORIZONTAL : Center

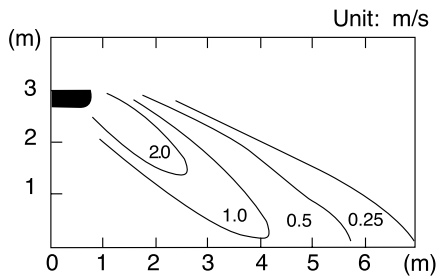
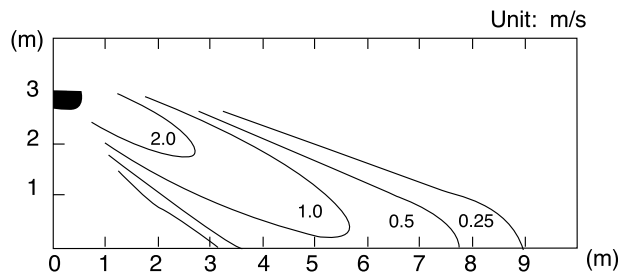

SIDE VIEW
 VERTICAL : Center
 HORIZONTAL : Center

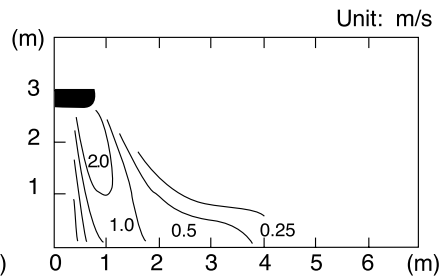

SIDE VIEW
 VERTICAL : Down
 HORIZONTAL : Center

UNIVERSAL FLOOR / CEILING TYPE

● MODEL : AB24 (FLOOR CONSOLE)

TOP VIEW
 VERTICAL : Forward
 HORIZONTAL : Center

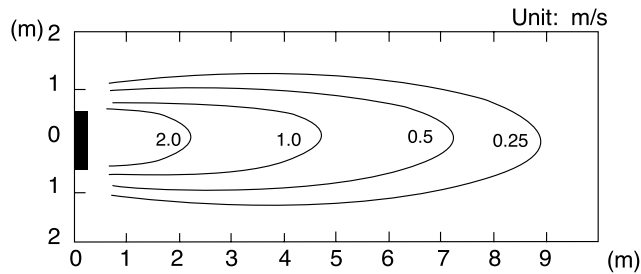

TOP VIEW
 VERTICAL : Forward
 HORIZONTAL : Right & Left

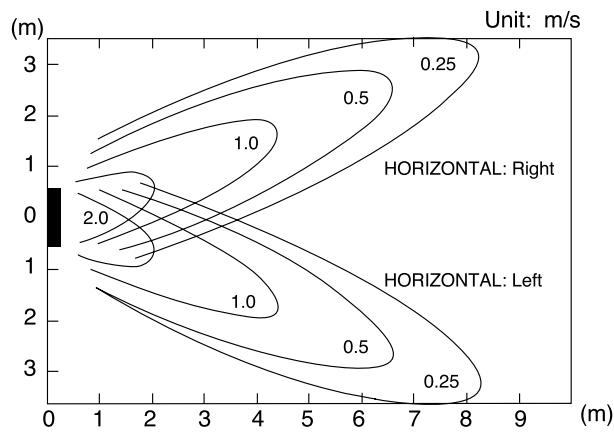

Condition
 Fan speed : High
 Operation mode : Fan
 Voltage : 240V (50Hz)
 220V (60Hz)

SIDE VIEW
 VERTICAL : Forward
 HORIZONTAL : Center

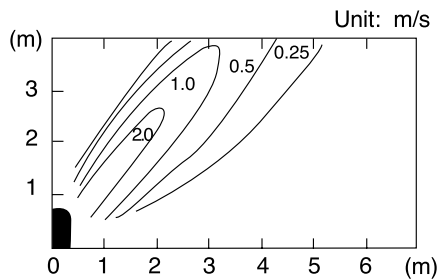
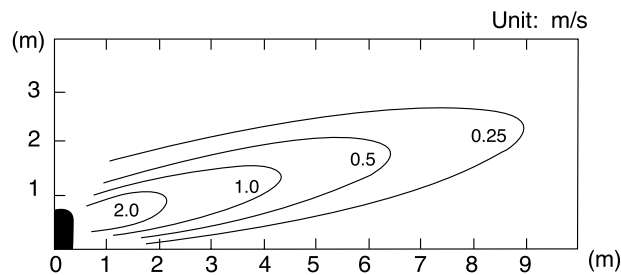

SIDE VIEW
 VERTICAL : Center
 HORIZONTAL : Center

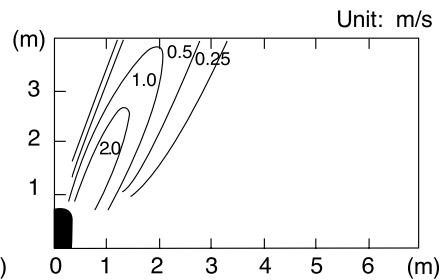

SIDE VIEW
 VERTICAL : Up
 HORIZONTAL : Center

● MODEL : AB24(UNDER CEILING)

TOP VIEW
 VERTICAL : Up
 HORIZONTAL : Center

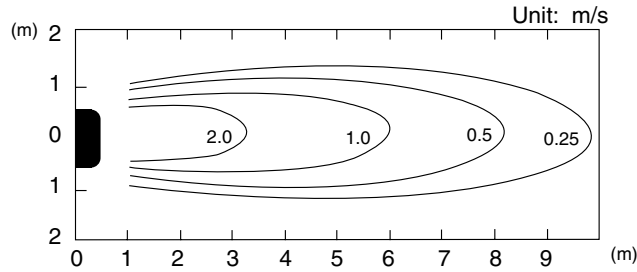

TOP VIEW
 VERTICAL : Up
 HORIZONTAL : Right & Left

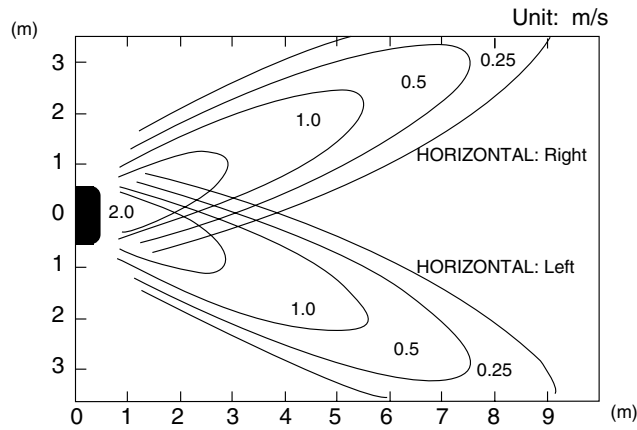

Condition
 Fan speed : High
 Operation mode : Fan
 Voltage : 240V (50Hz)
 220V (60Hz)

SIDE VIEW
 VERTICAL : Up
 HORIZONTAL : Center

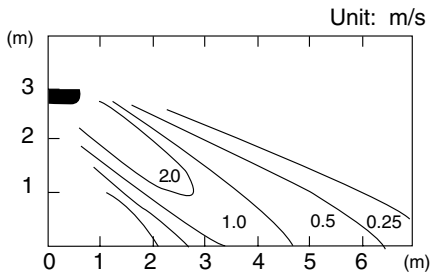
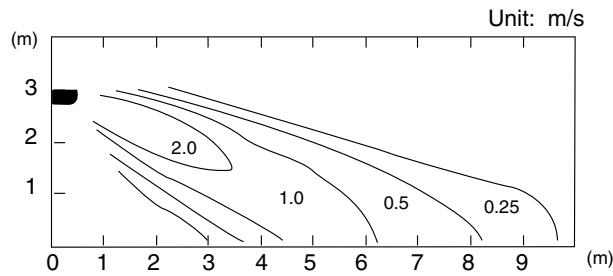

SIDE VIEW
 VERTICAL : Center
 HORIZONTAL : Center

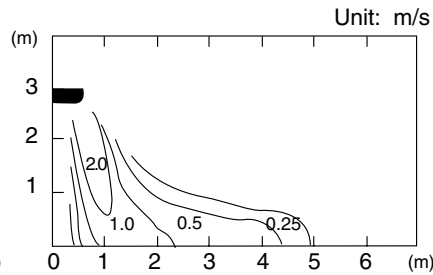

SIDE VIEW
 VERTICAL : Down
 HORIZONTAL : Center

LARGE CEILING TYPE

- MODEL : AB30

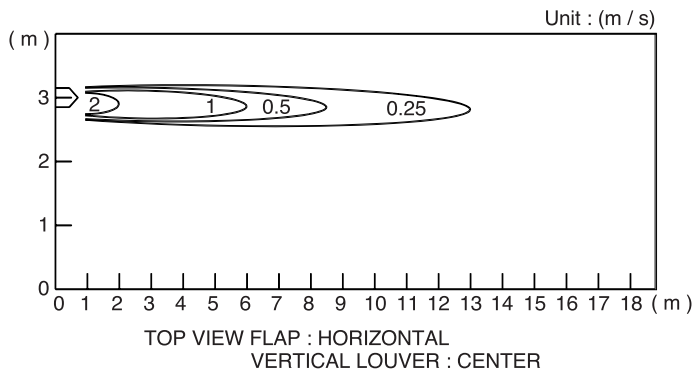
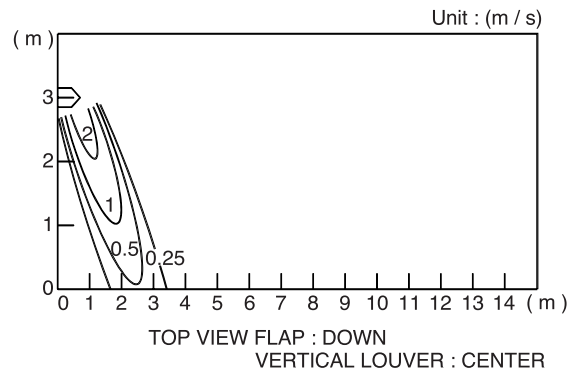
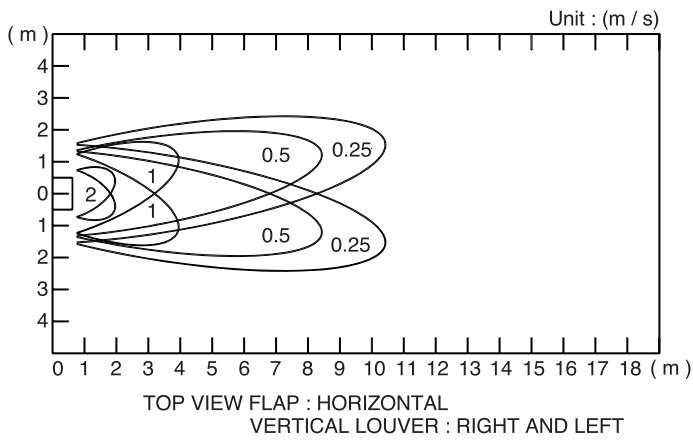
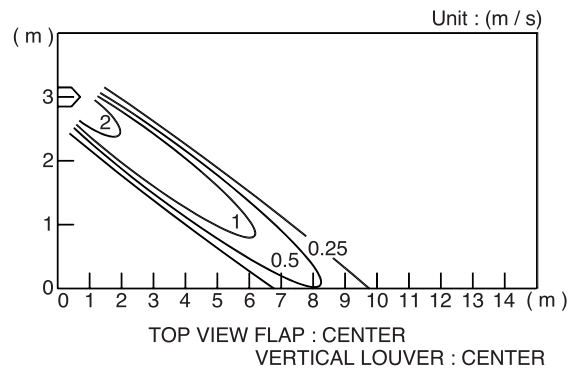
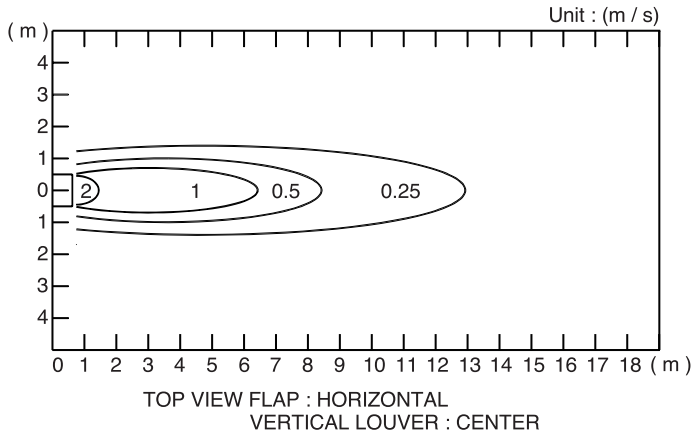

● MODEL : AB36

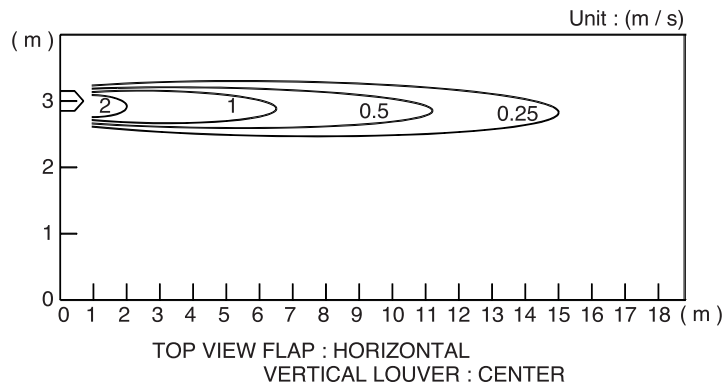
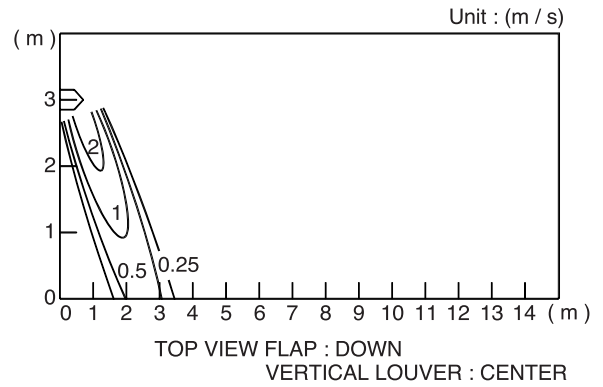
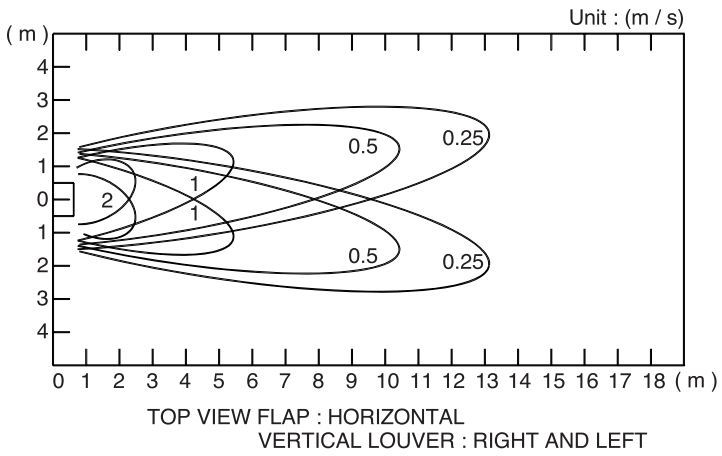
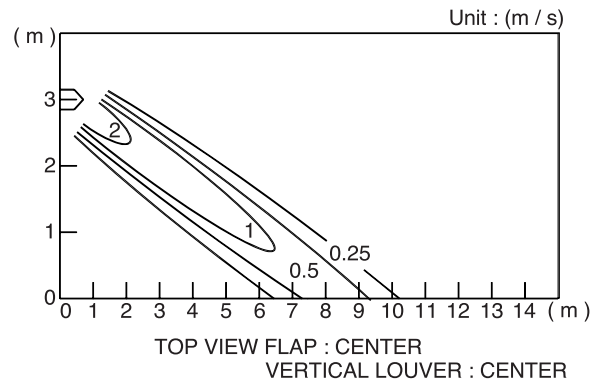
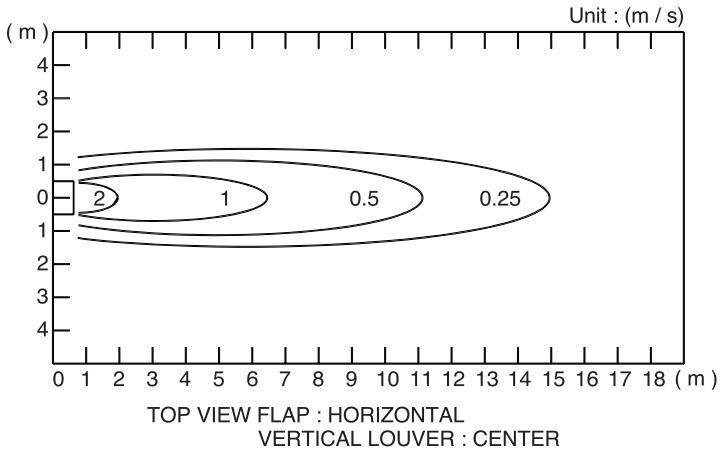

● MODEL : AB45

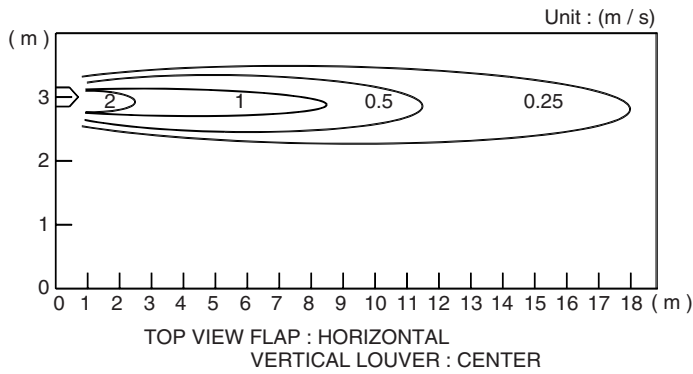
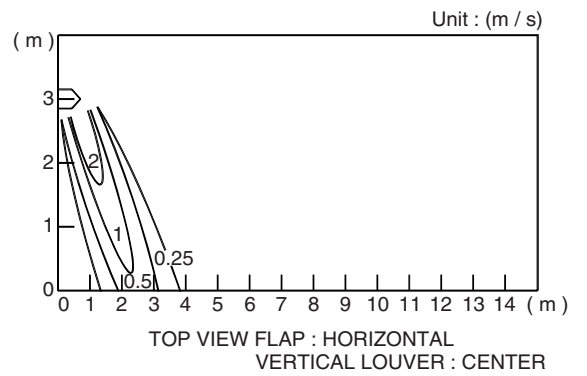
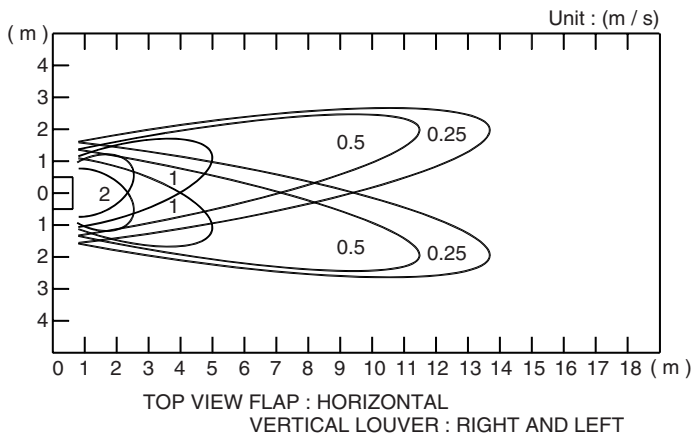
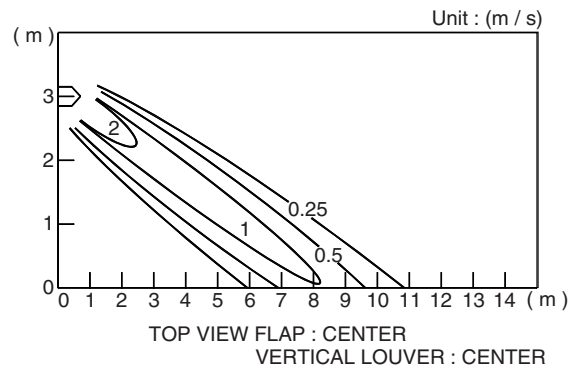
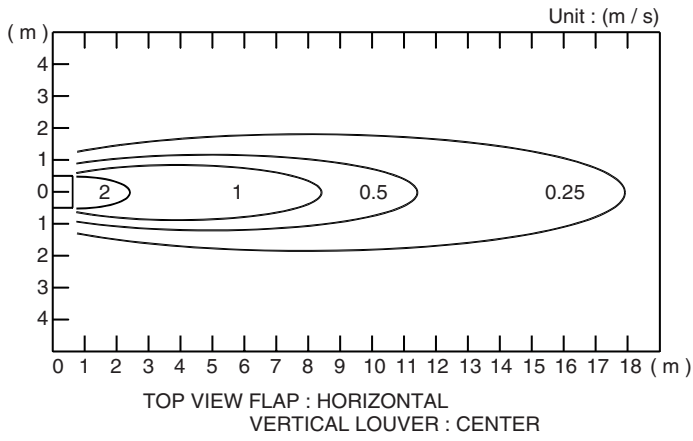

COMPACT CASSETTE TYPE

● MODEL : AU18

4-WAY AIR OUTLET

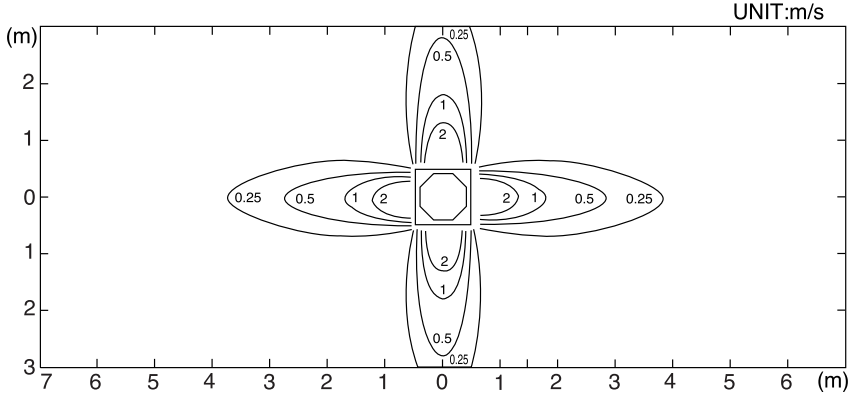

Note:
 Condition
 Fan speed: High
 Operation mode: FAN
 Voltage: 240V

TOP VIEW
 HORIZONTAL LOUVER:Up

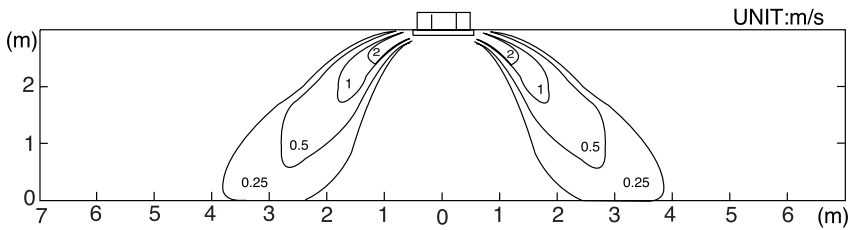

SIDE VIEW
 HORIZONTAL LOUVER:Up

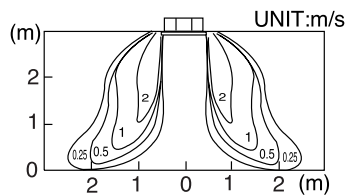

SIDE VIEW
 HORIZONTAL LOUVER:Down

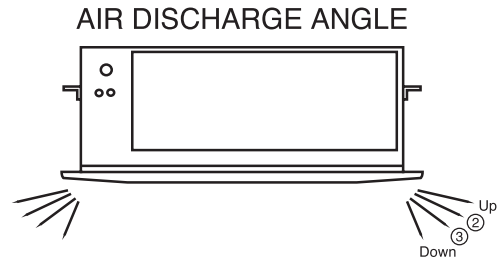

2-WAY AIR OUTLET

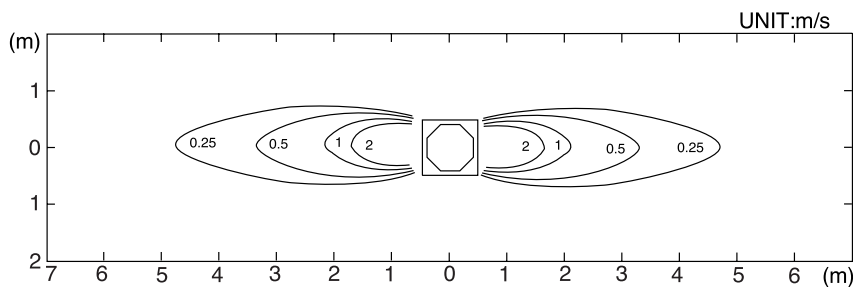

TOP VIEW
 HORIZONTAL LOUVER:Up

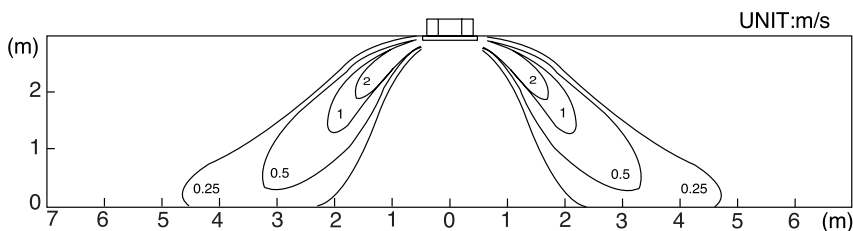

SIDE VIEW
 HORIZONTAL LOUVER:Up

CASSETTE TYPE

● MODEL : AU25

4-WAY AIR OUTLET

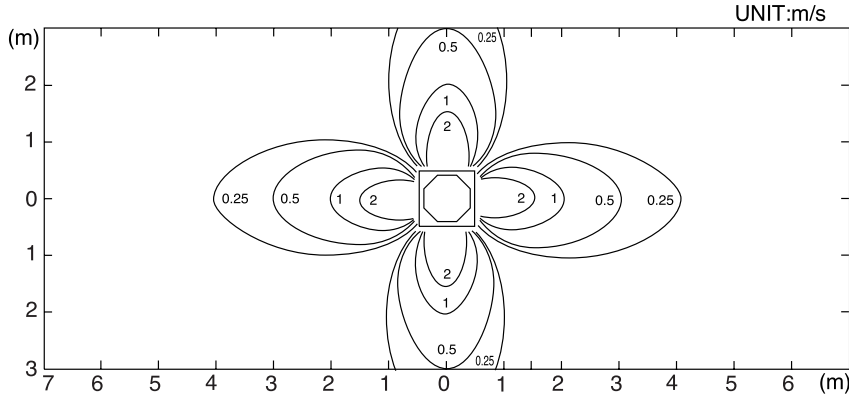

Note:

Condition
 Fan speed: High
 Operation mode: FAN
 Voltage: 240V

TOP VIEW
 HORIZONTAL LOUVER:Up

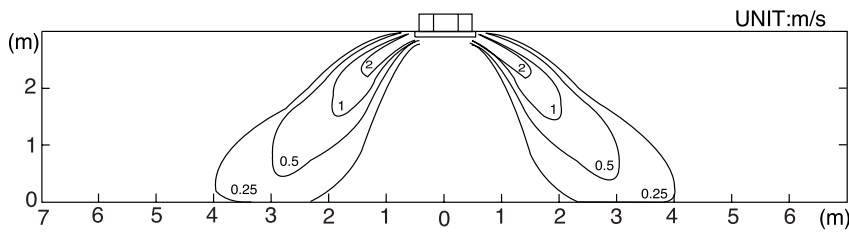

SIDE VIEW
 HORIZONTAL LOUVER:Up

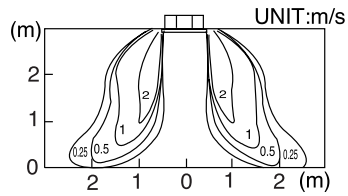

SIDE VIEW
 HORIZONTAL LOUVER:Down

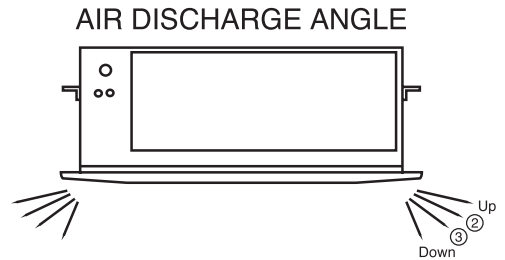

2-WAY AIR OUTLET

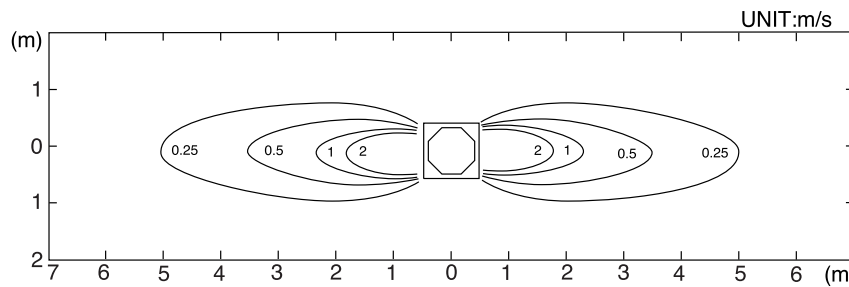

TOP VIEW
 HORIZONTAL LOUVER:Up

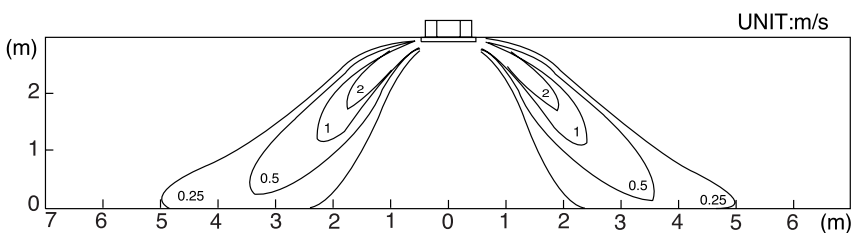

SIDE VIEW
 HORIZONTAL LOUVER:Up

● MODEL : AU30

4-WAY AIR OUTLET

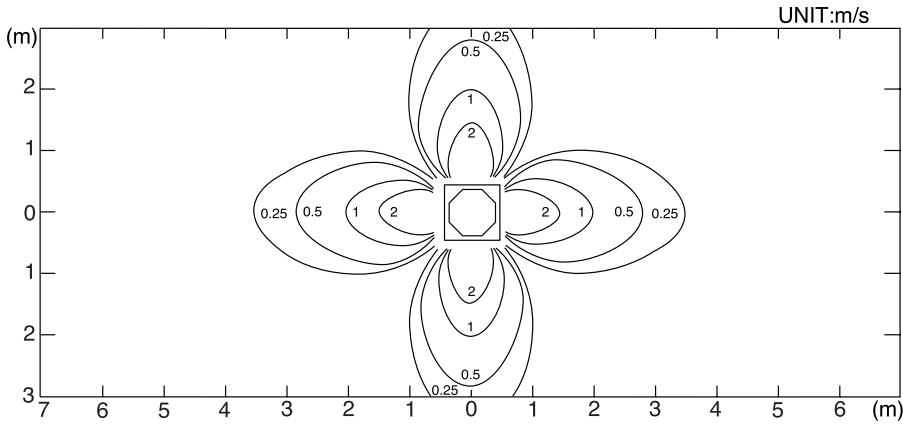

Note:
 Condition
 Fan speed: High
 Operation mode: FAN
 Voltage: 240V

TOP VIEW
 HORIZONTAL LOUVER:Up

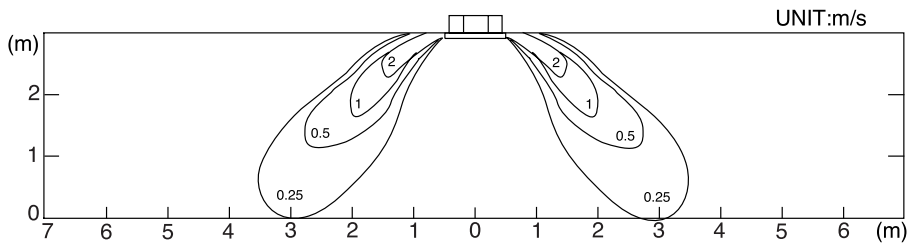

SIDE VIEW
 HORIZONTAL LOUVER:Up

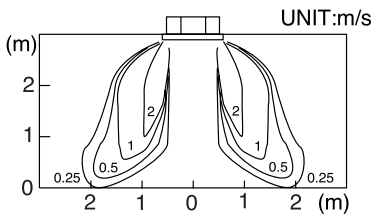

SIDE VIEW
 HORIZONTAL LOUVER:Down

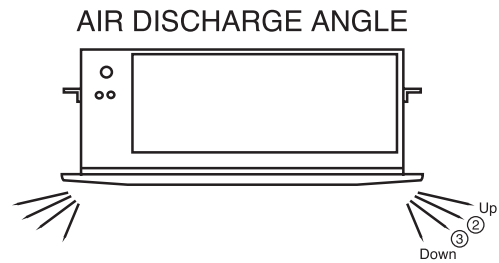

2-WAY AIR OUTLET

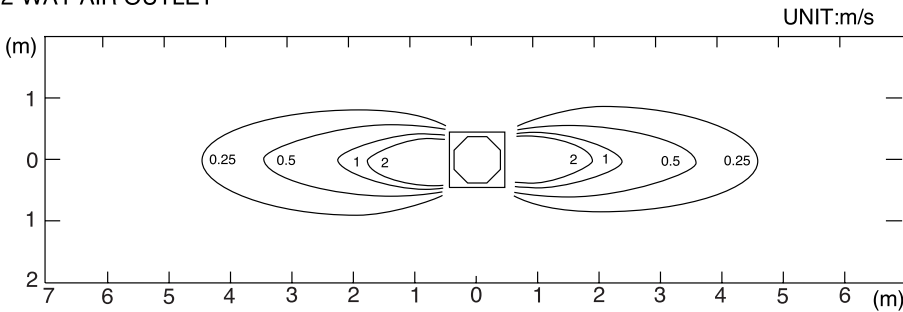

TOP VIEW
 HORIZONTAL LOUVER:Up

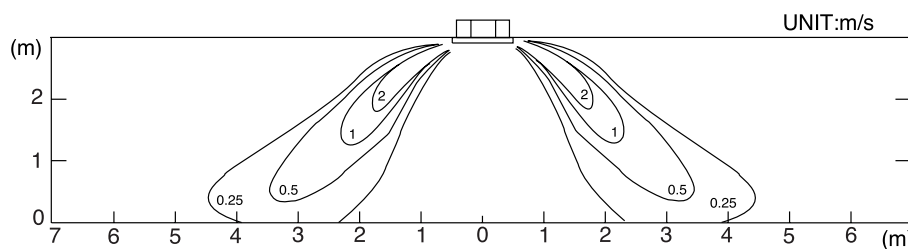

SIDE VIEW
 HORIZONTAL LOUVER:Up

● MODEL : AU36

4-WAY AIR OUTLET

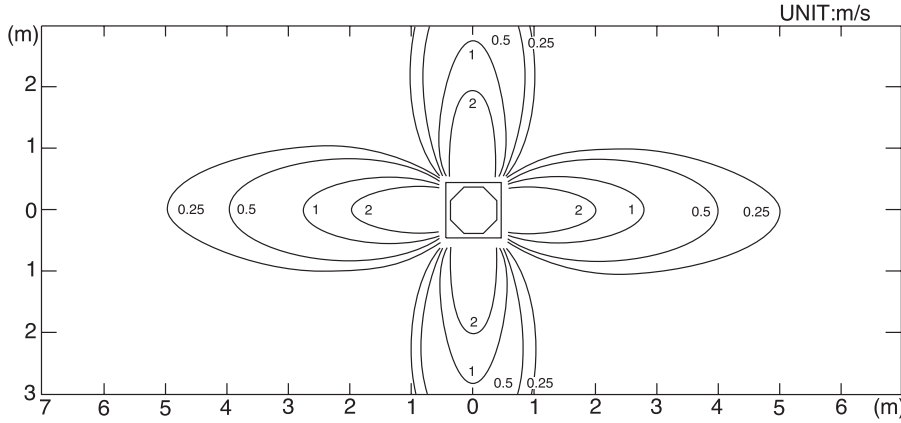

Note:

Condition
 Fan speed: High
 Operation mode: FAN
 Voltage: 240V

TOP VIEW
 HORIZONTAL LOUVER:Up

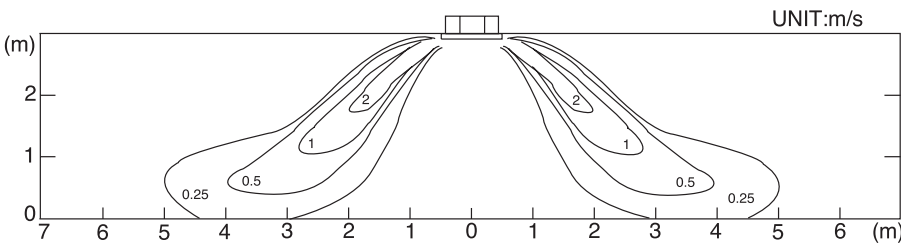

SIDE VIEW
 HORIZONTAL LOUVER:Up

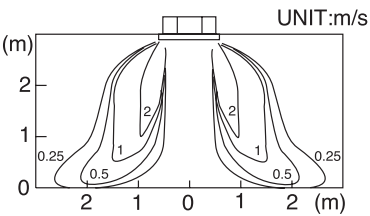

SIDE VIEW
 HORIZONTAL LOUVER:Down

AIR DISCHARGE ANGLE

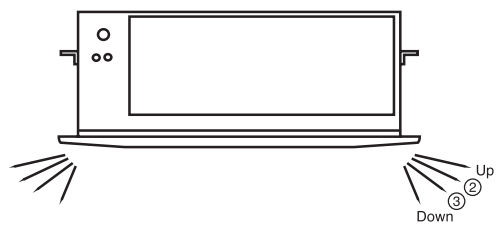

2-WAY AIR OUTLET

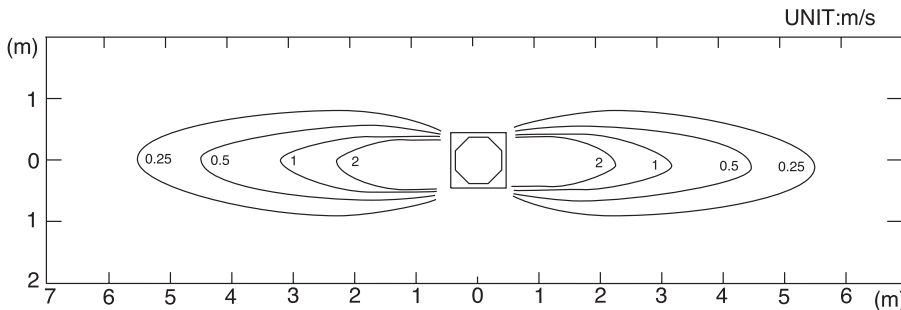

TOP VIEW
 HORIZONTAL LOUVER:Up

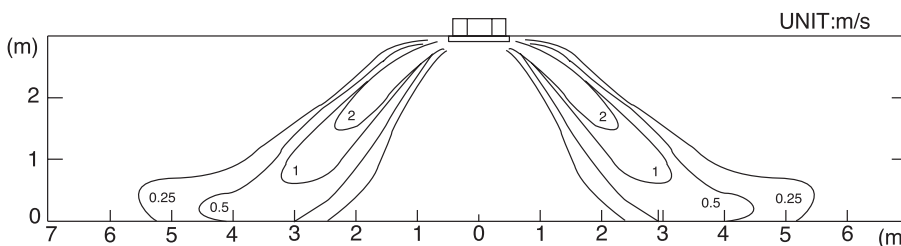

SIDE VIEW
 HORIZONTAL LOUVER:Up

● MODEL : AU45

4-WAY AIR OUTLET

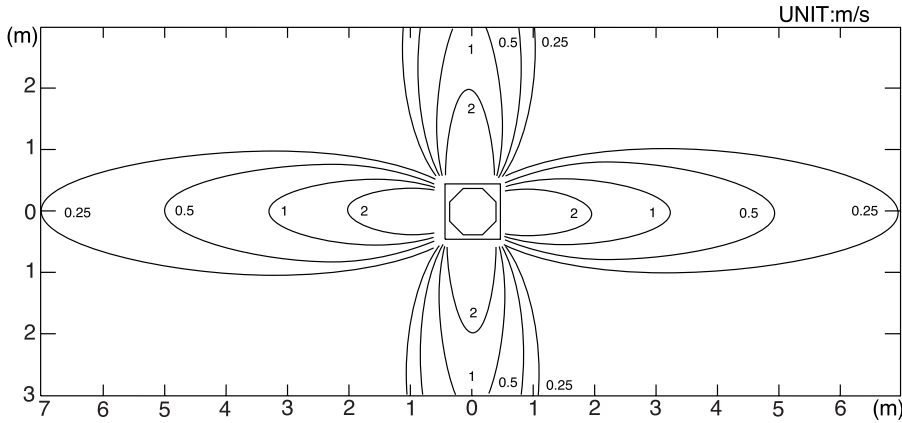

Note:
 Condition
 Fan speed: High
 Operation mode: FAN
 Voltage: 240V

TOP VIEW
 HORIZONTAL LOUVER:Up

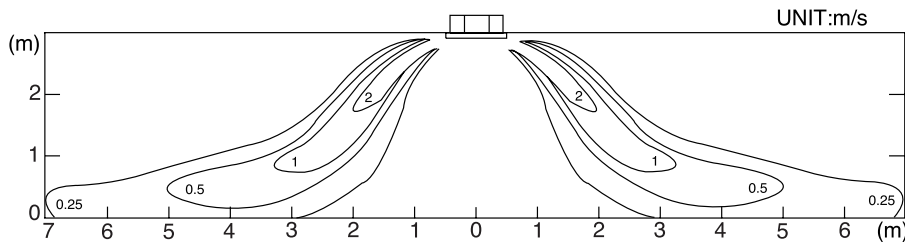

SIDE VIEW
 HORIZONTAL LOUVER:Up

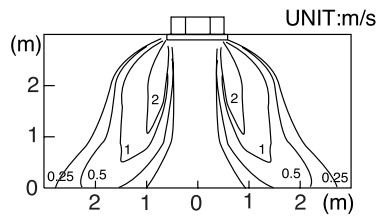

SIDE VIEW
 HORIZONTAL LOUVER:Down

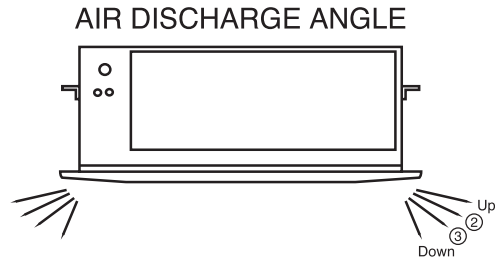

2-WAY AIR OUTLET

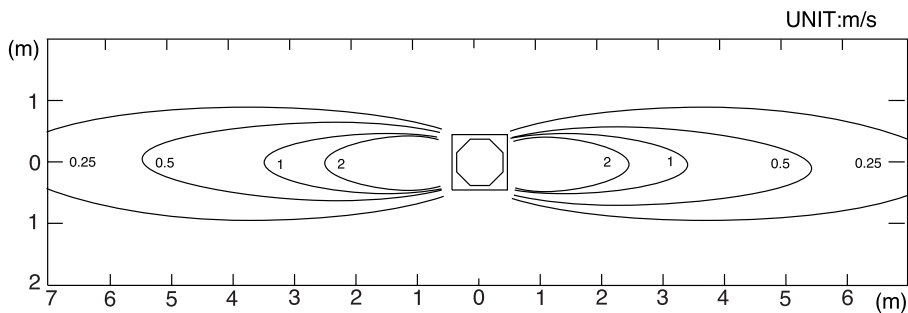

TOP VIEW
 HORIZONTAL LOUVER:Up

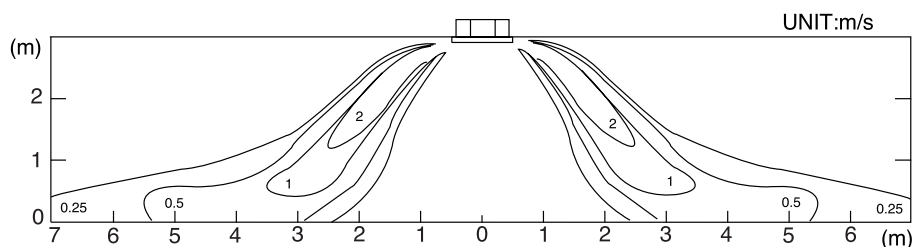

SIDE VIEW
 HORIZONTAL LOUVER:Up

3 - 5. SOUND LEVEL CURVE

UNIVERSAL FLOOR / CEILING TYPE, CEILING TYPE

- MODELS : AB18, AB24, AB30, AB36, AB45

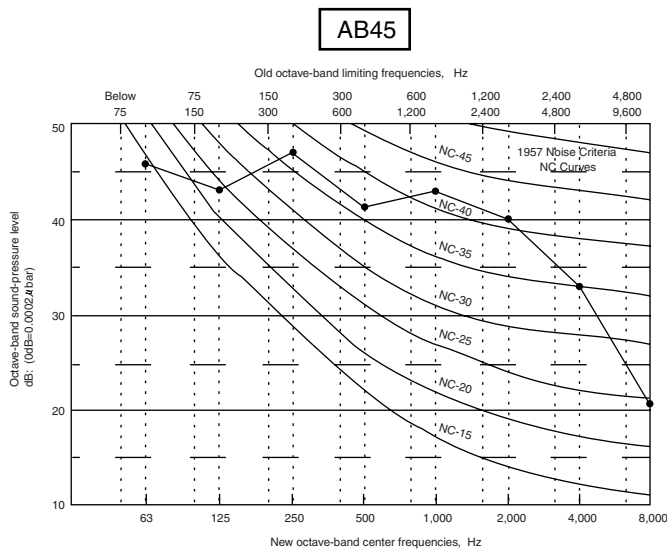
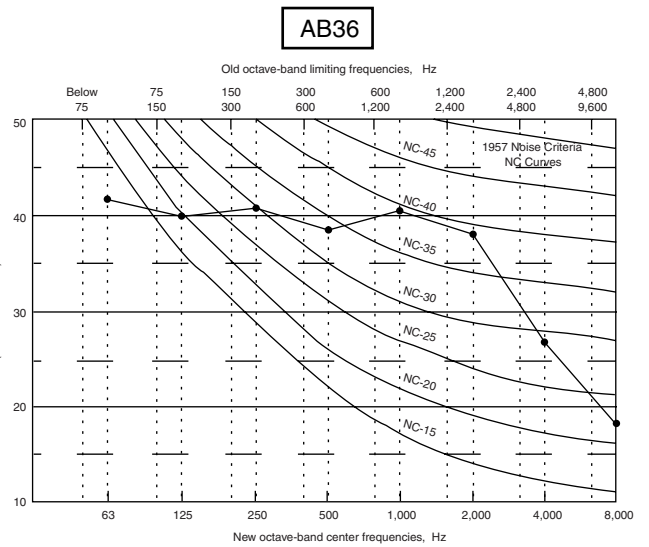
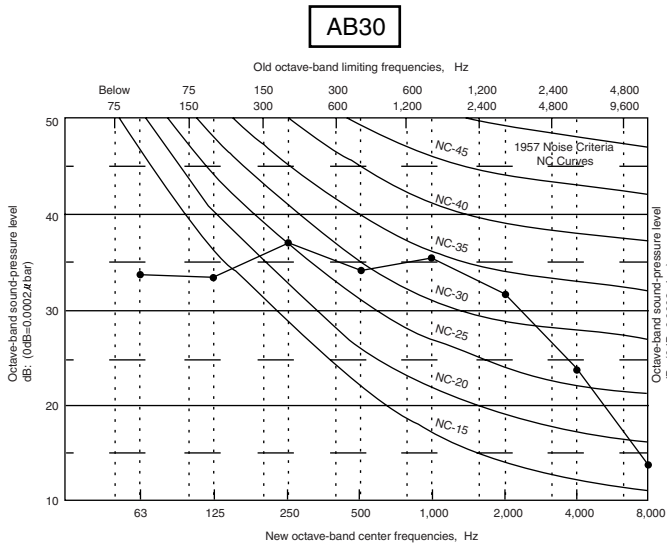
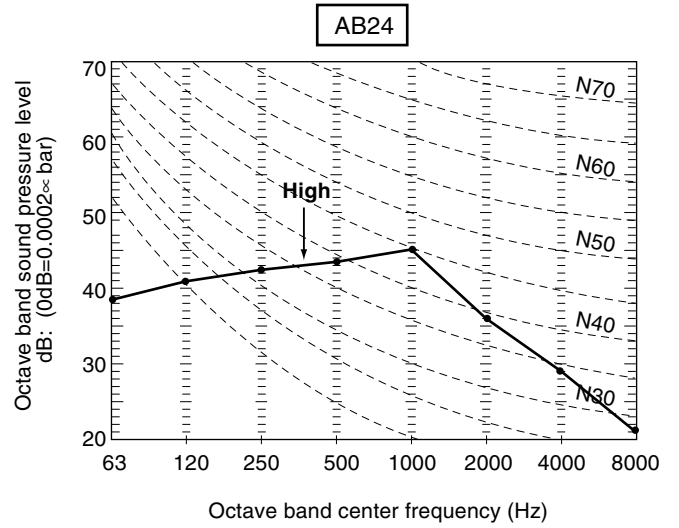
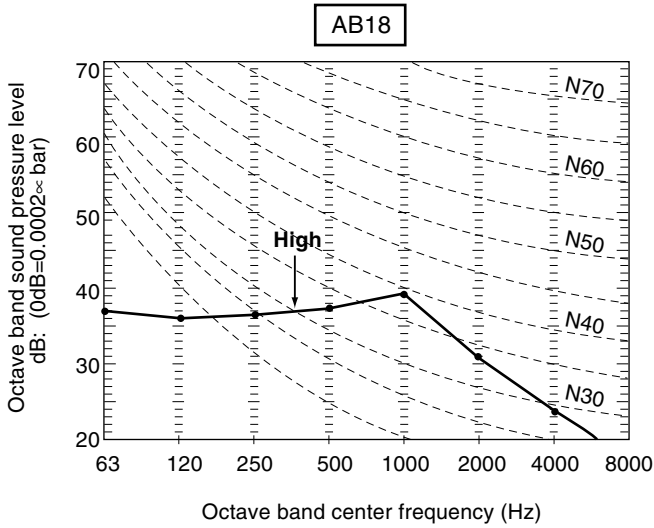

CASSETTE TYPE

- MODELS : AU18, AU25, AU30, AU36, AU45

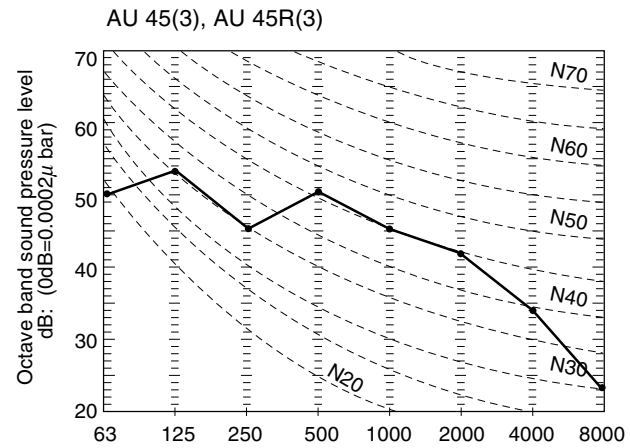
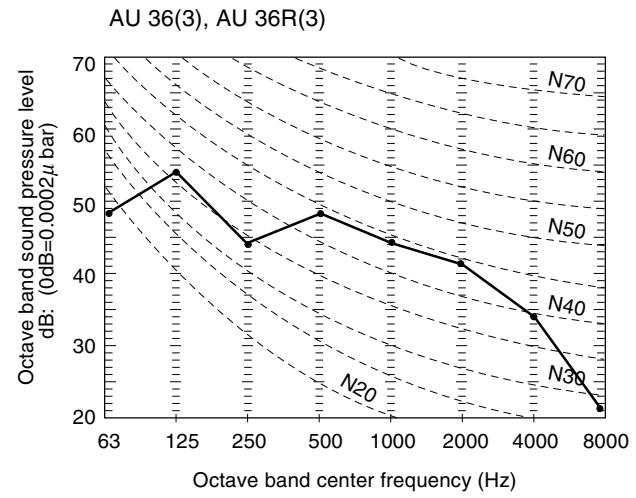
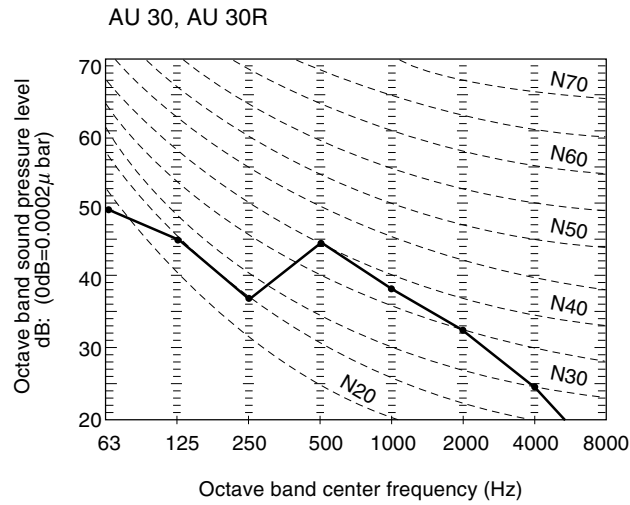
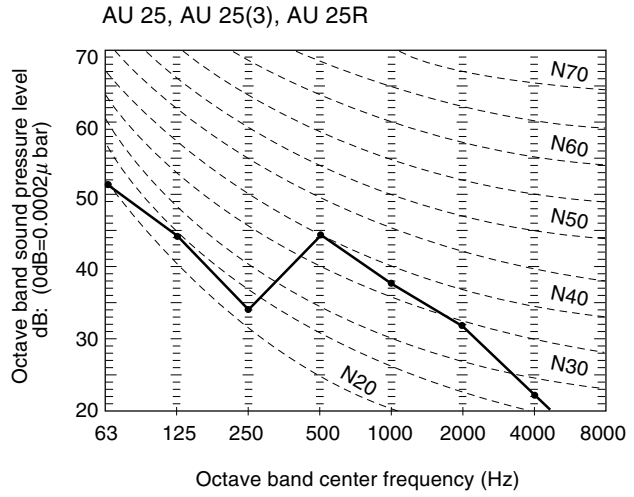
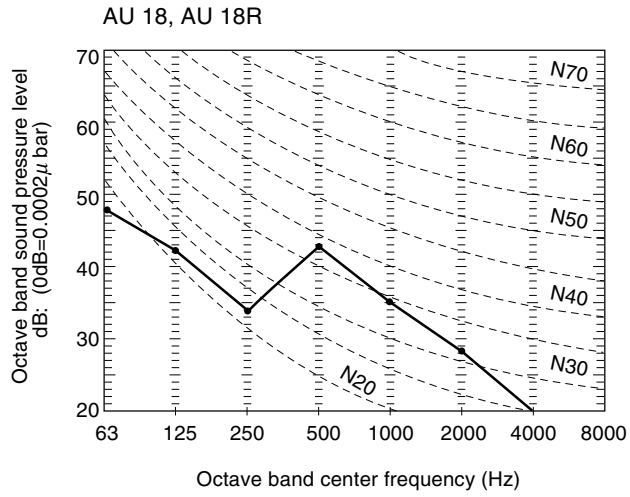

3 - 6. REFRIGERANT CHARGING

(g)

Model		Pipe length	16ft (5m) ~ 99ft (30m)	132ft (40m)	165ft (50m)	Additional refrigerant g/m
FULL CHARGE AMOUNT	AO90TP3L		6,000	7,000	8,000	100
	AO90EP3L		6,000	7,000	8,000	100
	AO90TPMA		3,100 + 3,100	3,500	3,900	40
	AO90EPMA		3,100 + 3,100	3,500	3,900	40

3 - 7. FRESH AIR

CEILING TYPE

- MODELS : AB30, AB36, AB45

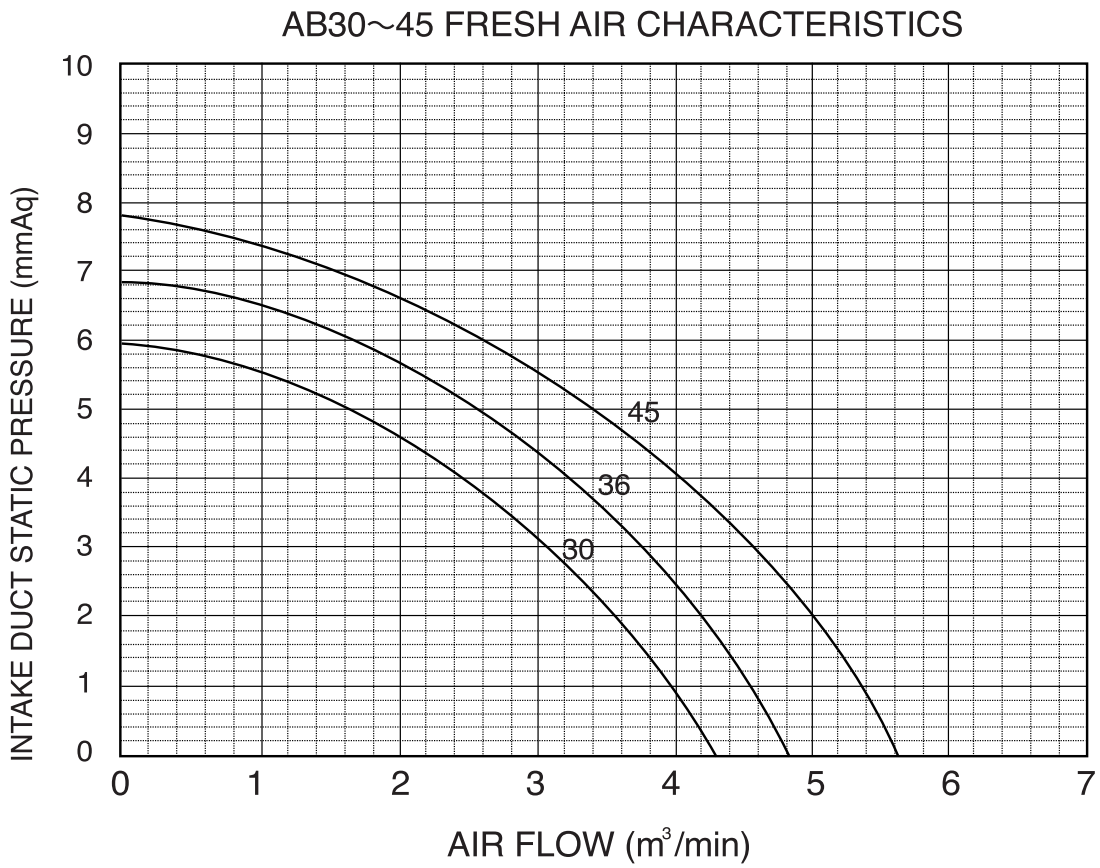

COMPACT CASSETTE TYPE

- MODELS : AU18

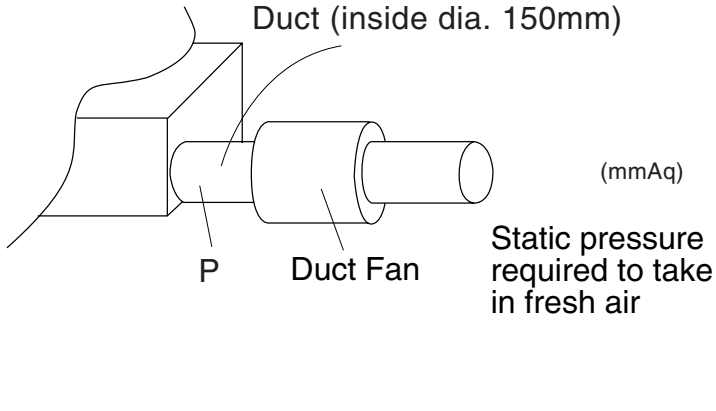

CASSETTE TYPE

- MODELS : AU25, AU30, AU36, AU45

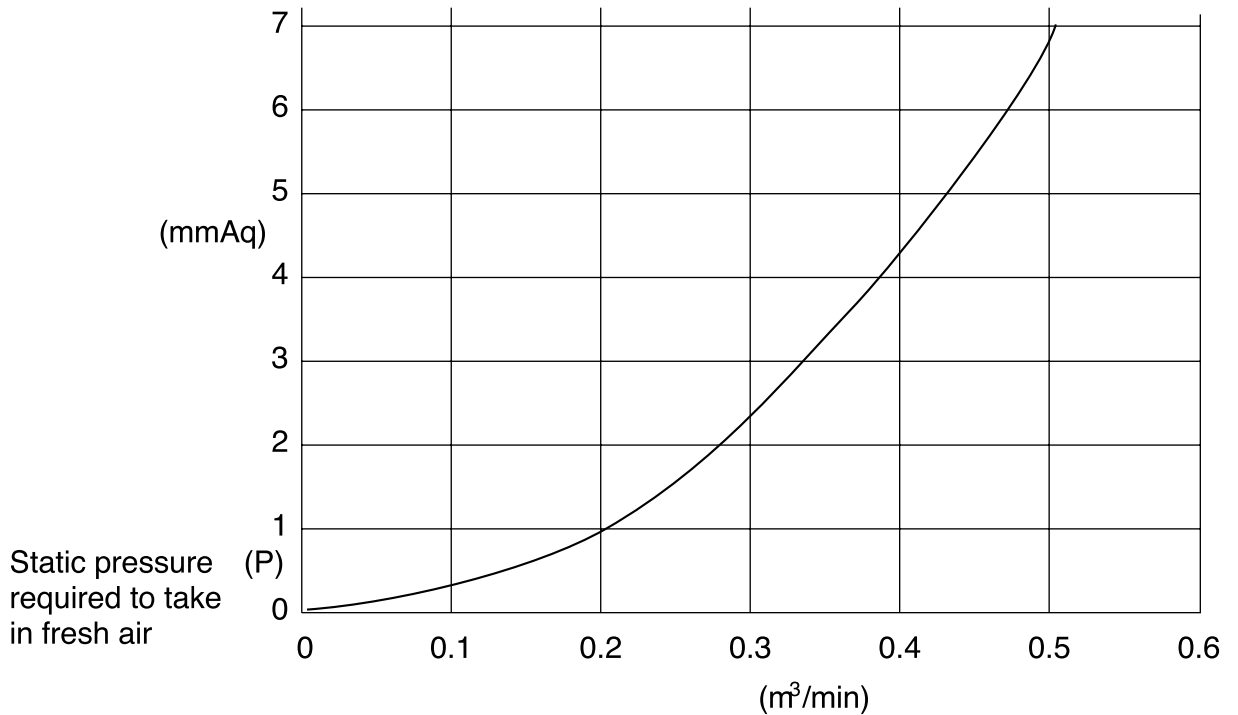
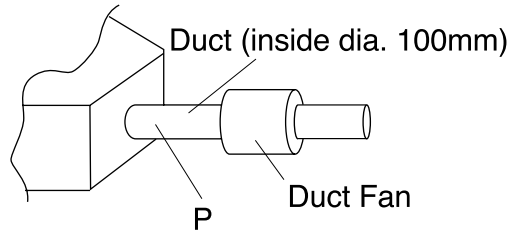

3 - 8. OUTLET AIR

COMPACT CASSETTE TYPE

- MODELS : AU18

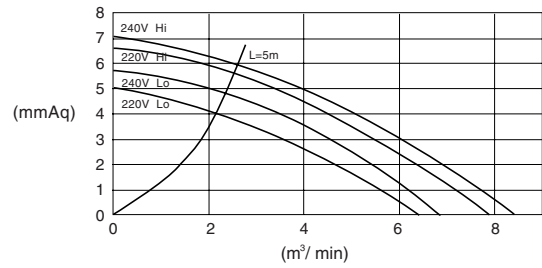
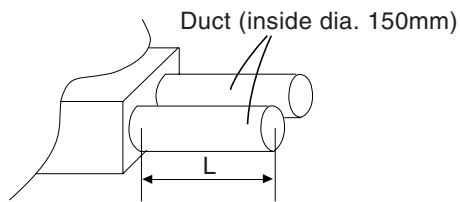
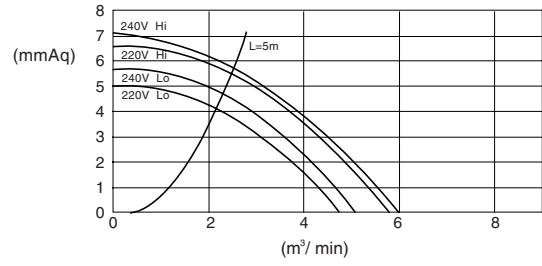
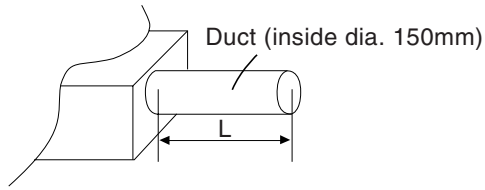

CASSETTE TYPE

- MODELS : AU30, AU36, AU45

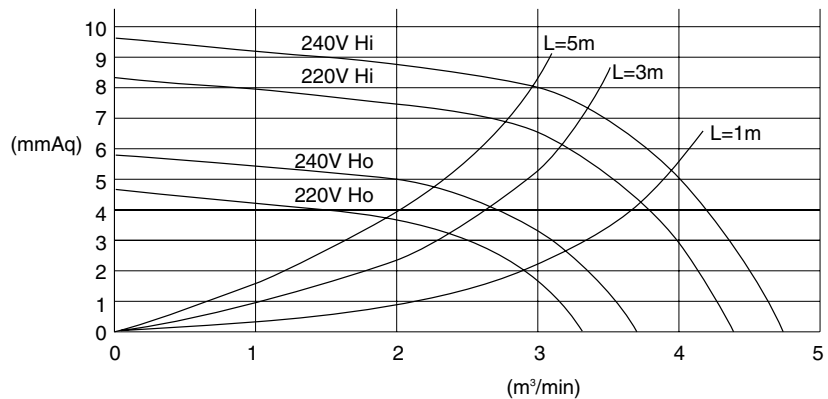
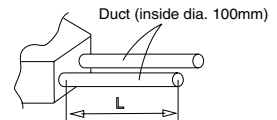
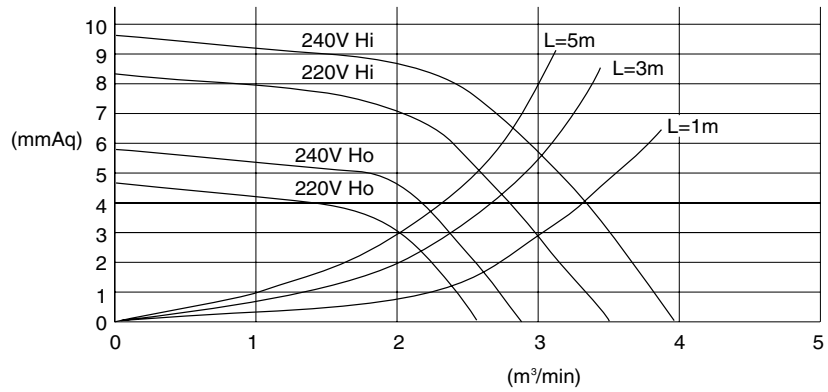
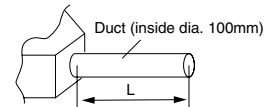

3 - 9. TEMPERATURE RANGE

Mode	Temperature Range	
	Indoor Unit	Outdoor Unit
COOL (DRY)	18 ~ 32 °C	0 ~ 52 °C
HEAT	30 °C or less	-10 ~ 21 °C

3 - 10. OTHERS

■ FAN CURVES (LOW STATIC PRESSURE DUCT TYPE)

- MODELS: AR25, AR30, AR36, AR45

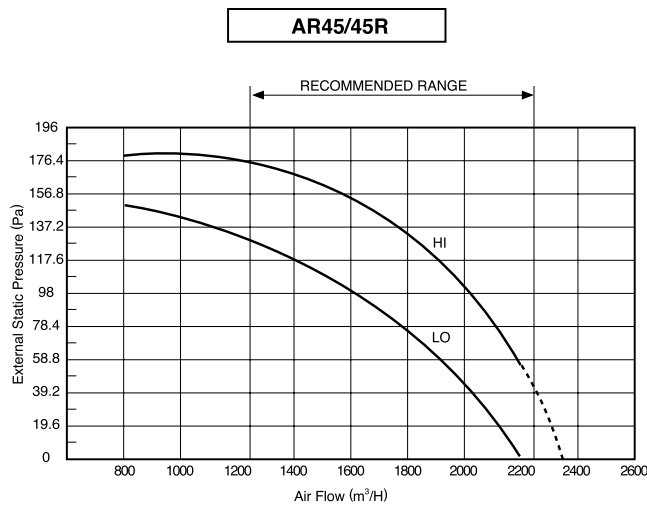
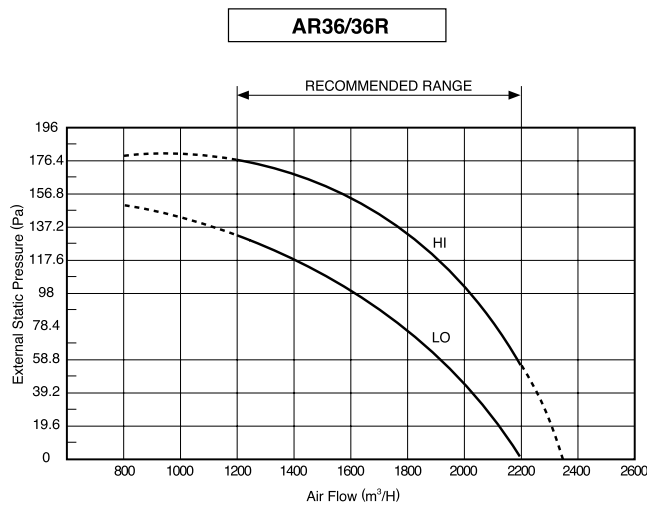
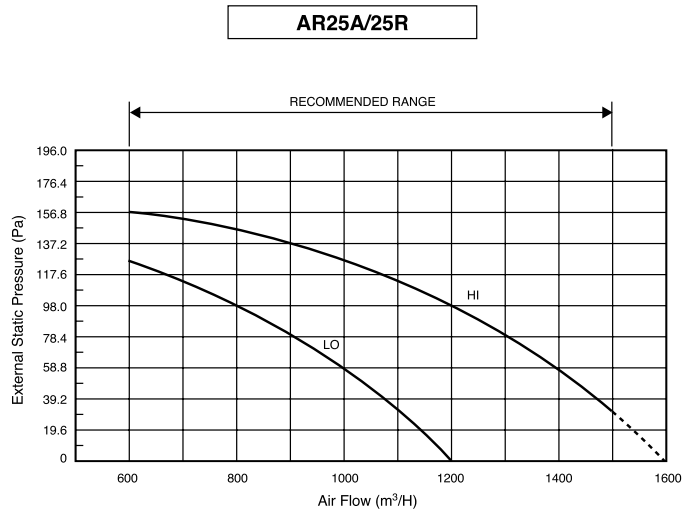

■ FAN CURVES (HIGH STATIC PRESSURE DUCT TYPE)

- MODELS : AR36H, AR45H

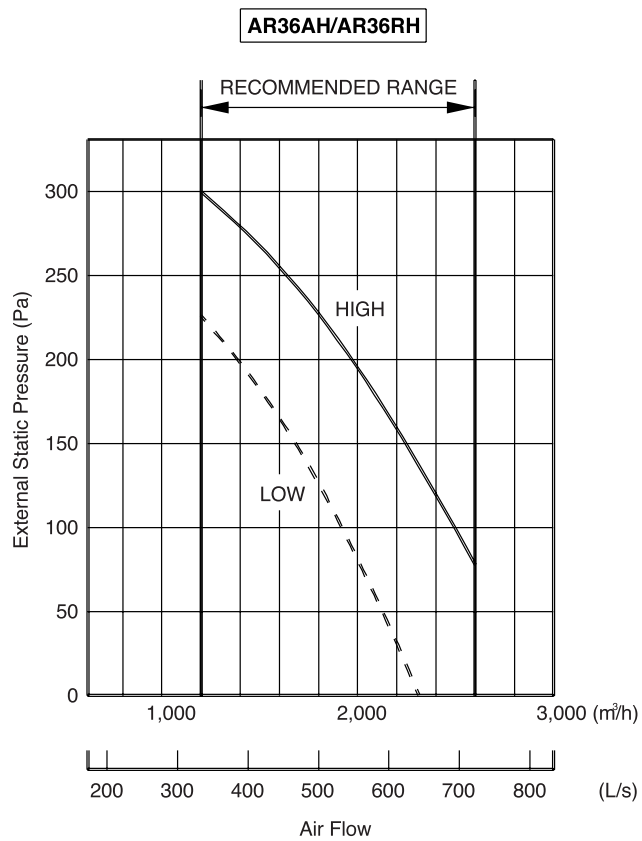
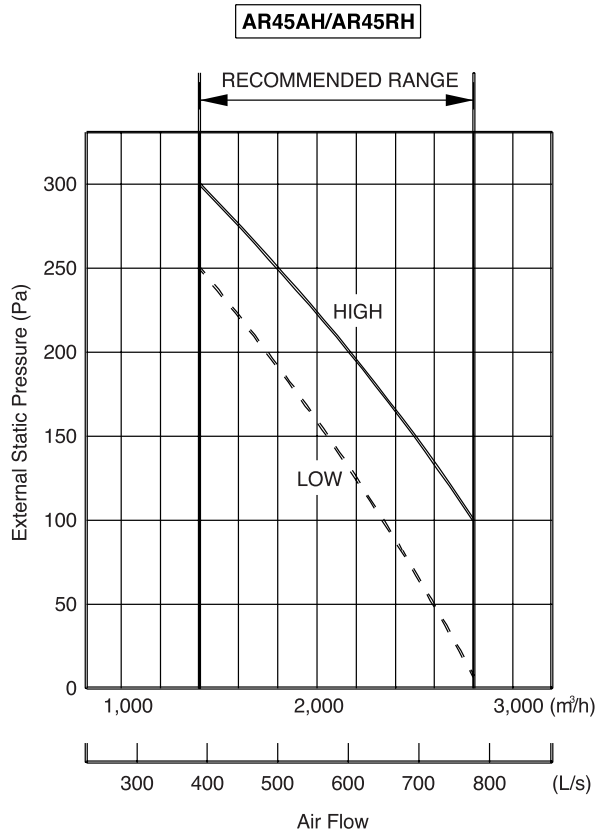

■ CAPACITY BY AIR FLOW (LOW STATIC PRESSURE DUCT TYPE)

- MODEL : AR25, AR30

●Cooling

(Condition: Inlet Air Temp. 27°C, Outdoor Temp 35°C.)

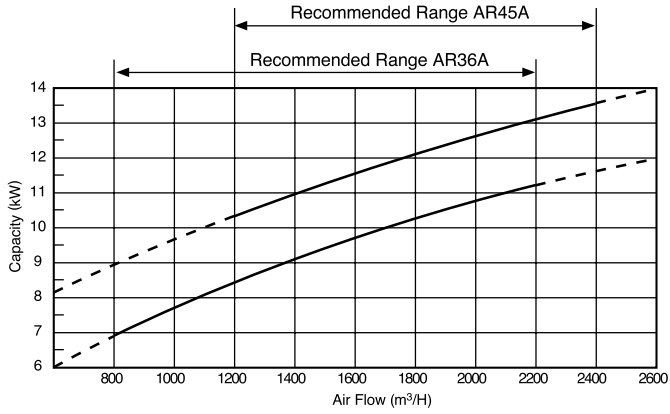

●Heating

(Condition: Inlet Air Temp. 20°C, Outdoor Temp 7°C.)

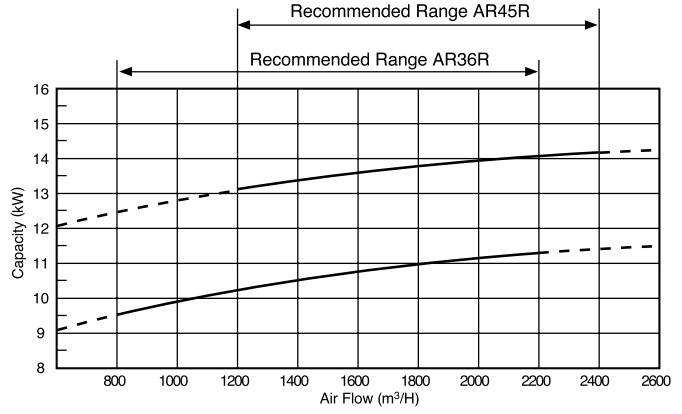

MODELS : AR36, AR45

●Cooling

(Condition: Inlet Air Temp. 27°C, Outdoor Temp 35°C.)

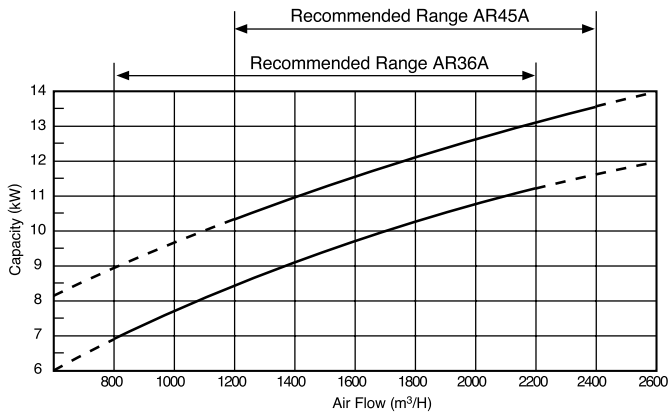

●Heating

(Condition: Inlet Air Temp. 20°C, Outdoor Temp 7°C.)

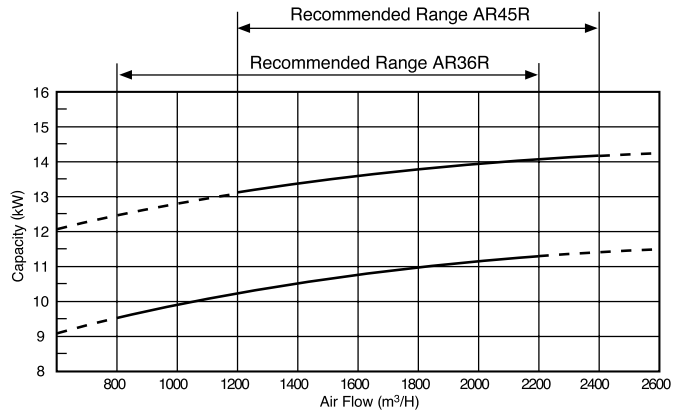

■ CAPACITY BY AIR FLOW (HIGH STATIC PRESSURE DUCT TYPE)

- MODELS : AR36, AR45

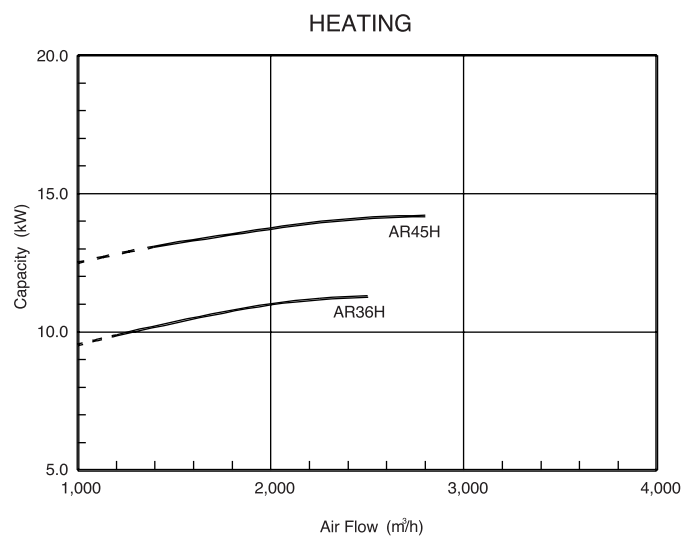
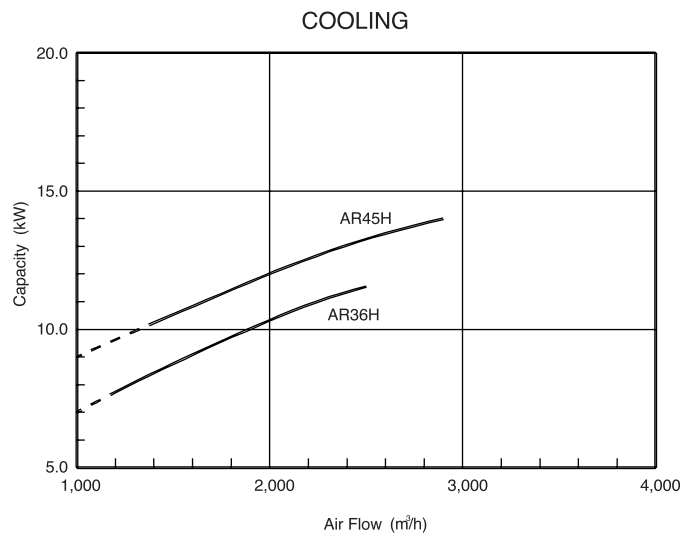

■ OUTLET AIR TEMPERATURE (LOW STATIC PRESSURE DUCT TYPE)

● MODEL : AR25, AR30

● Cooling

(Condition: Inlet Air Temp. 27°C, Outdoor Temp 35°C.)

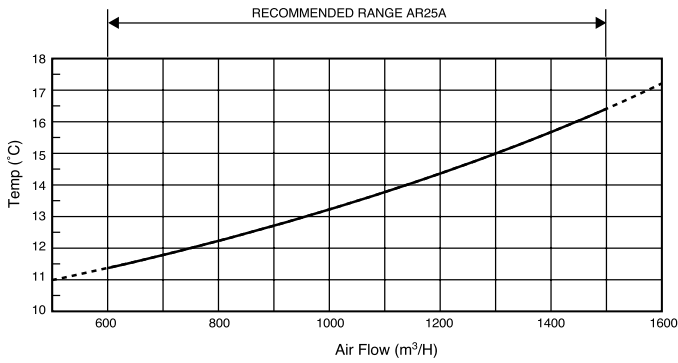

● Heating

(Condition: Inlet Air Temp. 20°C, Outdoor Temp 7°C.)

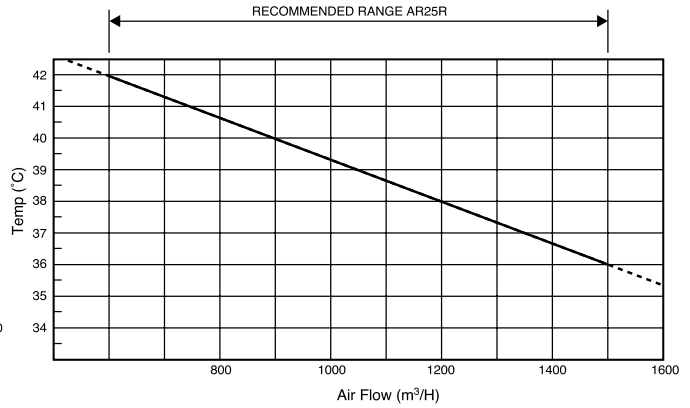

MODELS : AR36, AR45

● Cooling

(Condition: Inlet Air Temp. 27°C, Outdoor Temp 35°C.)

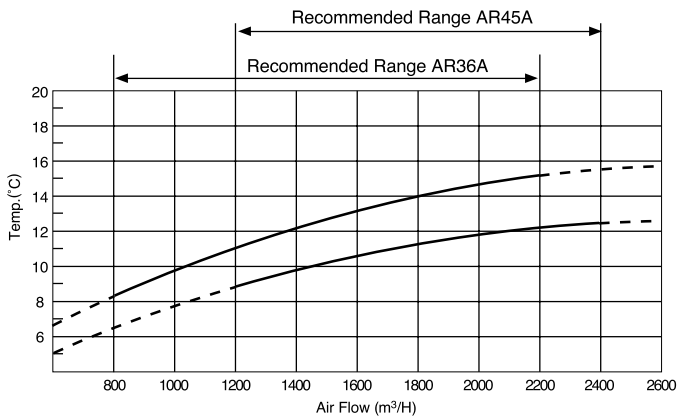

● Heating

(Condition: Inlet Air Temp. 20°C, Outdoor Temp 7°C.)

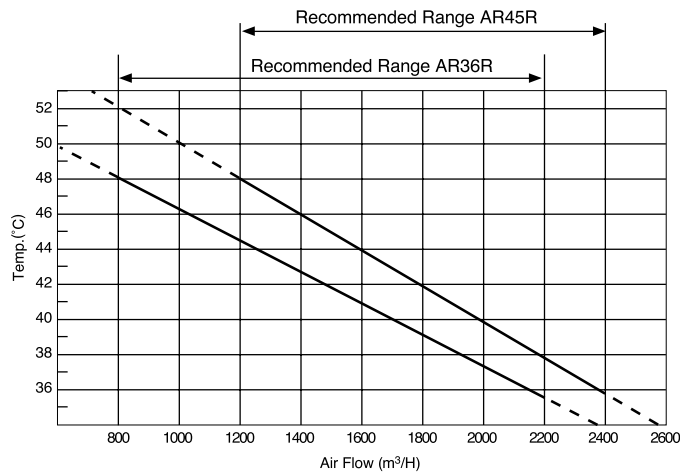

■ OUTLET AIR TEMPERATURE (HIGH STATIC PRESSURE DUCT TYPE)

- MODELS : AR36, AR45

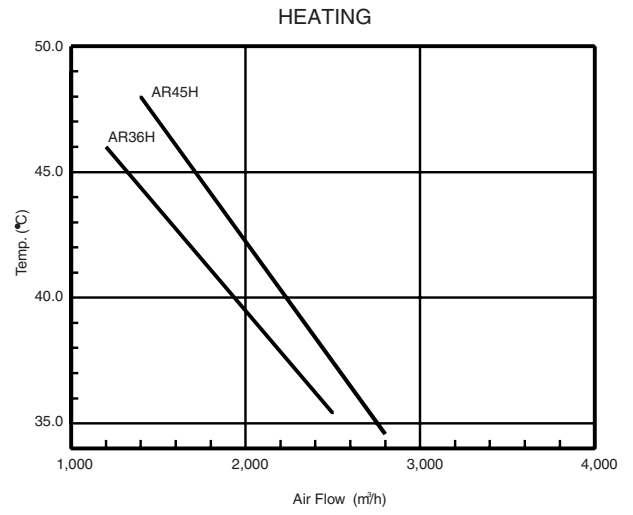
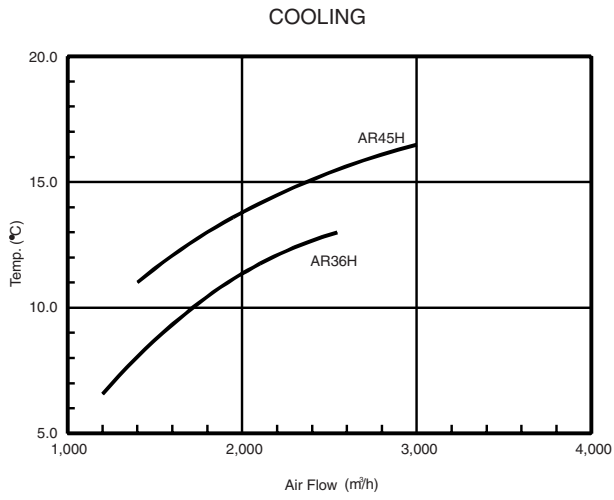

4. SYSTEM DESIGN RESTRICTIONS

4 - 1. OUTDOOR UNIT INSTALLATION

Single unit installation

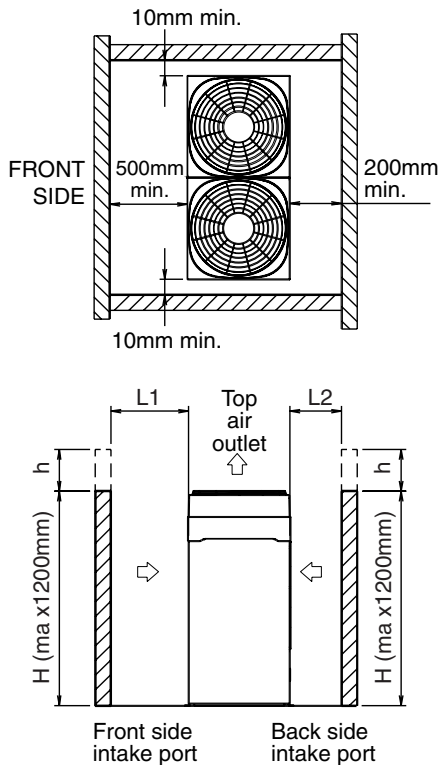

Consecutive units installation

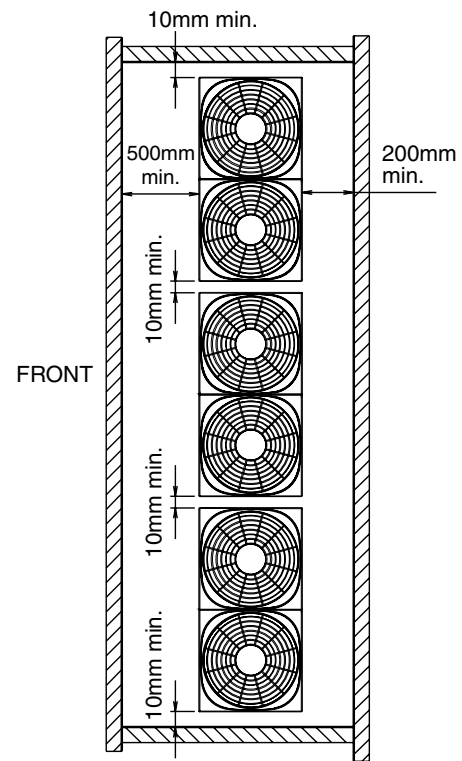

- Height of side wall is free.
- Height (H) of front wall is less than total height of outdoor unit (1,200mm).
- When total height of outdoor unit is lower than front wall, add dimension h to service space for dimensions L1 and L2.

SELECTING THE MOUNTING POSITION

Select the mounting position together with the customer.

- 1) During heating operation, drain water flows from the outdoor unit. Therefore, install the outdoor unit where the drain water flow will not be obstructed. [Heat & cool model (Reverse cycle) only]
- 2) Do not place animals and plants in the path of the warm air.
- 3) Take the air conditioner weight into account and select a place where noise and vibration are small.
- 4) Select a place so that the warm air and noise from the air conditioner do not disturb neighbors.
- 5) Provide the space shown above so that the air flow is not blocked.

5. OPTIONAL (SERVICE) PARTS

5 - 1. OPTIONAL (SERVICE) FOR BUILDING SYSTEM

Separation tube (ϕ 12.7)

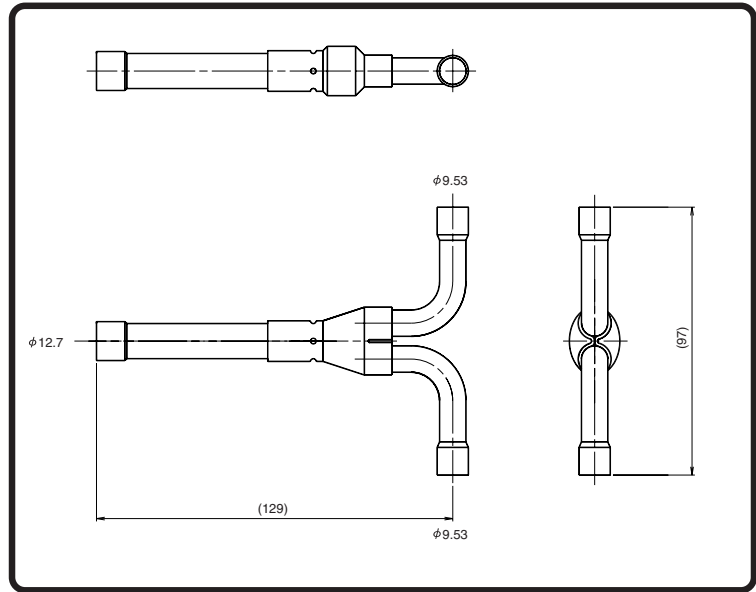

Separation tube (ϕ 19.05)

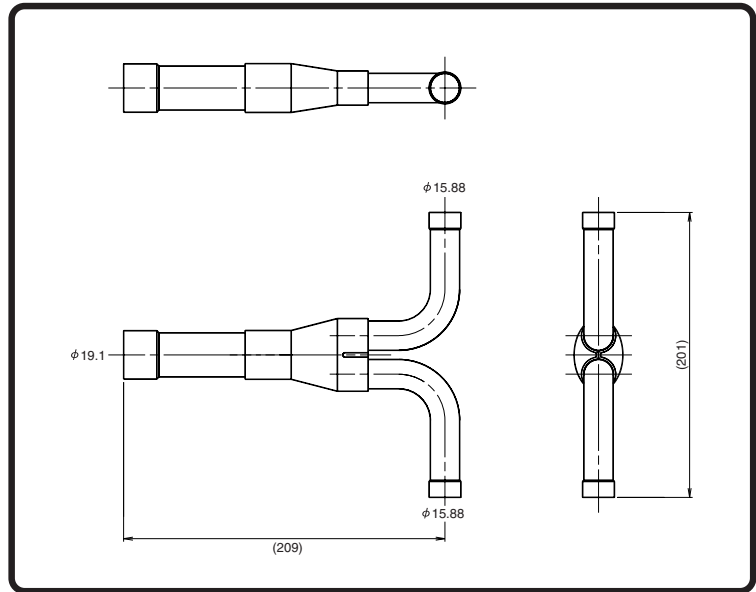

Separation tube (ϕ 28.6)

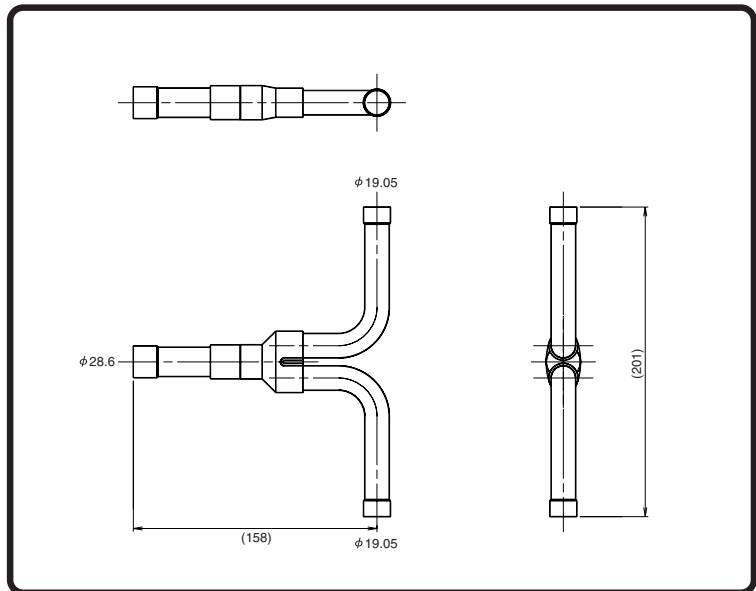

5 - 2. RECOMMENDED SHAPES OF EACH DUCT

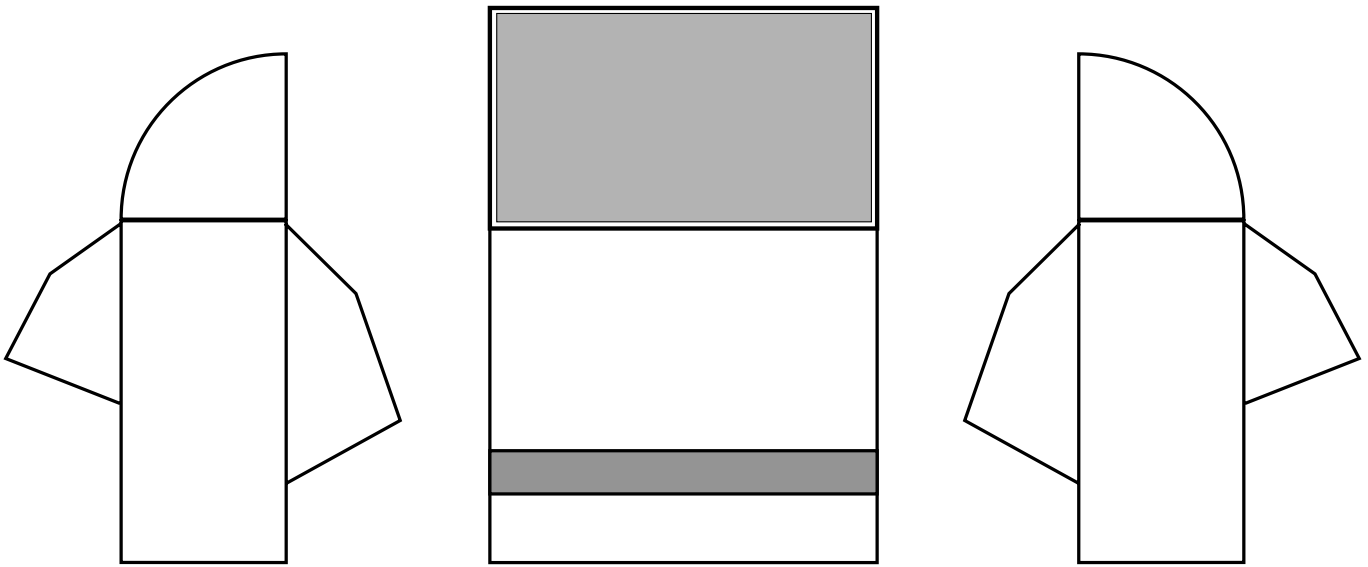

Fig.1 Overall view

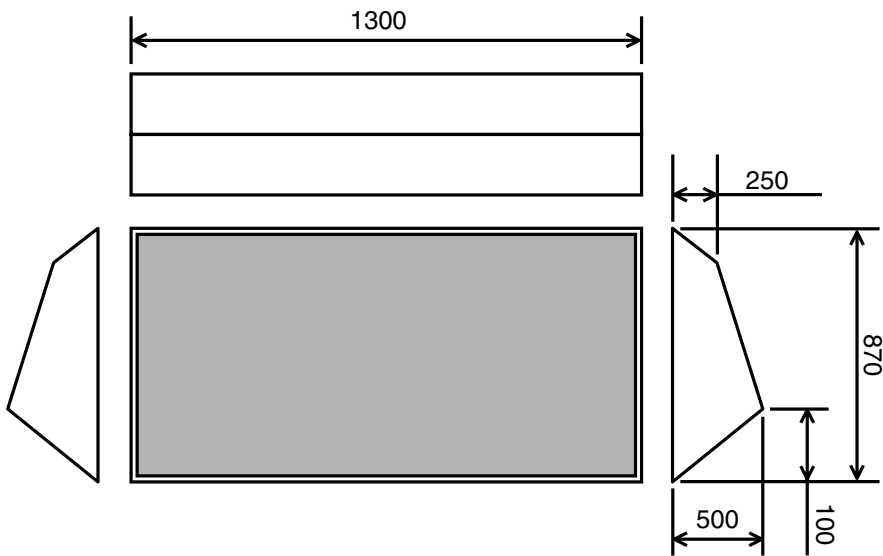

Fig.2 Outdoor unit rear side duct

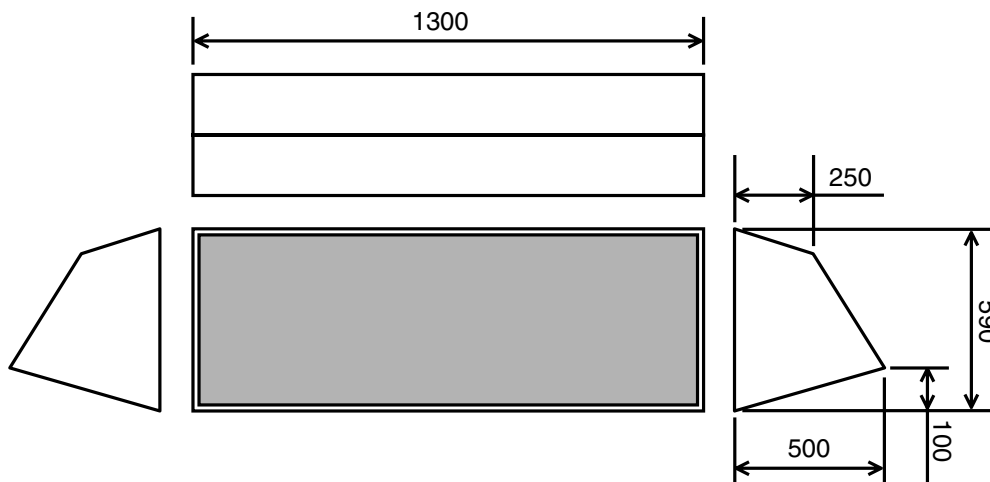

Fig.3 Outdoor unit front side duct

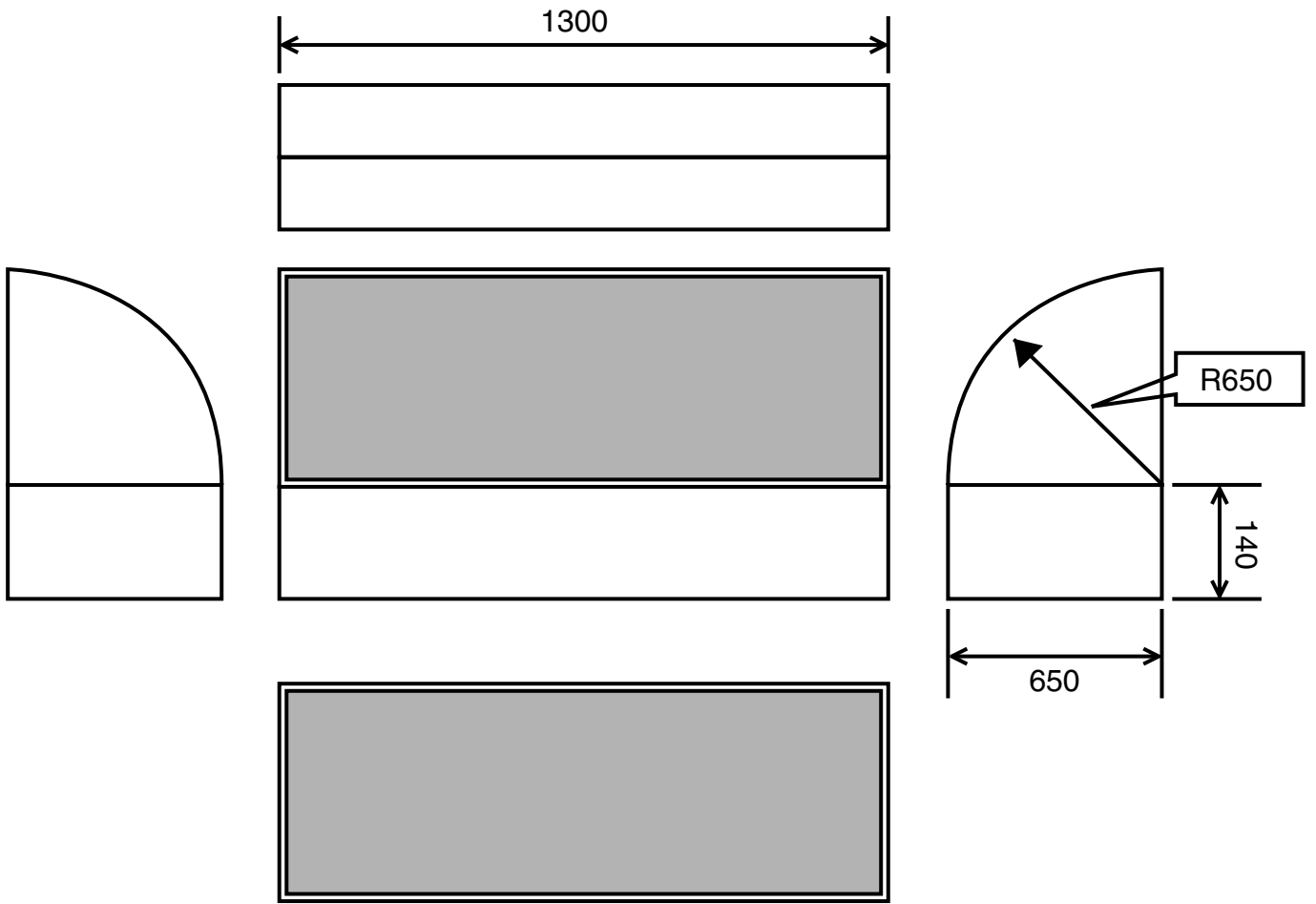
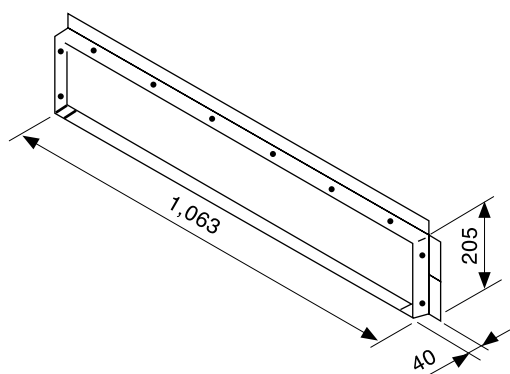

Fig.4 Outdoor unit upper part duct

(Unit : mm)

● SQUARE FLANGE BASE
Model : UTD-SF045



● ROUND FLANGE (OUTLET)
Model : UTD-RF204

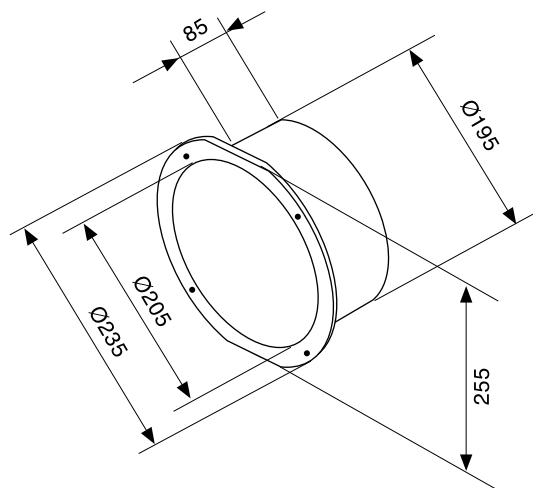

● OUTLET CHAMBER
Model : UTD-BC200

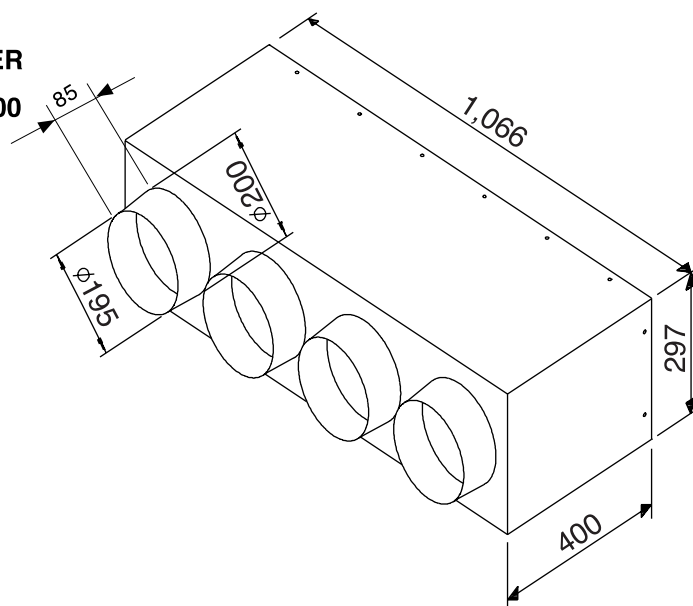

6. MODEL DESIGNATION

6 - 1. OUTDOOR UNIT / INDOOR UNIT

• OUTDOOR UNIT

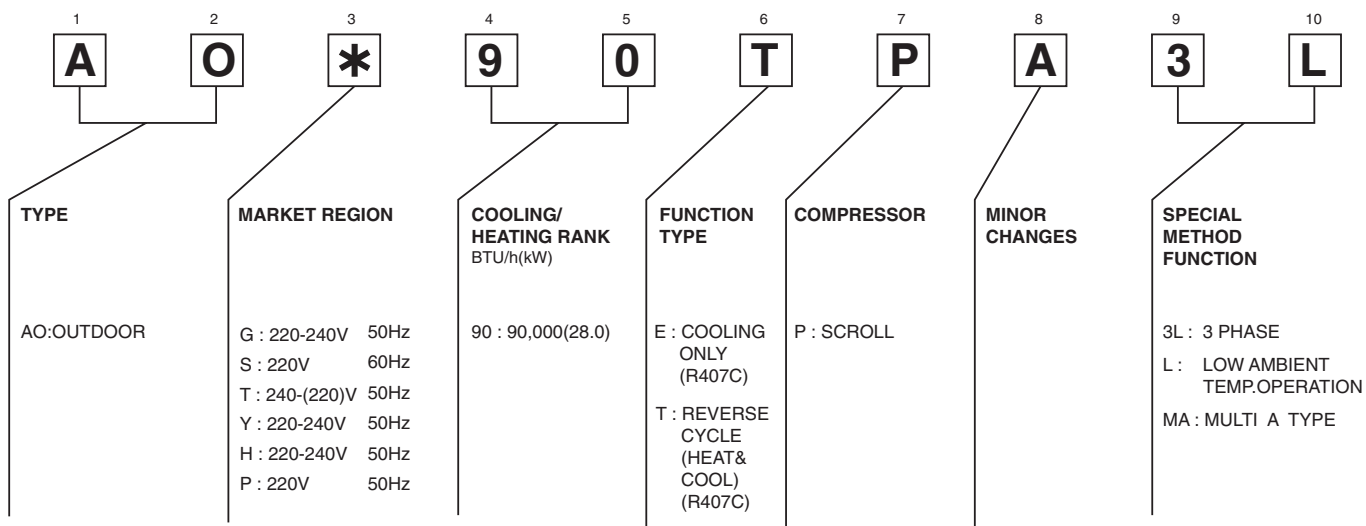

• INDOOR UNIT

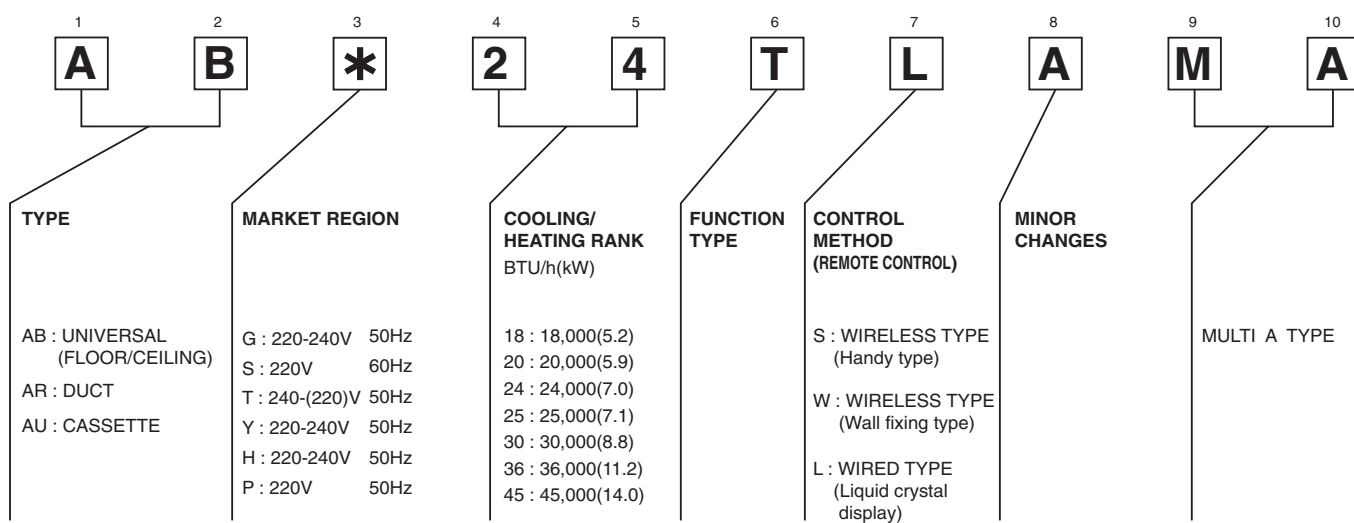

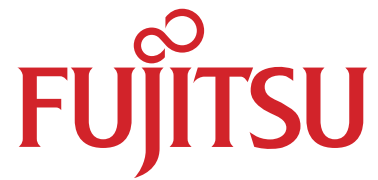

FUJITSU GENERAL LIMITED

1116, Suenaga, Takatsu-ku, Kawasaki 213-8502, Japan