



## **2 . DUCT TYPE**

**AR\* 7 - 9FUAB, AR\* 12 - 18FUAD**

**AR\* 7 - 9UUAB, AR\* 12 - 18UUAD**

## 2-1. FEATURE

### ■ MODELS :

- AR\*7FUAB / AO\*7FSAJ
- AR\*9FUAB / AO\*9FSAJ
- AR\*12FUAD / AO\*12FSAJ
- AR\*14FUAD / AO\*14FSDJ
- AR\*18FUAD / AO\*18FNDK , AO\*18FNDN
- AR\*7UUAB / AO\*7USAJL
- AR\*9UUAB / AO\*9USAJL
- AR\*12UUAD / AO\*12USAJL
- AR\*14UUAD / AO\*14USDJL
- AR\*18UUAD / AO\*18UNDKL , AO\*18UNDNL



### ■ FEATURES

#### ● Universal design indoor unit

Since vertical and horizontal installation is possible, and the intake direction can also be selected from two directions, flexible installation is possible.

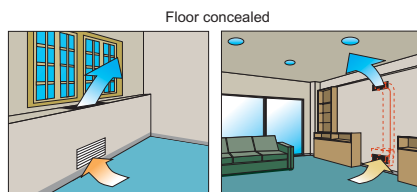
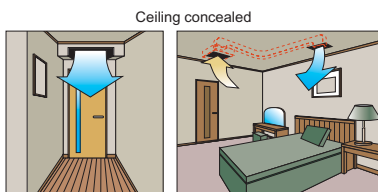

#### ● Thin and compact indoor unit

## 2-2. REMOTE CONTROLLER

### 2-2-1. WIRED REMOTE CONTROLLER

DUCT TYPE  
AR7 - AR18K

#### FEATURES

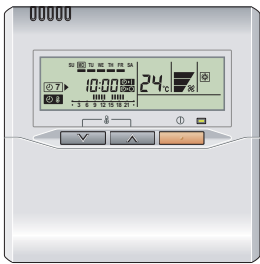

- \* Various timer setup (ON / OFF / WEEKLY) are possible.
- \* Equipped with weekly timer as standard function.  
(2 times Start / Stop per day for a week)
- \* When setting up a timer, operation mode and a temperature setup can be changed.
- \* When a failure occurs, the error code is displayed. (Maximum of 16)
- \* Error indication. (A maximum of 16 error histories are memorizable.)
- \* Up to 16 indoor units can be simultaneously controlled.
- \* Anti freeze and energy saving operation are possible.
- \* Easy installation with a slim shape with no boldge in the back.
- \* The room temperature can be controlled by being detected the temperature accurately with built-in thermo sensor.

DUCT TYPE  
AR7 - AR18K

#### High performance and compact size

Three functions are combined in one unit.



#### Built-in timers

Weekly timer	Setback timer
<p>Possible to set ON/OFF time to operate twice each day of the week.</p> <p>Easy-to-understand time bar display</p> <p>Screen after setup</p> <p>Setup screen example (Set to Wednesday: 8:00 to 20:00.)</p>	<p>Possible to set temperature for two time spans and for each day of the week.</p> <p>Setup screen example (Set from Sunday to Saturday: 12:00 to 15:00, 28 °C.)</p>
At "Weekly timer" + "Set back timer" setup	

#### Easy-to-understand operation

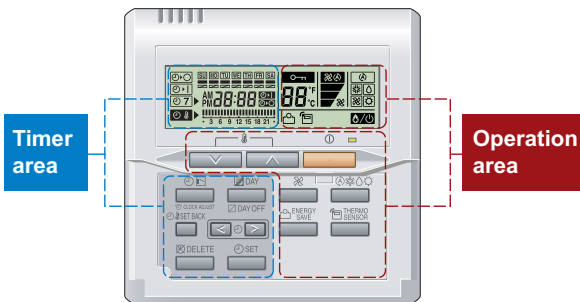

#### [ Variable timer control ]

The operation/display sections are zoned according to time and operation, enabling variable programming to match application.

#### Simple installation

Components are compatible with standard switch boxes. Flat back construction allows equipment to be installed wherever it is needed.

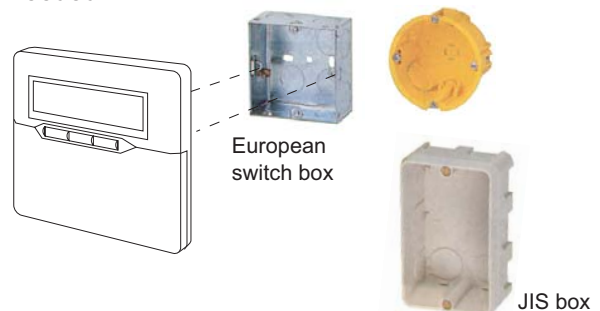

## FUNCTIONS

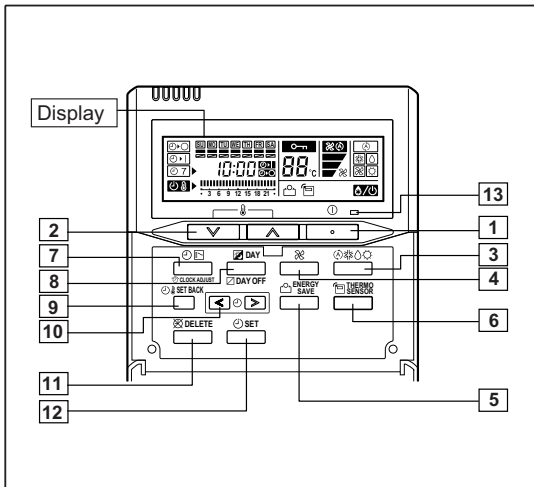

Display panel

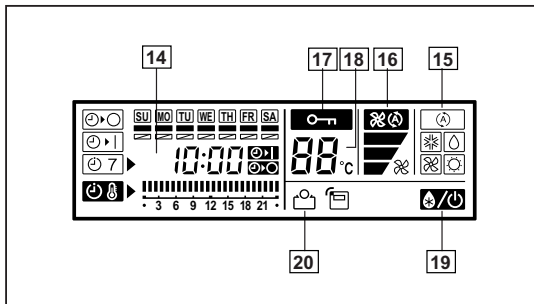

- 1 START/STOP button  
Pressed to start and stop operation.
- 2 Set temperature button  
Selects the setting temperature.
- 3 Master control button  
Selects the operating mode(AUTO, HEAT, FAN, COOL, DRY).
- 4 Fan control button  
Selects the fan speed (AUTO, LOW, MED, HIGH).
- 5 Energy save button  
Turns the energy efficient mode on and off.
- 6 Thermo sensor
- 7 Timer mode (CLOCK ADJUST) button  
Selects the timer mode (OFF TIMER, ON TIMER, WEEKLY TIMER)  
Set the current time.
- 8 Day (DAY OFF) button  
Temporarily cancels of one day timer.
- 9 Set back button  
pressed select the set back timer.
- 10 Set time button  
Pessed to select the set back timer.
- 11 Delete button  
The schedule of a weekly timer is deleted.
- 12 Set button  
Sets the date, hour, minute and on-off time.
- 13 Operation lamp  
Lights during operation and when the timer is on.
- 14 Timer and clock display
- 15 Operation mode display
- 16 Fan speed display
- 17 Central control display
- 18 Temperature display
- 19 Stand by display  
Indicates during the oil recovery and defrosting operation.
- 20 Energy save display

## DIMENSION

[ Unit : mm ]

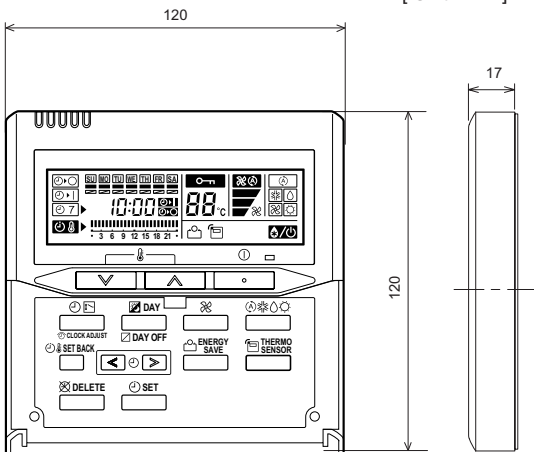

Front View

## SPECIFICATION

SIZE (H x W x D mm)	120 x 120 x 17
WEIGHT (g)	160
CABLE LENGTH (m)	10
POWER (V)	12

## 2-3. SPECIFICATIONS

 DUCT TYPE  
AR7 - AR18K

 DUCT TYPE  
AR7 - AR18K

TYPE			DUCTED MODELS						
			COOLING ONLY TYPE						
MODEL NAME	INDOOR		AR*7FUAB	AR*9FUAB	AR*12FUAD	AR*14FUAD	AR*18FUAD		
	OUTDOOR		AO*7FSAJ	AO*9FSAJ	AO*12FSAJ	AO*14FSDJ	AO*18FNDK		
POWER SOURCE			230V ~ 50Hz						
EUROPEAN ENERGY LABEL			COOLING	C	C	C	B	D	
CAPACITY	COOLING	RATED	kW	2.15	2.80	3.50	4.20	5.40	
			BTU/h	7300	9500	11900	14300	18400	
	HEATING	RATED	kW	-	-	-	-	-	
			BTU/h	-	-	-	-	-	
INPUT POWER	COOLING	RATED	kW	0.76	0.99	1.24	1.39	2.03	
	HEATING	RATED	kW	-	-	-	-	-	
CURRENT	COOLING	RATED	A	3.7	4.6	5.5	6.3	9.0	
	HEATING	RATED	A	-	-	-	-	-	
STARTING CURRENT			A	19.5	21	30	31	39	
EER			COOLING	kW/kW	2.83	2.83	2.82	3.02	2.66
COP			HEATING		-	-	-	-	
MOISTURE REMOVAL			l/h (pints/h)	0.8(1.7)	1.0(2.1)	1.2(3.2)	1.5(3.2)	1.6(3.4)	
AIR CIRCULATION	INDOOR	High	m <sup>3</sup> /h	340	420	500	640	1000	
		Med		320	390	450	560	900	
		Low		300	360	400	480	760	
	OUTDOOR				1600	1600	1600	1600	3200
RECOMMENDED STATIC PRESSURE			Pa	0(0-20,20-40)	0(0-20,20-40)	0(0-20,20-40)	0(0-20,20-40)	0(0to70)	
FAN TYPE x Qty			INDOOR	Sirocco x 1	Sirocco x 1	Sirocco x 2	Sirocco x 2	Sirocco x 2	
			OUTDOOR	Propeller x 1	Propeller x 1	Propeller x 1	Propeller x 1	Propeller x 1	
FAN MOTOR OUTPUT			INDOOR	W	13	13	45	45	45
			OUTDOOR		22	22	22	22	65
NOISE LEVEL (SOUND PRESSURE)	INDOOR	High	dB(A)	31.00	35.00	29.00	34.00	43.00	
		Med		28.00	33.00	28.00	32.00	40.00	
		Low		26.00	31.00	27.00	30.00	36.00	
COOL/HEAT			OUTDOOR		48.00	48.00	49.00	48.00	52.00
COMPRESSOR			TYPE	ROTARY					
			OUTPUT	700	900	1075	1150	1500	
			STARTING METHOD	Permanent Starting Condenser					
HEAT EXCHANGER TYPE	INDOOR	Coil	Copper tube						
		fin	Aluminum						
		Rows x Stages x Fin Pitch	mm	2x14x1.30	2x14x1.30	2x14x1.30	2x14x1.30	2x14x1.30	
	Coil Dimensions	mm	294x410x26.6	294x410x26.6	294x700x26.6	294x700x26.6	294x700x26.6		
	OUTDOOR	Coil	Copper tube						
		fin	Aluminum						
Rows x Stages x Fin Pitch		mm	1x24x1.45	1x24x1.45	2x24x1.45	2x24x1.45	1x30x1.30		
			Coil Dimensions	mm	504x770x18.19	504x770x18.19	504x658x36.38	504x658x36.38	630x905x18.19
SAFETY DEVICES			INDOOR	Fan motor thermal protector, Fuse					
			OUTDOOR	Fan motor thermal protector, Fuse					
CASING COLOR			INDOOR	Hot-dipped galvanized steel sheet					
			OUTDOOR	Beige(10YR7.5/1.0NN)					
DIMENSIONS H * W * D	INDOOR	NET	mm	217 x 663 x 595	217 x 663 x 595	217 x 953 x 595	217 x 953 x 595	217 x 953 x 595	
		OUTDOOR		530 x 750 x 250	530 x 750 x 250	530 x 750 x 250	530 x 750 x 250	650 x 830 x 320	
	GROSS	INDOOR		324 x 785 x 686	324 x 785 x 686	324 x 785 x 686	324 x 785 x 686	324 x 785 x 686	
		OUTDOOR		609 x 882 x 339	609 x 882 x 339	609 x 882 x 339	609 x 882 x 339	743 x 984 x 413	
WEIGHT	INDOOR	NET / GROSS	kg(lbs)	18/22	18/22	25/29	25/29	25/29	
	OUTDOOR			27/29	27/29	34/36	35/37	52/56	
PIPE	CONNECTION METHOD			FLARE					
	SIZE	LIQUID	mm	6.35 (1/4 inc.)	6.35(1/4 inc.)	6.35(1/4 inc.)	6.35(1/4 inc.)	6.35(1/4 inc.)	
		GAS		9.52(3/8 inc.)	9.52(3/8 inc.)	9.52(3/8 inc.)	12.7(1/2 inc.)	15.88(5/8 inc.)	
	MAX LENGTH			m	15	15	15	15	20
MAX HEIGHT			m	8	8	8	8	8	
REFRIGERANT			TYPE	R410A					
			CHARGE	kg	0.55	0.60	0.80	0.90	0.90
REFRIGERANT OIL			TYPE	POE					
OPERATION(OUTDOOR)			COOLING	21 to 43					
			HEATING						
REMOTE CONTROLLER			WIRED(AR-3TA1)						
DRAIN PIPE			MATERIAL	ABS					
			SIZE	mm	Outer diameter 26.0mm / Inner diameter 21.5mm				
OPTIONS			INDOOR	Simple Wired Remocon(Fujitsu:UTB-YPB,General:UTB-GPB)					
			OUTDOOR						

Note: Specifications are based on the following conditions.  
 Cooling: Indoor temperature of 27°CDB / 19°CWB, and outdoor temperature of 35°CDB/24°CWB.  
 Heating: Indoor temperature of 20°CDB / 15°CWB, and outdoor temperature of 7°CDB/6°CWB.  
 Standard static pressure : 0 Pa.  
 Pipe length : 7.5 m, Height difference : 0 m.(Outdoor unit - Indoor unit)

TYPE				DUCTED MODELS				
				REVERSE CYCLE TYPE				
MODEL NAME		INDOOR		AR * 7UJAB	AR * 9UJAB	AR * 12UJAD	AR * 14UJAD	AR * 18UJAD
		OUTDOOR		AO * 7USAJL	AO * 9USAJL	AO * 12USAJL	AO * 14USDJL	AO * 18UNDKJL
POWER SOURCE				230V~ 50Hz				
CAPACITY	COOLING	RATED	kW	2.15	2.70	3.50	4.00	5.40
			BTU/h	7300	9200	11900	13700	18400
	HEATING	RATED	kW	2.45	3.10	4.00	4.70	6.00
			BTU/h	8400	10600	13600	16000	20500
INPUT POWER	COOLING	RATED	kW	0.76	0.96	1.24	1.42	1.92
			HEATING	RATED	0.76	0.96	1.21	1.35
CURRENT	COOLING	RATED	A	3.60	4.40	5.50	6.3	8.8
			HEATING	RATED	3.60	4.50	5.40	6.0
STARTING CURRENT			A	19.5	21	30	31	39
EER		COOLING	kW/kW	2.83	2.81	2.82	2.82	2.81
COP		HEATING		3.22	3.23	3.31	3.48	3.21
MOISTURE REMOVAL			lh (pints/h)	0.8(1.7)	1.0(2.1)	1.2(3.2)	1.5(3.2)	1.6(3.4)
AIR CIRCULATION	INDOOR	High	m <sup>3</sup> /h	340	420	500	640	1000
		Med		320	390	450	560	900
		Low		300	360	400	480	760
	OUTDOOR		1600	1600	1600	1600	3200	
RECOMMENDED STATIC PRESSURE			Pa	0(0-20,20-40)	0(0-20,20-40)	0(0-20,20-40)	0(0-20,20-40)	0(0to70)
FAN TYPE x Q'ty		INDOOR		Sirocco x 1	Sirocco x 1	Sirocco x 2	Sirocco x 2	Sirocco x 2
		OUTDOOR		Propeller x 1	Propeller x 1	Propeller x 1	Propeller x 1	Propeller x 1
FAN MOTOR OUTPUT		INDOOR	W	13	13	45	45	45
		OUTDOOR		22	22	22	22	65
NOISE LEVEL (SOUND PRESSURE)	INDOOR	High	dB(A)	31.0/31.0	35.0/36.0	29.0/30.0	34.0/34.0	43.0/43.0
		Med		28.0/28.0	33.0/35.0	28.0/29.0	32.0/32.0	40.0/40.0
		Low		26.0/26.0	31.0/34.0	27.0/28.0	30.0/30.0	36.0/36.0
COOL/HEAT		OUTDOOR		48.0/48.0	48.0/50.0	49.0/50.0	49.0/50.0	52.0/53.0
COMPRESSOR		TYPE		ROTARY				
		OUTPUT		700	900	1075	1150	1500
		STARTING METHOD		Permanent Starting Condenser				
HEAT EXCHANGER TYPE	INDOOR	Coil		Copper tube				
		Fin		Aluminum				
		Rows x Stages	mm	2 x 14				
		Fin Pitch	mm	1.30				
	Coil Dimensions	mm	294 x 410 x 26.6	294 x 410 x 26.6	294 x 700 x 26.6	294 x 700 x 26.6	294 x 700 x 26.6	
	OUTDOOR	Coil		Copper tube				
		Fin		Aluminum				
		Rows x Stages	mm	1 x 24	2 x 24	2 x 24	2 x 24	2 x 30
Fin Pitch		mm	1.45	1.45	1.45	1.45	1.45	
Coil Dimensions	mm	504 x 770 x 18.19	504 x 658 x 36.38	504 x 658 x 36.38	504 x 658 x 36.38	630 x 901 x 36.38		
SAFETY DEVICES		INDOOR		Fan motor thermal protector,Fuse				
		OUTDOOR		Fan motor thermal protector,Fuse				
CASING COLOR		INDOOR		Hot-dipped galvanized steel sheet				
		OUTDOOR		Beige(10YR7.5/1.0NN)				
DIMENSIONS H x W x D	INDOOR	NET	mm	217 x 663 x 595	217 x 663 x 595	217 x 953 x 595	217 x 953 x 595	217 x 953 x 595
				OUTDOOR	530 x 750 x 250	530 x 750 x 250	530 x 750 x 250	530 x 750 x 250
	INDOOR	GROSS		324 x 785 x 686	324 x 785 x 686	324 x 1075 x 686	324 x 1075 x 686	324 x 1075 x 686
				OUTDOOR	609 x 882 x 339	609 x 882 x 339	609 x 882 x 339	609 x 882 x 339
WEIGHT	INDOOR	NET /	kg	18/22	18/22	25/29	25/29	25/29
	OUTDOOR	GROSS		28/30	30/32	34/36	35/37	52/56
PIPE	CONNECTION METHOD			FLARE				
	SIZE	LIQUID	mm	Φ6.35(1/4 inc.)	Φ6.35(1/4 inc.)	Φ6.35(1/4 inc.)	Φ6.35(1/4 inc.)	Φ6.35(1/4 inc.)
		GAS		Φ9.52(3/8 inc.)	Φ9.52(3/8 inc.)	Φ9.52(3/8 inc.)	Φ12.7(1/2 inc.)	Φ15.88(5/8 inc.)
	MAX LENGTH		m	15	15	15	15	20
MAX HEIGHT		m	8	8	8	8	8	
REFRIGERANT		TYPE		R410A				
		CHARGE	kg	0.65	0.75	0.85	1.00	1.40
REFRIGERANT OIL		TYPE		POE				
OPERATION(OUTDOOR)		COOLING	°C	0 to 43				
		HEATING		-6 to 24				
REMOTE CONTROLLER				WIRED(AR-3TA2)				
DRAIN PIPE		MATERIAL		ABS				
		SIZE	mm	Outer diameter 26.0 Inner diameter 21.5				
OPTIONS		INDOOR		Simple Wired Remocon(Fujitsu:UTB-YPB,General:UTB-GPB)				
		OUTDOOR		-				

Note: Specifications are based on the following conditions.  
Cooling: Indoor temperature of 27°CDB / 19°CWB, and outdoor temperature of 35°CDB/24°CWB.  
Heating: Indoor temperature of 20°CDB / 15°CWB, and outdoor temperature of 7°CDB/6°CWB.  
Standard static pressure : 0 Pa.  
Pipe length : 7.5 m, Height difference : 0 m.(Outdoor unit - Indoor unit)

## 2-4. DIMENSIONS

### 2-4-1. OUTDOOR UNIT

#### MODELS :

AO\*7F , AO\*9F , AO\*12F , AO\*14F  
 AO\*7U , AO\*9U , AO\*12U , AO\*14U

DUCT TYPE  
AR7 - AR18K

DUCT TYPE  
AR7 - AR18K

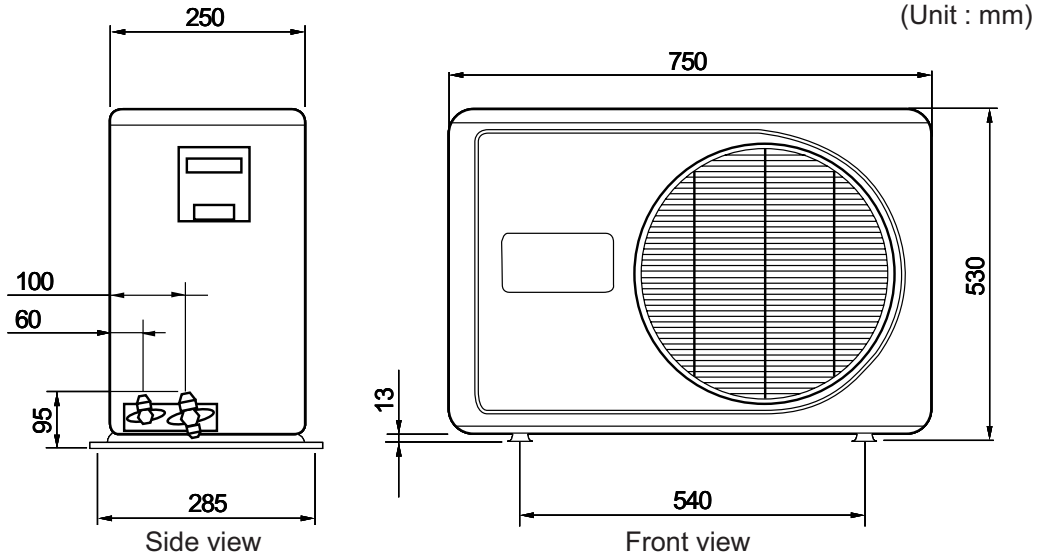

#### MOUNTING POSITION

When there are obstacles at the back or front sides.

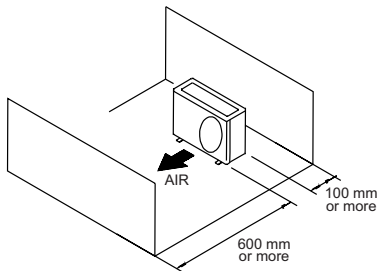

When there are obstacles at the back, side(s), and top.

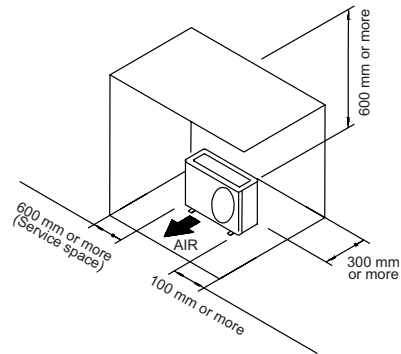

When there are obstacles at the back, side with the installation of more than one unit.

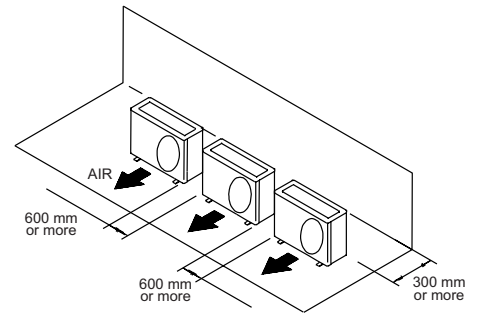

■ MODELS : AO\*18F , AO\*18U

DUCT TYPE  
AR7 - AR18K

DUCT TYPE  
AR7 - AR18K

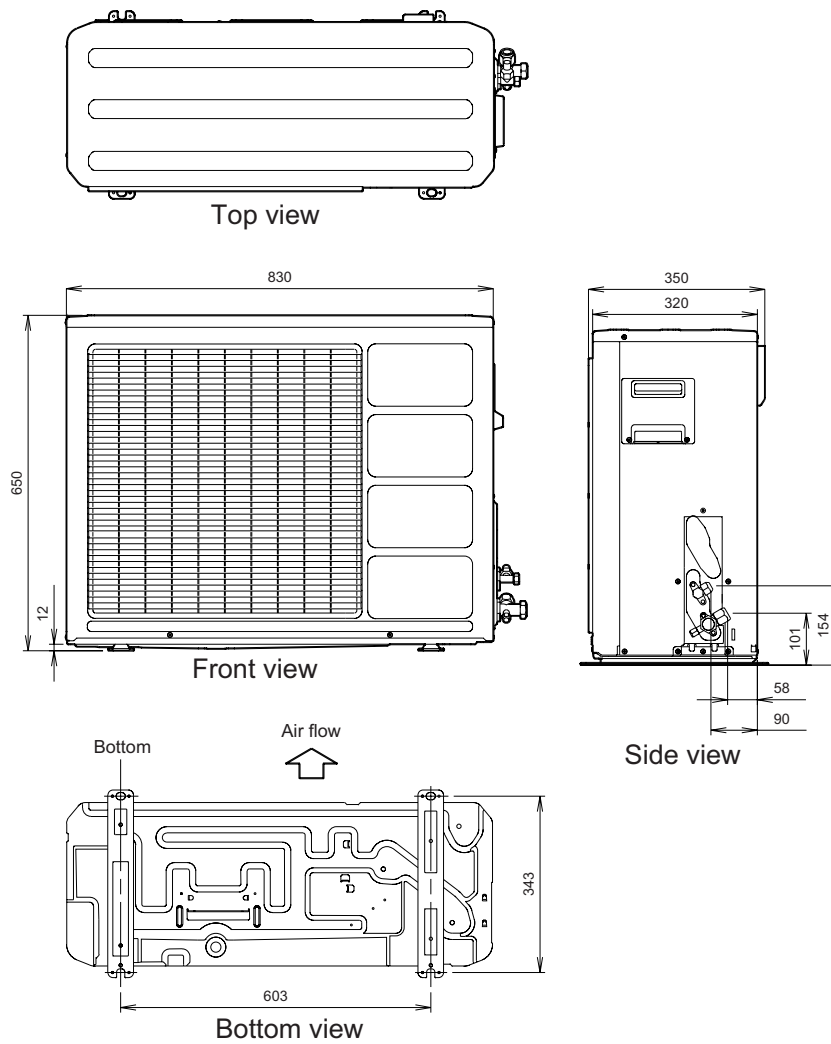

■ MOUNTING POSITION

When there are obstacles at the back or front sides.

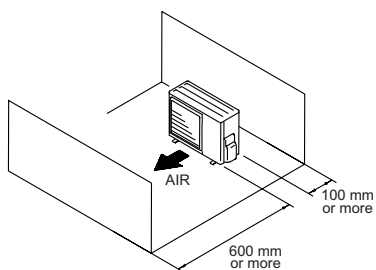

When there are obstacles at the back, side(s), and top.

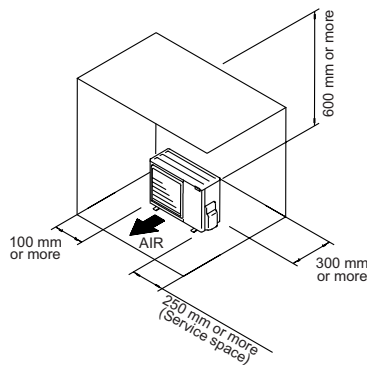

When there are obstacles at the back, side with the installation of more than one unit.

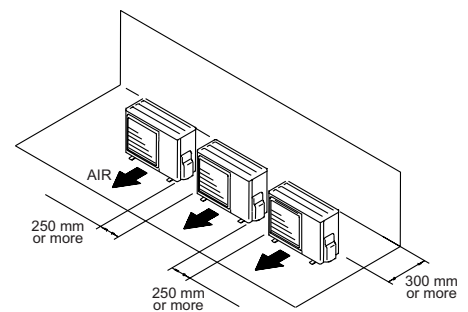



## 2-4-2. INDOOR UNIT

### MODELS :

AR\*7F , AR\*9F , AR\*12F , AR\*14F , AR\*18F

AR\*7U , AR\*9U , AR\*12U , AR\*14U , AR\*18U

DUCT TYPE  
AR7 - AR18K

DUCT TYPE  
AR7 - AR18K

( ) : AR7, AR9 (Unit : mm)

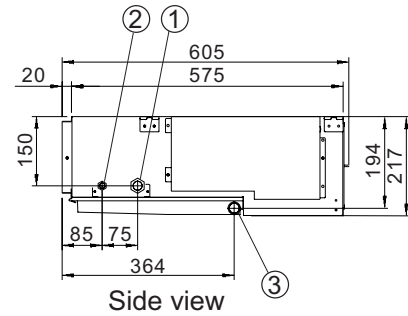
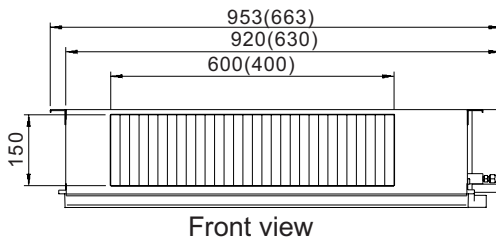
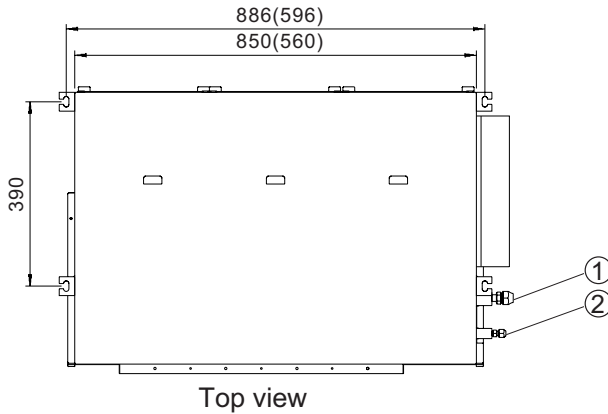
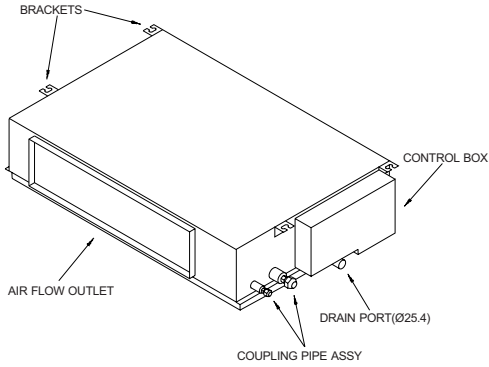

- ① Refrigerant piping flare connection (Gas)
- ② Refrigerant piping flare connection (Liquid)
- ③ Drain piping connection (Drain pipe : I.D. Ø21.5 O.D. Ø26.0)

# ■ MOUNTING POSITION

DUCT TYPE  
AR7 - AR18K

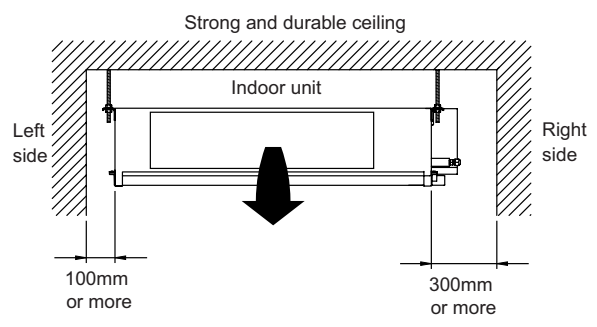
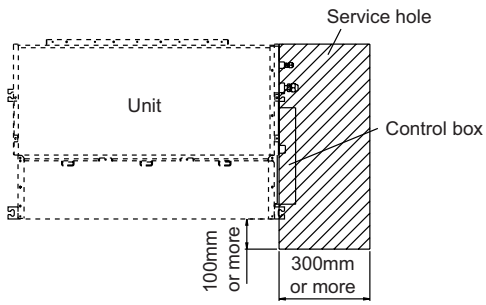

DUCT TYPE  
AR7 - AR18K

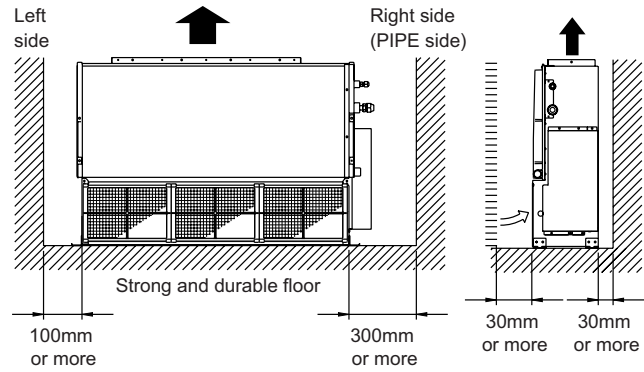

## 2-5. REFRIGERANT CIRCUIT

- MODELS : AR\*7F / AO\*7F  
AR\*9F / AO\*9F

DUCT TYPE  
AR7 - AR18K

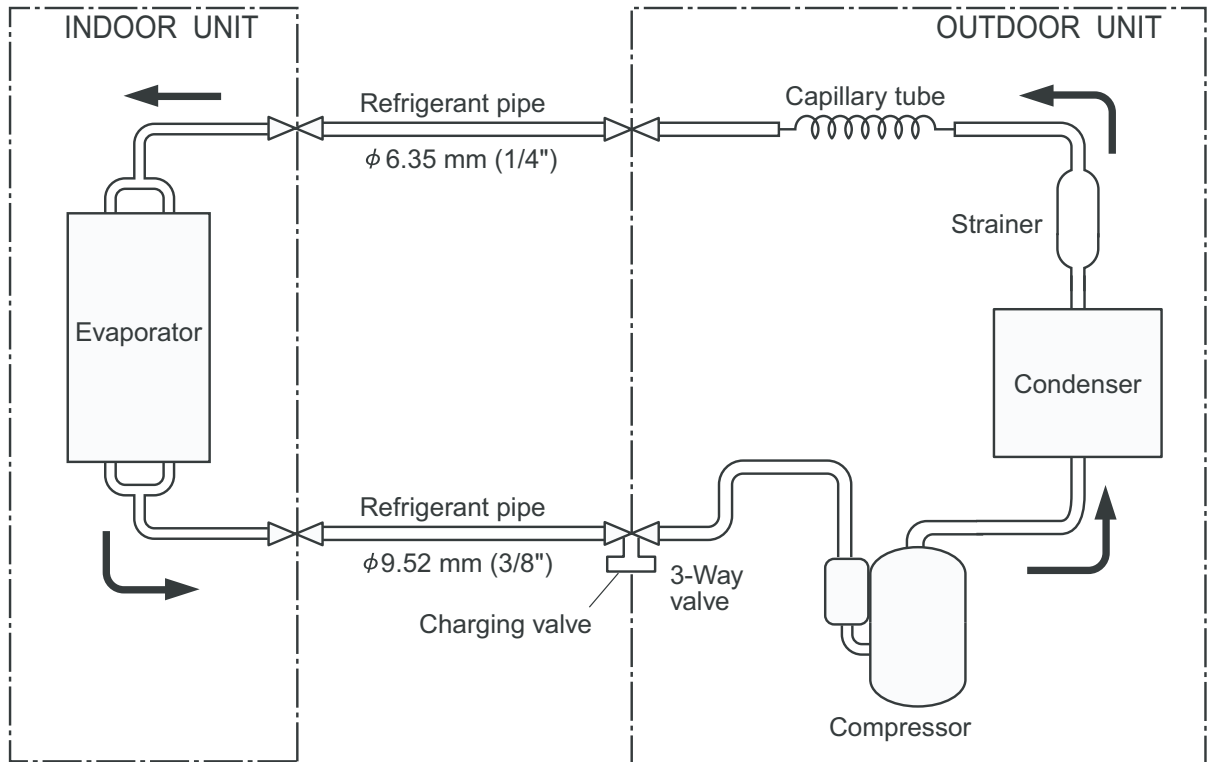

DUCT TYPE  
AR7 - AR18K

- MODELS : AR\*7U / AO\*7U

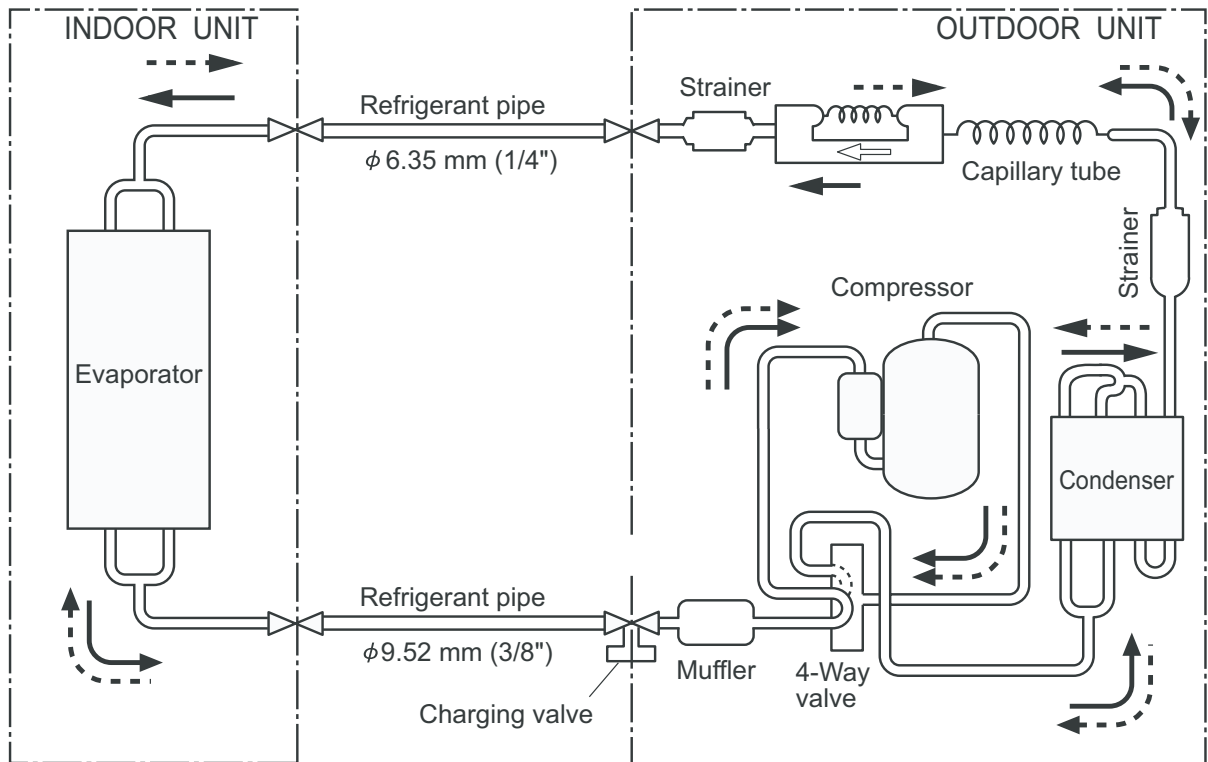

● MODELS : AR\*9U / AO\*9U

DUCT TYPE  
AR7 - AR18K

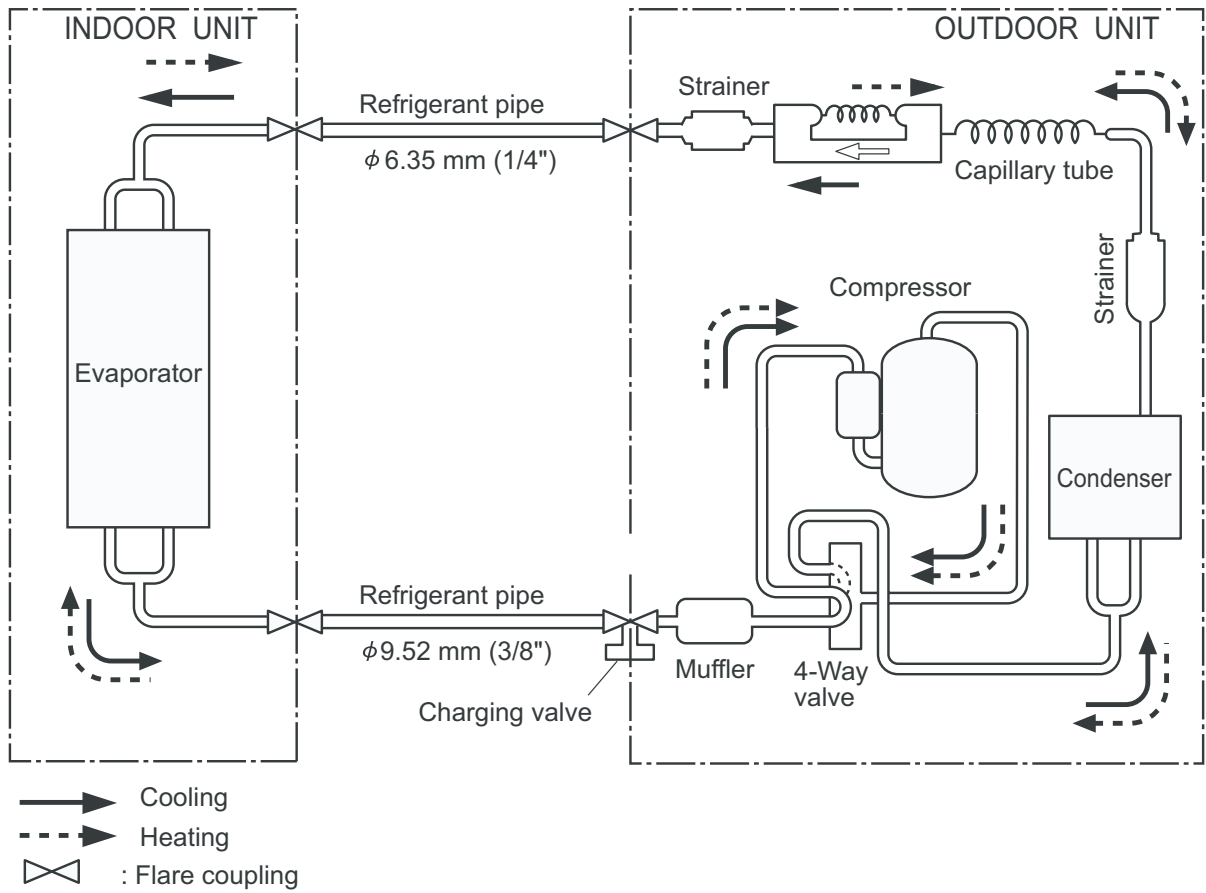

DUCT TYPE  
AR7 - AR18K

● MODELS : AR\*12F / AO\*12F

DUCT TYPE  
AR7 - AR18K

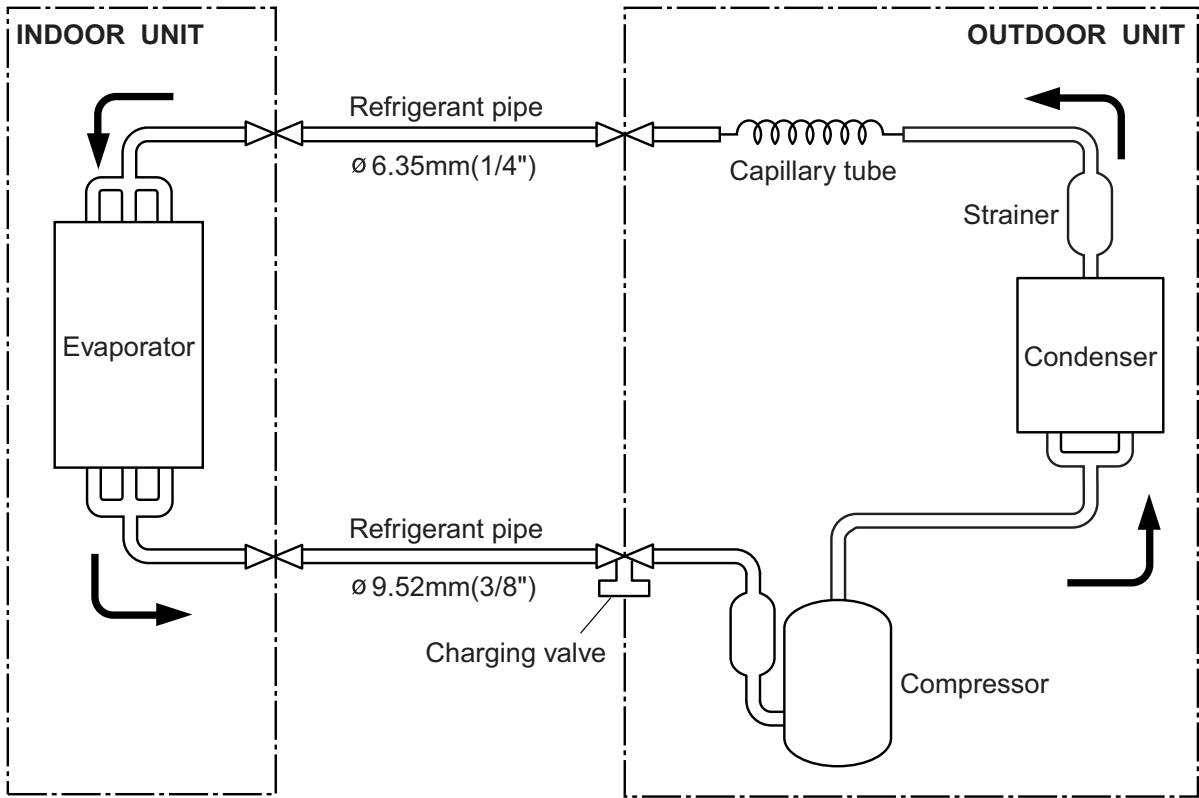

DUCT TYPE  
AR7 - AR18K

● MODELS : AR\*12U / AO\*12U

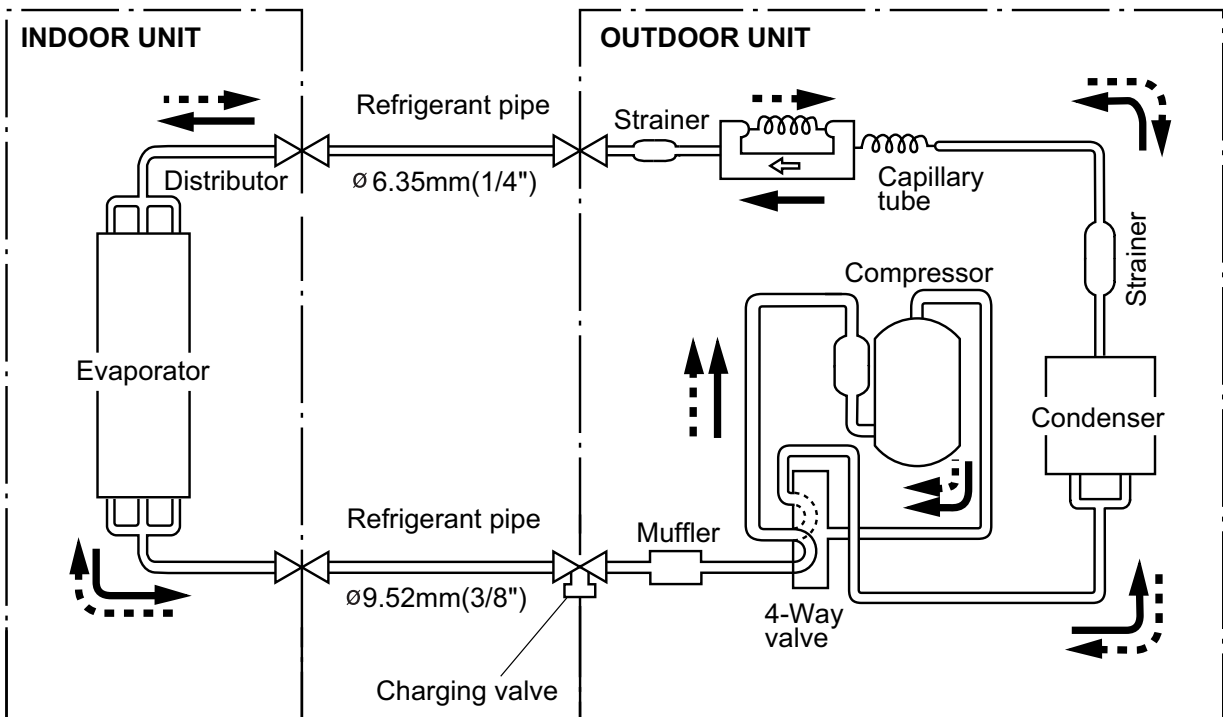

- Cooling
- Heating
- : Flare coupling

● MODELS : AR\*14F / AO\*14F

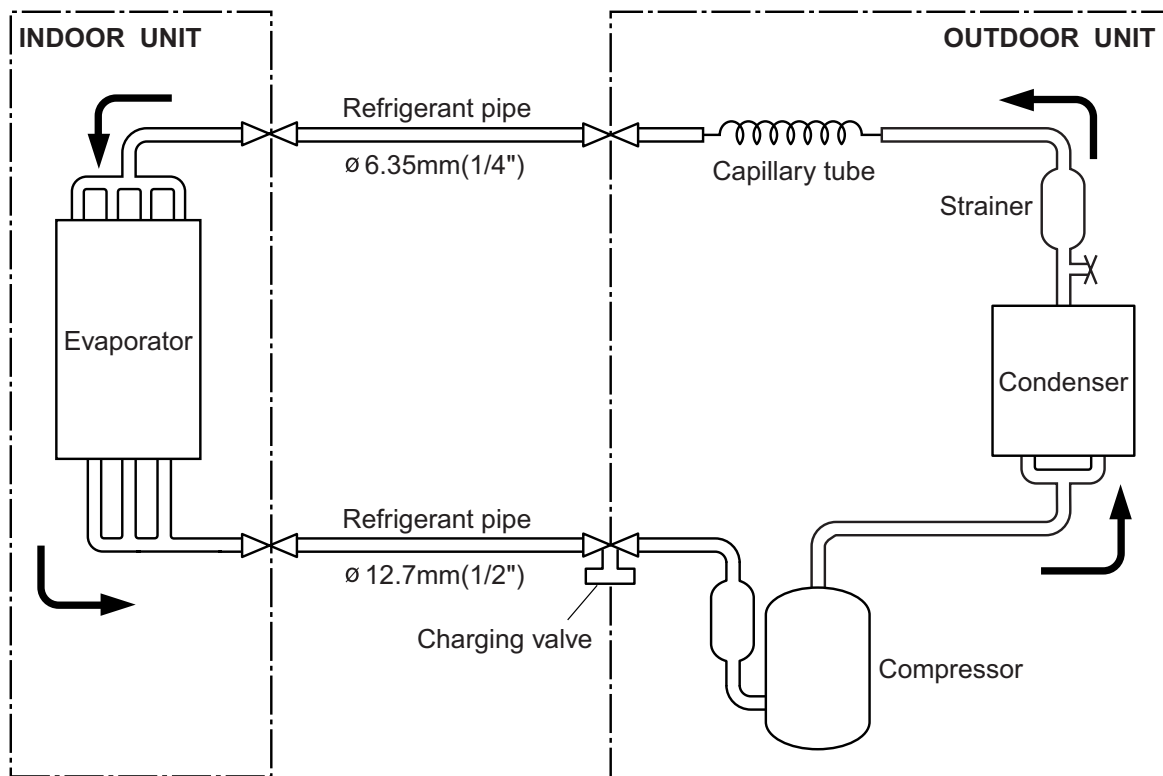

● MODELS : AR\*14U / AO\*14U

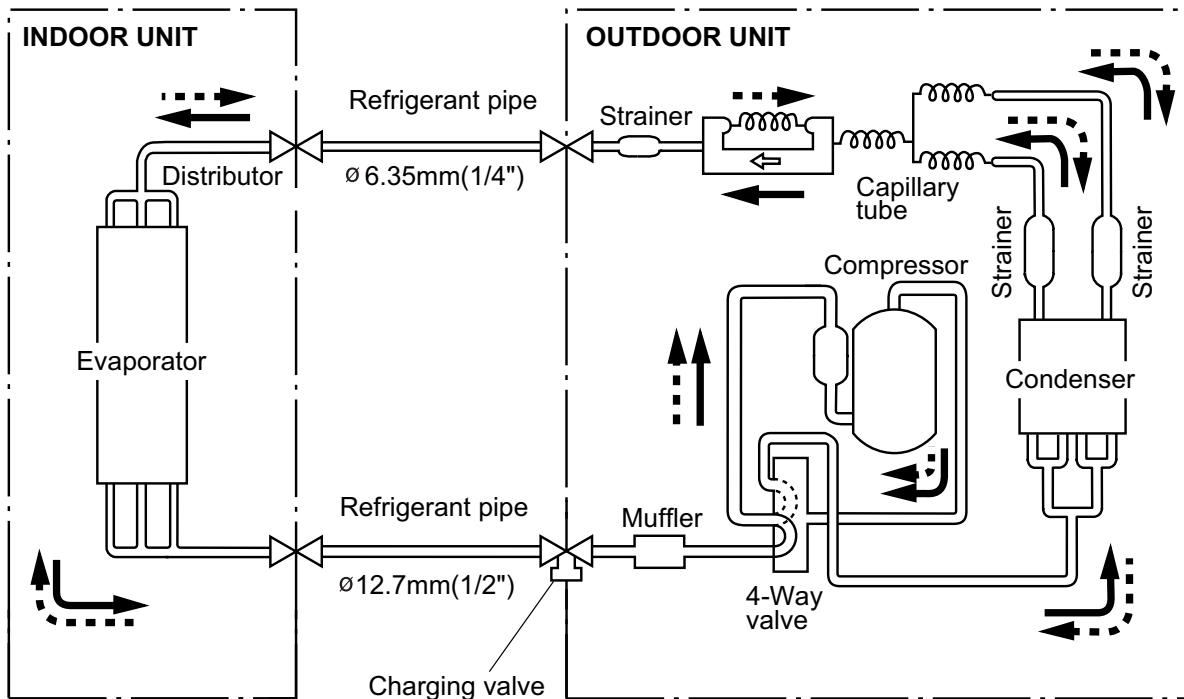

- Cooling
- Heating
- : Flare coupling

DUCT TYPE  
AR7 - AR18K

● MODELS : AR\*18F / AO\*18F

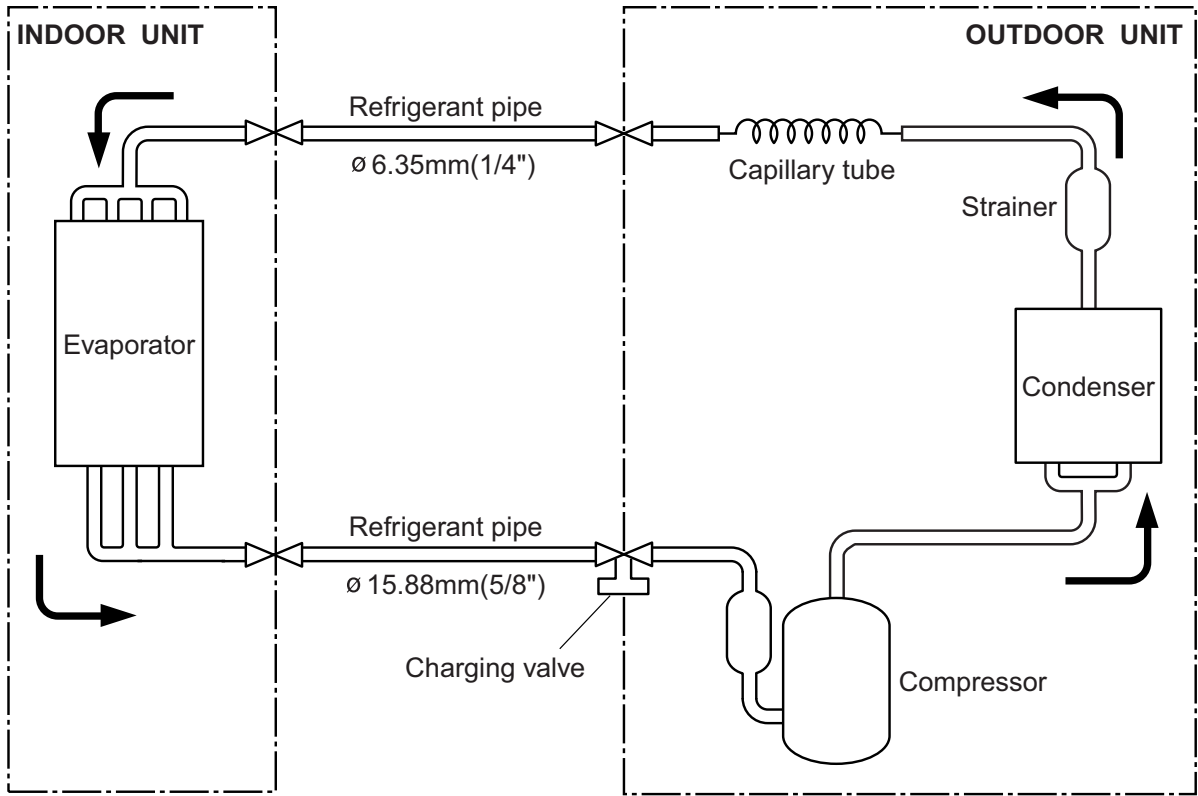

DUCT TYPE  
AR7 - AR18K

● MODELS : AR\*18U / AO\*18U

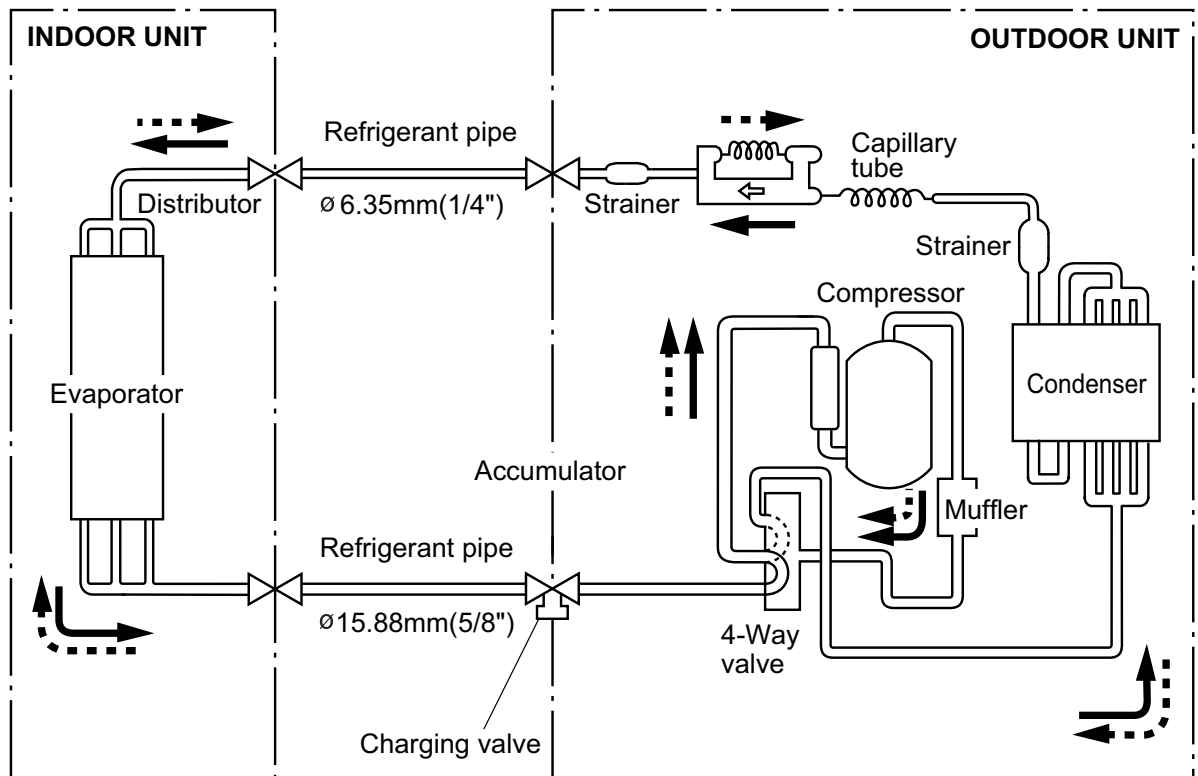

- Cooling
- Heating
- : Flare coupling

## 2-6. WIRING DIAGRAMS

■ MODELS : AR\*7F / AO\*7F  
AR\*9F / AO\*9F

DUCT TYPE  
AR7 - AR18K

DUCT TYPE  
AR7 - AR18K

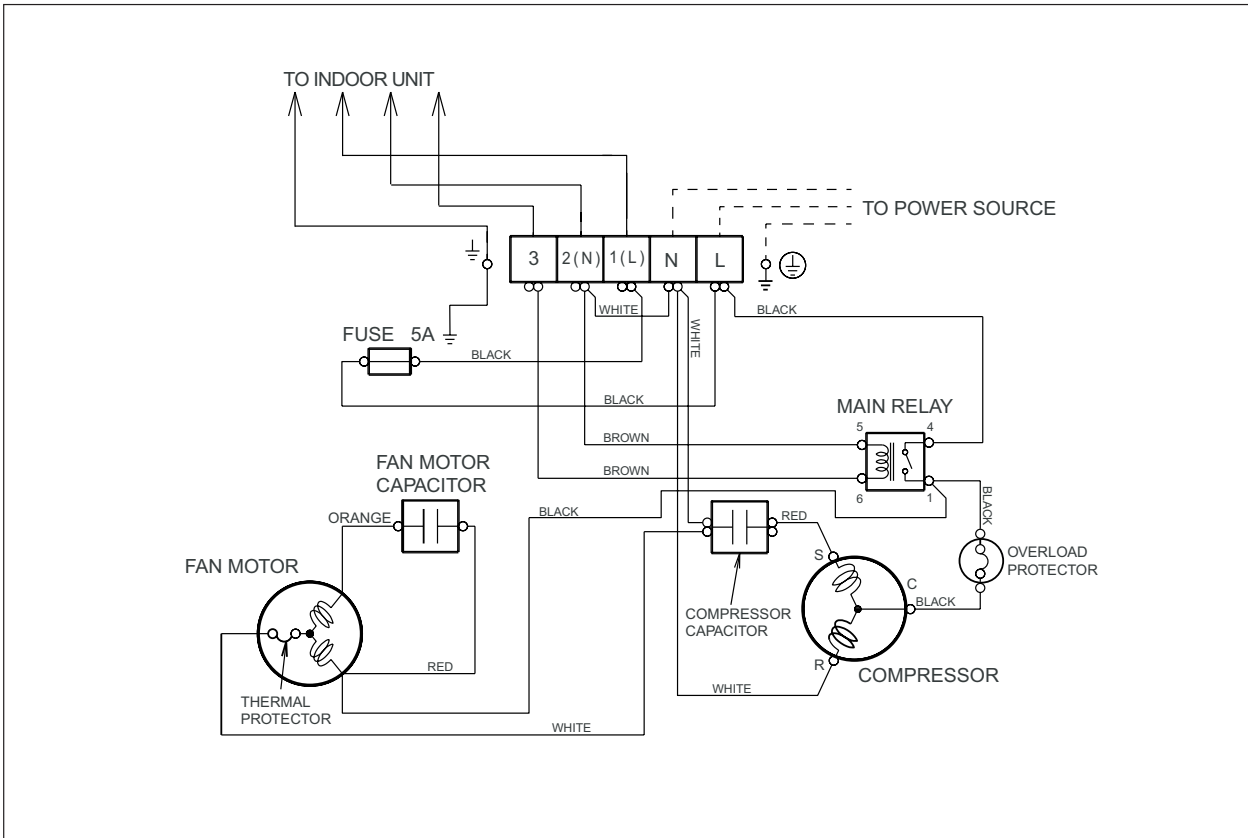
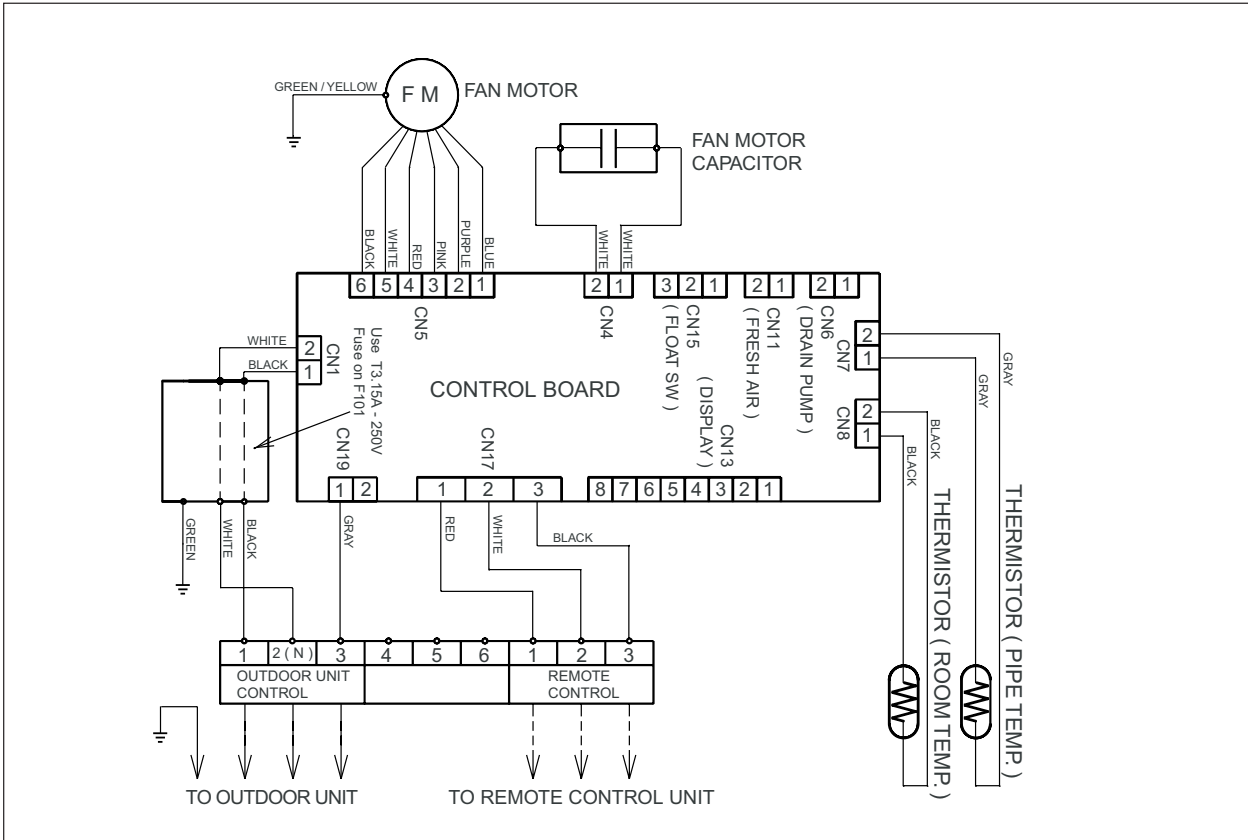



**MODELS : AR\*7U / AO\*7U  
AR\*9U / AO\*9U**

DUCT TYPE  
AR7 - AR18K

DUCT TYPE  
AR7 - AR18K

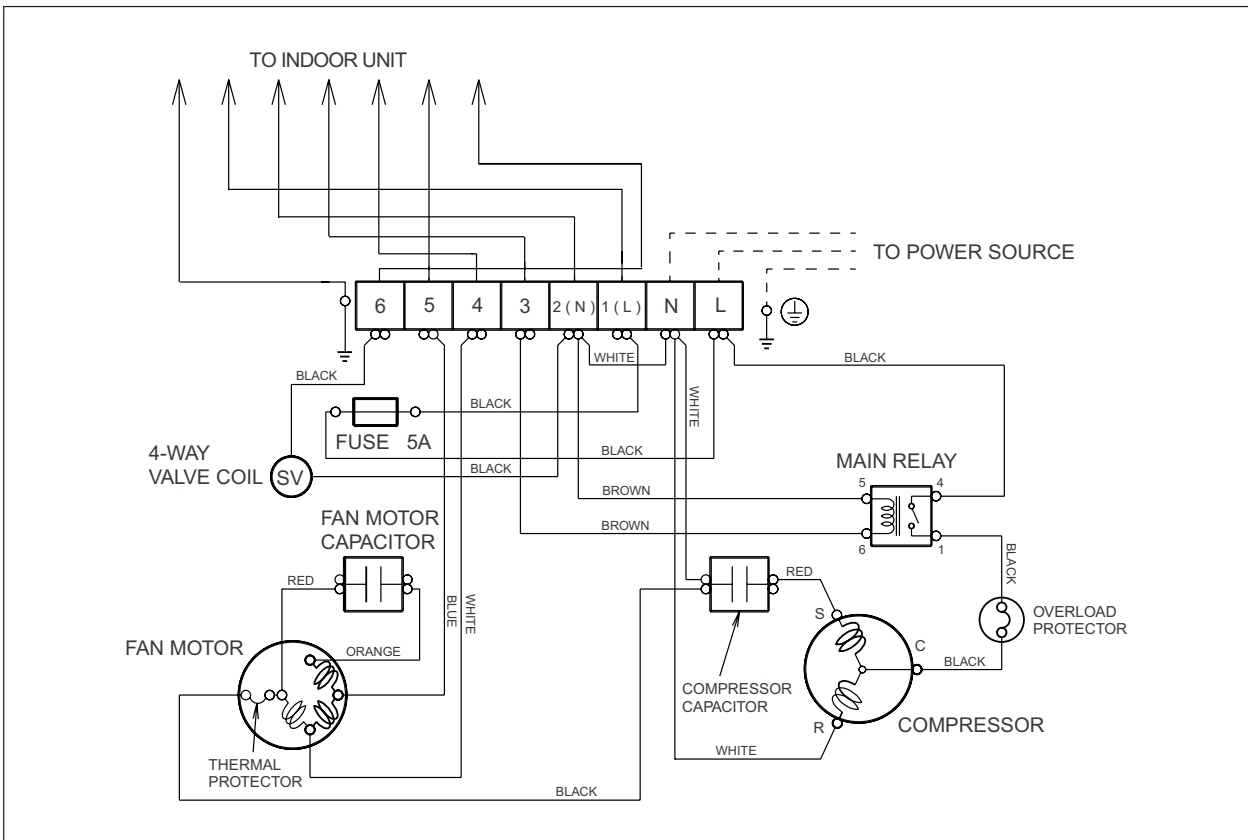
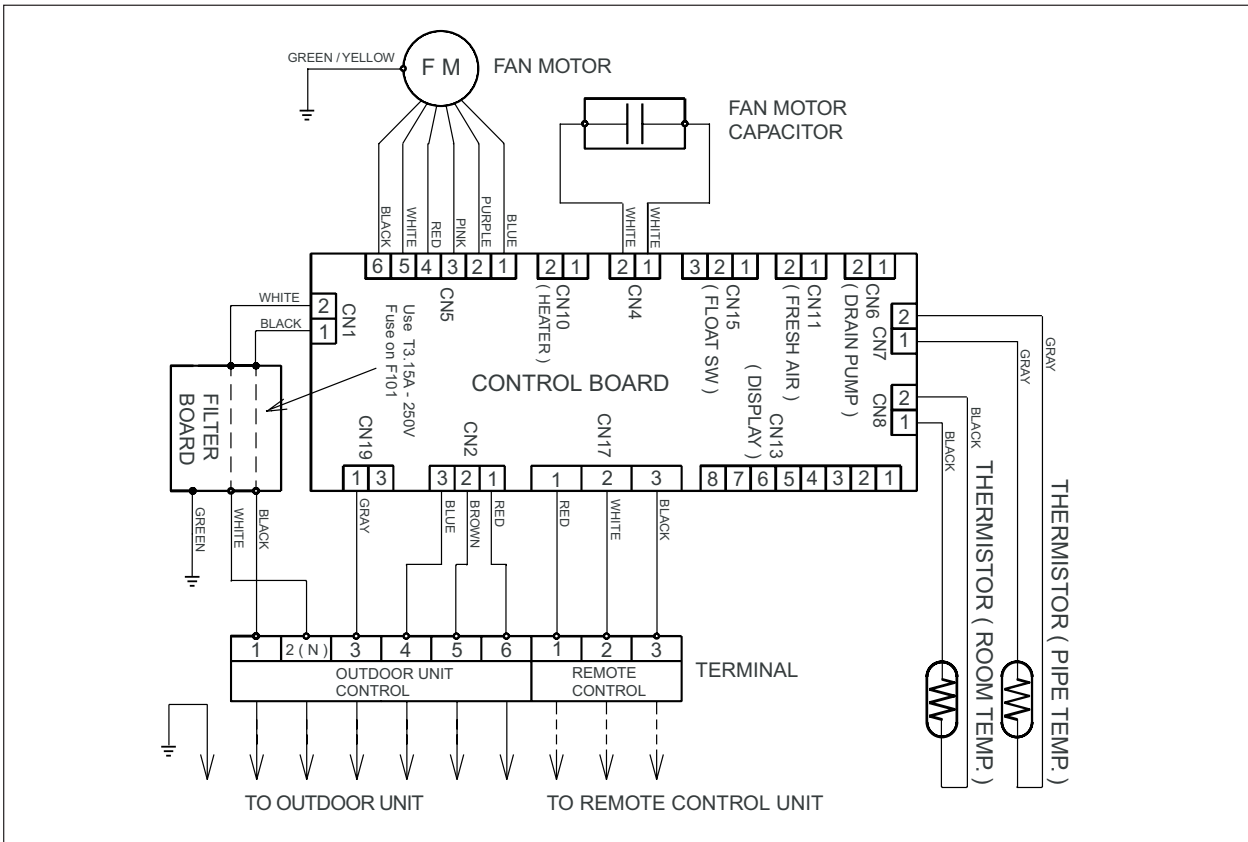

MODELS : AR\*12F / AO\*12F  
AR\*14F / AO\*14F

DUCT TYPE  
AR7 - AR18K

DUCT TYPE  
AR7 - AR18K

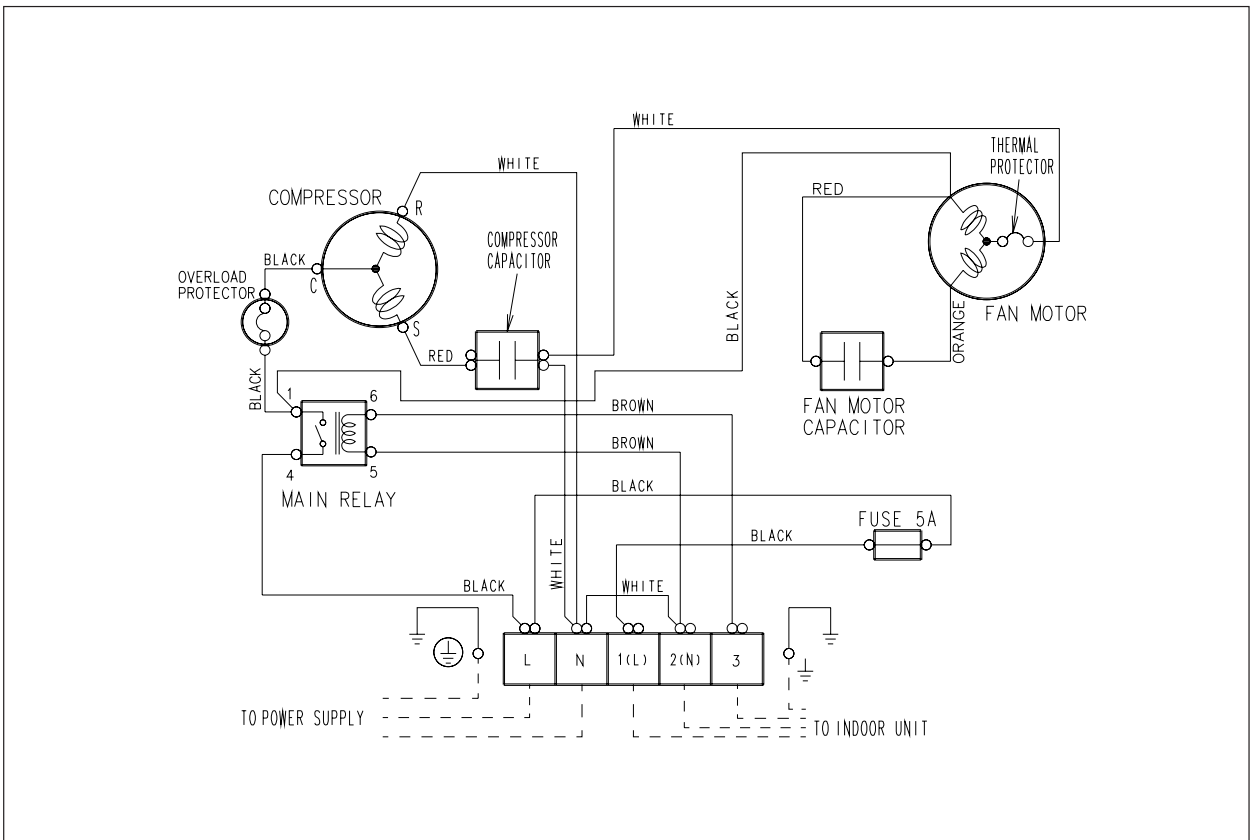
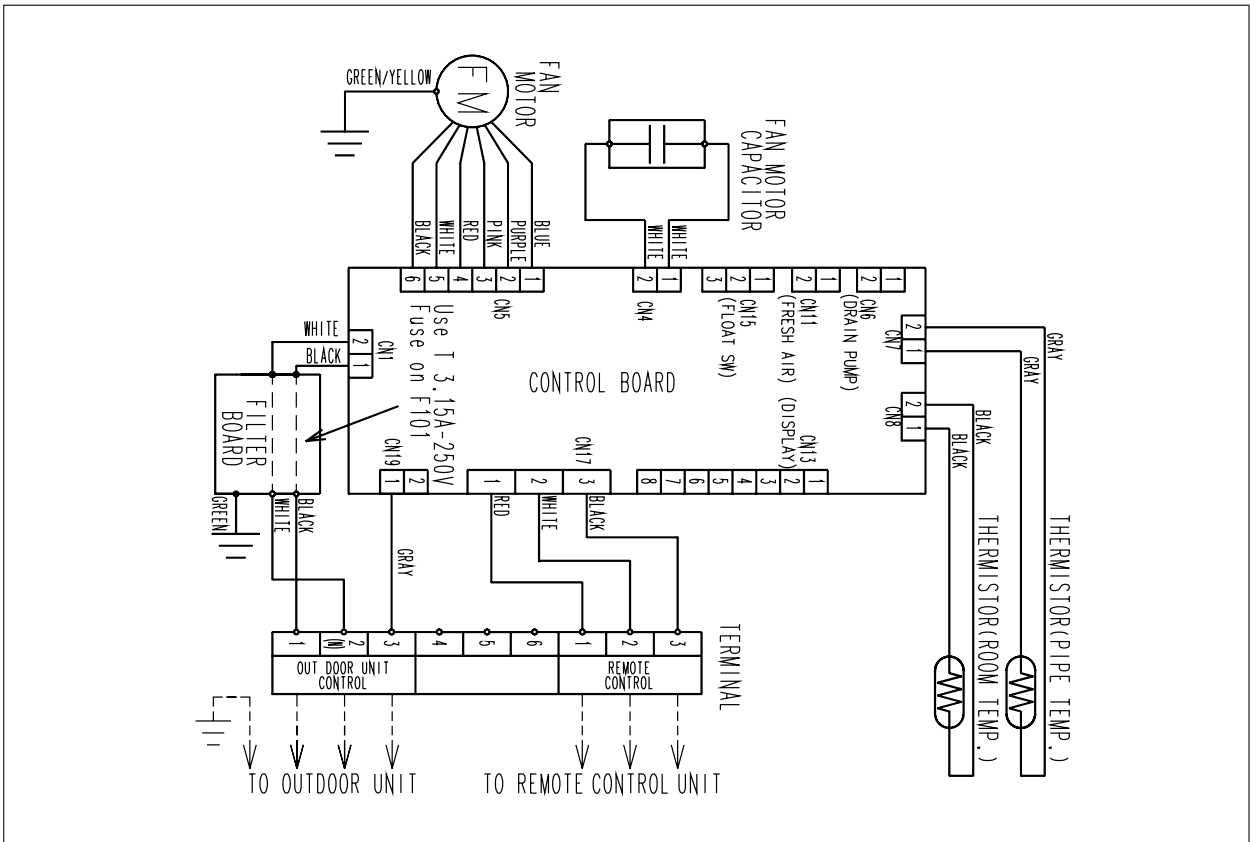

■ MODELS : AR\*12U / AO\*12U  
AR\*14U / AO\*14U

DUCT TYPE  
AR7 - AR18K

DUCT TYPE  
AR7 - AR18K

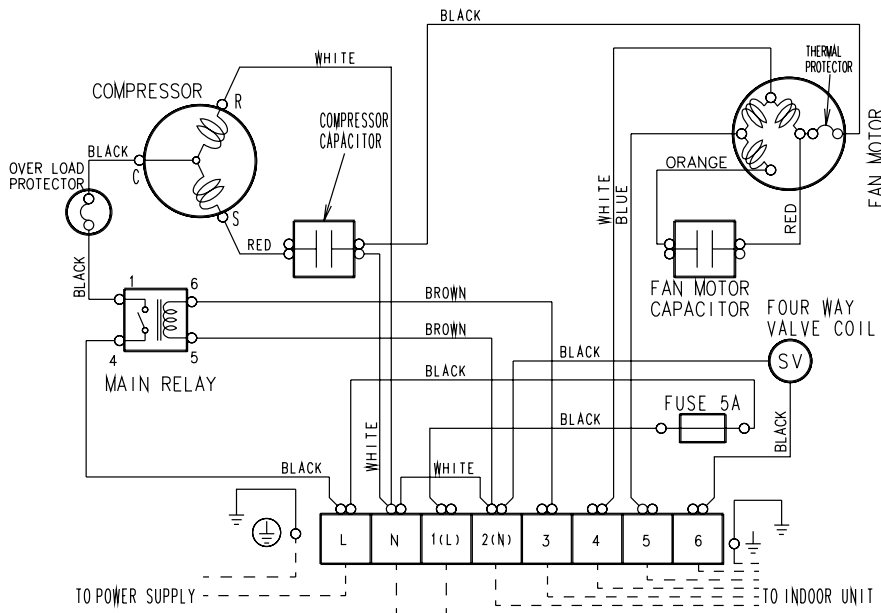
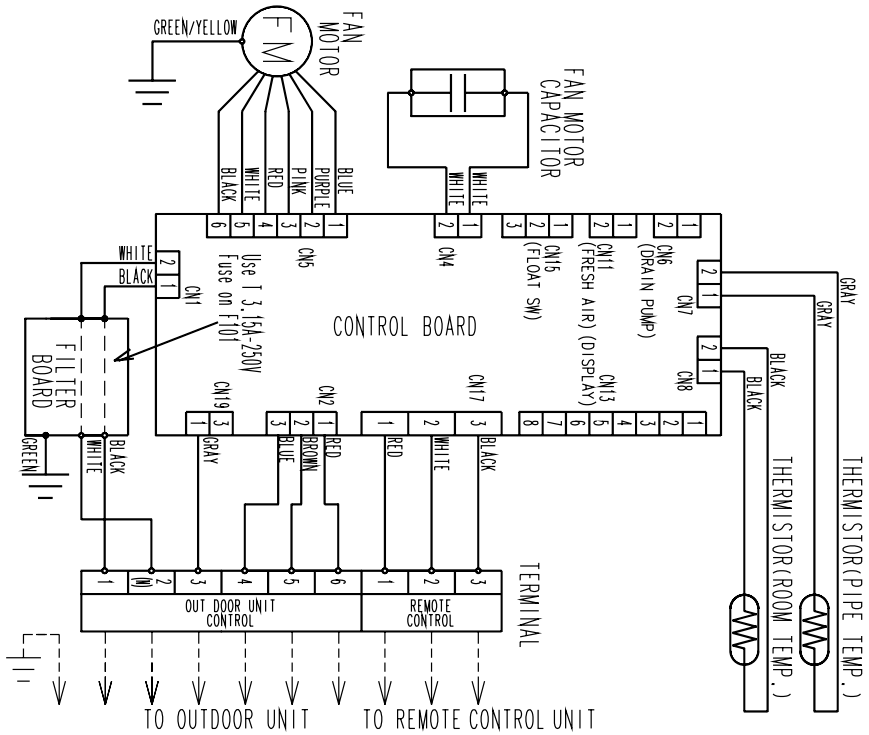

MODELS : AR\*18F / AO\*18F

DUCT TYPE  
AR7 - AR18K

DUCT TYPE  
AR7 - AR18K

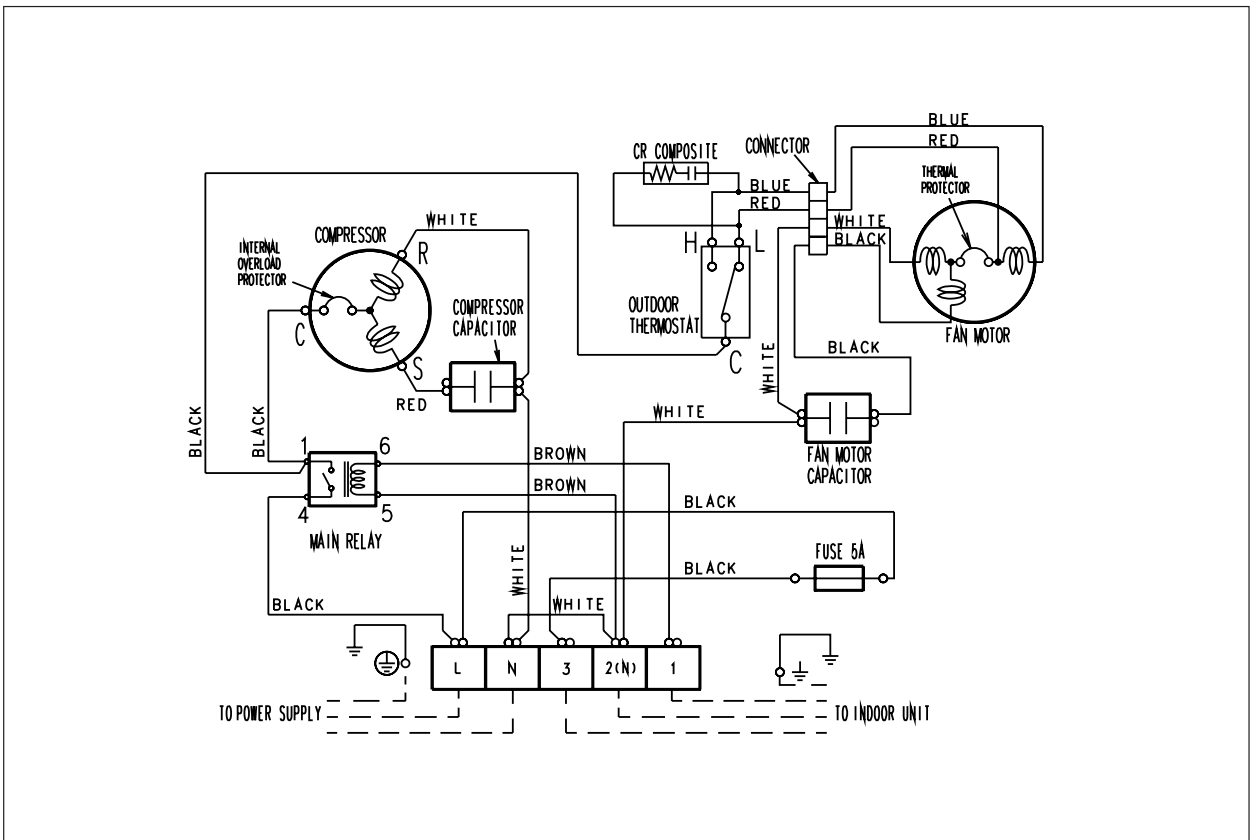
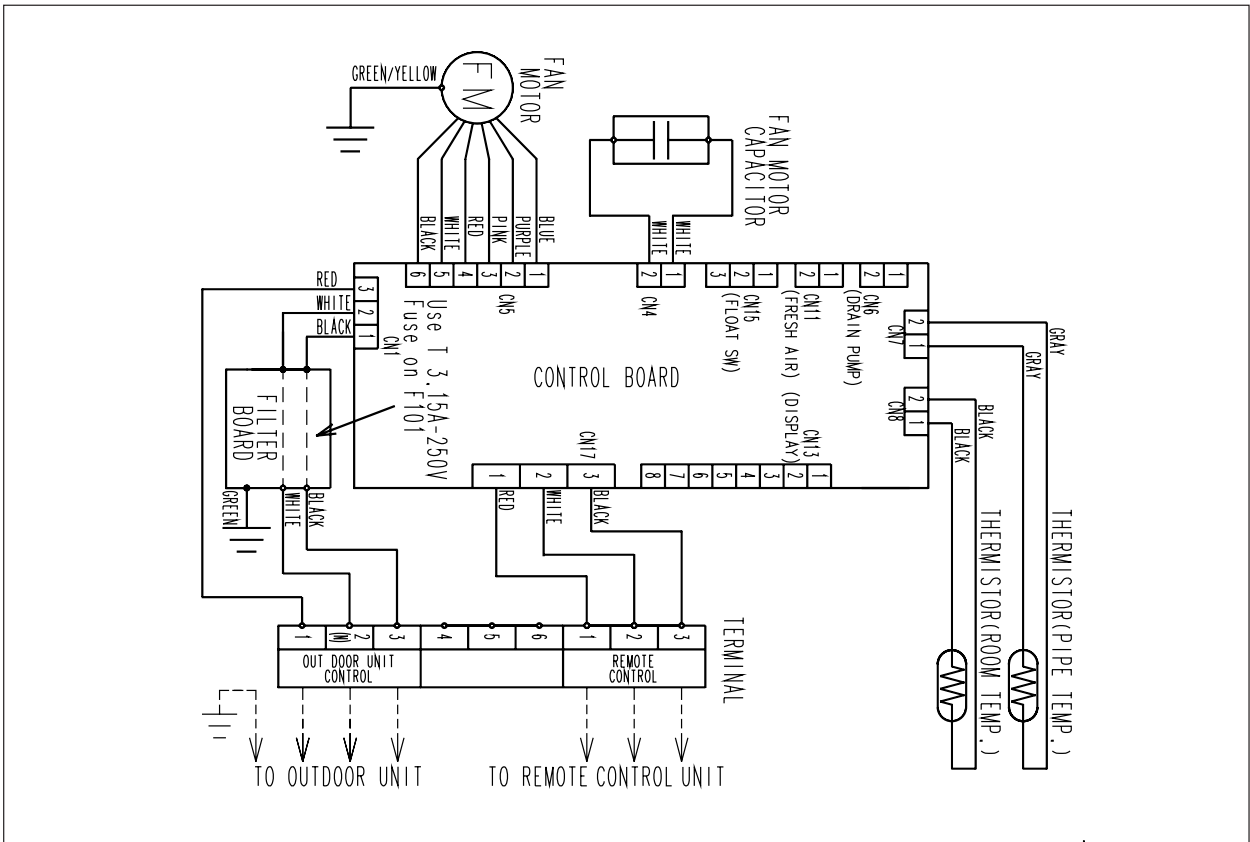

MODELS : AR\*18U / AO\*18U

DUCT TYPE  
AR7 - AR18K

DUCT TYPE  
AR7 - AR18K

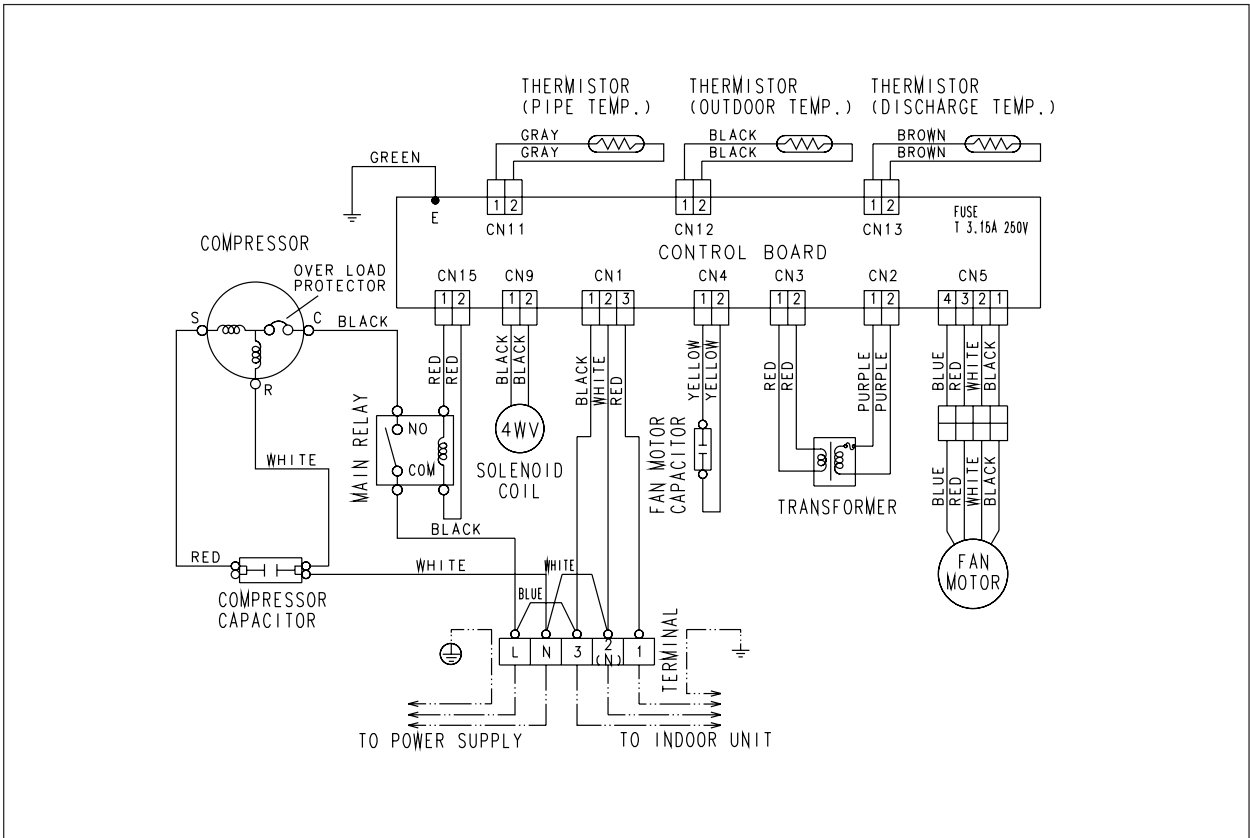
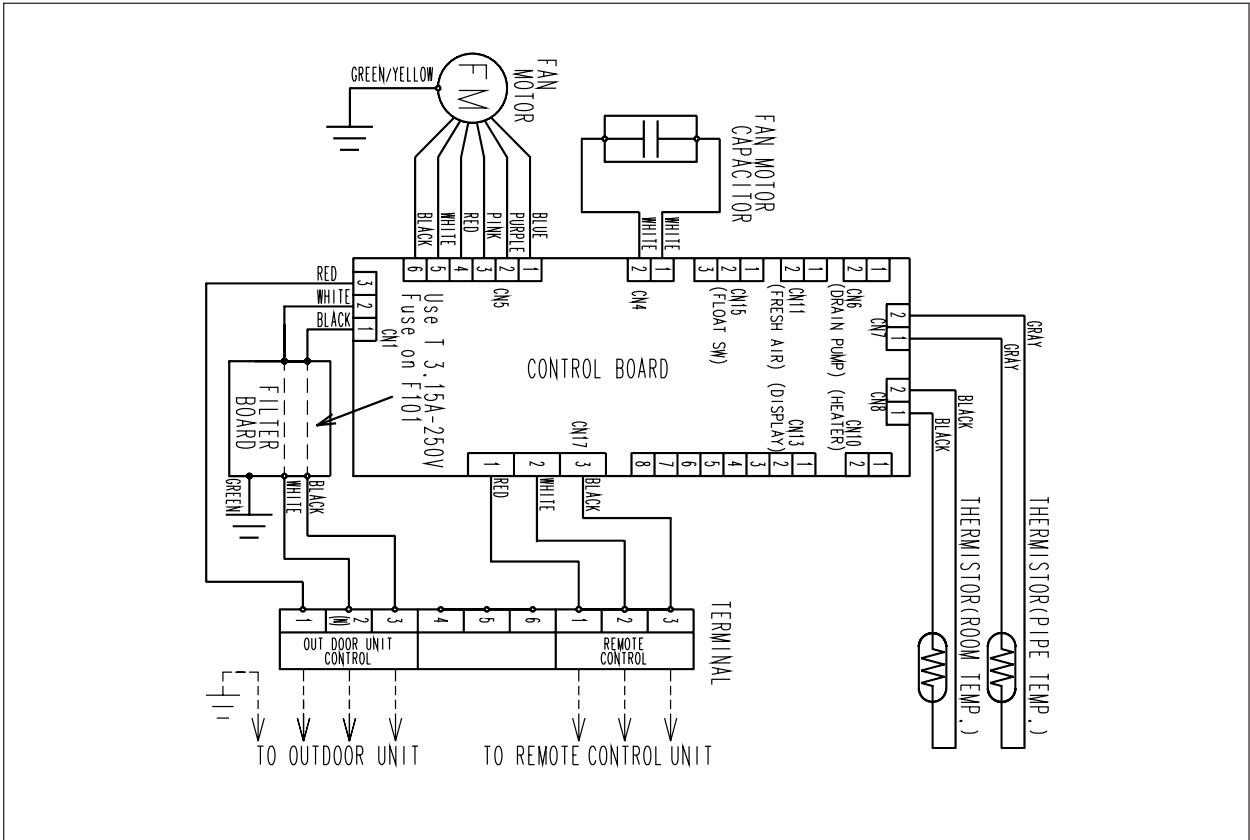

# 2-7. CAPACITY TABLE

## 2-7-1. COOLING

# COOLING CAPACITY

DUCT TYPE  
AR7 - AR18K

DUCT TYPE  
AR7 - AR18K

### MODELS : AR\*7U / AO\*7U

AFR 5.7

		Indoor temperature																							
		18 °CDB			21 °CDB			23 °CDB			26 °CDB			27 °CDB			29 °CDB			30 °CDB			32 °CDB		
		12 °CWB			15 °CWB			16 °CWB			18 °CWB			19 °CWB			21 °CWB			22 °CWB			23 °CWB		
Outdoor temperature	(°CDB)	TC	SHC	PI	TC	SHC	PI	TC	SHC	PI	TC	SHC	PI	TC	SHC	PI	TC	SHC	PI	TC	SHC	PI	TC	SHC	PI
	0	2.58	1.83	0.44	2.63	1.73	0.45	2.69	1.82	0.46	2.76	1.90	0.46	2.80	1.88	0.47	2.86	1.85	0.47	2.88	1.83	0.47	2.91	1.91	0.48
	5	2.49	1.76	0.50	2.55	1.67	0.51	2.61	1.77	0.51	2.70	1.86	0.52	2.74	1.85	0.52	2.81	1.83	0.53	2.84	1.81	0.53	2.87	1.89	0.54
	10	2.38	1.70	0.55	2.44	1.61	0.56	2.50	1.72	0.56	2.61	1.81	0.58	2.65	1.81	0.58	2.72	1.79	0.59	2.75	1.77	0.59	2.78	1.85	0.60
	15	2.27	1.64	0.60	2.33	1.55	0.61	2.39	1.66	0.62	2.48	1.76	0.63	2.52	1.75	0.64	2.59	1.74	0.65	2.63	1.73	0.65	2.66	1.81	0.66
	20	2.15	1.58	0.66	2.20	1.50	0.67	2.25	1.60	0.67	2.34	1.70	0.69	2.38	1.69	0.69	2.44	1.68	0.71	2.48	1.67	0.71	2.51	1.75	0.72
	25	2.24	1.63	0.61	2.29	1.55	0.62	2.35	1.65	0.63	2.43	1.74	0.64	2.47	1.73	0.64	2.54	1.72	0.65	2.57	1.71	0.65	2.60	1.79	0.66
	30	2.10	1.56	0.67	2.15	1.48	0.68	2.20	1.59	0.68	2.29	1.68	0.69	2.32	1.67	0.70	2.39	1.66	0.71	2.42	1.65	0.71	2.46	1.73	0.72
	35	1.95	1.49	0.73	1.99	1.41	0.74	2.04	1.51	0.74	2.11	1.60	0.75	2.15	1.60	0.76	2.22	1.59	0.77	2.25	1.58	0.77	2.29	1.67	0.78
	40	1.77	1.42	0.80	1.80	1.33	0.80	1.84	1.43	0.80	1.92	1.52	0.82	1.95	1.52	0.82	2.02	1.51	0.83	2.05	1.51	0.84	2.09	1.60	0.85
43	1.65	1.35	0.83	1.68	1.28	0.83	1.72	1.37	0.84	1.79	1.47	0.85	1.83	1.47	0.86	1.89	1.46	0.87	1.93	1.46	0.88	1.97	1.56	0.88	

### MODELS : AR\*7F / AO\*7F

AFR 5.7

		Indoor temperature																							
		18 °CDB			21 °CDB			23 °CDB			26 °CDB			27 °CDB			29 °CDB			30 °CDB			32 °CDB		
		12 °CWB			15 °CWB			16 °CWB			18 °CWB			19 °CWB			21 °CWB			22 °CWB			23 °CWB		
Outdoor temperature	(°CDB)	TC	SHC	PI	TC	SHC	PI	TC	SHC	PI	TC	SHC	PI	TC	SHC	PI	TC	SHC	PI	TC	SHC	PI	TC	SHC	PI
	21	2.31	1.74	0.57	2.36	1.65	0.57	2.41	1.75	0.58	2.49	1.85	0.59	2.53	1.84	0.59	2.60	1.83	0.60	2.63	1.82	0.61	2.66	1.90	0.61
	25	2.24	1.63	0.61	2.29	1.55	0.62	2.35	1.65	0.63	2.43	1.74	0.64	2.47	1.73	0.64	2.54	1.72	0.65	2.57	1.71	0.65	2.60	1.79	0.66
	30	2.10	1.56	0.67	2.15	1.48	0.68	2.20	1.59	0.68	2.29	1.68	0.69	2.32	1.67	0.70	2.39	1.66	0.71	2.42	1.65	0.71	2.46	1.73	0.72
	35	1.95	1.49	0.73	1.99	1.41	0.74	2.04	1.51	0.74	2.11	1.60	0.75	2.15	1.60	0.76	2.22	1.59	0.77	2.25	1.58	0.77	2.29	1.67	0.78
	40	1.77	1.42	0.80	1.80	1.33	0.80	1.84	1.43	0.80	1.92	1.52	0.82	1.95	1.52	0.82	2.02	1.51	0.83	2.05	1.51	0.84	2.09	1.60	0.84
	43	1.65	1.35	0.83	1.68	1.28	0.83	1.72	1.37	0.84	1.79	1.47	0.85	1.83	1.47	0.86	1.89	1.46	0.87	1.93	1.46	0.88	1.97	1.56	0.88

### MODELS : AR\*9U / AO\*9U

AFR 7.0

		Indoor temperature																							
		18 °CDB			21 °CDB			23 °CDB			26 °CDB			27 °CDB			29 °CDB			30 °CDB			32 °CDB		
		12 °CWB			15 °CWB			16 °CWB			18 °CWB			19 °CWB			21 °CWB			22 °CWB			23 °CWB		
Outdoor temperature	(°CDB)	TC	SHC	PI	TC	SHC	PI	TC	SHC	PI	TC	SHC	PI	TC	SHC	PI	TC	SHC	PI	TC	SHC	PI	TC	SHC	PI
	0	3.25	2.30	0.56	3.31	2.17	0.57	3.37	2.29	0.58	3.47	2.39	0.59	3.51	2.37	0.59	3.59	2.33	0.60	3.62	2.31	0.60	3.65	2.40	0.60
	5	3.13	2.21	0.63	3.20	2.10	0.64	3.28	2.23	0.65	3.39	2.34	0.66	3.44	2.33	0.66	3.53	2.30	0.67	3.56	2.28	0.67	3.60	2.38	0.68
	10	3.00	2.14	0.69	3.07	2.03	0.71	3.14	2.16	0.71	3.27	2.28	0.73	3.32	2.27	0.73	3.41	2.25	0.74	3.45	2.23	0.75	3.49	2.33	0.76
	15	2.85	2.06	0.76	2.92	1.95	0.77	3.00	2.09	0.78	3.12	2.21	0.80	3.17	2.20	0.81	3.26	2.18	0.82	3.30	2.17	0.82	3.34	2.27	0.83
	20	2.70	1.99	0.83	2.76	1.88	0.84	2.83	2.01	0.85	2.94	2.13	0.87	2.98	2.13	0.88	3.07	2.11	0.89	3.11	2.10	0.90	3.15	2.20	0.91
	25	2.81	2.05	0.78	2.88	1.94	0.78	2.95	2.07	0.79	3.05	2.19	0.80	3.10	2.18	0.81	3.19	2.16	0.82	3.22	2.15	0.82	3.26	2.25	0.83
	30	2.63	1.96	0.85	2.71	1.87	0.86	2.77	1.99	0.86	2.87	2.11	0.88	2.92	2.10	0.88	3.00	2.08	0.90	3.04	2.07	0.90	3.08	2.18	0.91
	35	2.45	1.88	0.93	2.49	1.77	0.93	2.56	1.90	0.94	2.65	2.02	0.95	2.70	2.01	0.96	2.79	2.00	0.97	2.83	1.99	0.98	2.87	2.10	0.98
	40	2.23	1.78	1.01	2.26	1.67	1.01	2.31	1.80	1.02	2.41	1.91	1.03	2.45	1.91	1.04	2.54	1.90	1.05	2.58	1.90	1.06	2.62	2.01	1.07
43	2.07	1.70	1.05	2.11	1.60	1.05	2.15	1.73	1.06	2.25	1.85	1.08	2.29	1.85	1.08	2.38	1.84	1.10	2.43	1.84	1.11	2.47	1.96	1.11	

### MODELS : AR\*9F / AO\*9F

AFR 7.0

		Indoor temperature																							
		18 °CDB			21 °CDB			23 °CDB			26 °CDB			27 °CDB			29 °CDB			30 °CDB			32 °CDB		
		12 °CWB			15 °CWB			16 °CWB			18 °CWB			19 °CWB			21 °CWB			22 °CWB			23 °CWB		
Outdoor temperature	(°CDB)	TC	SHC	PI	TC	SHC	PI	TC	SHC	PI	TC	SHC	PI	TC	SHC	PI	TC	SHC	PI	TC	SHC	PI	TC	SHC	PI
	21	3.01	2.29	0.74	3.07	2.18	0.75	3.14	2.31	0.75	3.25	2.44	0.76	3.30	2.43	0.77	3.39	2.41	0.78	3.43	2.40	0.79	3.47	2.51	0.80
	25	2.91	2.16	0.80	2.99	2.04	0.81	3.05	2.18	0.82	3.17	2.30	0.83	3.22	2.29	0.83	3.30	2.27	0.84	3.34	2.25	0.85	3.38	2.36	0.85
	30	2.73	2.06	0.88	2.81	1.96	0.88	2.87	2.09	0.89	2.98	2.21	0.90	3.03	2.21	0.91	3.11	2.19	0.92	3.16	2.18	0.93	3.20	2.29	0.93
	35	2.54	1.97	0.96	2.59	1.86	0.96	2.65	2.00	0.97	2.75	2.12	0.98	2.80	2.11	0.99	2.89	2.10	1.00	2.93	2.09	1.01	2.98	2.21	1.02
	40	2.31	1.87	1.04	2.34	1.76	1.04	2.40	1.89	1.05	2.50	2.01	1.06	2.54	2.01	1.07	2.63	2.00	1.09	2.68	1.99	1.09	2.72	2.11	1.10
	43	2.15	1.79	1.08	2.18	1.68	1.09	2.23	1.81	1.09	2.33	1.94	1.11	2.38	1.94	1.12	2.47	1.93	1.14	2.52	1.93	1.14	2.56	2.05	1.15

AFR: Air flow rate (m³/min)  
 TC : Total capacity (kW)  
 SHC: Sensible Heat capacity (kW)  
 PI : Power Input (kW)

## MODELS : AR\*12U / AO\*12U

## COOLING CAPACITY

AFR 8.3

		Indoor temperature																							
		18 °CDB			21 °CDB			23 °CDB			26 °CDB			27 °CDB			29 °CDB			30 °CDB			32 °CDB		
		12 °CWB			15 °CWB			16 °CWB			18 °CWB			19 °CWB			21 °CWB			22 °CWB			23 °CWB		
Outdoor temperature	(°CDB)	TC	SHC	PI	TC	SHC	PI	TC	SHC	PI	TC	SHC	PI	TC	SHC	PI	TC	SHC	PI	TC	SHC	PI	TC	SHC	PI
	0	4.21	3.05	0.72	4.29	2.89	0.74	4.37	3.05	0.75	4.50	3.17	0.76	4.55	3.15	0.76	4.65	3.09	0.77	4.69	3.07	0.77	4.73	3.19	0.78
	5	4.06	2.94	0.81	4.15	2.79	0.82	4.25	2.97	0.83	4.40	3.12	0.85	4.46	3.10	0.85	4.57	3.05	0.87	4.62	3.03	0.87	4.67	3.16	0.88
	10	3.88	2.84	0.89	3.98	2.69	0.91	4.08	2.87	0.92	4.24	3.03	0.94	4.31	3.02	0.95	4.42	2.99	0.96	4.47	2.97	0.97	4.52	3.10	0.98
	15	3.70	2.74	0.98	3.79	2.59	1.00	3.89	2.77	1.01	4.04	2.94	1.03	4.11	2.93	1.04	4.22	2.90	1.06	4.28	2.88	1.07	4.33	3.02	1.07
	20	3.50	2.65	1.07	3.58	2.50	1.09	3.67	2.68	1.10	3.81	2.84	1.12	3.87	2.83	1.13	3.98	2.80	1.15	4.03	2.79	1.16	4.08	2.93	1.17
	25	3.64	2.73	1.00	3.73	2.59	1.01	3.82	2.76	1.02	3.96	2.91	1.04	4.02	2.90	1.04	4.13	2.87	1.06	4.18	2.85	1.06	4.23	2.99	1.07
	30	3.41	2.60	1.10	3.51	2.48	1.11	3.59	2.65	1.12	3.72	2.80	1.13	3.78	2.80	1.14	3.89	2.77	1.16	3.95	2.76	1.16	4.00	2.90	1.17
	35	3.17	2.49	1.20	3.23	2.35	1.20	3.32	2.53	1.21	3.44	2.68	1.23	3.50	2.67	1.24	3.61	2.66	1.26	3.67	2.65	1.26	3.72	2.79	1.27
	40	2.89	2.37	1.30	2.93	2.22	1.30	3.00	2.39	1.31	3.12	2.54	1.33	3.18	2.54	1.34	3.29	2.53	1.36	3.34	2.52	1.37	3.40	2.67	1.39
43	2.68	2.26	1.36	2.73	2.13	1.36	2.79	2.30	1.37	2.91	2.46	1.39	2.97	2.46	1.40	3.08	2.45	1.42	3.14	2.45	1.43	3.20	2.60	1.44	

DUCT TYPE  
AR7 - AR18K

DUCT TYPE  
AR7 - AR18K

## MODELS : AR\*12F / AO\*12F

AFR 8.3

		Indoor temperature																							
		18 °CDB			21 °CDB			23 °CDB			26 °CDB			27 °CDB			29 °CDB			30 °CDB			32 °CDB		
		12 °CWB			15 °CWB			16 °CWB			18 °CWB			19 °CWB			21 °CWB			22 °CWB			23 °CWB		
Outdoor temperature	(°CDB)	TC	SHC	PI	TC	SHC	PI	TC	SHC	PI	TC	SHC	PI	TC	SHC	PI	TC	SHC	PI	TC	SHC	PI	TC	SHC	PI
	21	3.76	2.90	0.93	3.84	2.76	0.94	3.92	2.93	0.95	4.06	3.09	0.96	4.12	3.08	0.97	4.23	3.06	0.98	4.29	3.04	0.99	4.34	3.18	1.00
	25	3.64	2.73	1.00	3.73	2.59	1.01	3.82	2.76	1.02	3.96	2.91	1.04	4.02	2.90	1.04	4.13	2.87	1.06	4.18	2.85	1.06	4.23	2.99	1.07
	30	3.41	2.60	1.10	3.51	2.48	1.11	3.59	2.65	1.12	3.72	2.80	1.13	3.78	2.80	1.14	3.89	2.77	1.16	3.95	2.76	1.16	4.00	2.90	1.17
	35	3.17	2.49	1.20	3.23	2.35	1.20	3.32	2.53	1.21	3.44	2.68	1.23	3.50	2.67	1.24	3.61	2.66	1.26	3.67	2.65	1.26	3.72	2.79	1.27
	40	2.89	2.37	1.30	2.93	2.22	1.30	3.00	2.39	1.31	3.12	2.54	1.33	3.18	2.54	1.34	3.29	2.53	1.36	3.34	2.52	1.37	3.40	2.67	1.38
	43	2.68	2.26	1.36	2.73	2.13	1.36	2.79	2.30	1.37	2.91	2.46	1.39	2.97	2.46	1.40	3.08	2.45	1.42	3.14	2.45	1.43	3.20	2.60	1.44

## MODELS : AR\*14U / AO\*14U

AFR 10.7

		Indoor temperature																							
		18 °CDB			21 °CDB			23 °CDB			26 °CDB			27 °CDB			29 °CDB			30 °CDB			32 °CDB		
		12 °CWB			15 °CWB			16 °CWB			18 °CWB			19 °CWB			21 °CWB			22 °CWB			23 °CWB		
Outdoor temperature	(°CDB)	TC	SHC	PI	TC	SHC	PI	TC	SHC	PI	TC	SHC	PI	TC	SHC	PI	TC	SHC	PI	TC	SHC	PI	TC	SHC	PI
	0	4.81	3.39	0.82	4.90	3.20	0.85	5.00	3.38	0.85	5.14	3.52	0.87	5.20	3.50	0.87	5.31	3.43	0.88	5.36	3.40	0.89	5.41	3.54	0.89
	5	4.64	3.26	0.93	4.74	3.09	0.94	4.86	3.29	0.95	5.03	3.46	0.97	5.10	3.44	0.98	5.22	3.39	0.99	5.28	3.36	1.00	5.33	3.51	1.00
	10	4.44	3.15	1.02	4.55	2.99	1.04	4.66	3.19	1.06	4.85	3.37	1.08	4.92	3.35	1.08	5.05	3.32	1.10	5.11	3.29	1.11	5.17	3.44	1.12
	15	4.23	3.04	1.12	4.33	2.87	1.14	4.44	3.08	1.16	4.62	3.26	1.18	4.69	3.25	1.19	4.82	3.22	1.21	4.89	3.20	1.22	4.94	3.35	1.23
	20	4.00	2.94	1.23	4.09	2.78	1.25	4.19	2.97	1.26	4.35	3.15	1.29	4.42	3.14	1.30	4.55	3.11	1.32	4.61	3.09	1.33	4.67	3.25	1.34
	25	4.16	3.03	1.15	4.27	2.87	1.16	4.36	3.06	1.17	4.53	3.23	1.19	4.60	3.22	1.20	4.72	3.18	1.21	4.78	3.17	1.22	4.83	3.32	1.22
	30	3.90	2.89	1.26	4.01	2.75	1.27	4.10	2.94	1.28	4.25	3.11	1.30	4.32	3.10	1.31	4.45	3.08	1.32	4.51	3.06	1.33	4.57	3.22	1.34
	35	3.63	2.77	1.37	3.69	2.61	1.38	3.79	2.81	1.39	3.93	2.98	1.41	4.00	2.97	1.42	4.13	2.95	1.44	4.19	2.94	1.45	4.25	3.10	1.46
	40	3.30	2.63	1.49	3.35	2.47	1.49	3.43	2.65	1.50	3.57	2.82	1.52	3.64	2.82	1.54	3.76	2.81	1.56	3.82	2.80	1.57	3.88	2.97	1.59
43	3.07	2.51	1.56	3.12	2.37	1.56	3.19	2.55	1.57	3.33	2.73	1.59	3.40	2.73	1.60	3.52	2.72	1.63	3.59	2.72	1.64	3.66	2.89	1.65	

## MODELS : AR\*14F / AO\*14F

AFR 10.7

		Indoor temperature																							
		18 °CDB			21 °CDB			23 °CDB			26 °CDB			27 °CDB			29 °CDB			30 °CDB			32 °CDB		
		12 °CWB			15 °CWB			16 °CWB			18 °CWB			19 °CWB			21 °CWB			22 °CWB			23 °CWB		
Outdoor temperature	(°CDB)	TC	SHC	PI	TC	SHC	PI	TC	SHC	PI	TC	SHC	PI	TC	SHC	PI	TC	SHC	PI	TC	SHC	PI	TC	SHC	PI
	21	4.51	3.44	1.04	4.60	3.26	1.05	4.70	3.47	1.06	4.87	3.66	1.07	4.95	3.65	1.08	5.08	3.62	1.10	5.14	3.60	1.11	5.20	3.77	1.12
	25	4.37	3.23	1.12	4.48	3.06	1.14	4.58	3.27	1.15	4.75	3.45	1.16	4.83	3.44	1.17	4.96	3.40	1.19	5.02	3.38	1.19	5.07	3.54	1.20
	30	4.09	3.09	1.23	4.21	2.94	1.24	4.31	3.14	1.25	4.47	3.32	1.27	4.54	3.31	1.28	4.67	3.28	1.30	4.74	3.27	1.30	4.80	3.44	1.31
	35	3.81	2.96	1.34	3.88	2.78	1.35	3.98	3.00	1.36	4.13	3.18	1.38	4.20	3.17	1.39	4.33	3.15	1.41	4.40	3.14	1.42	4.46	3.31	1.43
	40	3.46	2.80	1.45	3.52	2.63	1.46	3.60	2.83	1.47	3.75	3.01	1.49	3.82	3.01	1.50	3.95	3.00	1.53	4.01	2.99	1.54	4.08	3.17	1.55
43	3.22	2.68	1.52	3.28	2.53	1.53	3.35	2.72	1.54	3.50	2.91	1.56	3.57	2.91	1.57	3.70	2.90	1.59	3.77	2.90	1.60	3.84	3.08	1.61	

AFR: Air flow rate (m<sup>3</sup>/min)  
 TC : Total capacity (kW)  
 SHC: Sensible Heat capacity (kW)  
 PI : Power Input (kW)

# MODELS : AR\*18U / AO\*18U

# COOLING CAPACITY

AFR 16.7

DUCT TYPE  
AR7 - AR18K

		Indoor temperature																										
		18 °CDB			21 °CDB			23 °CDB			26 °CDB			27 °CDB			29 °CDB			30 °CDB			32 °CDB					
		12 °CWB			15 °CWB			16 °CWB			18 °CWB			19 °CWB			21 °CWB			22 °CWB			23 °CWB					
Outdoor temperature	(°CDB)	TC	SHC	PI	TC	SHC	PI	TC	SHC	PI	TC	SHC	PI	TC	SHC	PI	TC	SHC	PI	TC	SHC	PI	TC	SHC	PI	TC	SHC	PI
	0	6.49	4.91	1.11	6.62	4.64	1.14	6.74	4.90	1.15	6.94	5.10	1.17	7.02	5.06	1.18	7.17	4.98	1.19	7.24	4.93	1.20	7.30	5.13	1.20			
	5	6.26	4.73	1.25	6.40	4.48	1.28	6.56	4.77	1.29	6.79	5.01	1.31	6.88	4.98	1.32	7.05	4.91	1.34	7.13	4.87	1.35	7.20	5.08	1.36			
	10	5.99	4.56	1.38	6.14	4.33	1.41	6.29	4.61	1.43	6.54	4.88	1.45	6.65	4.86	1.47	6.82	4.80	1.49	6.90	4.77	1.50	6.98	4.99	1.51			
	15	5.71	4.41	1.51	5.85	4.16	1.55	6.00	4.46	1.56	6.24	4.73	1.60	6.33	4.71	1.61	6.51	4.66	1.64	6.60	4.64	1.65	6.67	4.86	1.66			
	20	5.41	4.26	1.66	5.52	4.02	1.69	5.66	4.30	1.70	5.87	4.56	1.74	5.97	4.54	1.75	6.14	4.50	1.78	6.22	4.48	1.80	6.30	4.71	1.81			
	25	5.62	4.39	1.55	5.76	4.16	1.57	5.89	4.43	1.58	6.11	4.68	1.61	6.20	4.66	1.62	6.37	4.61	1.64	6.45	4.58	1.65	6.52	4.81	1.66			
	30	5.26	4.19	1.70	5.41	3.99	1.72	5.54	4.26	1.73	5.74	4.51	1.75	5.84	4.49	1.77	6.01	4.45	1.79	6.09	4.43	1.80	6.17	4.66	1.81			
	35	4.90	4.01	1.85	4.99	3.78	1.86	5.12	4.07	1.88	5.31	4.31	1.91	5.40	4.30	1.92	5.57	4.27	1.95	5.66	4.26	1.96	5.74	4.49	1.97			
	40	4.45	3.81	2.01	4.52	3.57	2.02	4.63	3.84	2.03	4.82	4.09	2.06	4.91	4.09	2.08	5.07	4.07	2.11	5.16	4.06	2.12	5.24	4.30	2.15			
43	4.14	3.63	2.10	4.21	3.43	2.11	4.31	3.69	2.12	4.50	3.95	2.15	4.59	3.95	2.17	4.76	3.94	2.20	4.85	3.94	2.21	4.94	4.18	2.23				

DUCT TYPE  
AR7 - AR18K

# MODELS : AR\*18F / AO\*18F

AFR 16.7

		Indoor temperature																										
		18 °CDB			21 °CDB			23 °CDB			26 °CDB			27 °CDB			29 °CDB			30 °CDB			32 °CDB					
		12 °CWB			15 °CWB			16 °CWB			18 °CWB			19 °CWB			21 °CWB			22 °CWB			23 °CWB					
Outdoor temperature	(°CDB)	TC	SHC	PI	TC	SHC	PI	TC	SHC	PI	TC	SHC	PI	TC	SHC	PI	TC	SHC	PI	TC	SHC	PI	TC	SHC	PI	TC	SHC	PI
	21	5.80	4.67	1.52	5.92	4.43	1.53	6.05	4.71	1.55	6.27	4.97	1.57	6.36	4.95	1.58	6.53	4.91	1.61	6.61	4.89	1.62	6.69	5.12	1.64			
	25	5.62	4.39	1.64	5.76	4.16	1.66	5.89	4.43	1.67	6.11	4.68	1.70	6.20	4.66	1.71	6.37	4.61	1.73	6.45	4.58	1.74	6.52	4.81	1.75			
	30	5.26	4.19	1.80	5.41	3.99	1.81	5.54	4.26	1.83	5.74	4.51	1.86	5.84	4.49	1.87	6.01	4.45	1.89	6.09	4.43	1.91	6.17	4.66	1.92			
	35	4.90	4.01	1.96	4.99	3.78	1.97	5.12	4.07	1.99	5.31	4.31	2.02	5.40	4.30	2.03	5.57	4.27	2.06	5.66	4.26	2.07	5.74	4.49	2.08			
	40	4.45	3.81	2.12	4.52	3.57	2.13	4.63	3.84	2.15	4.82	4.09	2.18	4.91	4.09	2.19	5.07	4.07	2.23	5.16	4.06	2.24	5.24	4.30	2.26			
	43	4.14	3.63	2.22	4.21	3.43	2.23	4.31	3.69	2.24	4.50	3.95	2.28	4.59	3.95	2.29	4.76	3.94	2.33	4.85	3.94	2.34	4.94	4.18	2.36			

AFR: Air flow rate (m<sup>3</sup>/min)  
 TC : Total capacity (kW)  
 SHC: Sensible Heat capacity (kW)  
 PI : Power Input (kW)



## 2-7-2. HEATING

## HEATING CAPACITY

### MODELS : AR\*7U / AO\*7U

AFR 5.7

			Indoor temperature													
			16 °CDB		18 °CDB		20 °CDB		23 °CDB		25 °CDB		27 °CDB		30 °CDB	
Outdoor temperature	(°CDB)	(°CWB)	TC	PI	TC	PI	TC	PI	TC	PI	TC	PI	TC	PI	TC	PI
	-6	-8	1.59	0.48	1.57	0.49	1.52	0.51	1.47	0.52	1.45	0.53	1.40	0.55	1.35	0.55
	-4	-6	1.74	0.52	1.72	0.53	1.67	0.55	1.62	0.56	1.59	0.57	1.54	0.59	1.49	0.59
	1	-1	1.96	0.59	1.94	0.60	1.89	0.62	1.84	0.63	1.81	0.64	1.76	0.65	1.72	0.66
	5	3	2.40	0.71	2.38	0.72	2.33	0.74	2.28	0.75	2.25	0.76	2.21	0.78	2.16	0.78
	7	6	2.52	0.73	2.50	0.74	2.45	0.76	2.40	0.78	2.38	0.78	2.33	0.80	2.28	0.81
	12	10	2.70	0.78	2.67	0.80	2.62	0.81	2.57	0.83	2.55	0.84	2.50	0.85	2.45	0.86
	15	13	2.72	0.81	2.70	0.83	2.65	0.84	2.60	0.86	2.57	0.87	2.52	0.88	2.47	0.89
	20	15	2.52	0.73	2.50	0.74	2.45	0.76	2.40	0.78	2.38	0.78	2.33	0.80	2.28	0.81
	24	17	2.38	0.68	2.35	0.70	2.30	0.71	2.25	0.73	2.23	0.74	2.18	0.75	2.13	0.76

### MODELS : AR\*9U / AO\*9U

AFR 7.0

			Indoor temperature													
			16 °CDB		18 °CDB		20 °CDB		23 °CDB		25 °CDB		27 °CDB		30 °CDB	
Outdoor temperature	(°CDB)	(°CWB)	TC	PI	TC	PI	TC	PI	TC	PI	TC	PI	TC	PI	TC	PI
	-6	-8	2.02	0.60	1.98	0.62	1.92	0.64	1.86	0.66	1.83	0.67	1.77	0.69	1.71	0.70
	-4	-6	2.20	0.65	2.17	0.67	2.11	0.69	2.05	0.71	2.02	0.72	1.95	0.74	1.89	0.75
	1	-1	2.48	0.74	2.45	0.76	2.39	0.78	2.33	0.80	2.29	0.81	2.23	0.83	2.17	0.84
	5	3	3.04	0.89	3.01	0.91	2.95	0.93	2.88	0.95	2.85	0.96	2.79	0.98	2.73	0.99
	7	6	3.19	0.92	3.16	0.94	3.10	0.96	3.04	0.98	3.01	0.99	2.95	1.01	2.88	1.02
	12	10	3.41	0.99	3.38	1.01	3.32	1.03	3.26	1.05	3.22	1.06	3.16	1.08	3.10	1.08
	15	13	3.44	1.03	3.41	1.05	3.35	1.07	3.29	1.08	3.26	1.09	3.19	1.11	3.13	1.12
	20	15	3.19	0.92	3.16	0.94	3.10	0.96	3.04	0.98	3.01	0.99	2.95	1.01	2.88	1.02
	24	17	3.01	0.86	2.98	0.88	2.91	0.90	2.85	0.92	2.82	0.93	2.76	0.95	2.70	0.96

### MODELS : AR\*12U / AO\*12U

AFR 8.3

			Indoor temperature													
			16 °CDB		18 °CDB		20 °CDB		23 °CDB		25 °CDB		27 °CDB		30 °CDB	
Outdoor temperature	(°CDB)	(°CWB)	TC	PI	TC	PI	TC	PI	TC	PI	TC	PI	TC	PI	TC	PI
	-6	-8	2.60	0.76	2.56	0.79	2.48	0.81	2.40	0.83	2.36	0.85	2.28	0.87	2.20	0.88
	-4	-6	2.84	0.82	2.80	0.85	2.72	0.87	2.64	0.90	2.60	0.91	2.52	0.93	2.44	0.94
	1	-1	3.20	0.93	3.16	0.96	3.08	0.98	3.00	1.00	2.96	1.02	2.88	1.04	2.80	1.05
	5	3	3.92	1.13	3.88	1.15	3.80	1.17	3.72	1.20	3.68	1.21	3.60	1.23	3.52	1.25
	7	6	4.12	1.16	4.08	1.19	4.00	1.21	3.92	1.23	3.88	1.25	3.80	1.27	3.72	1.28
	12	10	4.40	1.25	4.36	1.27	4.28	1.29	4.20	1.32	4.16	1.33	4.08	1.36	4.00	1.37
	15	13	4.44	1.29	4.40	1.32	4.32	1.34	4.24	1.37	4.20	1.38	4.12	1.40	4.04	1.42
	20	15	4.12	1.16	4.08	1.19	4.00	1.21	3.92	1.23	3.88	1.25	3.80	1.27	3.72	1.28
	24	17	3.88	1.09	3.84	1.11	3.76	1.14	3.68	1.16	3.64	1.17	3.56	1.20	3.48	1.21

## MODELS : AR\* 14U / AO\*14U

## HEATING CAPACITY

AFR | 10.7

DUCT TYPE  
AR7 - AR18K

			Indoor temperature													
			16 °CDB		18 °CDB		20 °CDB		23 °CDB		25 °CDB		27 °CDB		30 °CDB	
Outdoor temperature	(°CDB)	(°CWB)	TC	PI	TC	PI	TC	PI	TC	PI	TC	PI	TC	PI	TC	PI
	-6	-8	3.06	0.85	3.01	0.88	2.91	0.90	2.82	0.93	2.77	0.95	2.68	0.97	2.59	0.99
	-4	-6	3.34	0.92	3.29	0.95	3.20	0.97	3.10	1.00	3.06	1.01	2.96	1.04	2.87	1.05
	1	-1	3.76	1.04	3.71	1.07	3.62	1.09	3.53	1.12	3.48	1.13	3.38	1.16	3.29	1.17
	5	3	4.61	1.26	4.56	1.28	4.47	1.31	4.37	1.34	4.32	1.35	4.23	1.38	4.14	1.39
	7	6	4.84	1.30	4.79	1.32	4.70	1.35	4.61	1.38	4.56	1.39	4.47	1.42	4.37	1.43
	12	10	5.17	1.39	5.12	1.42	5.03	1.44	4.94	1.47	4.89	1.49	4.79	1.51	4.70	1.53
	15	13	5.22	1.44	5.17	1.47	5.08	1.50	4.98	1.53	4.94	1.54	4.84	1.57	4.75	1.58
	20	15	4.84	1.30	4.79	1.32	4.70	1.35	4.61	1.38	4.56	1.39	4.47	1.42	4.37	1.43
	24	17	4.56	1.22	4.51	1.24	4.42	1.27	4.32	1.30	4.28	1.31	4.18	1.34	4.09	1.35

DUCT TYPE  
AR7 - AR18K

## MODELS : AR\* 18U / AO\*18U

AFR | 16.7

			Indoor temperature													
			16 °CDB		18 °CDB		20 °CDB		23 °CDB		25 °CDB		27 °CDB		30 °CDB	
Outdoor temperature	(°CDB)	(°CWB)	TC	PI	TC	PI	TC	PI	TC	PI	TC	PI	TC	PI	TC	PI
	-6	-8	3.90	1.18	3.84	1.22	3.72	1.25	3.60	1.29	3.54	1.31	3.42	1.35	3.30	1.37
	-4	-6	4.26	1.27	4.20	1.31	4.08	1.35	3.96	1.38	3.90	1.40	3.78	1.44	3.66	1.46
	1	-1	4.80	1.44	4.74	1.48	4.62	1.51	4.50	1.55	4.44	1.57	4.32	1.61	4.20	1.63
	5	3	5.88	1.74	5.82	1.78	5.70	1.81	5.58	1.85	5.52	1.87	5.40	1.91	5.28	1.93
	7	6	6.18	1.80	6.12	1.83	6.00	1.87	5.88	1.91	5.82	1.93	5.70	1.96	5.58	1.98
	12	10	6.60	1.93	6.54	1.96	6.42	2.00	6.30	2.04	6.24	2.06	6.12	2.09	6.00	2.11
	15	13	6.66	2.00	6.60	2.04	6.48	2.08	6.36	2.11	6.30	2.13	6.18	2.17	6.06	2.19
	20	15	6.18	1.80	6.12	1.83	6.00	1.87	5.88	1.91	5.82	1.93	5.70	1.96	5.58	1.98
	24	17	5.82	1.68	5.76	1.72	5.64	1.76	5.52	1.80	5.46	1.81	5.34	1.85	5.22	1.87

AFR: Air flow rate (m<sup>3</sup>/min)

TC : Total capacity (kW)

SHC: Sensible Heat capacity (kW)

PI : Power Input (kW)

## 2-8. CAPACITY COMPENSATION FOR PIPE LENGTH AND HEIGHT DIFFERENCE

DUCT TYPE  
AR7 - AR18K

DUCT TYPE  
AR7 - AR18K

- MODELS: AR\*7U / AO\*7U
- AR\*9U / AO\*9U
- AR\*12U / AO\*12U
- AR\*14U / AO\*14U

### ● COEFFICIENT OF COMPENSATION FOR PIPE LENGTH

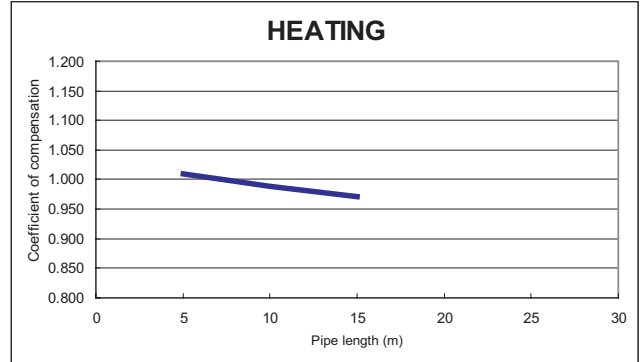
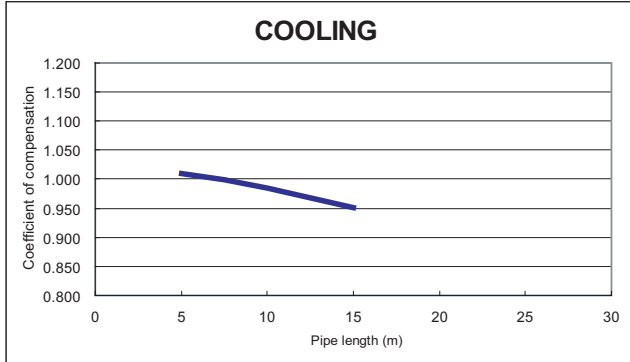

### ● COEFFICIENT OF COMPENSATION FOR HEIGHT DIFFERENCE

COOLING			PIPE LENGTH (m)			
			5	7.5	10	15
HEIGHT DIFFERENCE (m)	Outdoor unit is bottom-side		-	-	-	-
			-	-	-	-
		8	-	1.000	0.985	0.952
		5	1.010	1.000	0.985	0.952
	Outdoor unit is up-side	0	1.010	1.000	0.985	0.952
		-5	1.002	0.992	0.977	0.944
		-8	-	0.988	0.973	0.941
			-	-	-	-

HEATING			PIPE LENGTH (m)			
			5	7.5	10	15
HEIGHT DIFFERENCE (m)	Outdoor unit is bottom-side		-	-	-	-
			-	-	-	-
		8	-	0.993	0.982	0.964
		5	1.005	0.995	0.984	0.966
	Outdoor unit is up-side	0	1.010	1.000	0.989	0.971
		-5	1.010	1.000	0.989	0.971
		-8	-	1.000	0.989	0.971
			-	-	-	-

**MODELS: AR\*7F / AO\*7F**  
**AR\*9F / AO\*9F**  
**AR\*12F / AO\*12F**  
**AR\*14F / AO\*14F**

DUCT TYPE  
AR7 - AR18K

DUCT TYPE  
AR7 - AR18K

● **COEFFICIENT OF COMPENSATION FOR PIPE LENGTH**

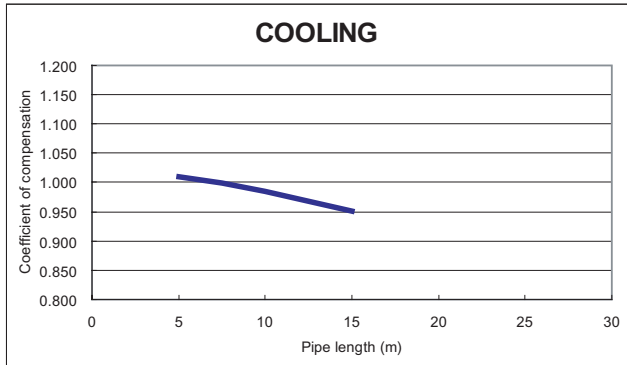

● **COEFFICIENT OF COMPENSATION FOR HEIGHT DIFFERENCE**

COOLING			PIPE LENGTH (m)			
			5	7.5	10	15
HEIGHT DIFFERENCE (m)	Outdoor unit is bottom-side		-	-	-	-
			-	-	-	-
		8	-	1.000	0.985	0.952
		5	1.010	1.000	0.985	0.952
	0	1.010	1.000	0.985	0.952	
	Outdoor unit is up-side	-5	1.002	0.992	0.977	0.944
		-8	-	0.988	0.973	0.941
			-	-	-	-
		-	-	-	-	

# MODELS: AR \* 18U / AO \* 18U

## COEFFICIENT OF COMPENSATION FOR PIPE LENGTH

DUCT TYPE  
AR7 - AR18K

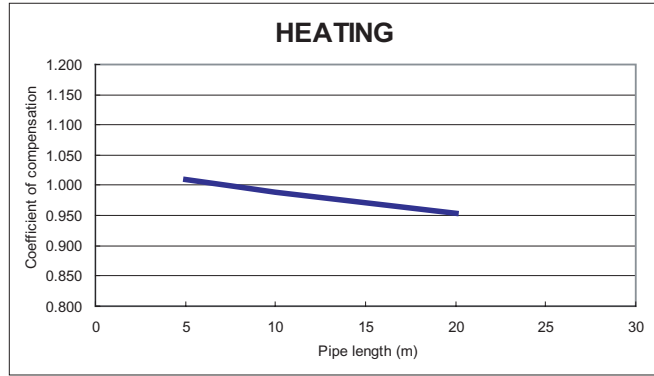
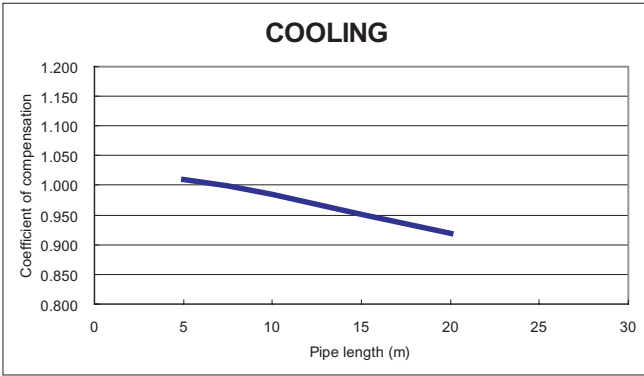

DUCT TYPE  
AR7 - AR18K

## COEFFICIENT OF COMPENSATION FOR HEIGHT DIFFERENCE

COOLING			PIPE LENGTH (m)				
			5	7.5	10	15	20
HEIGHT DIFFERENCE (m)	Outdoor unit is bottom-side		-	-	-	-	-
			-	-	-	-	-
		8	-	1.000	0.985	0.952	0.919
		5	1.010	1.000	0.985	0.952	0.919
	Outdoor unit is up-side	0	1.010	1.000	0.985	0.952	0.919
		-5	1.002	0.992	0.977	0.944	0.912
		-8	-	0.988	0.973	0.941	0.908
			-	-	-	-	-

HEATING			PIPE LENGTH (m)				
			5	7.5	10	15	20
HEIGHT DIFFERENCE (m)	Outdoor unit is bottom-side		-	-	-	-	-
			-	-	-	-	-
		8	-	0.993	0.982	0.964	0.946
		5	1.005	0.995	0.984	0.966	0.948
	Outdoor unit is up-side	0	1.010	1.000	0.989	0.971	0.953
		-5	1.010	1.000	0.989	0.971	0.953
		-8	-	1.000	0.989	0.971	0.953
			-	-	-	-	-

## MODELS: AR\*18F / AO\*18F

DUCT TYPE  
AR7 - AR18K

DUCT TYPE  
AR7 - AR18K

### ● COEFFICIENT OF COMPENSATION FOR PIPE LENGTH

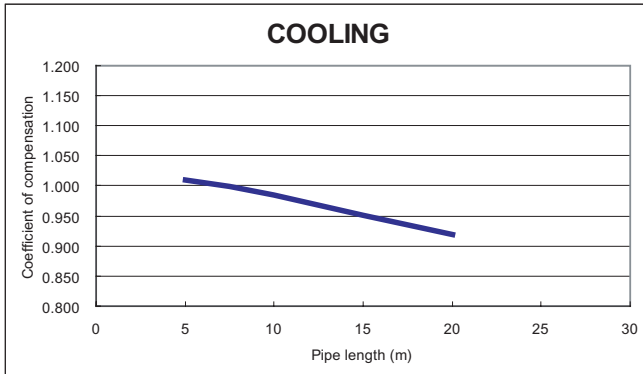

### ● COEFFICIENT OF COMPENSATION FOR HEIGHT DIFFERENCE

COOLING			PIPE LENGTH (m)				
			5	7.5	10	15	20
HEIGHT DIFFERENCE (m)	Outdoor unit is bottom-side	-	-	-	-	-	-
		-	-	-	-	-	-
		8	-	1.000	0.985	0.952	0.919
		5	1.010	1.000	0.985	0.952	0.919
		0	1.010	1.000	0.985	0.952	0.919
	Outdoor unit is up-side	-5	1.002	0.992	0.977	0.944	0.912
		-8	-	0.988	0.973	0.941	0.908
		-	-	-	-	-	-
		-	-	-	-	-	-
		-	-	-	-	-	-

## 2-9. ADDITIONAL CHARGE CALCULATION

■ MODELS : AR\*7F / AO\*7F , AR\*9F / AO\*9F  
AR\*12F / AO\*12F , AR\*14F / AO\*14F

### ● REFRIGERANT CHARGE

TYPE		DUCTED MODEL				
		COOLING TYPE				
MODEL NAME	INDOOR	AR*7F	AR*9F	AR*12F	AR*14F	AR*18F
	OUTDOOR	AO*7F	AO*9F	AO*12F	AO*14F	AO*18F
PRECHARGE	REFREGERANT TYPE	R410A				
	CHARGELESS PIPE LENGTH	m	7.5	7.5	7.5	7.5
	AMOUNT		550	600	800	900
ADITIONAL charge	10m	g	550+38	600+38	800+38	900+38
	15m		550+113	600+113	800+113	900+113
	20m		-	-	-	900+250
	g/m		15	15	15	15
						20

■ MODELS : AR\*7U / AO\*7U , AR\*9U / AO\*9U  
AR\*12U / AO\*12U , AR\*14U / AO\*14U

### ● REFRIGERANT CHARGE

TYPE		DUCTED MODEL				
		HEAT PUMP TYPE				
MODEL NAME	INDOOR	AR*7U	AR*9U	AR*12U	AR*14U	AR*18U
	OUTDOOR	AO*7U	AO*9U	AO*12U	AO*14U	AO*18U
PRECHARGE	REFREGERANT TYPE	R410A				
	CHARGELESS PIPE LENGTH	m	7.5	7.5	7.5	7.5
	AMOUNT		650	750	850	1000
ADITIONAL charge	10m	g	650+38	750+38	850+38	1000+38
	15m		650+113	750+113	850+113	1000+113
	20m		-	-	-	1400+250
	g/m		15	15	15	15
						20

## 2-10. OPERATION RANGE

DUCT TYPE  
AR7 - AR18K

Model		Mode	Operation Range		
Indoor unit	Outdoor unit		Indoor unit	Indoor humidity	Outdoor unit
AR*7F AR*9F AR*12F AR*14F	AO*7F AO*9F AO*12F AO*14F	Cooling Dry	18 to 32 °C	80% or less	21 to 43 °C

DUCT TYPE  
AR7 - AR18K

Model		Mode	Operation Range		
Indoor unit	Outdoor unit		Indoor unit	Indoor humidity	Outdoor unit
AR*18F	AO*18F	Cooling Dry	18 to 32 °C	80% or less	0 to 43 °C

Model		Mode	Operation Range		
Indoor unit	Outdoor unit		Indoor unit	Indoor humidity	Outdoor unit
AR*7U AR*9U AR*12U AR*14U AR*18U	AO*7U AO*9U AO*12U AO*14U AO*18U	Cooling Dry	18 to 32 °C	80% or less	0 to 43 °C
		Heating	16 to 30 °C		-6 to 24 °C



# 2-11. FAN PERFORMANCE AND AIR FLOW

## 2-11-1. NORMAL MODE

■ MODELS : AR\*7F, AR\*7U

● 230V

DUCT TYPE  
AR7 - AR18K

DUCT TYPE  
AR7 - AR18K

230V			Static pressure (Pa)	
			0	20
FAN SPEED	Hi	m <sup>3</sup> /h	340	290
		l/s	94	81
		CFM	200	171
	Med	m <sup>3</sup> /h	320	270
		l/s	89	75
		CFM	188	159
	Low	m <sup>3</sup> /h	300	250
		l/s	83	69
		CFM	177	147

Q-h Characteristic curve

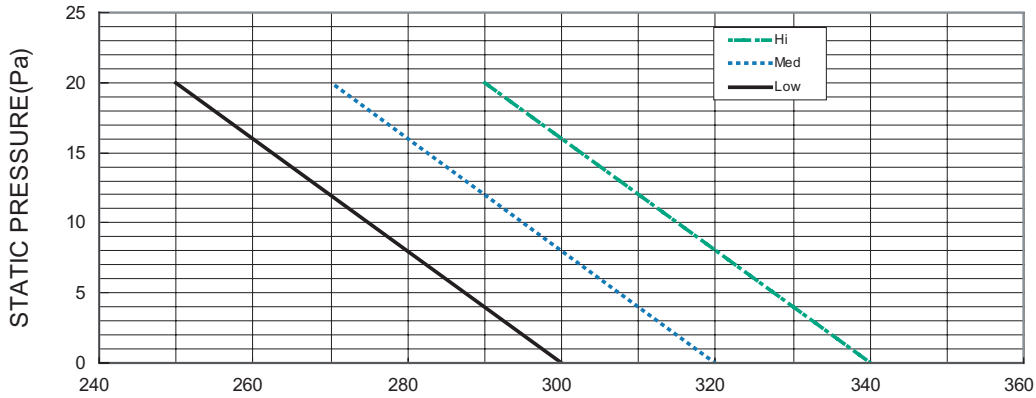

COOLING

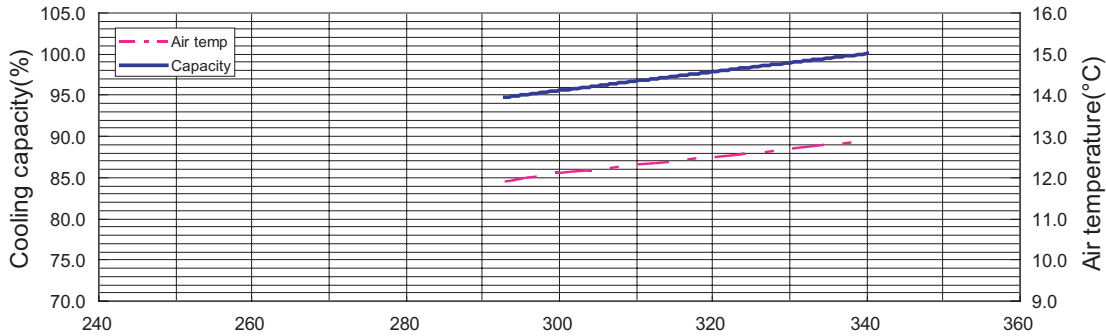

HEATING

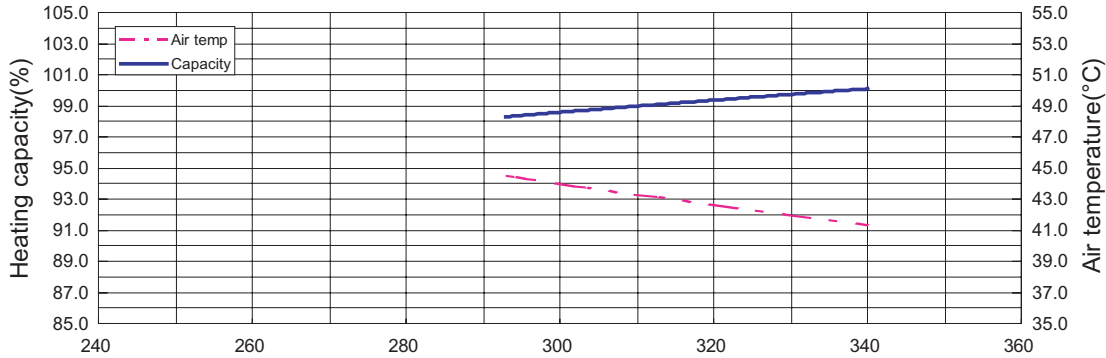

AIR FLOW (m<sup>3</sup>/h)

Test condition : No filter and Fan mode.

# MODELS : AR\*9F, AR\*9U

● 230V

DUCT TYPE  
AR7 - AR18K

DUCT TYPE  
AR7 - AR18K

230V			Static pressure (Pa)	
			0	20
FAN SPEED	Hi	m <sup>3</sup> /h	420	380
		l/s	117	106
		CFM	247	224
	Med	m <sup>3</sup> /h	390	350
		l/s	108	97
		CFM	230	206
	Low	m <sup>3</sup> /h	360	330
		l/s	100	92
		CFM	212	194

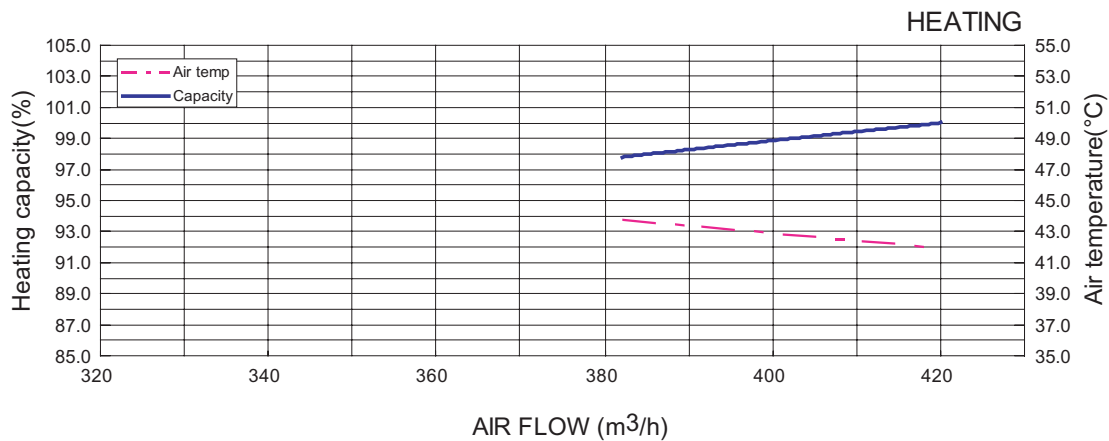
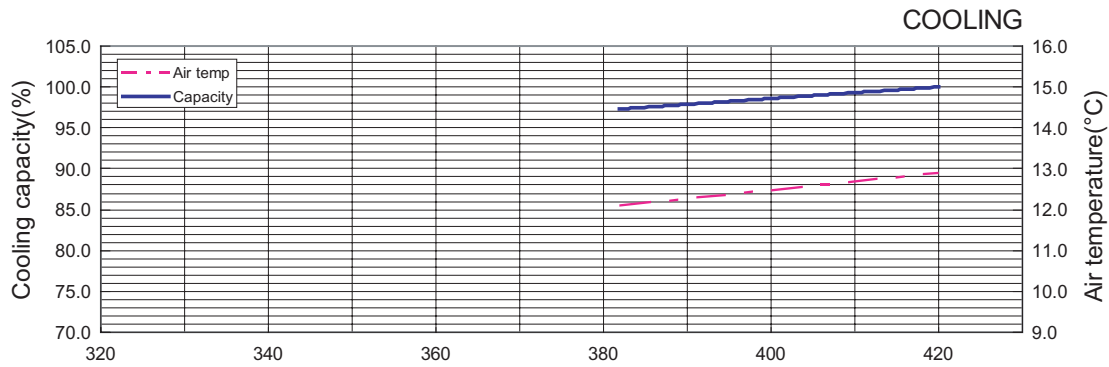
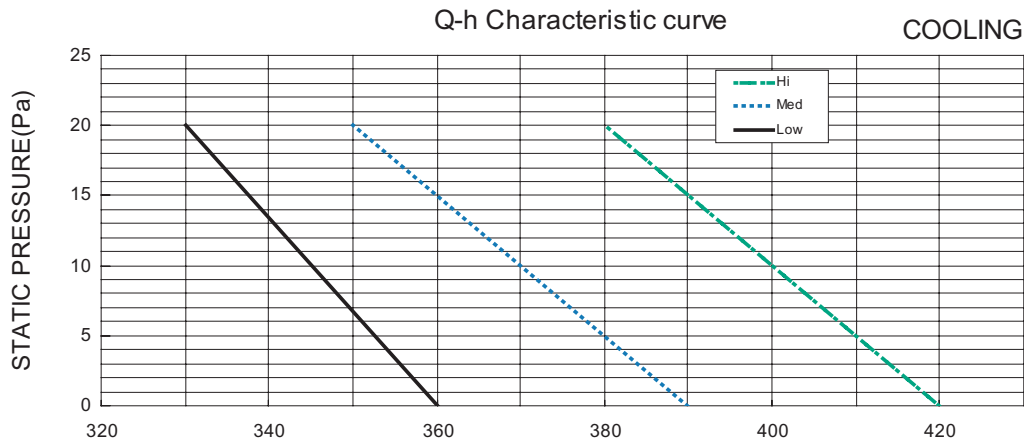

Test condition : No filter and Fan mode.

# MODELS : AR\*12F, AR\*12U

● 230V

DUCT TYPE  
AR7 - AR18K

DUCT TYPE  
AR7 - AR18K

230V		Static pressure (Pa)		
		0	20	
FAN SPEED	Hi	m <sup>3</sup> /h	500	430
		l/s	139	119
		CFM	294	253
	Med	m <sup>3</sup> /h	450	390
		l/s	125	108
		CFM	265	230
	Low	m <sup>3</sup> /h	400	340
		l/s	111	94
		CFM	235	200

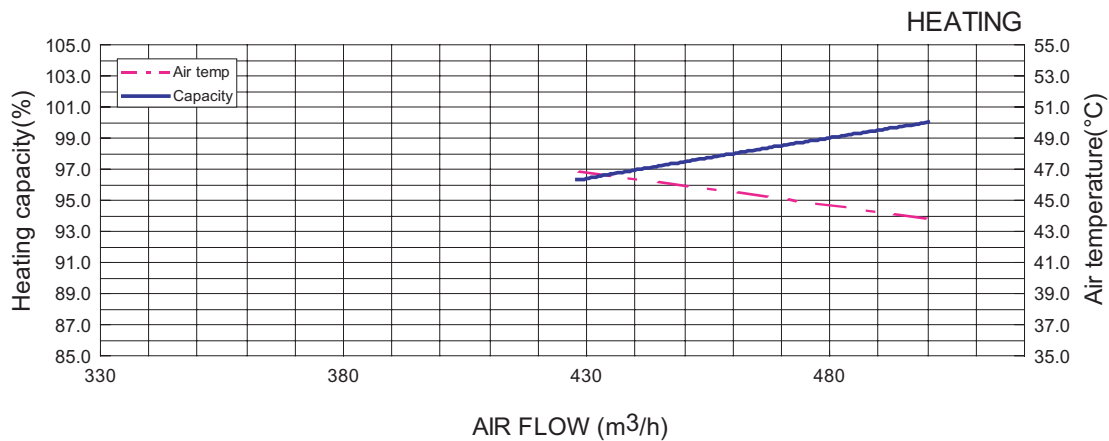
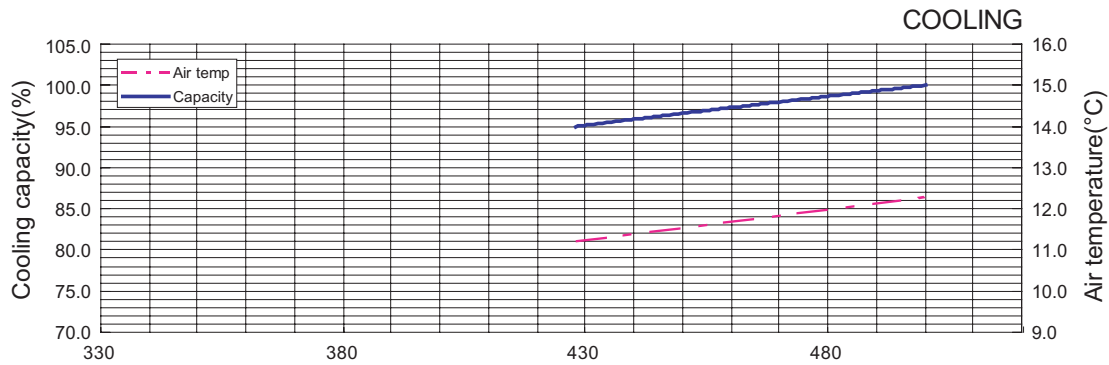
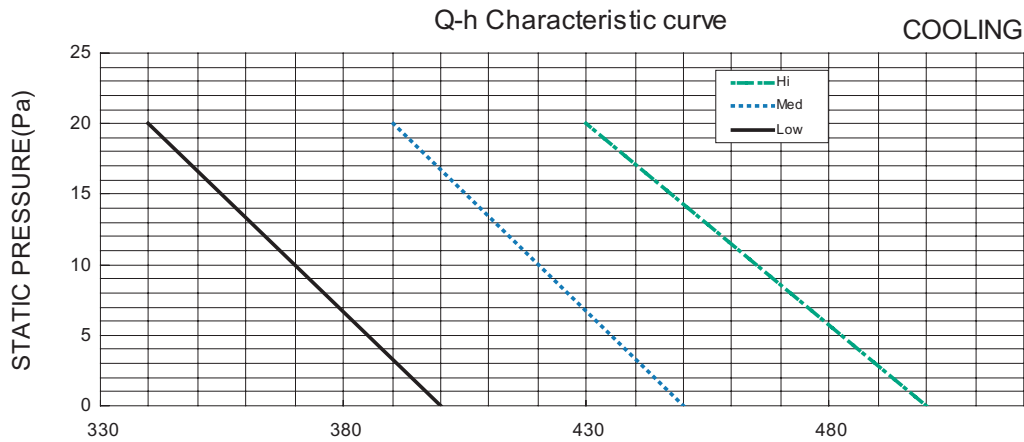

Test condition : No filter and Fan mode.

# MODELS : AR\*14F, AR\*14U

● 230V

DUCT TYPE  
AR7 - AR18K

DUCT TYPE  
AR7 - AR18K

230V			Static pressure (Pa)	
			0	20
FAN SPEED	Hi	m <sup>3</sup> /h	640	560
		l/s	178	156
		CFM	377	330
	Med	m <sup>3</sup> /h	560	500
		l/s	156	139
		CFM	330	294
	Low	m <sup>3</sup> /h	480	430
		l/s	133	119
		CFM	283	253

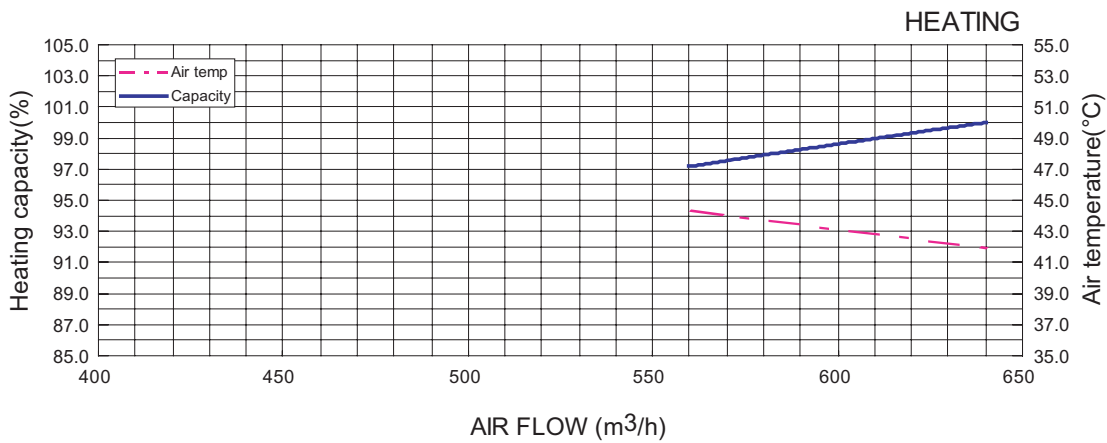
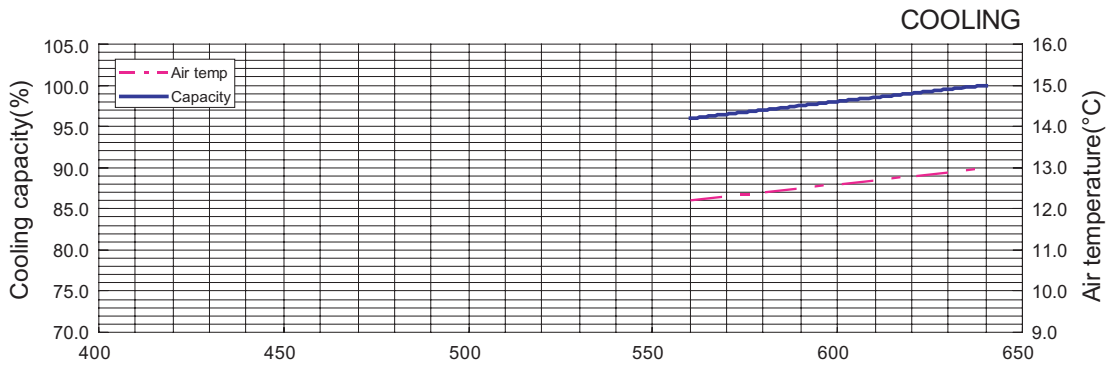
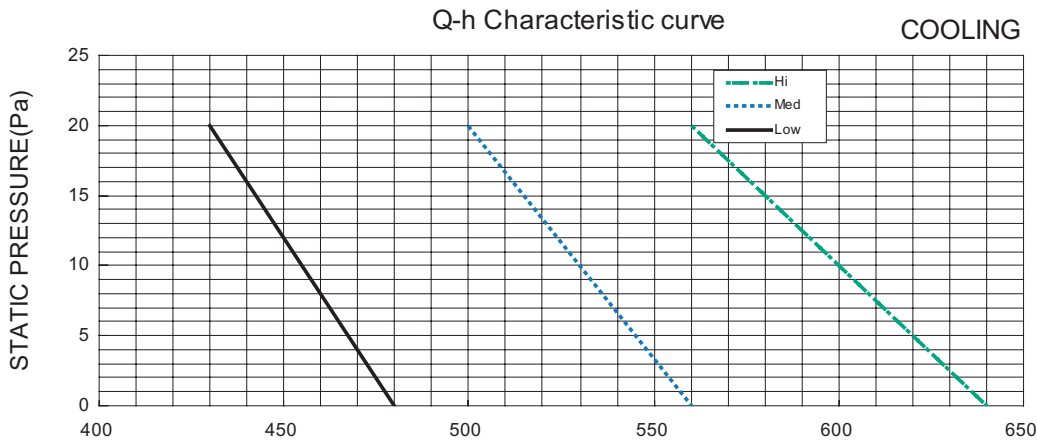

Test condition : No filter and Fan mode.

# MODELS : AR\*18F, AR\*18U

● 230V

DUCT TYPE  
AR7 - AR18K

230V		Static pressure (Pa)			
		0	40	70	
FAN SPEED	Hi	m <sup>3</sup> /h	1000	820	600
		l/s	278	228	167
		CFM	589	483	353
	Med	m <sup>3</sup> /h	900	750	570
		l/s	250	208	158
		CFM	530	441	335
	Low	m <sup>3</sup> /h	760	670	530
		l/s	211	186	147
		CFM	447	394	312

DUCT TYPE  
AR7 - AR18K

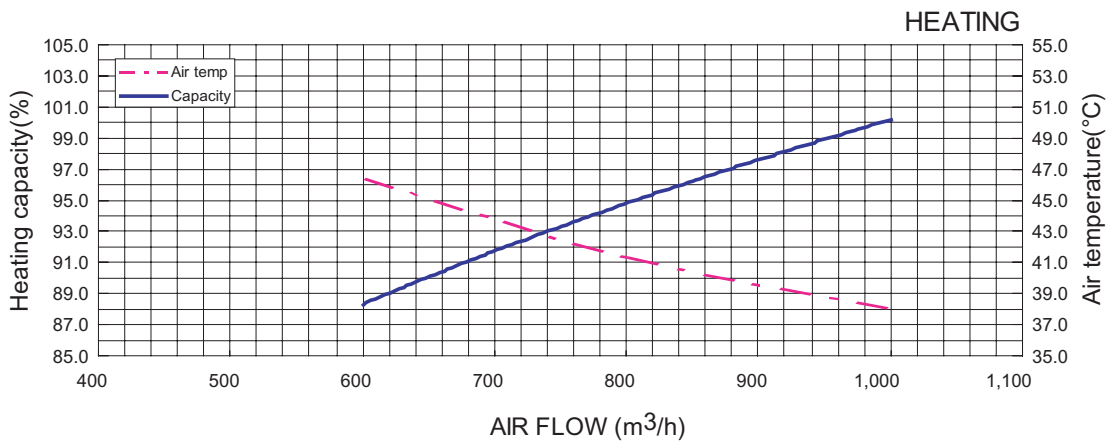
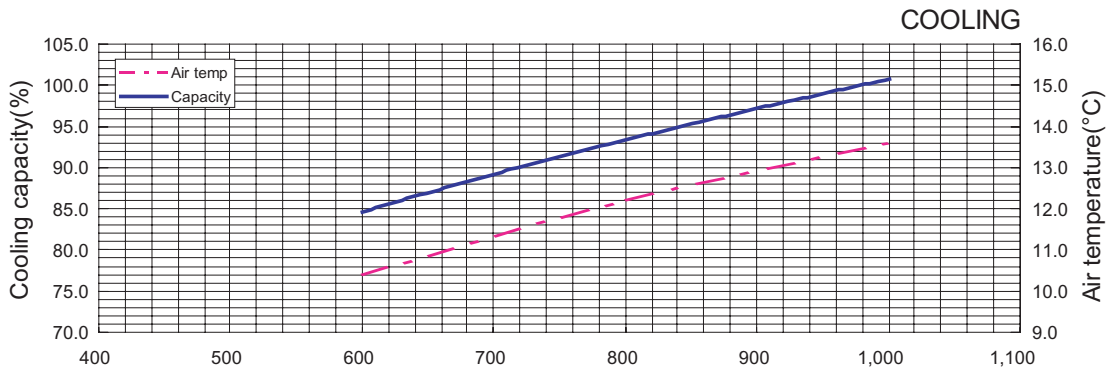
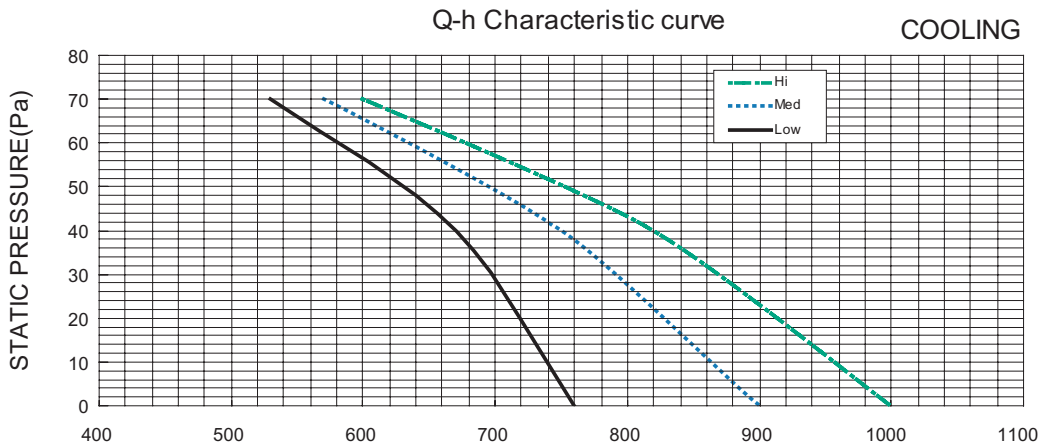

Test condition : No filter and Fan mode.

## 2-11-2. HIGH STATIC MODE

■ MODELS : AR\*7F, AR\*7U

● 230V

DUCT TYPE  
AR7 - AR18K

230V			Static pressure (Pa)	
			20	40
FAN SPEED	Hi	m <sup>3</sup> /h	340	290
		l/s	94	81
		CFM	200	171
	Med	m <sup>3</sup> /h	320	270
		l/s	89	75
		CFM	188	159
	Low	m <sup>3</sup> /h	300	250
		l/s	83	69
		CFM	177	147

DUCT TYPE  
AR7 - AR18K

Q-h Characteristic curve

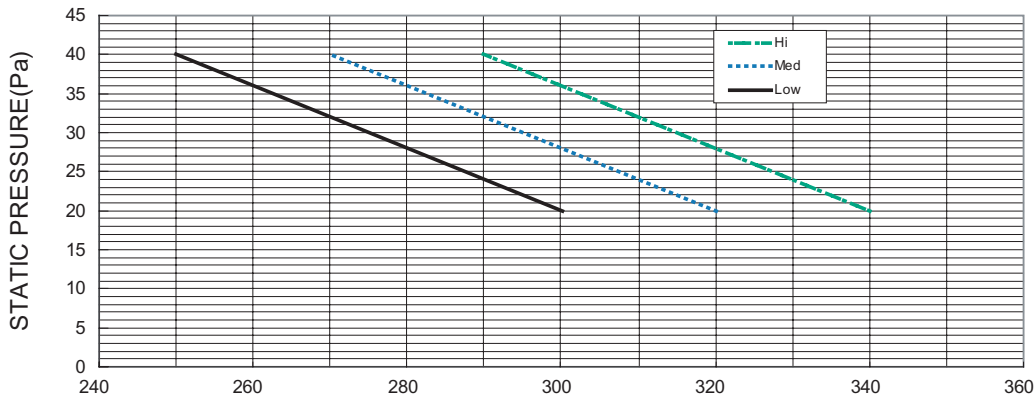

COOLING

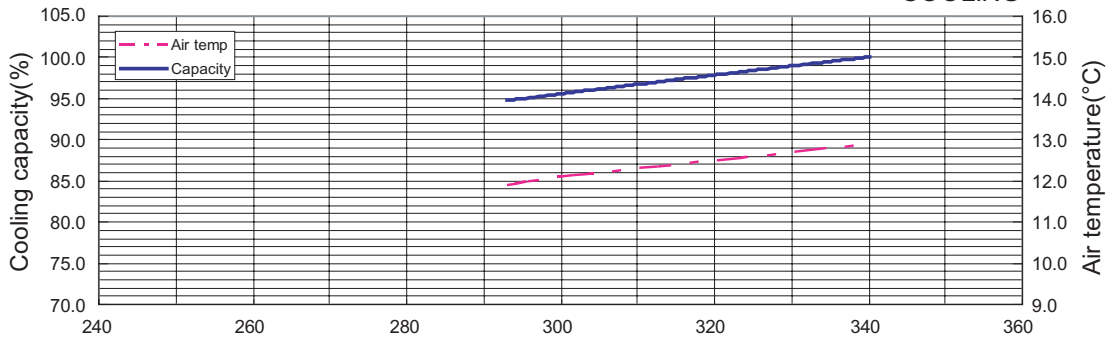

HEATING

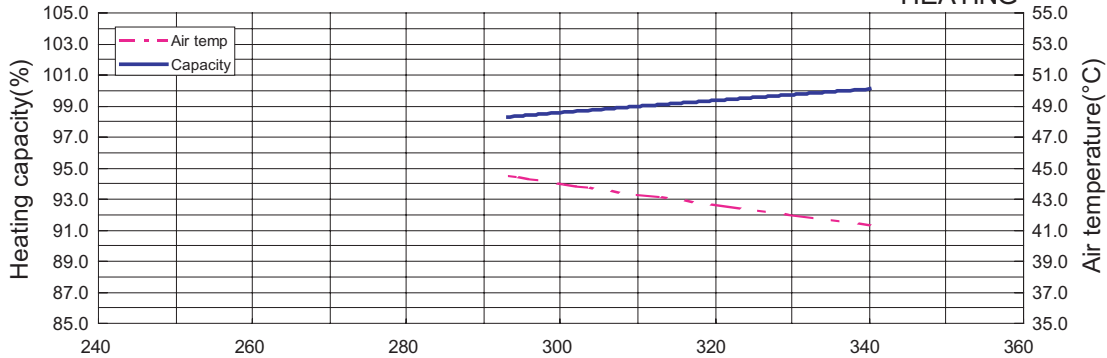

AIR FLOW (m<sup>3</sup>/h)

Test condition : No filter and Fan mode.

# MODELS : AR\*9F, AR\*9U

● 230V

DUCT TYPE  
AR7 - AR18K

DUCT TYPE  
AR7 - AR18K

230V			Static pressure (Pa)	
			20	40
FAN SPEED	Hi	m <sup>3</sup> /h	420	360
		l/s	117	100
		CFM	247	212
	Med	m <sup>3</sup> /h	390	330
		l/s	108	92
		CFM	230	194
	Low	m <sup>3</sup> /h	360	310
		l/s	100	86
		CFM	212	182

Q-h Characteristic curve

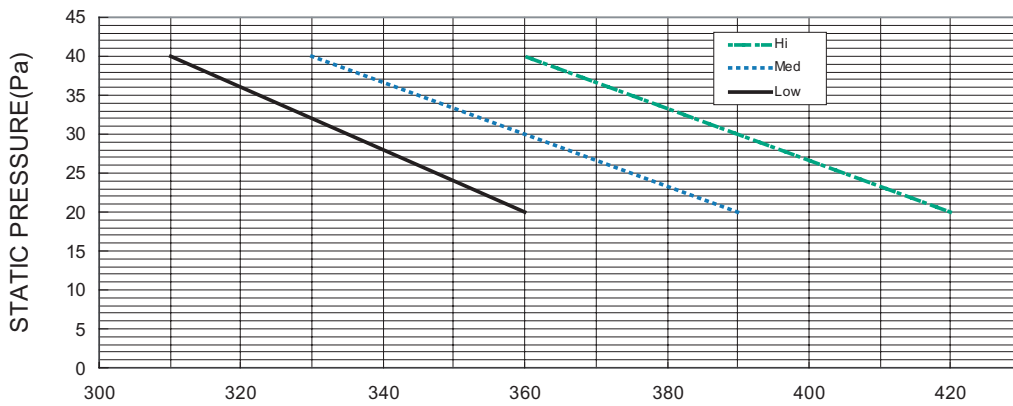

COOLING

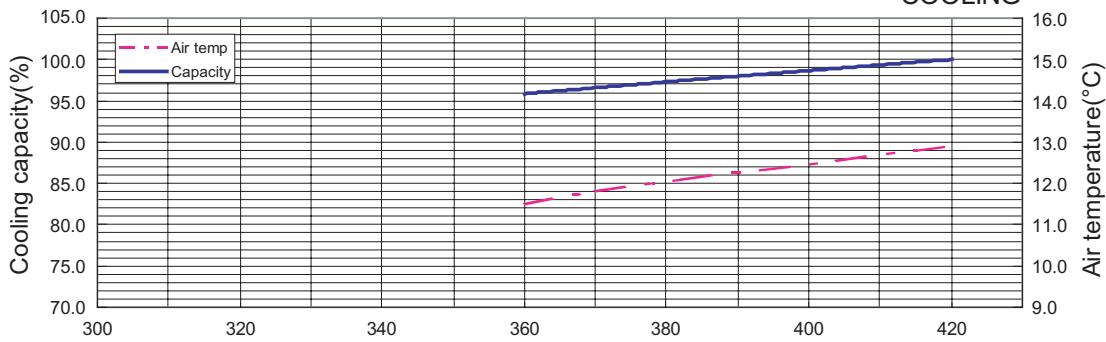

HEATING

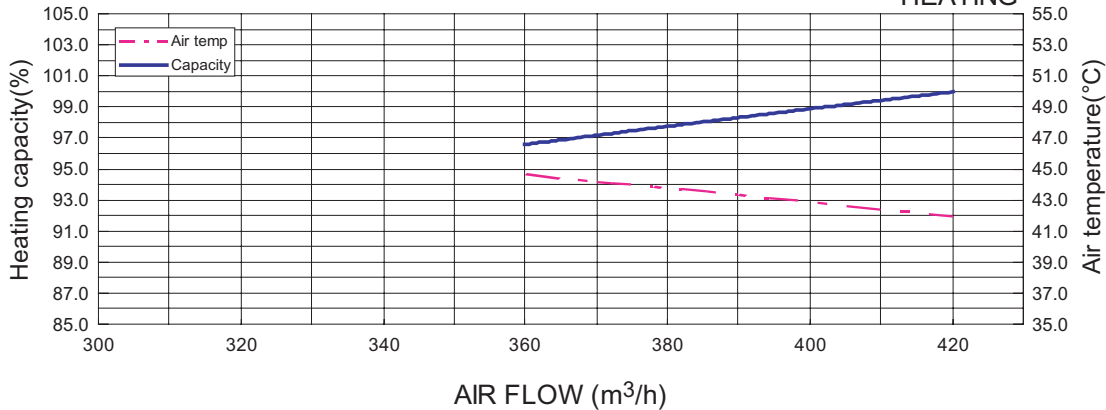

AIR FLOW (m<sup>3</sup>/h)

Test condition : No filter and Fan mode.

# MODELS : AR\*12F, AR\*12U

● 230V

DUCT TYPE  
AR7 - AR18K

230V			Static pressure (Pa)	
			20	40
FAN SPEED	Hi	m <sup>3</sup> /h	500	400
		l/s	139	111
		CFM	294	235
	Med	m <sup>3</sup> /h	450	370
		l/s	125	103
		CFM	265	218
	Low	m <sup>3</sup> /h	400	330
		l/s	111	92
		CFM	235	194

DUCT TYPE  
AR7 - AR18K

Q-h Characteristic curve

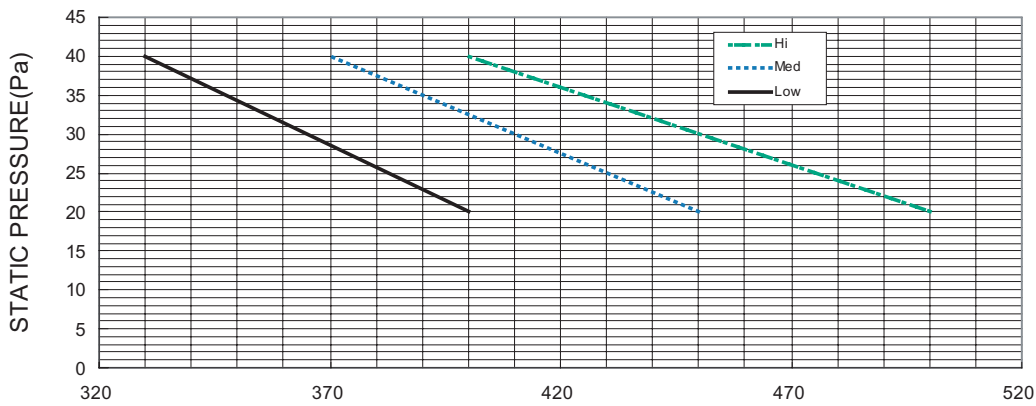

COOLING

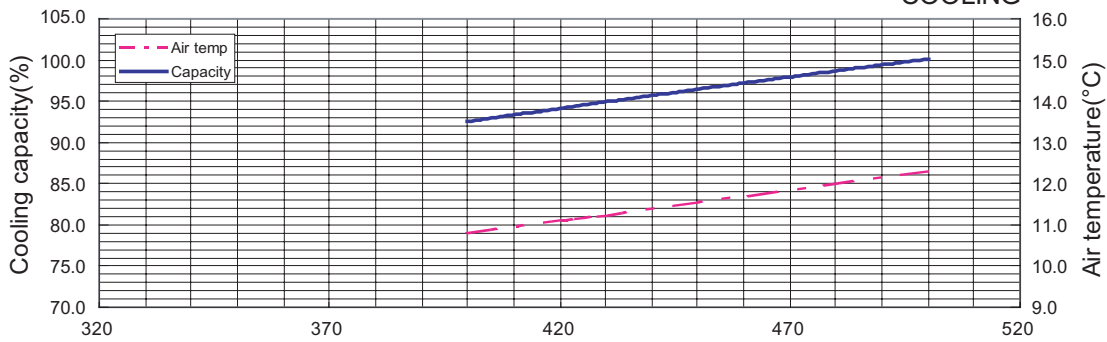

HEATING

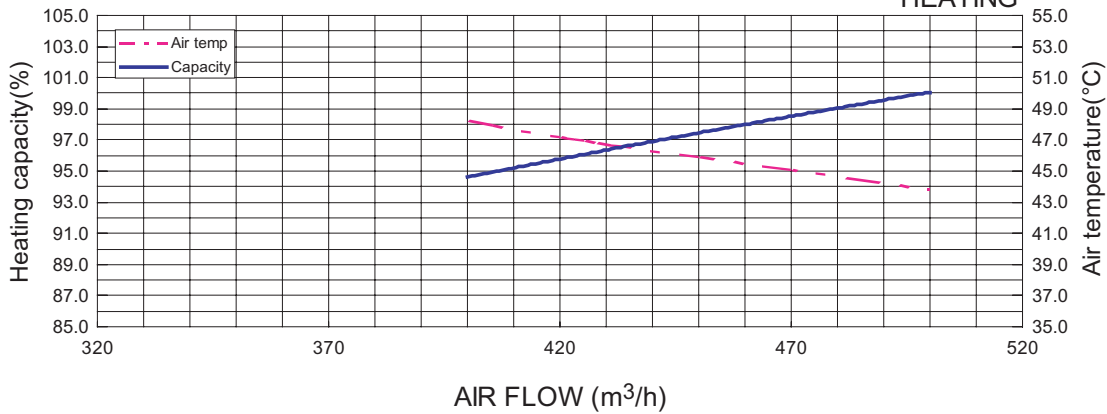

Test condition : No filter and Fan mode.



# MODELS : AR\*14F, AR\*14U

● 230V

DUCT TYPE  
AR7 - AR18K

DUCT TYPE  
AR7 - AR18K

230V			Static pressure (Pa)	
			20	40
FAN SPEED	Hi	m <sup>3</sup> /h	640	520
		l/s	178	144
		CFM	377	306
	Med	m <sup>3</sup> /h	560	470
		l/s	156	131
		CFM	330	277
	Low	m <sup>3</sup> /h	480	420
		l/s	133	117
		CFM	283	247

Q-h Characteristic curve

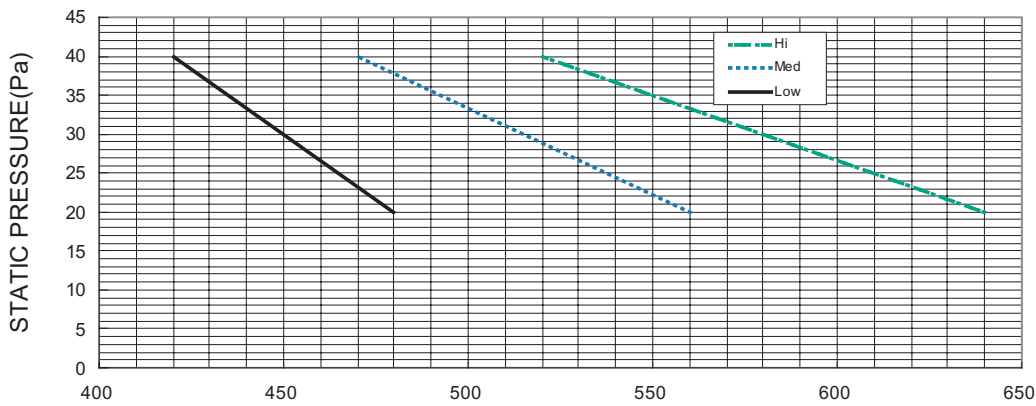

COOLING

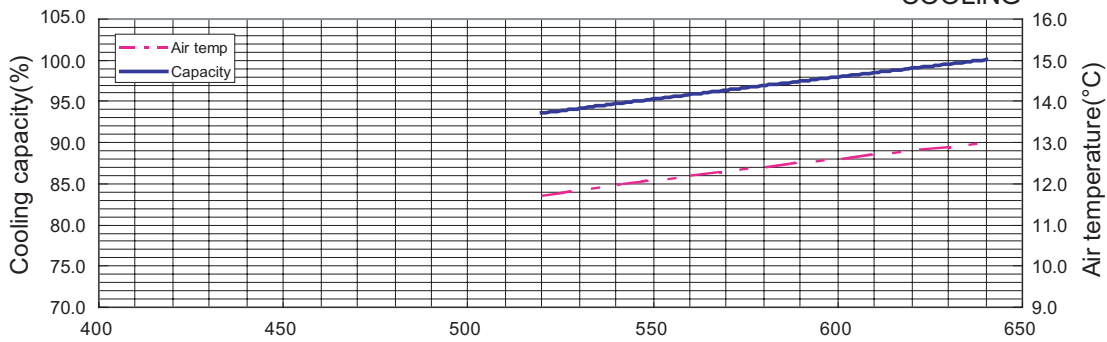

HEATING

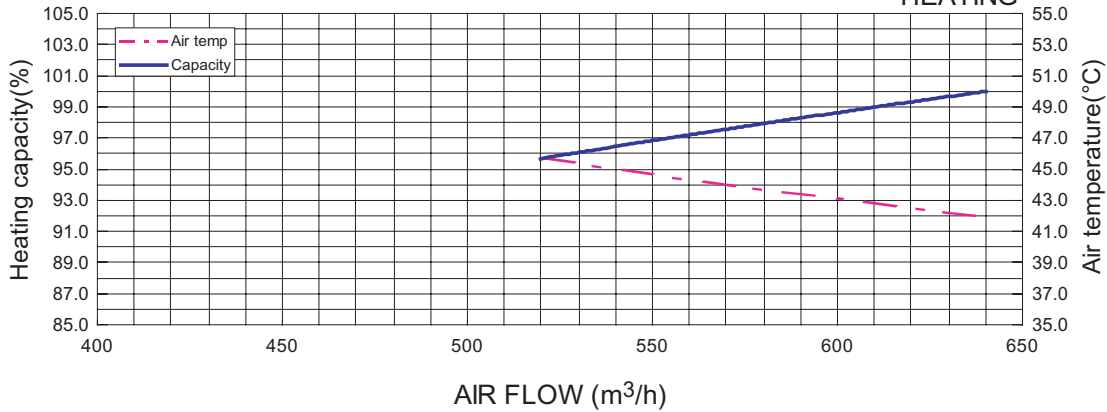

Test condition : No filter and Fan mode.

## 2-11-3. LOW STATIC MODE

■ MODELS : AR\*18F, AR\*18U

● 230V

DUCT TYPE  
AR7 - AR18K

230V			Static pressure (Pa)	
			0	40
FAN SPEED	Hi	m <sup>3</sup> /h	820	700
		l/s	228	194
		CFM	483	412
	Med	m <sup>3</sup> /h	750	650
		l/s	208	181
		CFM	441	383
	Low	m <sup>3</sup> /h	670	590
		l/s	186	164
		CFM	394	347

DUCT TYPE  
AR7 - AR18K

Q-h Characteristic curve

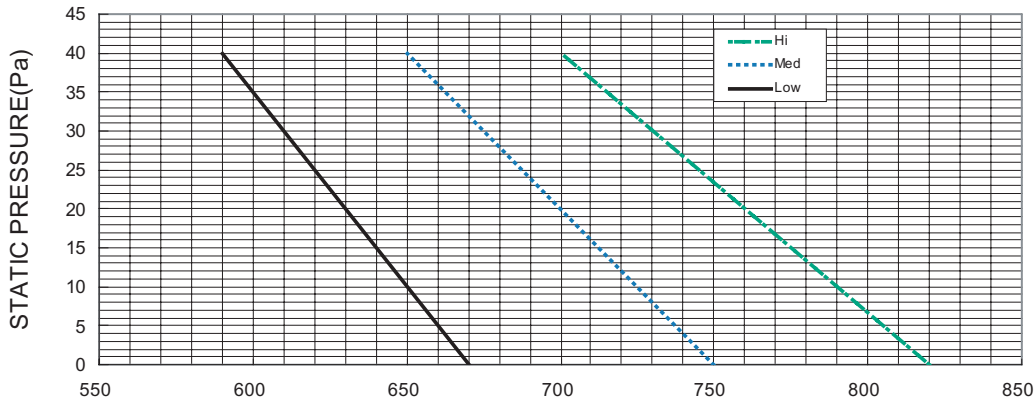

COOLING

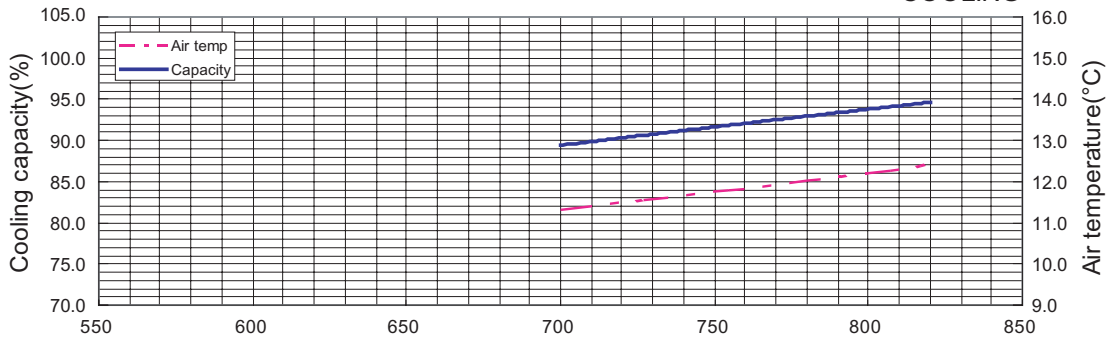

HEATING

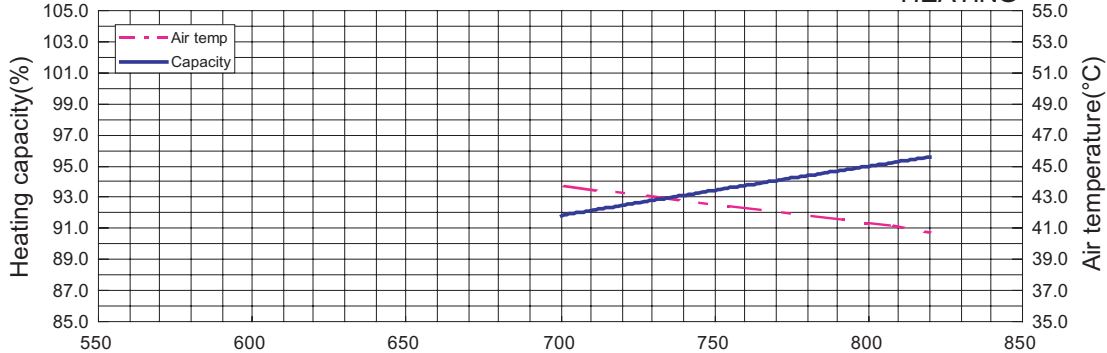

AIR FLOW (m<sup>3</sup>/h)

Test condition : No filter and Fan mode.

# 2-12. NOISE LEVEL CURVE

## 2-12-1. OUTDOOR UNIT

Condition  
Voltage : 230V /50Hz

DUCT TYPE  
AR7 - AR18K

### ■ COOLING

#### ● MODELS : AO\*7F, AO\*7U

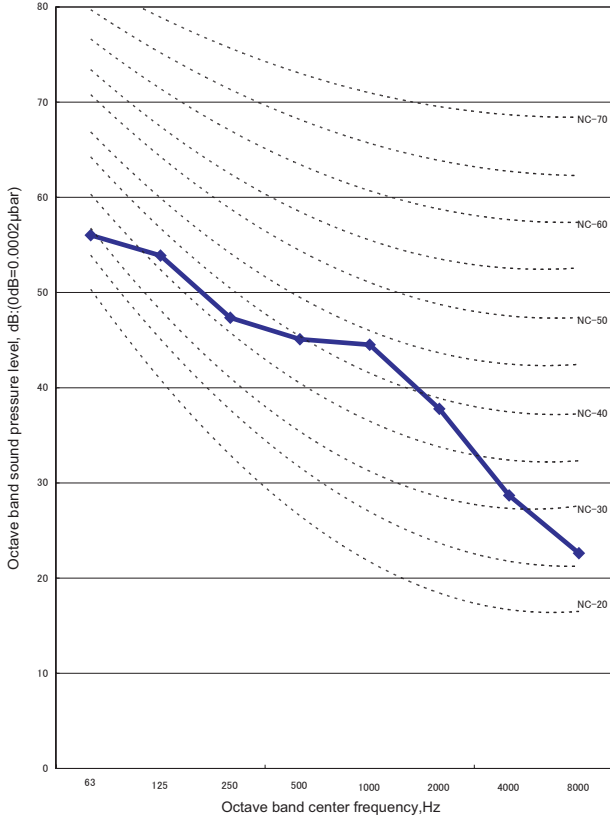

#### ● MODELS : AO\*9F, AO\*9U

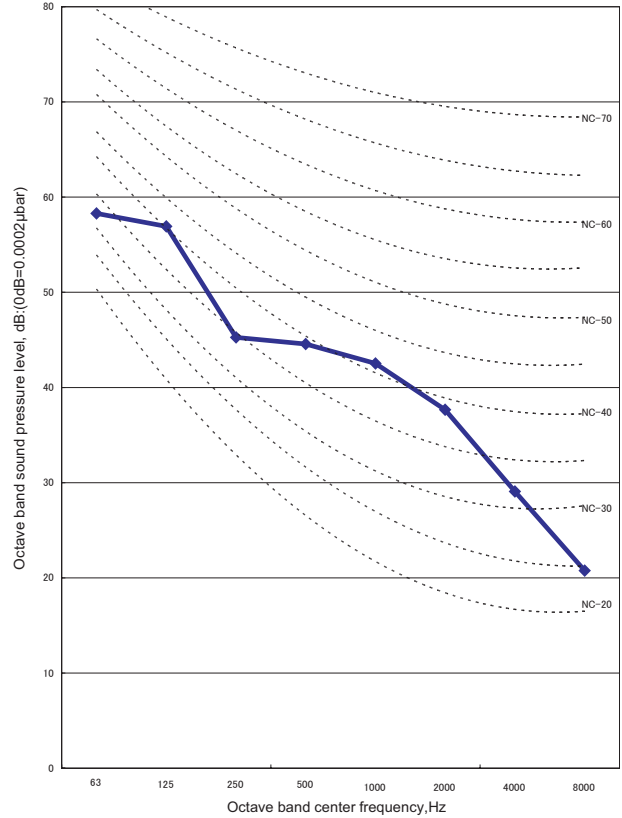

DUCT TYPE  
AR7 - AR18K

#### ● MODELS : AO\*12F, AO\*12U

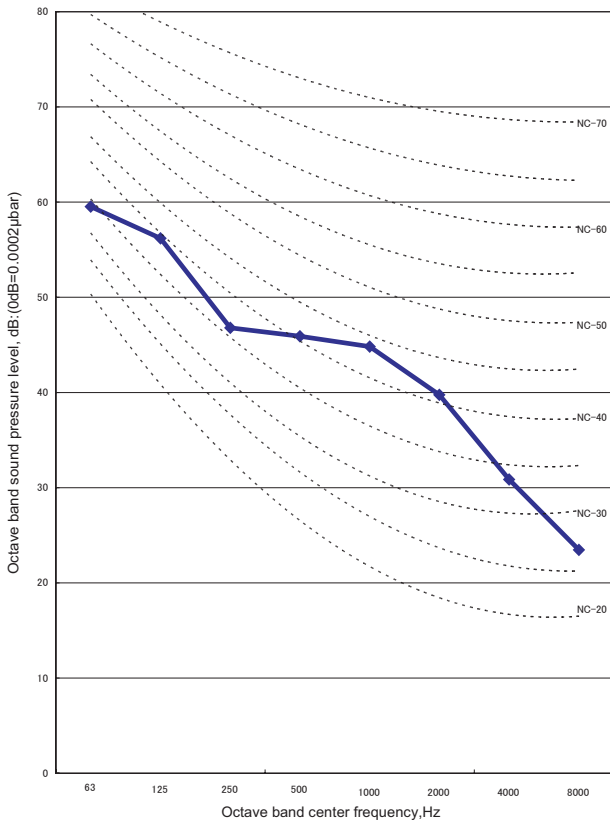

#### ● MODELS : AO\*14F, AO\*14U

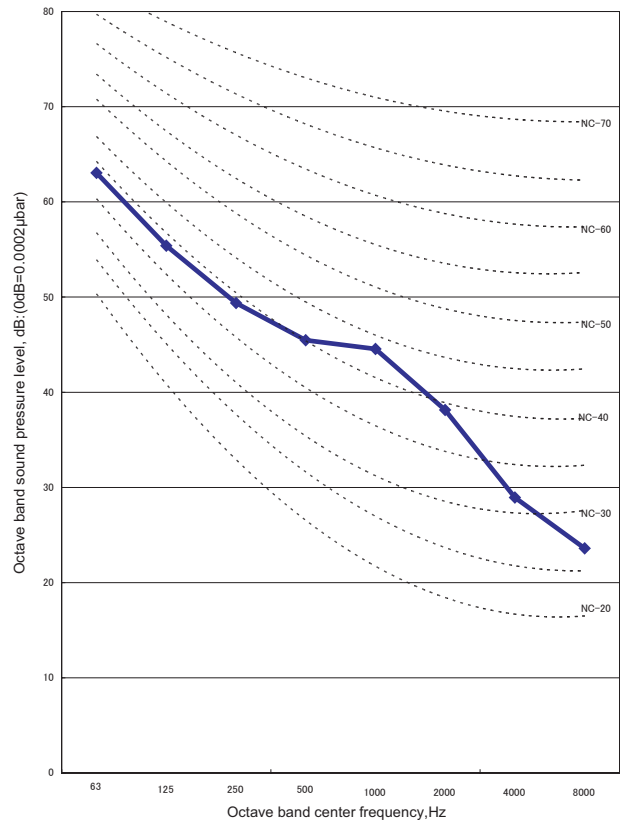

Condition  
Voltage : 230V /50Hz

DUCT TYPE  
AR7 - AR18K

DUCT TYPE  
AR7 - AR18K

### ■ COOLING

● MODELS : AO\*18F, AO\*18U

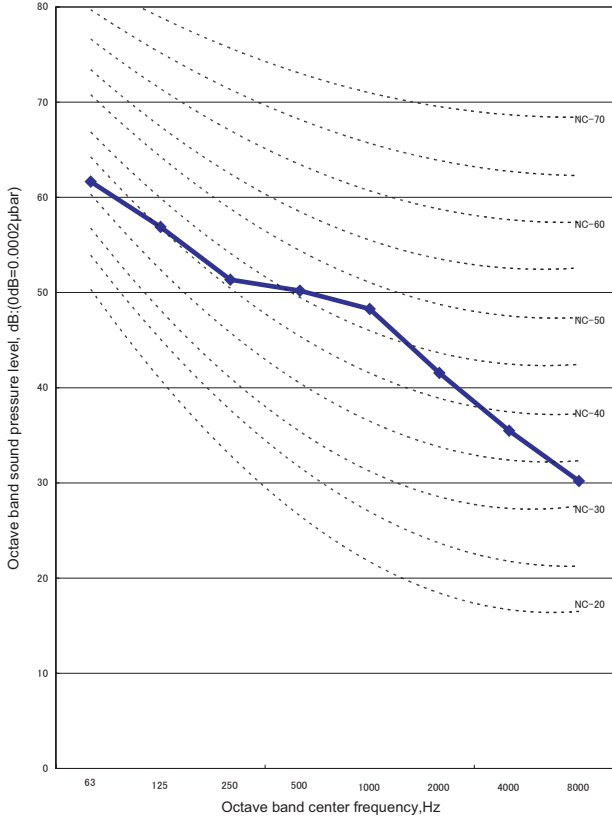

Condition  
Voltage : 230V /50Hz

DUCT TYPE  
AR7 - AR18K

## HEATING

### MODEL : AO\*7U

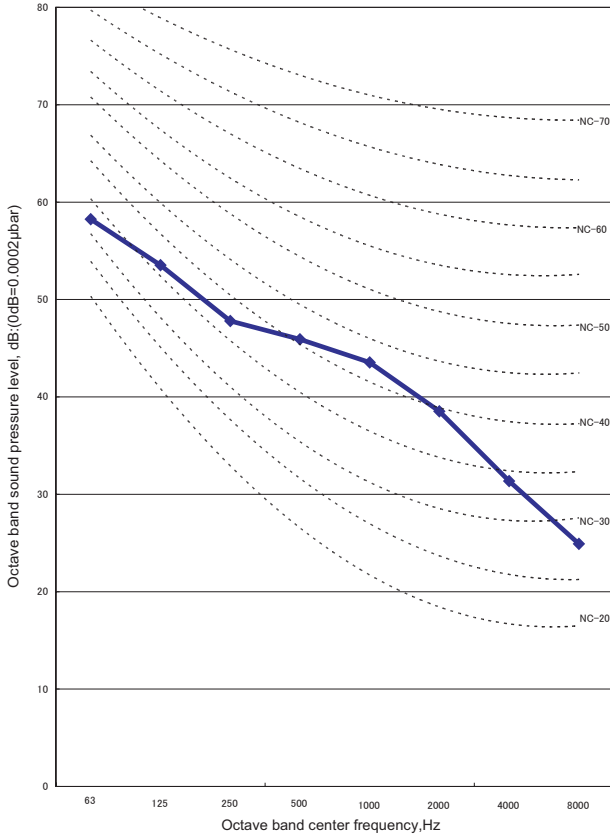

### MODEL : AO\*9U

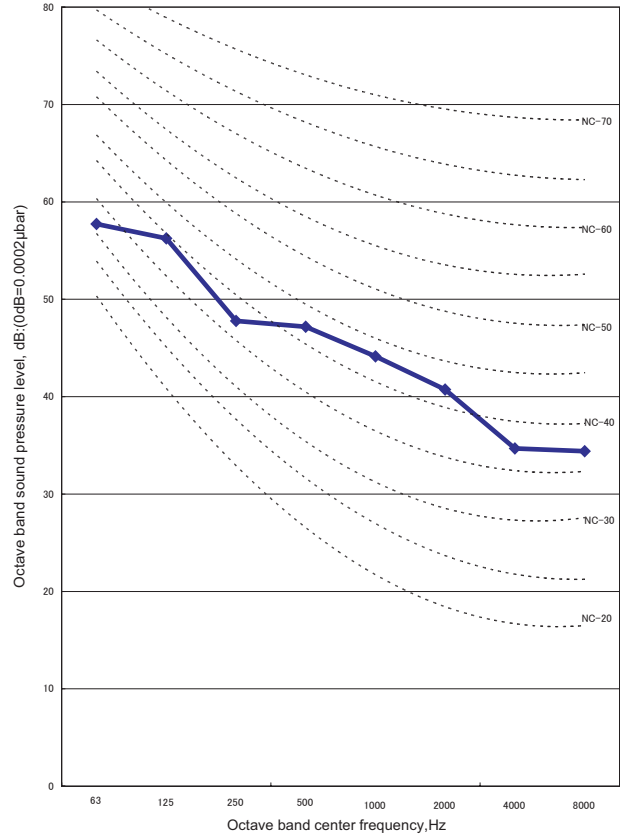

### MODEL : AO\*12U

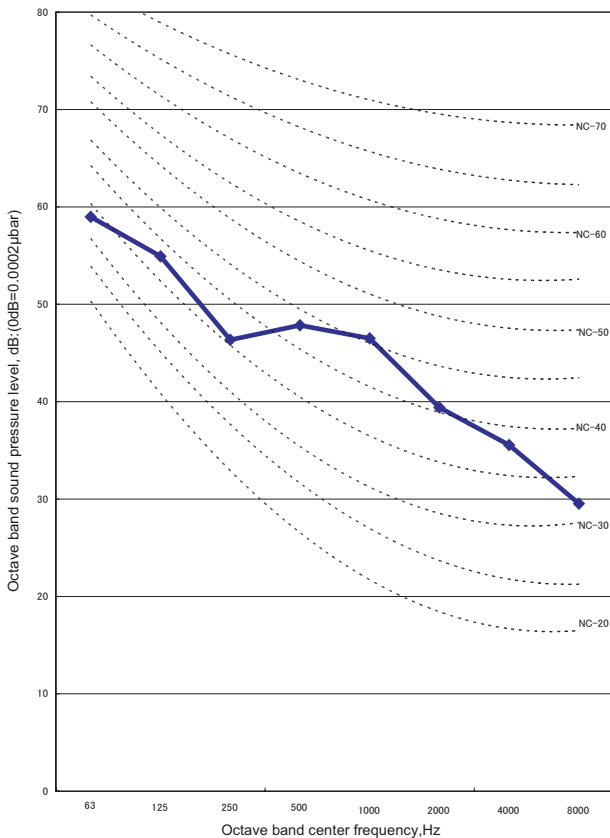

### MODEL : AO\*14U

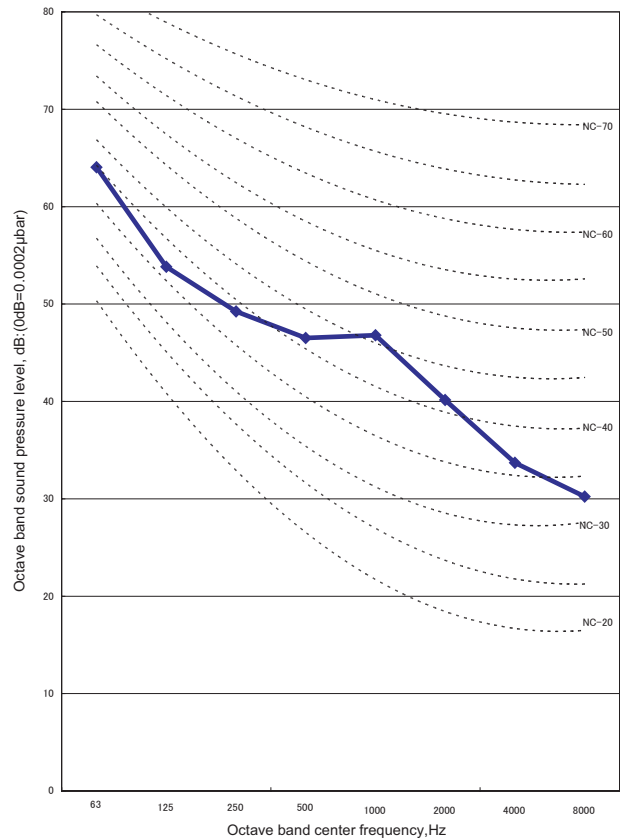

DUCT TYPE  
AR7 - AR18K

Condition  
Voltage : 230V /50Hz

DUCT TYPE  
AR7 - AR18K

DUCT TYPE  
AR7 - AR18K

## ■ HEATING

### ● MODEL : AO\*18U

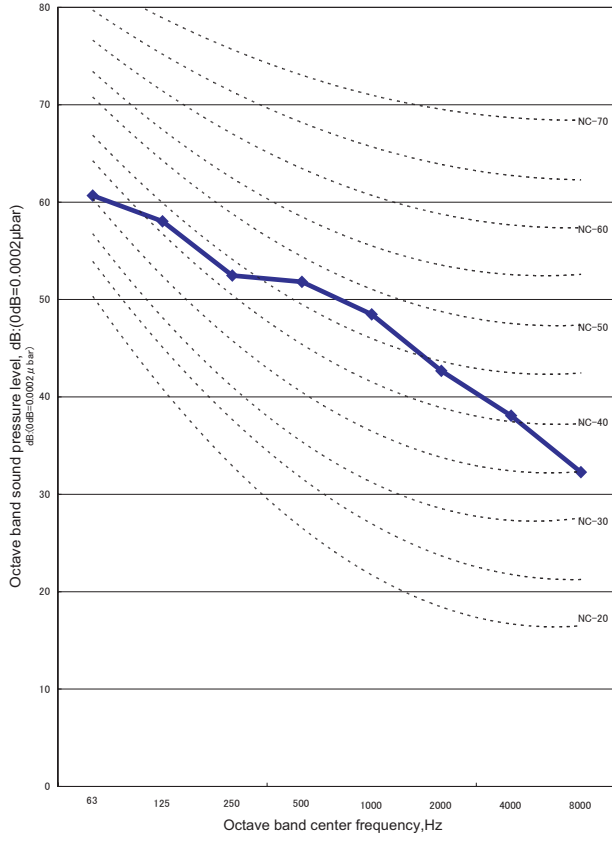

# 2-12-2. INDOOR UNIT

Condition  
 Fan speed : High,Low  
 Voltage : 230V /50Hz  
 Static pressure : 0Pa

DUCT TYPE  
AR7 - AR18K

DUCT TYPE  
AR7 - AR18K

## COOLING

### MODELS : AR\*7F,AR\*7U

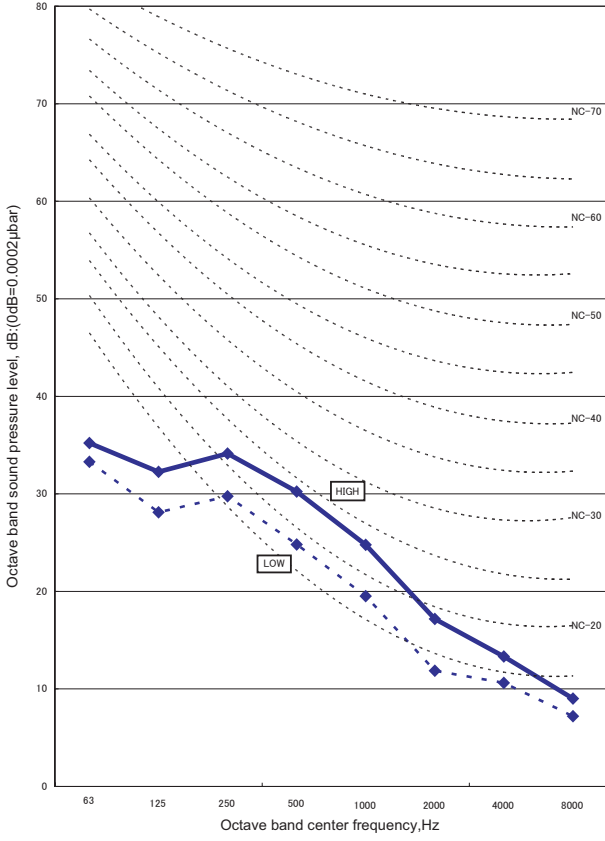

### MODELS : AR\*9F, AR\*9U

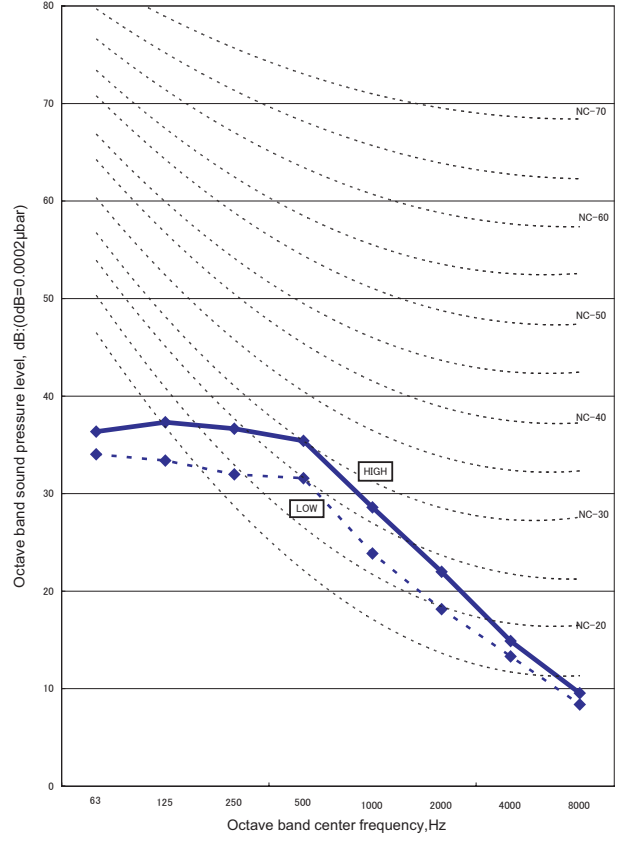

### MODELS : AR\*12F, AR\*12U

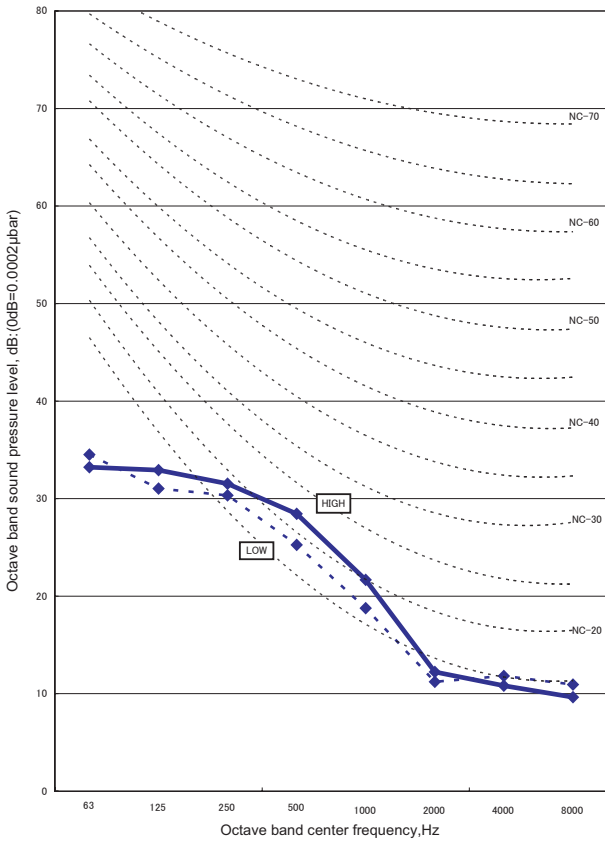

### MODELS : AR\*14F, AR\*14U

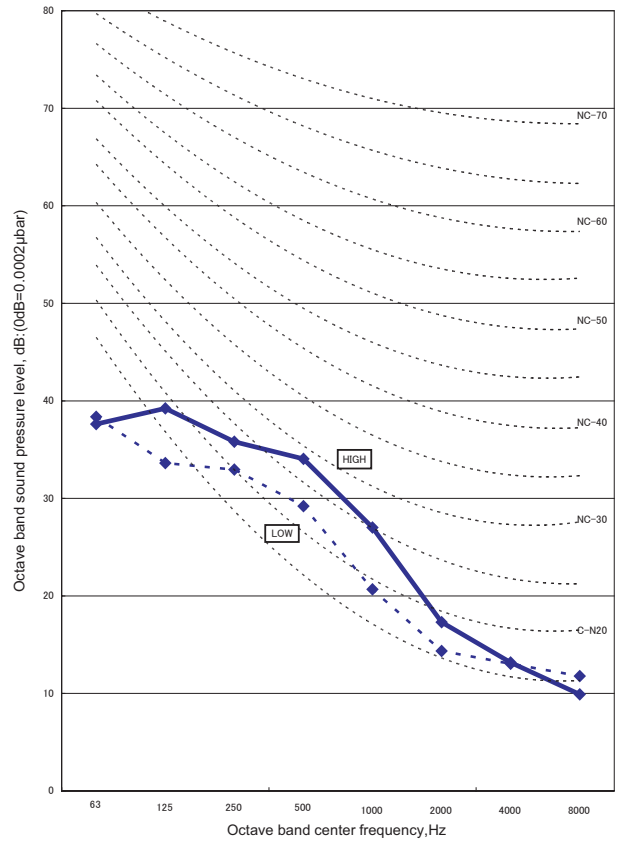

Condition  
Fan speed : High,Low  
Voltage : 230V /50Hz  
Static pressure : 0Pa

### COOLING

#### MODELS : AR\*18F, AR\*18U

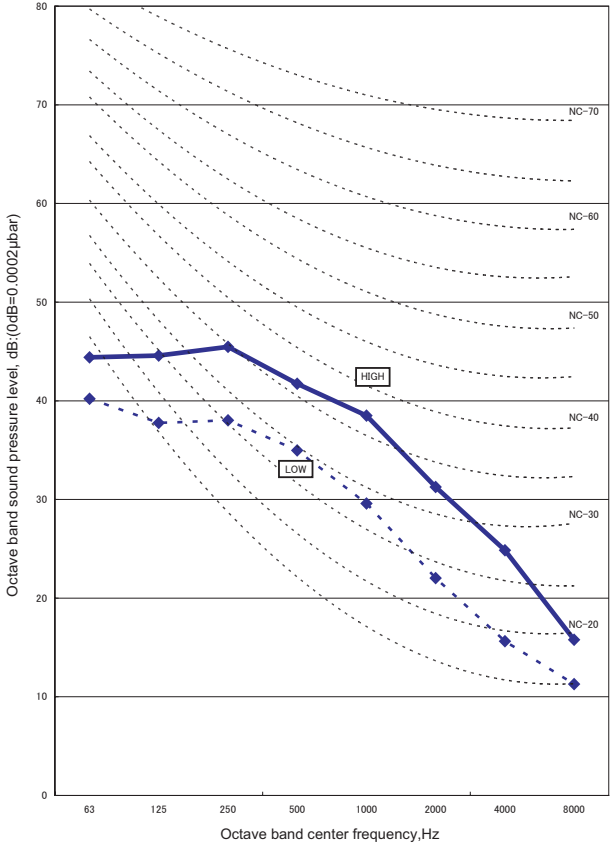



Condition	
Fan speed	: High, Low
Voltage	: 230V /50Hz
Static pressure	: 0Pa

## HEATING

● MODEL : AR\*7U

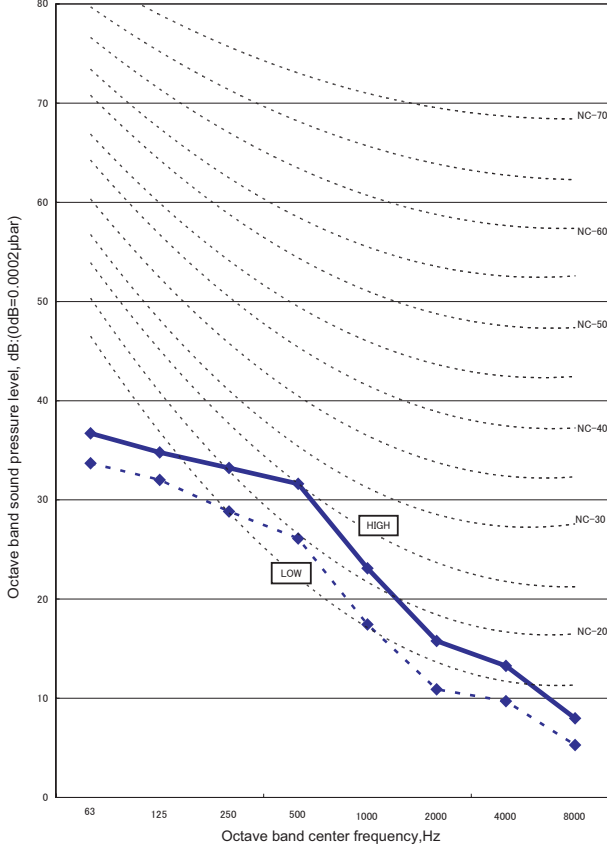

● MODEL : AR\*9U

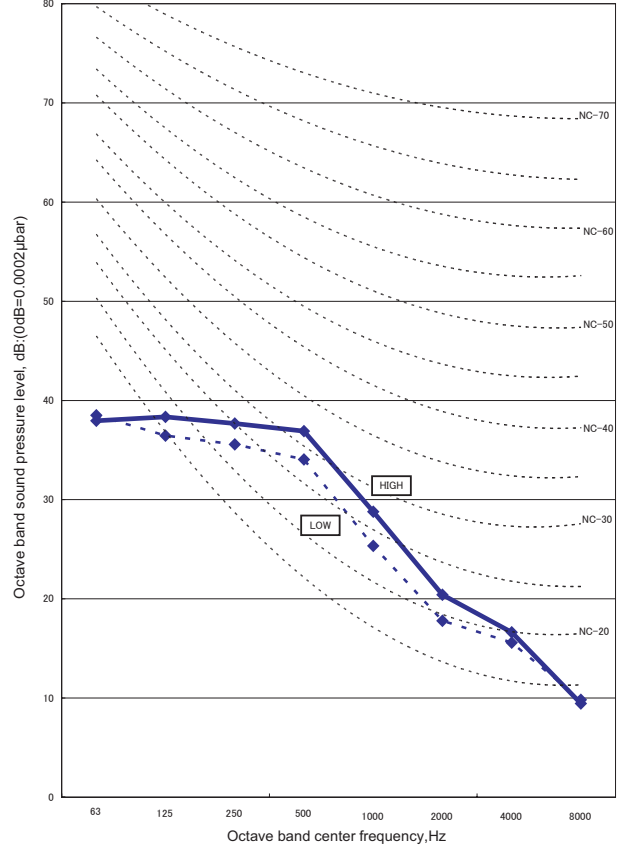

● MODEL : AR\*12U

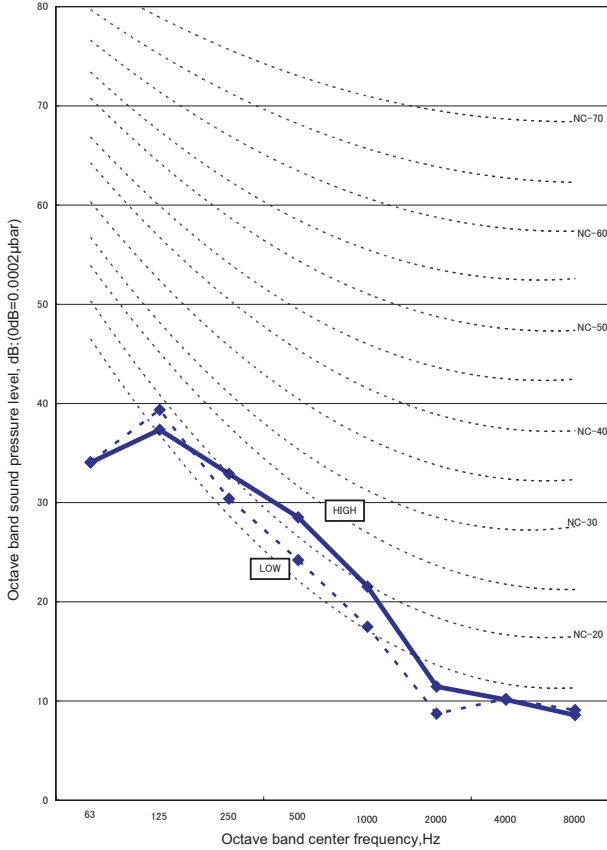

● MODEL : AR\*14U

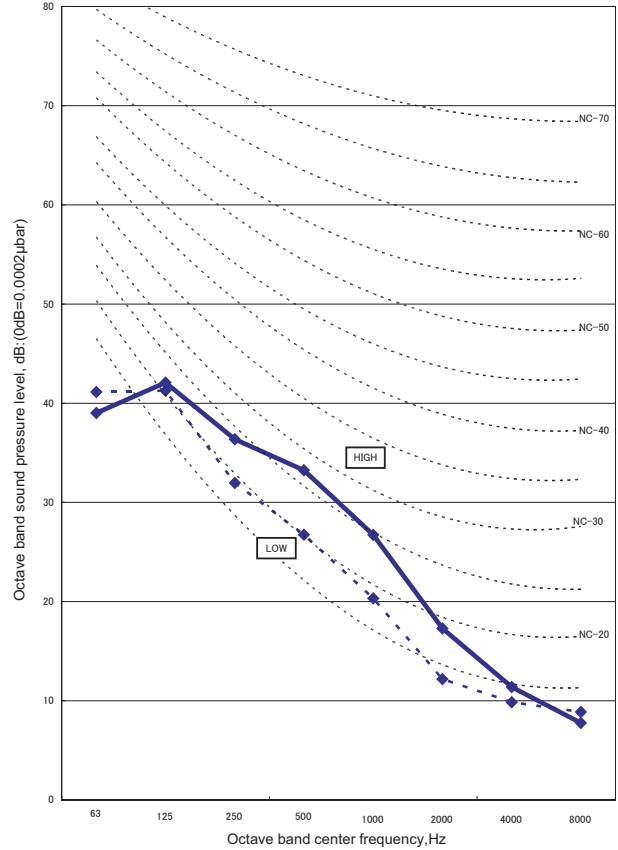

Condition  
 Fan speed : High, Low  
 Voltage : 230V /50Hz  
 Static pressure : 0Pa

**HEATING**

**MODEL : AR\*18U**

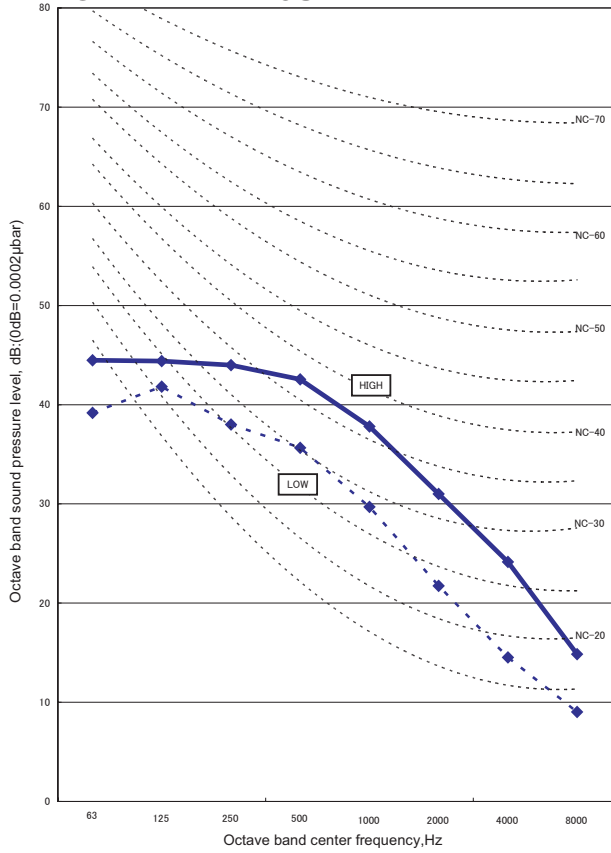

## ■ SOUND LEVEL CHECK POINT

### ● OUTDOOR UNIT

DUCT TYPE  
AR7 - AR18K

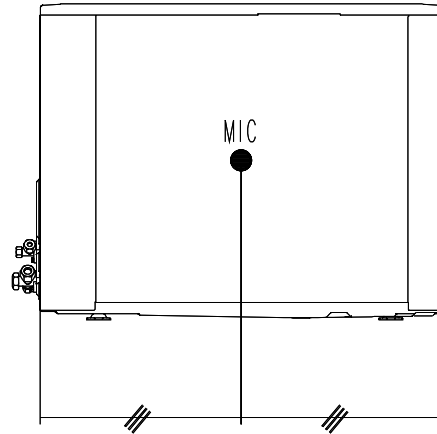
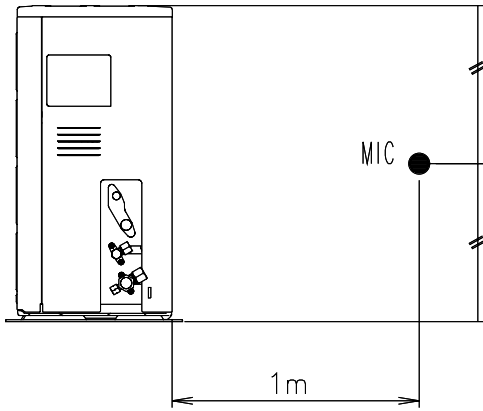

DUCT TYPE  
AR7 - AR18K

### ● INDOOR UNIT

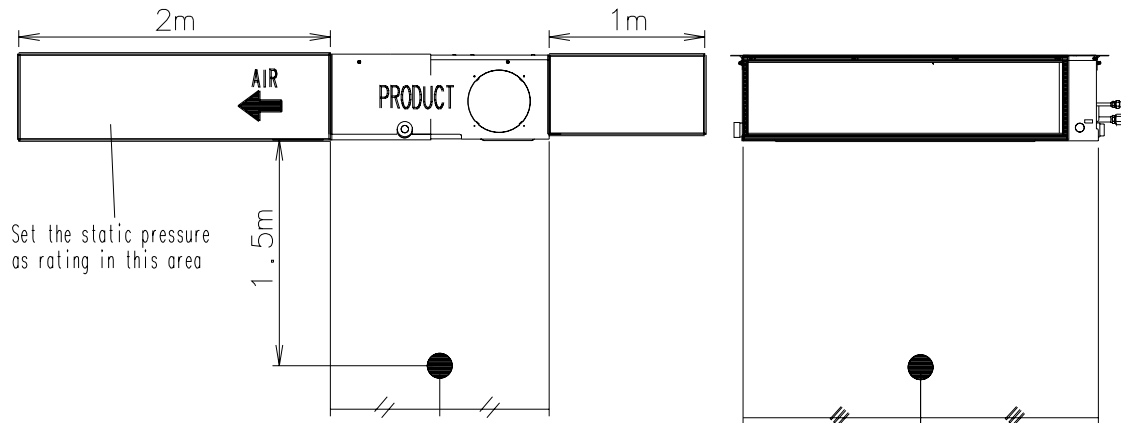

## 2-13. ELECTRIC CHARACTERISTICS

### ■ MODELS : AR\*7F / AO\*7F , AR\*9F / AO\*9F AR\*12F / AO\*12F , AR\*14F / AO\*14F

DUCT TYPE  
AR7 - AR18K

Model Name			AR*7F	AR*9F	AR*12F	AR*14F	AR*18F
			AO*7F	AO*9F	AO*12F	AO*14F	AO*18F
Power Supply	Voltage	V	230	230	230	230	230
		Hz	50	50	50	50	50
Rated Value	Mode		Cooling	Cooling	Cooling	Cooling	Cooling
	Current	A	3.7	4.6	5.5	6.3	9
	Input	kW	0.76	0.99	1.24	1.39	2.03
Max Operating Current		A	5.0	6.5	7.6	8.9	12.8
Starting Current		A	19.5	21	30	31	39
*1) Wiring Spec	MFA	A	10	10	15	15	20
	Power Cable	mm <sup>2</sup>	1.5	1.5	2.0	2.0	2.5
	*2)Limited wiring length	m	36	28	32	27	24
Indoor Fan Motor	Input	kW	0.035	0.044	0.030	0.045	0.970
	FLA	A	0.16	0.21	0.15	0.20	0.40
Outdoor Fan Motor	Input	kW	0.057	0.057	0.057	0.057	0.148
	FLA	A	0.24	0.24	0.24	0.24	0.73

DUCT TYPE  
AR7 - AR18K

### ■ MODELS : AR\*7U / AO\*7U , AR\*9U / AO\*9U AR\*12U / AO\*12U , AR\*14U / AO\*14U

Model Name			AR*7U		AR*9U		AR*12U		AR*14U		AR*18U	
			AO*7U		AO*9U		AO*12U		AO*14U		AO*18U	
Power Supply	Voltage	V	230		230		230		230		230	
		Hz	50		50		50		50		50	
Rated Value	Mode		Cooling	Heating	Cooling	Heating	Cooling	Heating	Cooling	Heating	Cooling	Heating
	Current	A	3.6	3.6	4.4	4.5	5.5	5.4	6.3	6.0	8.8	8.7
	Input	kW	0.76	0.76	0.96	0.96	1.24	1.21	1.42	1.35	1.92	1.87
Max Operating Current		A	5.1	5.2	6.1	6.2	7.6	7.5	9.2	8.3	12.3	12.0
Starting Current		A	19.5	19.5	21	21	30	30	31	31	39	39
*1) Wiring Spec	MFA	A	10		10		15		15		20	
	Power Cable	mm <sup>2</sup>	1.5		1.5		2.0		2.0		2.5	
	*2)Limited wiring length	m	36		29		32		26		25	
Indoor Fan Motor	Input	kW	0.035		0.044		0.030		0.045		0.970	
	FLA	A	0.16		0.21		0.15		0.20		0.40	
Outdoor Fan Motor	Input	kW	0.057		0.057		0.057		0.057		0.148	
	FLA	A	0.23		0.23		0.23		0.23		0.73	

\*1) Wiring Spec : Selected Sample (Selected based on Japan Electrotechnical Standard and Codes Committee E0005)

\*2) Limited Wiring length : This is the wiring length in case voltage descent is less than 2%.

When the wiring length becomes long, please select the wiring of a more larger diameter.

MFA: Main Fuse (Circuit breaker) Current

FLA: Full Load Amp.

## 2-14. SAFETY DEVICE

### ■ COOLING MODEL

#### ● OUTDOOR UNIT

MODEL NAME	PROTECTION FORM	AO*7F	AO*9F	AO*12F	AO*14F	AO*18F
FAN MOTOR PROTECTOR	THERMAL PROTECTOR	140°C±5°C OFF	140°C±5°C OFF	140°C±5°C OFF	140°C±5°C OFF	150°C±5°C OFF
COMPRESSOR	-	OFF 150±5°C (16.5A/25°C) (6A/80°C) ON 69±11°C	OFF 145±5°C (16.5A/25°C) (7A/80°C) ON 69±11°C	OFF 150±5°C (23.5A/25°C) (9.6A/80°C) ON 69±11°C	OFF 160±5°C (25.5A/25°C) (10.7A/80°C) ON 69±11°C	OFF 150±5°C (30A/25°C) (13A/80°C) ON 69±11°C

#### ● INDOOR UNIT

MODEL NAME	PROTECTION FORM	AR*7F	AR*9F	AR*12F	AR*14F	AR*18F
PCB FUSE	-	3.15A 250V	3.15A 250V	3.15A 250V	3.15A 250V	3.15A 250V
FAN MOTOR PROTECTOR	THERMAL PROTECTOR	150°C±5°C OFF	150°C±5°C OFF	150°C±5°C OFF	150°C±5°C OFF	150°C±5°C OFF

### ■ HEAT PUMP MODEL

#### ● OUTDOOR UNIT

MODEL NAME	PROTECTION FORM	AO*7U	AO*9U	AO*12U	AO*14U	AO*18U
FUSE (SIDE OF POWER SUPPLY)	-	-	-	-	-	-
FUSE ON MAIN PCB	-	-	-	-	-	3.15A 250V
FAN MOTOR PROTECTOR	THERMAL PROTECTOR	140°C±5°C OFF	140°C±5°C OFF	140°C±5°C OFF	140°C±5°C OFF	150°C±5°C OFF
COMPRESSOR	-	OFF 150±5°C (16.5A/25°C) (6A/80°C) ON 69±11°C	OFF 145±5°C (16.5A/25°C) (7A/80°C) ON 69±11°C	OFF 150±5°C (23.5A/25°C) (9.6A/80°C) ON 69±11°C	OFF 160±5°C (25.5A/25°C) (10.7A/80°C) ON 69±11°C	OFF 150±5°C (30A/25°C) (13A/80°C) ON 69±11°C

#### ● INDOOR UNIT

MODEL NAME	PROTECTION FORM	AR*7U	AR*9U	AR*12U	AR*14U	AR*18U
PCB FUSE	-	3.15A 250V	3.15A 250V	3.15A 250V	3.15A 250V	3.15A 250V
FAN MOTOR PROTECTOR	THERMAL PROTECTOR	150°C±5°C OFF	150°C±5°C OFF	150°C±5°C OFF	150°C±5°C OFF	150°C±5°C OFF

## 2-15. EXTERNAL INPUT & OUTPUT

### ■ FRESH AIR OUTPUT SETTING

You can control sub fan by synchronizaton with fan operation of indoor unit.

[Example]

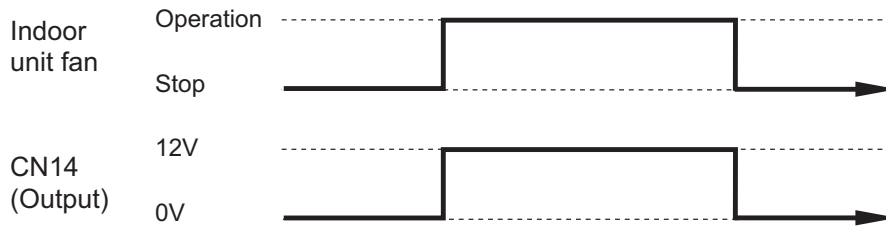
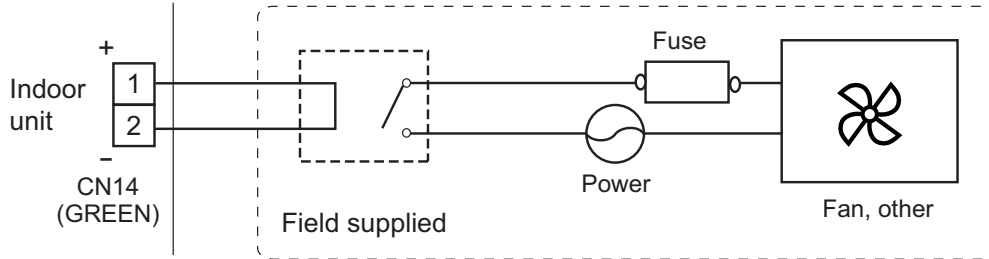

## EXTERNAL ELECTRICAL HEATER OUTPUT SETTING

You can control Electrical heater (Booster) by synchronization with heating operation.  
 When temperature is -10 to -3 degrees from Setpoint, External electrical heater is ON.  
 When temperature is -1 degrees from Setpoint, External electrical heater Stops.

### ● Jumper wire (Indoor Unit)

This is used to continue indoor unit fan operation for 1 minute after thermo OFF in heating mode.  
 1 minute delay control set by cutting JM3 on PCB.

#### [Example]

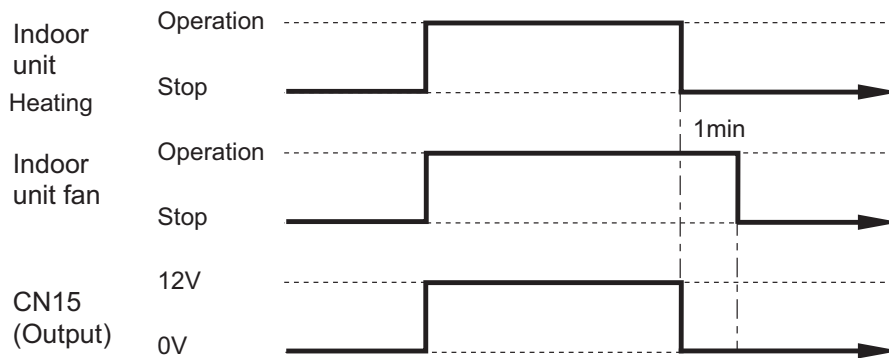
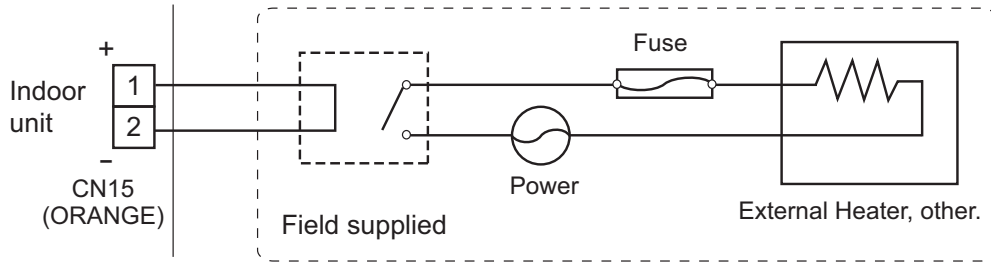

**⚠ CAUTION!**

Please locate external a heater between the indoor unit and the ductwork.  
 Please be sure to use delay control of a fan.

## 2-16. FUNCTION SETTING

### 2-16-1. INDOOR UNIT

DUCT TYPE  
AR7 - AR18K

INDOOR UNIT			
DIP SW	SW 1	1	Auto restart validity/invalidity
		2	Room temperature correct coefficient of heating
		3	Room temperature correct coefficient of heating
	SW 4	1	Forbidden
		2	High(Low) static pressure function setting
		3	Fan delay setting
Rotary SW	SW 2		Indoor unit number setting
Jumper Wire		JM1	Forbidden
		JM2	Forbidden
		JM3	Forbidden

DUCT TYPE  
AR7 - AR18K

#### ■ SWITCH POSITION

##### ● Indoor unit control circuit board

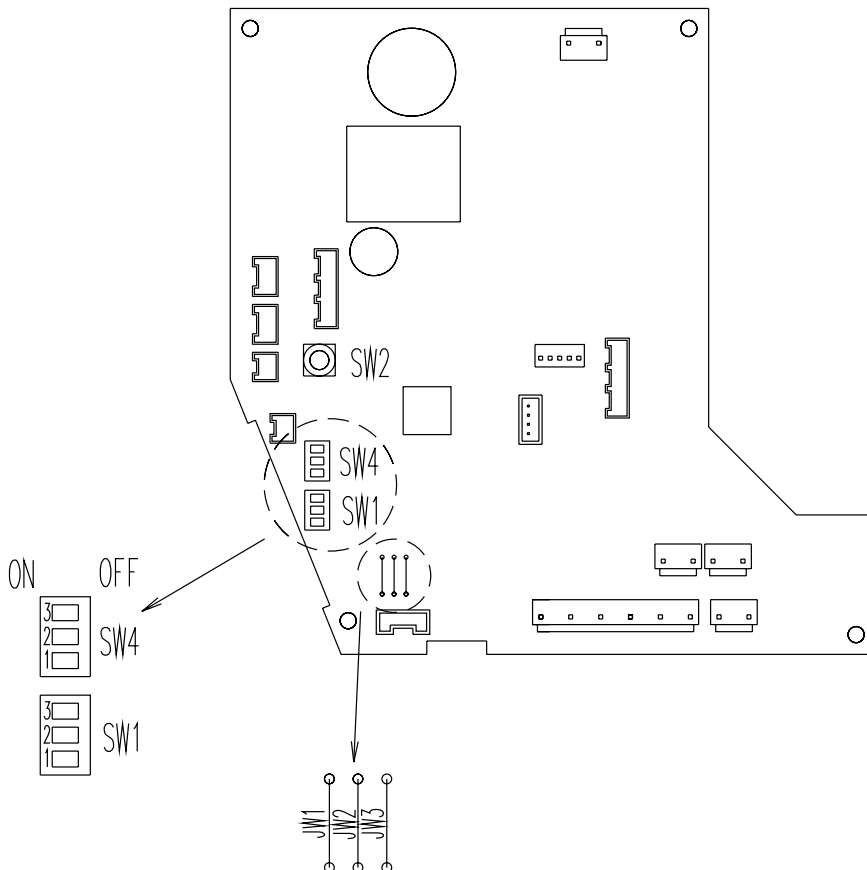



## 2-16-2. SWITCH FUNCTION (INDOOR UNIT)

### ■ DIP SWITCH SETTING

#### 1-1.Auto restart setting

Auto restart function can be selected by turning this switch ON/OFF.

AUTO RESTART SETTING (◆ . . . Factory setting)

SW 1-1	SW state
OFF	Invalidity
◆ ON	Validity

#### 1-2.Room temperature correct coefficient of heating.

Decide the heating temperature correct coefficient vale of heating.

HEAT TEMPERATURE CORRECTION (◆ . . . Factory setting)

SW 1-2	SW 1-3	SW state
OFF	OFF	+2 deg
ON	OFF	-2 deg
OFF	ON	0 deg (Floor setting)
◆ ON	ON	+4 deg (Ceiling setting)

#### 4-1.Dip SW 4-1setting forbidden

(◆ . . . Factory setting)

◆ SW 4-1	OFF
----------	-----

#### 4-2.High(Low) static pressure function setting

In case of installing in high(low) static, you can maximize(minimize) air flow and noise.

Model:AR\*7 to 14 (◆ . . . Factory setting)

SW 4-2	SW state
◆ OFF	Normal
ON	High static pressure

Model:AR\*18 (◆ . . . Factory setting)

SW 4-2	SW state
◆ OFF	Normal
ON	Low static pressure

#### 4-3.Fan delay setting

This setting can be used when the auxiliary heater is mounted.

When the fan operation is stopped when the indoor unit is operating with an auxiliary heater, the fan operation continues one minutes

(◆ . . . Factory setting)

SW 4-3	SW state
◆ OFF	Invalidity
ON	Validity

## ■ ROTARY SWITCH SETTING

This switch can be used when group control system.  
Set the indoor unit address in the 1,2,-,15 order.

(◆ . . . Factory setting)

◆ SW 2	SW state
0	Single
1 - 15	Indoor unit address

## ■ JUMPER WIRE SETTING

1-1.JM 1, 2, 3 setting forbidden

(◆ . . . Factory setting)

◆ JM 1, 2, 3	SW state
Connect	Forbidden
Disconnect	

## ■ EXTERNAL INPUT AND OUTPUT

(◆ . . . Factory setting)

Connector	INPUT	OUTPUT	REMARKS
CN10	-	ELECTRICAL HEATER	See external input/output settings for details.
CN11	-	FRESH AIR	

## 2-16-3. WIRED, SIMPLE REMOTE CONTROLLER CIRCUIT BOARD

DUCT TYPE  
AR7 - AR18K

Wired, Simple remote controller		
DIP SW	1	Dual remote controller setting
	2	
	3	Group control setting
	4	Model setting
	5	Auto changeover setting
	6	Memory backup setting

DUCT TYPE  
AR7 - AR18K

### ■ SWITCH POSITION

#### ● Wired remote controller

Front case (back side)

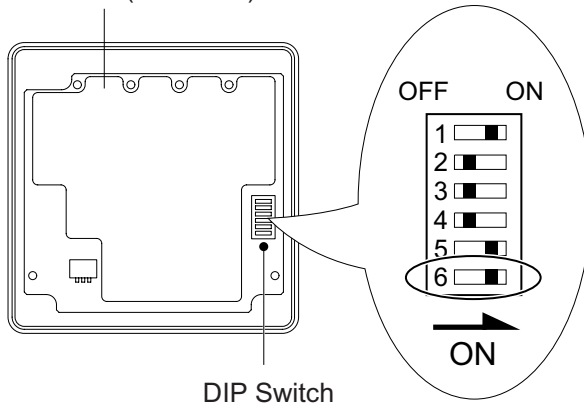

#### ● Simple remote controller

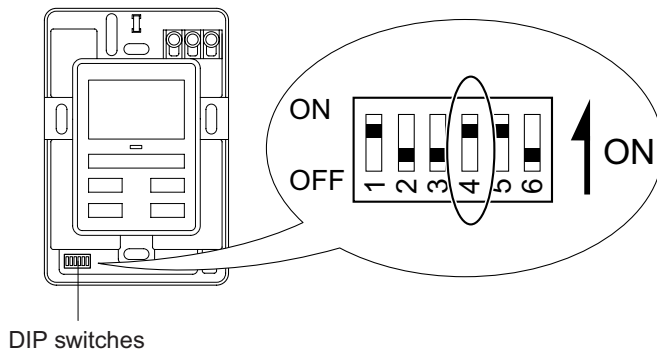

## 2-16-4. WIRED, SIMPLE REMOTE CONTROLLER

### ■ DIP SWITCH SETTING

#### 1. SW setting

##### 1-1 Dual remote controller setting

Set the remote controller DIP switch No.1 and 2 according to the following table.

(◆ . . . Factory setting)

Number of remote controller	Master unit		Slave unit	
	DIP-SW No.1	DIP-SW No.2	DIP-SW No.1	DIP-SW No.2
◆ 1 (Normal)	ON	OFF	—	—
2 (Dual)	OFF	OFF	ON	ON

##### 1-2 Group control setting

Number of indoor unit connection (One/Multiple)

This is switched according to the number of connected indoor units.

(◆ . . . Factory setting)

DIP-SW No.3	Number of indoor unit
◆ OFF	One unit connection
ON	Multiple unit connection

##### 1-3 Model setting

The system type of the outdoor unit can be selected by setting up DIP switch No.4 as follows.

(◆ . . . Factory setting)

DIP-SW No.4	Model
◆ OFF	Heat Pump model
ON	Cooling only model

##### 1-4 Auto changeover setting

Selecting auto changeover validity / invalidity.

(◆ . . . Factory setting)

DIP-SW No.5	Auto changeover
◆ OFF	Invalidity
ON	Validity

##### 1-5 Memory backup setting

Set to ON to use batteries for the memory backup. If batteries are not used, all of the settings stored in memory will be deleted if there is a power failure.

※ This function is wired remotecontrol only.

(◆ . . . Factory setting)

DIP-SW No.6	Memory backup
◆ OFF	Invalidity
ON	Validity

## 2-17. OPTIONAL PARTS

### ■ Simple remote controllers UTB - YPB : FUJITSU BRAND UTB - GPB : GENERAL BRAND

Remote controller which gives priority to ease-of-use and allows operation of the necessary functions only.



DUCT TYPE  
AR7 - AR18K

DUCT TYPE  
AR7 - AR18K

### ■ Remote sensor unit UTD - RS100

#### Accurate and Comfortable

- New amenity space can be offered by installing the thermo sensor in the remote controller.
- Because the remote controller has the switching function, the user can select the position of the sensor. (Room temperature sensor selection)

