

**SPLIT TYPE AIR
CONDITIONER (50Hz)**

DUCT type

SERVICE MANUAL

Models	Indoor unit	Outdoor unit
	ARY12RLB	AOY12RGA

CONTENTS

SPECIFICATIONS	1
OUTLINE AND DIMENSIONS.....	2
CIRCUIT DIAGRAM	3
INDOOR P. C. BOARD CIRCUIT DIAGRAM	4
OUTDOOR P. C. BOARD CIRCUIT DIAGRAM	5
PRINTED CIRCUIT BOARD LAYOUTS	6
REFRIGERANT SYSTEM DIAGRAM	9
DISASSEMBLY ILLUSTRATION	10
PARTS LIST	16

S P E C I F I C A T I O N S

INDOOR UNIT		ARY12RLB
OUTDOOR UNIT		AOY12RGA
COOLING CAPACITY	(kW)	3.4 - 3.5
HEATING CAPACITY	(kW)	4.0 - 4.1

ELECTRICAL DATA

POWER SOURCE	(V)	220 - 240
FREQUENCY	(Hz)	50
RUNNING CURRENT	(A)	
	COOLING	5.5 - 5.3
	HEATING	5.7 - 5.5
INPUT WATTS	(kW)	
	COOLING	1.20 - 1.25
	HEATING	1.25 - 1.30
EER	(kW/kW)	
	COOLING	2.83 - 2.80
	HEATING	3.20 - 3.15
MOISTURE REMOVAL	(ℓ/hr)	1.1
AIR CIRCULATION-HI	(m ³ /hr)	460

COMPRESSOR

TYPE	Hermetic type, Permanent split condenser, 2 pole, Single phase, Induction motor
CODE	GRG133CA

FAN MOTOR

POWER SOURCE	(V)	220 - 240
INDOOR UNIT	TYPE	MFA-12FTT
	HI-SPEED	(r.p.m.) 640
	MED-SPEED	(r.p.m.) 610
	LO-SPEED	(r.p.m.) 580
OUTDOOR UNIT	TYPE	MFB-09FT
	HI-SPEED	(r.p.m.) 740
	LO-SPEED	(r.p.m.) 440

DIMENSIONS

INDOOR UNIT	H x W x D	(mm)	217 x 953 x 595
OUTDOOR UNIT			530 x 750 x 250

WEIGHTS

INDOOR UNIT	GROSS / NET	(kg)	29 / 25
OUTDOOR UNIT			39 / 37

REFRIGERANT CHARGE

PIPE LENGTH	15 m or less
FULL CHARGE AMOUNT	1,020 g (36.0 oz.)

Note : • Since this is a chargeless air conditioner, if the piping length is 15 m(49 ft.) or less, additional charging is unnecessary.
 • The above list shows values at the external static pressure of 0 mmAq (0 Pa).

OUTLINE AND DIMENSIONS

INDOOR UNIT

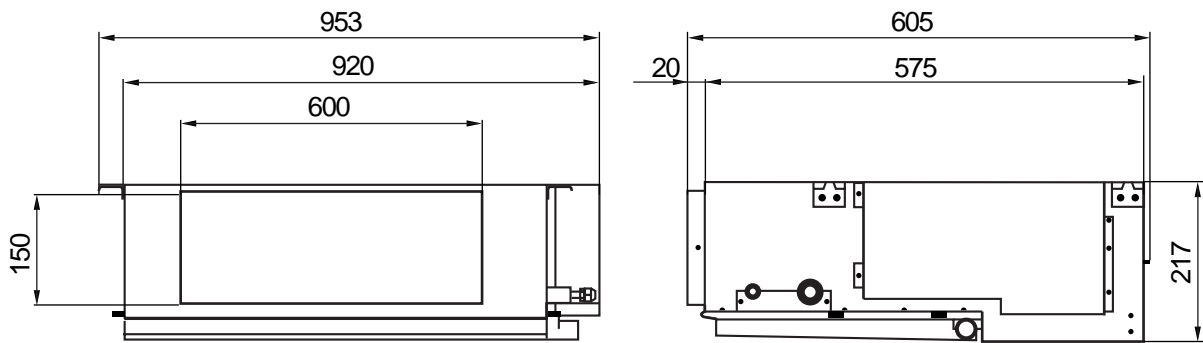
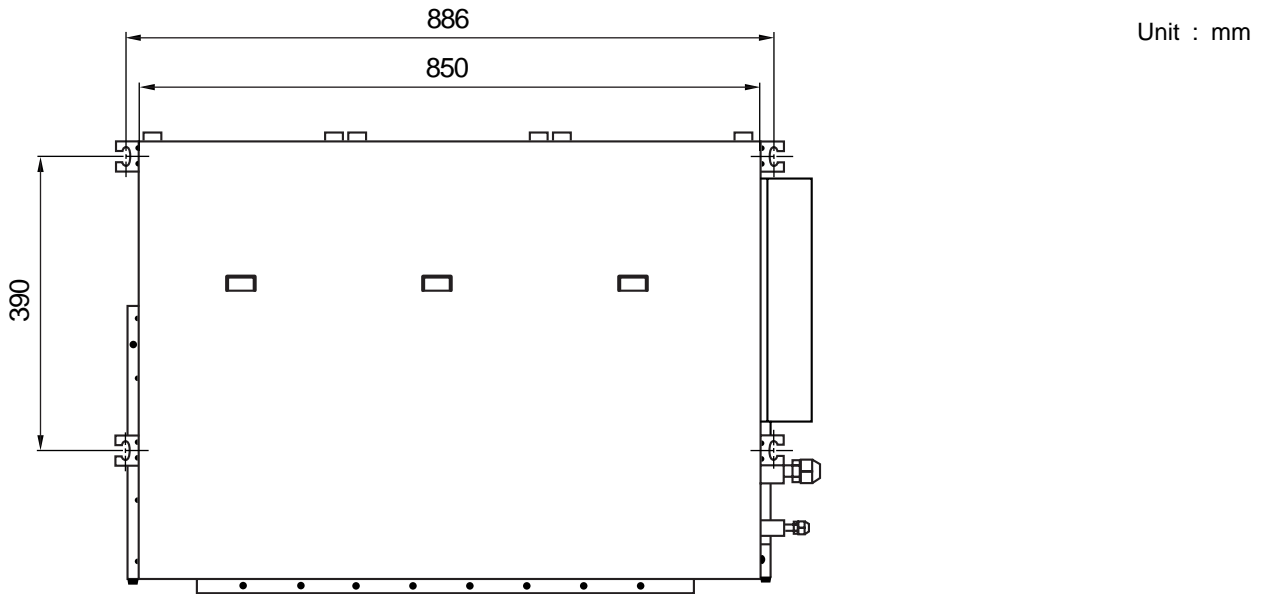

OUTDOOR UNIT

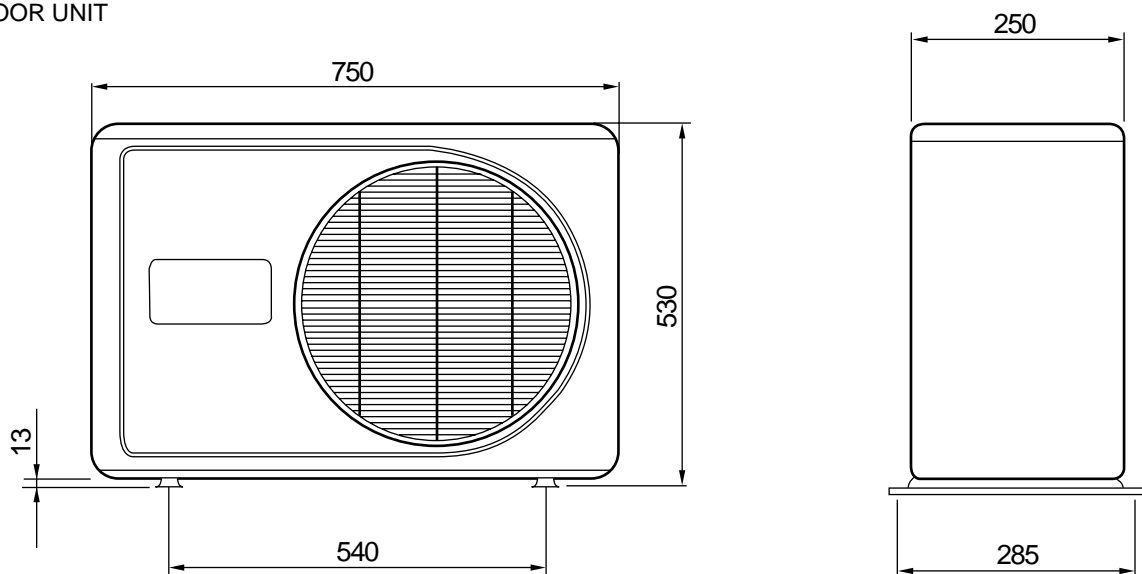

REFRIGERANT SYSTEM DIAGRAM

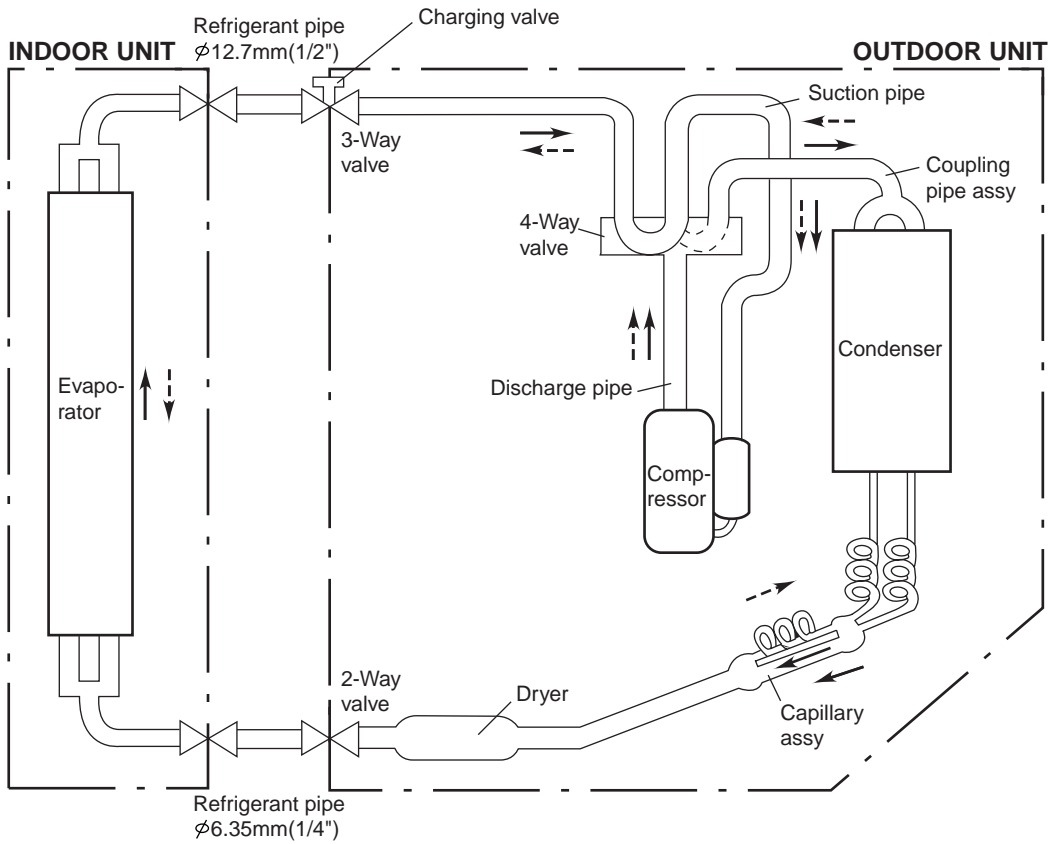

Cooling \longrightarrow
 Heating \dashrightarrow
 : Flare coupling

CIRCUIT DIAGRAM

Models : ARY12RLB / AOY12RGA

INDOOR UNIT

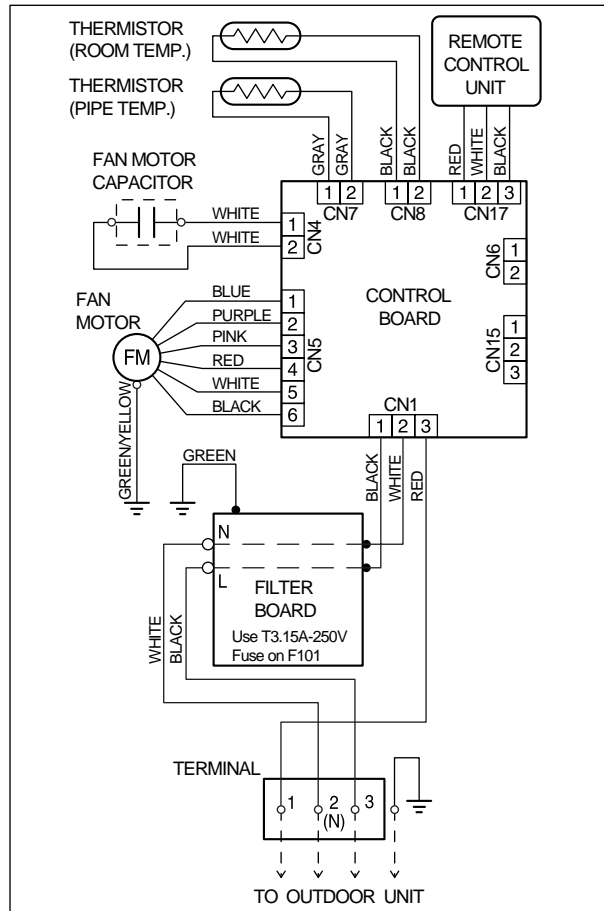

FAN MOTOR CAPACITOR	2.3 μF
----------------------------	------------------------------

OUTDOOR UNIT

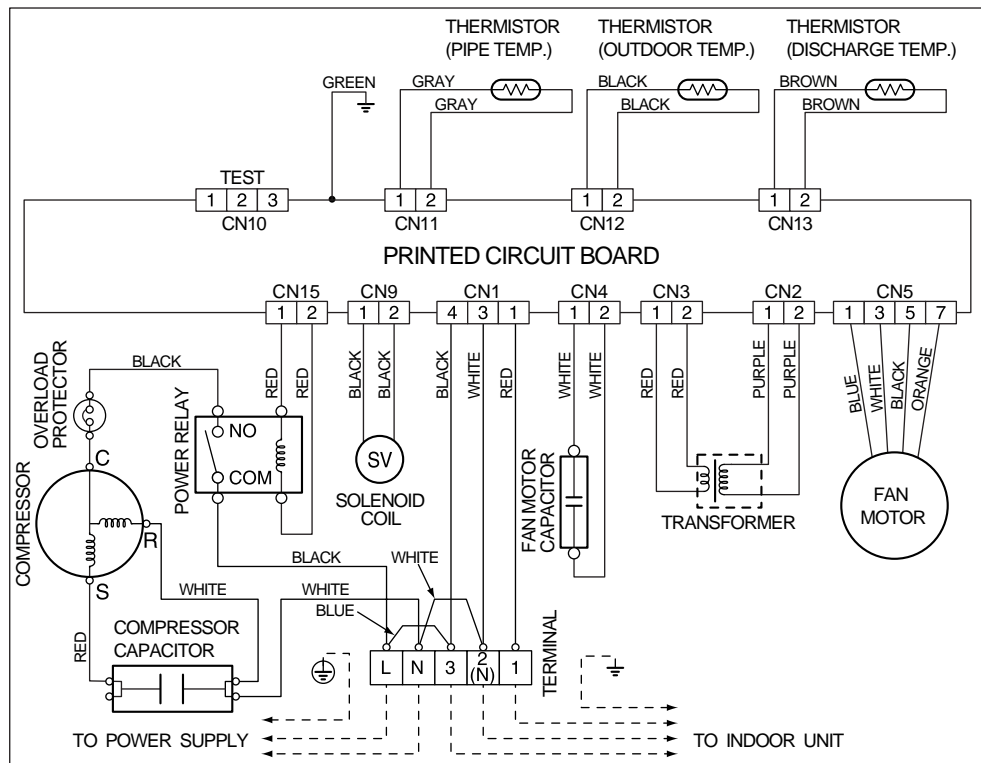

COMPRESSOR CAPACITOR	30 μF
FAN MOTOR CAPACITOR	1.6 μF

INDOOR PRINTED CIRCUIT BOARD CIRCUIT DIAGRAM

Model : ARY12RLB

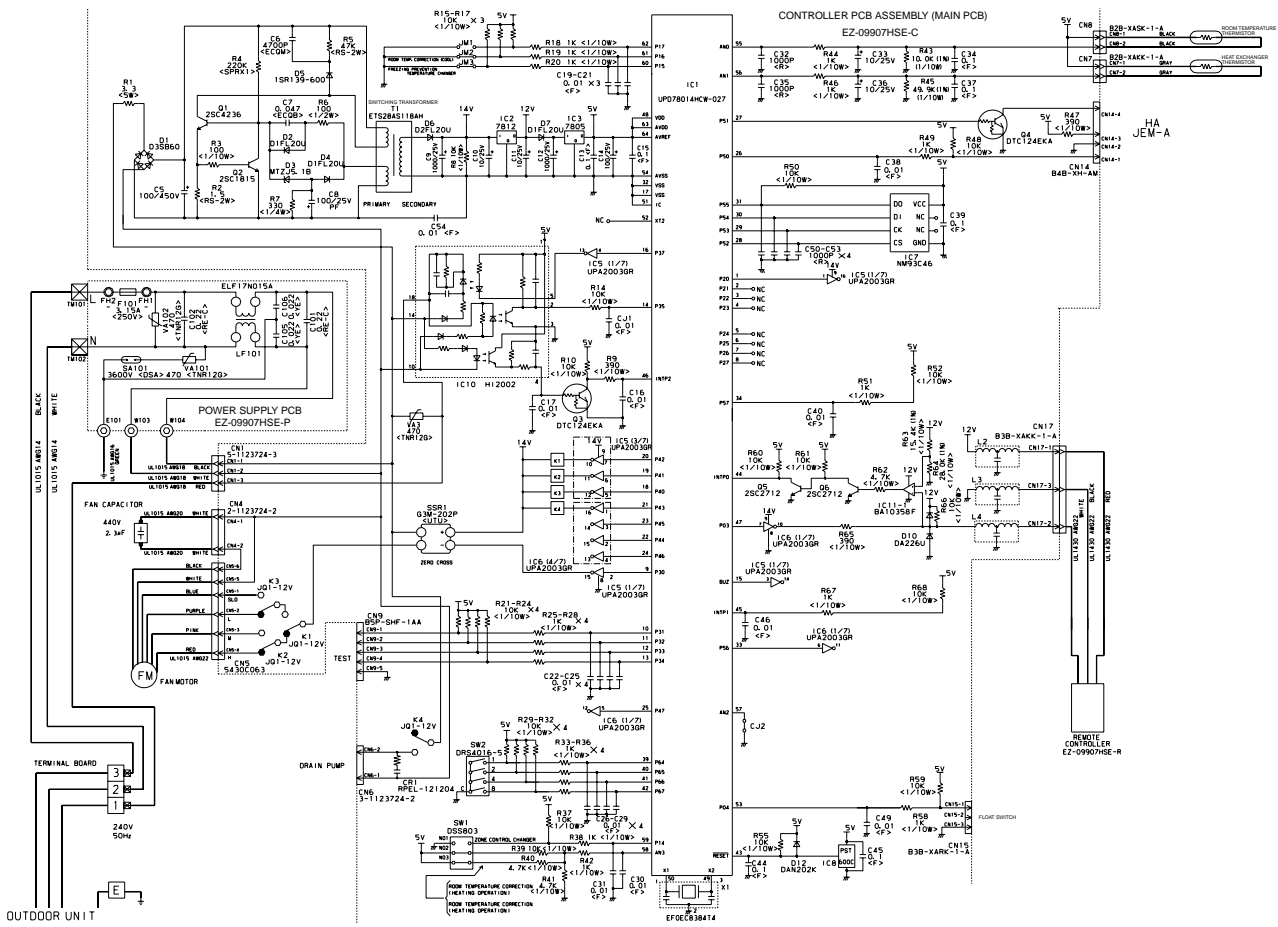

OUTDOOR PRINTED CIRCUIT BOARD CIRCUIT DIAGRAM

Model : AOY12RGA

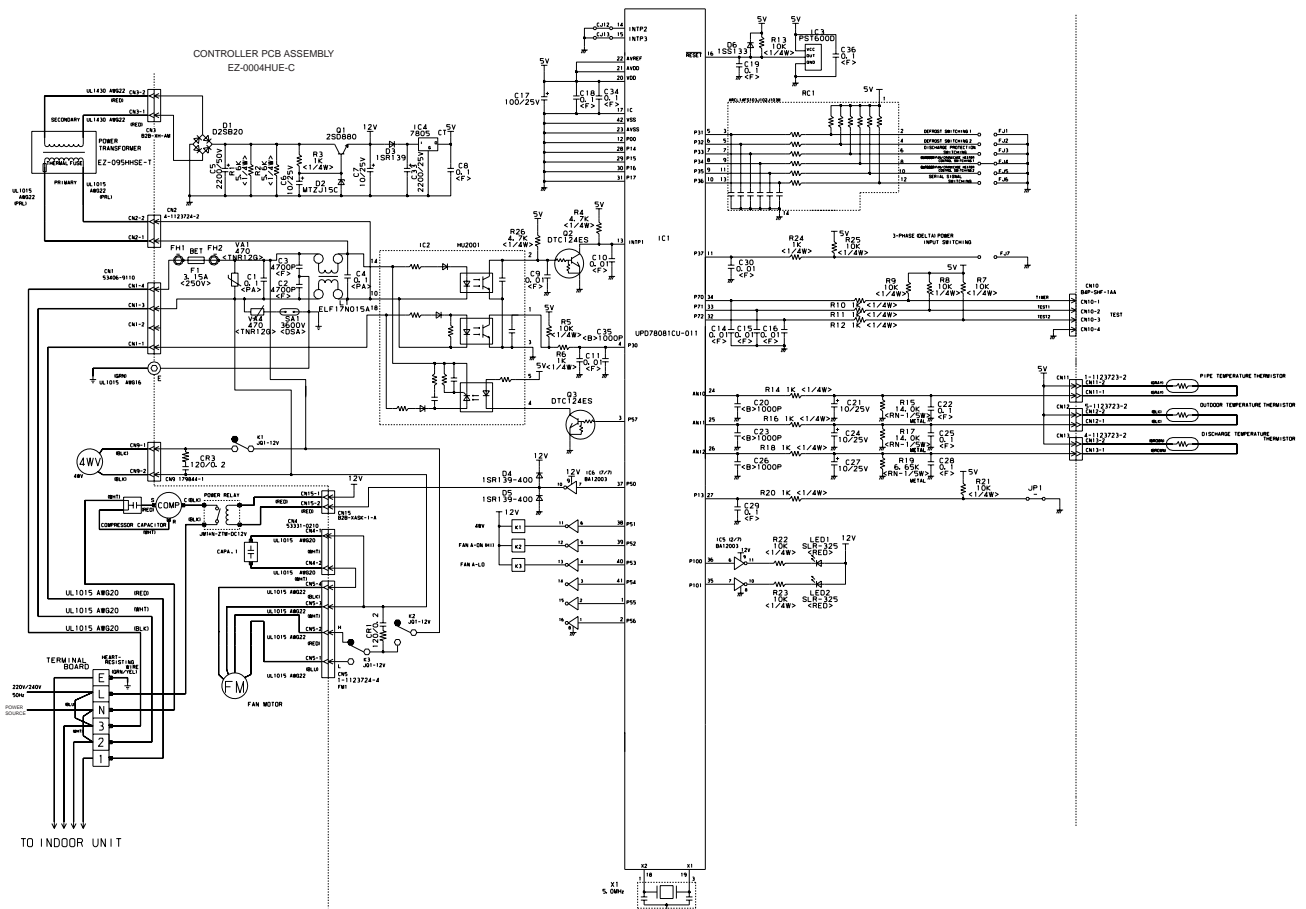

DISASSEMBLY ILLUSTRATION

Model : AOY12RGA

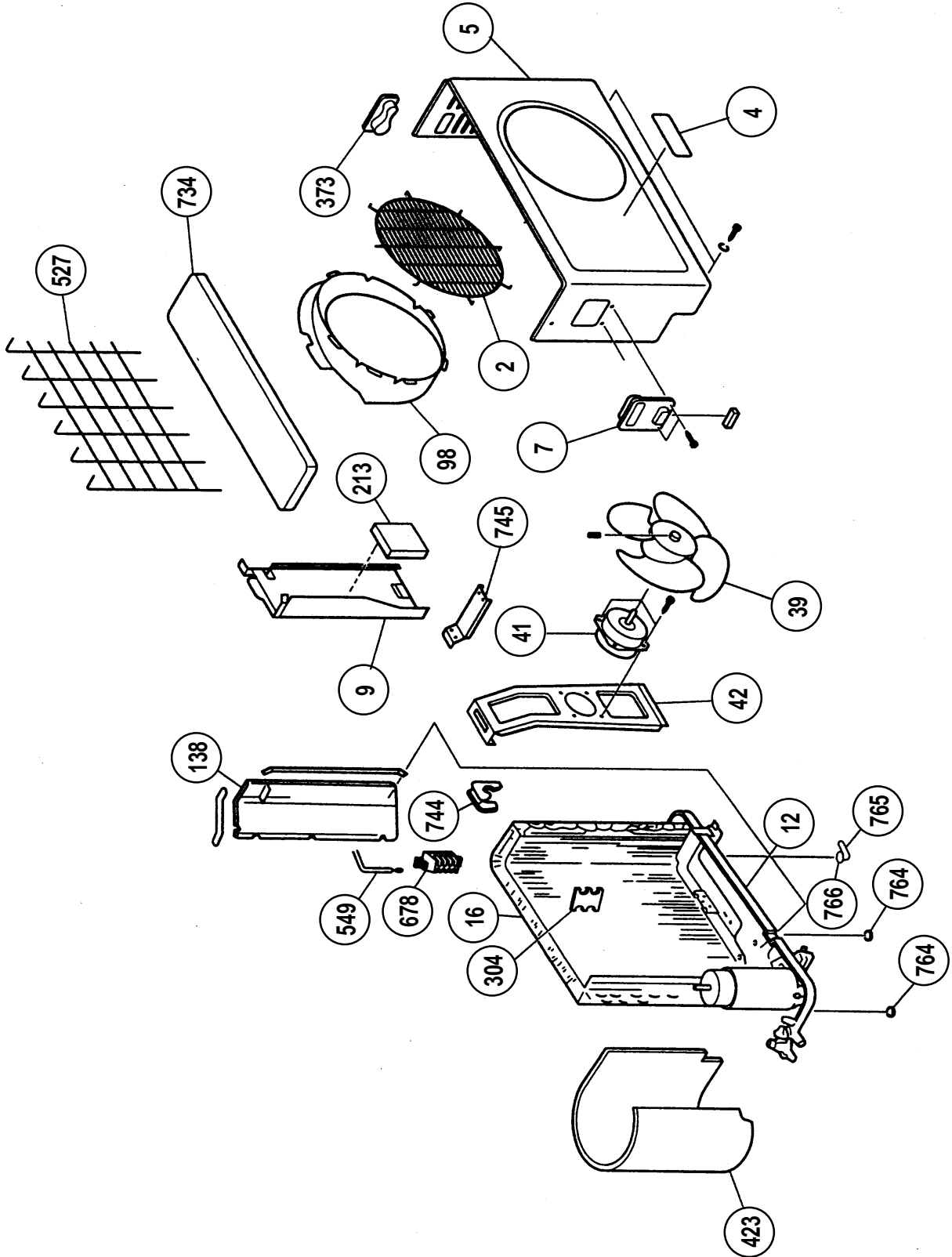

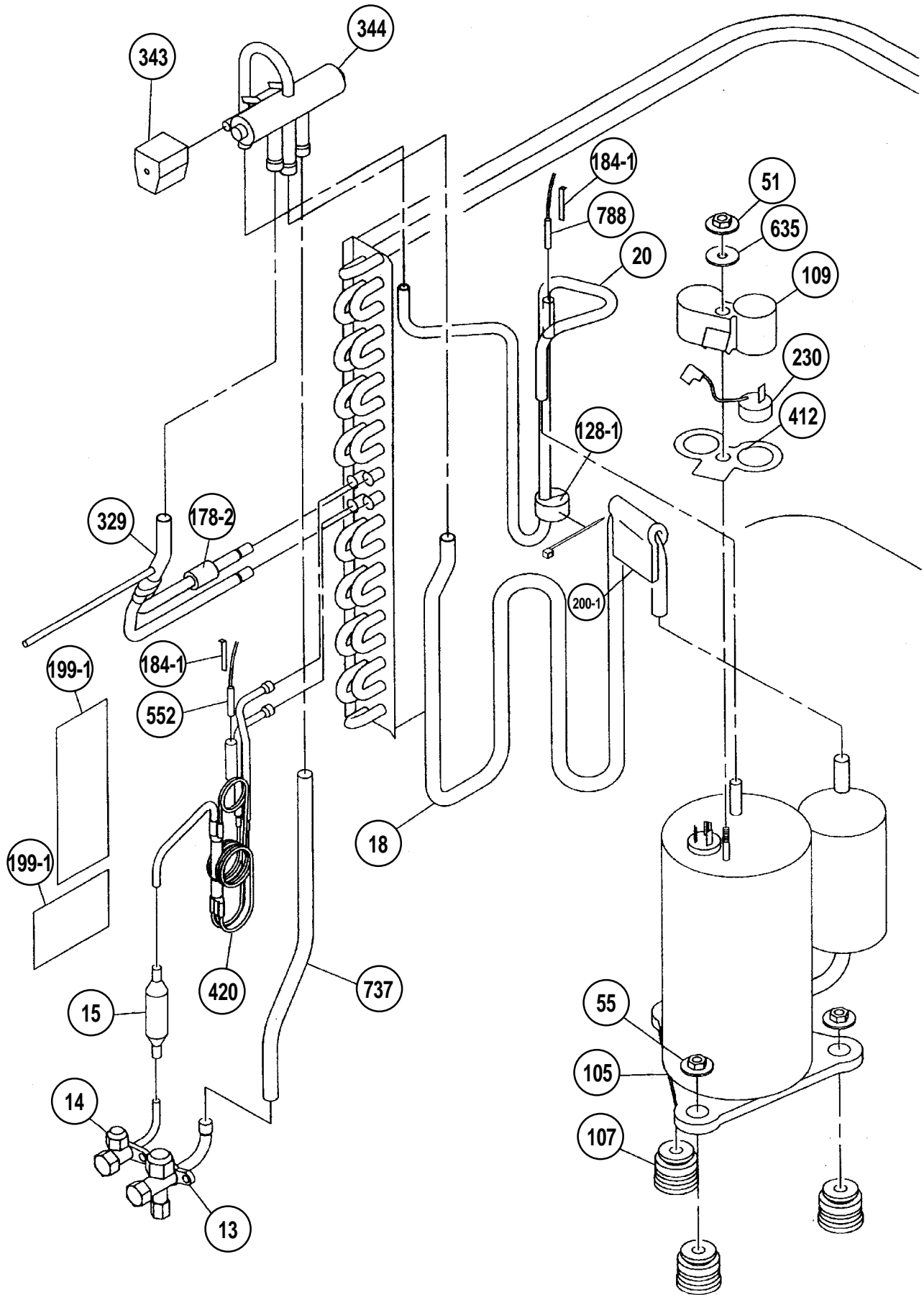

Model : AOY12RGA

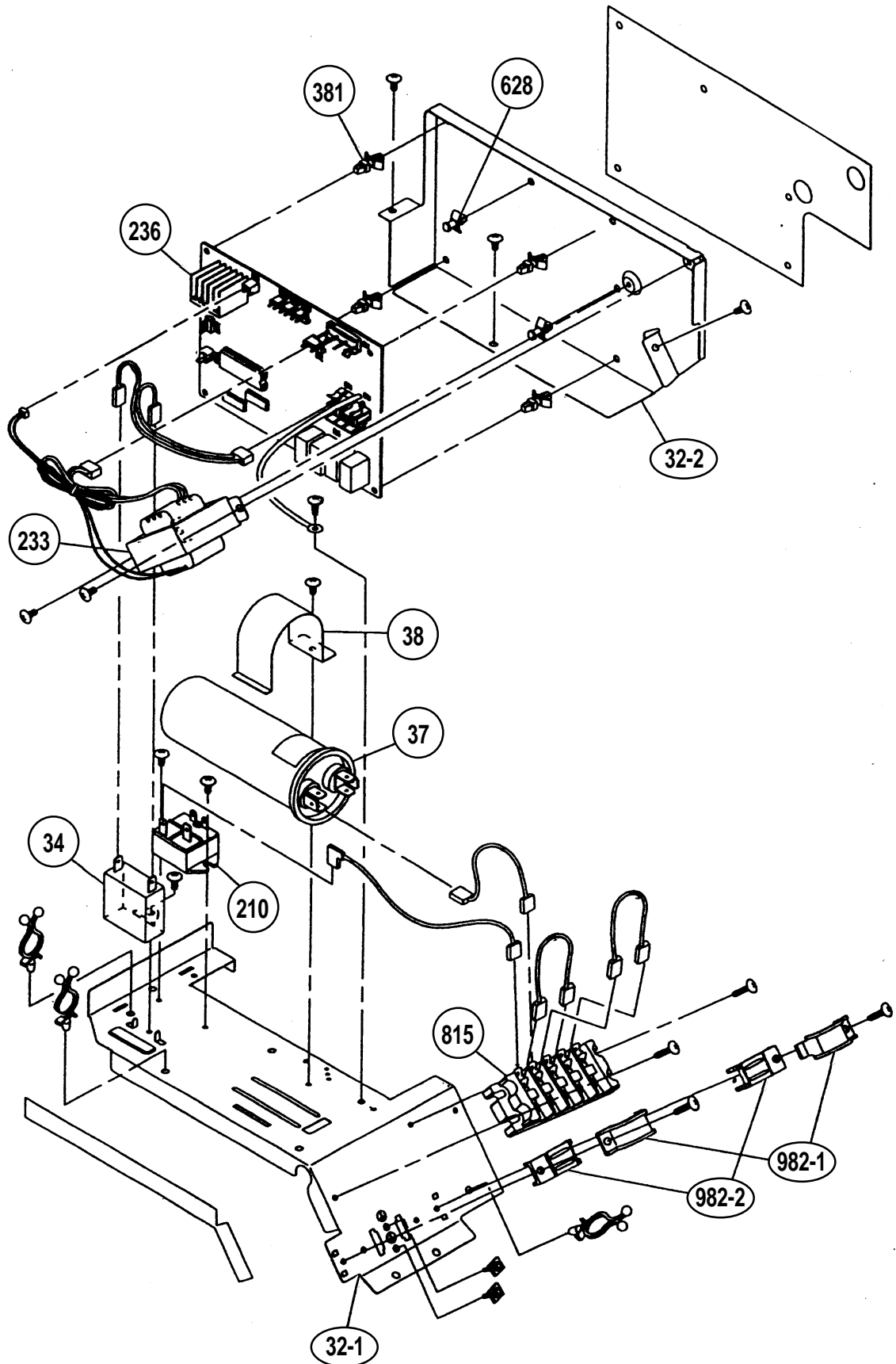

Model : ARY12RLB

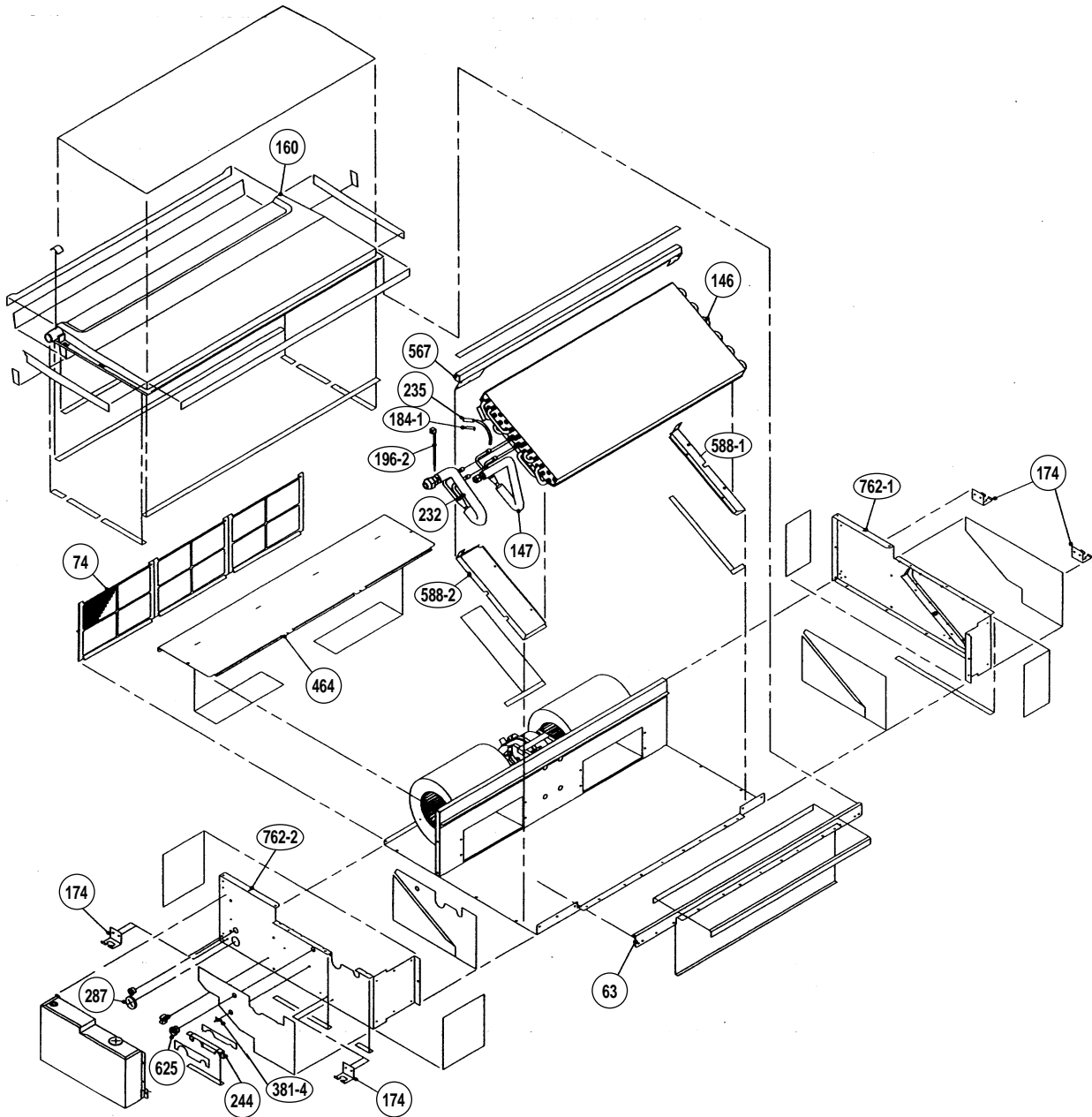

Model : ARY12RLB

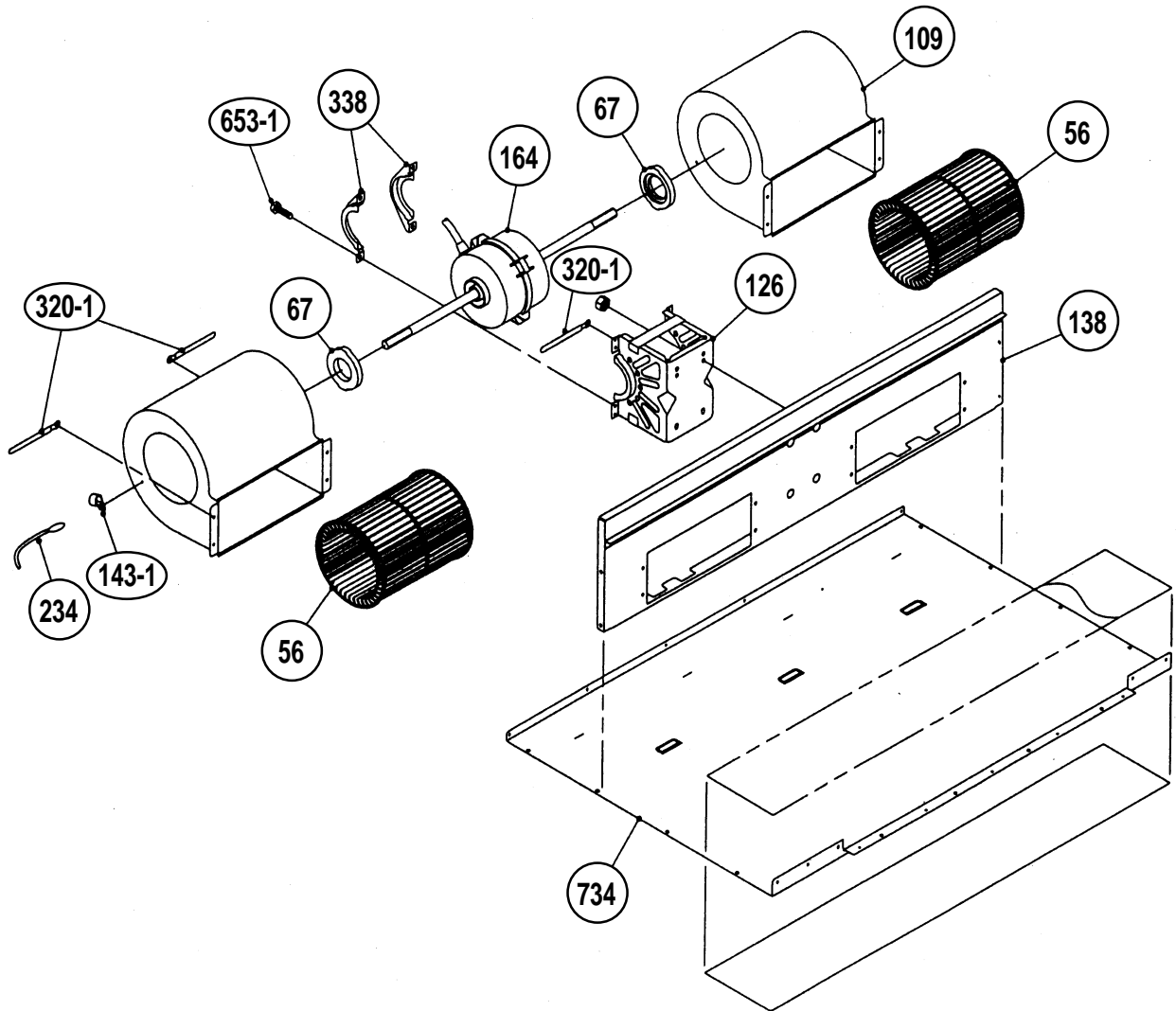

Model : ARY12RLB

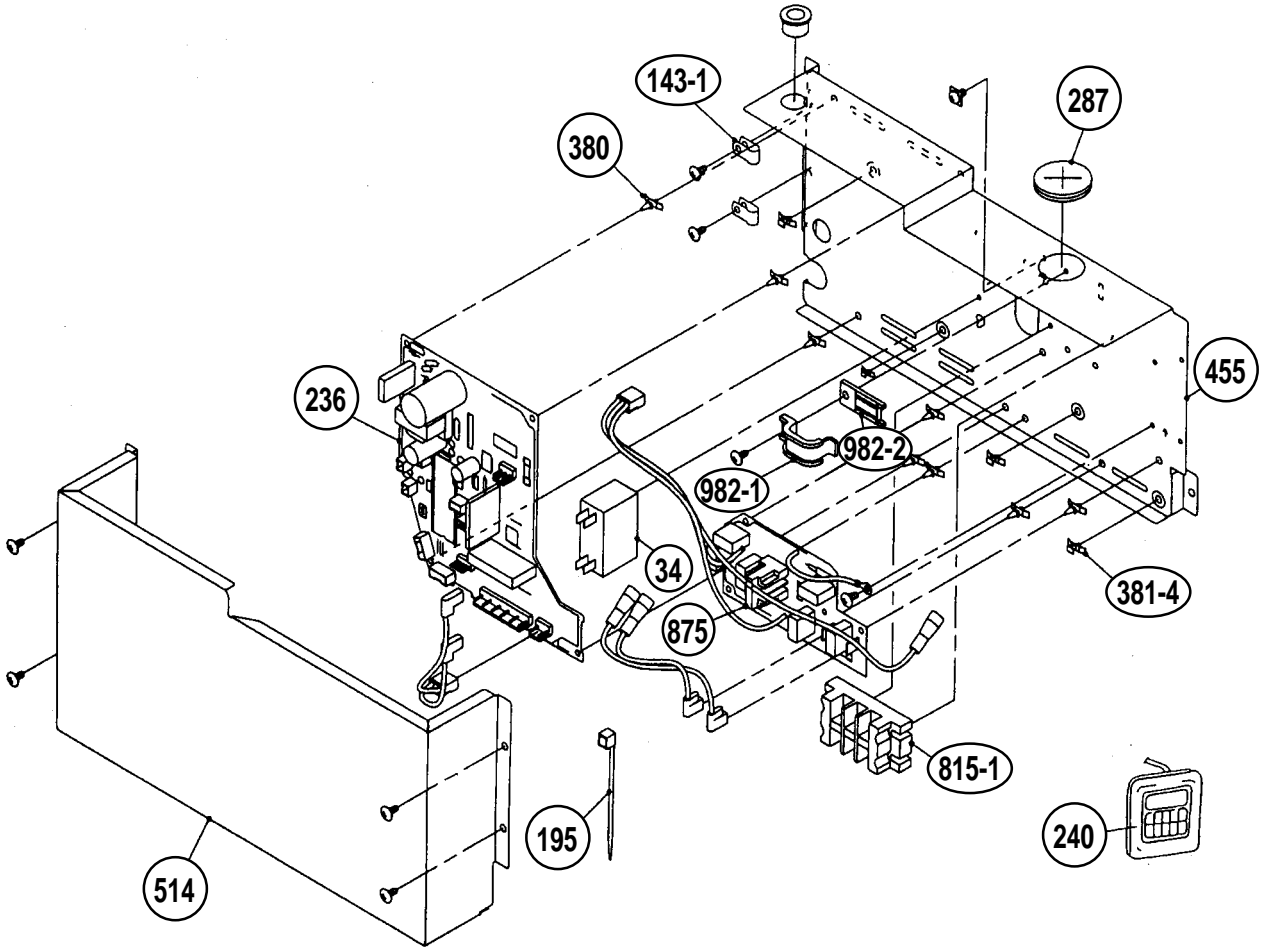

PARTS LIST

When you order parts, please make a photocopy of this page
and fill the number of the parts in the "Order" column.

INDOOR UNIT (ARY12RLB)

Ref. No.	Description	Part No.	Ord. Q'ty	Ref. No.	Description	Part No.	Ord. Q'ty
34	Capacitor (Fan Motor)	9357965017		244	Cover (Piping)	9363327007	
56	Sirocco Fan Assy	9358621004		287	Cap (Power)	9352173011	
63	Front Panel Assy	9363723007		320-1	Wire Clamp Metal	313483219905	
67	Rubber (Vibration - proof)	313659068604		338	Motor Fixture	9358594001	
74	Filter	9363326000		380	Locking Spacer	313209391403	
109	Casing Assy	9363322002		381-4	Locking Spacer	0600118075	
126	Motor Fixing Table Assy	9358591000		455	Control Box	9363200003	
138	Panel Assy (Motor)	9363401004		464	Cover (Cabinet)	9363400007	
143-1	Clamp NK-3N	313361274700		514	Control Box Cover	9363201000	
146	Evaporator Assy	9364456034		567	Support Plate (Eva.)	9363404005	
147	Inlet Pipe (Eva.) Assy	9363373004		588-1	Bracket Eva. R	9363199000	
160	Drain Pan	9363405002		588-2	Bracket Eva. L	9363198003	
164	Fan Motor Assy	9600778111		625	Cord Bushing	9359240006	
174	Hook Metal	9363195002		653-1	Bolt (Fan Motor Fixing)	0700156014	
184-1	Thermo. Spring-A	313728262708		734	Panel Top	9363504002	
195	Clamp SKB-100	313361275805		762-1	Side Panel-R Assy	9363507003	
196-2	Clamp SKB-150	313035356905		762-2	Side Panel-L Assy	9363505009	
232	Outlet Pipe (Eva.) Assy	9363377002		815-1	Terminal 3P	9356488005	
234	Thermistor Assy-Room	9703299018		875	Filter PCB Assy	9703583018	
235	Thermistor Assy-Pipe	9703297052		982-1	Cord Clamp	9356857009	
236	Controller PCB Assy	9703582028		982-2	Cord Clamp-B	9356858006	
240	Remote Control Unit	9701673049					

OUTDOOR UNIT (AOY12RGA)

Ref. No.	Description	Part No.	Ord. Q'ty	Ref. No.	Description	Part No.	Ord. Q'ty
2	Fan Cover	9304109006		200-1	BR Sheet-B	9351990022	
4	Emblem-Rear	9351355005		210	Main Relay	9356781007	
5	Cabinet-A, Painted	9302936017		213	Noise Insulation-B	313584258005	
7	Connector Cover	9357970004		230	Overload Relay	9363765007	
9	Cabinet-B, Painted	9303744017		233	Power Transformer	9701549016	
12	Base Assy, Painted	9354493032		236	Controller PCB Assy	9703572012	
13	3-Way Valve	9364616001		304	Thermostat Fixture-B	313349051500	
14	2-Way Valve	9364615004		329	Joint Pipe Assy	9357044002	
15	Dryer	313523082505		343	Solenoid Coil	9359616122	
16	Condenser Assy	9357055008		344	4-Way Valve	313943302804	
18	Suction Pipe	9365665008		373	Grip	313166178700	
20	Discharge Pipe Assy	9365666005		381	Locking Spacer	313209391506	
32-1	Control Box Metal-A	9363406009		412	Terminal Gasket	9362004008	
32-2	Control Box Metal-B	9363407006		420	Capillary Assy	9365982004	
34	Capacitor (Fan Motor)	9700468080		423	Noise Insulation-F	9350944019	
37	Running Capacitor	9356386059		527	Protection Net	9355444002	
38	Capacitor Clamp	313468061808		549	Thermistor Assy-Out	9357328027	
39	Propeller Fan Assy	9351589011		552	Thermistor Assy	9701330034	
41	Fan Motor Assy-Out	9600649107		628	Locking Spacer-B	313005446558	
42	Bracket (Motor)	313166243804		635	Terminal Washer	9359428015	
51	Special Nut	9359430018		678	Bracket (Thermistor)	313557406106	
55	Special Nut M8 (For Comp.)	9355091008		734	Cabinet Top Plate	9302937014	
98	Fan Ring	313166296109		737	Suction Pipe-A	9357048000	
105	Compressor Assy	9365866009		744	Clamp (Condenser)	313166374106	
107	Rubber Seat-A (For Comp.)	9359425014		745	Motor Support	313166036308	
109	Terminal Cover (For Comp.)	9363263008		764	Drain Cap	313166024302	
128-1	Rubber (Discharge Pipe)	313155086308		765	Drain Pipe (L-type)	9301102000	
138	Separate Wall	9303729014		766	Drain Pipe Packing	9301143003	
178-2	Capillary Holder Rubber	313394274808		788	Thermistor-Discharge	9358337011	
184-1	Thermo. Spring-A	313728262708		815	Terminal-5P	9356497021	
199-1	BR Sheet	313612108209		982-1	Cord Clamp	9356857009	
				982-2	Cord Clamp-C	9359677000	

[INDOOR UNIT]
CONTROLLER PCB ASSEMBLY (Ref. No.236)

Ref. No.	Description	Part No.	Ord. Q'ty	Ref. No.	Description	Part No.	Ord. Q'ty
IC1	IC μ PD 78014HCW-027	9703514012		R64	Res. 1/10W 28k Ω \pm 1%	0201114445	
IC2	IC NJM 7812FA	0100462104		C5	Cap, Elec. 450V 100 μ F	0300256060	
IC3	IC NJM 7805FA	0100462081		C6	Cap, Plastic. 4700pF	0300269091	
IC5,6	IC μ PA 2003GR	0100028041		C7	Cap, Plastic. 50V 0.047 μ F	0300169339	
IC7	IC BR 93LC46RF-E2	0100295016		C8	Cap, Elec. 25V 100 μ F	0301197560	
IC8	IC PST 600CMTR	0101461120		C9	Cap, Elec. 25V 1000 μ F	0301196495	
IC10	IC HI2002	9701384020		C10,11,33,36	Cap, Elec. 25V 10 μ F	0301192312	
IC11	IC BA10358F	0101846071		C12	Cap, Elec. 25V 1000 μ F	0301158264	
Q1	Xstr 2SC4236	0000164047		C13,15,34,37,39,44,45	Cap, Ceramic 50V 0.1 μ F	0300311752	
Q2	Xstr 2SC1815	0000002011		C14	Cap, Elec. 25V 100 μ F	0301192350	
Q3,4	Xstr DTC124EKA	0000936033		C16,17,19-31,38,40,46,49,CJ1	Cap, Ceramic 50V 0.01 μ F	0300311738	
Q5,6	Xstr 2SC2712	0000781053		C32,35,50-53	Cap, Ceramic 50V 1000pF	0300308509	
D1	Diode D3SB60	0000689045		C54	Cap, Ceramic 0.01 μ F	0300209127	
D2,4,7	Diode D1FL20U	0000746519		VA3	Varistor TNR12G471K	0000038010	
D3	Diode MTZJ5.1B	0000852166		SSR1	Relay G3M-202P-UTU	9701829019	
D5	Diode 1SR139-600	0000353120		K1,2,3,4	Relay JQ1-12V	9701316014	
D6	Diode D2FL20U	0000906500		CR1	Network RPEL-121204-C	9701125012	
D10	Diode DA226U	0000625036		SW1	Switch, Side DSS803	9701392018	
D12	Diode DAN202K	0000684019		SW2	Switch, Rotary DRS4016-5	9701694013	
R1	Res. 5W 3.3 Ω \pm 10%	0200153148		T1	Power Transformer ETS28AS118AH	9702727017	
R2	Res. Metal 2W 1.5 Ω \pm 5%	0201107119		X1	Ceramic Resonator EF0EC8384T4	9701261017	
R3	Res. 1/10W 100 Ω \pm 5%	0200212500		L2-4	EMI Filer EXCEMT103DT	0400406396	
R4	Res. Carbon 220k Ω \pm 5%	0200111353		CJ2	Res. 0 Ω	0200212012	
R5	Res. 2W 47k Ω \pm 5%	0201107652		JM2-4,6	Wire 0.6dia. L=10mm	9700025016	
R6	Res. 1/2W 100 Ω \pm 5%	0200731506		JM9	Res. 0 Ω	0200230016	
R7	Res. 1/4W 330 Ω \pm 5%	0200708621		CN1	Plug, PCB 5-1123724-3	0501321635	
R8,10,14-17,21-24,29-32,37,39,48,50,52,55,59,60,61,66,68	Res. 1/10W 10k Ω \pm 5%	0200213019		CN4	Plug, PCB 2-1123724-2	0501321529	
R9,47,65	Res. 1/10W 390 Ω \pm 5%	0200212647		CN5	Plug, PCB 5430C063	0500957026	
R18-20,25-28,33-36,38,42,44,46,49,51,58,67	Res. 1/10W 1k Ω \pm 5%	0200212746		CN6	Plug, PCB 3-1123724-2	0501321536	
R40,41,62	Res. 1/10W 4.7k Ω \pm 5%	0200212906		CN7	Plug, PCB B2B-XAKK-1-A	0501045227	
R43	Res. 1/10W 10k Ω \pm 1%	0200279497		CN8	Plug, PCB B2B-XASK-1-A	0501045012	
R45	Res. 1/10W 49.9k Ω \pm 1%	0200279824		CN9	Plug, PCB B5P-SHF-1AA	0500006069	
R63	Res. 1/10W 15.4k Ω \pm 1%	0200279565		CN14	Plug, PCB B4B-XH-AM	0500005314	
				CN15	Plug, PCB B3B-XARK-1-A	0501045319	
				CN17	Plug, PCB B3B-XAKK-1-A	0501045357	

FILTER PCB ASSEMBLY (Ref. No.875)













Ref. No.	Description	Part No.	Ord. Q'ty	Ref. No.	Description	Part No.	Ord. Q'ty
C101,102	Cap. Plastic 0.22 μ F	0300304099		LF101	EMI Filter ELF17N015A	0400197119	
C105,106	Cap. Plastic 0.022 μ F	0301052098		F101	Fuse 2183.15	0600285210	
SA101	Arrester DSA-362MA-05	0600168032		FH1,2	Fuse Holder PFC5000-0502	0500158072	
VA101,102	Varistor TNR12G471K	0000038010		E101	Wire w/Terminal L=100 GRN	9702313012	
TM101,102	Plug Contact 86028	0500536016		W103,104	Wire #18 3P AWG18 3P	9702310059	

[OUTDOOR UNIT]
CONTROLLER PCB ASSEMBLY (Ref. No.236)



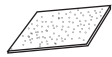

Ref. No.	Description	Part No.	Ord. Q'ty	Ref. No.	Description	Part No.	Ord. Q'ty
IC1	IC μ PD 78081CU-011	9701721016		C9-11,14-16,30	Cap, Ceramic 50V 0.01 μ F	0300013113	
IC2	IC HU2001	9701651016		C17	Cap, Elec. 25V 100 μ F	0300051375	
IC3	IC PST 600D-2-TP	0101461113		C20,23,26,35	Cap, Ceramic 50V 1000pF	0300011096	
IC4	IC NJM 7805FA	0100462081		C33	Cap, Elec. 25V 2200 μ F	0300915417	
IC5,6	IC BA12003	0101650012		F1	Fuse 2183.15	0600285210	
Q1	Xstr 2SD880	0000001014		FH1,2	Fuse Holder PFC5000-0502	0500158072	
Q2,3	Xstr DTC124ES	0000517010		SA1	Arrester DSA-362MA-05	0600168032	
D1	Diode D2SB20	0000599023		K1-3	Relay JQ1-12V	9701316014	
D2	Diode MTZJ15C	0000852203		CR1,3	Network RPEL-121204-C	9701125012	
D3-D5	Diode 1SR139-400	0000353137		L1	EMI Filter SU16VF-15030	0400134114	
D6	Diode 1SS133	0000572019		VA1,4	Varistor TNR12G471K	0000038010	
LED1,2	Diode SLR-325VC	0000813259		HT1	Heat Sink PUG 26-25	9701428014	
RC1	RC Module ARCL14FS103J102J103M	0200301020		X1	Ceramic Resonator EF0EC5004T4Z	9701261024	
R1,2	Res. Carbon 1/4W 5.6k Ω \pm 5%	0200994192		CN1	Plug, PCB 53406-9110	0500951086	
R3,6,10-12,14,16,18,20,24	Res. Carbon 1/4W 1k Ω \pm 5%	0200994017		CN2	Plug, PCB B2P3-VH-B-R	0500011766	
R4,26	Res. Carbon 1/4W 4.7k Ω \pm 5%	0200994178		CN3	Plug, PCB B2B-XH-AM	0500005321	
R5,7-9,13,21-23,25	Res. Carbon 1/4W 10k Ω \pm 5%	0200994253		CN4	Plug, PCB 53331-0210	0501033019	
R15,17	Res. Metal 1/5W 14k Ω	0201028612		CN5	Plug, PCB B4P7-VH-B	0500011742	
R19	Res. Metal 1/5W 6.65k Ω	0201028766		CN9	Plug, PCB 179844-1	0501121013	
C1,4	Cap, Plastic. 0.1 μ F	0300894835		CN10	Plug, PCB B4P-SHF-1AA	0500006038	
C2,3	Cap, Ceramic 4700pF	0300727546		CN11	Plug, PCB B2P-VH-B	0500011124	
C5	Cap, Elec. 50V 2200 μ F	0301206026		CN12	Plug, PCB B2P-VH-B-C	0500011568	
C6,7,21,24,27	Cap, Elec. 25V 10 μ F	0300004258		CN13	Plug, PCB B2P-VH-B-R	0500011148	
C8,18,19,22,25,28,29,34,36	Cap, Ceramic 0.1 μ F	0300988251		CN15	Plug, PCB B2B-XASK-1-A	0501045012	
				E	Wire w/Terminal L=210 GRN	9701325016	

STANDARD ACCESSORIES

INDOOR UNIT ACCESSORIES

Name and Shape	Q'ty	Application	Part No.
Installation template 	1	For positioning the indoor unit	9364225005
Hook Metal 	4	For suspending the indoor unit from ceiling	9363195002
Tapping screw (φ 4 x 10) 	8	For installing the hanger	301171164104
Special nut A (large flange) 	4	For suspending the indoor unit from ceiling	313005446653
Special nut B (small flange) 	4		313005446759
Coupler heat insulation (large) 	1	For indoor side pipe joint (large pipe)	9350716029
Coupler heat insulation (small) 	1	For indoor side pipe joint (small pipe)	9352766015
Binder 	(Small) 1	For remote controller and remote controller cord binding	313361275805
	(Large) 4	For fixing the coupler heat insulation	312300787605
Remote control unit 	1		9701673063
Remote control unit cord clamp 	10	For installing the remote control unit cord	313714181904
Tapping screw (flush heads) 	10	For installing the remote control unit cord clamp	301141153027
Filter 	3		9363326000
Drain hose insulation 	1	Insulates the drain hose and vinyl hose connection	313806217708

OUTDOOR UNIT ACCESSORIES

Name and Shape	Q'ty	Application	Part No.
Hexagon wrench 	1	For vacuum	301980005800
Drain pipe packing 	1	For outdoor unit drain piping work (May not be supplied, depending on the model)	9301143003
Drain pipe 	1		9301102000
Cap (drain) 	2		313166024302