

SPLIT TYPE  
ROOM AIR CONDITIONER  
FLOOR CONSOLE /  
UNDER CEILING  
DUAL TYPE

# SERVICE MANUAL



Indoor unit	Outdoor unit
ABYF18LAT	AOYA18LACL
ABYF18LAT	AOYA18LALL
ABYF24LAT	AOYA24LACL
ABYF24LAT	AOYA24LALL

## CONTENTS

SPECIFICATIONS	1
OUTLINE AND DIMENSIONS	2
REFRIGERANT SYSTEM DIAGRAM	5
CIRCUIT DIAGRAM	6
PCB CIRCUIT DIAGRAM	7
ERROR DISPLAY	13
PARTS (indoor unit)	16
PARTS (outdoor unit)	26
ACCESSORIES	29

# SPECIFICATIONS

## ELECTRICAL DATA

TYPE		Cool & heat inverter	
INDOOR UNIT		ABYF18LAT	ABYF24LAT
OUTDOOR UNIT		AOYA18LA_L	AOYA24LA_L
COOLING CAPACITY		5.20 kW	7.10 kW
HEATING CAPACITY		6.00 kW	8.00 kW
POWER SOURCE		230 V	230 V
FREQUENCY		50 Hz	50 Hz
RUNNING CURRENT	COOLING	7.1 A	9.7 A
	HEATING	7.3 A	9.7 A
INPUT WATTS	COOLING	1.62 kW	2.21 kW
	HEATING	1.66 kW	2.21 kW
E.E.R.	COOLING	3.21 kW/kW	3.21 kW/kW
COP	HEATING	3.61 kW/kW	3.61 kW/kW
MOISTURE REMOVAL		2.0 L/hr	2.7 L/hr
AIR CIRCULATION HIGH		780 m <sup>3</sup> /hr	980 m <sup>3</sup> /hr

## FAN MOTOR

POWER SOURCE		230 V	230 V
INDOOR UNIT ( cool / heat )	High speed	1,040 / 1,040 r.p.m.	1,330 / 1,300 r.p.m.
	Middle	950 / 950 r.p.m.	1,150 / 1,150 r.p.m.
	Low	800 / 800 r.p.m.	1,000 / 1,000 r.p.m.
	Quiet	740 / 740 r.p.m.	780 / 780 r.p.m.
OUTDOOR UNIT		860 / 820 r.p.m.	1,050 / 1,050 r.p.m.

## NOISE LEVEL

INDOOR UNIT ( cool / heat )	43 dB / 43 dB	48 dB / 48 dB
OUTDOOR UNIT ( cool / heat )	50 dB / 50 dB	52 dB / 53 dB

## COMPRESSOR AND REFRIGERANT

TYPE		Hermetic type, 4 pole, 3 phase, DC inverter motor, Rotary	
DISCRIMINATION		DA130A1F-25NA	DA150A1F-20NA
WEIGHT (with oil)		9.6 kg	10.0 kg
PRECHARGED REFRIGERANT		1,250 g	1,700 g
REFRIGERANT TYPE		R410A	R410A
FULL CHARGE	Pipe length 15 m	1,250 g	1,700 g
	20 m	1,350 g	1,800 g
ADDITIONAL REFRIGERANT		20 g/m	20 g/m

## DIMENSIONS

INDOOR UNIT	H x W x D	199 x 990 x 655 mm	
OUTDOOR UNIT	H x W x D	578 x 790 x 300 mm	578 x 790 x 315 mm

## WEIGHT

INDOOR UNIT	Gross / Net	36 kg / 27 kg	
OUTDOOR UNIT	Gross / Net	44 kg / 40 kg	48 kg / 44 kg

# OUTLINE AND DIMENSIONS

## INDOOR UNIT

Unit : mm

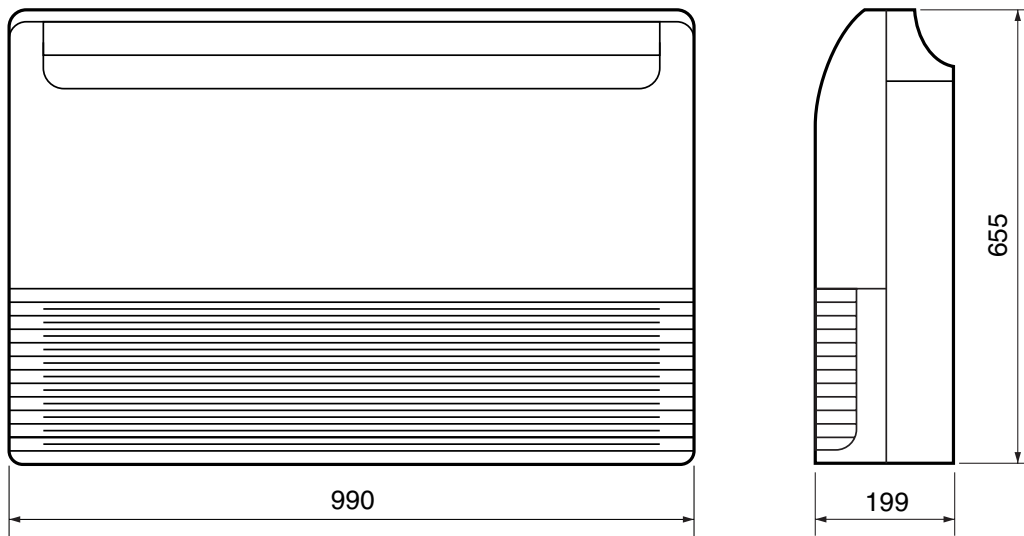

(rear view)

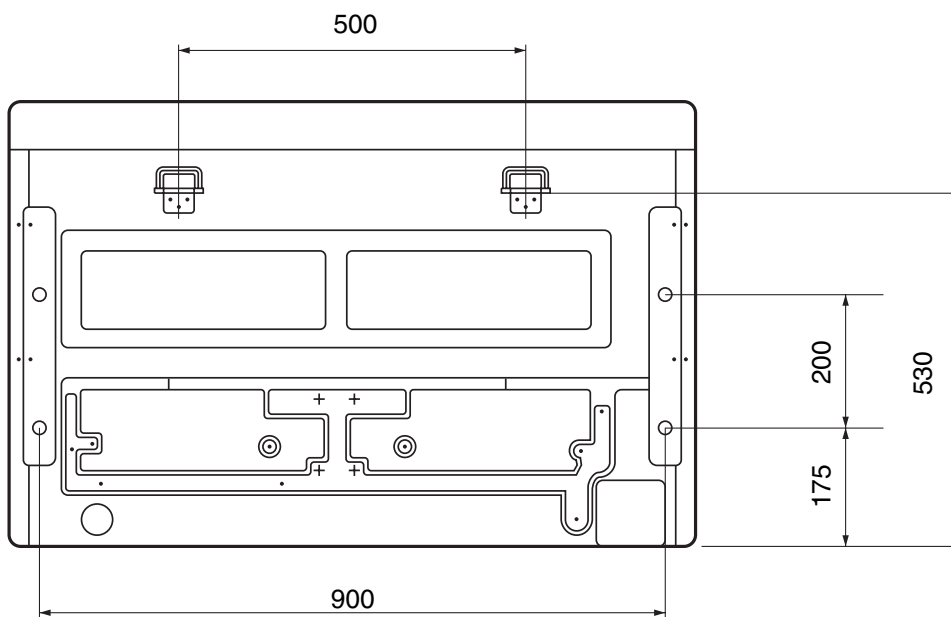

OUTDOOR UNIT  
AOYA18LA\_L

Unit : mm

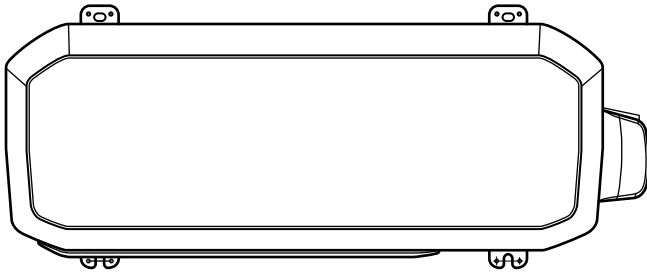

Top view

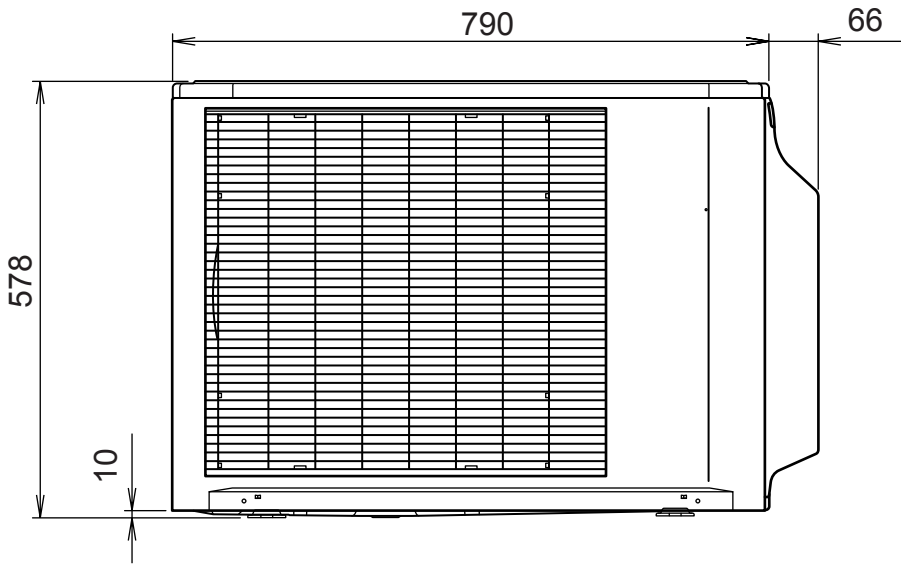

Front view

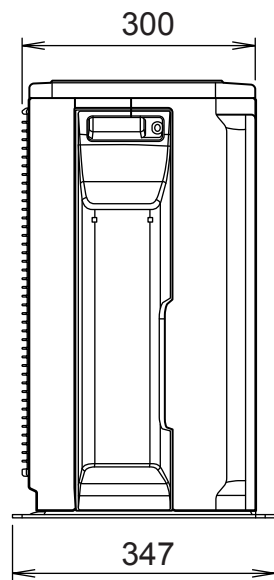

Side view

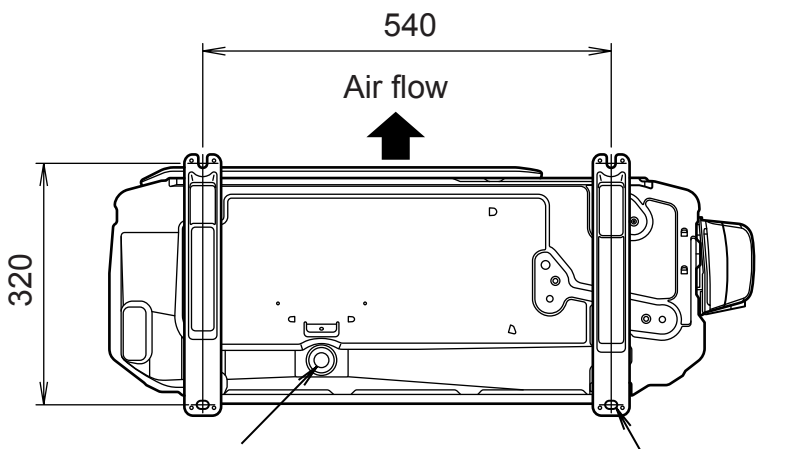

Drain pipe  
mounting place  
( $\phi$  20)

Bottom view

4- $\phi$ 10mm hole

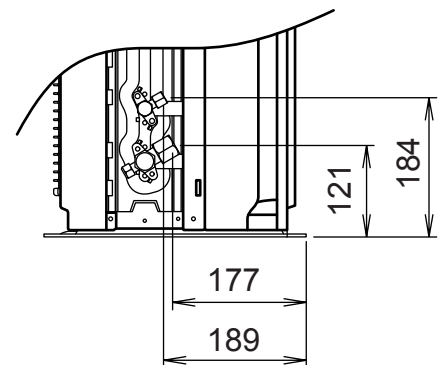

OUTDOOR UNIT  
AOYA24LA\_L

Unit : mm

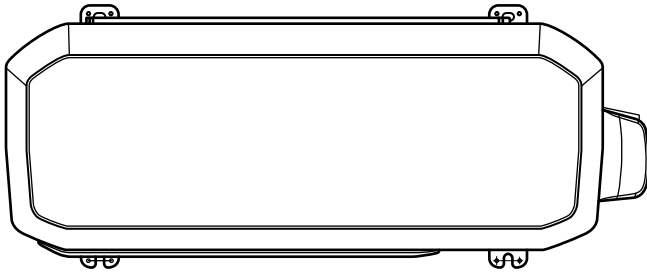

Top view

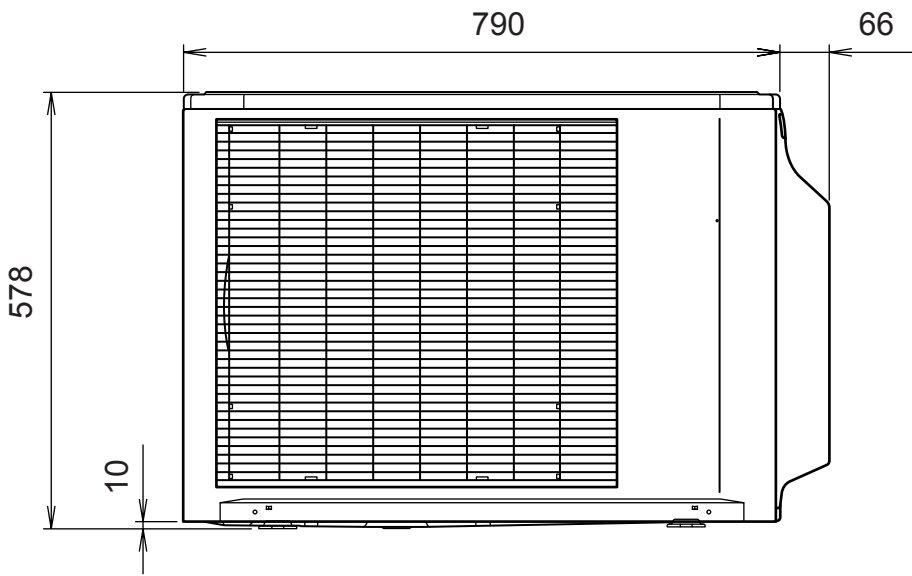

Front view

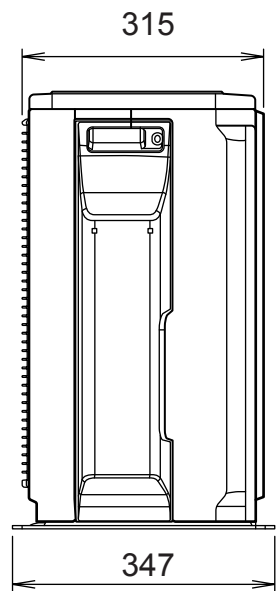

Side view

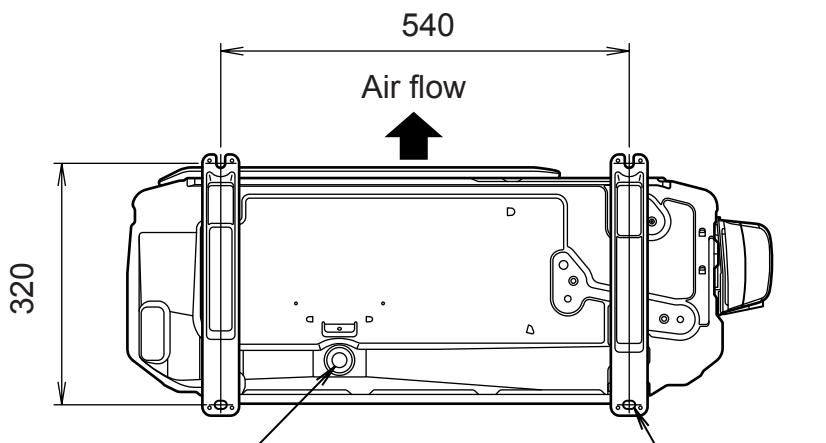

Drain pipe  
mounting place  
( $\phi$  20)

Bottom view

4- $\phi$  10mm hole

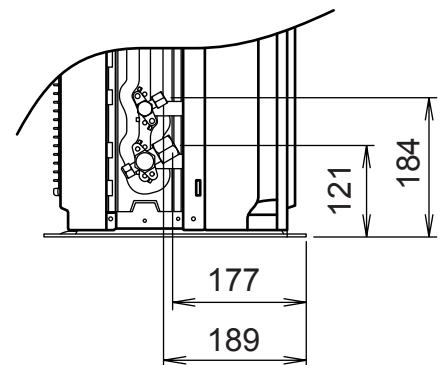

# REFRIGERANT SYSTEM DIAGRAM

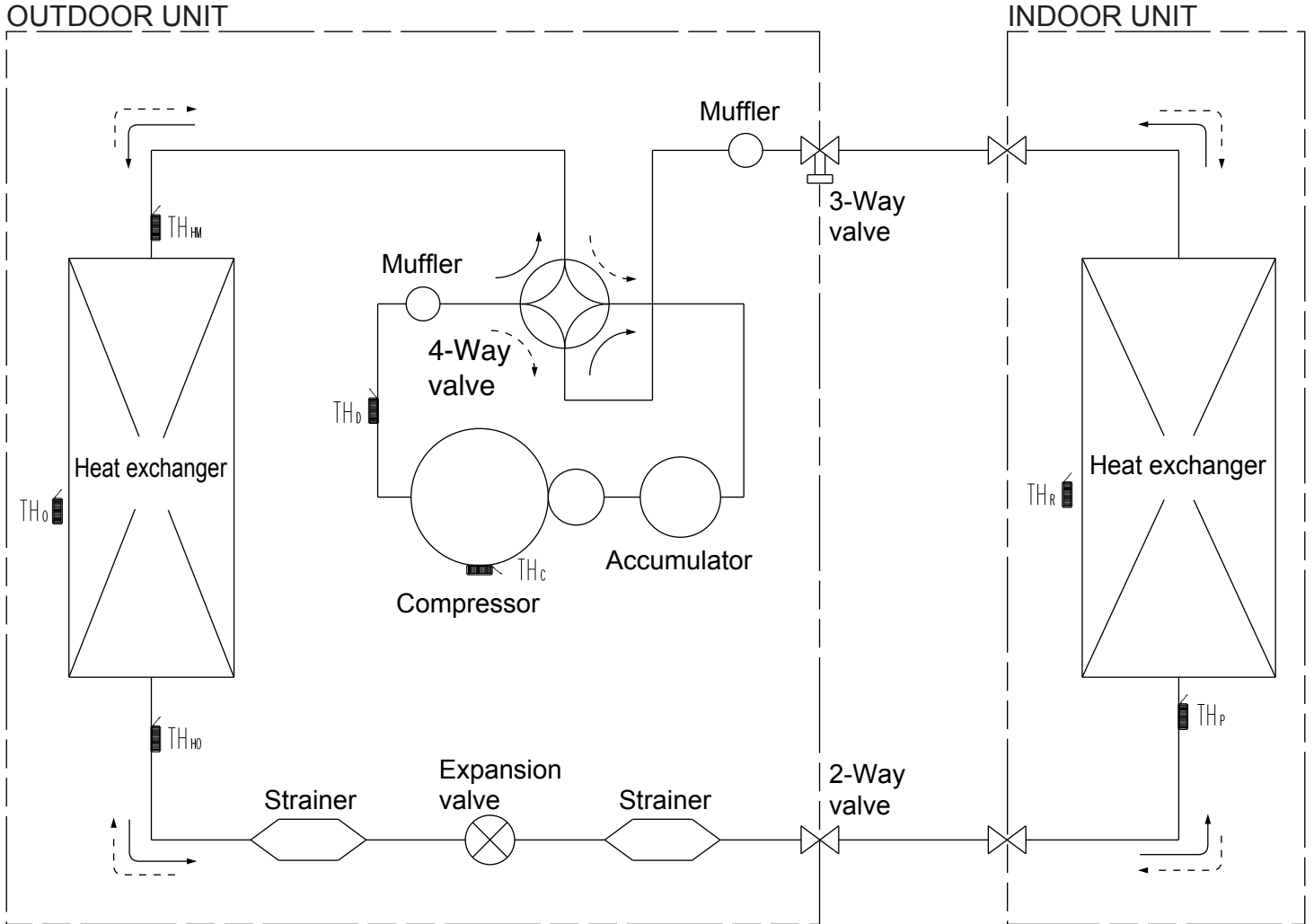

- TH<sub>c</sub> : THERMISTOR (COMPRESSOR)
- TH<sub>o</sub> : THERMISTOR (DISCHARGE)
- TH<sub>m</sub> : THERMISTOR (HEAT EXCHANGER MED)
- TH<sub>ho</sub> : THERMISTOR (HEAT EXCHANGER OUT)
- TH<sub>o</sub> : THERMISTOR (OUTDOOR)

- TH<sub>p</sub> : THERMISTOR (PIPE)
- TH<sub>r</sub> : THERMISTOR (ROOM)

Refrigerant pipe diameter  
 ABYF18LAT / AOYA18LA\_L  
 Liquid : 1/4" (6.35 mm)  
 Gas : 1/2" (12.70 mm)  
 ABYF24LAT / AOYA24LA\_L  
 Liquid : 1/4" (6.35 mm)  
 Gas : 5/8" (15.88 mm)

Refrigerant direction  
 ———→ Cool  
 - - - - -→ Heat

# CIRCUIT DIAGRAM

## INDOOR UNIT

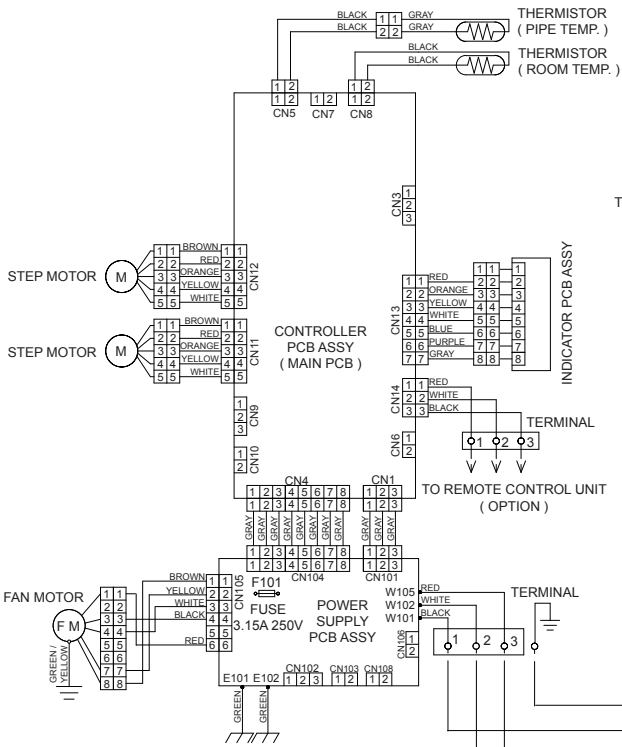

## OUTDOOR UNIT

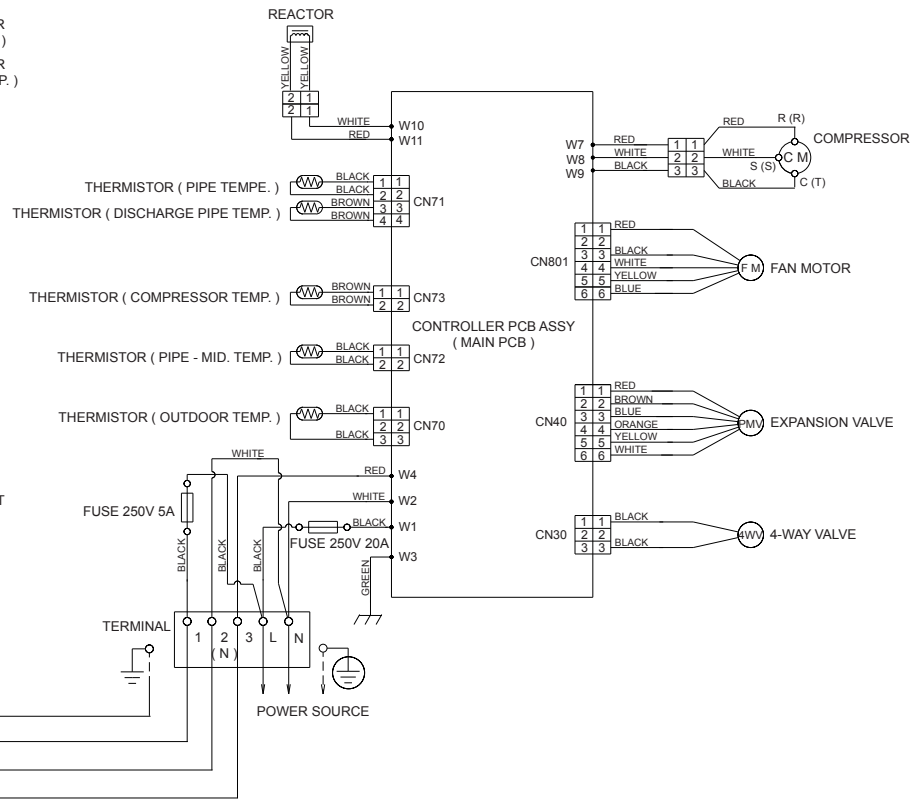

# INDOOR PCB CIRCUIT DIAGRAM

CONTROL UNIT  
 ABYF18LAT : EZ-0070MHSE  
 ABYF24LAT : EZ-0070PHSE

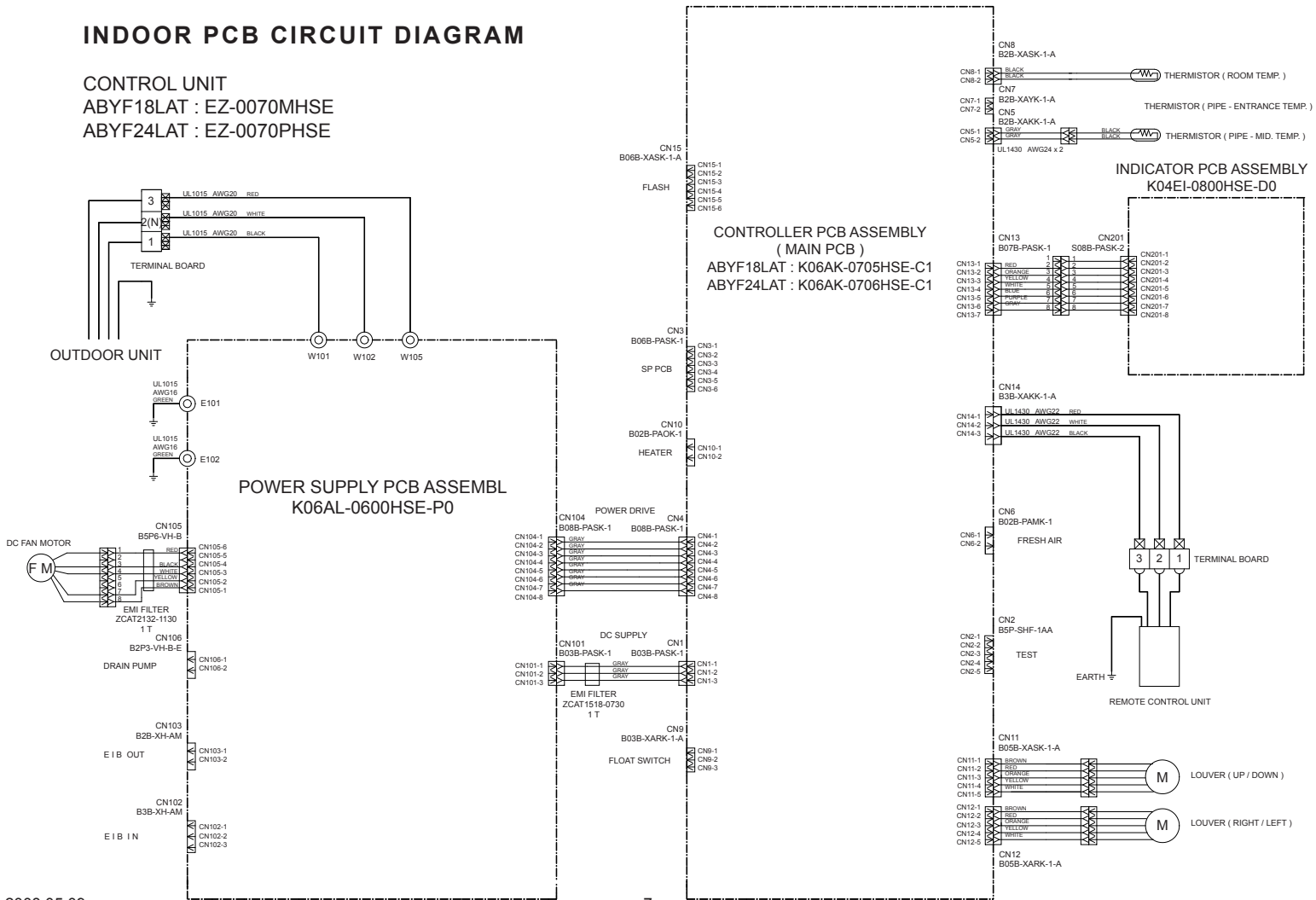



INDOOR UNIT  
 CONTROLLER PCB ASSEMBLY ( MAIN PCB )  
 ABYF18LAT : K06AK-0705HSE-C1  
 ABYF24LAT : K06AK-0706HSE-C1

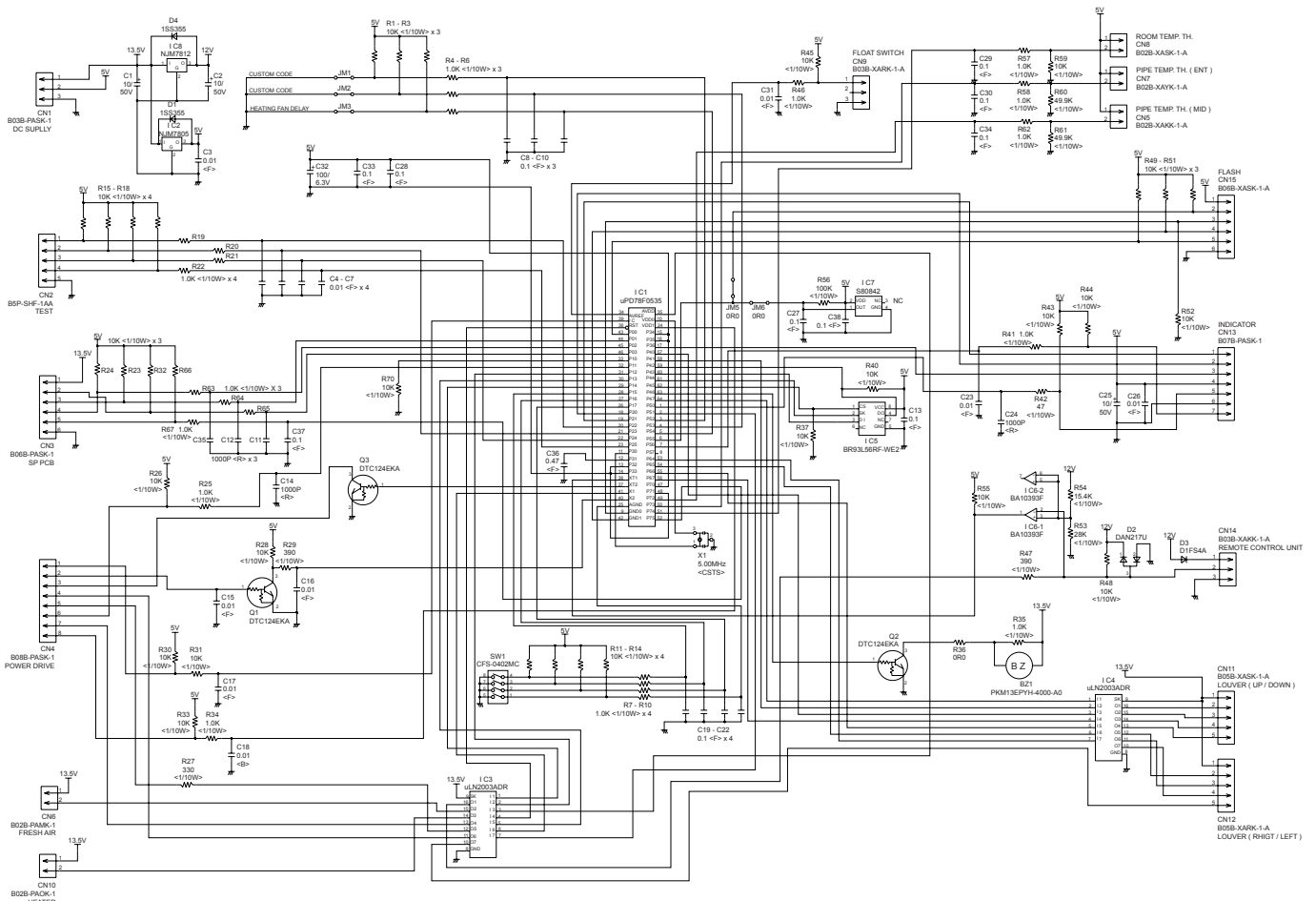

INDOOR UNIT  
POWER SUPPLY PCB ASSEMBLY  
K06AL-0600HSE-P0

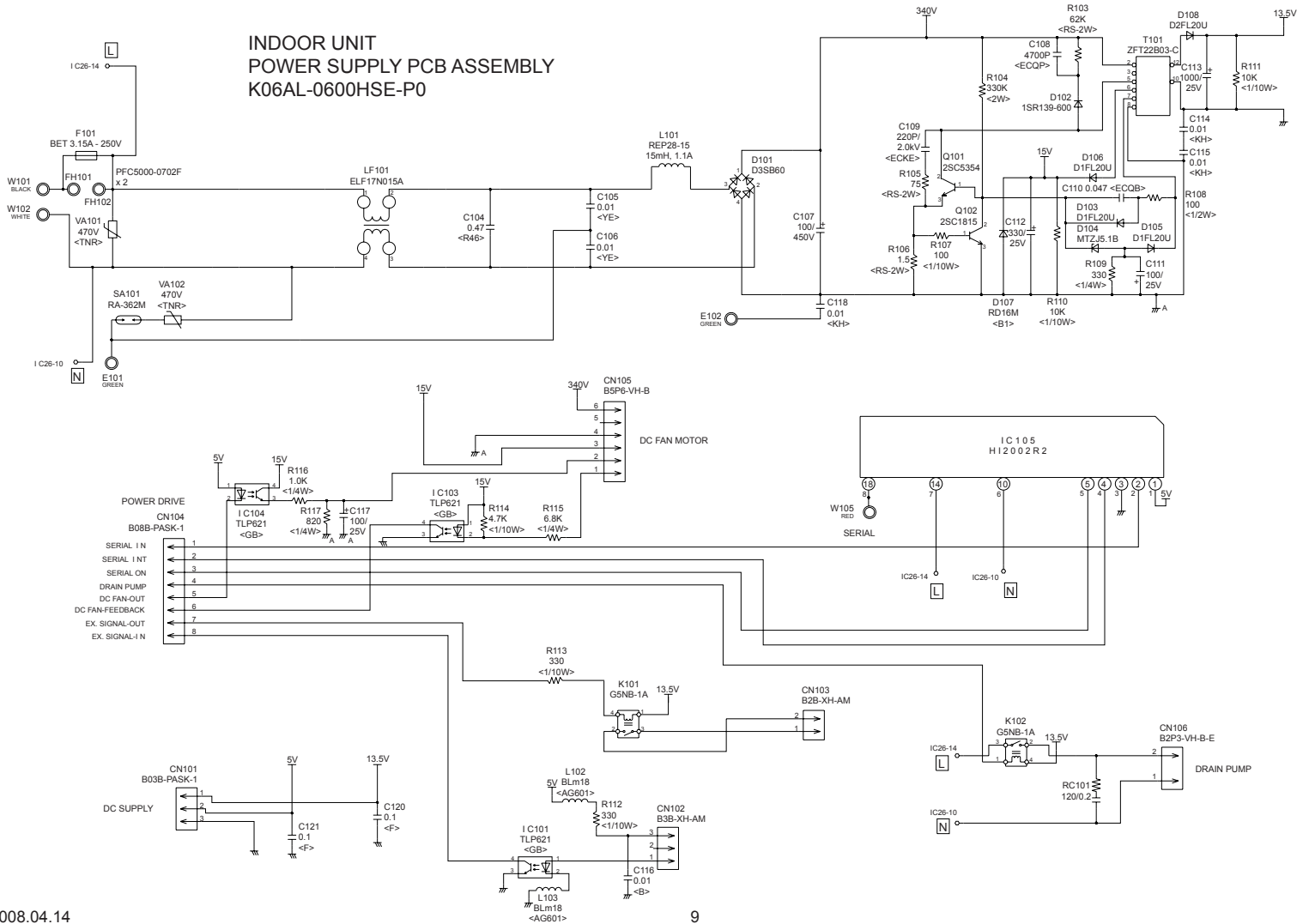

INDOOR UNIT  
 INDICATOR PCB ASSEMBLY  
 K04EI-0800HSE-D0

TO MAIN PCB

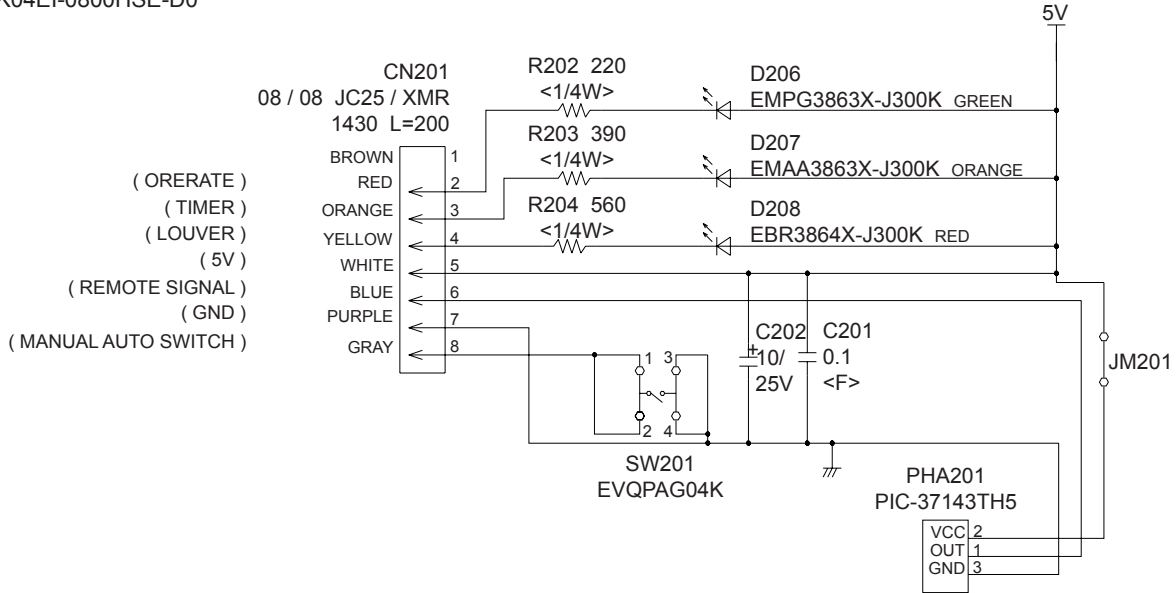

# OUTDOOR PCB CIRCUIT DIAGRAM

INVERTER ASSY  
 AOYA18LA\_L : EZ-0069HUE  
 AOYA24LA\_L : EZ-006AHUE

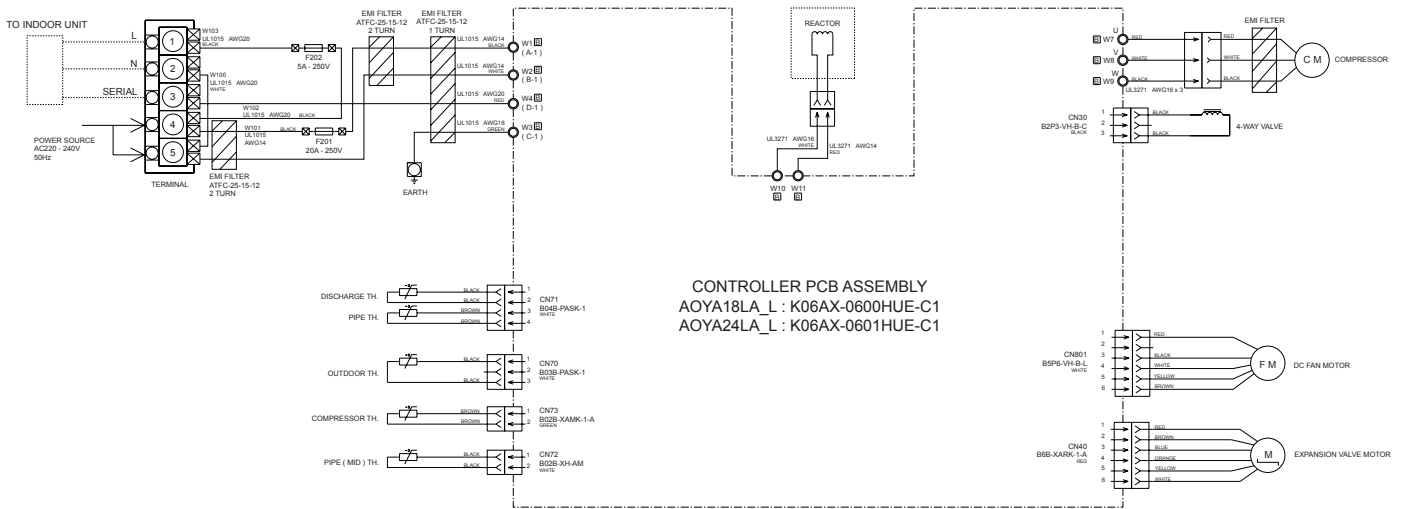

OUTDOOR UNIT  
 CONTROLLER PCB ASSEMBLY  
 AOYA18LA\_L : K06AX-0600HUE-C1  
 AOYA24LA\_L : K06AX-0601HUE-C1

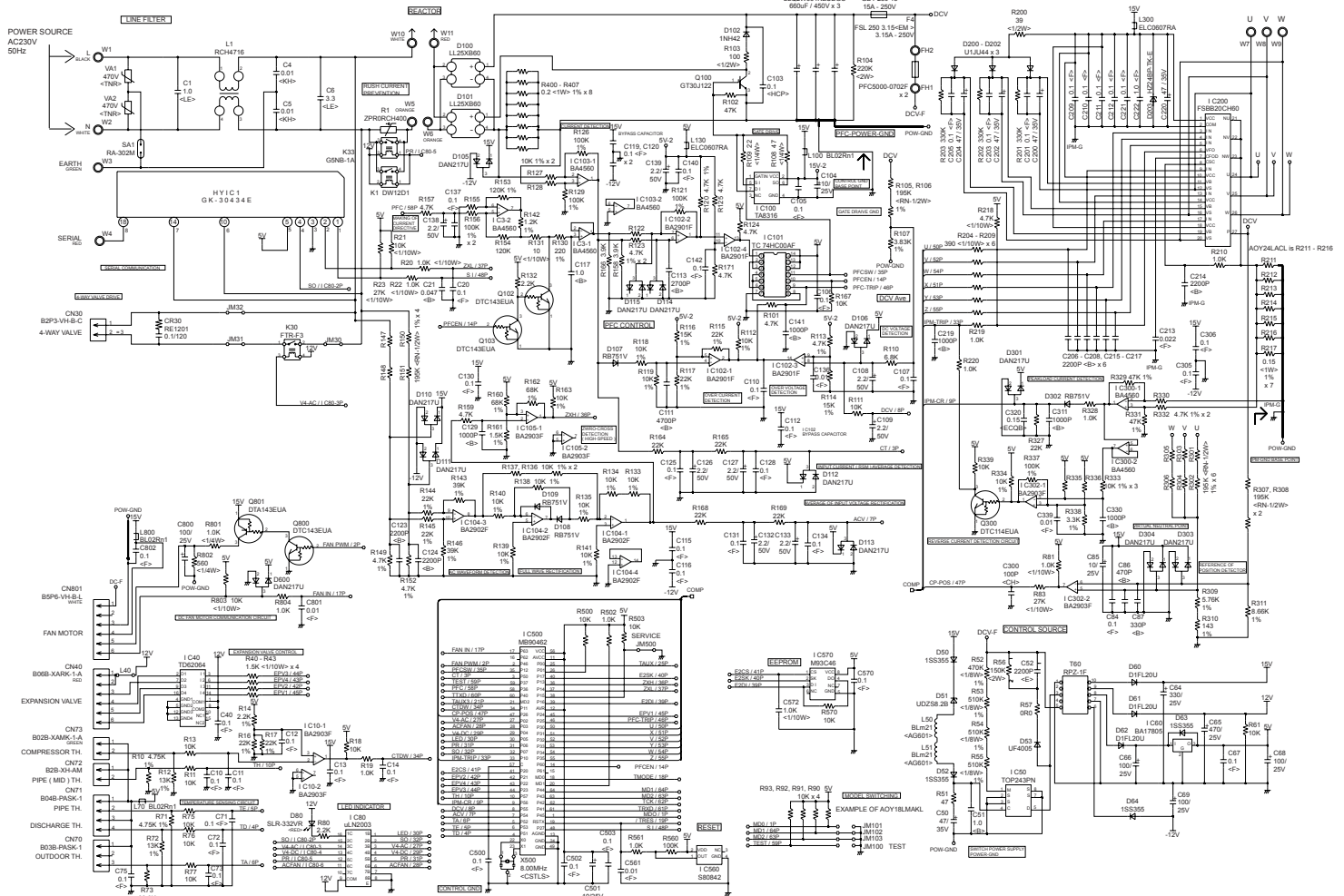

# ERROR CONTENTS

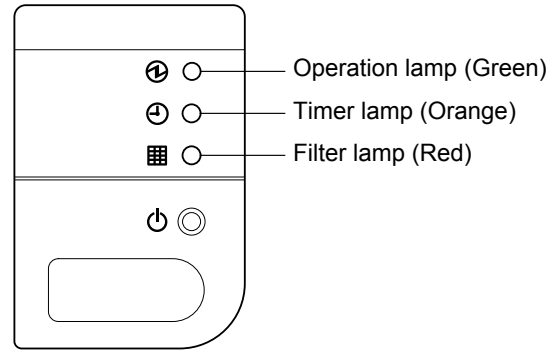

## INDOOR UNIT

The lamps show the error contents.

○ : 0.5s ON/0.5s OFF (Flash) × : OFF

Operation lamp (Green)	Timer lamp (Orange)	Filter lamp (Red)	Error contents
×	2 times ○	×	Serial reverse transfer error at starting up operation
×	3 times ○	×	Serial reverse transfer error during the operation
×	4 times ○	×	Serial forward transfer error at starting up operation
×	5 times ○	×	Serial forward transfer error during the operation
×	6 times ○	×	Communication error ( Main PCB → Display PCB )
×	7 times ○	×	Communication error ( Display PCB → Main PCB )
×	8 times ○	×	Wired remote control abnormal
2 times ○	2 times ○	×	Indoor room temperature sensor error
2 times ○	3 times ○	×	Indoor heat exchanger temperature sensor (middle) error
2 times ○	4 times ○	×	Indoor heat exchanger temperature sensor (inlet) error
2 times ○	6 times ○	×	Float switch operated
3 times ○	2 times ○	×	Outdoor discharge pipe temperature sensor error
3 times ○	3 times ○	×	Outdoor heat exchanger temperature sensor (outlet) error
3 times ○	4 times ○	×	Outdoor temperature sensor error
3 times ○	8 times ○	×	Compressor temperature sensor error
3 times ○	×	2 times ○	2-way valve temperature sensor error
3 times ○	×	3 times ○	3-way valve temperature sensor error
3 times ○	×	4 times ○	Outdoor heat exchanger temperature sensor (middle) error
4 times ○	2 times ○	×	Indoor manual auto switch abnormal
5 times ○	2 times ○	×	IPM protection
5 times ○	3 times ○	×	CT error
5 times ○	5 times ○	×	Compressor location error
5 times ○	6 times ○	×	Outdoor fan error
5 times ○	7 times ○	×	Connected indoor unit abnormal
5 times ○	8 times ○	×	Outdoor unit computer communication error
6 times ○	2 or 3 times ○	×	Indoor fan abnormal
7 times ○	2 times ○	×	Discharge temperature error
7 times ○	3 times ○	×	Excessive high pressure protection on cooling
7 times ○	4 times ○	×	4-way valve abnormal
7 times ○	5 times ○	×	Pressure switch abnormal
7 times ○	6 times ○	×	Compressor temperature error
8 times ○	2 or 3 times ○	×	Active filter abnormal
8 times ○	4 times ○	×	PFC circuit error
0.1 second flashing			Model appreciation error

## WIRED REMOTE CONTROL

If an error occurs, the following display will be shown.  
("EE" will appear in the set room temperature display.)

If "CO" appears in the unit number display, there is a remote control error.  
Refer to the installation instruction sheet included with the remote control.

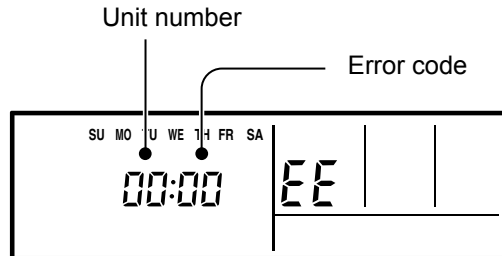

Error code	Error contents
01	Serial reverse transfer error
13	Serial forward transfer error
26	Communication error ( Main PCB → Display PCB )
27	Communication error ( Display PCB → Main PCB )
00	Wired remote control abnormal
02	Indoor room temperature sensor error
04	Indoor heat exchanger temperature sensor (middle) error
28	Indoor heat exchanger temperature sensor (inlet) error
09	Float switch operated
0C	Outdoor discharge pipe temperature sensor error
06	Outdoor heat exchanger temperature sensor (outlet) error
0A	Outdoor temperature sensor error
15	Compressor temperature sensor error
1d	2-way valve temperature sensor error
1E	3-way valve temperature sensor error
29	Outdoor heat exchanger temperature sensor (middle) error
20	Indoor manual auto switch abnormal
17	IPM protection
18	CT error
1A	Compressor location error
1b	Outdoor fan error
1F	Connected indoor unit abnormal
1c	Outdoor unit computer communication error
12	Indoor fan abnormal
0F	Discharge temperature error
24	Excessive high pressure protection on cooling
2c	4-way valve abnormal
16	Pressure switch abnormal
2b	Compressor temperature error
19	Active filter abnormal
25	PFC circuit error
11	Model appreciation error

Outdoor unit

<b>Error contents</b>	<b>LED</b>
Thermistor malfunction	on 0.1 sec / off 0.1 sec
Abnormal discharge temperature	on
Current surge protection	on 0.5 sec / off 0.5 sec
CT abnormality	on 2.0 sec / off 2.0 sec
Compressor position detection malfunction	on 0.1 sec / off 2.0 sec
Fan malfunction	on 5.0 sec / off 5.0 sec
PAM voltage abnormality	on 5.0 sec / off 0.1 sec
Timer short	on 1.0 sec / off 1.0 sec
Compressor temperature protection (permanent stop)	on 2.0 sec / off 5.0 sec
PFC surge protection (permanent stop)	on 5.0 sec / off 2.0 sec



# PARTS

## INDOOR UNIT

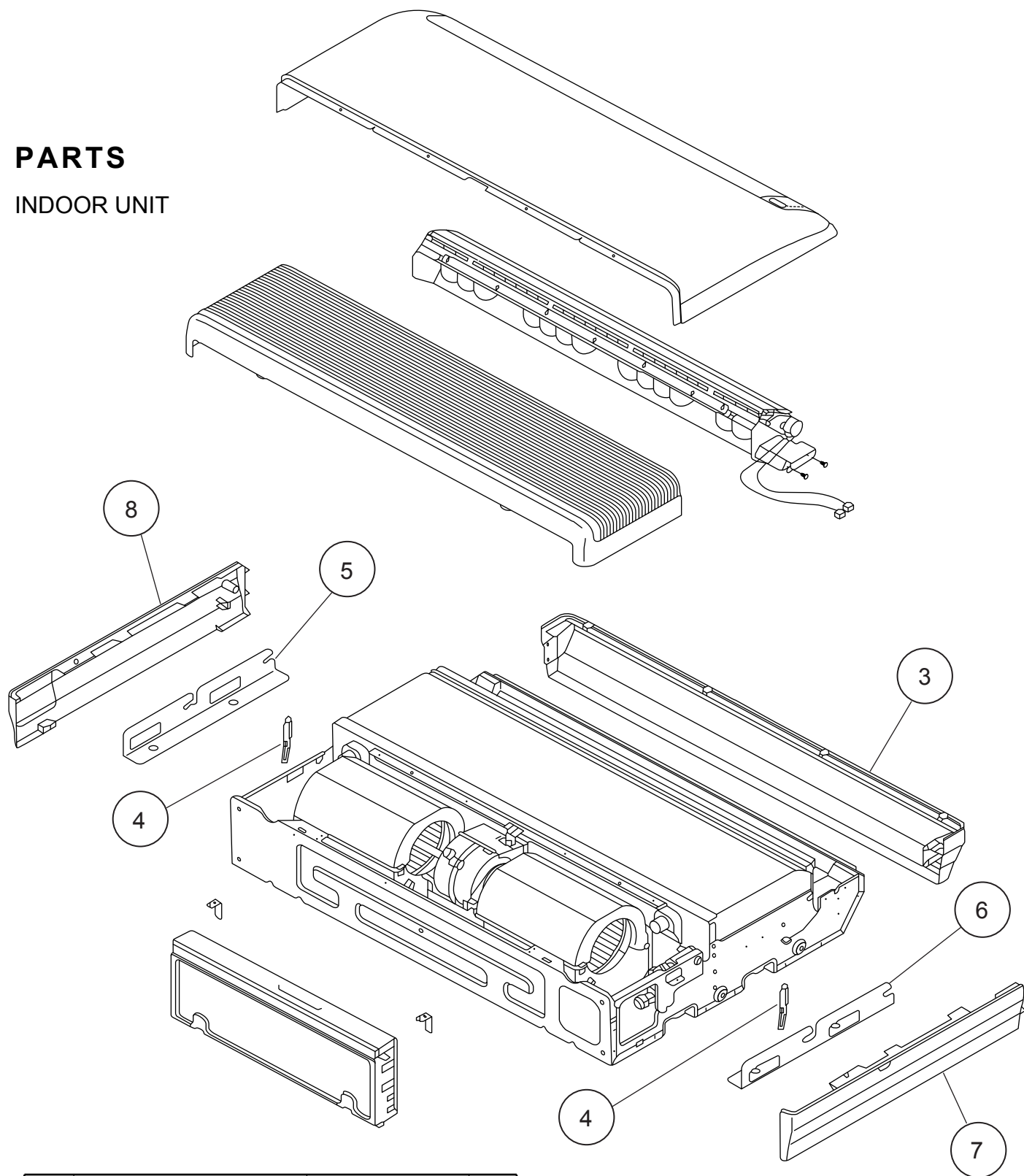

Ref.	Description	Part number
1	Remote Control	9315885012
2	Remote Control Holder	9305642045
3	Top Cover	9358534014
4	Arm	9358565001
5	Hanger Bracket L	9358596005
6	Hanger Bracket R	9358595008
7	Cosmetic Panel R	9358535011
8	Cosmetic Panel L	9358536018

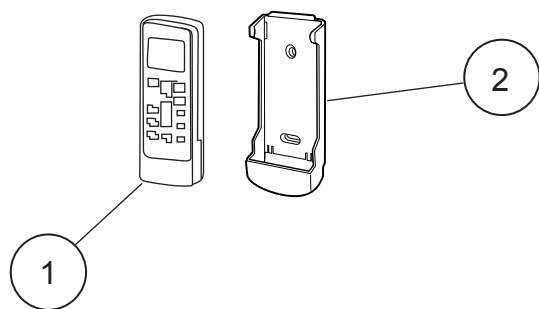

INDOOR UNIT  
Panel assy

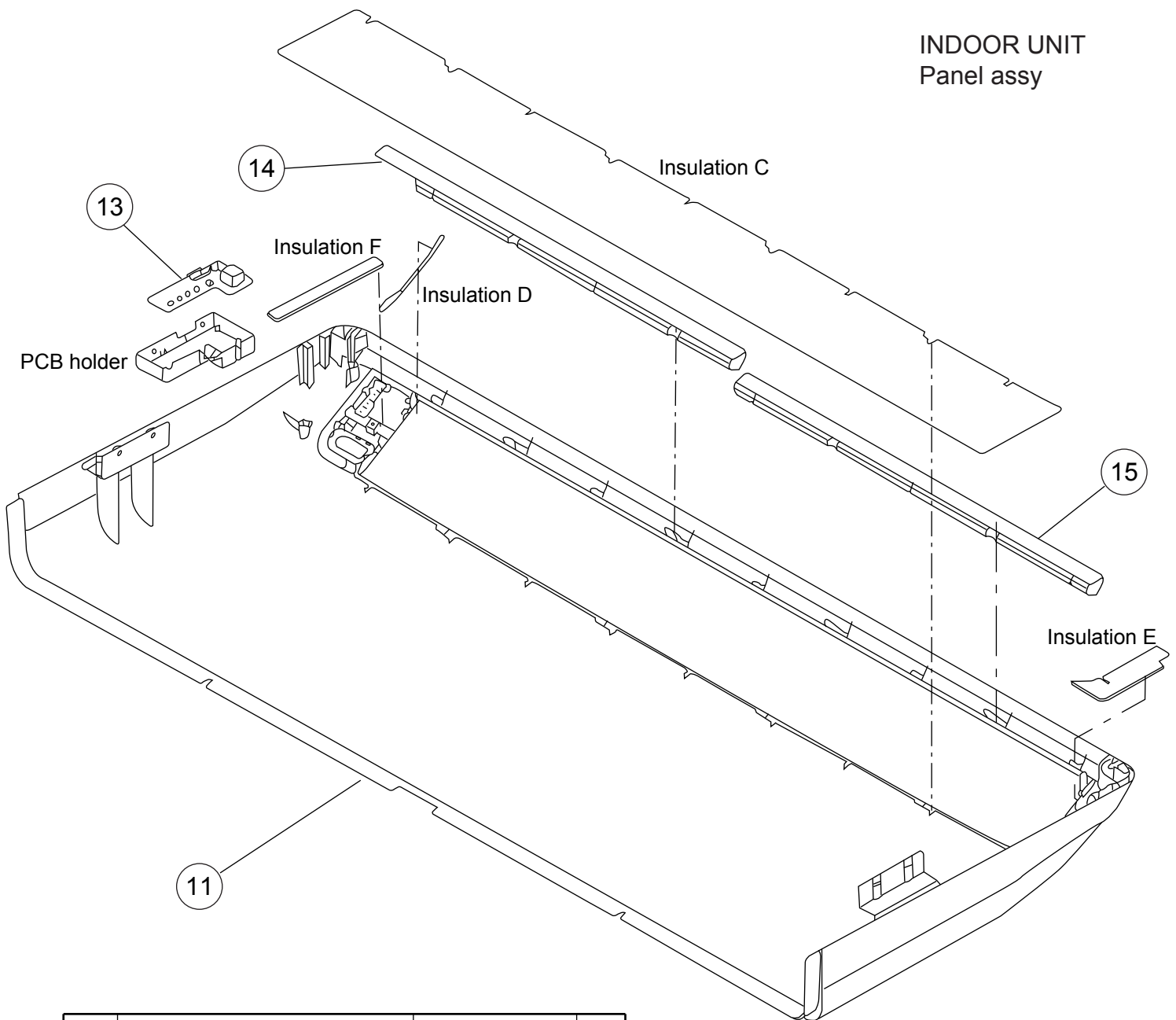

Ref.	Description	Part number
11	Panel	9358531150
12	Side Cover R Assy	9359069041
13	Indicator PCB Assy	9705798052
14	Insulation (Panel) A	9358574003
15	Insulation (Panel) B	9358914007
--	Panel Assy (with side cover R)	9359076186

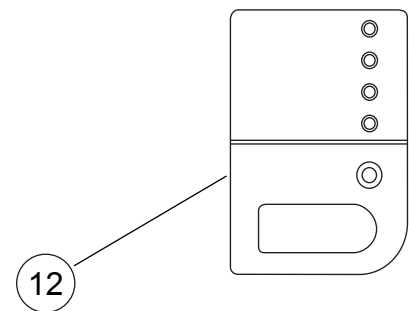

INDOOR UNIT  
Grille

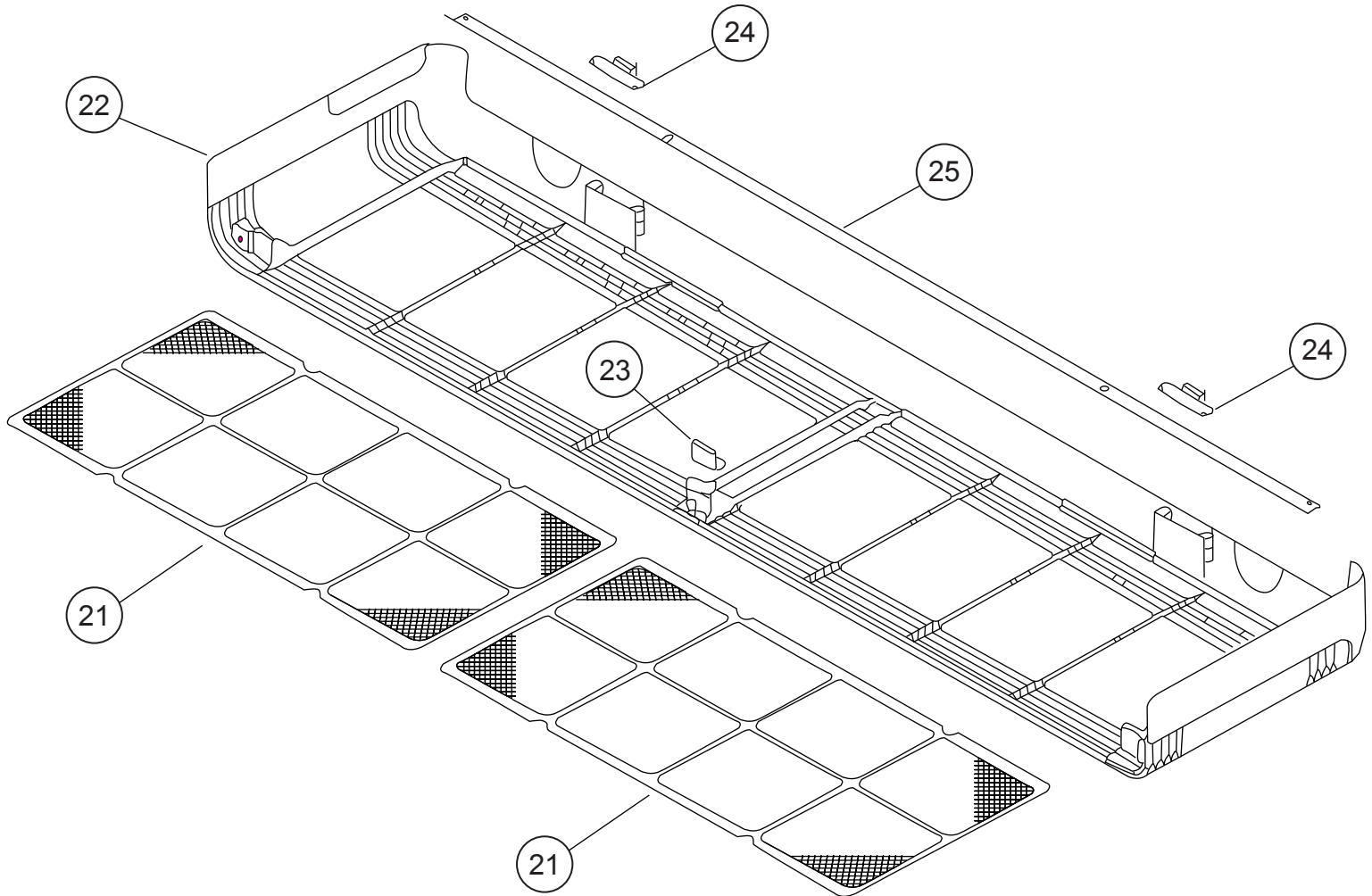

Ref.	Description	Part number	
21	Air Filter	9358567029	
22	Grill F	9358532010	
23	Arm Bracket	9359281009	
24	Grille Support	9358602003	
25	Filter Bracket	9358607008	

INDOOR UNIT  
Kit (Flap base)

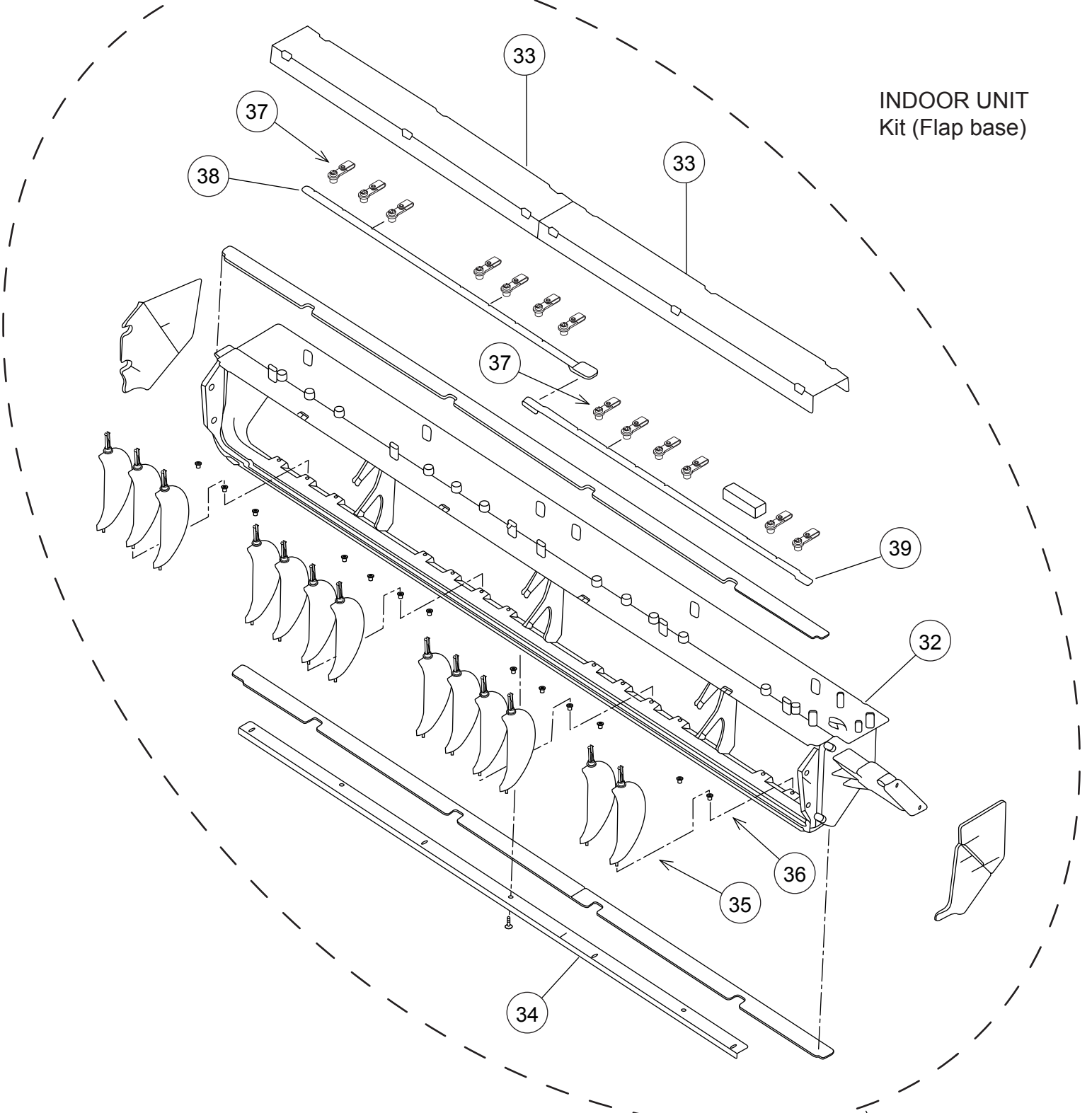

Ref.	Description	Part number
31	Kit (Flap Base)	9372670019
32	Flap Base	9358537015
33	Protect Cover	9358564004
34	Support Stay	9358599006
35	Louver	9358561010
36	Bushing B	9358554005
37	Louver Stopper	9358555002
38	Louver Rod	9358559000
39	Motor Rod	9358560006

INDOOR UNIT  
Flap base sub assy

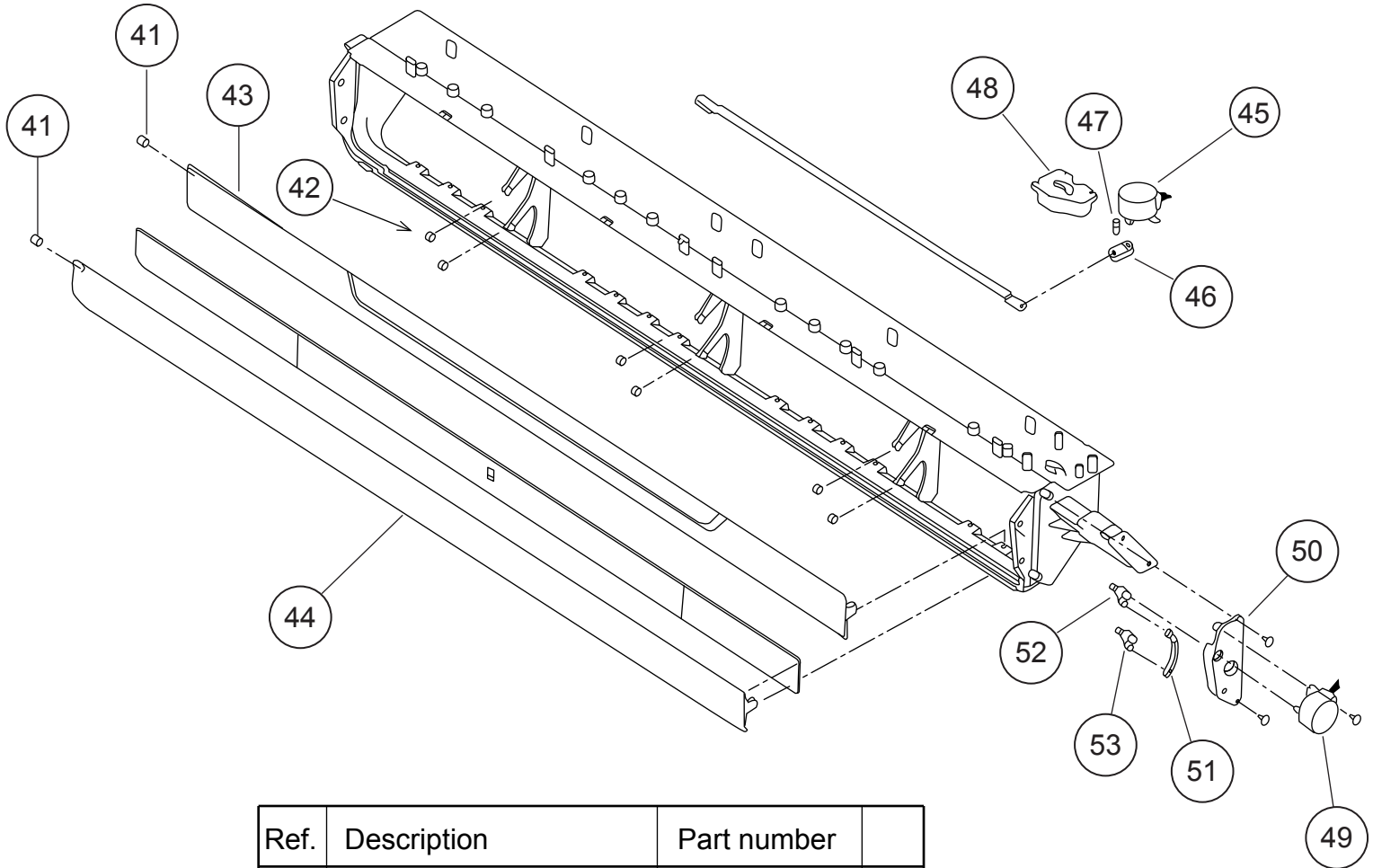

Ref.	Description	Part number	
41	Bushing	9357942001	
42	Bushing C	9358553008	
43	Flap (Upper) F	9358538012	
44	Kit (Flap Lower)	9372671016	
45	Step Motor H	9900297015	
46	Louver Link	9358556009	
47	Louver Shaft	9358557006	
48	Louver Link Cover	9358558003	
49	Step Motor-V	9900362010	
50	Motor Base	9358562000	
51	Motor Rod-A (Step V)	9358550007	
52	Flap Link-Upper (Step V)	9358551004	
53	Flap Link-Lower (Step V)	9358552001	

INDOOR UNIT  
Base assy

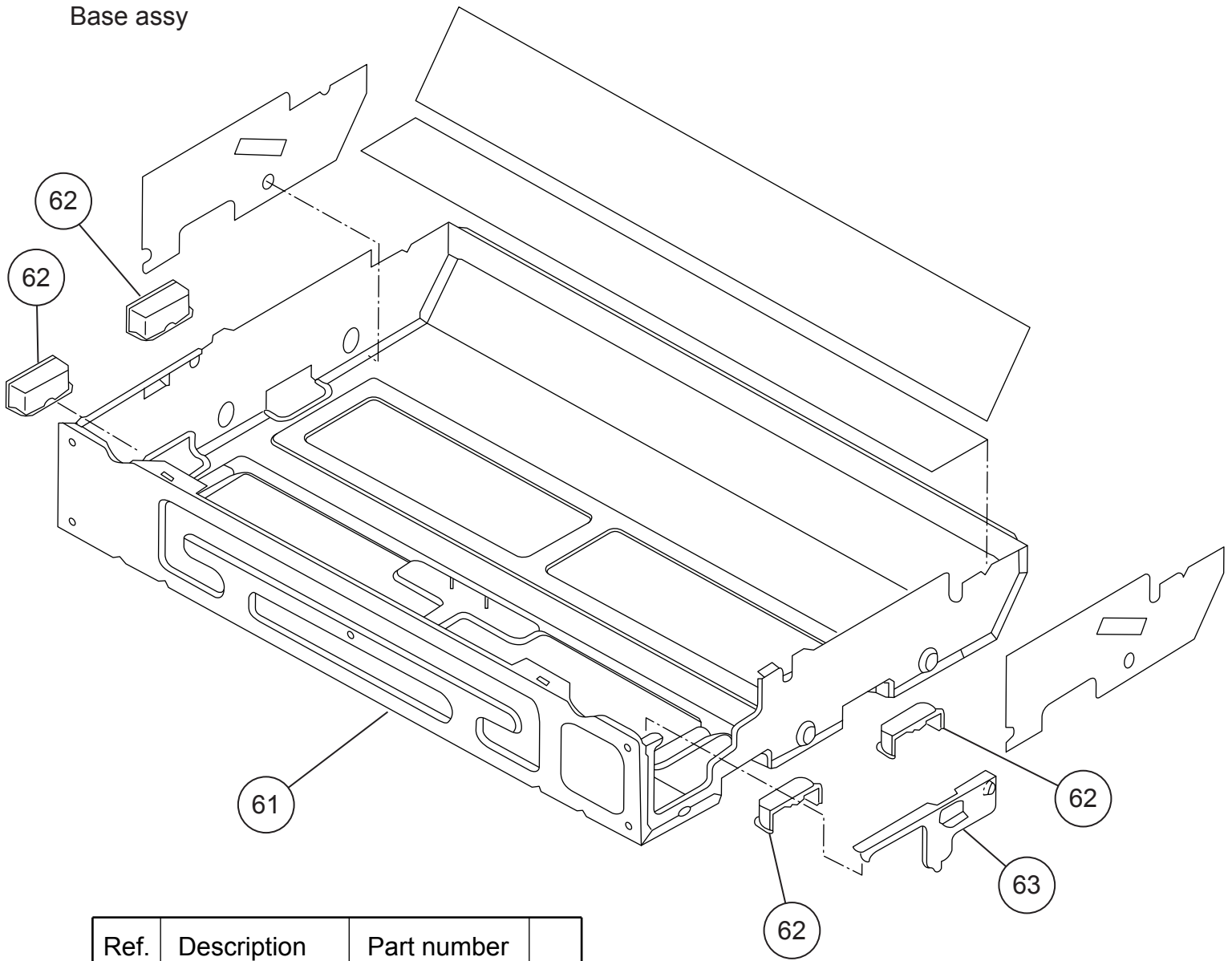

Ref.	Description	Part number	
61	Base Assy	9359061014	
62	Cap	9358563007	
63	Base Bracket	9358586006	

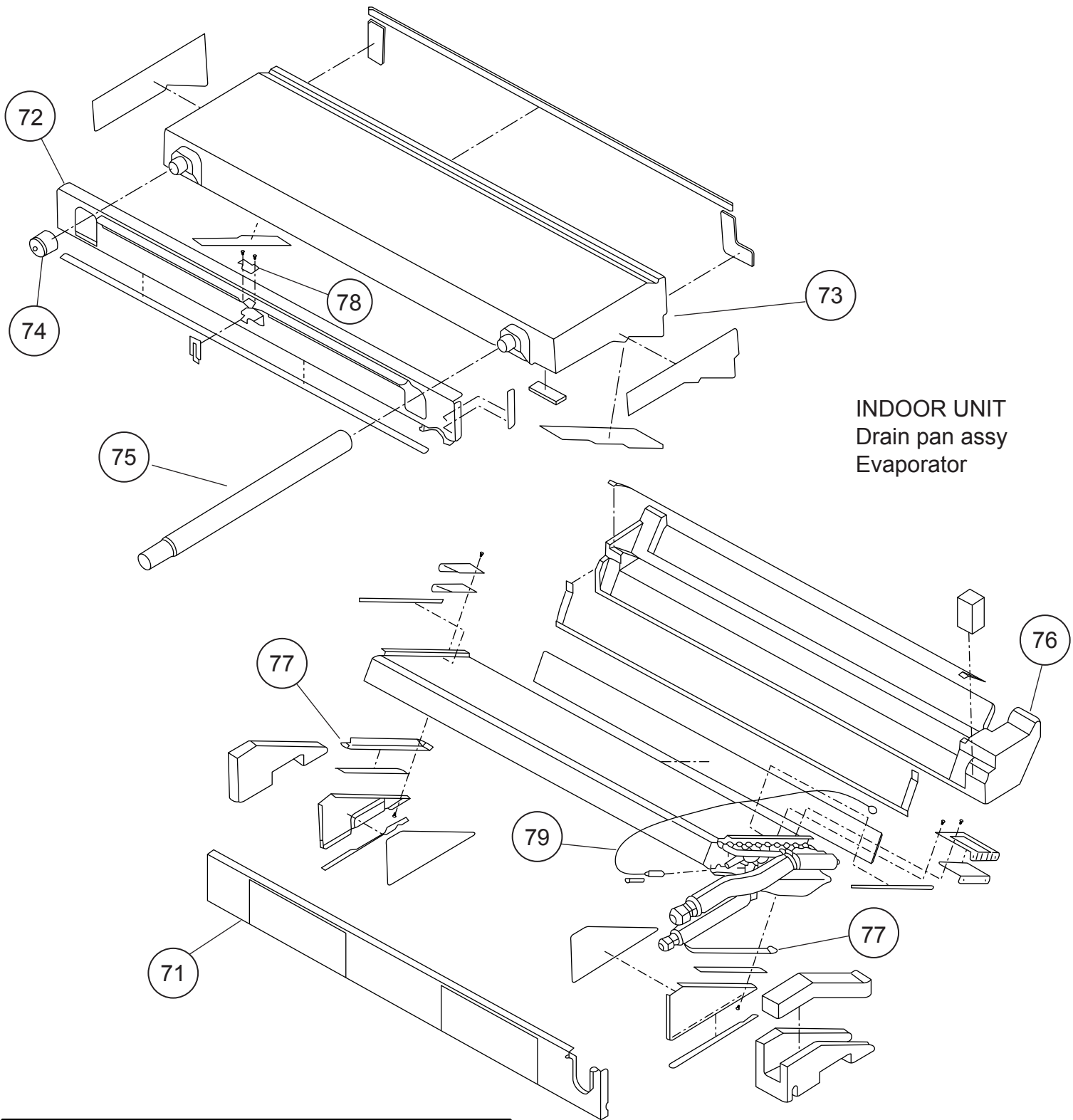

INDOOR UNIT  
 Drain pan assy  
 Evaporator

Ref.	Description	Part number
71	Kit (Separate Wall A)	9372666012
72	Kit (Separate Wall B)	9373448013
73	Kit (Drain Pan Assy)	9372669013
74	Drain Cap	9358746004
75	Drain Hose Assy	9359242000
76	Kit (Insulation Flap Base)	9372672013
77	Kit (Dew Proof Plate)	9372673010
78	Catch	9359096009
79	Pipe Thermistor	9900022020

INDOOR UNIT  
 ABYF18LAT  
 Evaporator

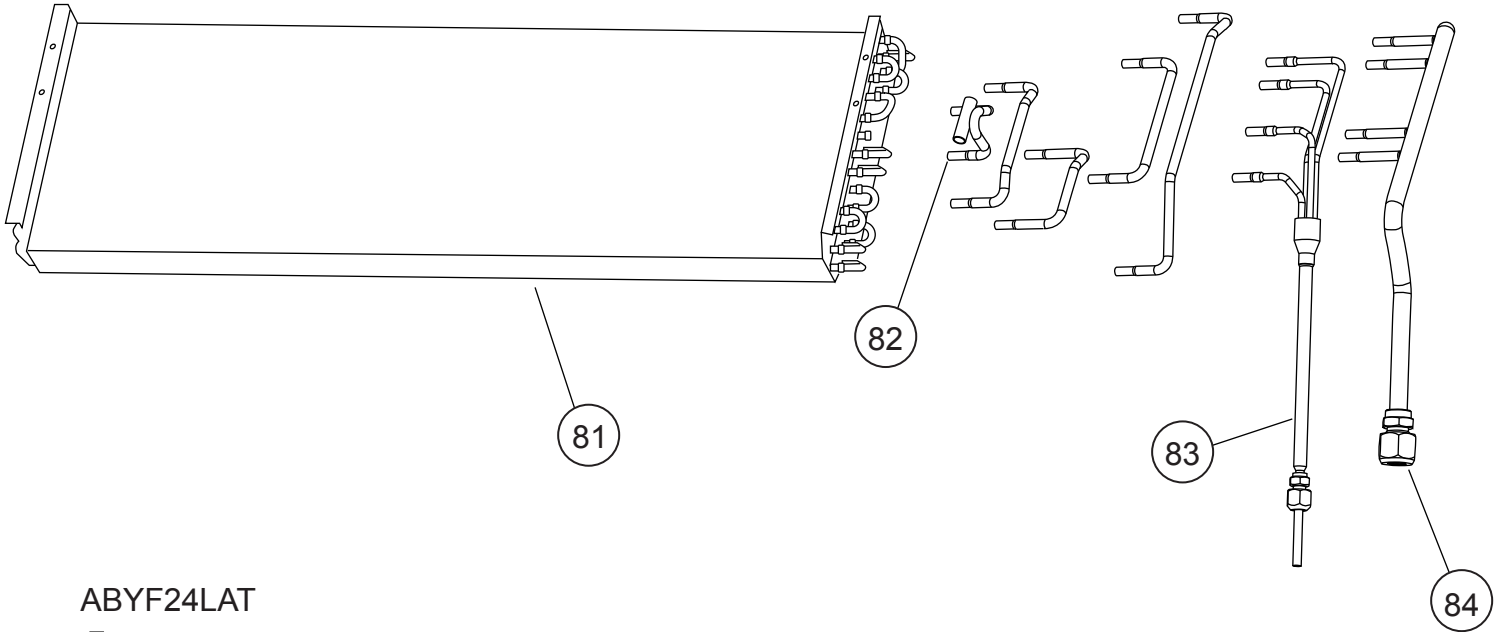

ABYF24LAT

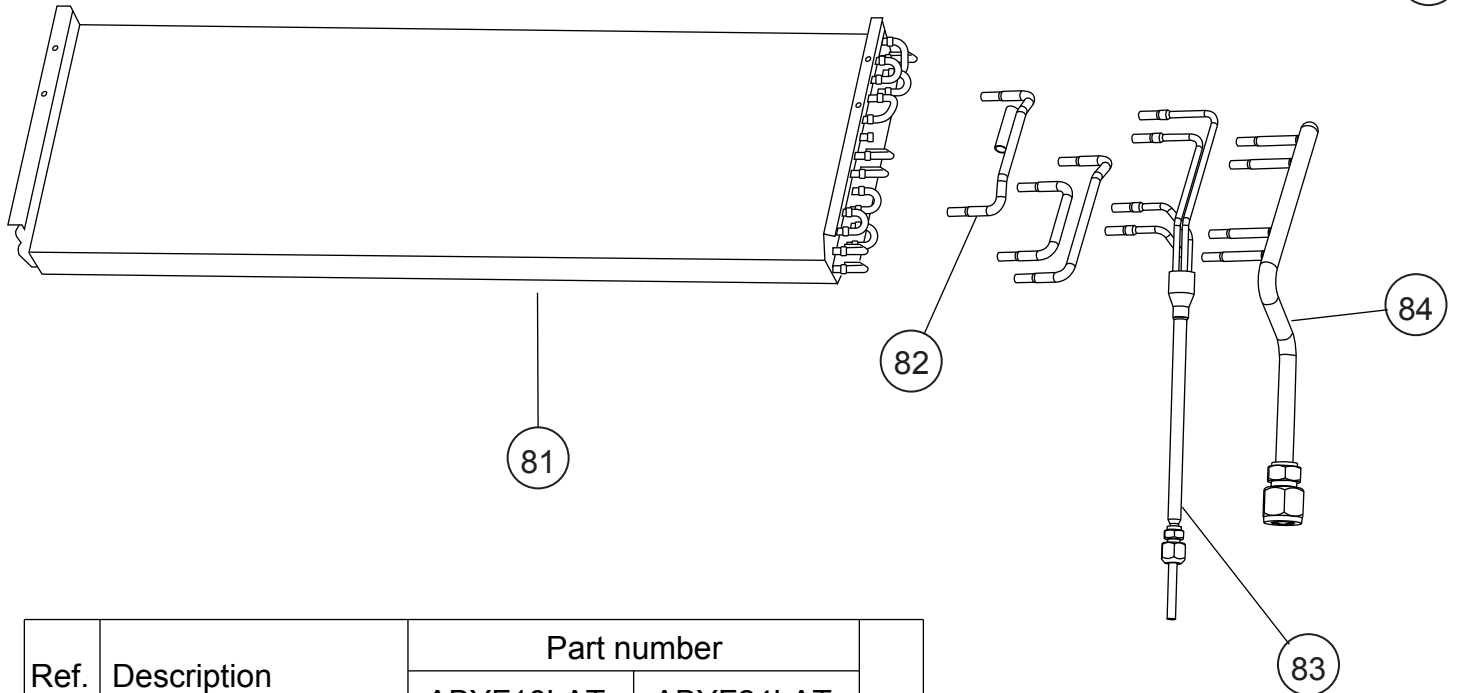

Ref.	Description	Part number	
		ABYF18LAT	ABYF24LAT
81	Evaporator Assy	9362513043	9362513050
82	Bypass Pipe Assy	9377819017	9377821010
83	Distributor Assy	9371325354	9371325361
84	Coupling Pipe Assy	9373038382	9373038399



INDOOR UNIT  
Fan motor

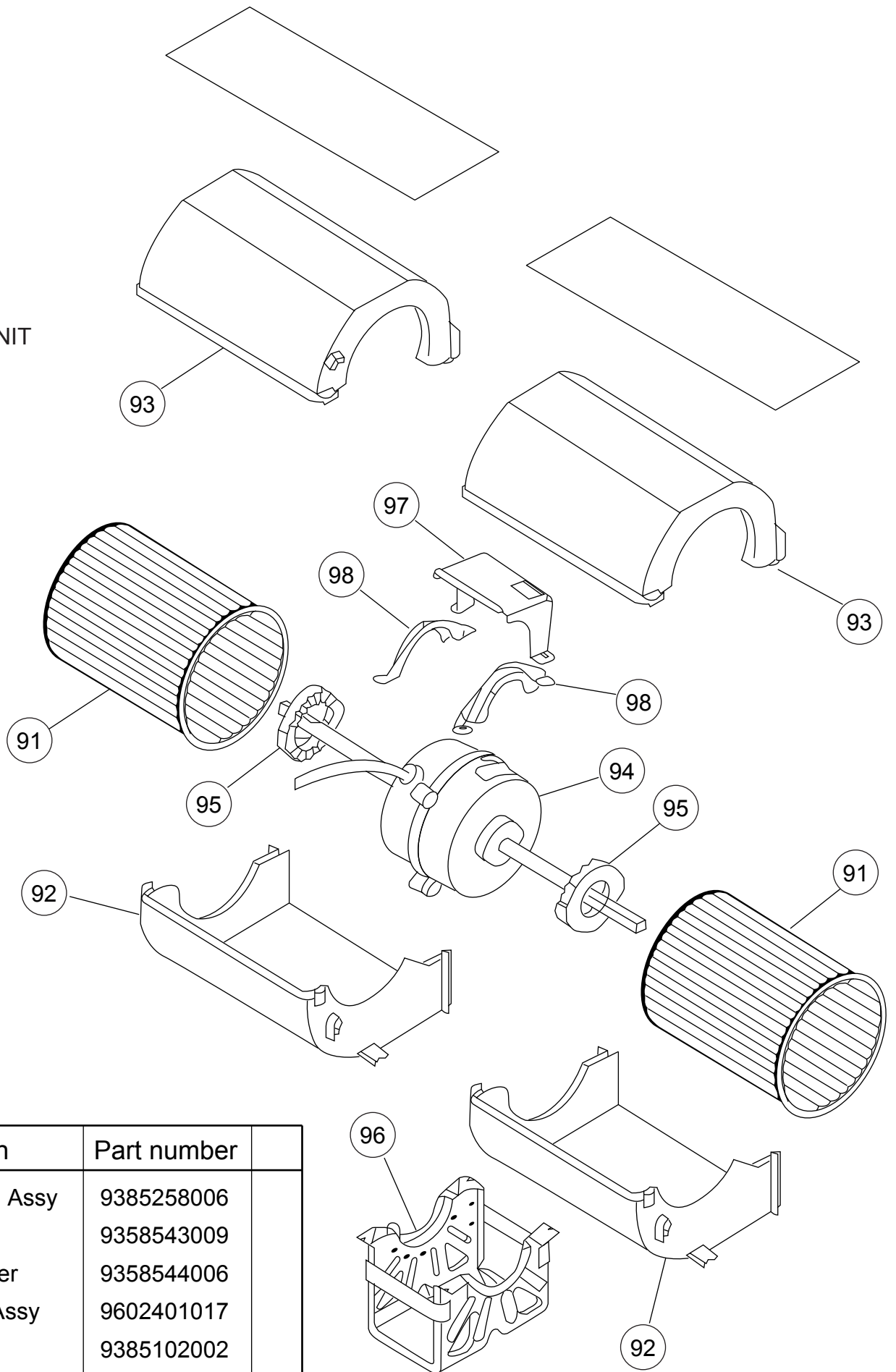

Ref.	Description	Part number
91	Sirocco Fan Assy	9385258006
92	Casing	9358543009
93	Casing Cover	9358544006
94	Fan Motor Assy	9602401017
95	Rubber	9385102002
96	Motor Fixing Table	9358591000
97	Protector	9359282006
98	Motor Fixture	9358594001

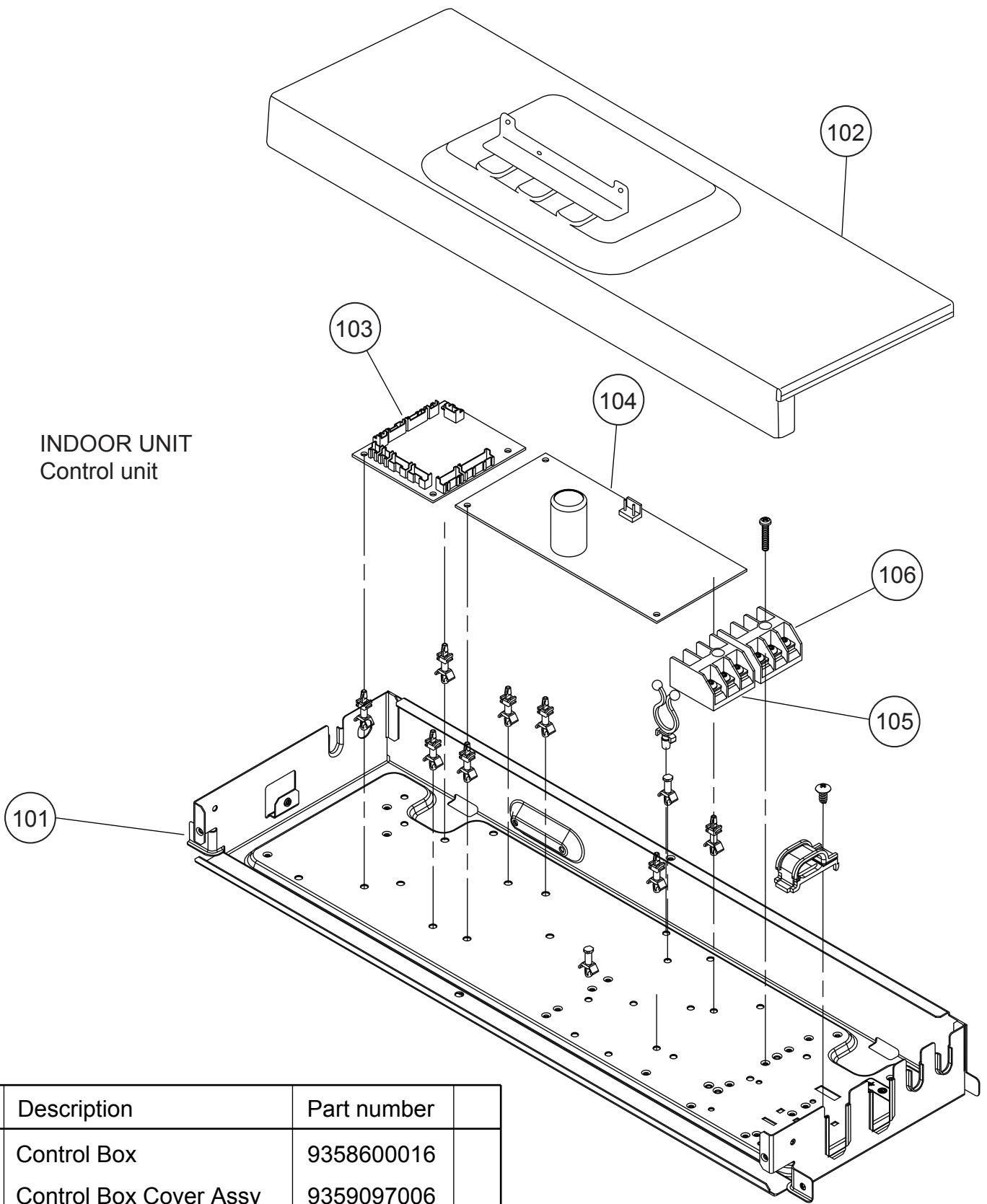

Ref.	Description	Part number
101	Control Box	9358600016
102	Control Box Cover Assy	9359097006
103	Controller PCB Assy (18)	9707393347
103	Controller PCB Assy (24)	9707393354
104	Power Supply PCB Assy	9707398014
105	Terminal 3P	9306489045
106	Terminal 3P	9703345012
--	Room Thermistor Assy	9703299087

# PARTS

## OUTDOOR UNIT

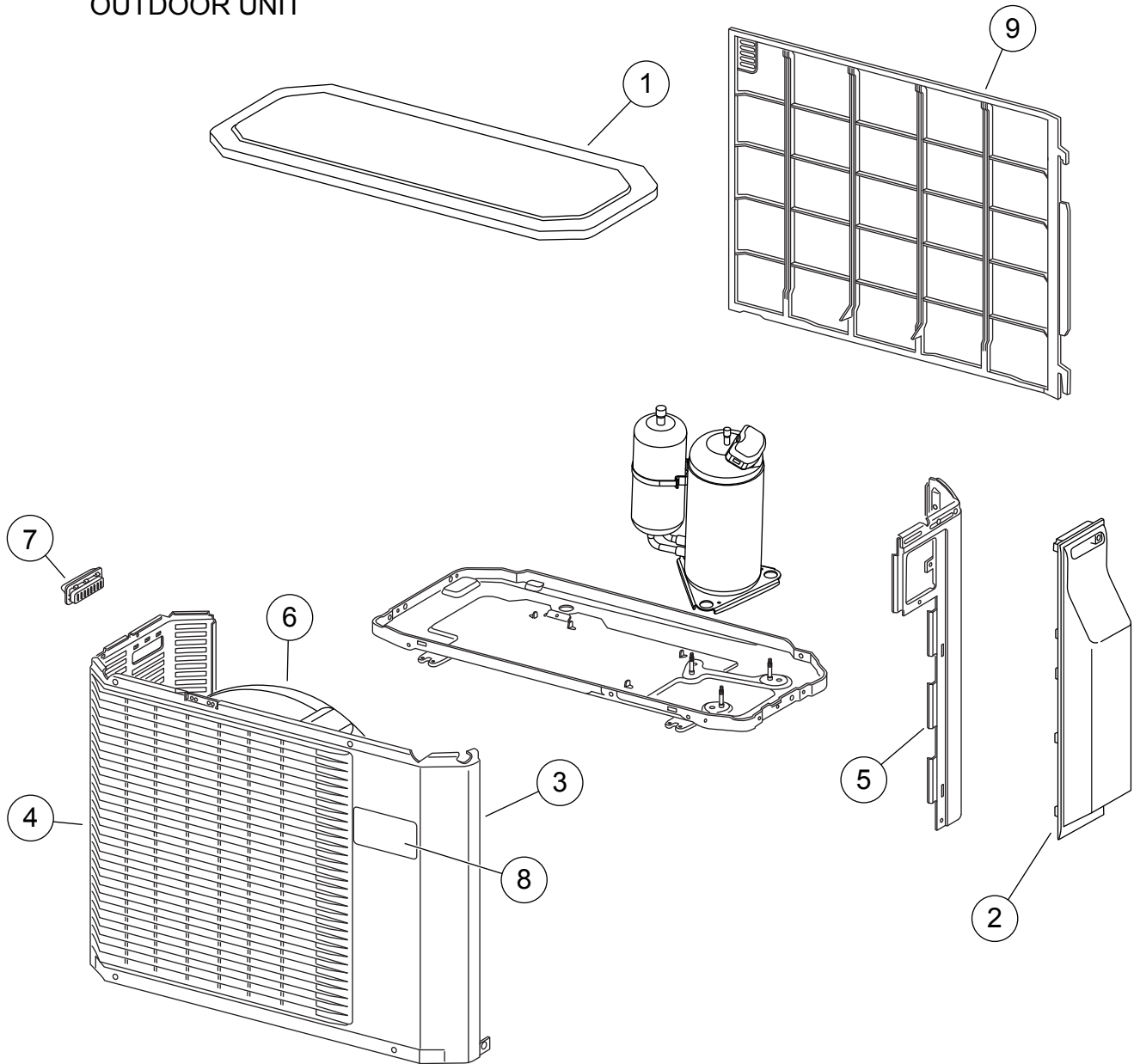

Ref.	Description	Part number	
		AOYA18LA_L	AOYA24LA_L
1	Top Panel Assy	9309230057	9309230057
2	Cover (Switch) Assy	9309237032	9309237032
3	Cabinet Assy	9314809040	9314809019
4	Blow Down Grille	9308884015	9308884015
5	Cabinet Right Assy	9309236011	9309236028
6	Fan Ring	9308885012	9308885012
7	Grip	9308880017	9308880017
8	Emblem	9315210012	9315210012
9	Protective Net	9315319012	9315033017

# OUTDOOR UNIT

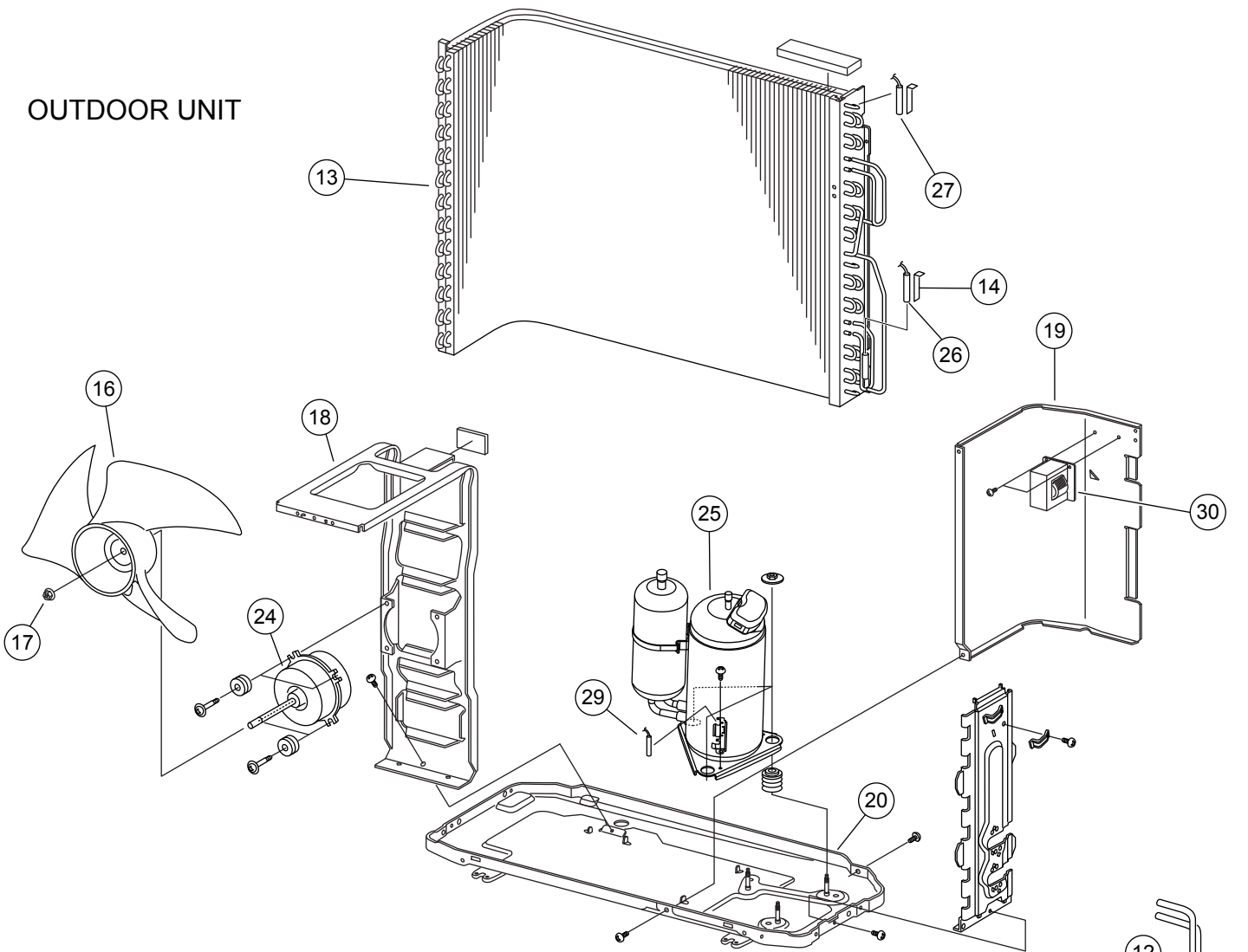

Ref.	Description	Part number	
		AOYA18LA_L	AOYA24LA_L
11	4-Way Valve	9900047016	9900163013
12	Pulse Motor Valve Assy	9311641018	9315310019
13	Condenser Assy	9311382027	9315302014
14	Thermistor Spring A	313728262708	313728262708
15	Thermistor Spring	9300089012	9357804002
16	Propeller Fan	9309909014	9309909014
17	Nut	9304902003	9304902003
18	Motor Bracket	9308872012	9308872029
19	Separator Assy	9312971015	9312971015
20	Base Assy	9308869081	9315296030
21	3-Way Valve Assy	9315159014	9315414014
22	2-Way Valve Assy	9313064013	9313062019
23	Expansion Valve Coil	9900057039	9900057039
24	Fan Motor	9602133017	9602451012
25	Compressor Assy	9313763039	9315297037
26	Thermistor Assy	9900148027	9900148027
27	Heat Exchanger Thermistor	9900403010	9900403010
28	Solenoid Coil	9970033018	9970055010
29	Compressor Thermistor	9900156046	9900156046
30	Reactor Assy	9900354015	9900354015
--	Outdoor Thermistor	9900210045	9900210045
--	Condenser Assy B	---	9315303011

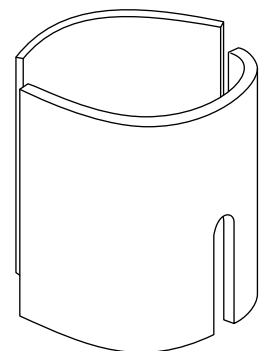
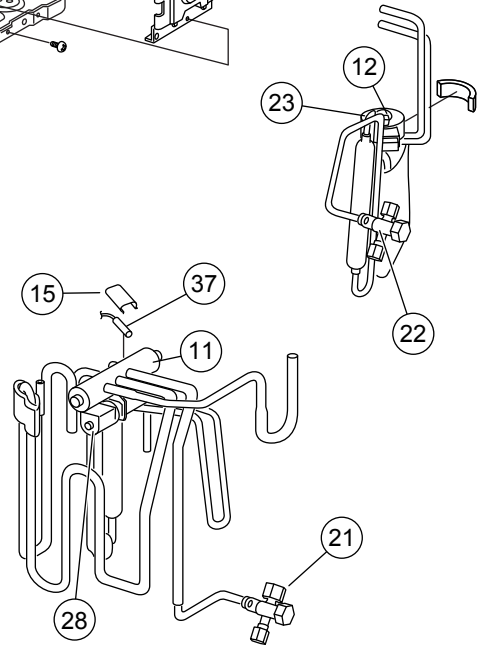



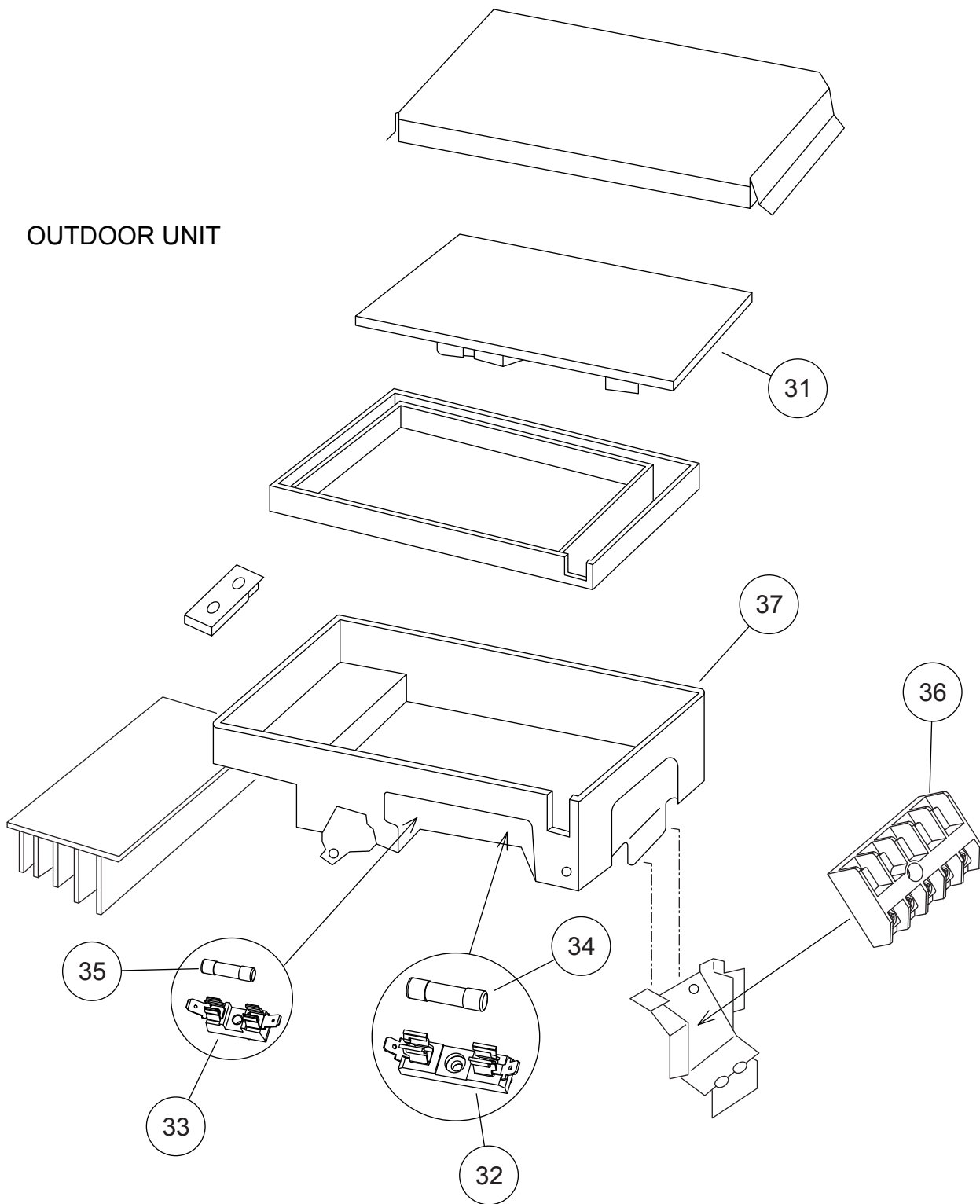







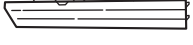

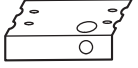
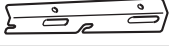
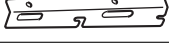





# OUTDOOR UNIT

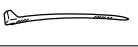

Ref.	Description	Part number	
		AOYA18LA_L	AOYA24LA_L
31	Inverter PCB Assy	9707427011	9707427028
32	Fuse Holder	0501454012	0501454012
33	Fuse Holder	0501456016	0501456016
34	Fuse	0600382018	0600382018
35	Fuse	0600372163	0600372163
36	Terminal	9703874031	9703874031
37	Inverter Case Assy	9315690012	9315690012

# ACCESSORIES

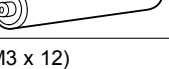
## INDOOR UNIT

Name and Shape	Q'ty	Application	Part number
Cosmetic Panel-L 	1		9358536018
Cosmetic Panel-R 	1		9358535011
Screw (M4 x 10) 	2		0700009037
Installation template 	1	For positioning the indoor unit. For under ceiling type.	9359107002
Hanger bracket (left) 	1	For suspending the indoor unit from ceiling.	9358596005
Hanger bracket- (right) 	1		9358595008
Anchor bolt (M12) 	4		313806339400
Special nut 	4		
Spring washer 	4		0700007125
Wall bracket 	2	For suspending the indoor unit on the wall.	9358597002
Screw (M4 x 20) 	6	For fixing the wall bracket.	0700076107
Coupler heat insulator (large) 	1	For indoor side pipe joint. (Large pipe)	9378173552
Coupler heat insulator (small) 	1	For indoor side pipe joint. (Small pipe)	9378173736
Nylon fastener 	1	For fixing the drain hose.	312300787605
Drain hose 	1		9359242000
Insulation (drain hose) 	1	Adhesive type 70 x 230	9359225003
VT wire 	1	For fixing the drain hose L 280 mm	313806350303
Remote control 	1	For air conditioner operation	9315885012
Remote control holder 	1	For installing remote control on the wall	9305642045
Battery 	2	For remote control	0600185541
Screw (M3 x 12) 	2	For mounting the remote control holder	0700019098

#### OUTDOOR UNIT

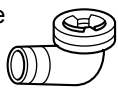
Name and Shape	Q'ty	Application	Part number
Drain pipe 	1	For drain piping work.	9303029015

#### OPTIONAL PARTS

Wired remote control : UTB-YUD (P/N 9076961000)

0805G3485