

**INVERTER MULTI
AIR CONDITIONER
CASSETTE type**

SERVICE MANUAL



Models

Indoor unit

Outdoor unit

AUY12LBAB	}	AOY18LMAK2
AUY14LBAB		

CONTENTS

SPECIFICATIONS	1
OUTLINE AND DIMENSIONS	2
REFRIGERANT SYSTEM DIAGRAM	4
CIRCUIT DIAGRAM	5
INDOOR PCB CIRCUIT DIAGRAM	7
OUTDOOR PCB CIRCUIT DIAGRAM	8
ERROR CONTENTS	9
DISASSEMBLY ILLUSTRATION	10
PARTS LIST	17

SPECIFICATIONS

TYPE	COOL & HEAT	
INDOOR UNIT	AUY12LBAB	AUY14LBAB
OUTDOOR UNIT	AOY18LMAK2	

ELECTRICAL DATA (INDOOR UNIT)

COOLING CAPACITY	(kW)	3.3	4.0
HEATING CAPACITY	(kW)	3.7	4.2
MOISTURE REMOVAL	(ℓ /hr)	1.2	1.5
AIR CIRCULATION-Hi	(m ³ /hr)	550	

ELECTRICAL DATA (OUTDOOR UNIT)

POWER SOURCE	(V)	230	
FREQUENCY	(Hz)	50	
COOLING CAPACITY (MAX)	(kW)	5.5 (6.5)	
HEATING CAPACITY (MAX)	(kW)	6.4 (7.1)	
RUNNING CURRENT (MAX)	(A)	COOLING	7.5 (9.7)
		HEATING	8.0 (9.7)
INPUT WATTS (MAX)	(kW)	COOLING	1.73 (2.22)
		HEATING	1.84 (2.22)
E.E.R.	(kW / kW)	COOLING	3.18
		HEATING	3.48

COMPRESSOR

TYPE	Hermetic type, Inverter, 4 poles, Three phase, DC motor, Rotary		
DISCRIMINATION	TNB 220 FPCM		
REFRIGERANT	R410A	(g)	1,900

FAN MOTOR

POWER SOURCE	(V)	230	
INDOOR UNIT	DISCRIMINATION	MFA-14GTCT	
	HI	(r.p.m.)	730
	MED	(r.p.m.)	670
	LO	(r.p.m.)	590
OUTDOOR UNIT	(r.p.m.)	780	

DIMENSIONS

INDOOR UNIT	H x W x D	(mm)	235 x 580 x 580+70
GRILL	H x W x D	(mm)	35 x 650 x 650
OUTDOOR UNIT	H x W x D	(mm)	650 x 830 x 320

WEIGHT

INDOOR UNIT	GROSS / NET	(kg)	23 / 18
GRILL	GROSS / NET	(kg)	4.3 / 2.2
OUTDOOR UNIT	GROSS / NET	(kg)	62 / 56

NOISE LEVEL

INDOOR UNIT	HI	(dB)	42
	MED	(dB)	39
	LO	(dB)	36
OUTDOOR UNIT	COOLING	(dB)	49
	HEATING	(dB)	50

OUTLINE AND DIMENSIONS

INDOOR UNIT

(unit : mm)

Models :
AUY12LBAB
AUY14LBAB

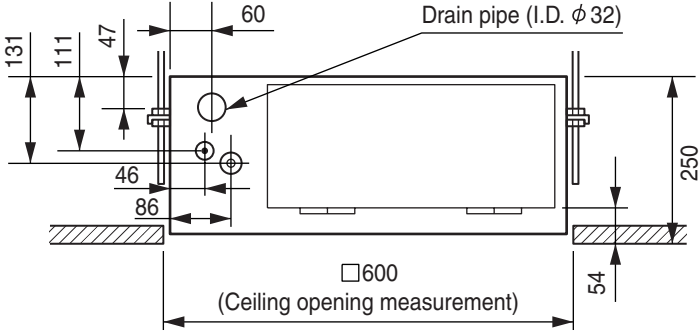
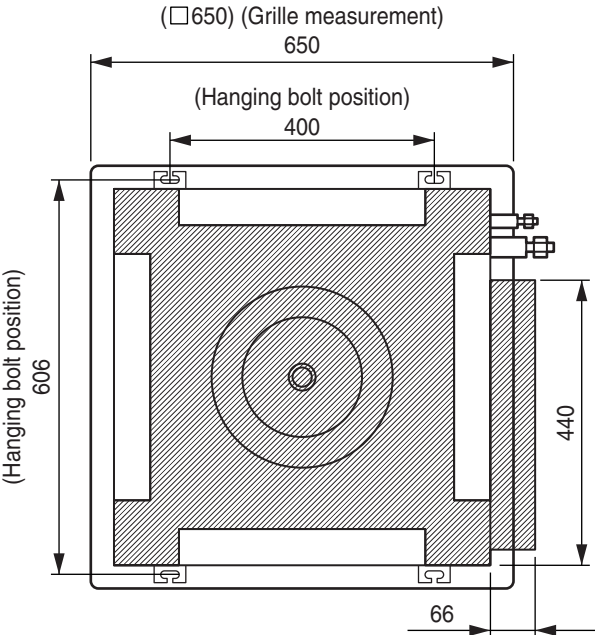
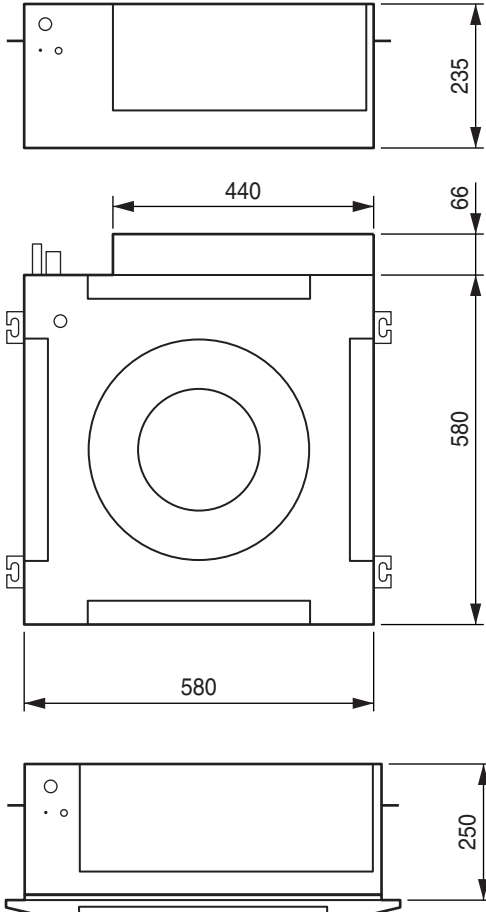
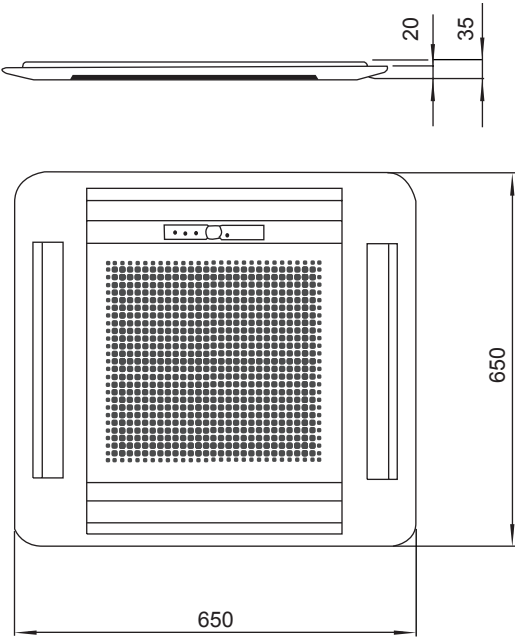

OUTDOOR UNIT

Unit : mm

Model : AOY18LMAK2

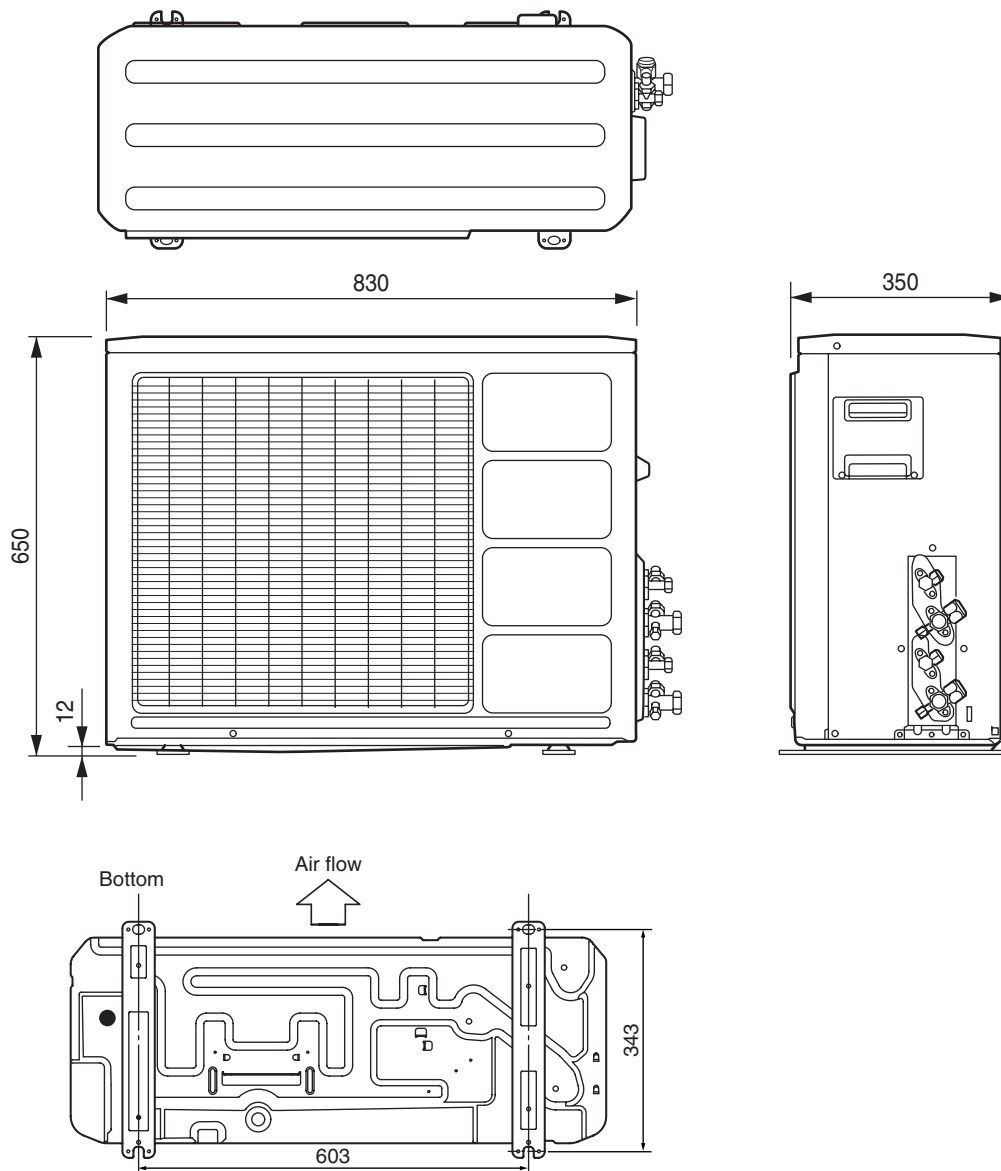

REFRIGERANT SYSTEM DIAGRAM

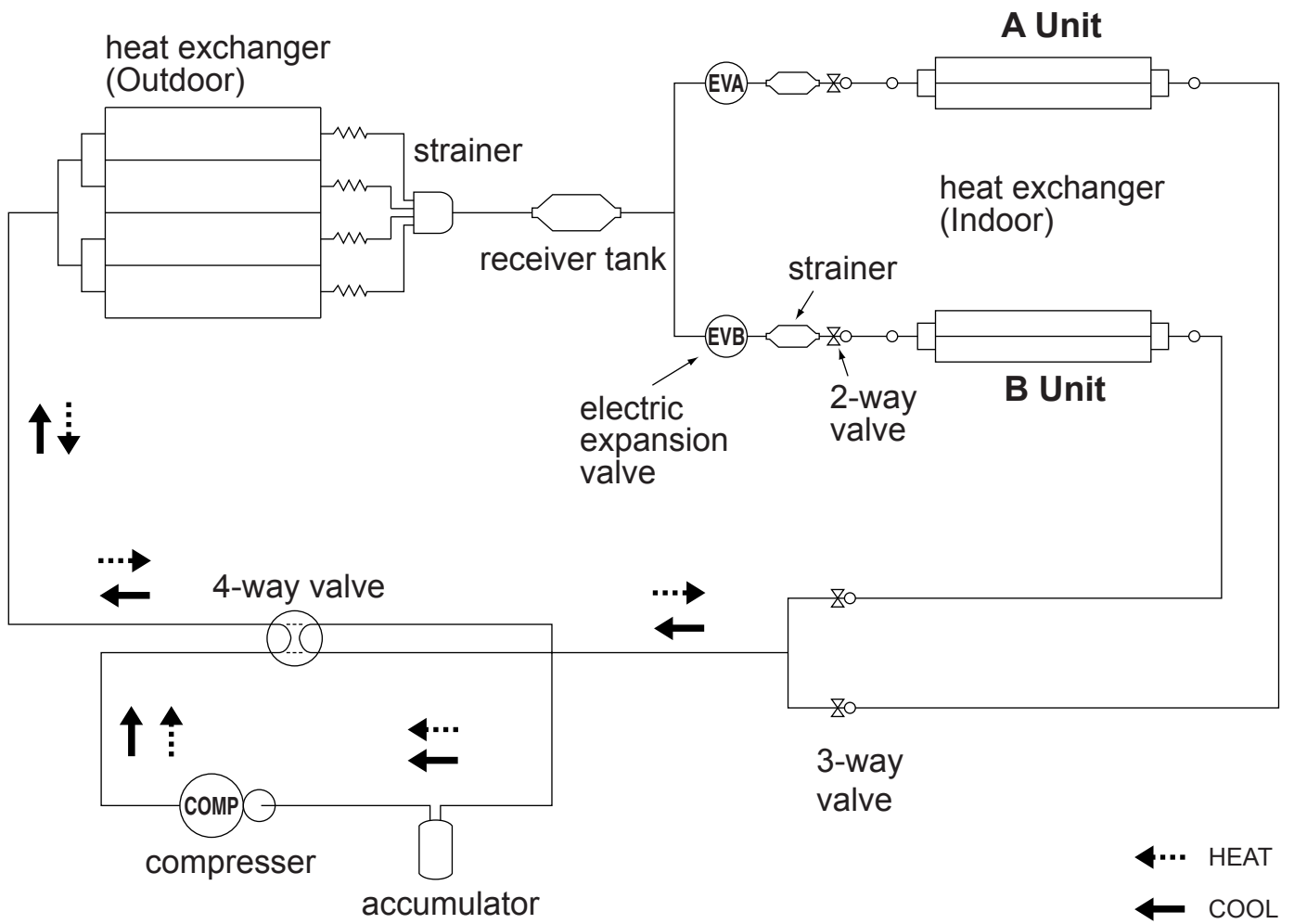

CIRCUIT DIAGRAM

INDOOR UNITS

Models :
AUY12LBAB
AUY14LBAB

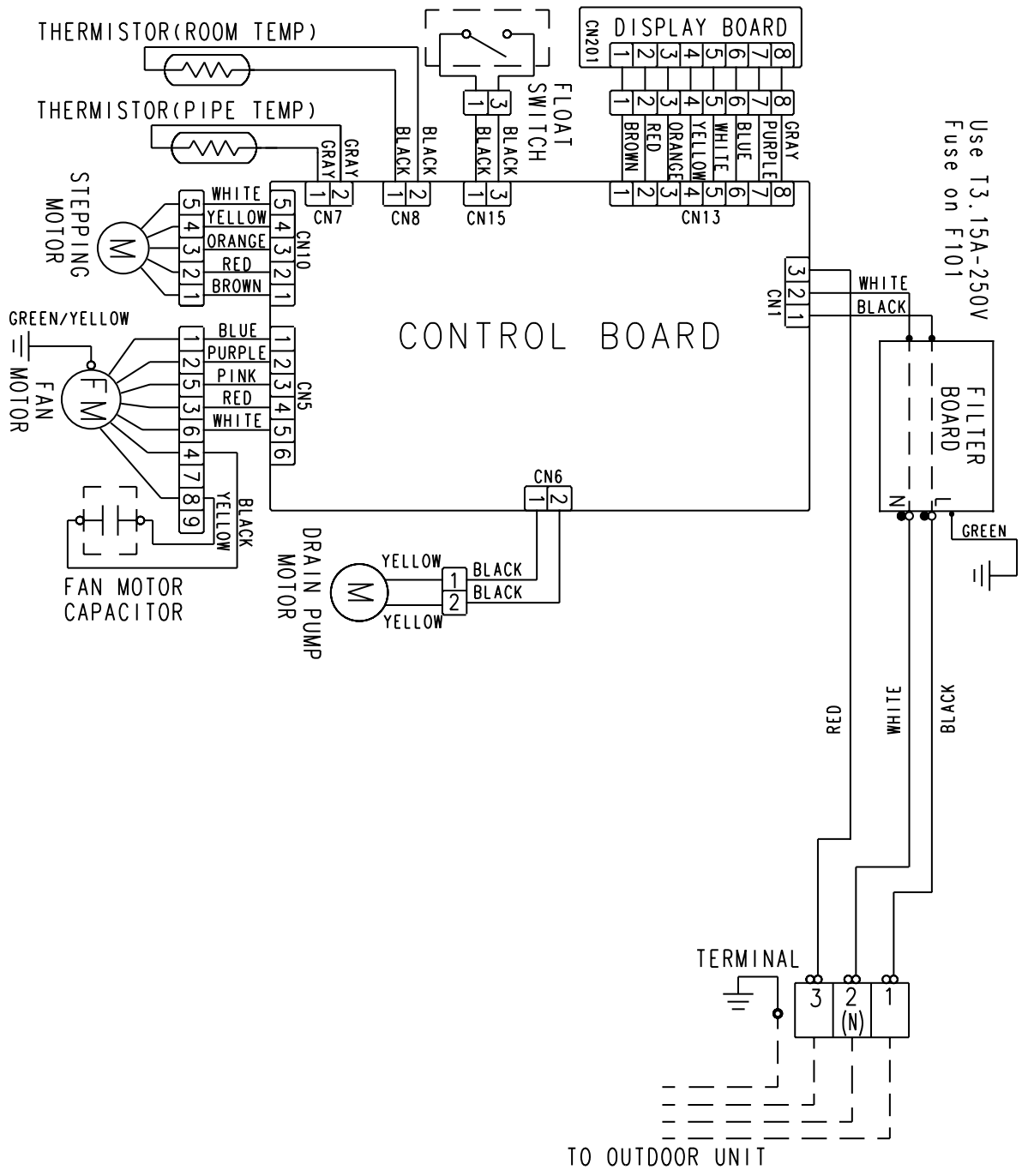

OUTDOOR UNIT

Model : AOY18LMAK2

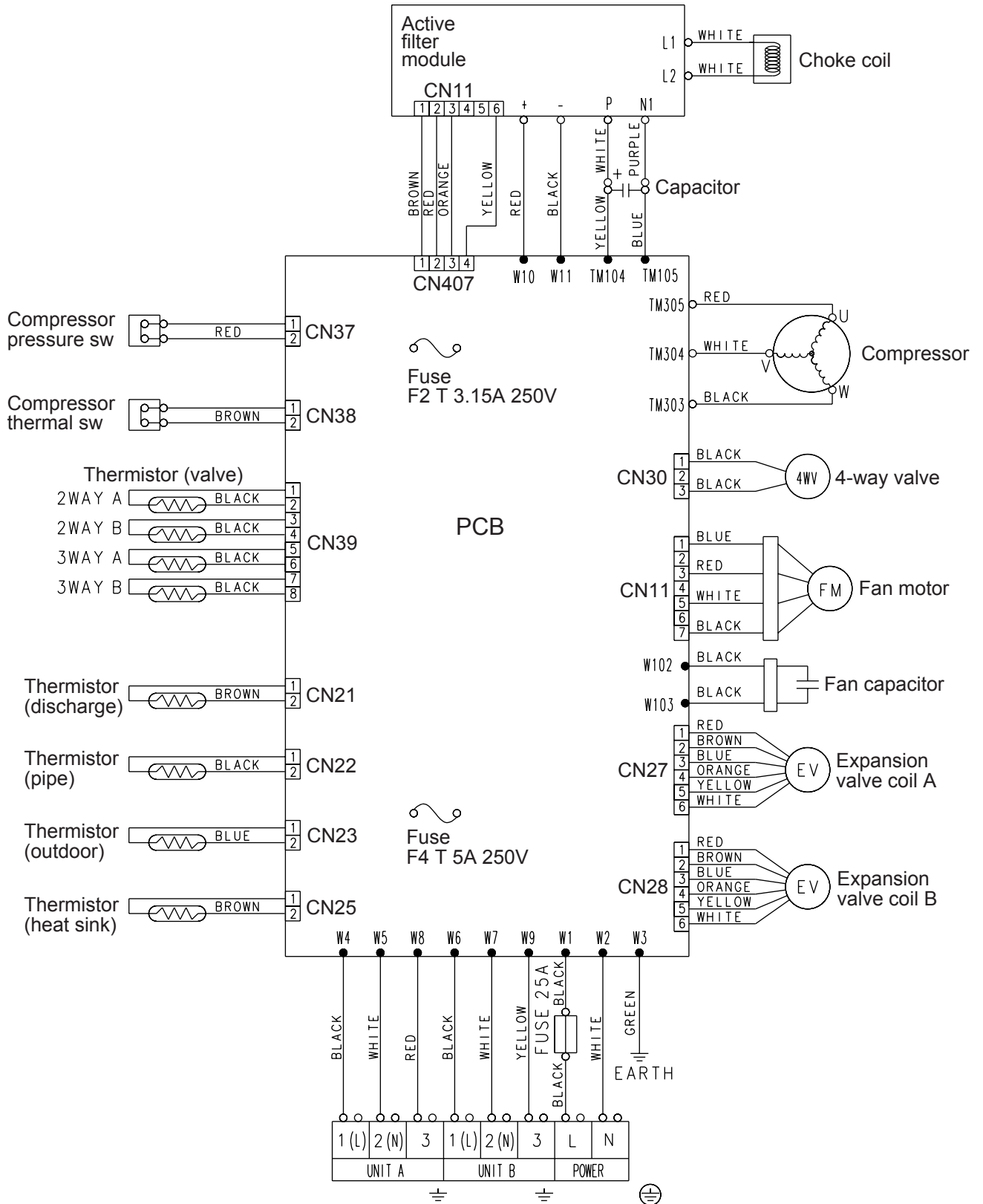

INDOOR PCB CIRCUIT DIAGRAM

CONTROLLER PCB ASSY (MAIN PCB)

AUY12LAB : K01AL-040THSE-C1

AUY14LAB : K01AL-040WHSE-C1

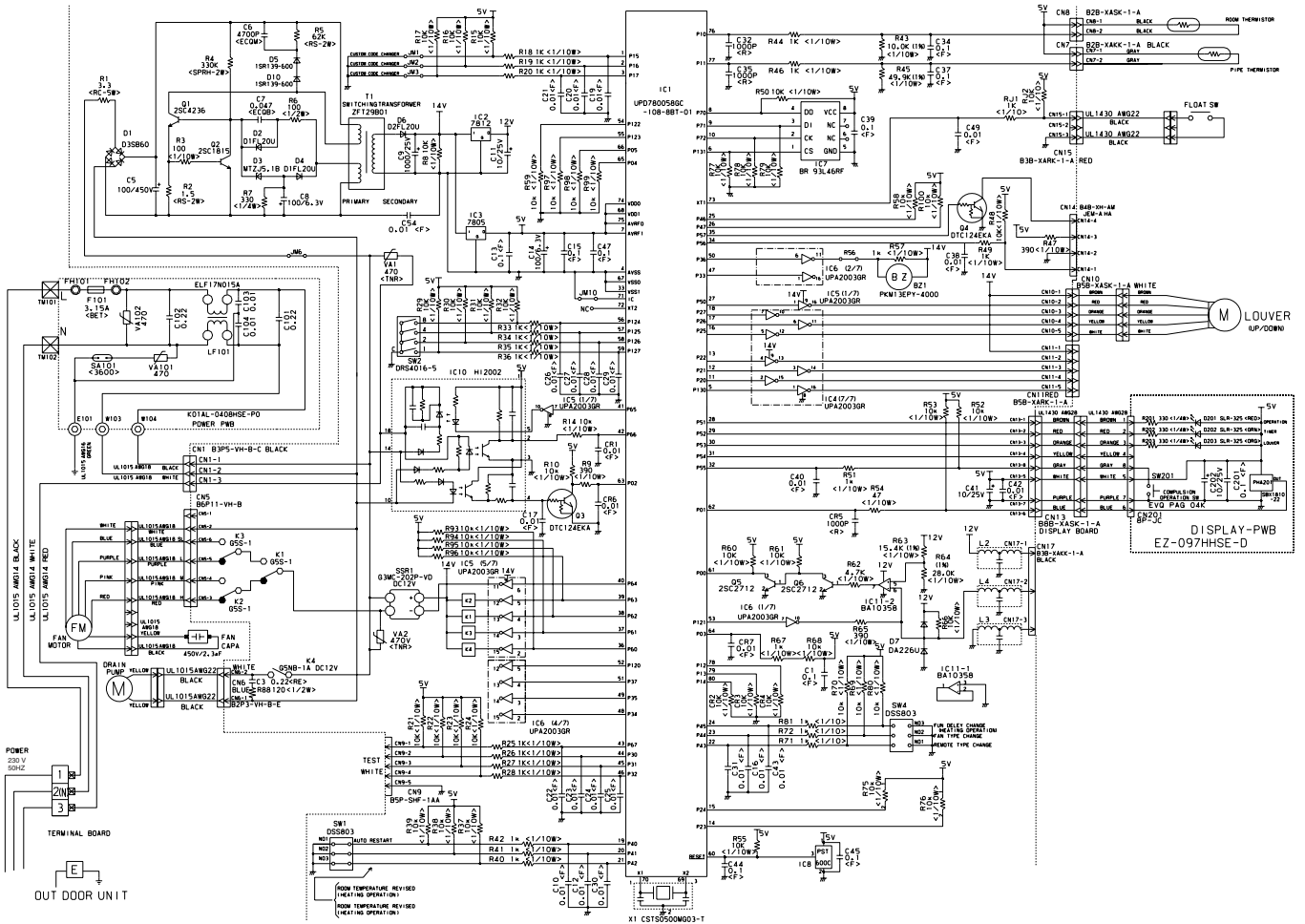

OUTDOOR PCB CIRCUIT DIAGRAM

Model : AOY18LMAK2

CONTROLLER PCB ASSEMBLY (MAIN PCB)
K03AV-0500HUE-C1

CHOKO COIL
L=3MM 30A

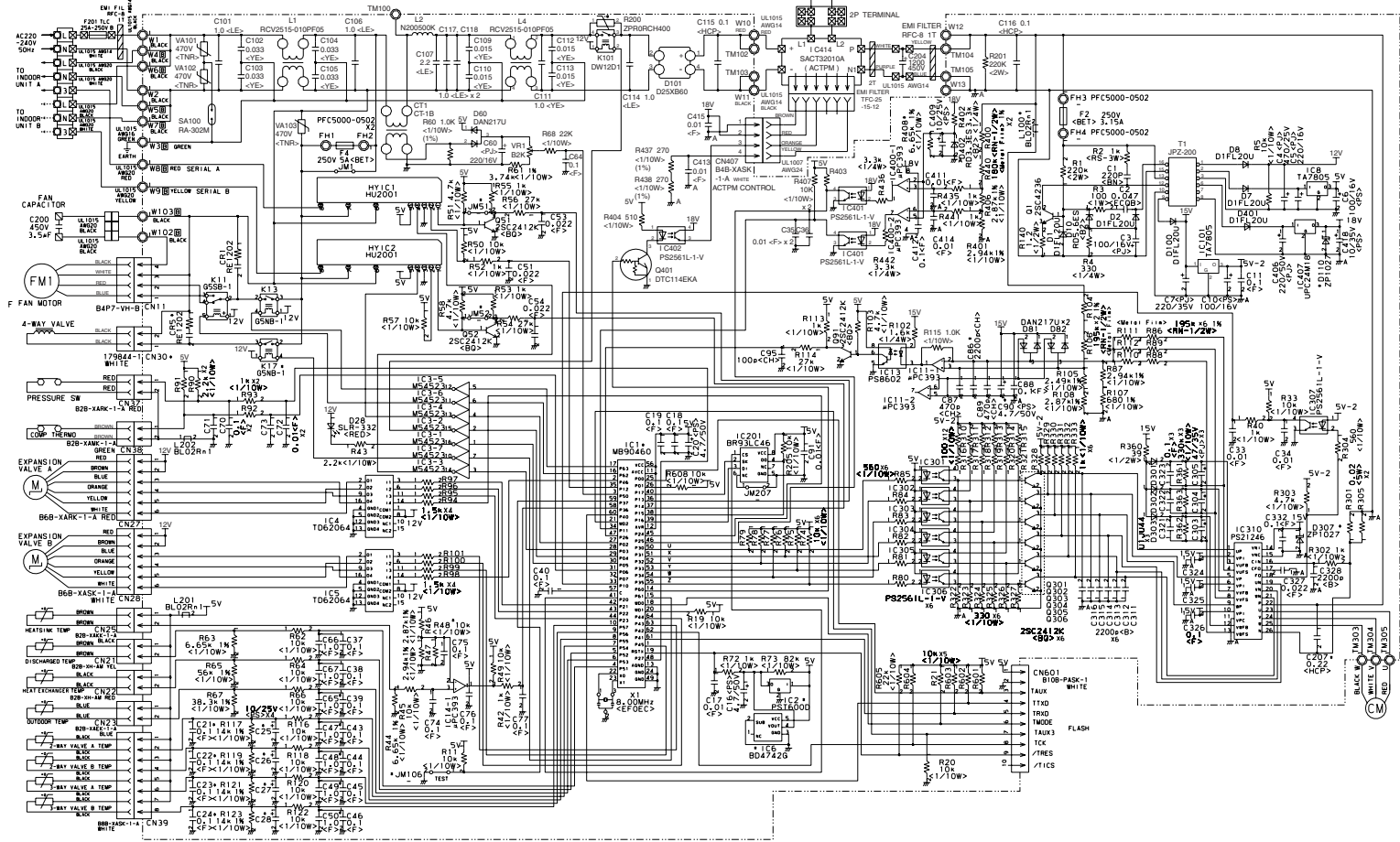

ERROR CONTENTS

Operation can be checked by lighting and flashing of the grille display section OPERATION and TIMER lamps. Perform judgment in accordance with the following.

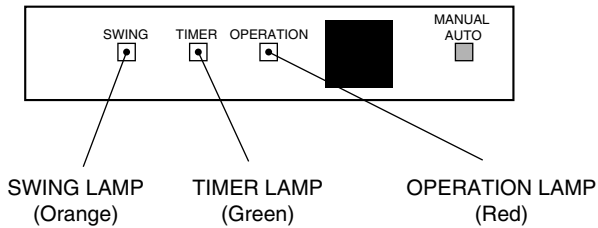

TEST RUNNING

When the air conditioner is run by pressing the remote control unit test run button, the OPERATION and TIMER lamps flash slowly at the same time.

CHECK ITEMS

1. INDOOR UNIT

- (1) Is operation of each button on the remote control unit normal?
- (2) Does each lamp light normally?
- (3) Do not air flow direction louvers operate normally?
- (4) Is the drain normal?
- (5) Is there any abnormal noise and vibration during operation?

INDOOR UNIT

Error display			Error contents
OPERATION lamp	TIMER lamp	SWING lamp	
Blinks	Blinks	Goes off	Indoor unit Model information abnormal (permanent type)
Pulses 4 times	Blinks	Goes off	Indoor unit Drain abnormal (permanent type)
Pulses 6 times	Blinks	Goes off	Indoor fan abnormal
Pulses 2 times	Blinks	Goes off	Room air temperature thermistor open circuit
		Blinks	Room air temperature thermistor short circuit
Pulses 3 times	Blinks	Goes off	Indoor unit Piping thermistor open circuit
		Blinks	Indoor unit Piping thermistor short circuit
Pulses 5 times	Blinks	Goes off	Outdoor unit circuit board error or miswiring between outdoor unit and indoor unit
Blinks	Pulses 5 times	Goes off	Outdoor unit discharge temperature sensor error
Blinks	Pulses 3 times	Goes off	Outdoor unit piping sensor error
Blinks	Pulses 4 times	Goes off	Outdoor unit outdoor unit temperature sensor error

DISASSEMBLY ILLUSTRATION

INDOOR UNITS

Models : AUY12LBAB, AUY14LBAB

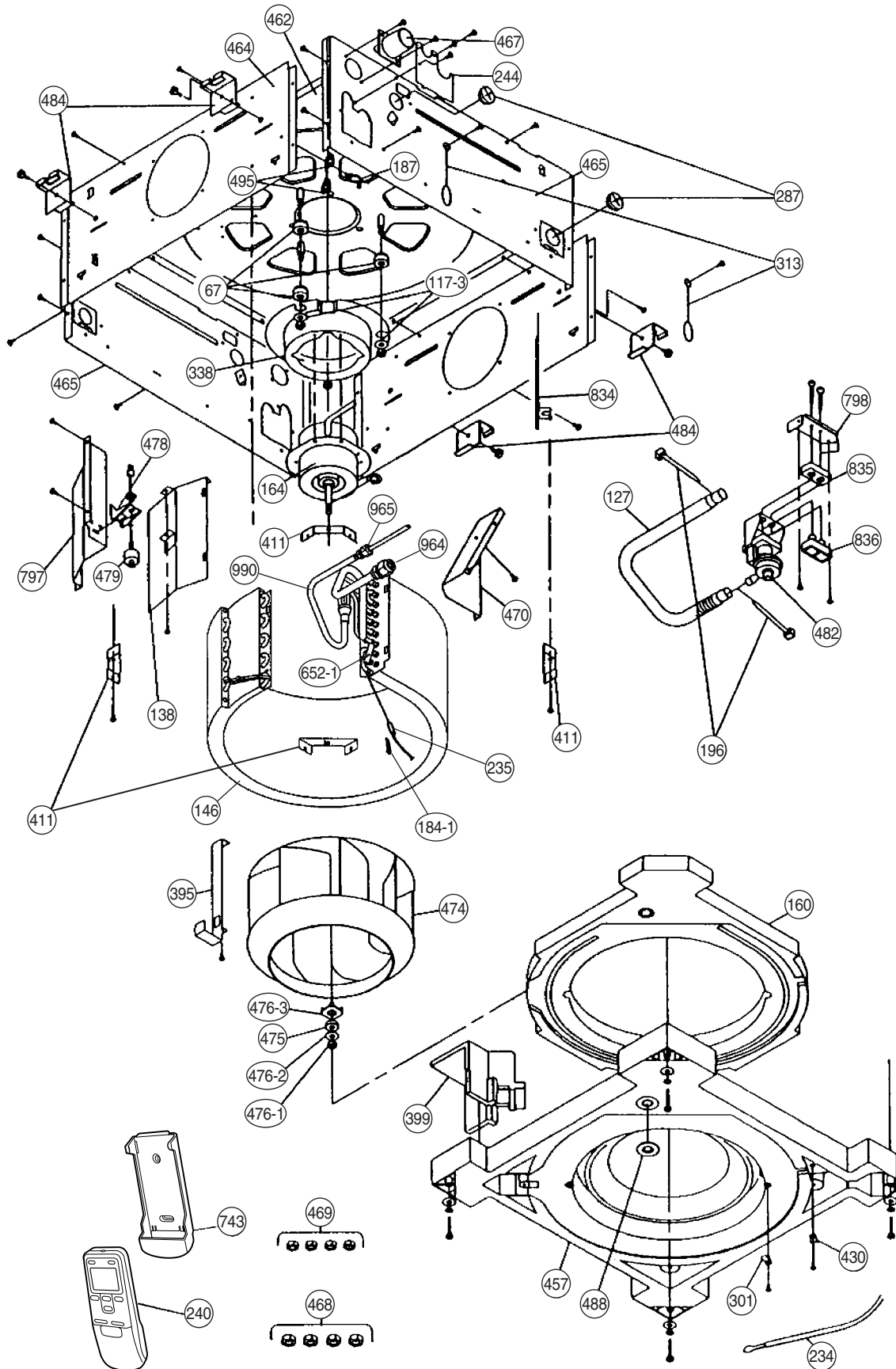

**Models : AUY12LBAB
AUY14LBAB**

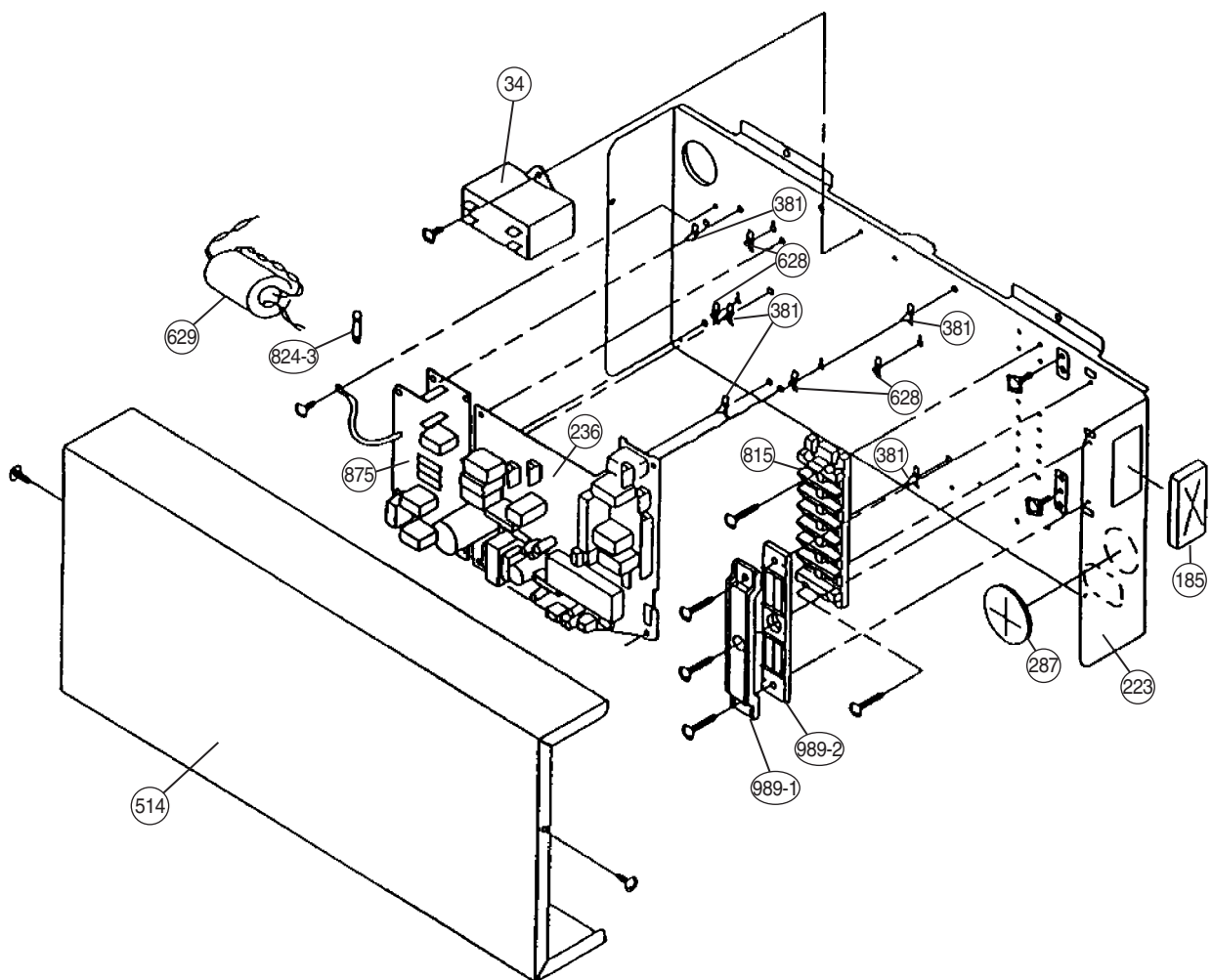

Model : UTG-UDYD-W

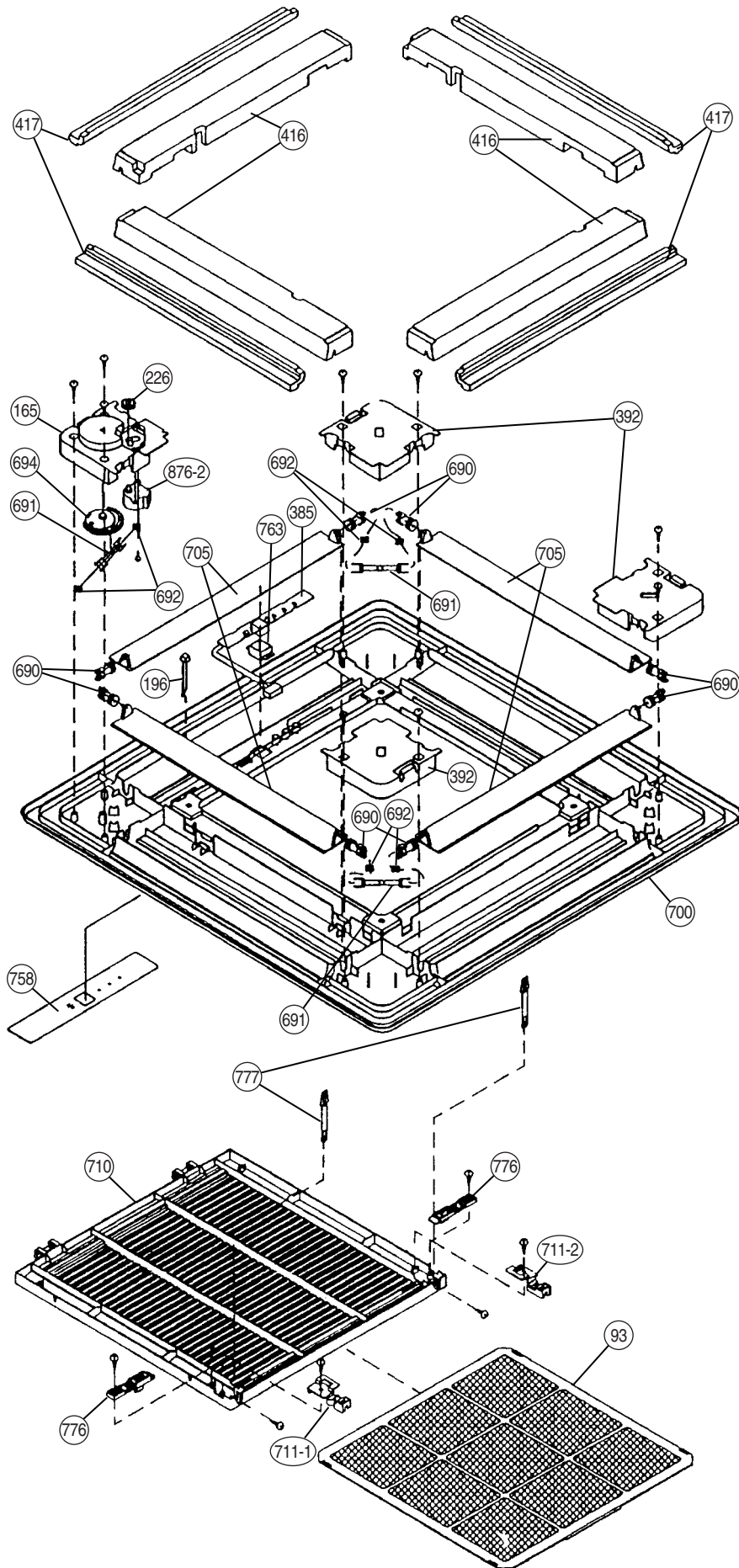

Model : AOY18LMAK2

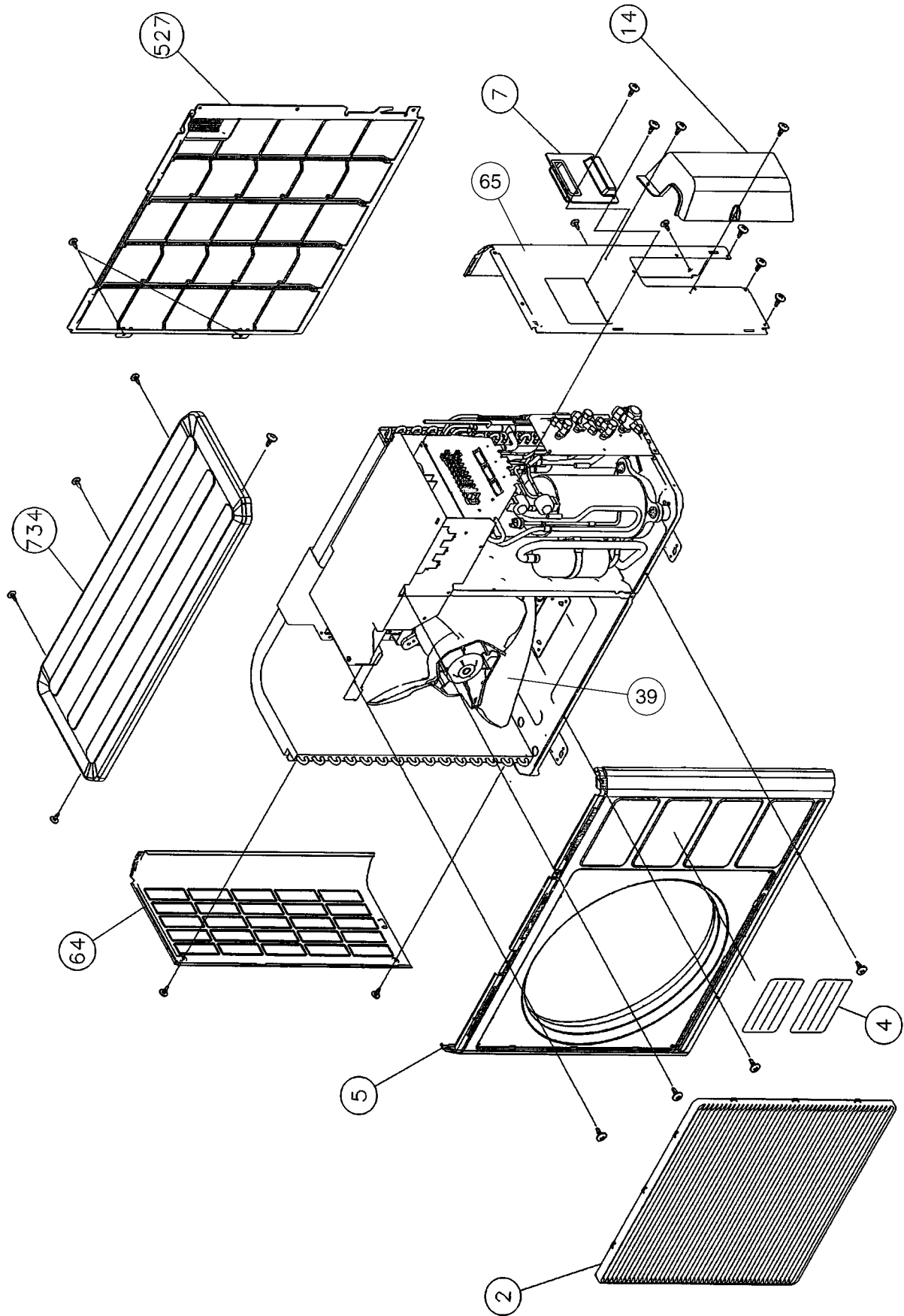

Model : AOY18LMAK2

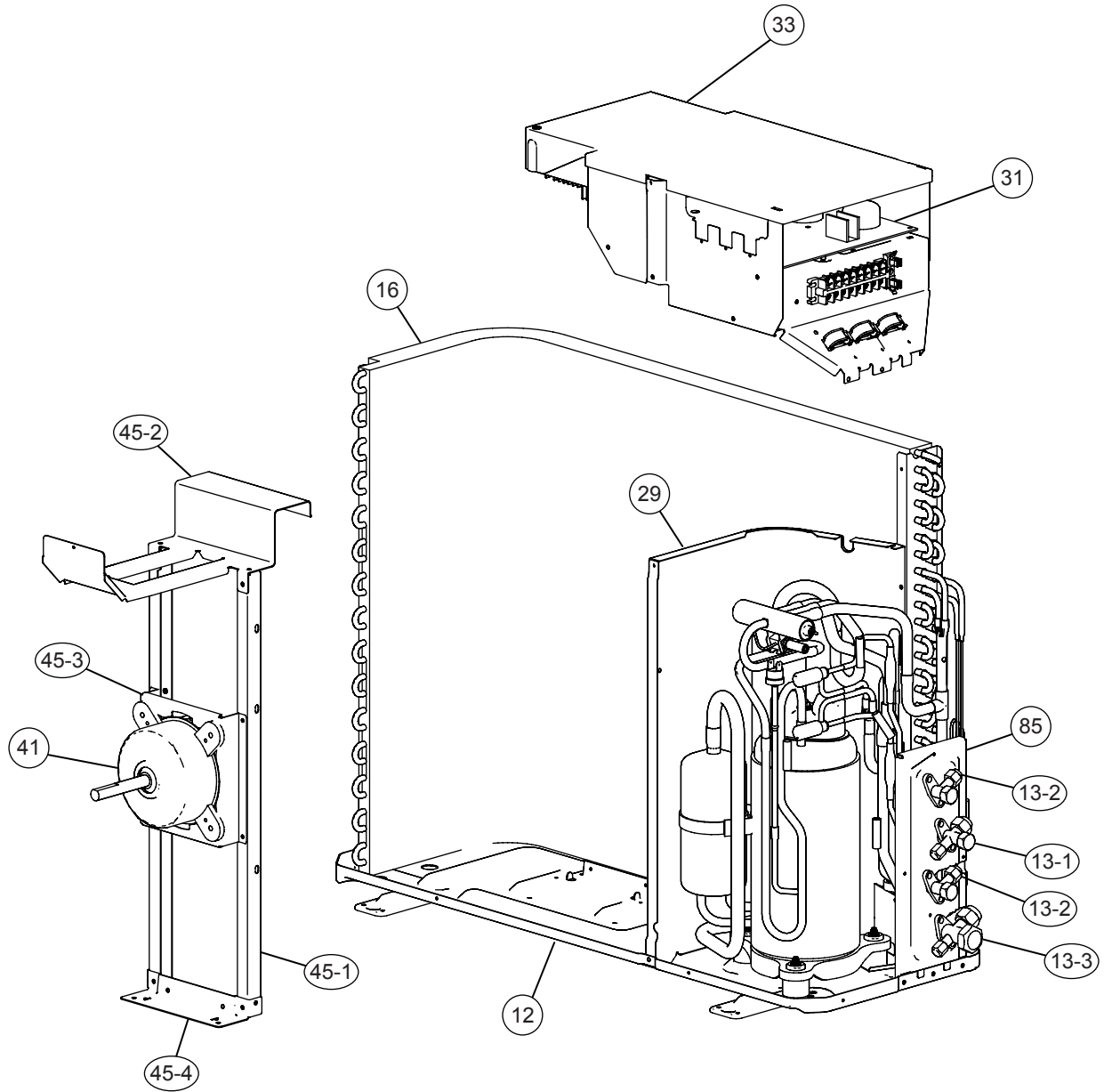

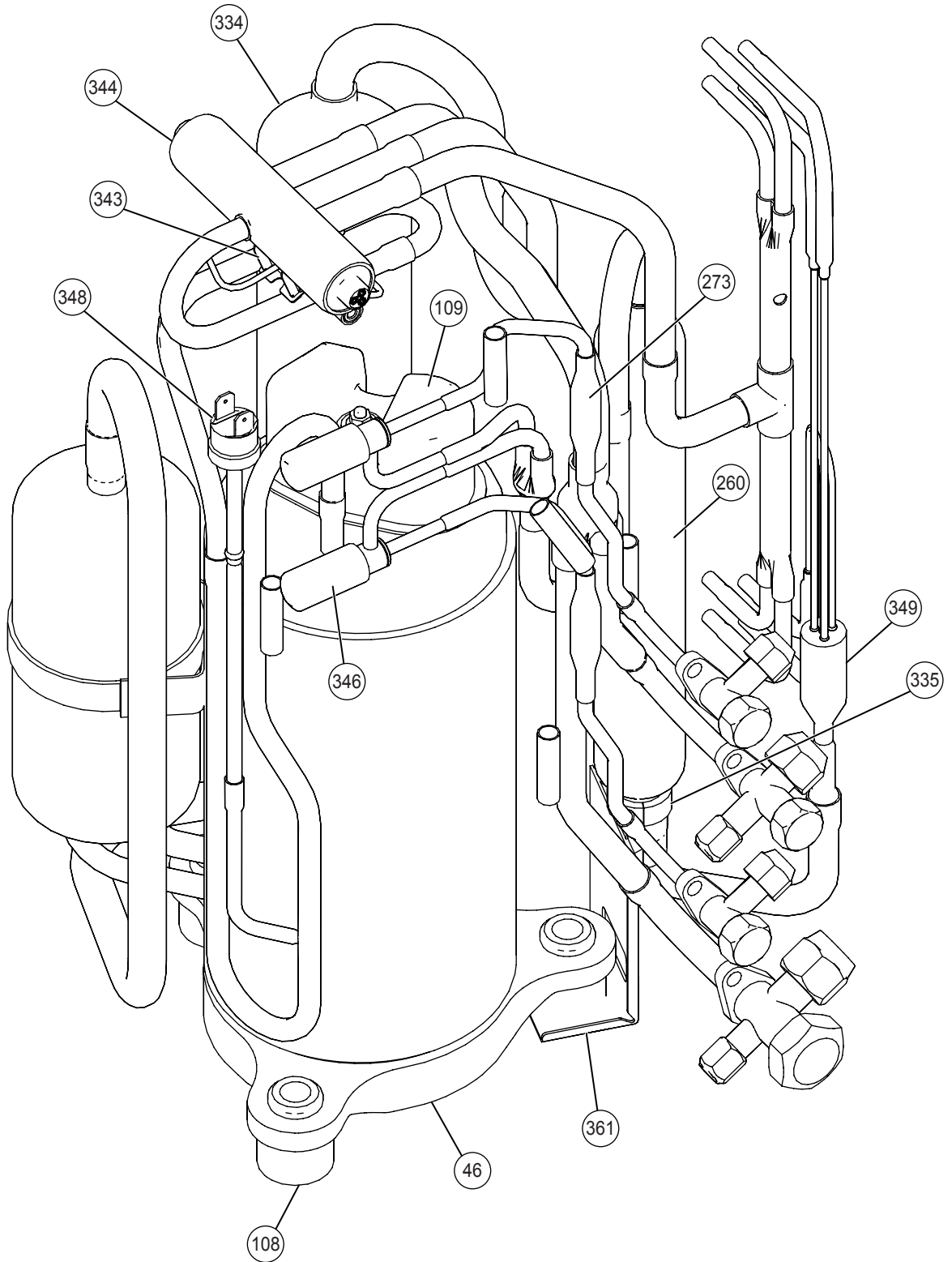

Model : AOY18LMAK2

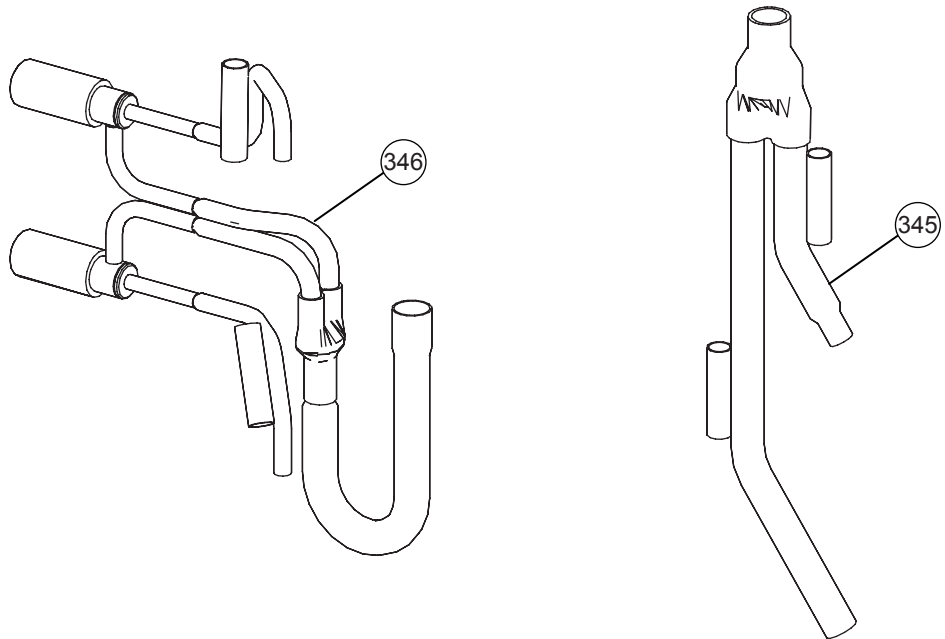
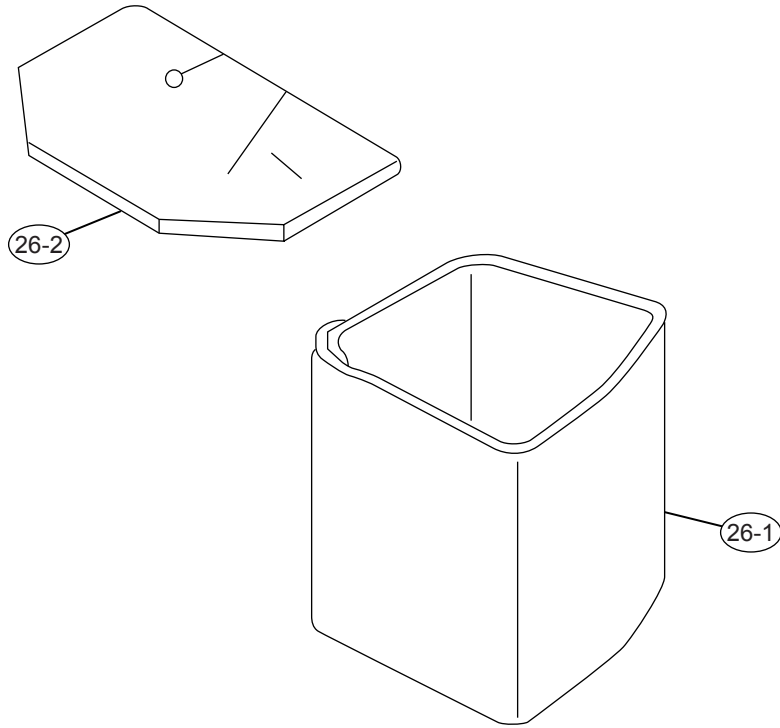

PARTS LIST

INDOOR UNIT

Ref. No.	Description	Part No.		Ord. Q'ty
		AUY12LBAB	AUY14LBAB	
34	Capacitor (Fan Motor)	9704305046	9704305046	
67	Rubber	9361279001	9361279001	
117-3	Special Washer M6	313306391007	313306391007	
127	Drain Hose	9359659013	9359659013	
138	Separate Wall-A	9359647003	9359647003	
146	Evaporator Assy-IN	9373214014	9373214014	
160	Drain Pan	9359651000	9359651000	
164	Fan Motor Assy-IN	9601040064	9601040064	
184-1	Thermo. Spring-A	313728262708	313728262708	
185	Rubber Bushing	313005066051	313005066051	
187	Clamp No. 1219	313361271706	313361271706	
196	Clamp SKB-150	313035356905	313035356905	
223	Control Box	9359661016	9359661016	
234	Thermistor Assy-Room	9703299032	9703299032	
235	Thermistor Assy-Pipe	9703297014	9703297014	
236	Controller PCB Assy	9704557933	9704557940	
240	Remote Control Unit	9371190037	9371190037	
244	Pipe Cover	9359646006	9359646006	
287	Cap (Power)	9352173011	9352173011	
301	Clamp NK-2N	313985355201	313985355201	
313	Hooking Wire	9359983002	9359983002	
338	Motor Fixture	9359656005	9359656005	
381	Locking Spacer	313209391506	313209391506	
395	Supporter (Eva.)	9373179016	9373179016	
399	Air Duct	9359660002	9359660002	
411	Supporter-A	9359655008	9359655008	
430	Clamp NK-7N	313095365602	313095365602	
457	Drain Pan Support	9359652007	9359652007	
462	Top Cover Plate	9359642015	9359642015	
464	Body-A	9359643005	9359643005	
465	Body-B	9359645009	9359645009	
467	Drain Port	313005415658	313005415658	
468	Special Nut-A (Large)	313005446653	313005446653	
469	Special Nut-B (Small)	313005446759	313005446759	
470	Separate Wall-B	9359648000	9359648000	
474	Turbo Fan	9359658009	9359658009	
475	Turbo Fan Rubber	9366013006	9366013006	
476-1	Special Nut M8	313005360755	313005360755	
476-2	Special Washer	301801185049	301801185049	
476-3	Special Washer	9359954002	9359954002	
478	Sensor M. Bracket	9359654001	9359654001	
479	Float Switch	313005416154	313005416154	
482	Pump Unit	9359974000	9359974000	
484	Hanger Metal	9359644002	9359644002	
488	Drain Pan Plug	9359653004	9359653004	
495	Clamp No. 2U46	9352715006	9352715006	
514	Control Box Cover	9359662006	9359662006	
628	Locking Spacer-B	313005446558	313005446558	
629	EMI Filter	0400197119	0400197119	
652-1	Therm. Holder Pipe	313806262805	313806262805	
743	Remote Control Holder Case	9305642014	9305642014	
797	Separate Wall-C	9359649007	9359649007	
798	Pump Hook Bracket	9359650003	9359650003	
815	Terminal-3P	9900203016	9900203016	
824-3	Fuse	0600222512	0600222512	
834	Wire Cover	9359878001	9359878001	
835	Cushion-A (For Pump)	9352211003	9352211003	
836	Cushion-B (For Pump)	9356084016	9356084016	
875	Filter PCB Assy	9704561213	9704561213	
964	Flare Nut-1/2	----	9373267010	
965	Flare Nut-B	9351062019	9351062019	
989-1	Cord Clamp-A	9359822011	9359822011	
989-2	Cord Clamp-B	9359823018	9359823018	
990	Distributor Assy	9373034049	9373034049	

GRILLE ASSY (UTG-UDYD-W)

Ref. No.	Description	Part No.	Ord. Q'ty
93	Filter	9359632009	
165	Motor Cover	9359623014	
196	Clamp SKB-150	313035356905	
226	Motor Gear	9359629009	
385	Indicator PCB Assy	9702224011	
392	Cover-A	9359622017	
416	Insulation (Panel)-A	9359620006	
417	Insulation (Panel)-B	9359621003	
690	Joint-A	9359626008	
691	Joint-B	9359627005	
692	Joint Shaft	9359625001	
694	Cam Gear	9359628002	
700	Panel	9359619017	
705	Louver	9359624011	
710	Intake Grille	9370126006	
711-1	Filter Clamp-A	9359634003	
711-2	Filter Clamp-B	9359635000	
758	Decoration Plate-A (UTG-UDYD-W)	9360039019	
763	Receiver Cover	9359630005	
776	Grille Stopper	9359633013	
777	Grille Hook	9359761006	
876-2	Step Motor-V	9360307019	

OUTDOOR UNIT







Ref. No.	Description	Part No.	Ord. Q'ty	Ref. No.	Description	Part No.	Ord. Q'ty
		AOY18LMAK2				AOY18LMAK2	
2	Fan Guard	9371187013		335	Accumulator Holder Rubber	9354022010	
4	Emblem	9351355005		343	Solenoid	9900165079	
5	Front Panel	9371924014		344	4-Way Valve	9900163013	
7	Connecteur Cover (Cabinet)	9366398004		345	Joint Pipe (3Way) Assy	9373729129	
12	Base Assy	9371920078		346	Expansion Valve Assy	9373729068	
13-1	3-Way Valve	9372205044		348	Pressure Switch Assy	9373729044	
13-2	2-Way Valve	9372204054		349	Capirally Assy	9373729211	
13-3	3-Way Valve	9372205051		361	Accum Support Assy	9372252017	
14	Valve Cover	9372796016		527	Protective Net	9371934013	
16	Condenser Assy	9372181096		734	Top Panel	9372304013	
26-1	Compressor Cover A	9373730019		---	Gasket (Comp)	9373266013	
26-2	Compressor Cover B	9373730026		---	Washer (Rubber) (Comp)	9358078006	
29	Separate Wall	9372795019		---	Compressor pressure switch	9900186012	
31	Controller PCB Assy	9705285057		---	Compressor thermal switch	9373263012	
33	Control Cover	9372792018		---	Thermistor Valve	9900194017	
39	Propeller Fan Assy	9366378013		---	Thermistor discharge	9704219039	
41	Motor Induct	9601671046		---	Heat exchanger thermistor	9704220059	
45-1	Motor Bracket	9371929019		---	Thermistor outdoor	9703516047	
45-2	Motor Bracket-Top	9371931012		---	Thermistor heat sink	9900195014	
45-3	Motor Bracket-Center	9371930015		---	Special Nut M8 (Comp)	9355091008	
45-4	Motor Bracket-Bottom	9371932019		---	Condenser Sub Assy	9372313121	
46	Compressor Assy	9373262015		---	Thermister Holder Pipe	313714262805	
64	Side Panel L	9371926018		---	Capacitor, Plastic	9704305077	
65	Side Panel R	9371927015		---	Clip (Cable)	9352715006	
85	Valve Plate	9371928036		---	Br Sheet	9363708042	
108	Rubber Seat (Comp)	9358080009		---	Relay	9900117016	
109	Terminal Cover (Comp)	9373264019					
260	Receiver Tank Assy	9373426011					
273	Strainer Assy	9366602019					
334	Accumulator	9368391003					

Inverter Assy

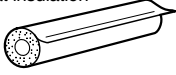

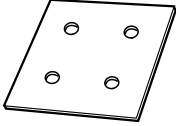
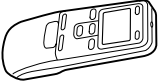
Ref. No.	Description	Part No.	Ord. Q'ty
31	Controller PCB Assy	9705285057	
---	ACTPM	9703457012	
---	Capacitor, Elec	9705387010	
---	Capacitor, Plastic	9704305077	
---	Fuse	0600086039	
---	Terminal 8P	9900203047	
---	Fuse Holder	0501454012	
---	Terminal 2P	9701971015	

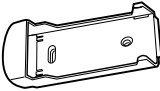
STANDARD ACCESSORIES

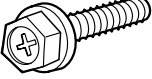

INDOOR UNIT ACCESSORIES

Name and Shape	Application	Part No.
Coupler heat insulation 	For indoor side pipe joint	9350716029
		9352766015
Special nut A (large flange) 	For installing indoor unit	313005446653
Special nut B (small flange) 	For installing indoor unit	313005446759
Template 	For ceiling hole cutting	9360256003
Remote control unit 	Use for air conditioner operation	9371190037
Battery (penlight) 	For remote control unit	0600185534
Remote control unit holder 	For mounting the remote control unit	9305642014
Tapping screw (φ3 x 12) 	For remote control unit holder installation	301141533125

GRILLE ASSY ACCESSORIES

Name and Shape	Application	Part No.
Bolt 	For opening the refrigerant valve on the outdoor unit	0700139116
Washer 	For mounting grille	301801155020
Blower cover insulation 	For discharged air	9360047007

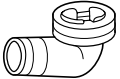
OUTDOOR UNIT ACCESSORIES

Name and Shape	Part No.
Drain pipe 	9303029015
Drain cap 	313166024302
Adapter D (1/2" → 3/8") 12.7mm → 9.52mm 	9370244007

0507G2882