

**SPLIT TYPE
ROOM AIR CONDITIONER
WALL MOUNTED type**

**SERVICE
MANUAL**



Models

Indoor unit	Outdoor unit
ASYA30LCC	AOYR30LCT

CONTENTS

SPECIFICATIONS	1
DIMENSIONS	2
REFRIGERANT SYSTEM DIAGRAM	4
CIRCUIT DIAGRAM	5
INDOOR PCB CIRCUIT DIAGRAM	6
OUTDOOR PCB CIRCUIT DIAGRAM ...	9
ERROR CONTENTS	14
DISASSEMBLY ILLUSTRATION	15
PARTS LIST	23
STANDARD ACCESSORIES	25

SPECIFICATIONS

TYPE	COOL & HEAT INVERTER
INDOOR UNIT	ASYA30LCC
OUTDOOR UNIT	AOYR30LCT
COOLING CAPACITY	8.00 kW
HEATING CAPACITY	9.00 kW

ELECTRICAL DATA

POWER SOURCE	230 V	
FREQUENCY	50 Hz	
RUNNING CURRENT	COOLING	11.7 A
	HEATING	11.6 A
INPUT WATTS	COOLING	2.66 kW
	HEATING	2.64 kW
E.E.R.	COOLING	3.01 kW/kW
COP	HEATING	3.41 kW/kW
MOISTURE REMOVAL	3.4 L/hr	
AIR CIRCULATION-High	1,100 m ³ /hr	

COMPRESSOR

TYPE	Hermetic type, 4 pole, 3 phase, DC inverter motor, Rotary
DISCRIMINATION	5KD 240 x AD21
REFRIGERANT	R410A 2,100 g

FAN MOTOR

POWER SOURCE	230 V	
INDOOR UNIT	HIGH-SPEED	1,330 r.p.m.
	MED-SPEED	1,120 r.p.m.
	LOW-SPEED	940 r.p.m.
	QUIET	830 r.p.m.
OUTDOOR UNIT	Cool	850 r.p.m.
	Heat	900 r.p.m.

DIMENSIONS

INDOOR UNIT	H x W x D	320 x 998 x 228 mm
OUTDOOR UNIT	H x W x D	830 x 900 x 330 mm

WEIGHT

INDOOR UNIT	GROSS / NET	18 kg / 14 kg
OUTDOOR UNIT	GROSS / NET	70 kg / 62 kg

NOISE LEVEL

INDOOR UNIT	Cool 47 dB / Heat 45 dB
OUTDOOR UNIT	Cool 53 dB / Heat 55 dB

REFRIGERANT (R410A)

FULL CHARGE AMOUNT	PIPE LENGTH 20 m	2,100 g
	50 m	3,300 g
ADDITIONAL REFRIGERANT	40 g / m	

OUTLINE AND DIMENSIONS

INDOOR UNIT
Model : ASYA30LCC
(unit : mm)

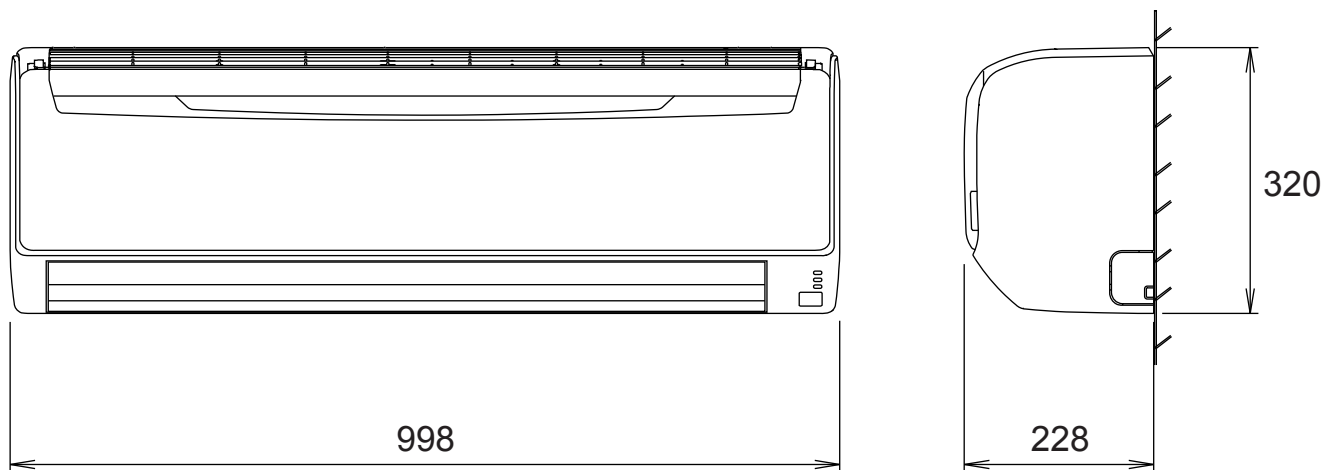

OUTDOOR UNIT
 Model : AOYR30LCT
 (unit : mm)

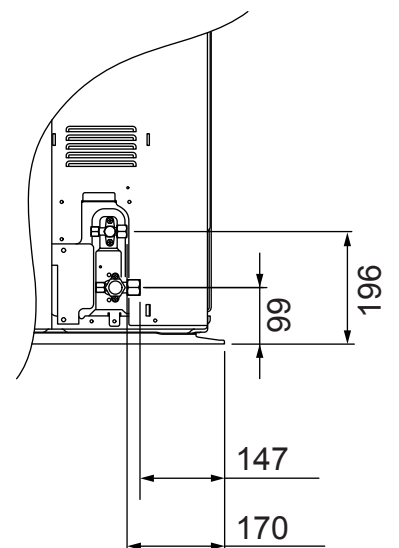
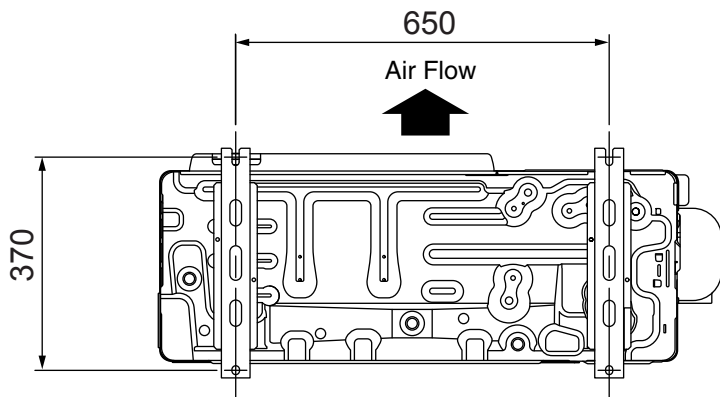
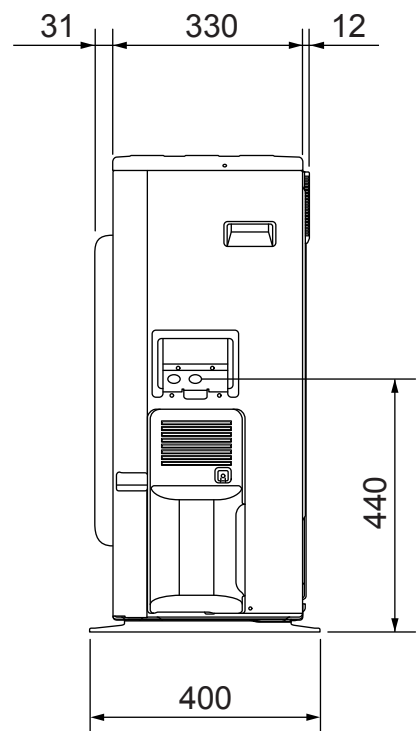
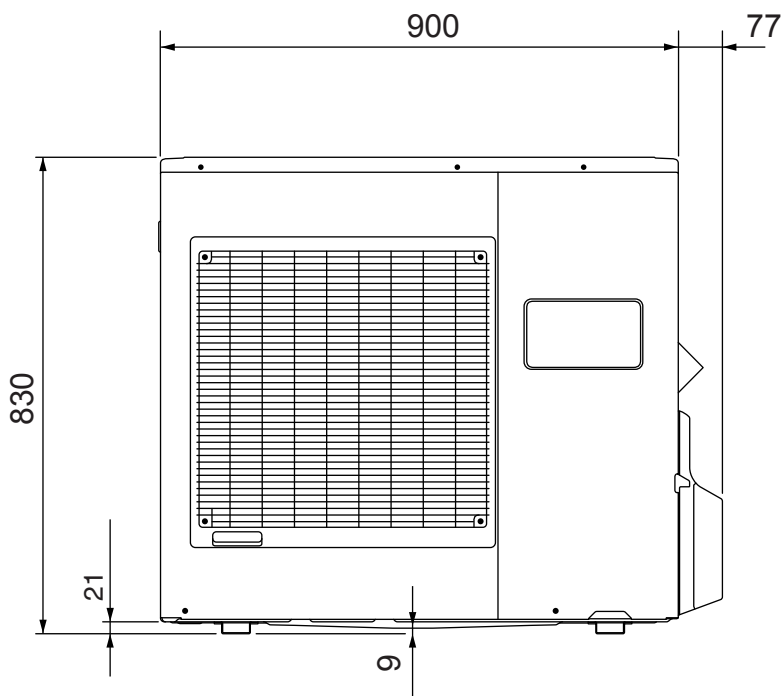
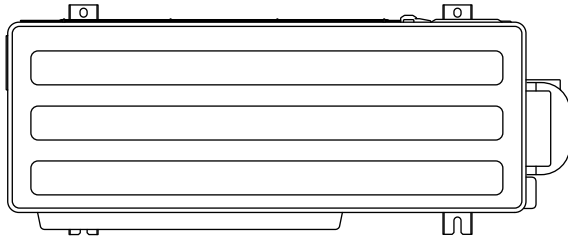

REFRIGERANT SYSTEM DIAGRAM

Models : ASYA30LCC / AOYR30LCT

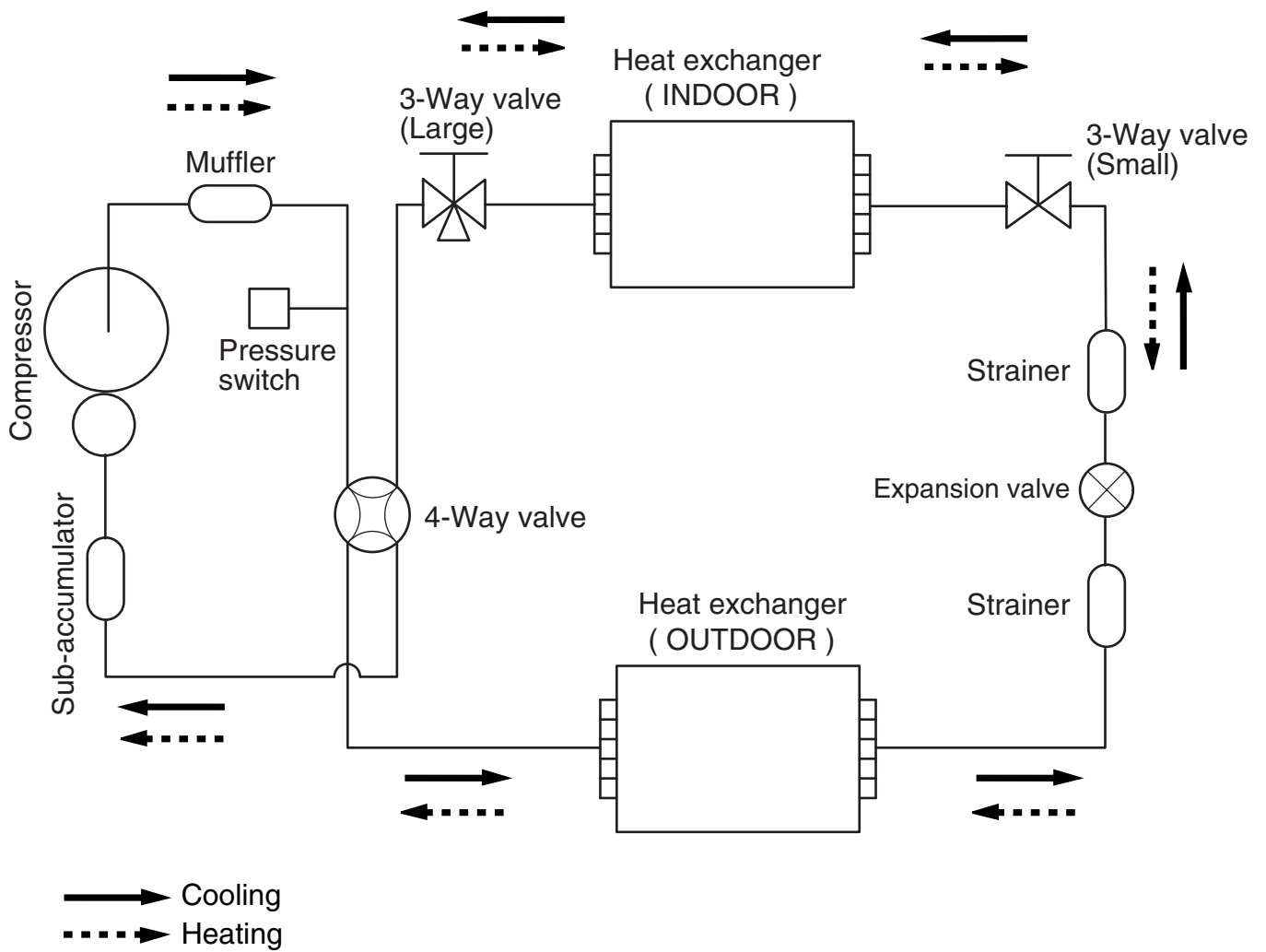

Refrigerant pipe diameter
 Liquid : 3/8" (9.52 mm)
 Gas : 5/8" (15.88 mm)

INDOOR UNIT

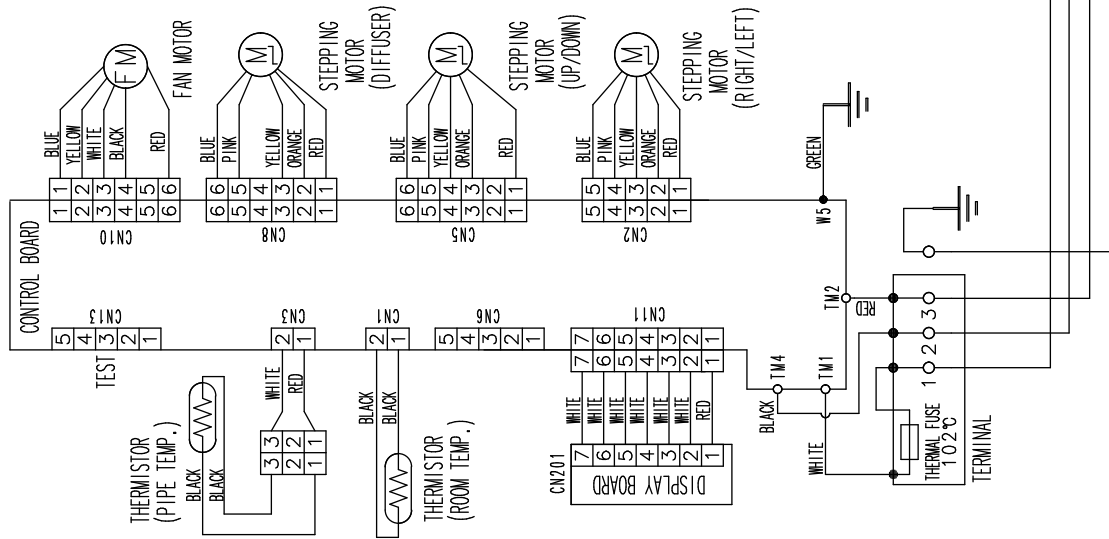

OUTDOOR UNIT

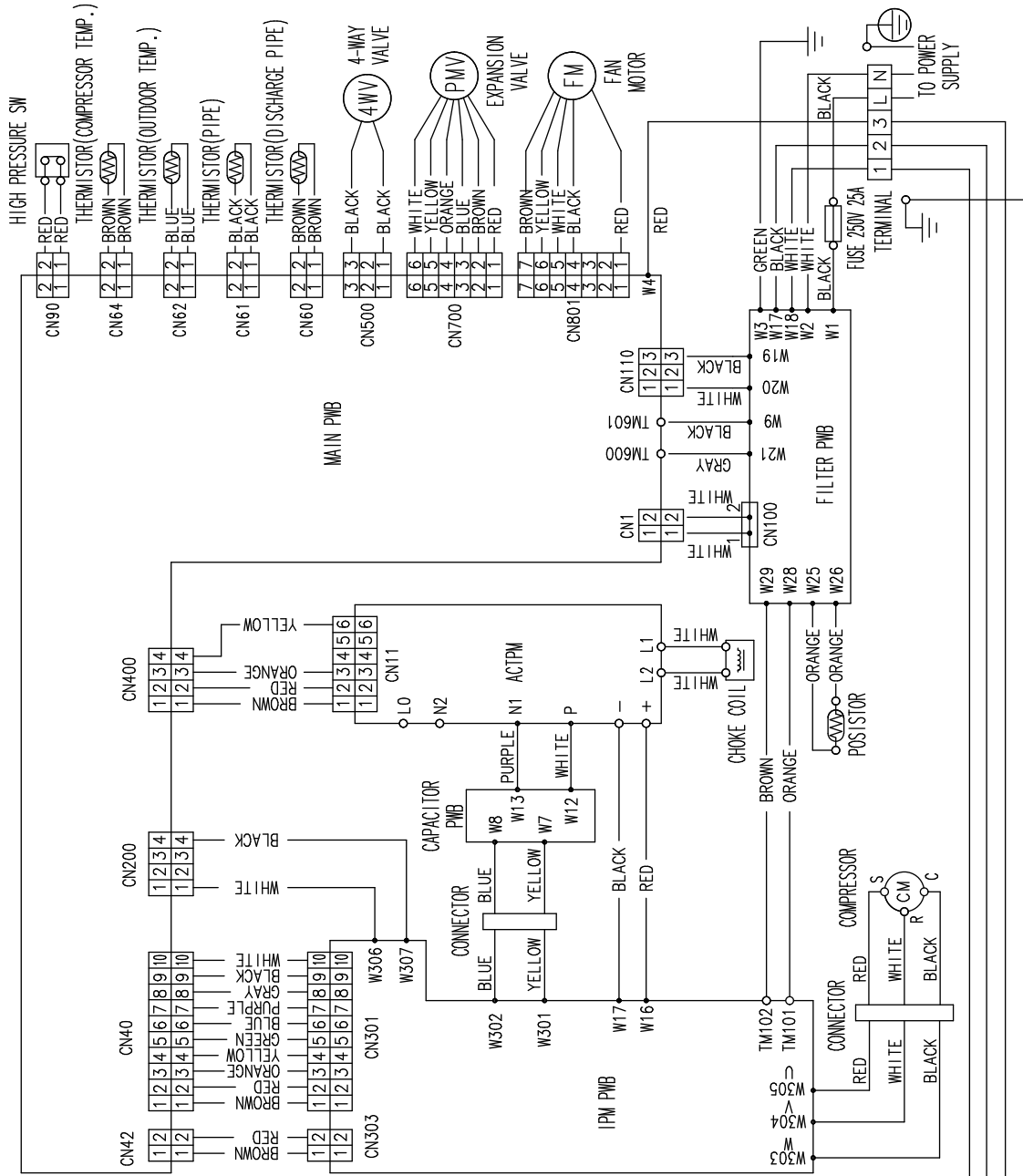

INDOOR PCB CIRCUIT DIAGRAM

Model : ASYA30LCC

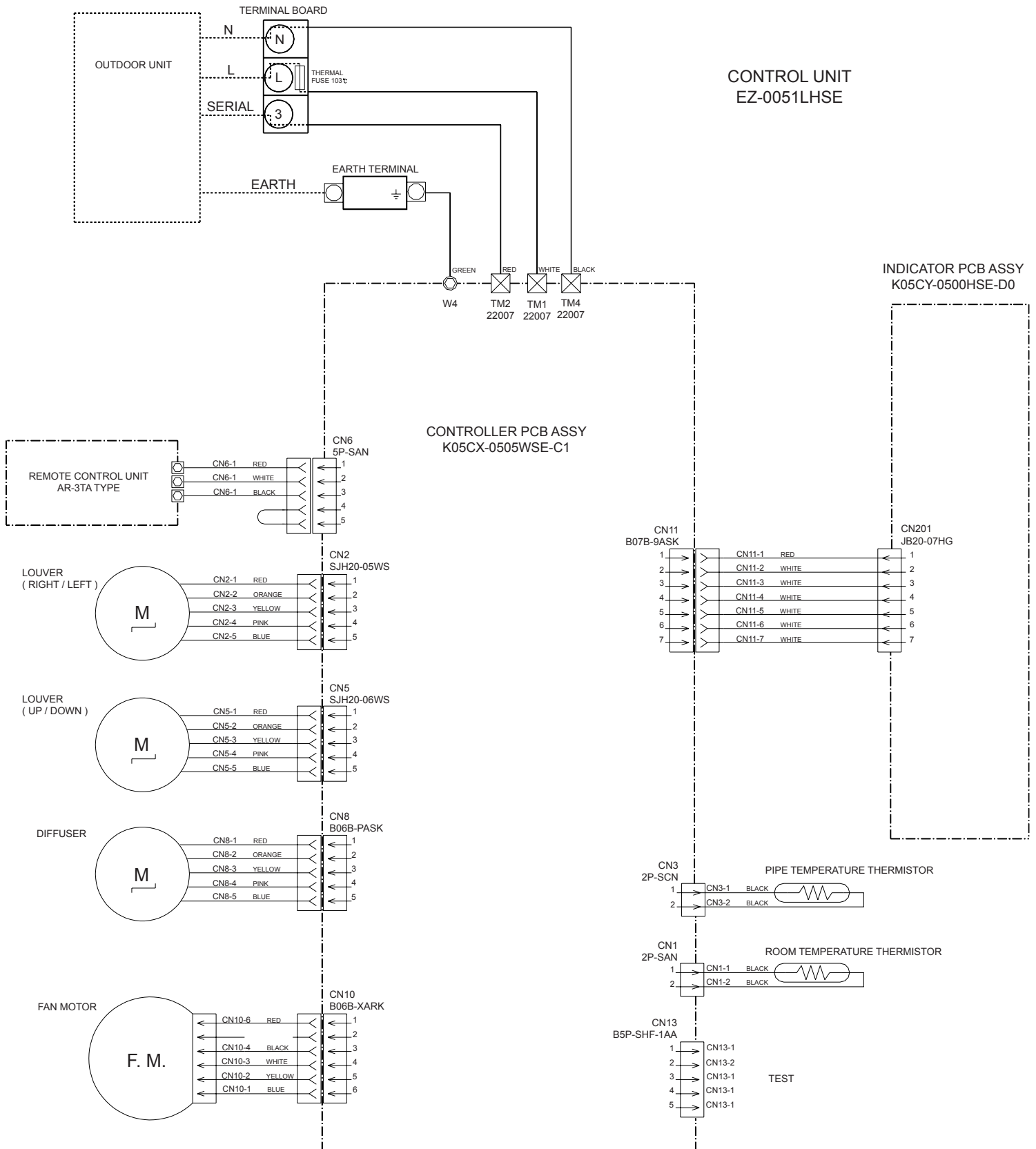

Model : ASYA30LCC

INDICATOR PCB ASSY K05CY-0500HSE-D0

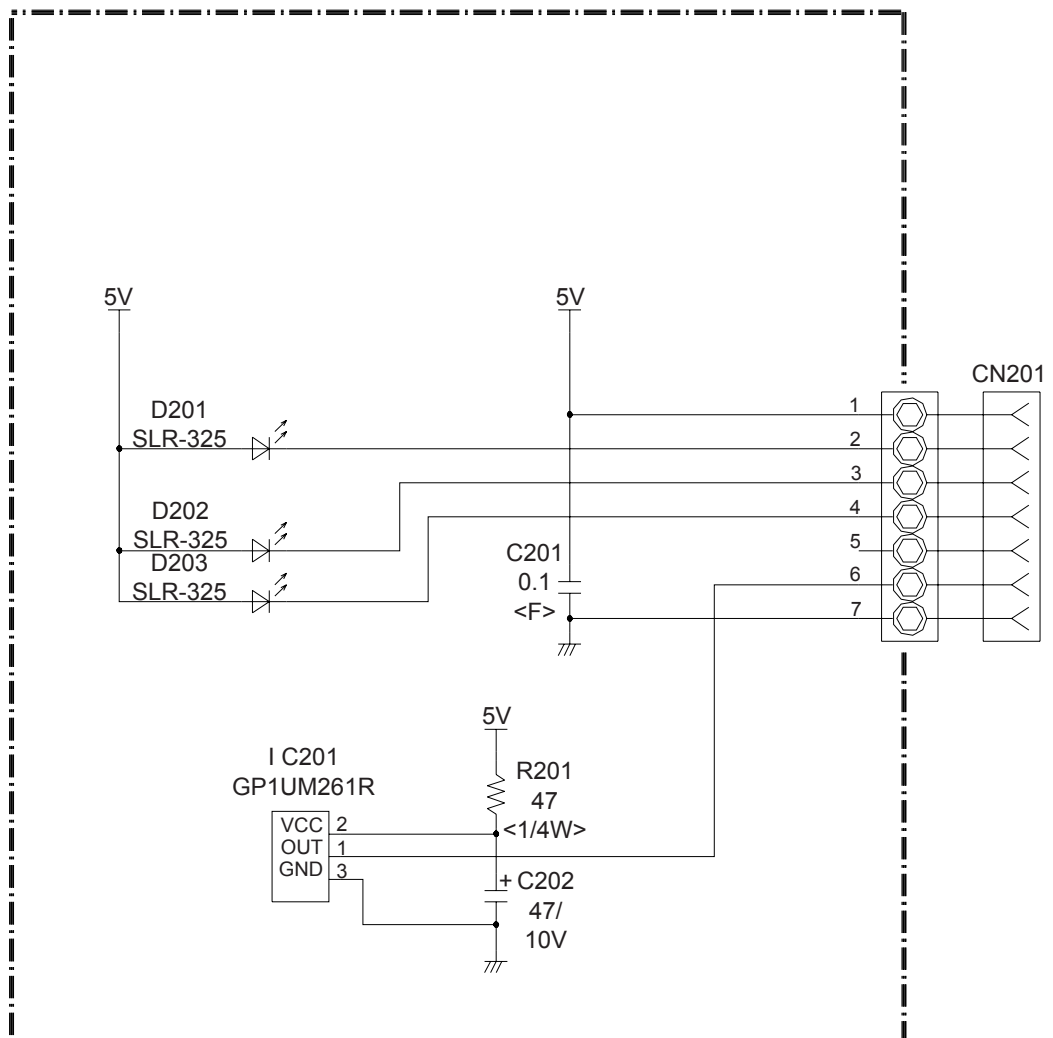

OUTDOOR PCB CIRCUIT DIAGRAM

Model : AOYR30LCT

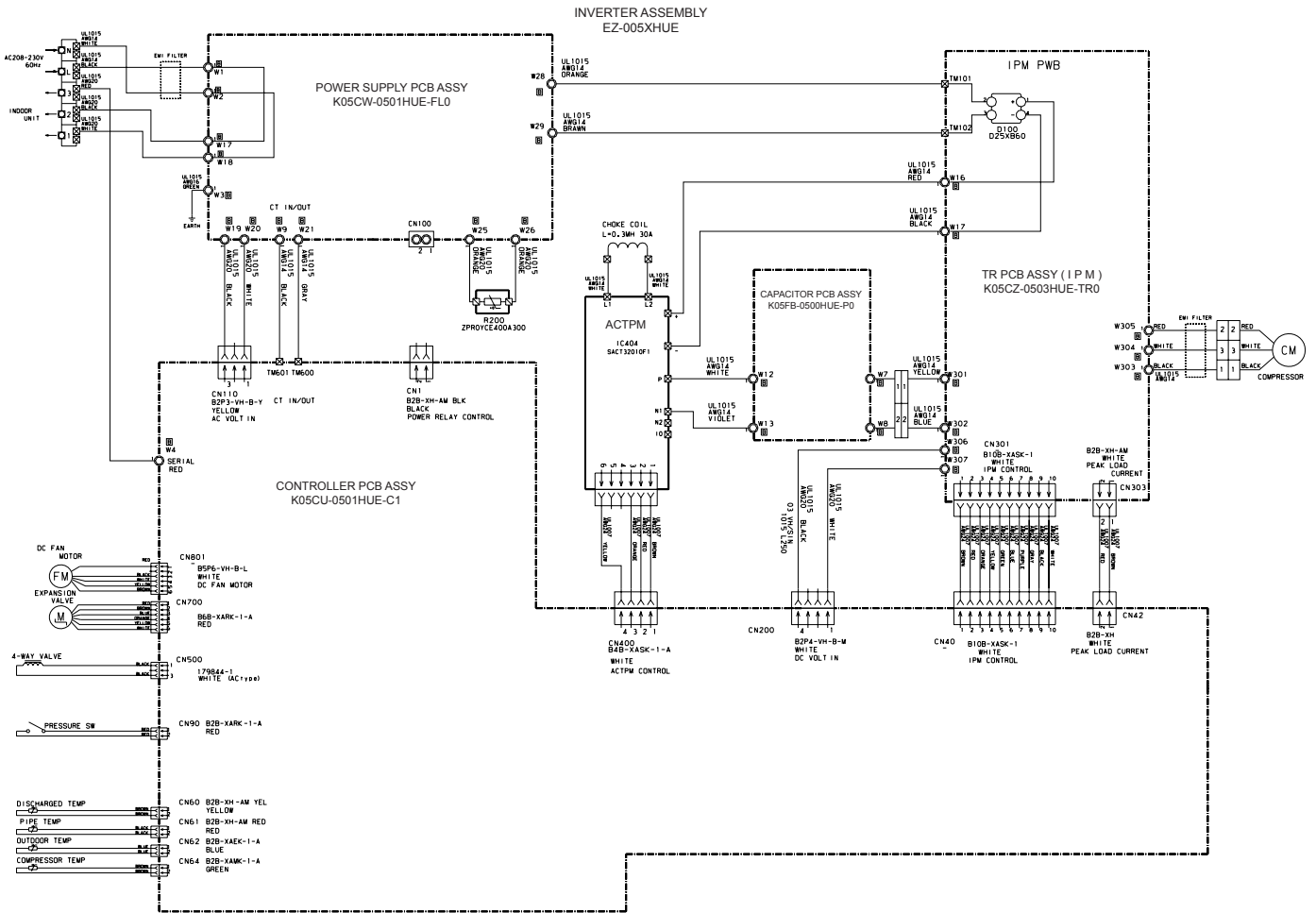

CONTROLLER PCB ASSY
K05CU-0501HUE-C1

Model : AOYR30LCT

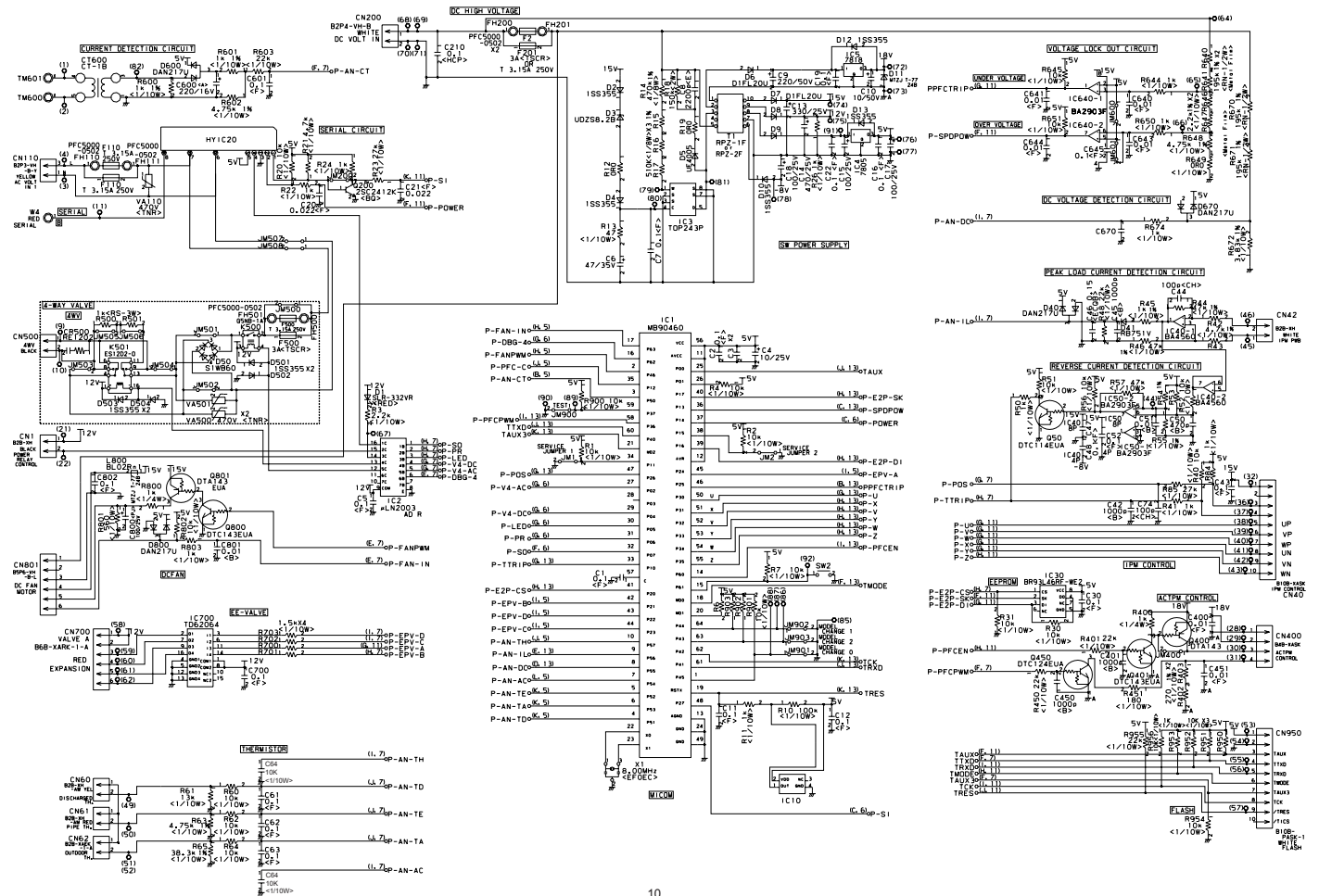

POWER SUPPLY PCB
K05CW-0501HUE-FL0

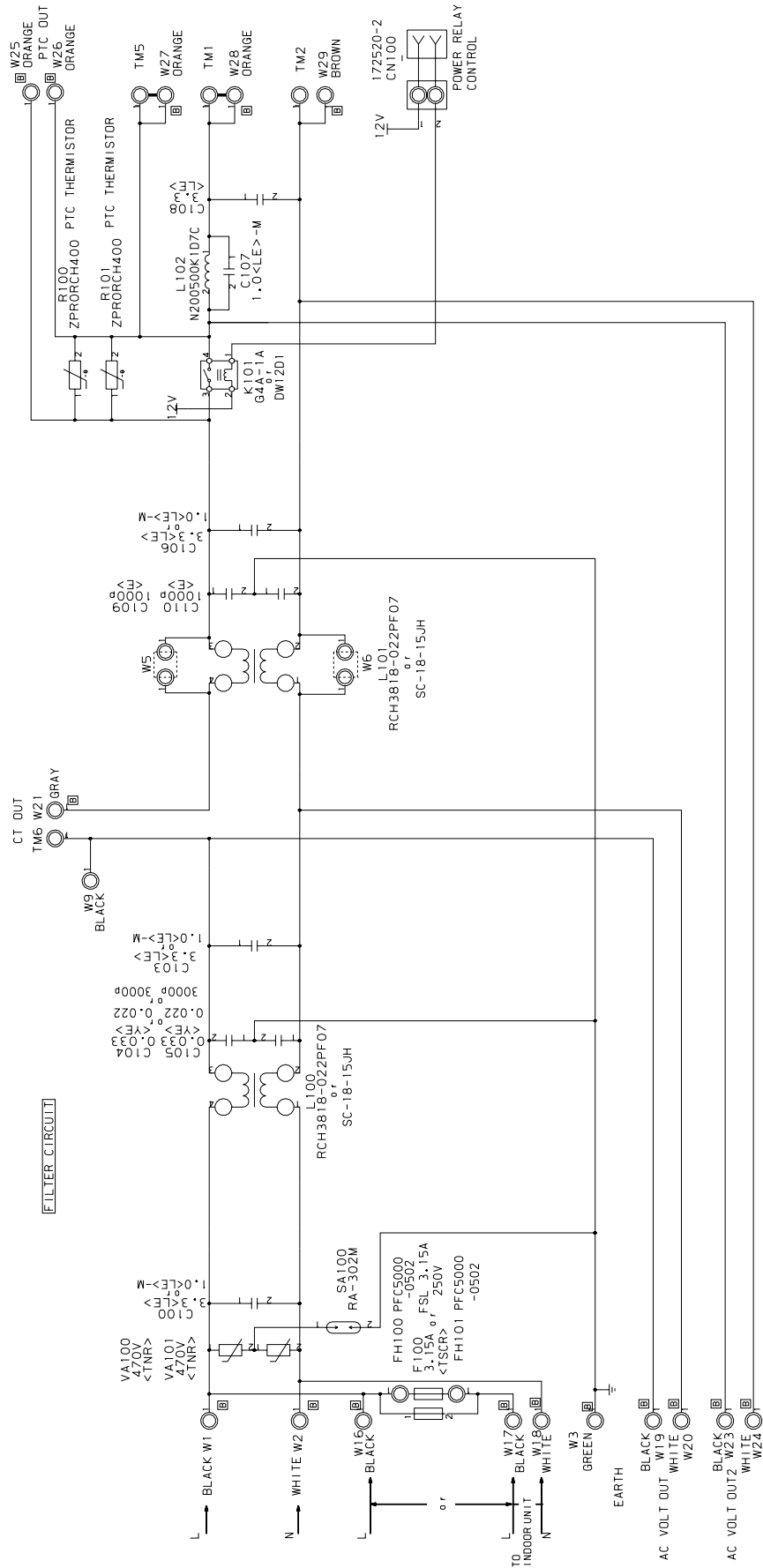

Model : AOYR30LCT

CAPACITOR PCB ASSEMBLY K05FB-0500HUE-P0

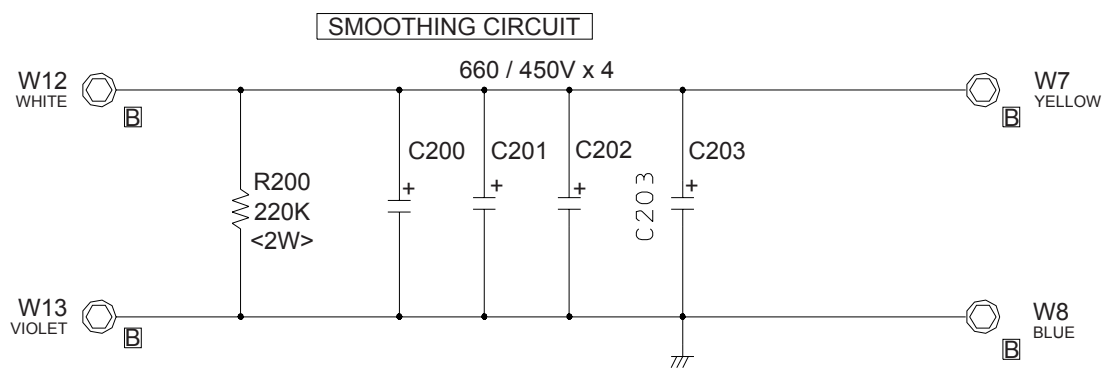

ERROR CONTENTS

Error	Display		Error
	Operation LED	Timer LED	
Serial signal error	Normal	2 flash	Serial signal (reverse) error, at operation start up
		3 flash	Serial signal (reverse) error, during operation
		4 flash	Serial signal (forward) error, at operation start up
		5 flash	Serial signal (forward) error, during operation
		8 flash	Wired remote controller error
Indoor unit thermistor error	2 flash	2 flash	Indoor temperature thermistor open / short
		3 flash	Heat exchanger middle thermistor open / short
Outdoor unit thermistor error	3 flash	2 flash	Discharge thermistor open / short
		3 flash	Heat exchanger thermistor open
		4 flash	Outdoor temperature thermistor open / short
		8 flash	Compressor temperature thermistor open / short
Indoor unit control error	4 flash	2 flash	Forced automatic SW welded
		3 flash	Main relay welded
		4 flash	Power interruption error
		7 flash	VDD permanent stop protection
		8 flash	reverse VDD permanent stop protection
Outdoor unit control error	5 flash	2 flash	Current trip error
		3 flash	CT abnormal
		5 flash	Compressor location detection error
		6 flash	Outdoor unit fan drive system abnormal
Indoor fan motor error	6 flash	2 flash	Abnormal lock
		3 flash	Abnormal rotation
Refrigerant cycle error	7 flash	2 flash	Discharge Temperature abnormal
		3 flash	Cooling high pressure abnormal rise
		5 flash	Pressure switch trouble
Optional function error	8 flash	2 flash	Active filter voltage trouble (second time)
		3 flash	Active filter voltage trouble (first time)
		4 flash	PFC circuit error
Model error	Blinking	Blinking	Model error

DISASSEMBLY ILLUSTRATION

Model : ASYA30LCC

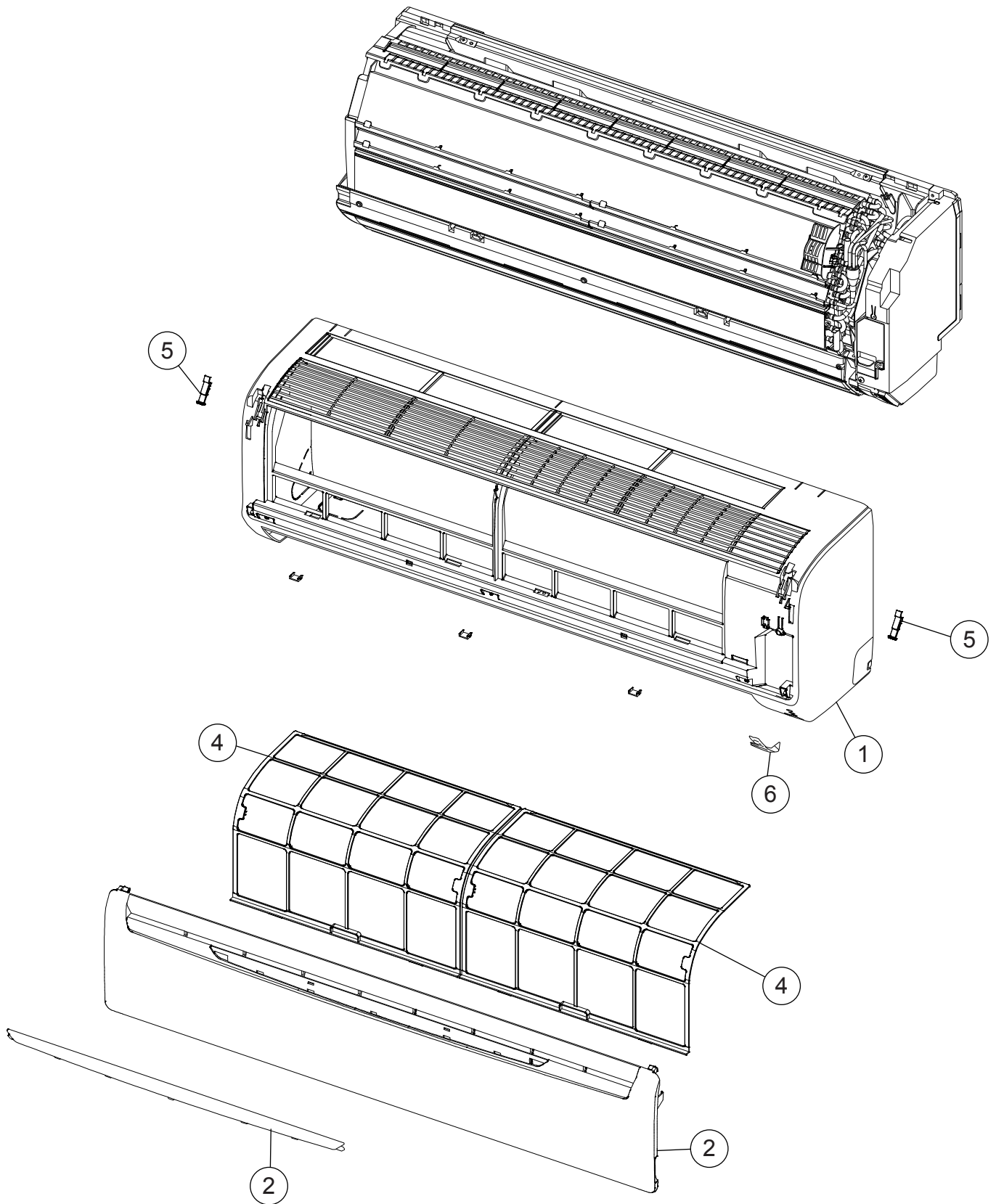

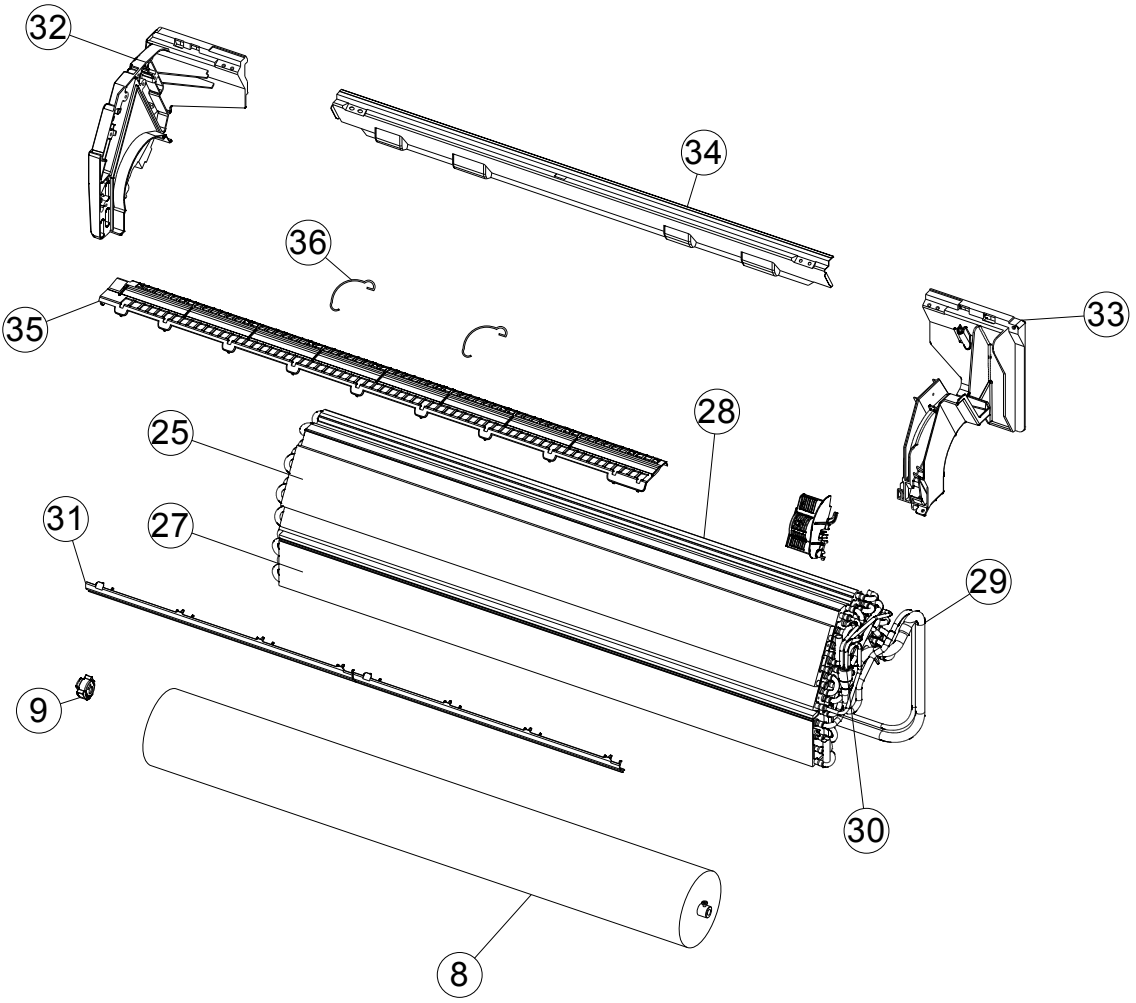

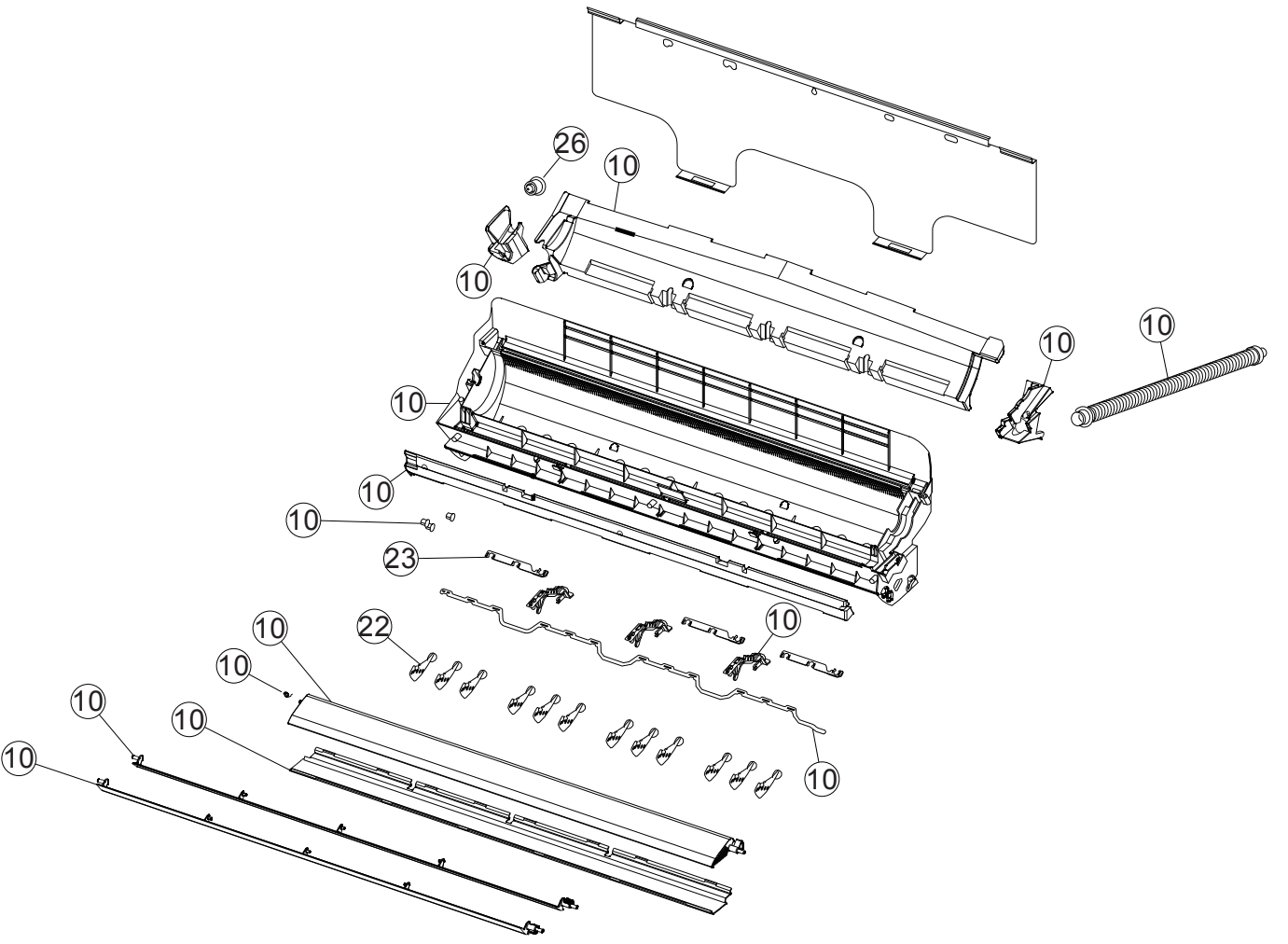

Model : ASYA30LCC

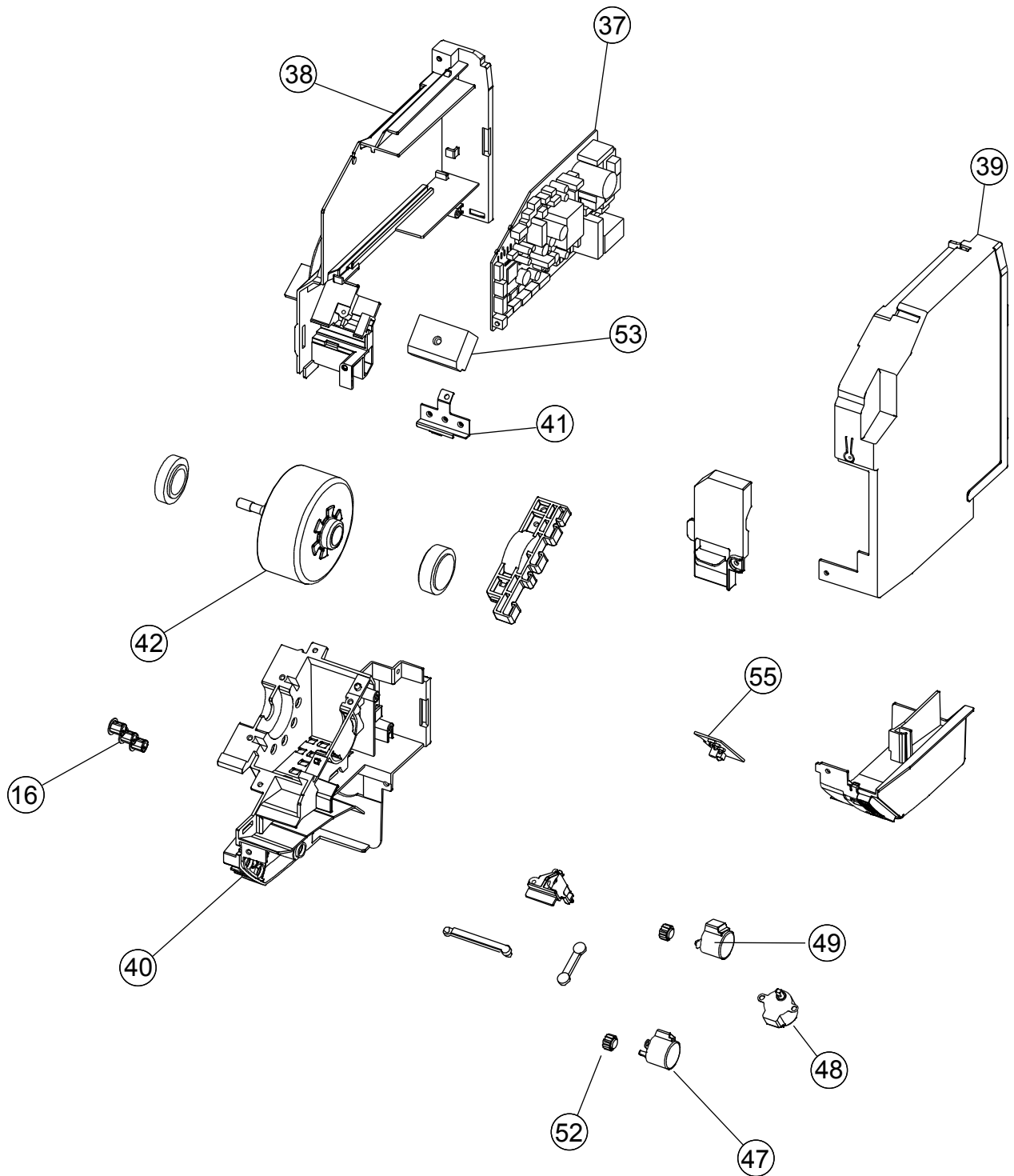

Model :
AOYR30LCT

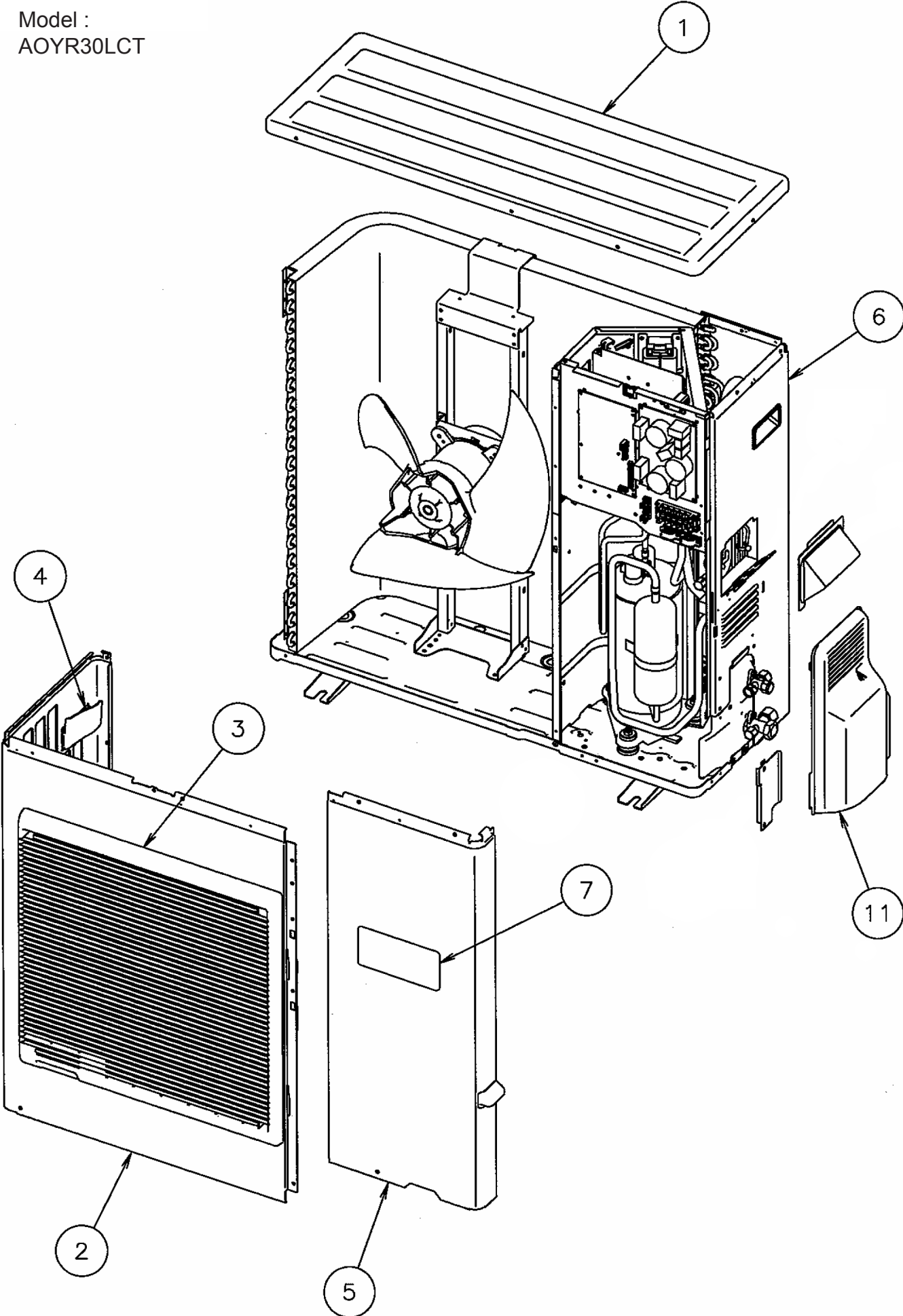

Model :
AOYR30LCT

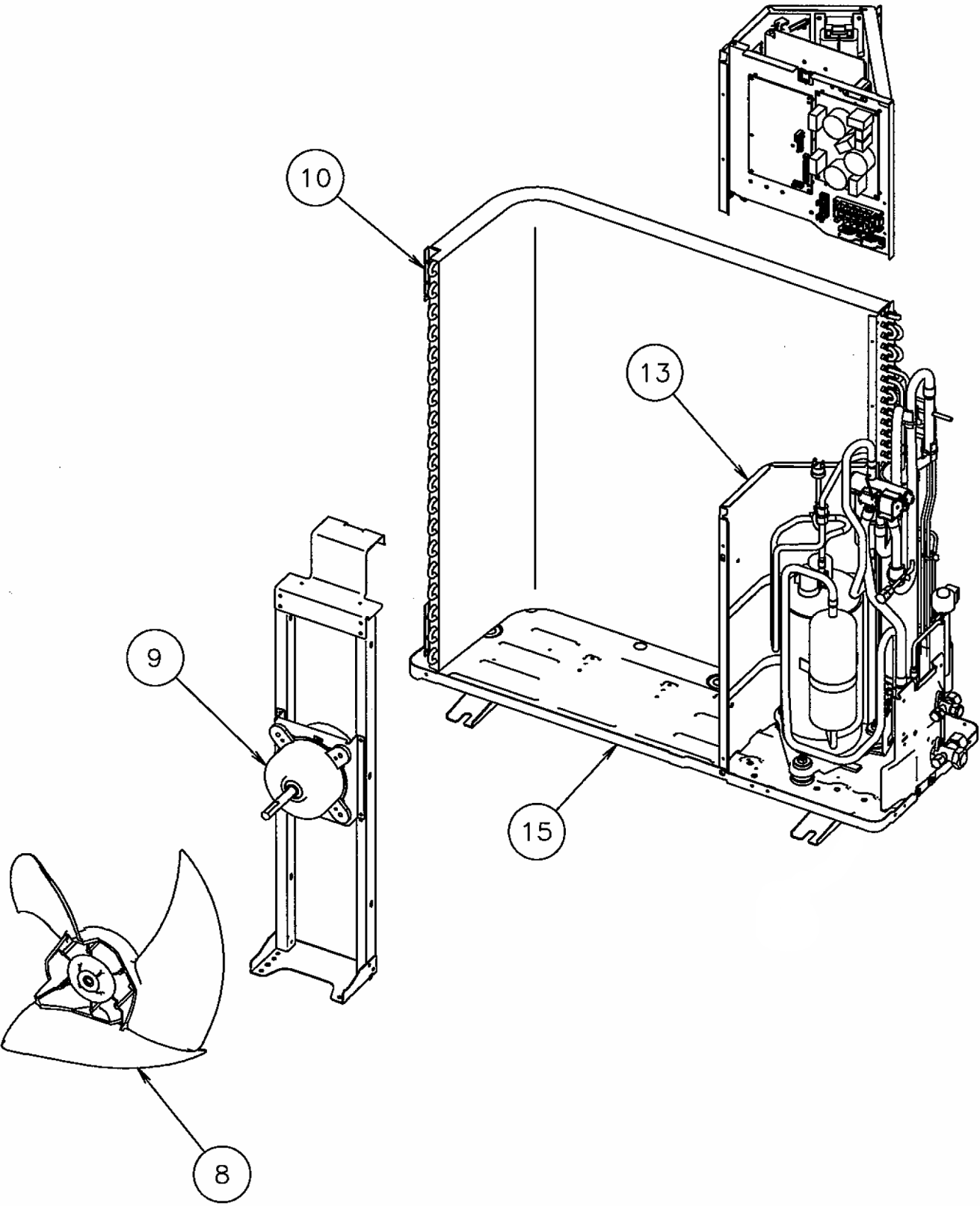

Model :
AOYR30LCT

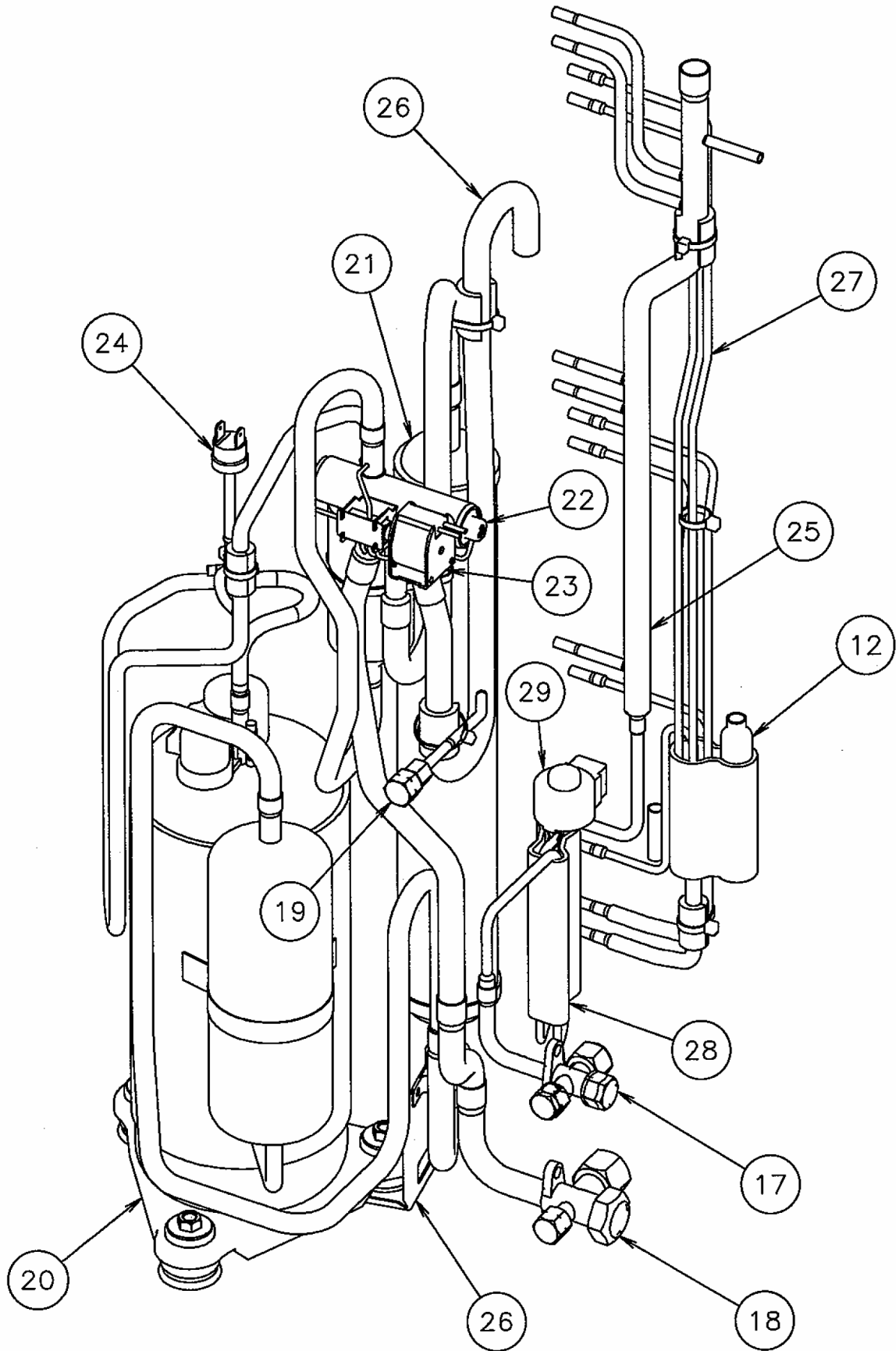

Model :
AOYR30LCT

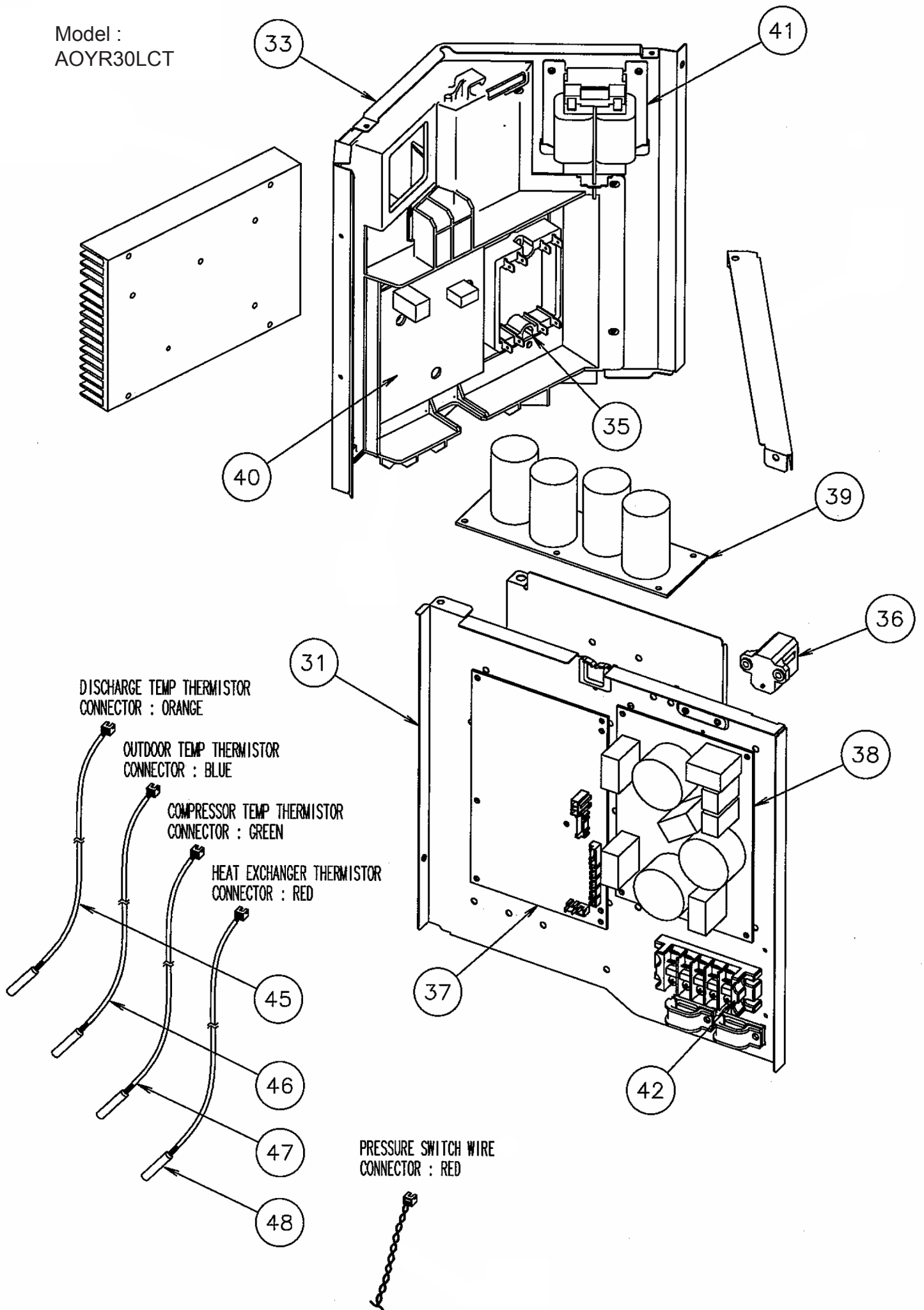

PARTS LIST







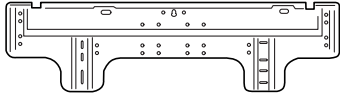

INDOOR UNIT

Ref. No.	Description	Part No.	Ord. Q'ty
		ASYA30LCC	
1	FRONT PANEL TOTAL ASSY	9315335012	
2	INTAKE GRILLE ASSY	9315336019	
4	AIR FILTER	9315014016	
5	CLAMPER(GRILLE)	9306755010	
6	RECEIVER WINDOW	9315010018	
8	CROSSFLOW FAN ASSY	9315024015	
9	BEARING C ASSY	9306628017	
10	CASING ASSY	9315331021	
22	R AND L LOUVER	9311997016	
23	SPACER B	9312441013	
25	EVAPORATOR ASSY C	9315789013	
26	DRAIN CAP	9367677009	
27	EVAPORATOR ASSY	9315348012	
28	EVAPORATOR ASSY B	9315349019	
29	CONNECTION PIPE ASSY	9315355010	
30	DISTRIBUTOR ASSY	9315351012	
31	WATER SEAL	9315251015	
32	EVAPORATER HOLDER R	9314994012	
33	EVAPORATER HOLDER L	9314995019	
34	REAR BRACKET	9315022011	
35	FILTER GUIDE	9315013019	
36	FILTER GUARD	9315411013	
37	Controller PCB ASSY	9707090062	
38	CONTROL BOX	9314996016	
39	CONTROL COVER	9314997013	
40	CASE(MOTOR)	9314998010	
41	TERMINAL(EARTH)	9315028013	
42	MOTOR,DC BRUSHLESS	9602163014	
46	MOTOR,STEP	9900384029	
47	MOTOR,STEP	9900384036	
48	MOTOR,STEP	9900139063	
52	GEAR A	9309994003	
53	TERMINAL	9900385019	
55	PWB ASSY(DISPLAY)	9707210019	

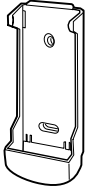
OUTDOOR UNIT

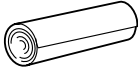
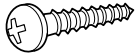
Ref. No.	Description	Part No.	Ord. Q'ty
		AOYR30LCT	
1	TOP PANEL SUB ASSY	9374417032	
2	FRONT PANEL M	9374094066	
3	FAN GUARD	9374330010	
4	GRIP SIDE	9374173013	
5	SERVICE PANEL SA	9374415052	
6	RIGHT PANEL SUB ASSY	9374416127	
7	EMBLEM-REAR	9351355005	
8	PROPELLER FAN ASSY	9366378020	
9	MOTOR,DC BRUSHLESS	9601882015	
10	CONDENSER A ASSY	9374433148	
11	VALVE COVER	9374174010	
12	STRAINER ASSY	9372524015	
13	SEPA WALL W	9374413133	
15	BASE AS PTD	9374166138	
17	3-WAY VALVE ASSY	9372205044	
18	3-WAY VALVE ASSY	9372205075	
19	CHECK JOINT ASSY	9372802038	
20	COMPRESSOR ASSY	9372558126	
21	ACCUMULATOR	9385005006	
22	4-WAY VALVE	9900164010	
23	SOLENOID	9900165079	
24	PRESSURE SWITCH	9900186012	
25	INLET PIPE(COND)A ASSY	9373461067	
26	ACCUMULATOR SUPPORT ASSY	313986353804	
27	OUTLET PIPE(COND)A ASSY	9374266104	
28	EXPANSION VALVE ASSY	9370947144	
29	COIL(EXPANSION VALVE)	9900057039	
31	CASE(PWB)AS	9375316013	
33	CASE(INVERTER)	9375314019	
35	ACTPM	9703457012	
36	THERMISTOR	9704265012	
37	CONTROLLER PCB ASSY	9707121063	
38	FILTER PCB ASSY	9707128062	
39	POWER PCB ASSY	9707257014	
40	TR PWB ASSY	9707125085	
41	COIL,CHOKE	9900366018	
42	TERMINAL	9900203023	
45	DISCHARGE TEMP THERMISTOR	9704219114	
46	THERMISTOR(OUTDOOR TEMP)	9900378028	
47	COMPRESSOR TEMP THERMISTOR	9900156022	
48	HEAT EXCHANGER THERMISTOR	9900374013	

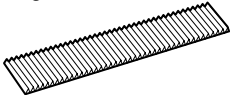
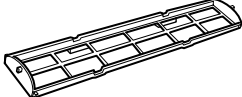
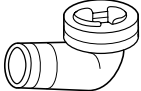
STANDARD ACCESSORIES

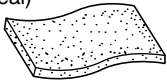
Name and Shape	Part No.
Wall hook bracket 	9315023018
Remote control unit 	9315027139
Remote control unit holder 	9305642045
Battery (penlight) 	0600185534
Cloth tape 	9310519004
Tapping screw (big) 	0700076046
Tapping screw (small) 	0700019036
Air cleaning filter 	9312153060
	9311925071
Air cleaning filter frame 	9368568009
Drain pipe (Outdoor unit) 	9301102000
Drain cap (Outdoor unit) 	313166024302
Insulation (seal) 	9374756018

0512G2980