

SPLIT TYPE ROOM AIR CONDITIONER WALL MOUNTED type

SERVICE MANUAL



Models

Indoor unit

Outdoor unit

ASYA12LCC

AOYR12LCC

CONTENTS

SPECIFICATIONS.....	1
DIMENSIONS.....	2
REFRIGERANT SYSTEM DIAGRAM.....	3
CIRCUIT DIAGRAM.....	4
INDOOR PCB CIRCUIT DIAGRAM.....	5
OUTDOOR PCB CIRCUIT DIAGRAM....	6
ERROR CONTENTS.....	8
DISASSEMBLY ILLUSTRATION.....	9
PARTS LIST.....	12
STANDARD ACCESSORIES.....	14

SPECIFICATIONS

TYPE	COOL & HEAT INVERTER
INDOOR UNIT	ASYA12LCC
OUTDOOR UNIT	AOYR12LCC
COOLING CAPACITY	3.50 kW
HEATING CAPACITY	4.80 kW

ELECTRICAL DATA

POWER SOURCE		230 V
FREQUENCY		50 Hz
RUNNING CURRENT	COOLING	4.3 A
	HEATING	5.6 A
INPUT WATTS	COOLING	0.92 kW
	HEATING	1.24 kW
E.E.R.	COOLING	3.80 kW/kW
COP	HEATING	3.87 kW/kW
MOISTURE REMOVAL (ℓ/hr)		1.8 L/hr
AIR CIRCULATION-High (m ³ /hr)	COOLING	635 m ³ /hr
	HEATING	670 m ³ /hr

COMPRESSOR

TYPE		Hermetic type, 4 pole, 3 phase, DC inverter motor, Rotary
DISCRIMINATION		DA89X1C - 20FZ
REFRIGERANT	R410A	1,050 g

FAN MOTOR

POWER SOURCE		230 V
INDOOR UNIT	HIGH-SPEED	Cool 1,370 / Heat 1,440 r.p.m.
	MED-SPEED	Cool 1,150 / Heat 1,200 r.p.m.
	LOW-SPEED	Cool 950 / Heat 1,000 r.p.m.
	QUIET	Cool 700 / Heat 760 r.p.m.
OUTDOOR UNIT		830 r.p.m.

DIMENSIONS

INDOOR UNIT	H x W x D	275 x 790 x 215 mm
OUTDOOR UNIT	H x W x D	540 x 790 x 290 mm

WEIGHT

INDOOR UNIT	GROSS / NET	12 / 9 kg
OUTDOOR UNIT	GROSS / NET	41 / 37 kg

NOISE LEVEL

INDOOR UNIT	High	Cool 42 dB / Heat 42 dB
	Med	Cool 36 dB / Heat 35 dB
	Low	Cool 30 dB / Heat 29 dB
	Quiet	Cool 21 dB / Heat 21 dB
OUTDOOR UNIT		Cool 47 dB / Heat 49 dB

REFRIGERANT (R410A)

	Pipe Length	15 m	1,050 g
FULL CHARGE AMOUNT		20 m	1,150 g
	ADDITIONAL REFRIGERANT		20 g / m
MAXIMUM PIPING HEIGHT			15m

DIMENSIONS

Models : ASYA12LCC / AOYR12LCC

(unit : mm)

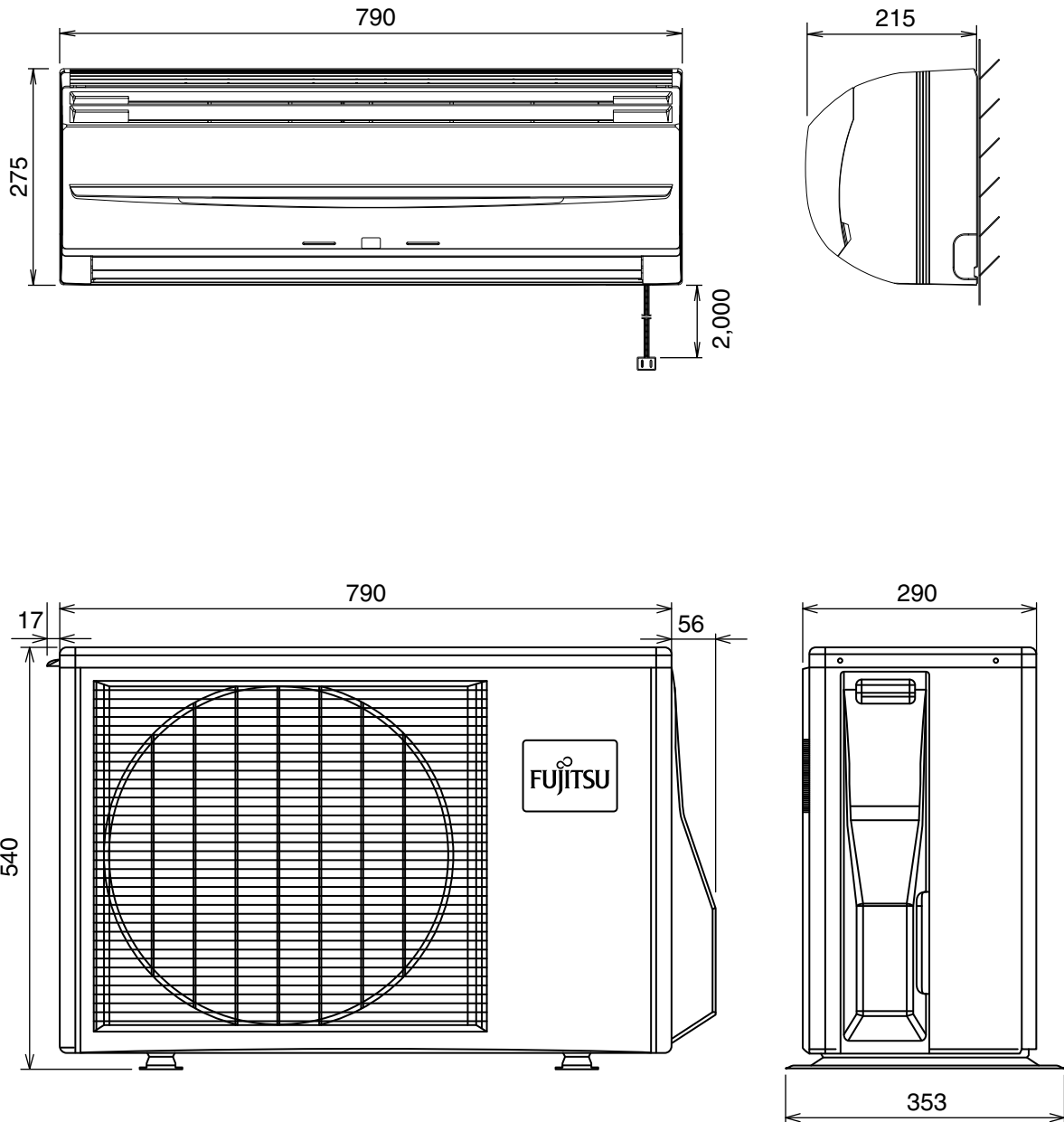

REFRIGERANT SYSTEM DIAGRAM

Models : ASYA12LCC / AOYR12LCC

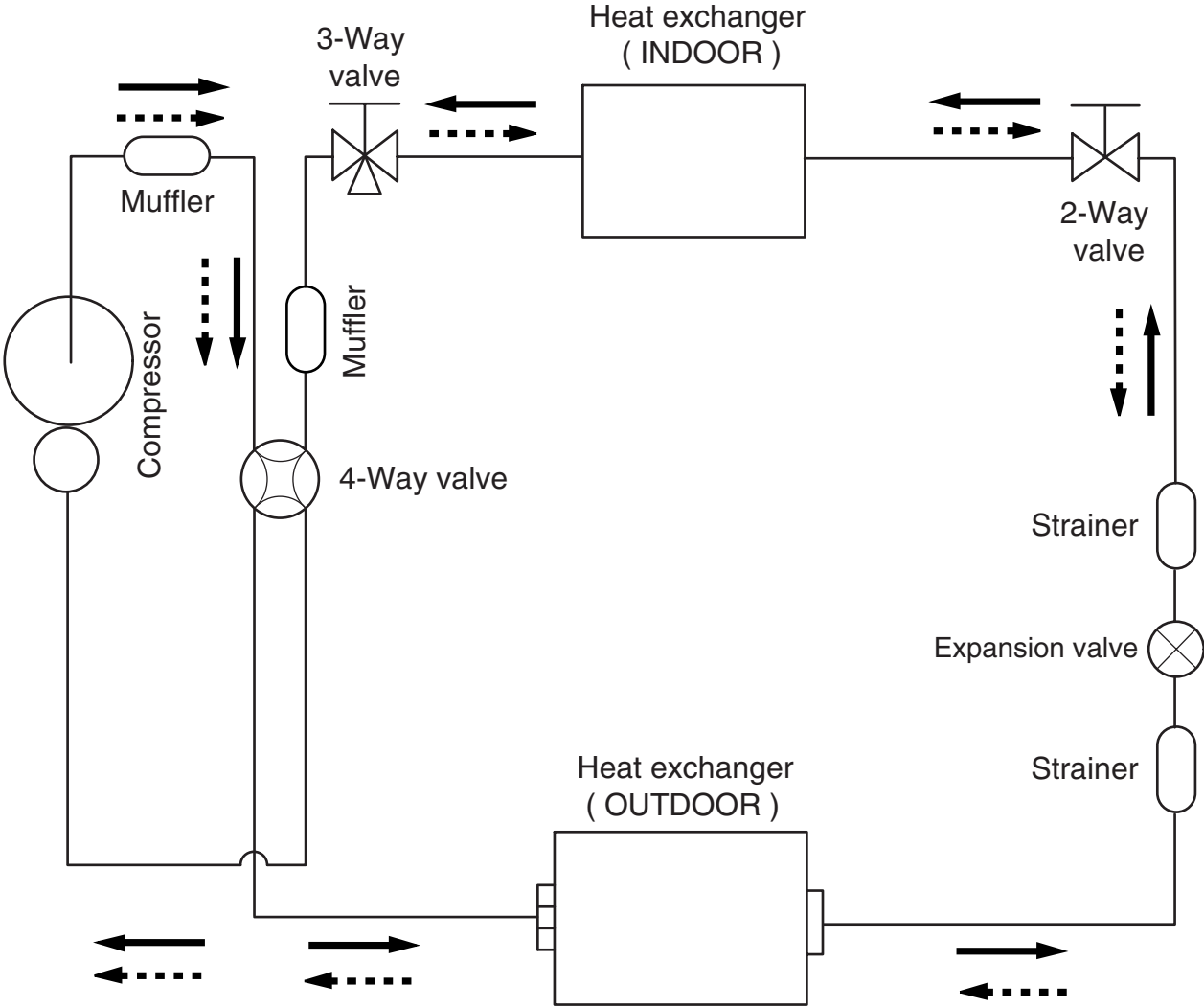

———→ Cooling
→ Heating

Refrigerant pipe diameter
 Liquid : 1/4" (6.35 mm)
 Gas : 3/8" (9.52 mm)

CIRCUIT DIAGRAM

Models : ASYA12LCC / AOYR12LCC

INDOOR UNIT

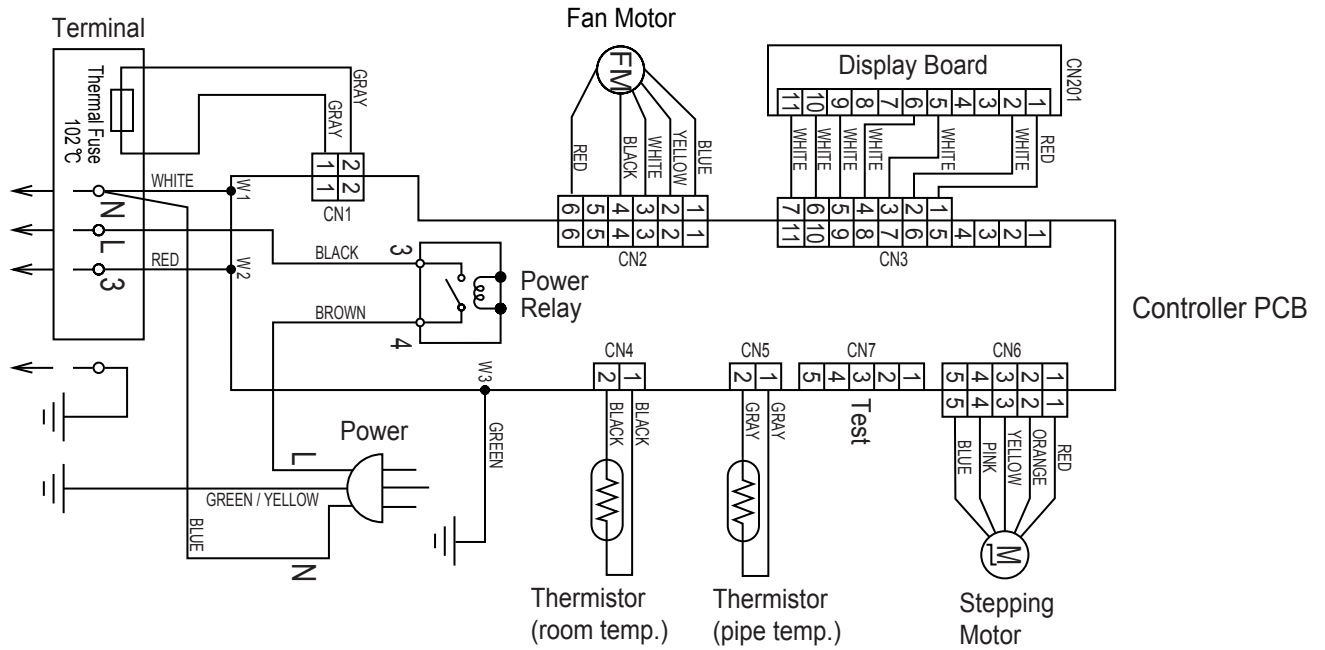

OUTDOOR UNIT

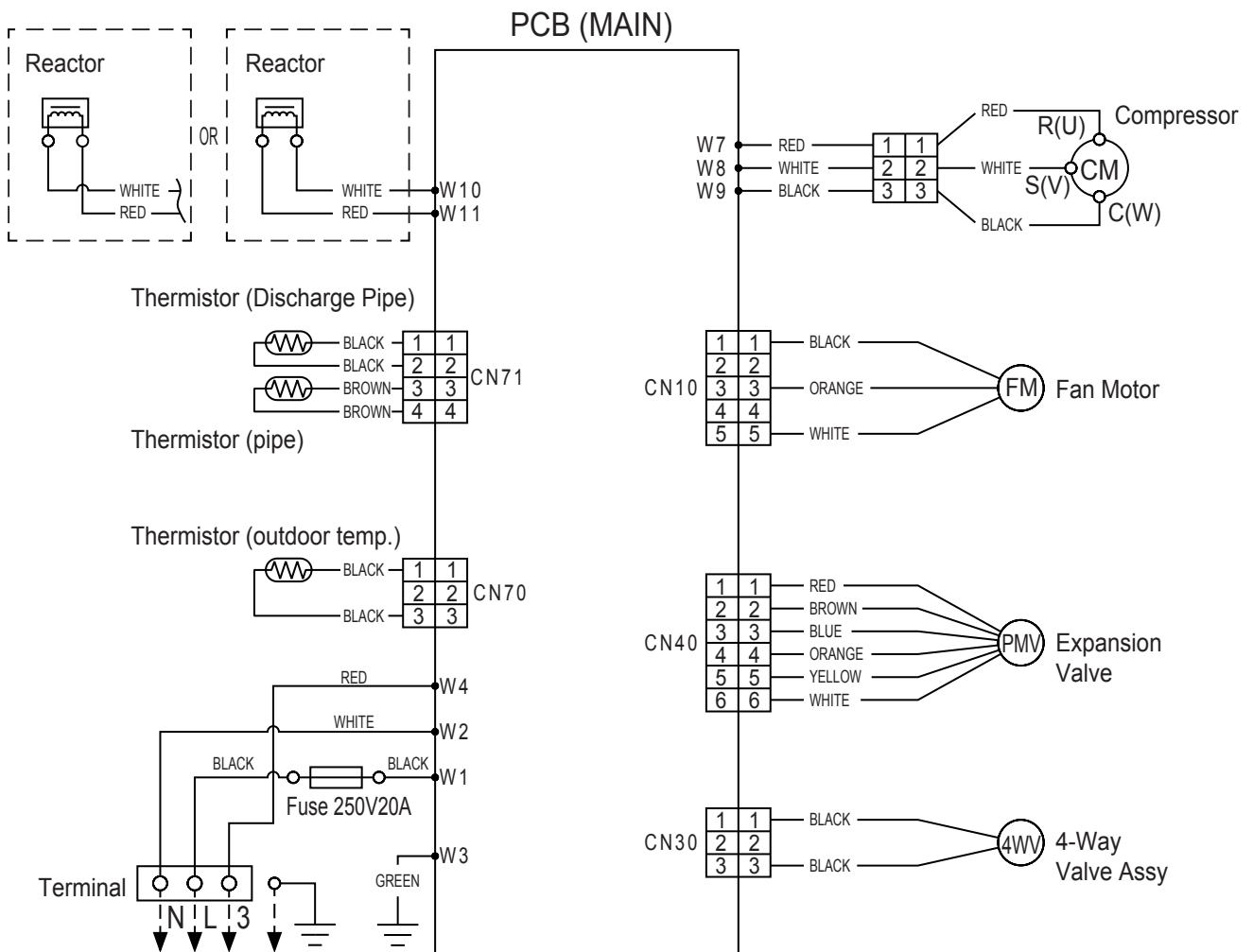

INDOOR PCB CIRCUIT DIAGRAM

Model : ASYA12LCC

Jumper wire configurations

Switch	Function	ON/Linked	OFF/Open
JM1	Custom code	A	B
JM2	Auto restart	enable	disable

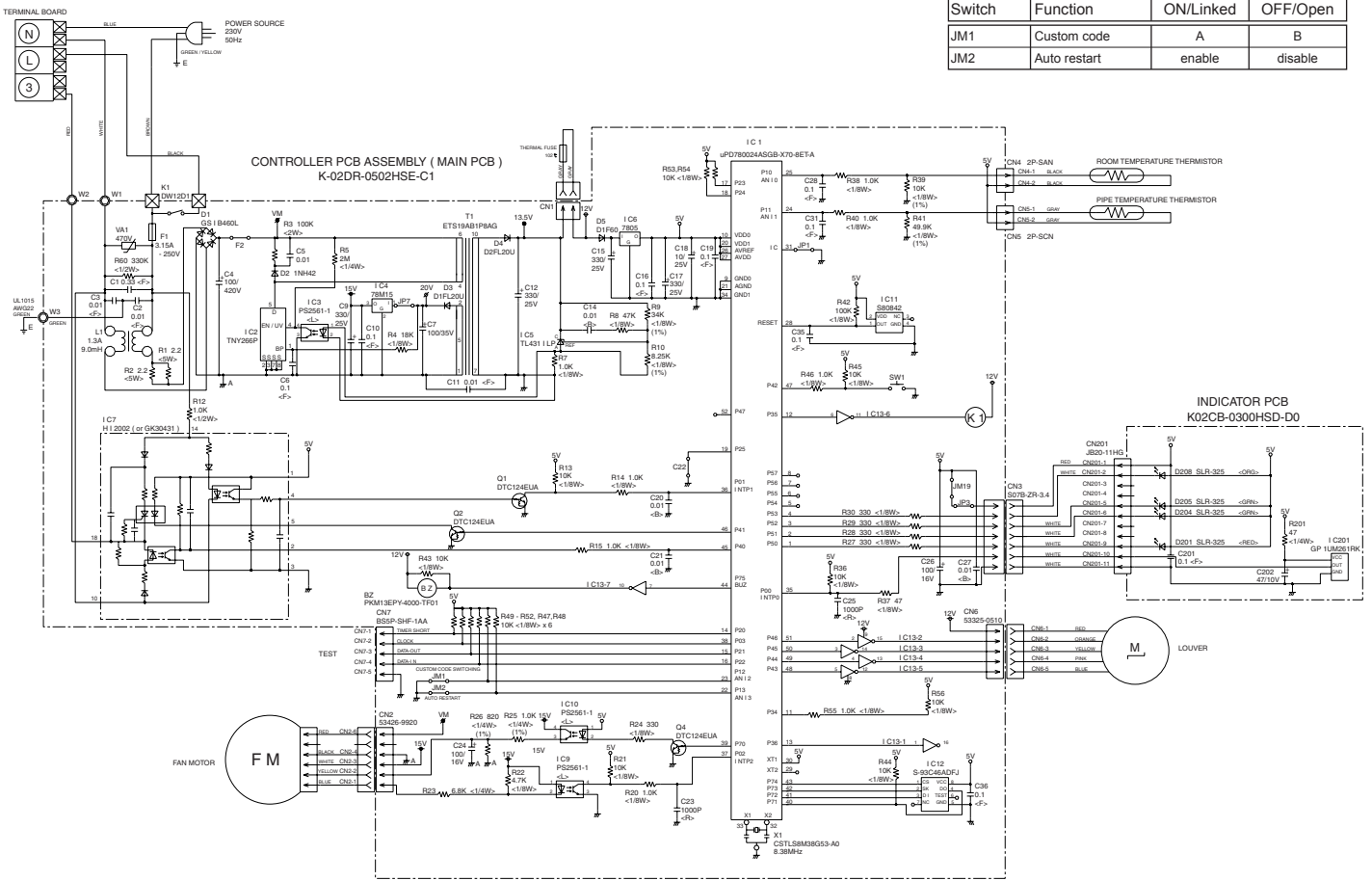

OUTDOOR PCB CIRCUIT DIAGRAM

Model : AOYR12LCC

INVERTER ASSEMBLY EZ-0054HUE

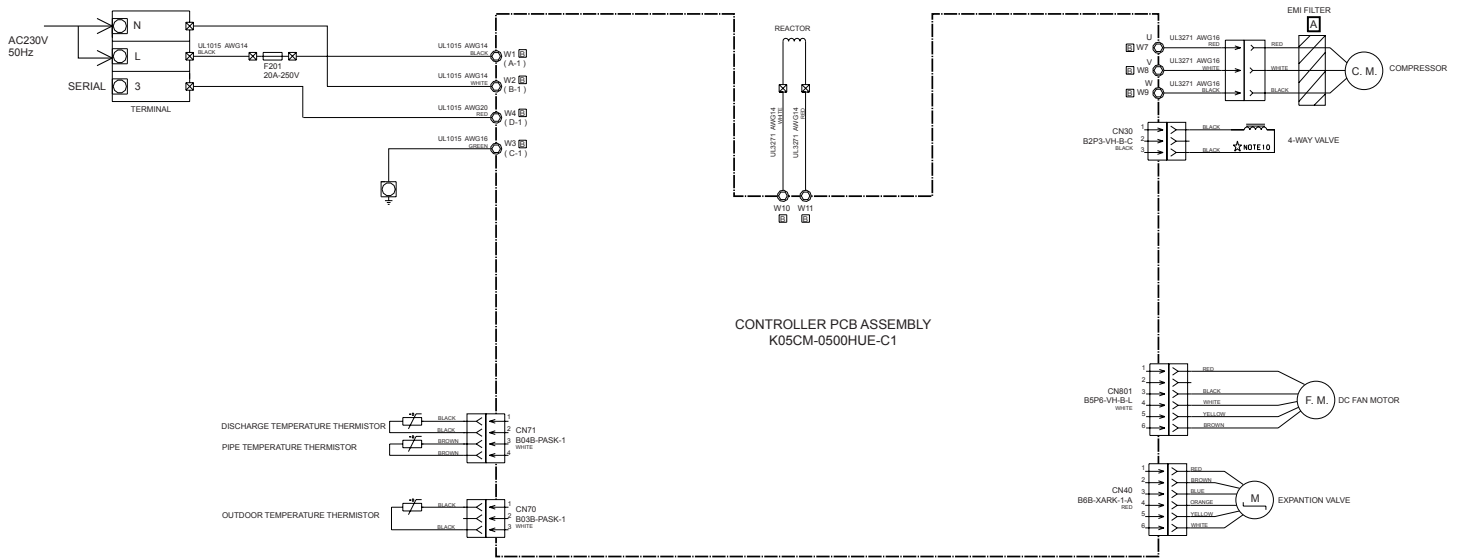

CONTROLLER PCB ASSEMBLY
K05CM-0500HUE-C1

Model : AOYR12LCC

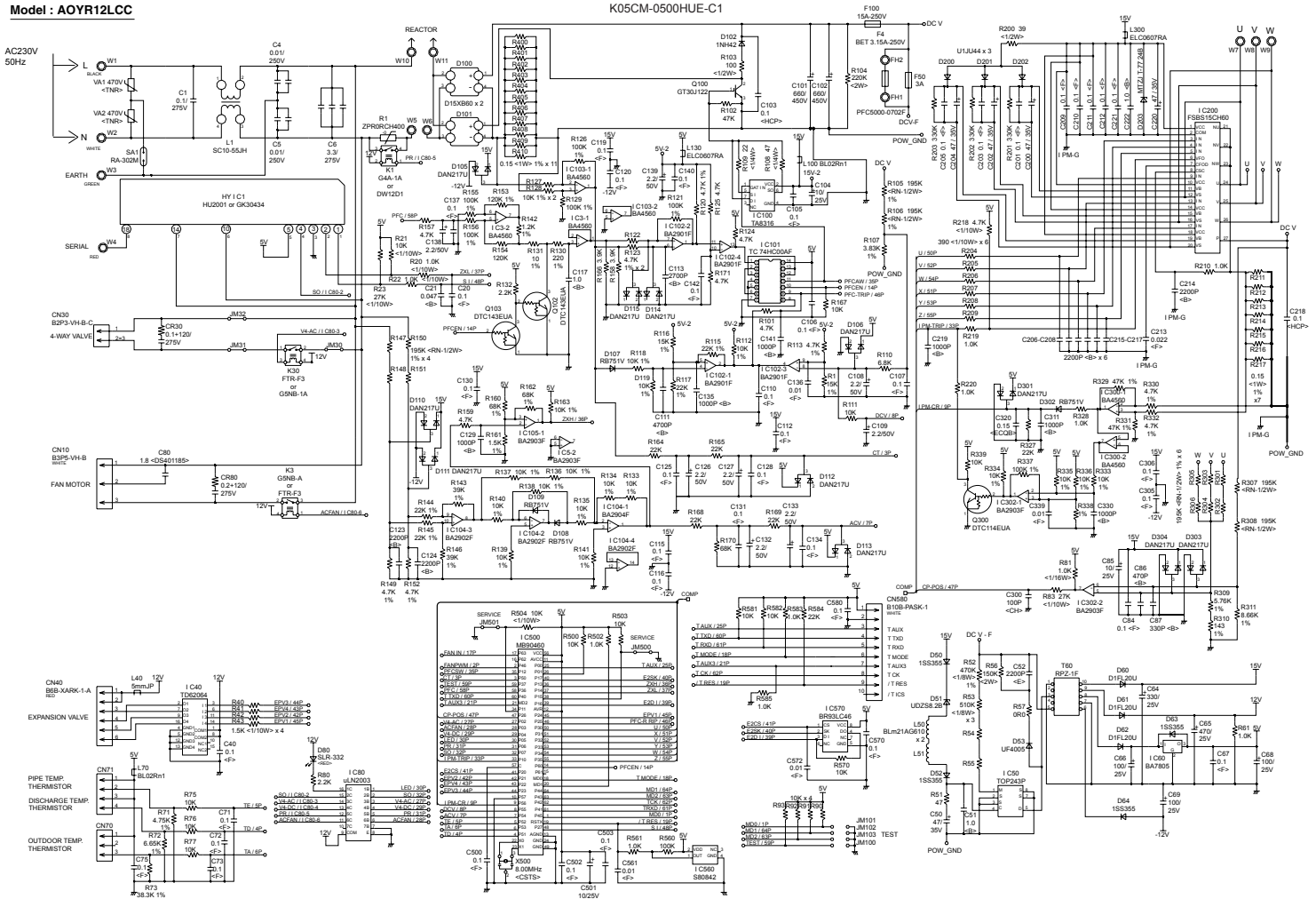

ERROR CONTENTS

Model : ASYA12LCC

Error	Display		Error
	Operation LED	Timer LED	
Serial signal error	Normal	2 flash	Serial signal (reverse) error, at operation start up
		3 flash	Serial signal (reverse) error, during operation
		4 flash	Serial signal (forward) error, at operation start up
		5 flash	Serial signal (forward) error, during operation
Indoor unit thermistor error	2 flash	2 flash	Indoor temperature thermistor open / short
		3 flash	Heat exchanger middle thermistor open / short
Outdoor unit thermistor error	3 flash	2 flash	Discharge thermistor open / short
		3 flash	Heat exchanger thermistor open
		4 flash	Outdoor temperature thermistor open / short
Indoor unit control error	4 flash	2 flash	Forced automatic SW welded
		3 flash	Main relay welded
		4 flash	Power interruption error
		7 flash	VDD permanent stop protection
Outdoor unit control error	5 flash	8 flash	reverse VDD permanent stop protection
		2 flash	Current trip error
		3 flash	CT abnormal
		5 flash	Compressor location detection error
Indoor fan motor error	6 flash	6 flash	Outdoor unit fan drive system abnormal
		2 flash	Abnormal lock
Refrigerant cycle error	7 flash	3 flash	Abnormal rotation
		2 flash	Discharge Temperature abnormal
Optional function error	8 flash	3 flash	Cooling high pressure abnormal rise
		4 flash	PFC circuit error
Model error	Blinking	Blinking	Model error

DISASSEMBLY ILLUSTRATION

Model : ASYA12LCC

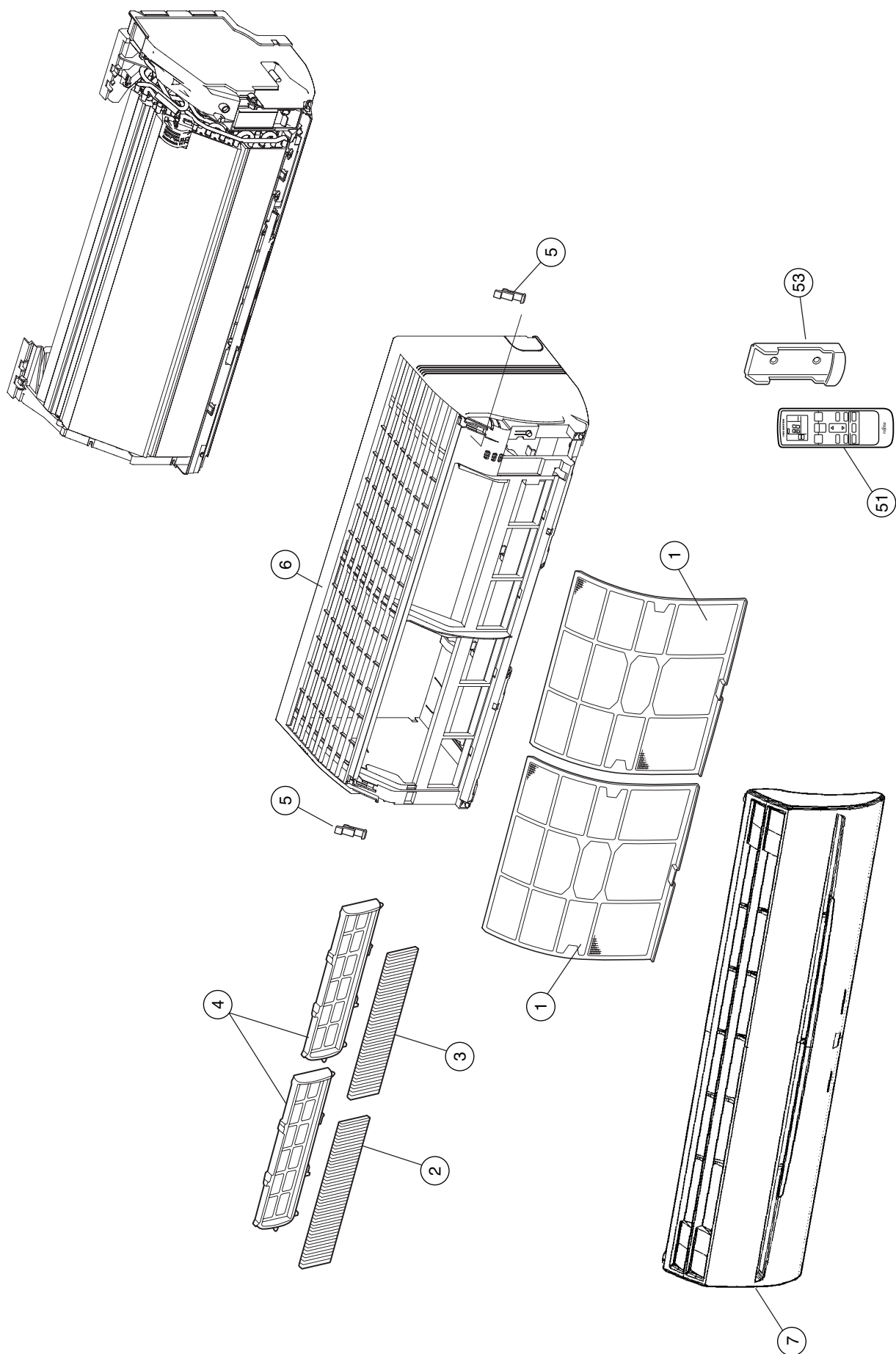

Model : ASYA12LCC

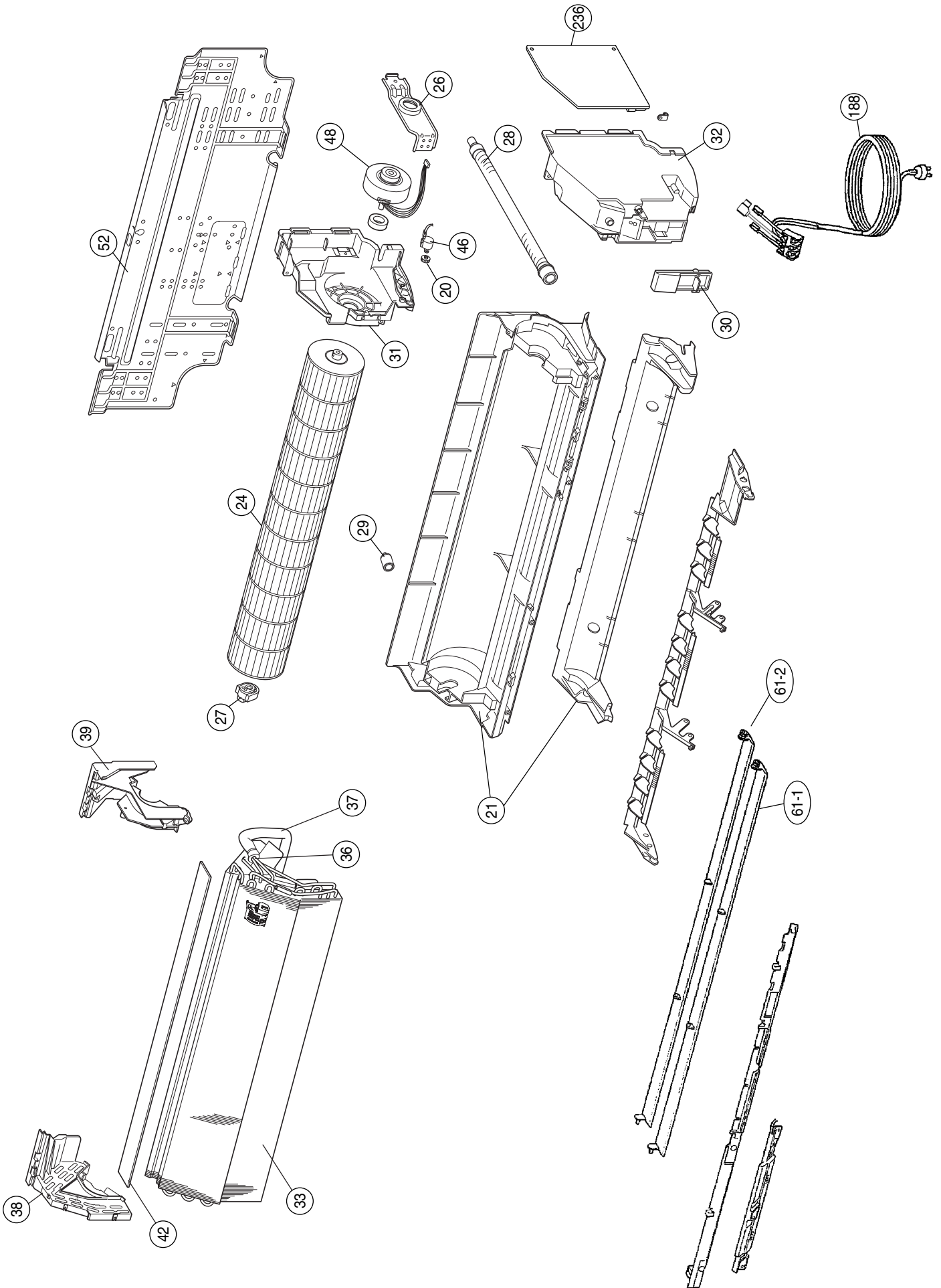

Model : AOYR12LCC

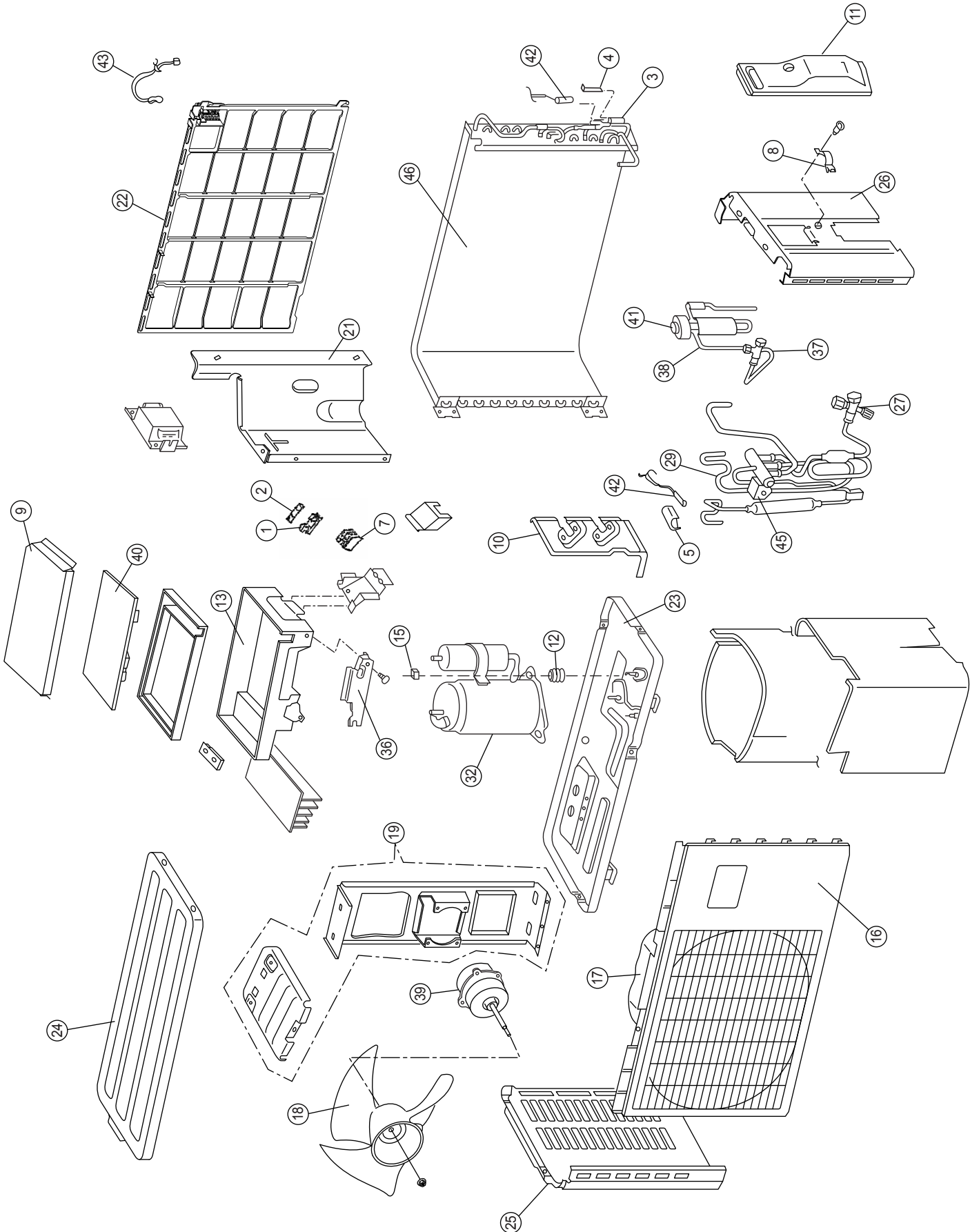

PARTS LIST







INDOOR UNIT

Ref. No.	Description	Part No.	Ord. Q'ty
		ASYA12LCC	
1	Air Filter	9309997011	
2	Filter (Electric)	9312153015	
3	Filter (ION)	9311925033	
4	Holder (Filter)	9306602017	
5	Clamper (Grille)	9306755010	
6	Front Panel Total Assy	9313130169	
7	Intake Grille Assy	9313131128	
20	Gear-A	9309994003	
21	Casing Assy	9311354079	
24	Crossflow Fan Assy	9307836015	
26	Clamp (Motor)	9310102008	
27	Shaft Holder-C Assy	9306628017	
28	Drain Hose Assy	9314147012	
29	Drain Cap Assy	9314493010	
30	Wire Clamper	9311946014	
31	Box (Switch)	9312908011	
32	Cover (Switch)	9312909018	
33	Evaporator Total Assy	9313099015	
36	Joint Pipe Assy	9313104016	
37	Insulation (Pipe)-E	9304607007	
38	Holder (Evaporator)-L	9309982017	
39	Holder (Evaporator)-R	9309983014	
42	Air Seal	9310611005	
46	Step Motor	9900139025	
48	Fan Motor Assy	9601814016	
51	Remote Control Unit	9315027030	
52	Bracket Panel	9310001004	
53	Remote Control Unit Holder	9305642045	
61-1	Flow Control Panel-U	9309991033	
61-2	Flow Control Panel-Z	9309992030	
188	Power Cord Assy (Power Cord+Terminal)	9900339012	
236	Controller PCB Assy	9705656093 (K02DR-0502HSE-C1)	
---	Pipe Temperature Thermistor	9702039042	
---	Room Temperature Thermistor	9700801108	
---	Indicator PCB Assy	9705039032	

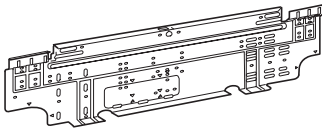
OUTDOOR UNIT

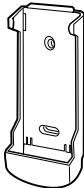
Ref. No.	Description	Part No.	Ord. Q'ty
		AOYR12LCC	
1	Fuse Holder	0501454012	
2	Fuse	0600382018	
3	Thermister Holder Pipe	313714262805	
4	Thermistor Spring-A	313728262708	
5	Thermistor Spring	9300089012	
7	Terminal	9306489038	
8	Cord Clamp	9307271014	
9	Cover (Case)	9309913011	
10	Bracket Valve	9310229026	
11	Cover (Switch)	9310979013	
12	Rubber Cushion	9312680016	
13	Inverter Case Assy	9312972029	
15	Nut Special Assy	9313452018	
16	Front Panel	9313806026	
17	Fan Ring	9313807016	
18	Propeller Fan	9313808013	
19	Bracket (Motor) Assy	9313990015	
21	Separator-B	9313815011	
22	Protective Net	9313941017	
23	Base Assy (Painted)	9313987015	
24	Top Panel (Painted)	9313989026	
25	Cabinet Left (Painted)	9313992019	
26	Cabinet Right (Painted)	9313995027	
27	3-Way Valve Assy	9314022012	
29	4-Way Valve Assy	9314093012	
32	Compressor Assy	9315206015	
36	Cover (Inverter Case)	9314507014	
37	2-Way Valve Assy	9314554018	
38	Pulse Motor Valve Assy	9314557019	
39	Motor	9602117017	
40	Inverter PCB Assy	9707039016	
41	Expansion Valve Coil	9900057039	
42	Thermistor Assy	9900148027	
43	Thermistor (Outdoor Temp)	9900210038	
45	Solenoid	9970033018	
46	Condenser Assy	9314106019	
---	Emblem Rear	9315210012	

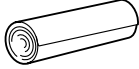
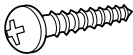
STANDARD ACCESSORIES

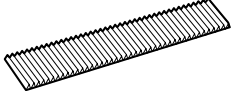
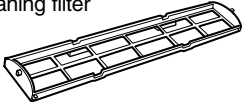
Name and Shape	Part No.
	ASYA12LCC
Wall hook bracket 	9310001004
Remote control unit 	9315027030
Remote control unit holder 	9305642045
Battery (penlight) 	0600185534
Cloth tape 	9310519004
Tapping screw (big) (φ 4 x 25) 	0700076046
Tapping screw (small) (φ 3 x 12) 	0700019036
Air cleaning filter 	9312153015
	9311925033
Air cleaning filter frame 	9306602017

0512G2961