

**SPLIT TYPE  
ROOM AIR CONDITIONER  
WALL MOUNTED type**

# SERVICE MANUAL



## Models

### Indoor unit

ASYA07LCC

ASYA09LCC

### Outdoor unit

AOYR07LCC

AOYR09LCC

## CONTENTS

SPECIFICATIONS.....	1
DIMENSIONS.....	2
REFRIGERANT SYSTEM DIAGRAM.....	3
CIRCUIT DIAGRAM.....	4
INDOOR PCB CIRCUIT DIAGRAM.....	5
OUTDOOR PCB CIRCUIT DIAGRAM ...	6
ERROR CONTENTS.....	8
DISASSEMBLY ILLUSTRATION.....	9
PARTS LIST.....	14
STANDARD ACCESSORIES .....	16

# SPECIFICATIONS

<b>TYPE</b>	COOL & HEAT INVERTER	
<b>INDOOR UNIT</b>	ASYA07LCC	ASYA09LCC
<b>OUTDOOR UNIT</b>	AOYR07LCC	AOYR09LCC
<b>COOLING CAPACITY</b>	2.10 kW	2.60 kW
<b>HEATING CAPACITY</b>	3.00 kW	3.60 kW

## ELECTRICAL DATA

<b>POWER SOURCE</b>		230 V	230 V
<b>FREQUENCY</b>		50 Hz	50 Hz
<b>RUNNING CURRENT</b>	COOLING	2.5 A	3.2 A
	HEATING	3.2 A	4.0 A
<b>INPUT WATTS</b>	COOLING	0.47 kW	0.655 kW
	HEATING	0.66 kW	0.845 kW
<b>E.E.R.</b>	COOLING	4.47 kW/kW	3.97 kW/kW
<b>COP</b>	HEATING	4.55 kW/kW	4.26 kW/kW
<b>MOISTURE REMOVAL</b>		1.0 L/hr	1.3 L/hr
<b>AIR CIRCULATION -High</b>	COOLING	595 m³/hr	595 m³/hr
	HEATING	645 m³/hr	645 m³/hr

## COMPRESSOR

<b>TYPE</b>	Hermetic type, 4 pole, 3 phase, DC inverter motor, Rotary	
<b>DISCRIMINATION</b>	DA89X1C - 20FZ	
<b>REFRIGERANT</b>	R410A	900 g

## FAN MOTOR

<b>POWER SOURCE</b>	230 V	
<b>INDOOR UNIT</b>	HIGH-SPEED	Cool 1,300 / Heat 1,390 r.p.m.
	MED-SPEED	Cool 1,120 / Heat 1,200 r.p.m.
	LOW-SPEED	Cool 950 / Heat 1,000 r.p.m.
	QUIET	Cool 700 / Heat 760 r.p.m.
<b>OUTDOOR UNIT</b>	800 r.p.m.	

## DIMENSIONS

<b>INDOOR UNIT</b>	H x W x D	275 x 790 x 215 mm
<b>OUTDOOR UNIT</b>	H x W x D	540 x 660 x 290 mm

## WEIGHT

<b>INDOOR UNIT</b>	GROSS / NET	12 / 9 kg
<b>OUTDOOR UNIT</b>	GROSS / NET	35 / 32 kg

## NOISE LEVEL

<b>INDOOR UNIT</b>	High	Cool 41 dB / Heat 41 dB
	Med	Cool 36 dB / Heat 36 dB
	Low	Cool 30 dB / Heat 30 dB
	Quiet	Cool 21 dB / Heat 21 dB
<b>OUTDOOR UNIT</b>		Cool 47 dB / Heat 48 dB

## REFRIGERANT (R410A)

	Pipe Length	15 m	900 g
<b>FULL CHARGE AMOUNT</b>		20 m	1,000 g
<b>ADDITIONAL REFRIGERANT</b>			20 g / m
<b>MAXIMUM PIPING HEIGHT</b>			15m

# DIMENSIONS

Models :  
ASYA07LCC / AOYR07LCC  
ASYA09LCC / AOYR09LCC

(unit : mm)

## INDOOR UNIT

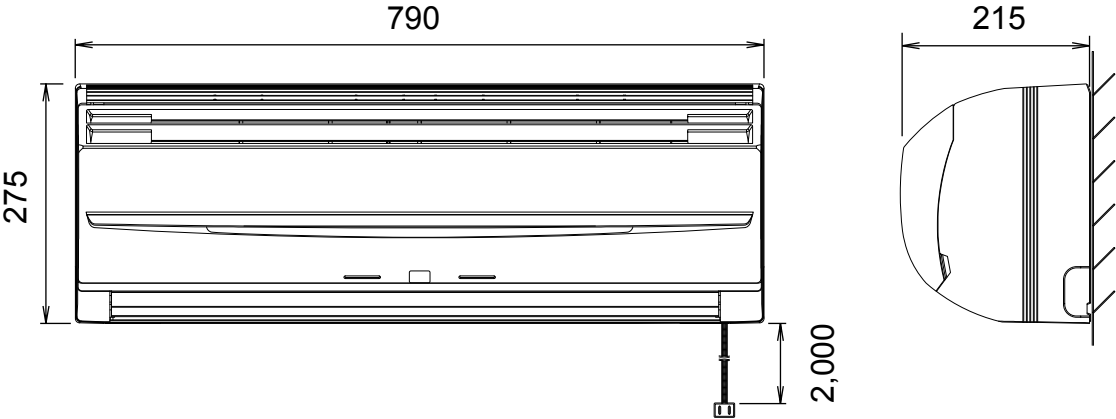

## OUTDOOR UNIT

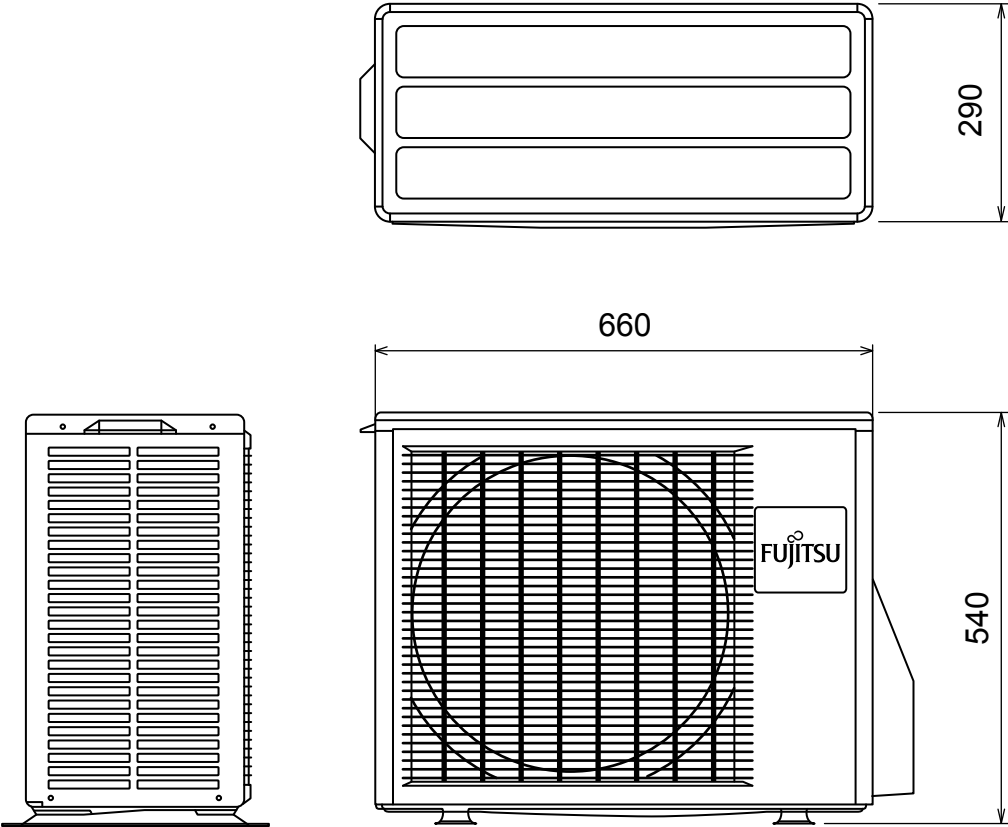

# REFRIGERANT SYSTEM DIAGRAM

Models :  
 ASYA07LCC / AOYR07LCC  
 ASYA09LCC / AOYR09LCC

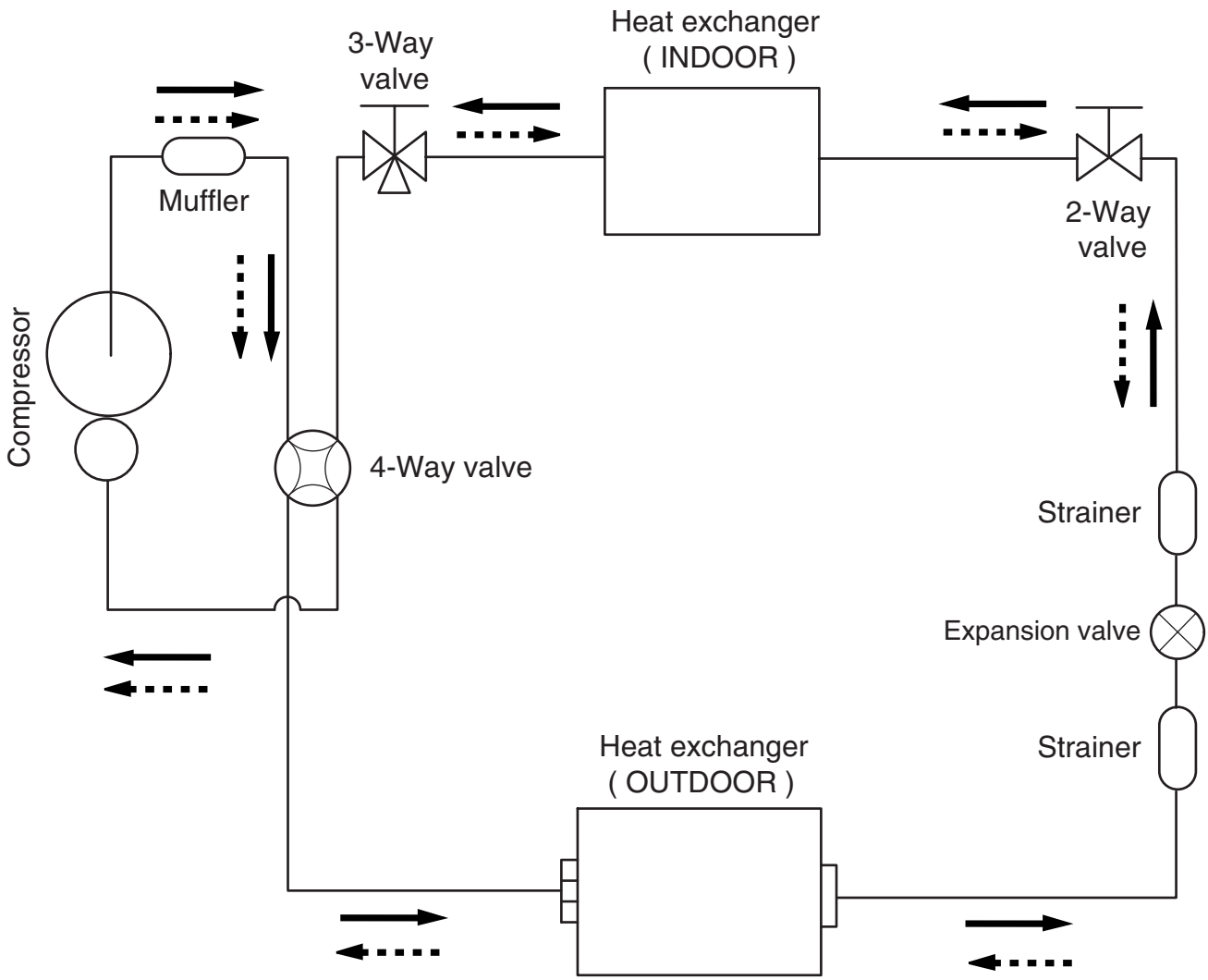

 Cooling  
 Heating

Refrigerant pipe diameter  
 Liquid : 1/4" (6.35 mm)  
 Gas : 3/8" (9.52 mm)



# INDOOR PCB CIRCUIT DIAGRAM

Models : ASYA07LCC, ASYA09LCC

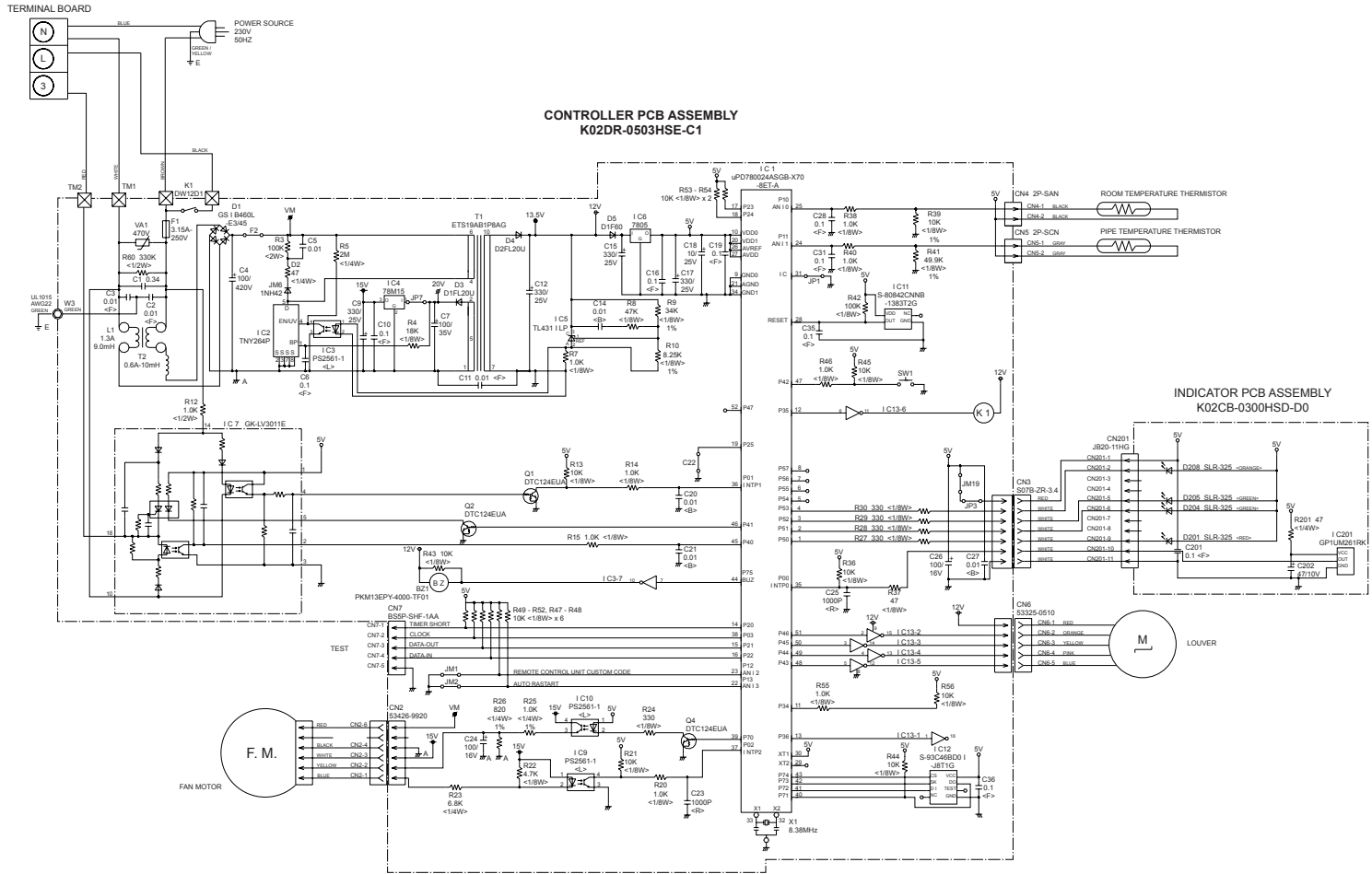

# OUTDOOR PCB CIRCUIT DIAGRAM

Models :  
 AOYR07LCC  
 AOYR09LCC

**INVERTER ASSEMBLY**  
 AOYR07LCC : EZ-00506HUE  
 AOYR09LCC : EZ-0053HUE

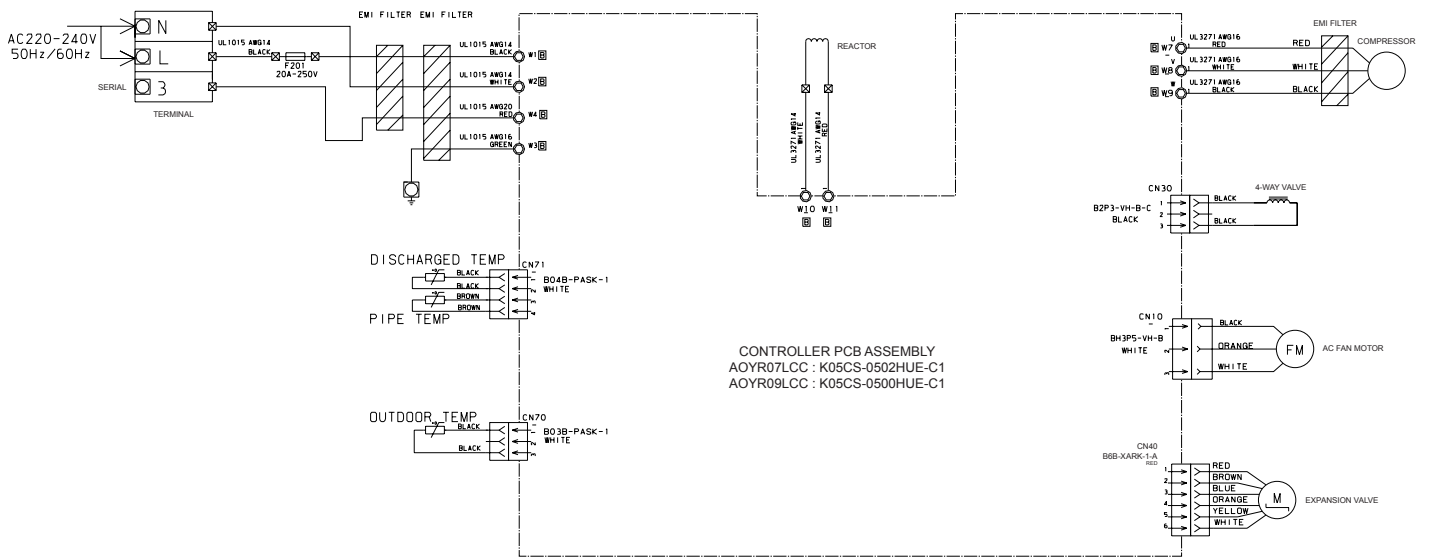

Models :  
AOYR07LCC  
AOYR09LCC

CONTROLLER PCB ASSEMBLY  
AOYR07LCC : K05CS-0502HUE-C1  
AOYR09LCC : K05CS-0500HUE-C1

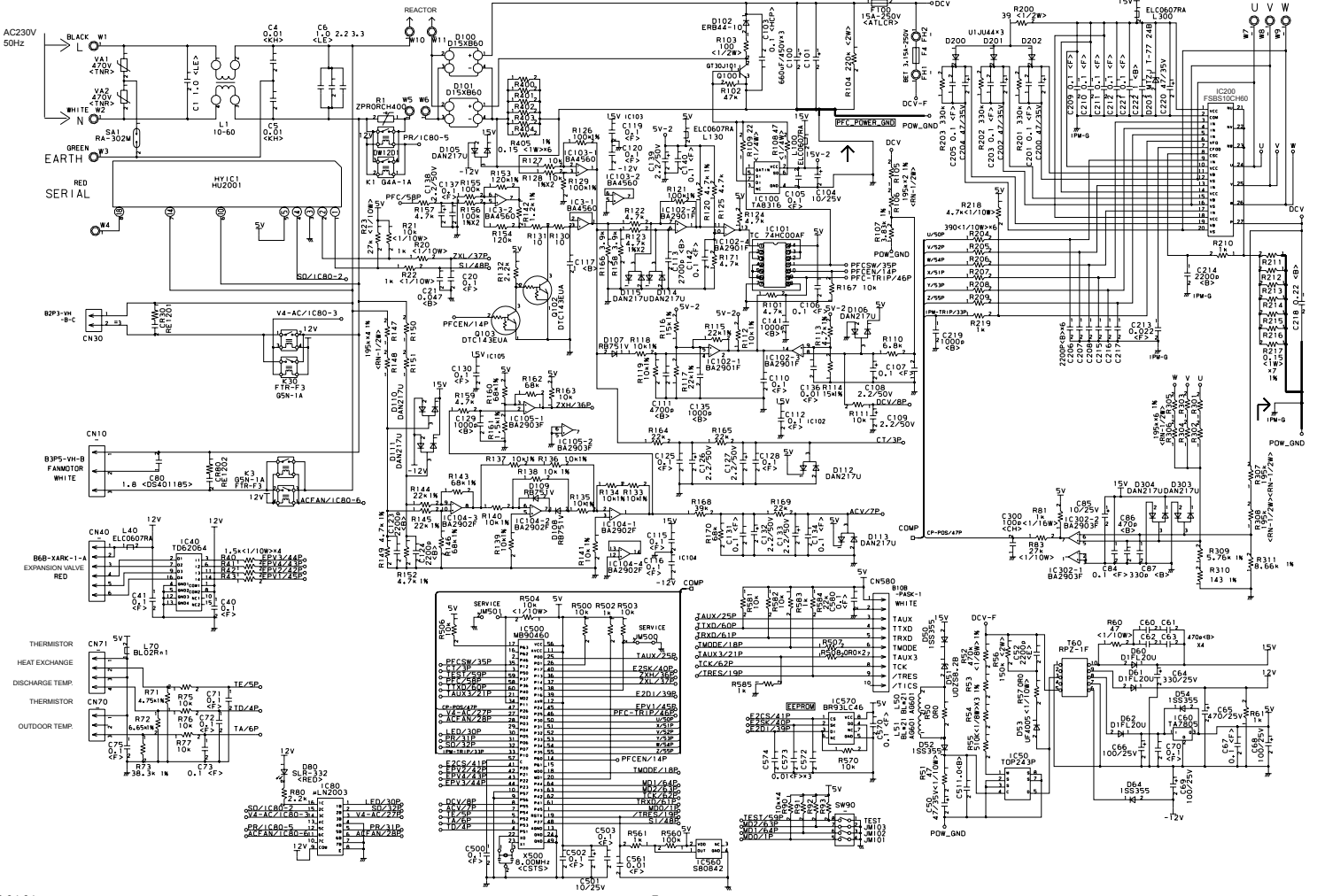



# ERROR CONTENTS

Models :  
 ASYA07LCC  
 ASYA09LCC

Error	Display		Error
	Operation LED	Timer LED	
Serial signal error	Off	2 flash	Serial signal (reverse) error, at operation start up
		3 flash	Serial signal (reverse) error, during operation
		4 flash	Serial signal (forward) error, at operation start up
		5 flash	Serial signal (forward) error, during operation
Indoor unit thermistor error	2 flash	2 flash	Indoor temperature thermistor open / short
		3 flash	Heat exchanger middle thermistor open / short
Outdoor unit thermistor error	3 flash	2 flash	Discharge thermistor open / short
		3 flash	Heat exchanger thermistor open
		4 flash	Outdoor temperature thermistor open / short
Indoor unit control error	4 flash	2 flash	Forced automatic SW welded
		3 flash	Main relay welded
		4 flash	Power interruption error
		7 flash	VDD permanent stop protection
Outdoor unit control error	5 flash	8 flash	reverse VDD permanent stop protection
		2 flash	Current trip error
		3 flash	CT abnormal
		5 flash	Compressor location detection error
Indoor fan motor error	6 flash	6 flash	Outdoor unit fan drive system abnormal
		2 flash	Abnormal lock
Refrigerant cycle error	7 flash	3 flash	Abnormal rotation
		2 flash	Discharge Temperature abnormal
Optional function error	8 flash	3 flash	Cooling high pressure abnormal rise
		4 flash	PFC circuit error
Model information error	0.1 sec on/off	0.1 sec on/off	Model information error

# DISASSEMBLY ILLUSTRATION

Models :  
ASYA07LCC  
ASYA09LCC

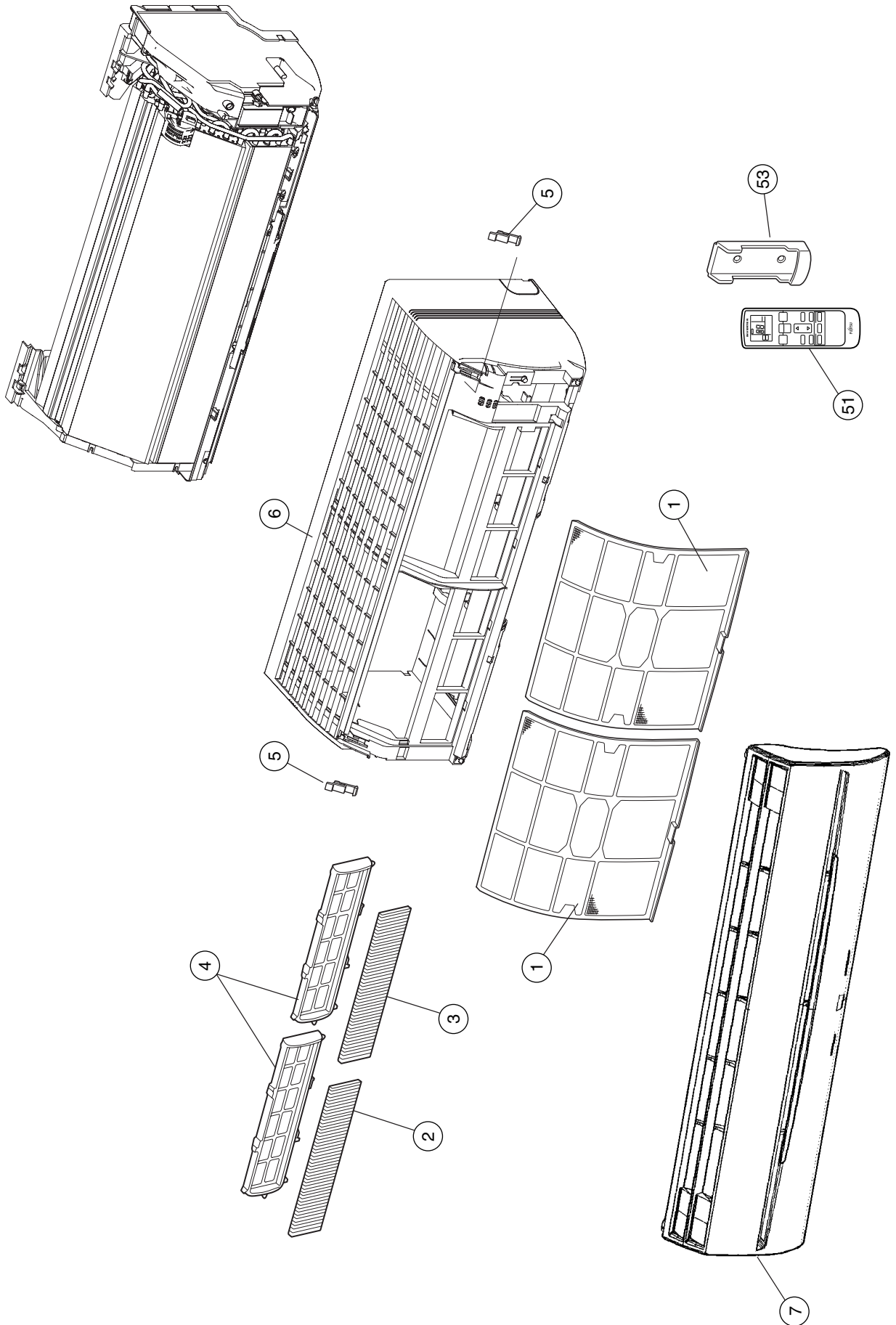

Models :  
ASYA07LCC  
ASYA09LCC

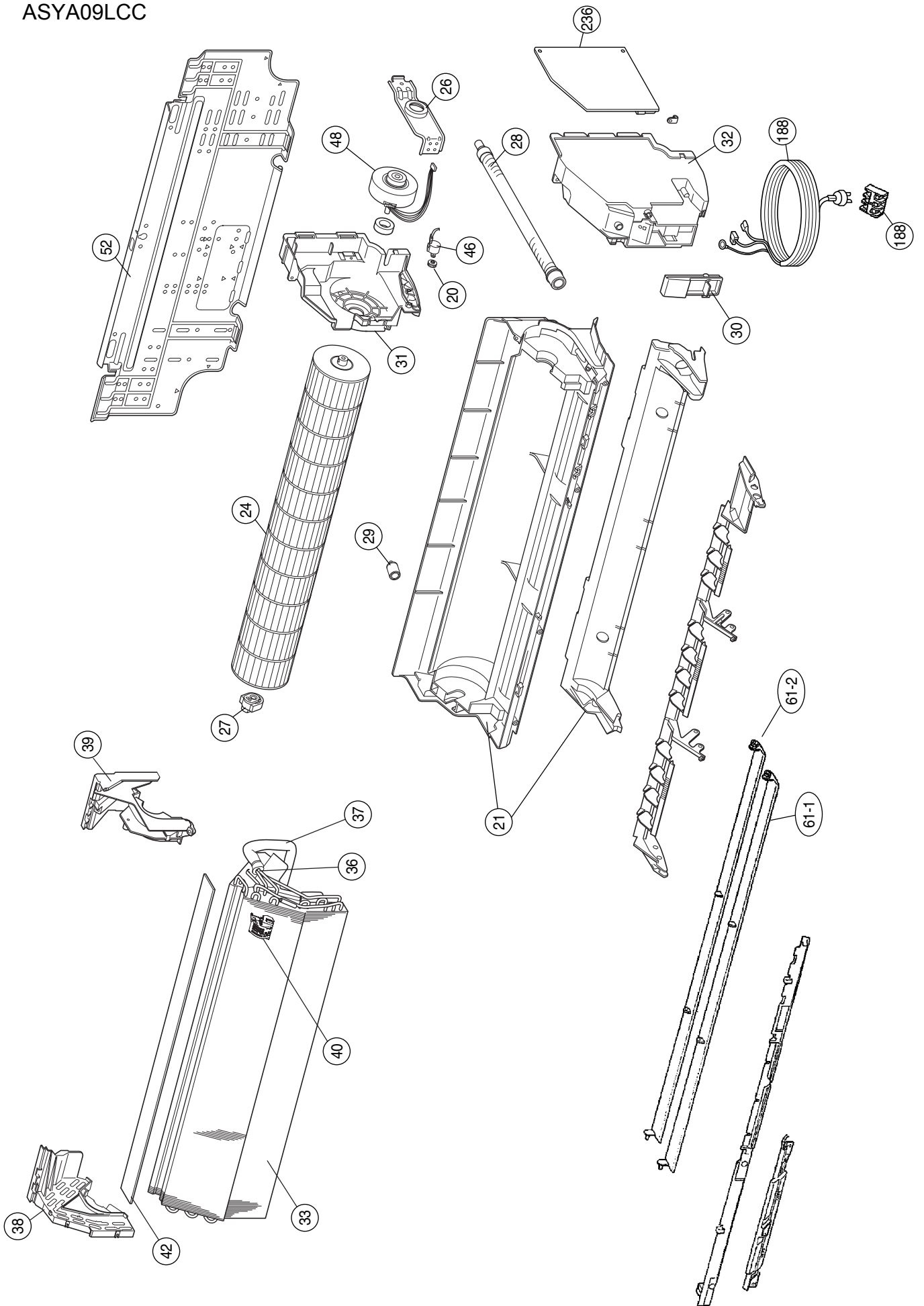

Models :  
AOYR07LCC  
AOYR09LCC

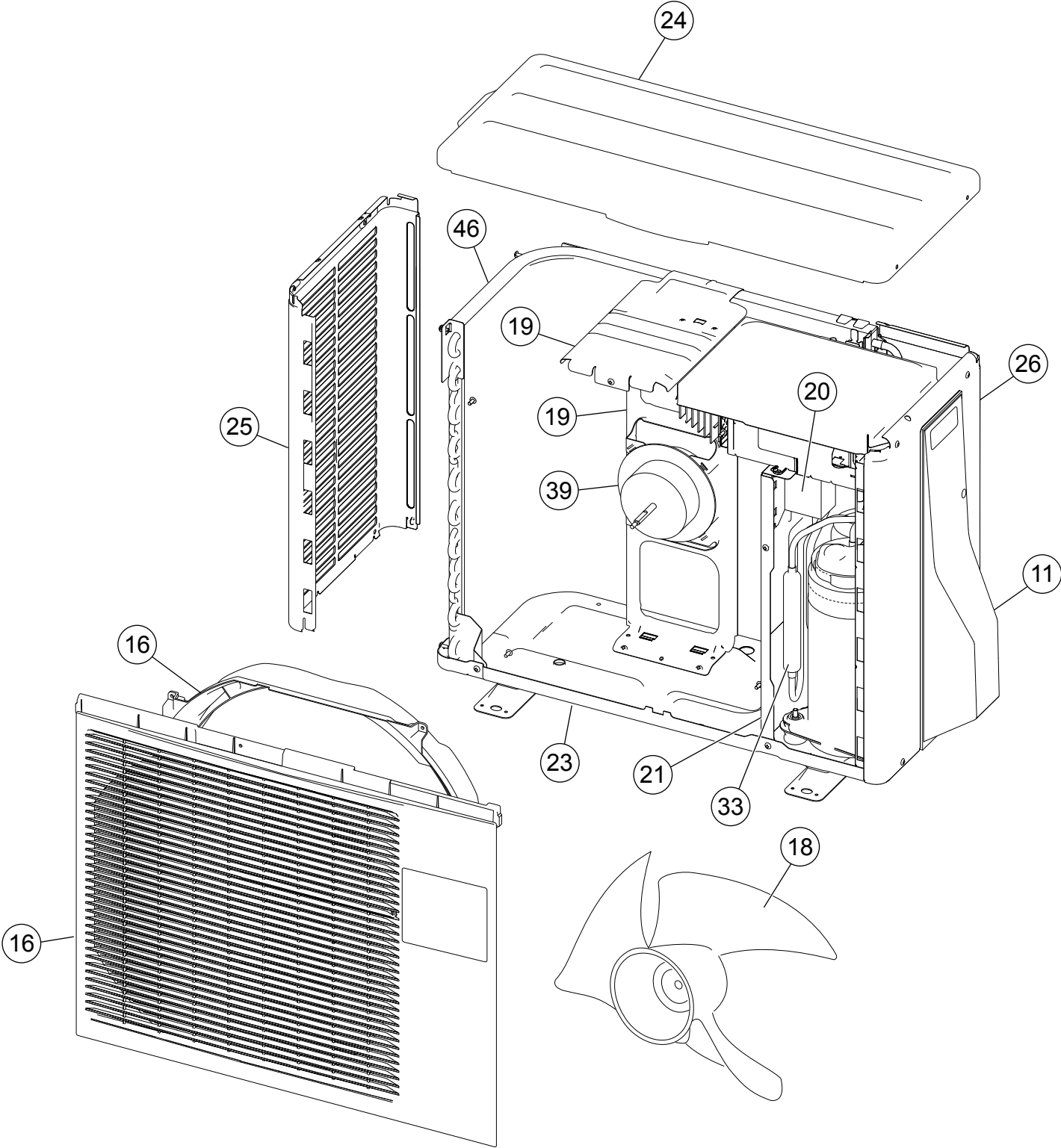

Models :  
AOYR07LCC  
AOYR09LCC

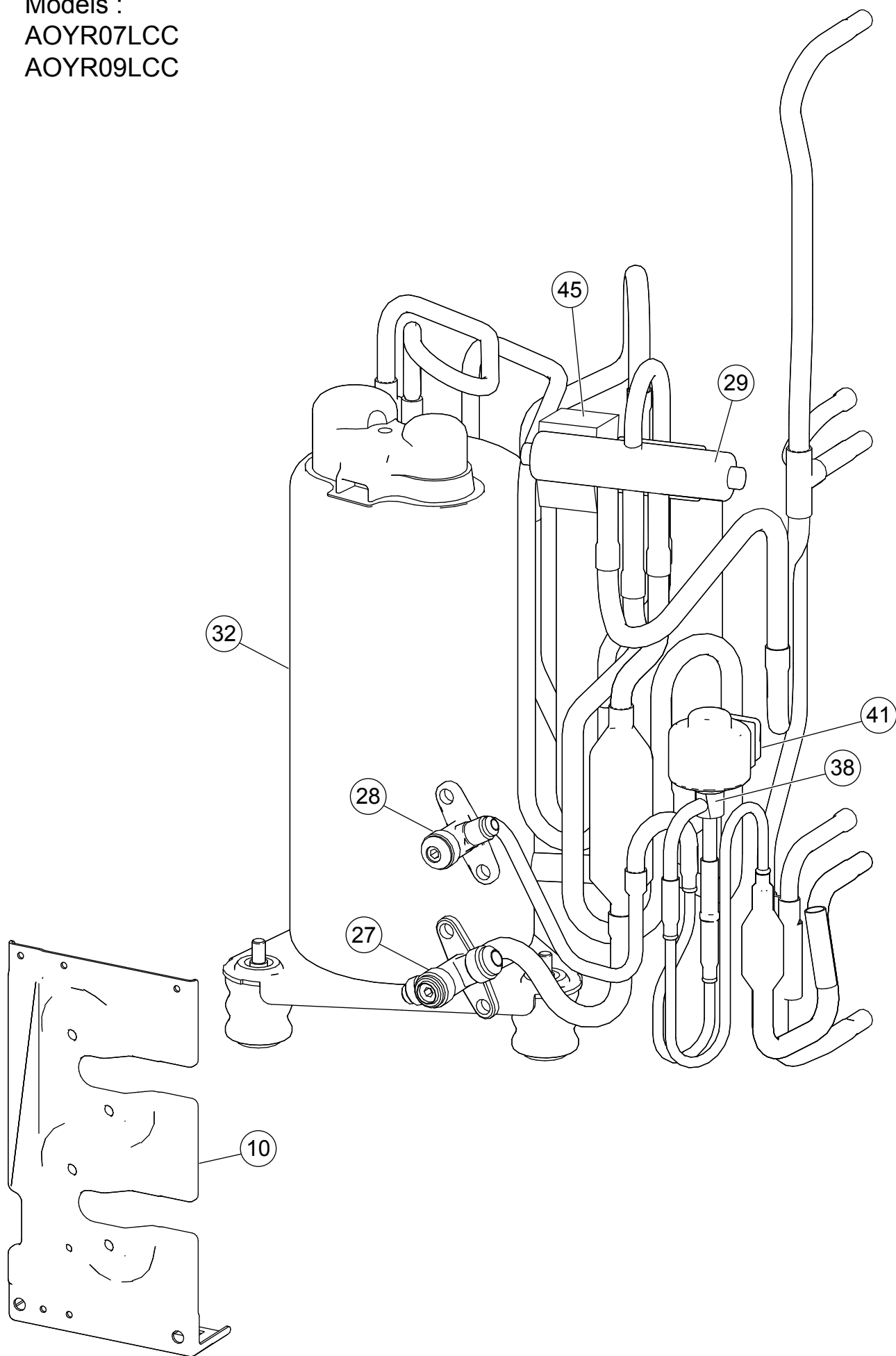

Models :  
AOYR07LCC  
AOYR09LCC

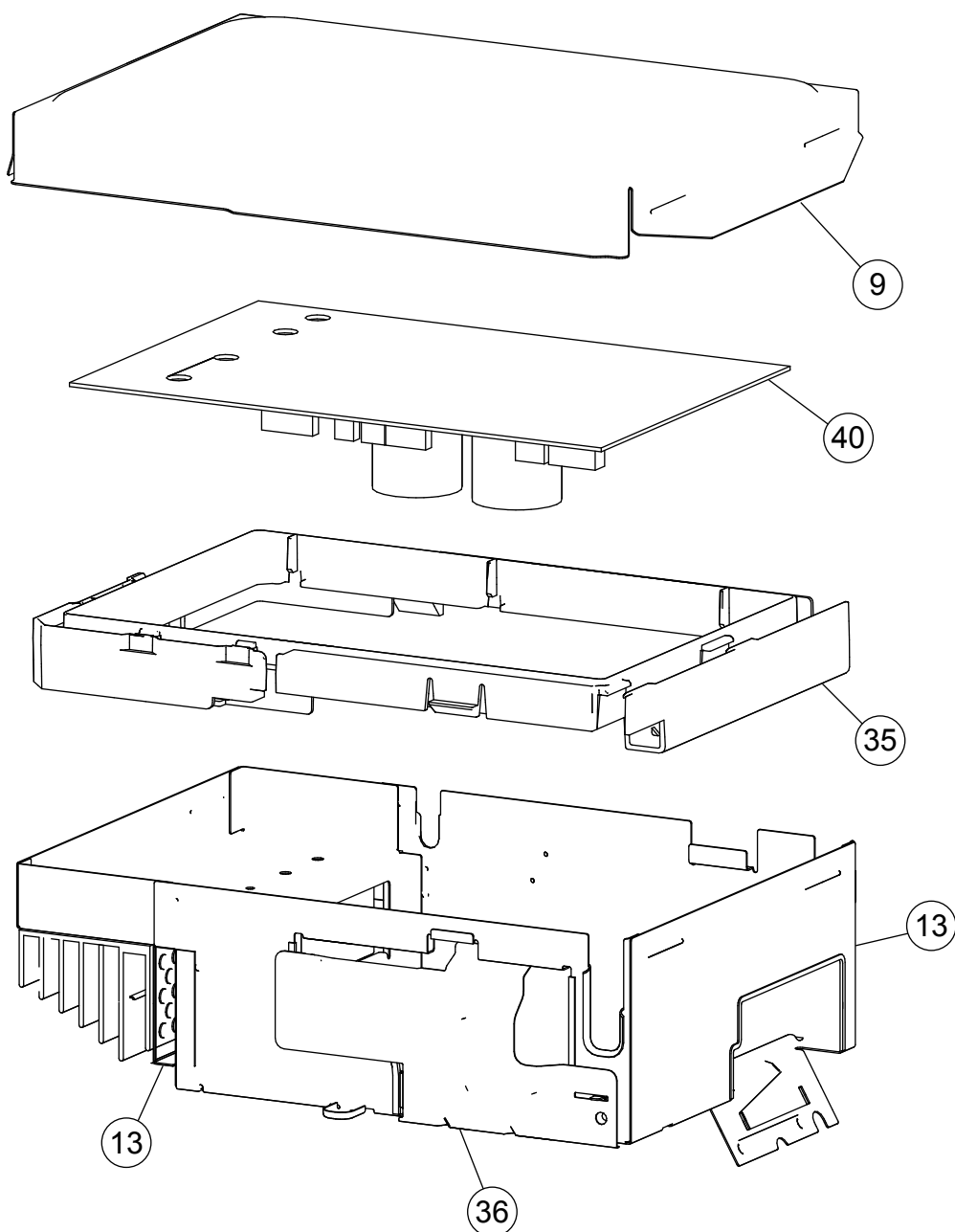

# PARTS LIST

## INDOOR UNIT





Ref. No.	Description	Part No.	Ord.
		ASYA07LCC ASYA09LCC	Q'ty
1	Air Filter	9309997011	
2	Filter (Electric)	9312153015	
3	Filter (ION)	9311925033	
4	Holder (Filter)	9306602017	
5	Clamper (Grille)	9306755010	
6	Front Panel Total Assy	9313130169	
7	Intake Grille Assy	9313131128	
20	Gear-A	9309994003	
21	Casing Assy	9311354079	
24	Crossflow Fan Assy	9307836015	
26	Clamp (Motor)	9310102008	
27	Shaft Holder-C Assy	9306628017	
28	Drain Hose Assy	9314147012	
29	Drain Cap Assy	9314493010	
30	Wire Clamper	9311946014	
31	Box (Switch)	9312908011	
32	Cover (Switch)	9312909018	
33	Evaporator Total Assy	9313099015	
36	Joint Pipe Assy	9313104016	
37	Insulation (Pipe)-E	9304607007	
38	Holder (Evaporator)-L	9309982017	
39	Holder (Evaporator)-R	9309983014	
40	Holder (Room Thermistor)	9311948018	
42	Air Seal	9310611005	
46	Step Motor	9900139025	
48	Fan Motor Assy	9601814016	
51	Remote Control Unit	9315027030	
52	Bracket Panel	9310001004	
53	Remote Control Unit Holder	9305642014	
61-1	Flow Control Panel-U	9309991033	
61-2	Flow Control Panel-Z	9309992030	
188	Power Cord Assy (Power Cord+Terminal)	9900339036	
236	Controller PCB Assy	9705656109 (K02DR-0503HSE-C1)	
---	Pipe Temperature Thermistor	9702039042	
---	Room Temperature Thermistor	9700801108	
---	Indicator PCB Assy	9705039032	

## OUTDOOR UNIT

Ref. No.	Description	Part No.	Ord. Q'ty
		AOYR07LCC AOYR09LCC	
9	Cover (Case)	9331256018	
10	Bracket Valve	9310229026	
11	Cover (Switch)	9310979013	
13	Inverter Case Assy	9331279017	
16	Front Panel Assy	9331334013	
18	Propeller Fan	9309909014	
19	Bracket (Motor) Assy	9331355018	
20	Reactor Assy	9900357016	
21	Separator Assy	9331392013	
23	Base Assy	9331280013	
24	Top Panel Assy	9331332019	
25	Cabinet Left Assy	9313991036	
26	Cabinet Right Assy	9331336017	
27	3-Way Valve Assy	9331303019	
28	2-Way Valve Assy	9331301015	
29	4-Way Valve Assy	9331305013	
32	Compressor Assy	9315206015	
33	Muffler	9308660015	
35	PCB Holder	9331261012	
36	Cover (Inverter Case)	9331258012	
38	Pulse Motor Valve Assy	9331317016	
39	Motor	9602117017	
40	Inverter PCB Assy (07)	9707078039	
40	Inverter PCB Assy (09)	9707078015	
41	Expansion Valve Coil	9900057039	
45	Solenoid	9970055010	
46	Condenser Assy	9331291019	
---	Fuse Holder	0501454012	
---	Fuse	0600382018	
---	Thermister Holder Pipe	313714262805	
---	Thermistor Spring-A	313728262708	
---	Thermistor Spring	9300089012	
---	Terminal	9306489038	
---	Cord Clamp	9307271014	
---	Rubber Cushion	9312680016	
---	Nut Special Assy	9313452018	
---	Protective Net	9331262019	
---	Thermistor Assy	9900148034	
---	Thermistor (Outdoor Temp)	9900210038	
---	Emblem Rear	9315210012	

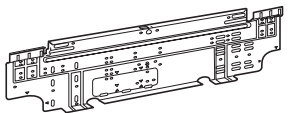

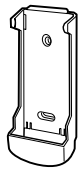
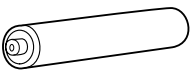
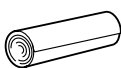
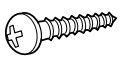
## STANDARD ACCESSORIES

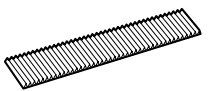
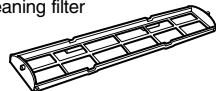
Name and Shape	Part No.
	ASYA07LCC ASYA09LCC
Wall hook bracket 	9312752027
Remote control unit 	9315027030
Remote control unit holder 	9305642045
Battery (penlight) 	0600185527
Cloth tape 	9310519004
Tapping screw (big) (φ 4 x 25) 	0700076046
Tapping screw (small) (φ 3 x 12) 	0700019036
Air cleaning filter 	9312153015
	9311925033
Air cleaning filter frame 	9306602017

0601G3014