

**SPLIT TYPE
ROOM AIR CONDITIONER
CEILING type (50Hz)**

**SERVICE
MANUAL**

Models

Indoor unit

Outdoor unit

ABY30FBAG

AOY30FNBWL

ABY30UBAG

AOY30UNBWL



CONTENTS

SPECIFICATIONS	1
OUTLINE AND DIMENSIONS	2
REFRIGERANT SYSTEM DIAGRAM	4
CIRCUIT DIAGRAM	5
INDOOR PCB CIRCUIT DIAGRAM	7
OUTDOOR PCB CIRCUIT DIAGRAM	9
ERROR DISPLAY	10
DISASSEMBLY ILLUSTRATION	11
PARTS LIST	21

SPECIFICATIONS

TYPE		COOLING	COOLING & HEATING
INDOOR UNIT		ABY30FBAG	ABY30UBAG
OUTDOOR UNIT		AOY30FNBWL	AOY30UNBWL
COOLING CAPACITY	(kW)	8.40	8.40
HEATING CAPACITY	(kW)	----	9.50

ELECTRICAL DATA

POWER SOURCE	(V)	230	
FREQUENCY		1ø 50Hz	
RUNNING CURRENT	(A)	COOLING	13.6
		HEATING	----
INPUT WATTS	(kW)	COOLING	2.95
		HEATING	----
E.E.R.	(kW/kW)	COOLING	2.85
		HEATING	----
MOISTURE REMOVAL	(ℓ /hr)	3.0	
AIR CIRCULATION	(m ³ /hr)	1,450	

COMPRESSOR

TYPE	Hermetic type, 2 poles, Induced by condenser, Rotary
DISCRIMINATION	5JS330DAE01

FAN MOTOR

POWER SOURCE	(V)	230	
INDOOR UNIT	DISCRIMINATION	MFA-45DZM	
	HI-SPEED	(r.p.m.)	850
	MED-SPEED	(r.p.m.)	750
	LO-SPEED	(r.p.m.)	600
OUTDOOR UNIT	DISCRIMINATION	MFB-30PTT	
	HI-SPEED	(r.p.m.)	780
	LO-SPEED	(r.p.m.)	400

DIMENSIONS

INDOOR UNIT	H x W x D (mm)	240 x 1,660 x 700
OUTDOOR UNIT	H x W x D (mm)	830 x 900 x 330

WEIGHT

INDOOR UNIT	NET / GROSS (kg)	48 / 61	
OUTDOOR UNIT	NET / GROSS (kg)	68 / 74	69 / 75

ADDITIONAL REFRIGERANT CHARGE (R410A)

FULL CHARGE AMOUNT	Pipe Length	7.5 m (25 ft)	2,300 g (81.1 oz)	2,300 g (81.1 oz)
		10.0 m (33 ft)	2,350 g (82.9 oz)	2,400 g (84.7 oz)
		20.0 m (66 ft)	2,550 g (89.9 oz)	2,800 g (98.8 oz)
		30.0 m (99 ft)	2,750 g (97.0 oz)	3,200 g (112.9 oz)
ADDITIONAL CHARGE			20 g / m (0.21 oz/ft)	40 g / m (0.43 oz/ft)

OUTLINE AND DIMENSIONS

(Unit : mm)

INDOOR UNIT

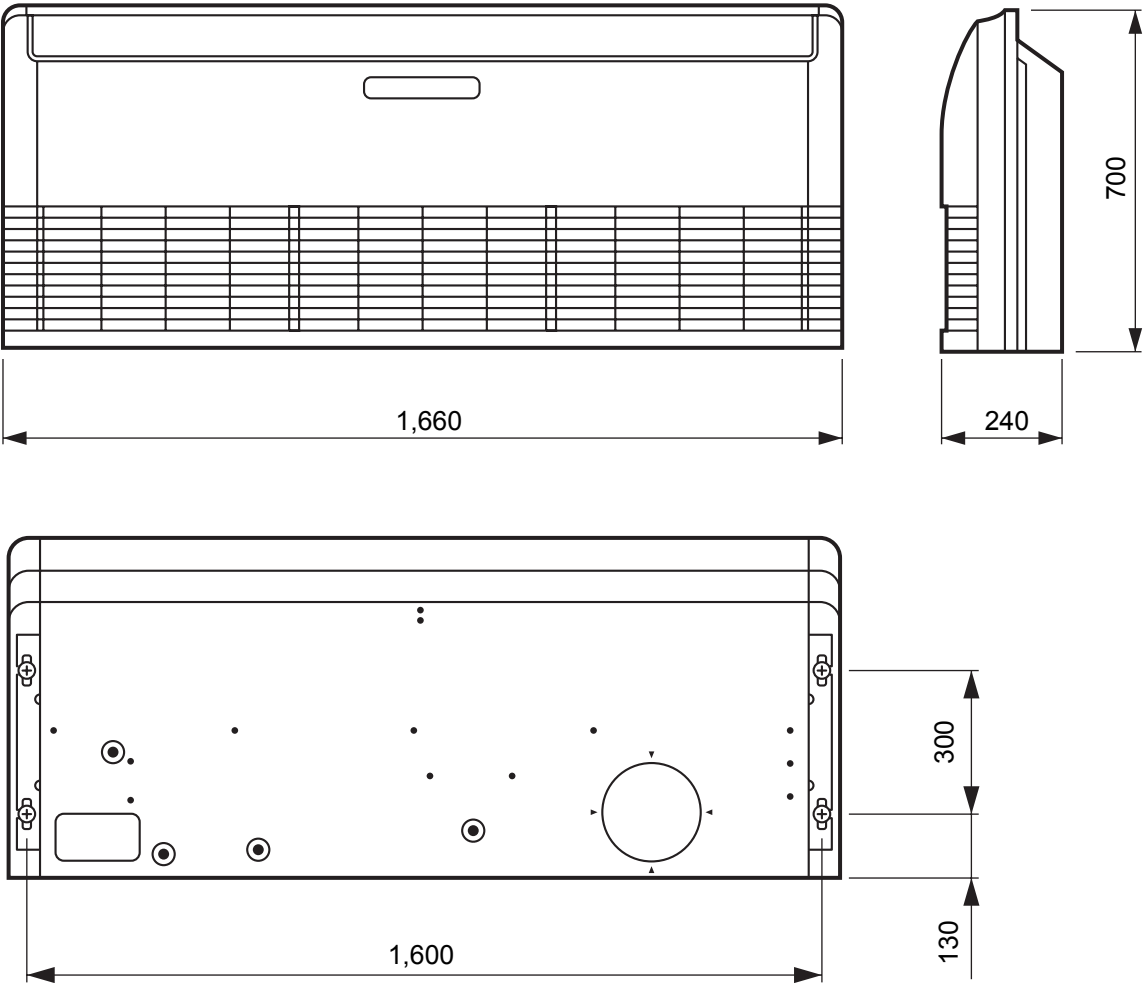

OUTDOOR UNIT

(Unit : mm)

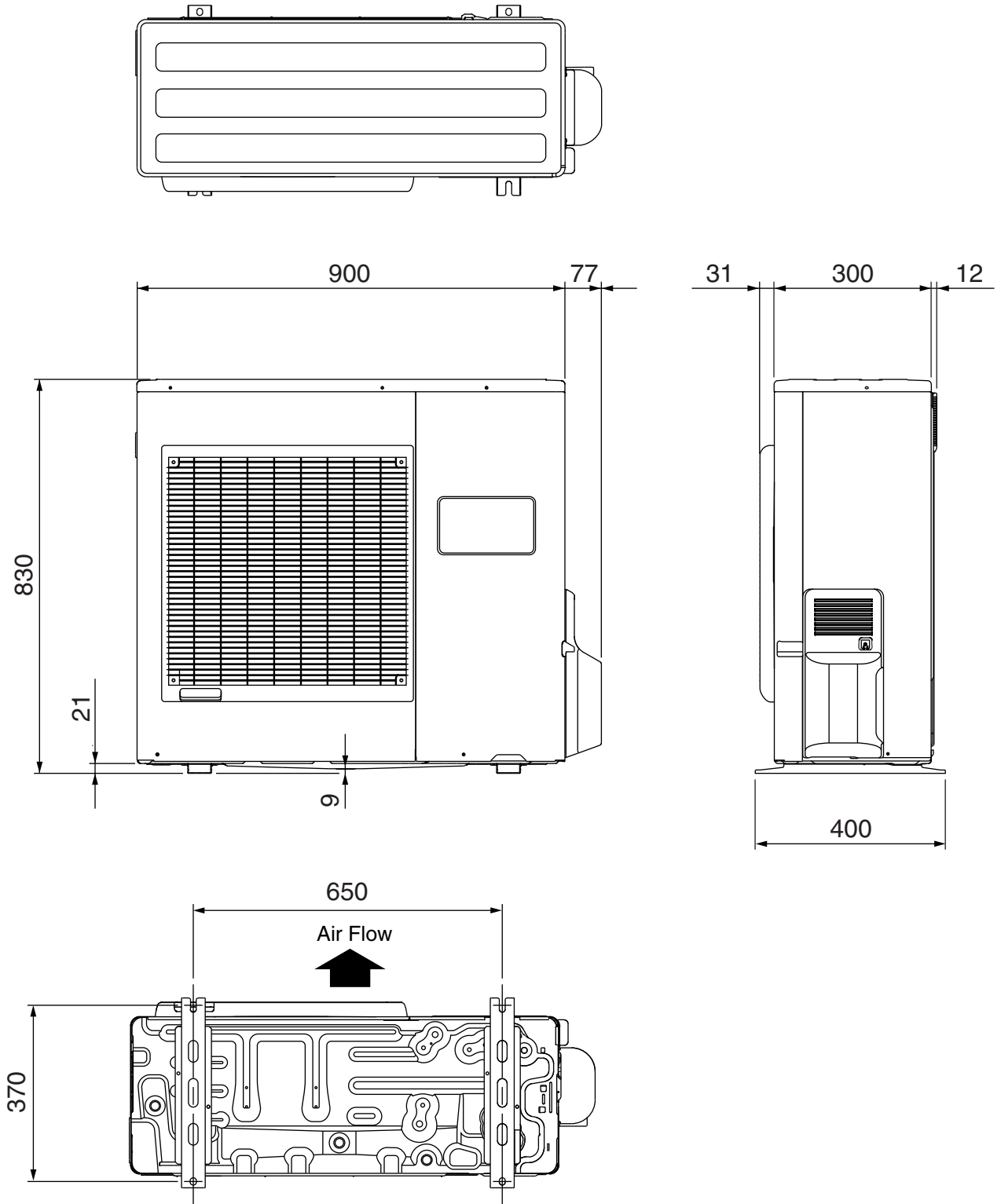

REFRIGERANT SYSTEM DIAGRAM

Models : ABY30FBAG / AOY30FNBWL

OUTDOOR UNIT

INDOOR UNIT

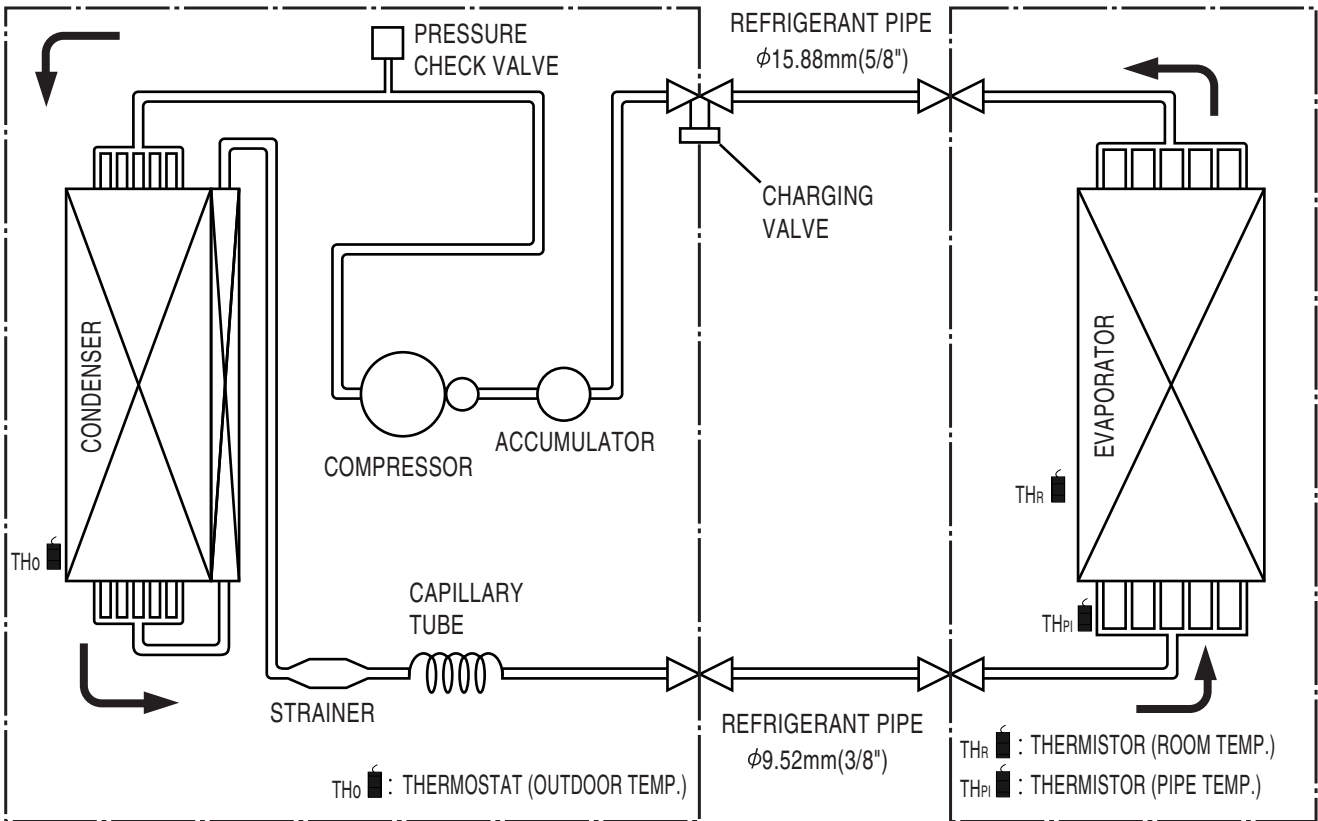

Models : ABY30UBAG / AOY30UNBWL

OUTDOOR UNIT

INDOOR UNIT

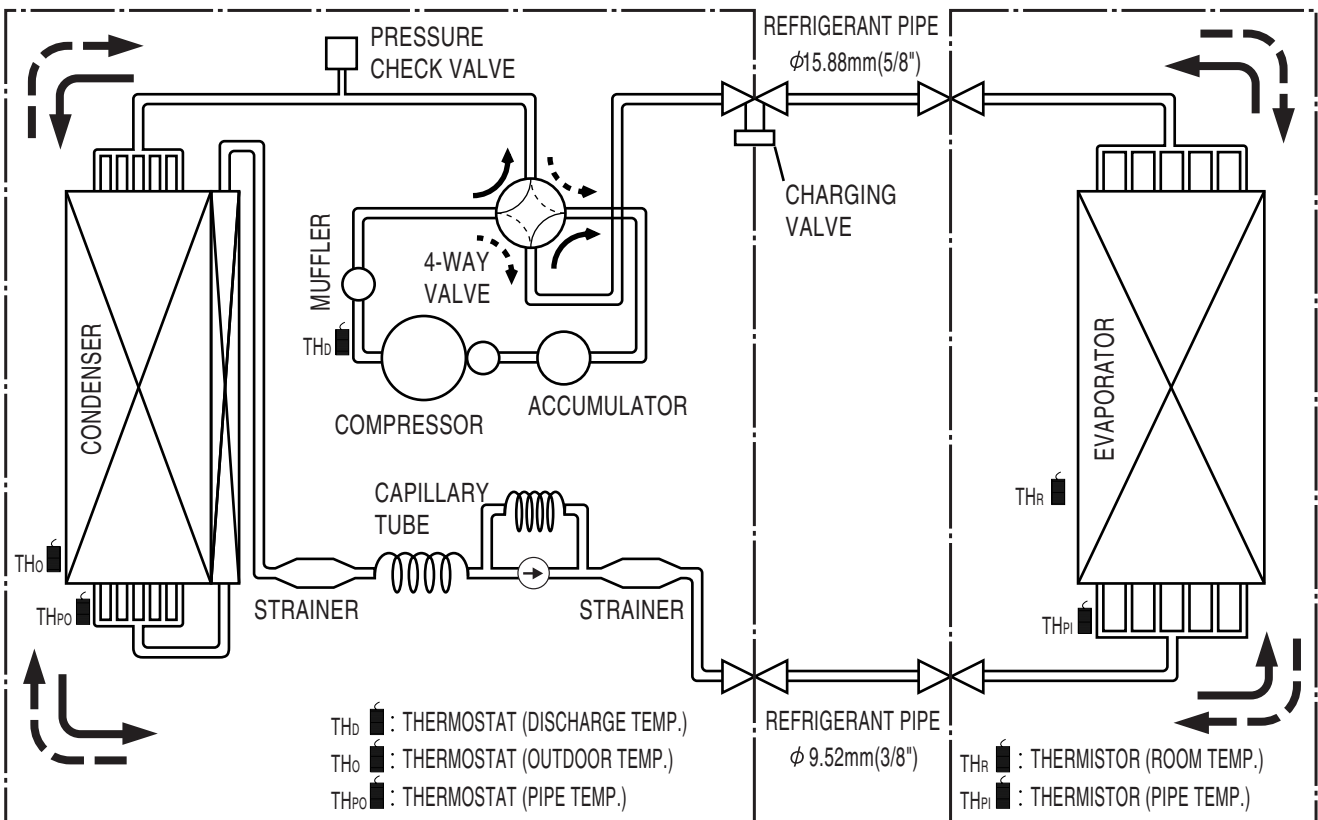

→ : COOL
 - - - → : HEAT

CIRCUIT DIAGRAM

Models : ABY30FBAG / AOY30FNBWL

INDOOR UNIT

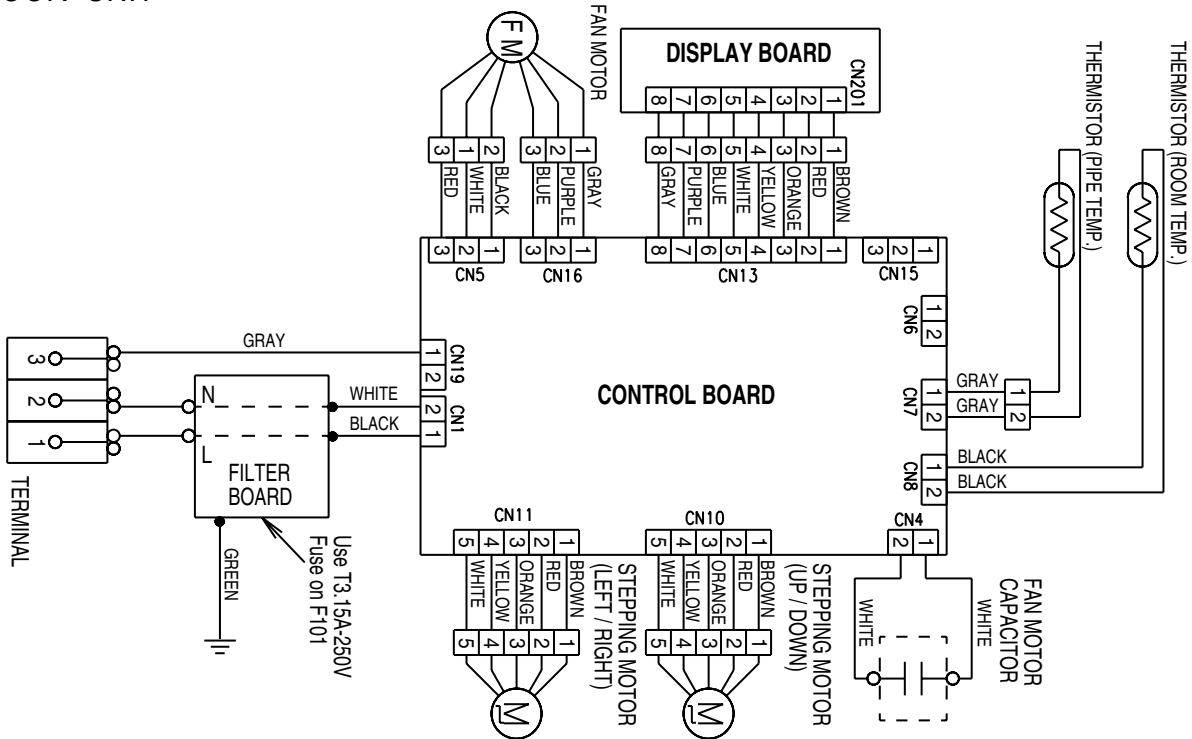

OUTDOOR UNIT

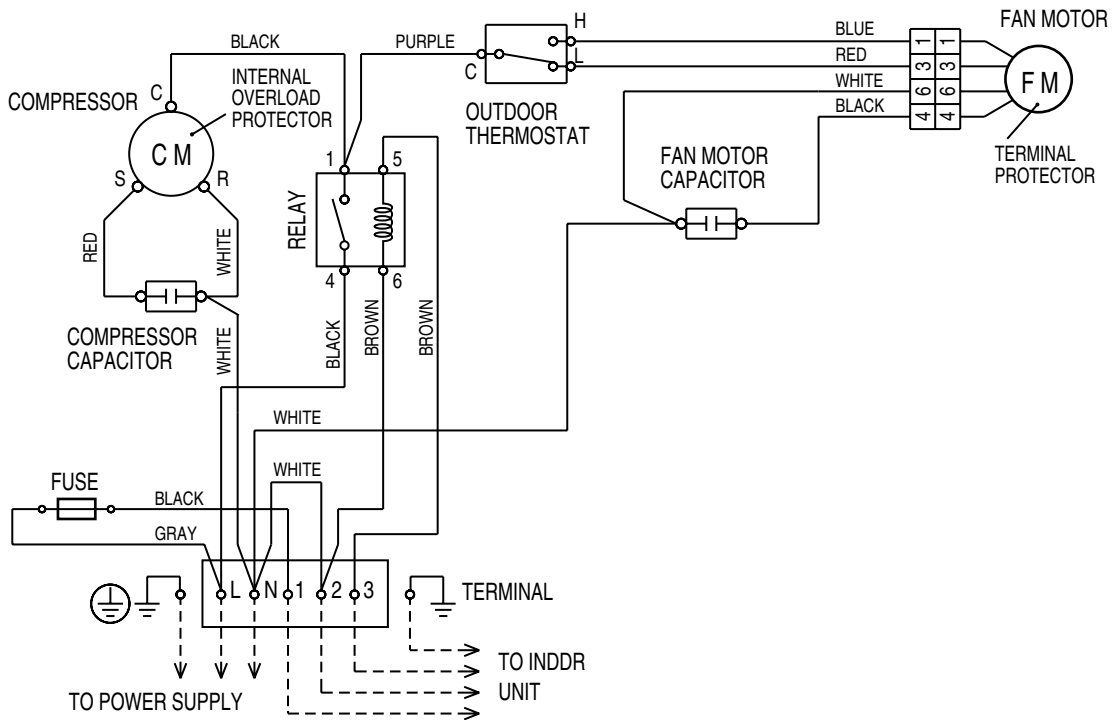

INDOOR UNIT

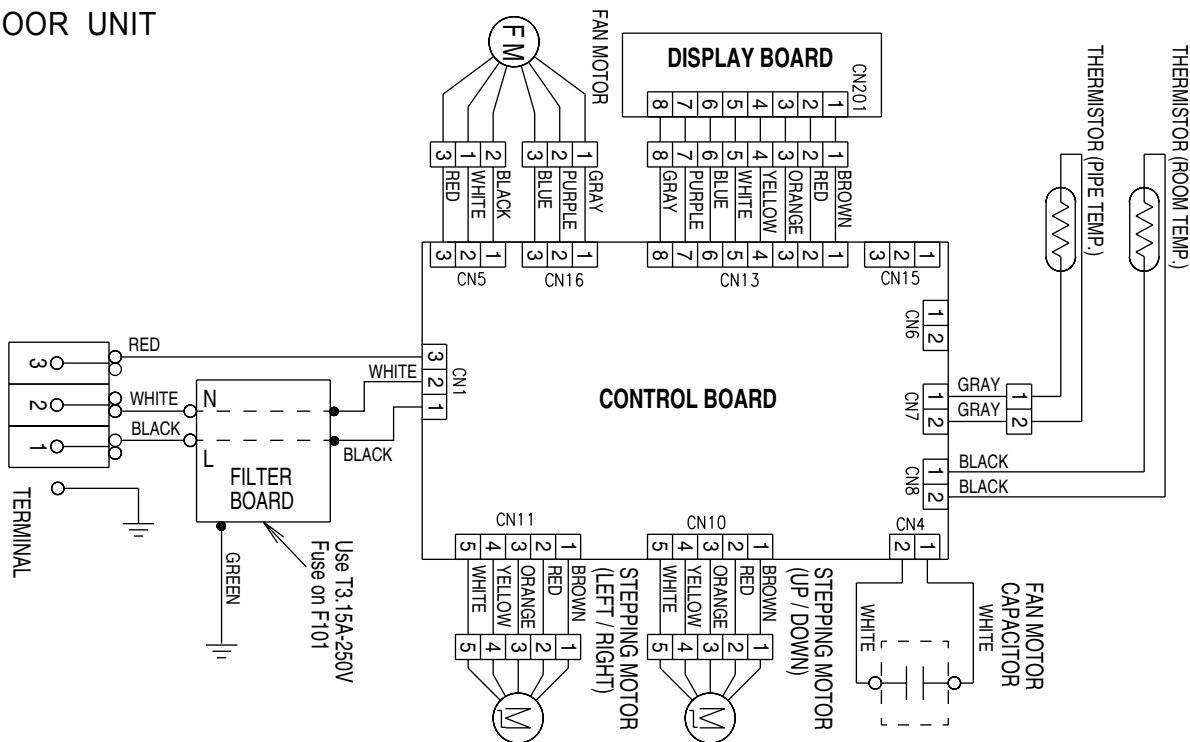

OUTDOOR UNIT

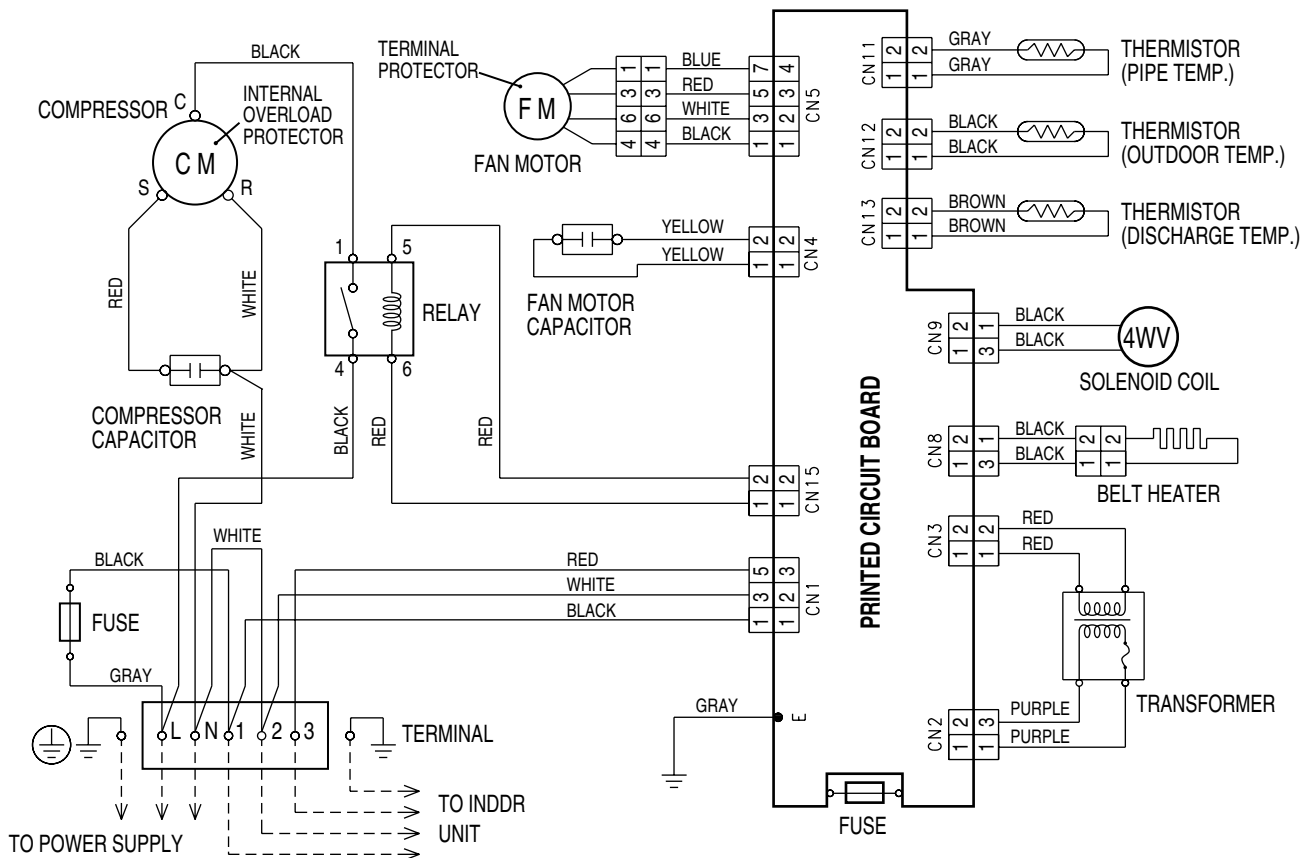

INDOOR PCB CIRCUIT DIAGRAM

CONTROLLER PCB ASSEMBLY (MAIN PCB) EZ-0020FW5-C

Model : ABY30FBAG

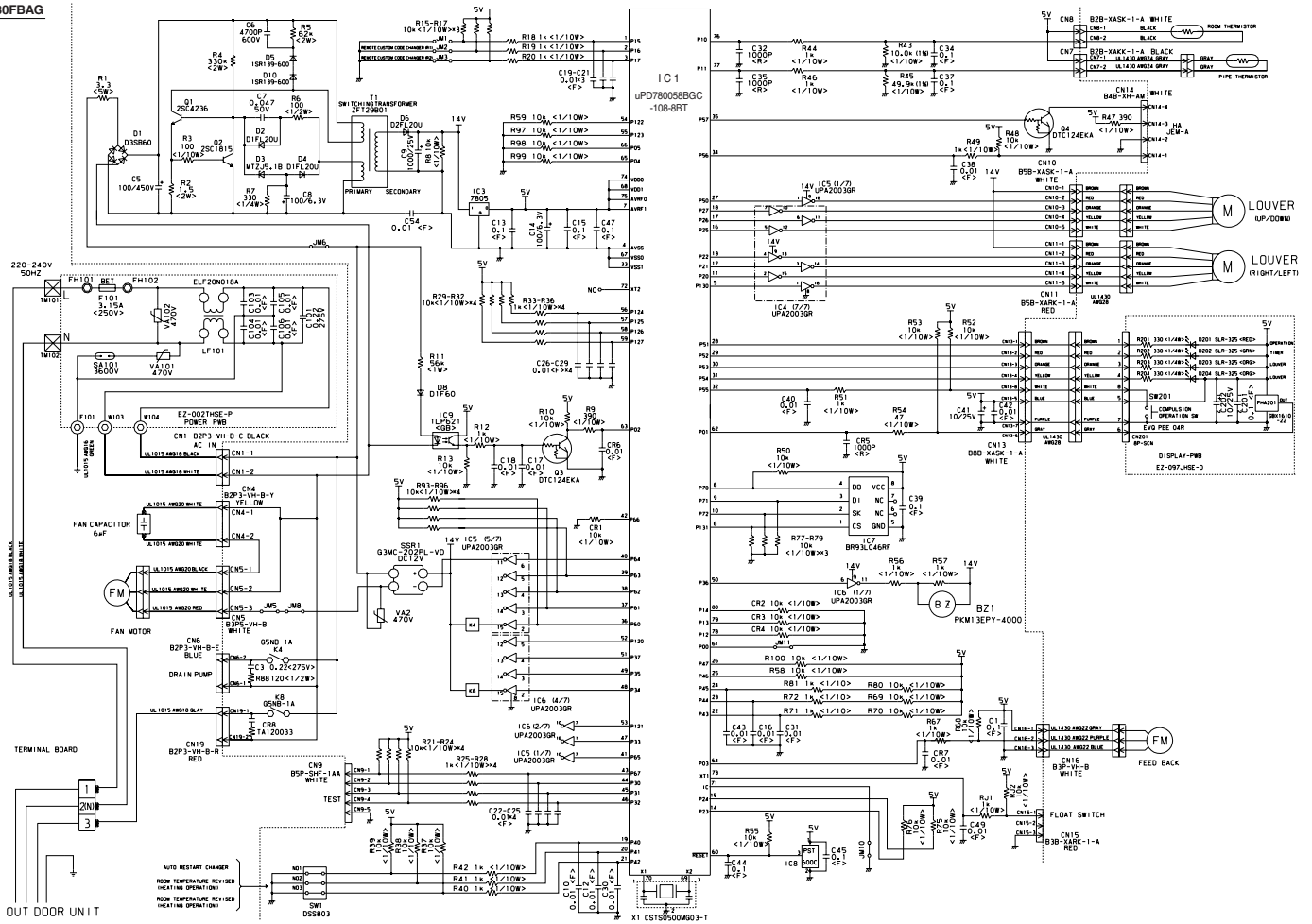

Model : ABY30UBAG

CONTROLLER PCB ASSEMBLY (MAIN PCB)

EZ-0027HSE-C

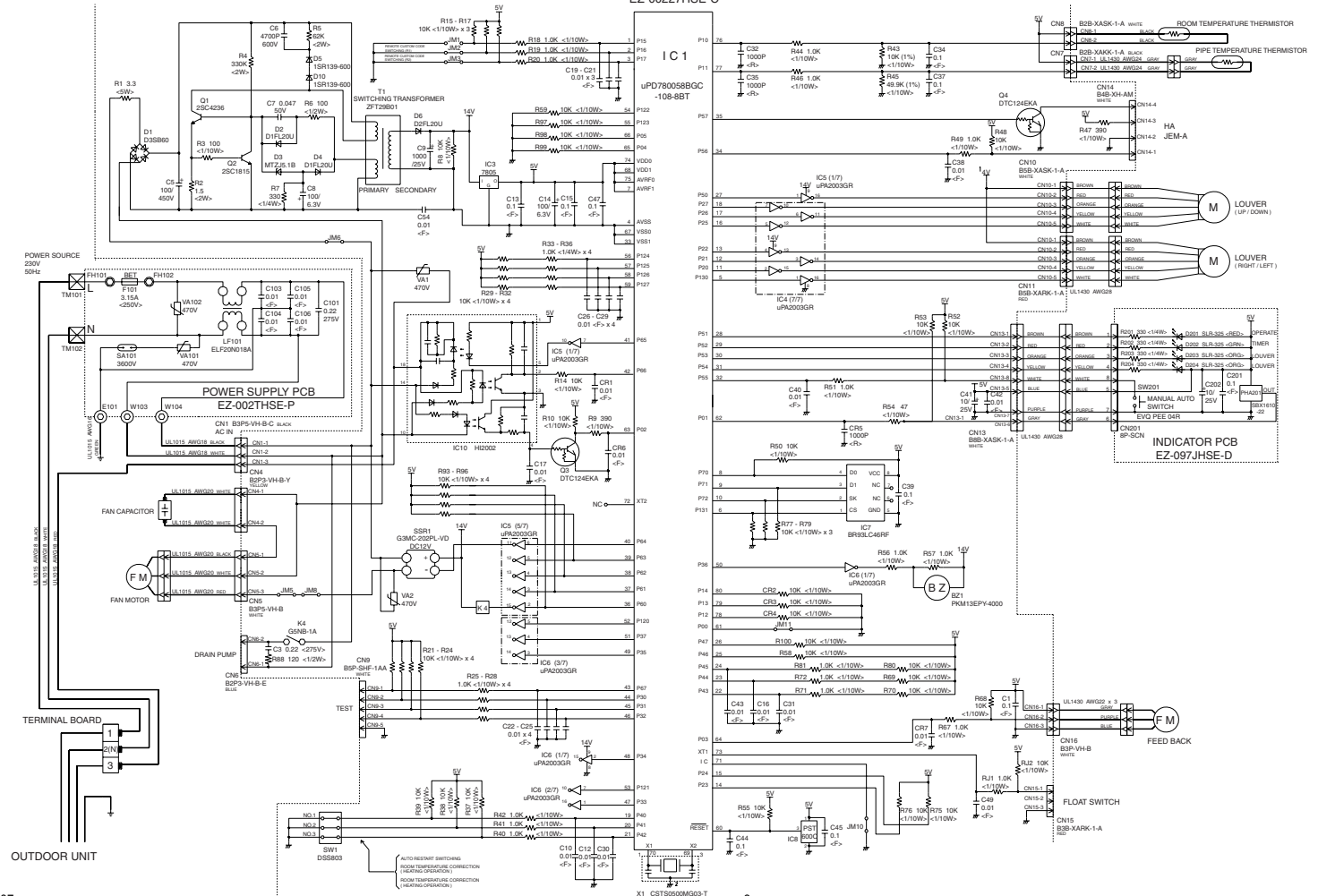

OUTDOOR PCB CIRCUIT DIAGRAM

CONTROLLER PCB ASSEMBLY (MAIN PCB)

Model : AOY30UNBWL

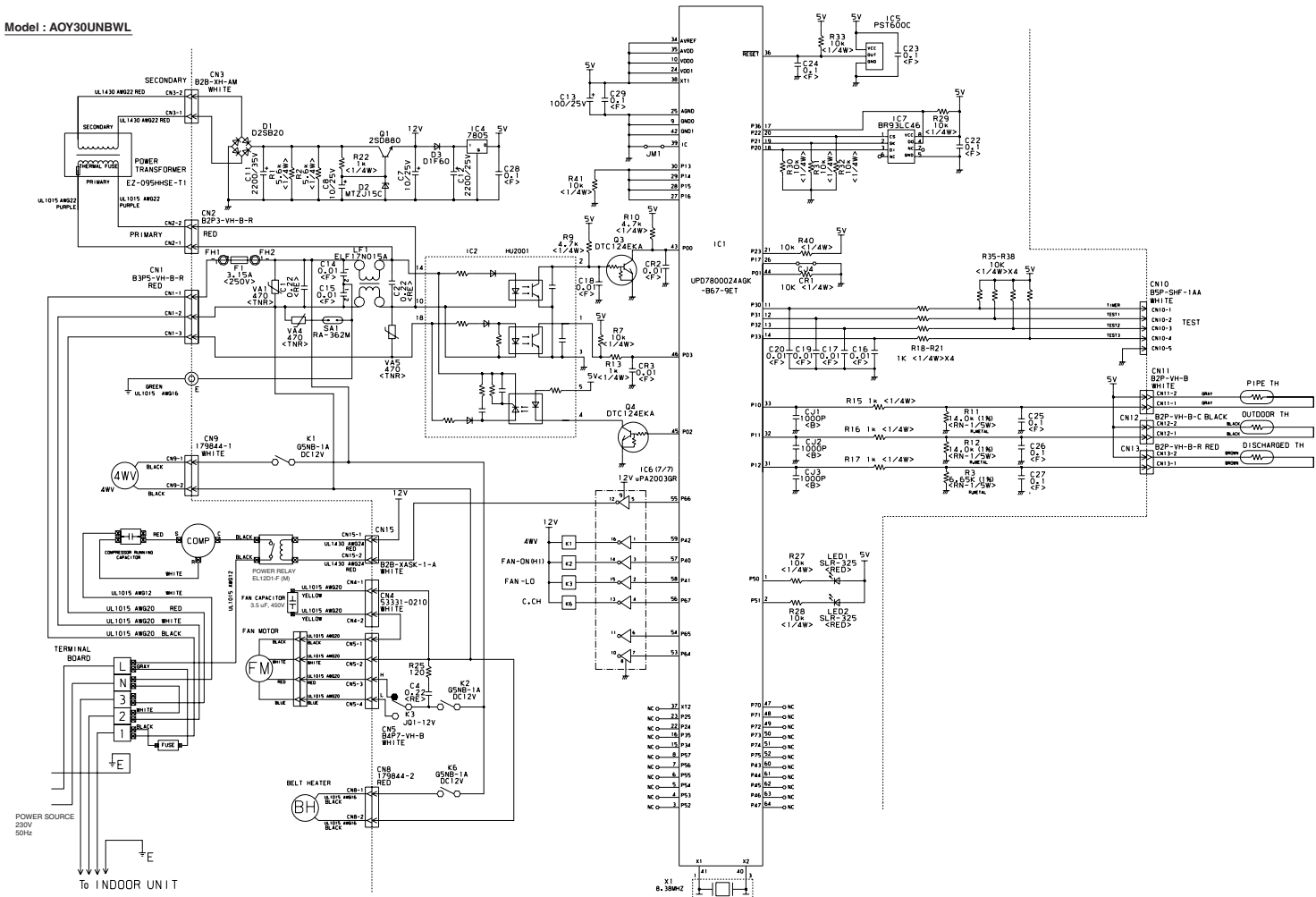

ERROR DISPLAY

1. INDOOR UNIT

Operation can be checked by lighting and flashing of the display section OPERATION, TIMER, and VERTICAL SWING lamps.

Perform judgment in accordance with the following.

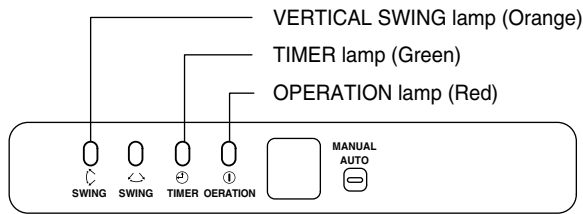

TEST RUNNING

When the air conditioner is run by pressing the remote control unit test run button, the OPERATION, TIMER, and VERTICAL SWING lamps flash slowly at the same time.

ERROR

The OPERATION, TIMER, and VERTICAL SWING lamps operate as follows (Table 1) according to the error contents.

OPERATION lamp (RED)	TIMER lamp (GREEN)	SWING lamp (ORANGE)	Error contents
○	○	×	Indoor EEPROM abnormal
○	○	○	Outdoor EEPROM abnormal
(2 times) ●	○	×	Indoor room temperature sensor open
(2 times) ●	○	○	Indoor room temperature sensor shortcircuited
(3 times) ●	○	×	Indoor heat exchanger temperature sensor open
(3 times) ●	○	○	Indoor heat exchanger temperature sensor shortcircuited
(4 times) ●	○	×	Float switch operated
(5 times) ●	○	×	Indoor signal abnormal
(5 times) ●	○	○	Outdoor signal abnormal
(6 times) ●	○	×	Indoor fan abnormal
○	(2 times) ●	×	Outdoor power source connection abnormal
○	(3 times) ●	×	Outdoor heat exchanger temperature sensor open
○	(3 times) ●	○	Outdoor heat exchanger temperature sensor shortcircuited
○	(4 times) ●	×	Outdoor temperature sensor open
○	(4 times) ●	○	Outdoor temperature sensor shortcircuited
○	(5 times) ●	×	Outdoor discharge pipe temperature sensor open
○	(5 times) ●	○	Outdoor discharge pipe temperature sensor shortcircuited
○	(6 times) ●	×	Outdoor high pressure abnormal
○	(7 times) ●	×	Outdoor discharge pipe temperature abnormal

○ : 0.1s ON/0.1s OFF (flash) × : OFF

● : 0.5s ON/0.5s OFF (flash)

2. OUTDOOR UNIT

ERROR : Heat & Cool model (Reverse cycle) only

When a malfunction occurs in the outdoor unit, the LEDs on the circuit board light to indicate the error. Refer to the following table for the description of each error according to the LEDs.

Error display		Error contents
LED1	LED2	
		Model abnormal or EEPROM abnormal
		Power source connection error
		Discharge temperature sensor error
		Outdoor heat exchanger temperature sensor error
		Outdoor temperature sensor error
		Communication signal error
		Indoor unit error
		Discharge temperature abnormal
		High pressure abnormal
		Discharge temperature abnormal (24h)
		High pressure abnormal (24h)

When the fault is cleared, the LED lamp goes off.

However, for discharge pipe temperature abnormal and high pressure abnormal, the LED lamp lights continuously for 24 hours, as long as the power is not turned off.

DISASSEMBLY ILLUSTRATION

INDOOR UNIT

Models : ABY30FBAG
ABY30UBAG

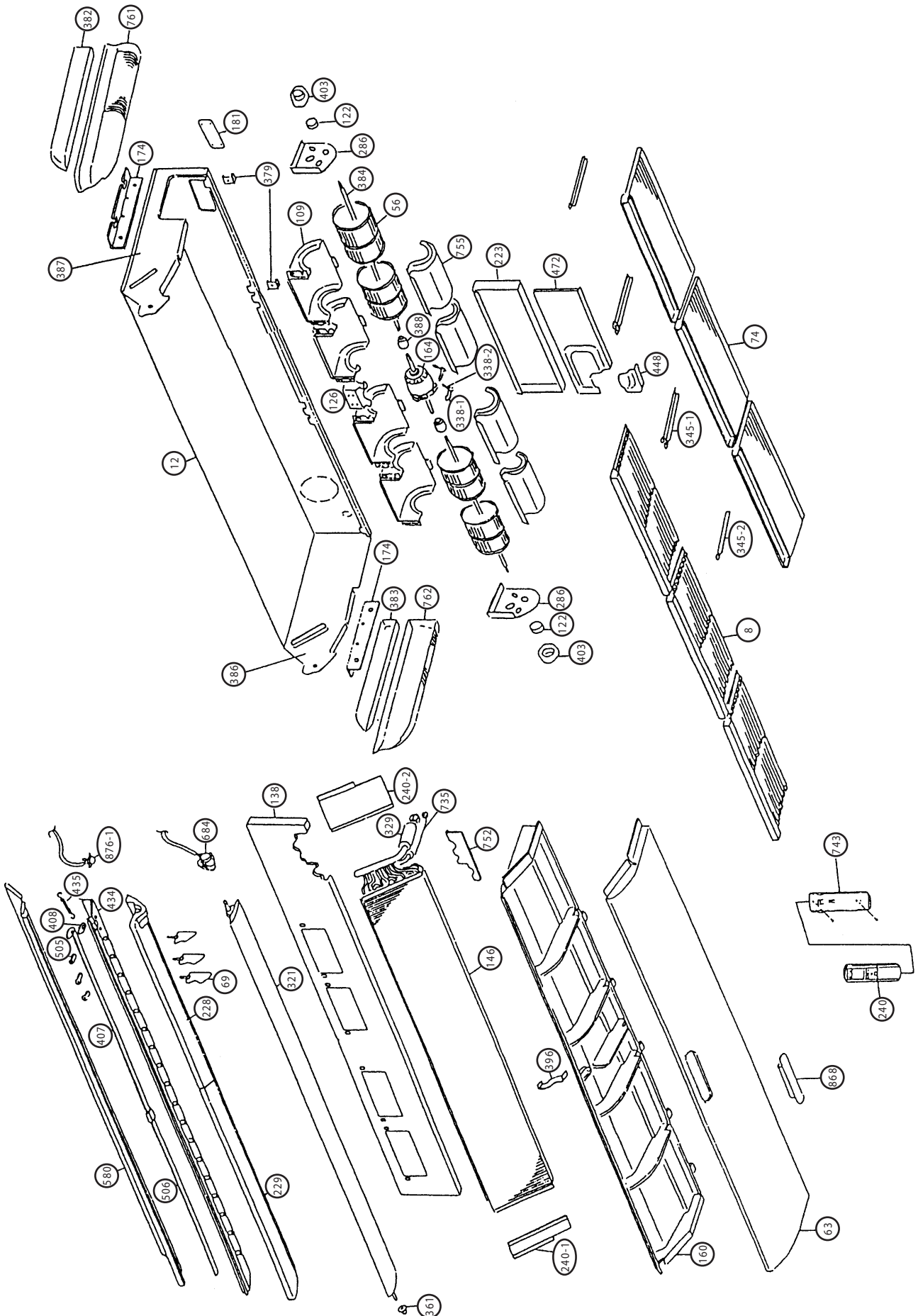

Models : ABY30FBAG
ABY30UBAG

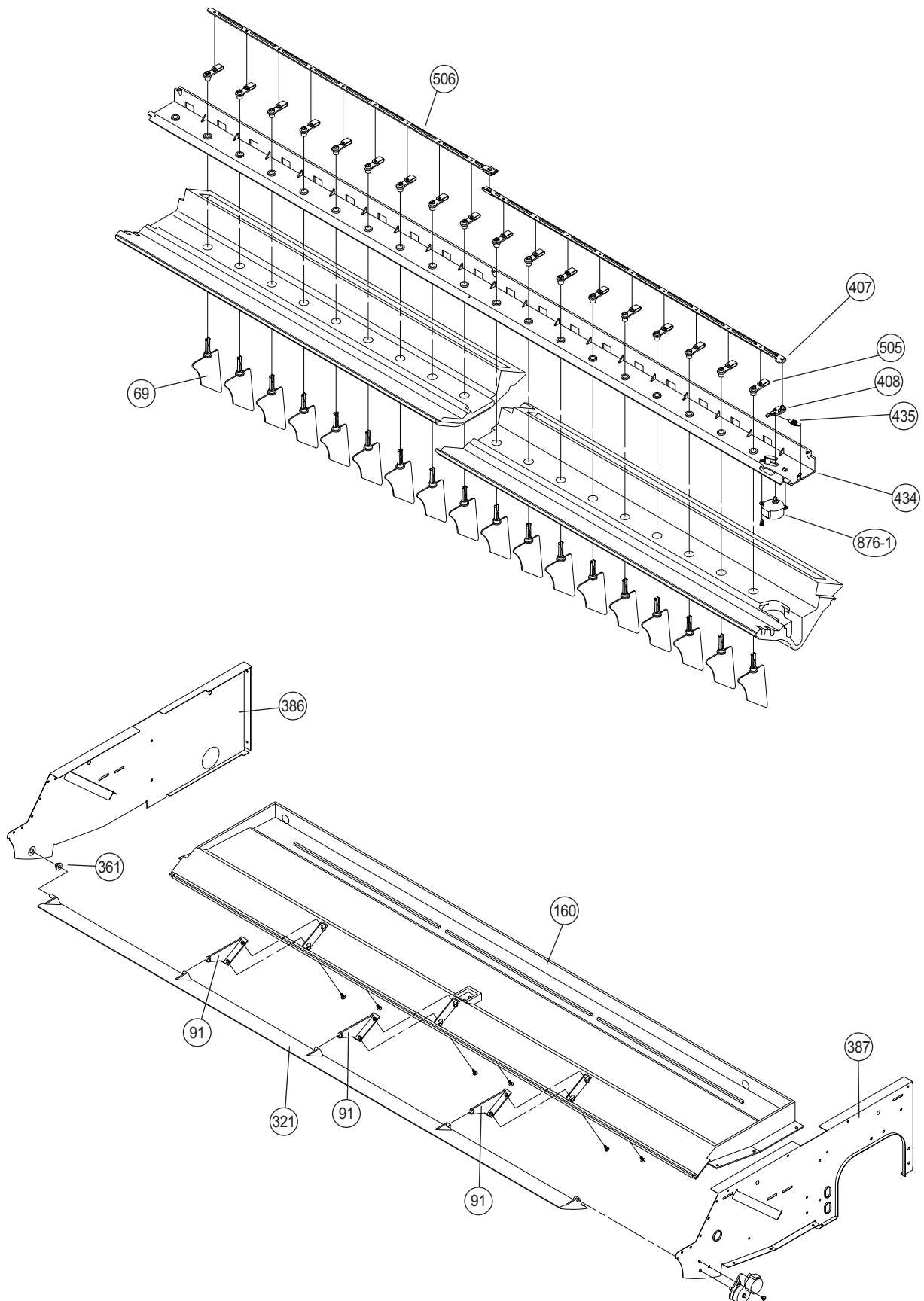

**Models : ABY30FBAG
ABY30UBAG**

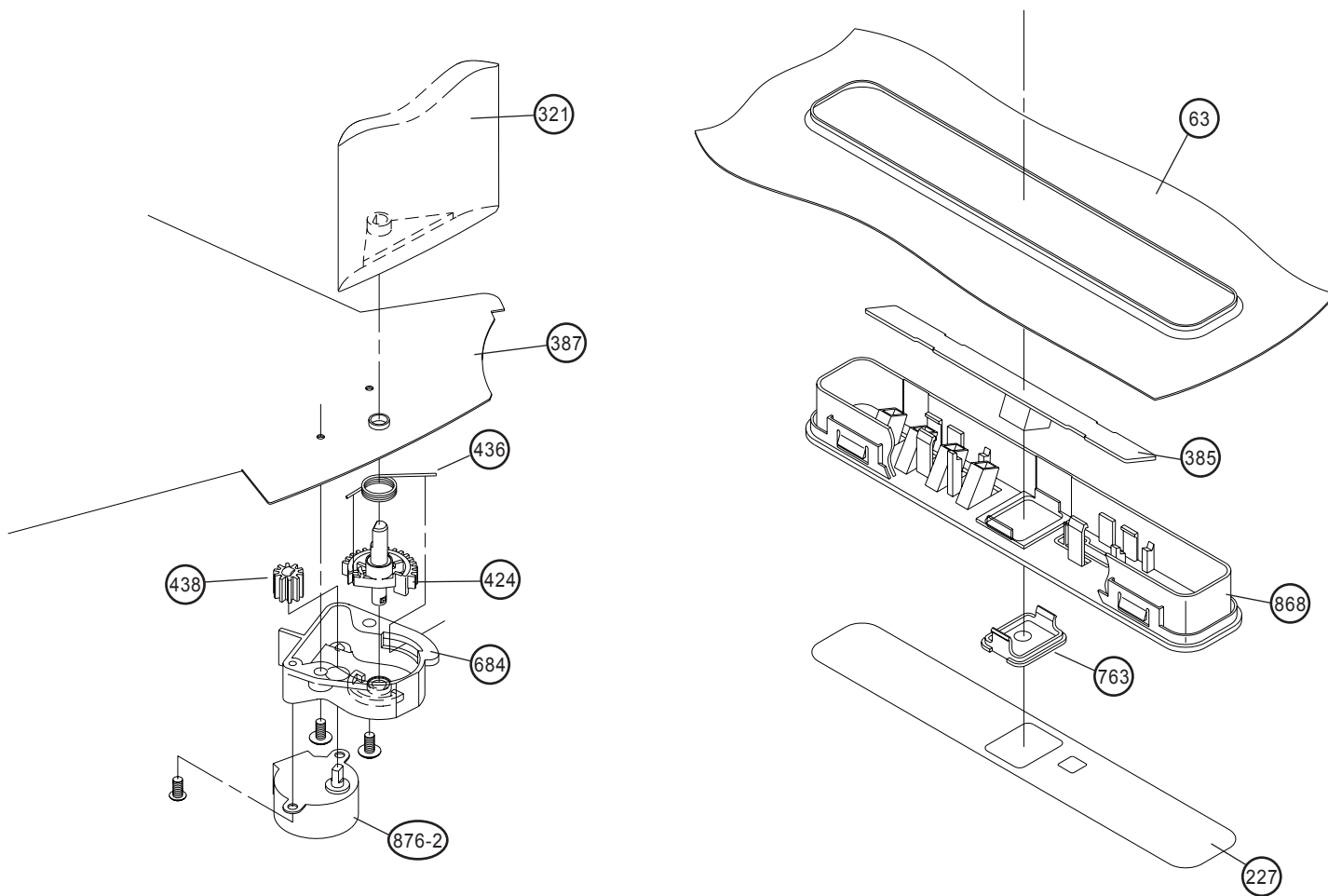

Models : ABY30FBAG
ABY30UBAG

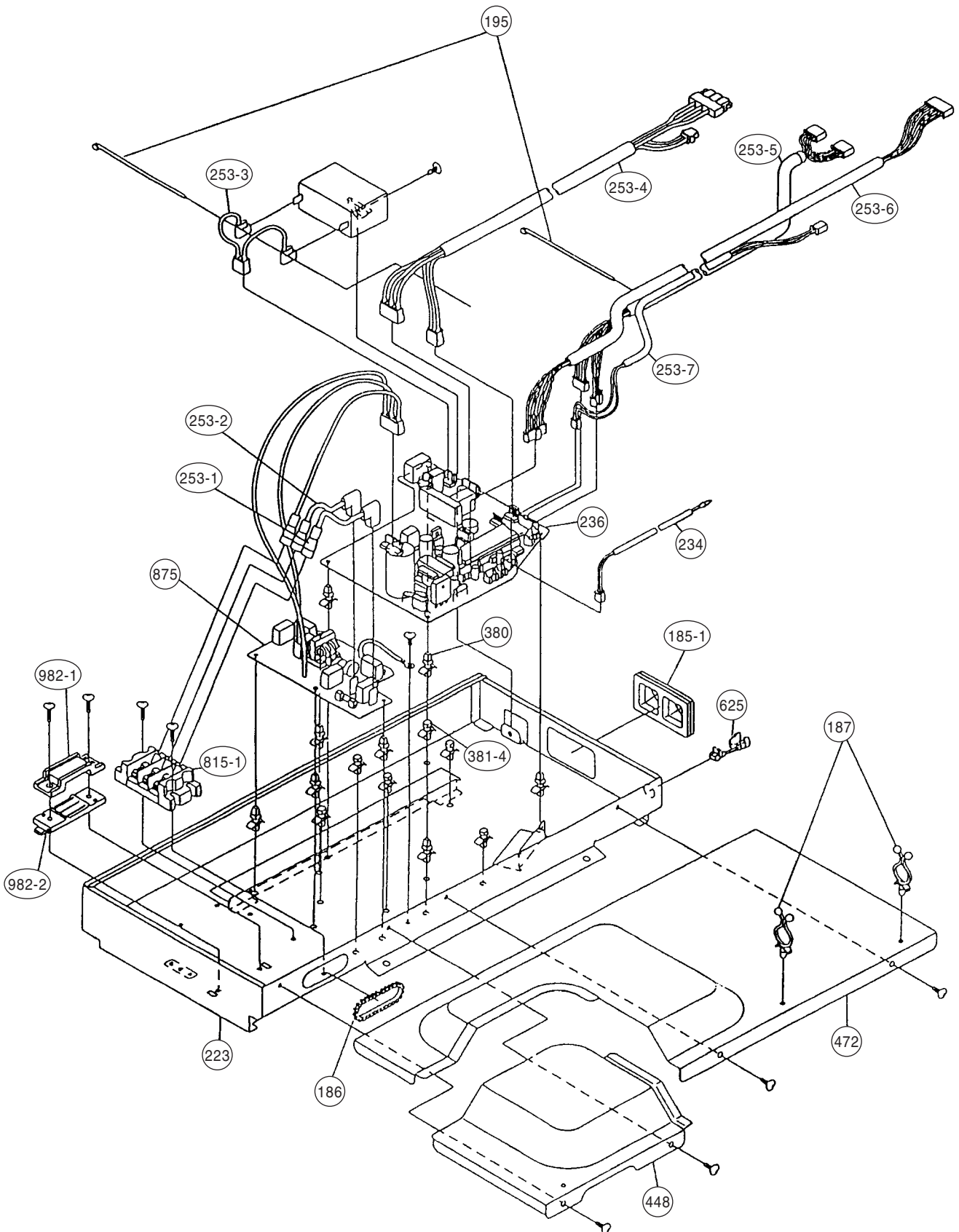

Models :
AOY30FNBWL
AOY30UNBWL

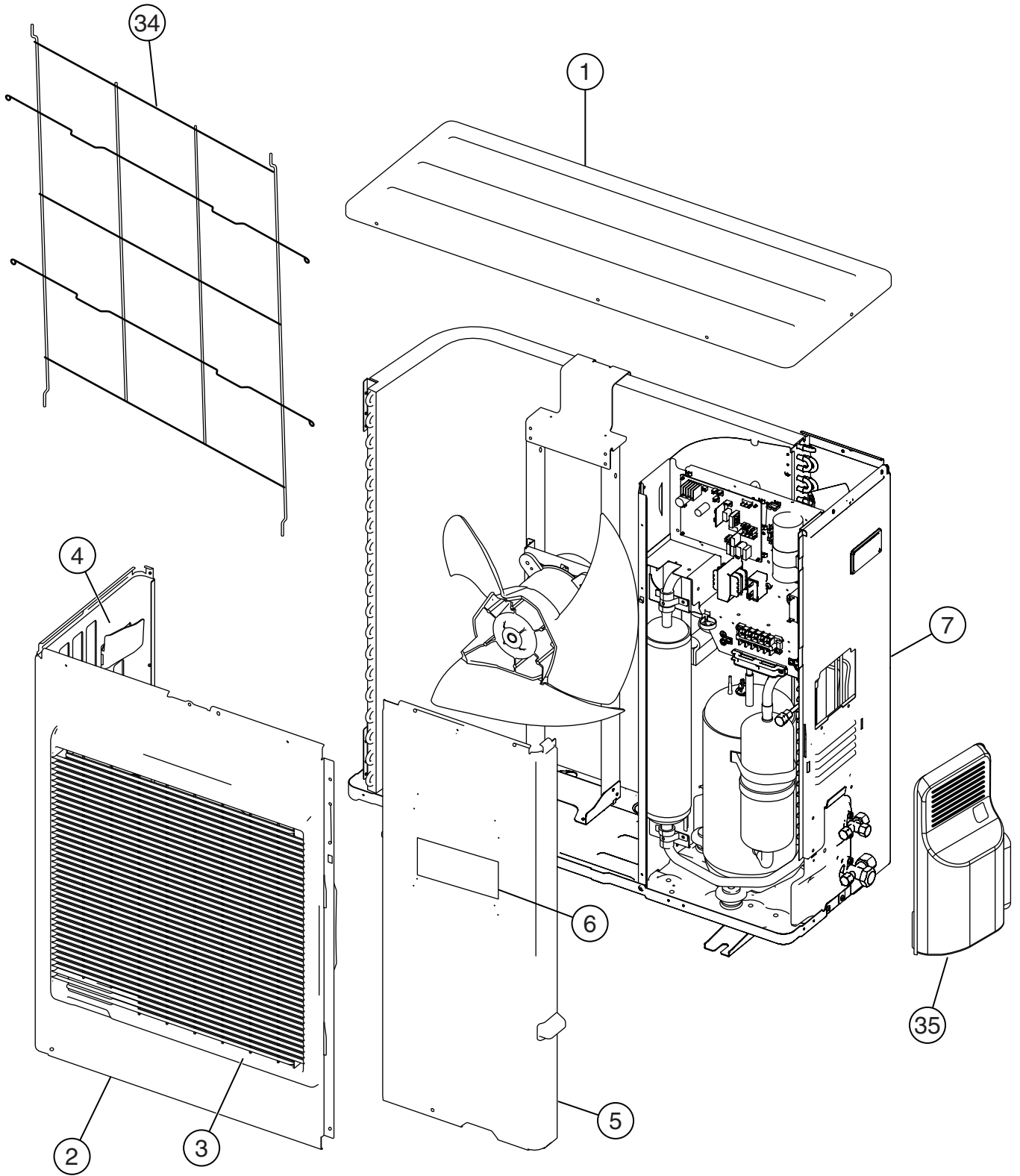

Models :
AOY30FNBWL
AOY30UNBWL

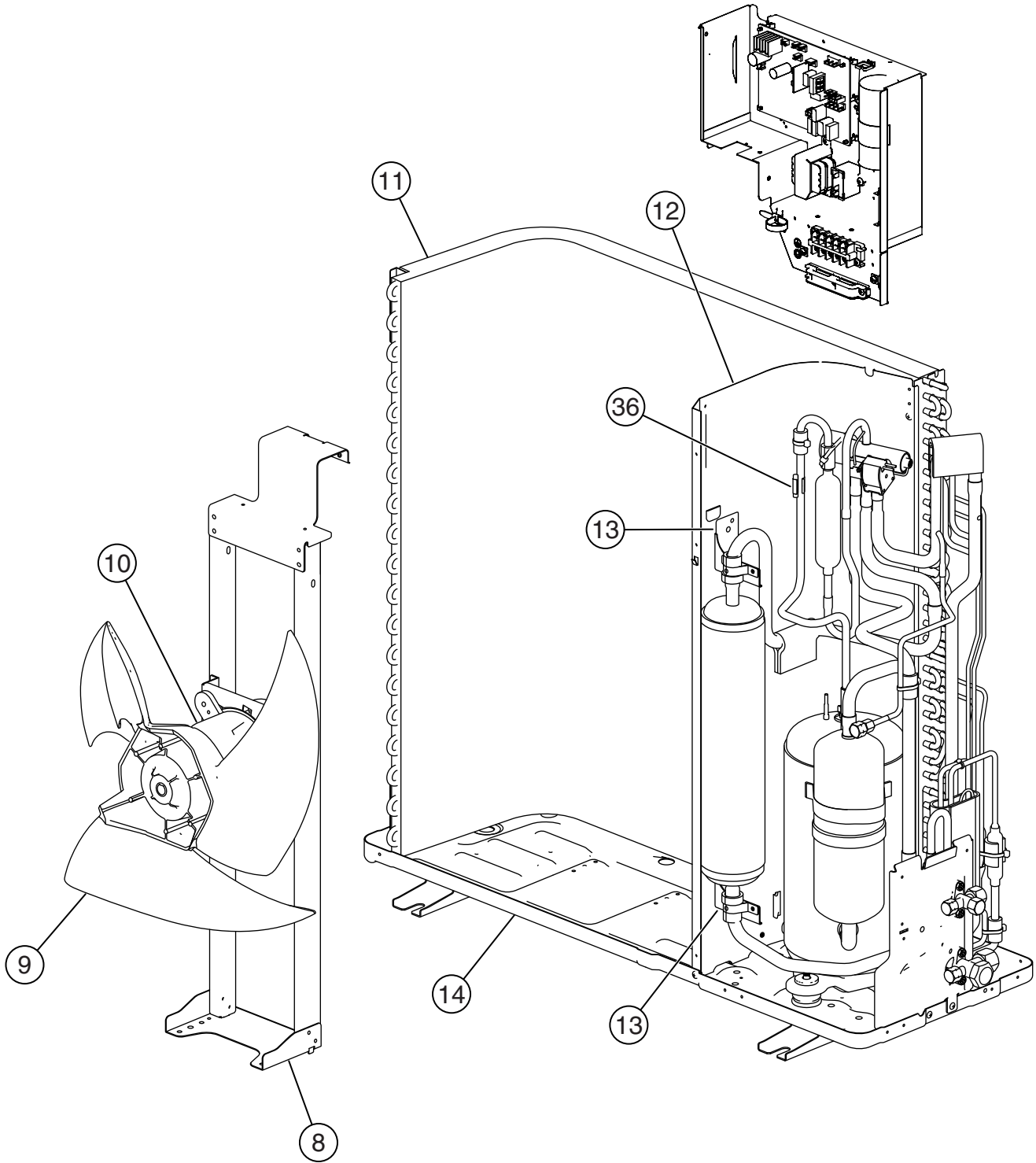

Model :
AOY30FNBWL

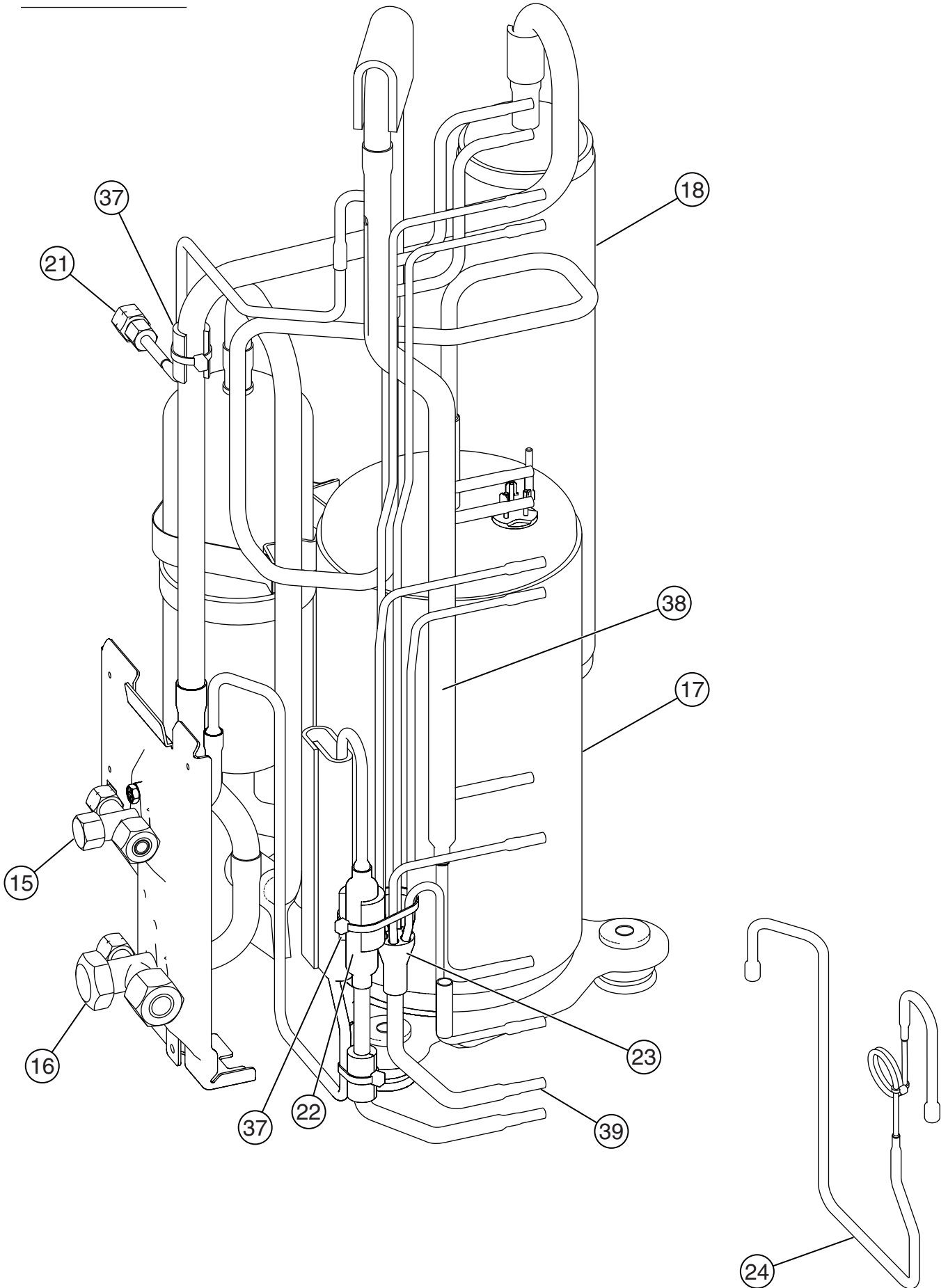

Model :
AOY30UNBWL

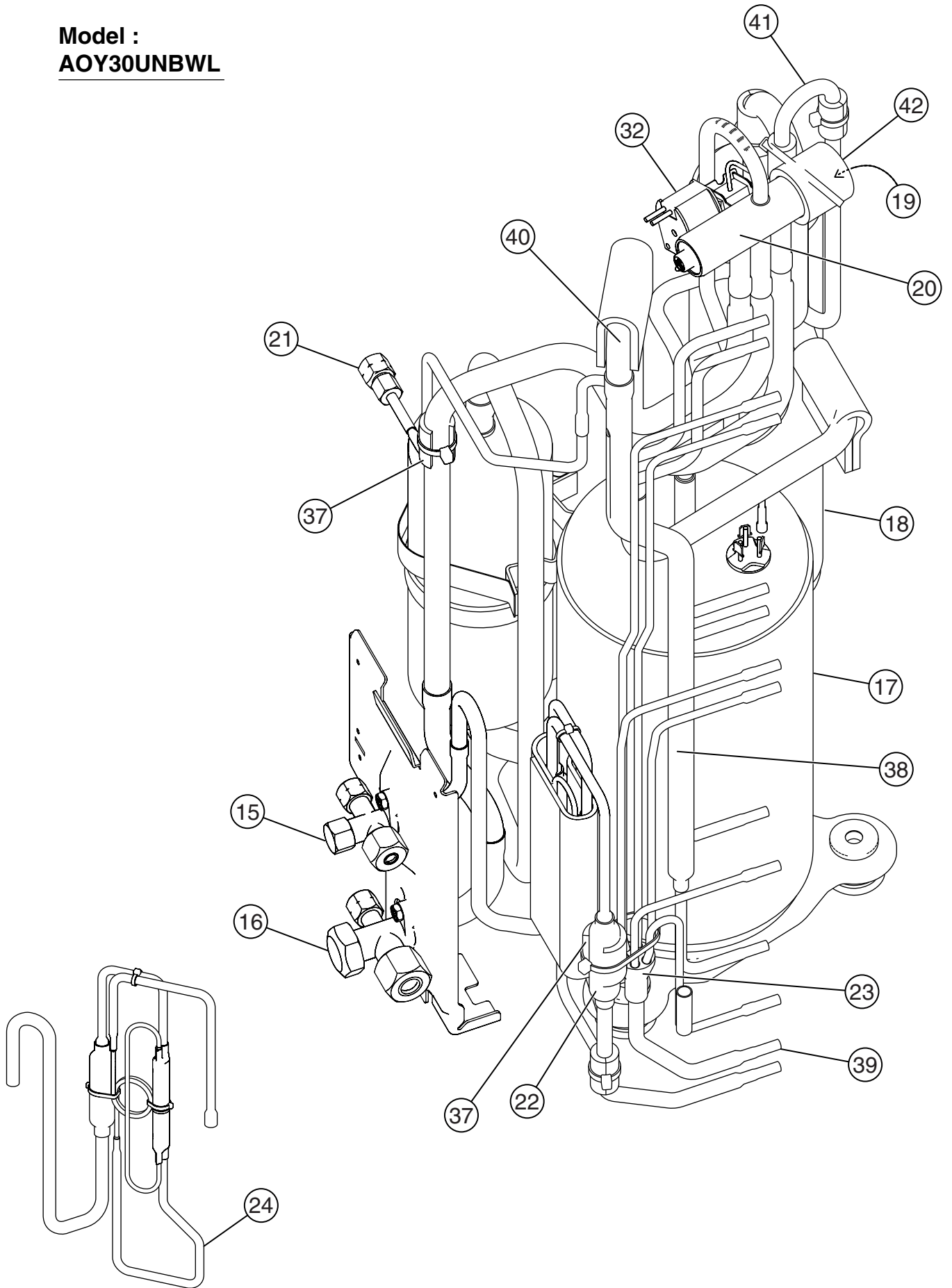

Model :
AOY30FNBWL

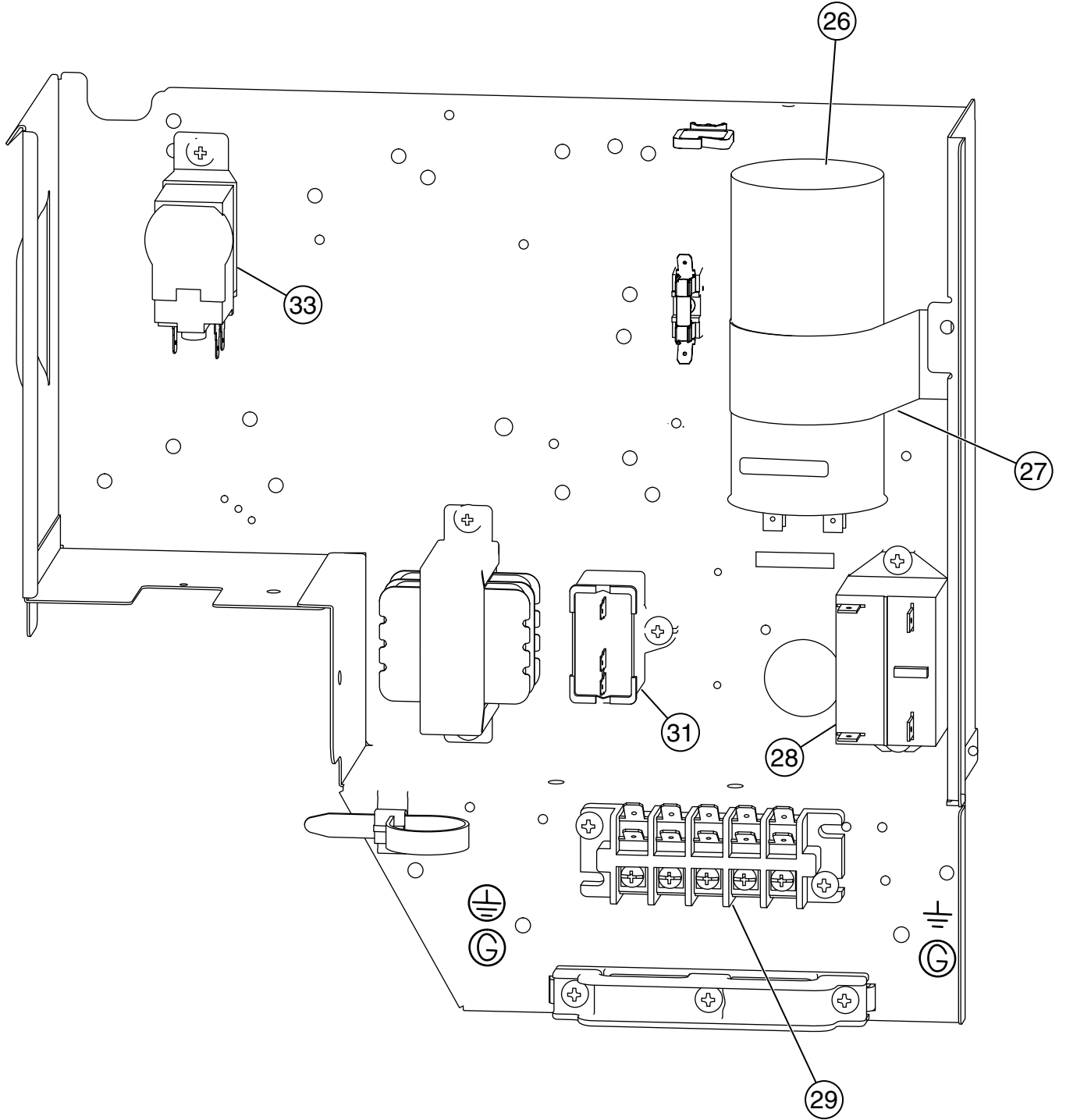

Model :
AOY30UNBWL

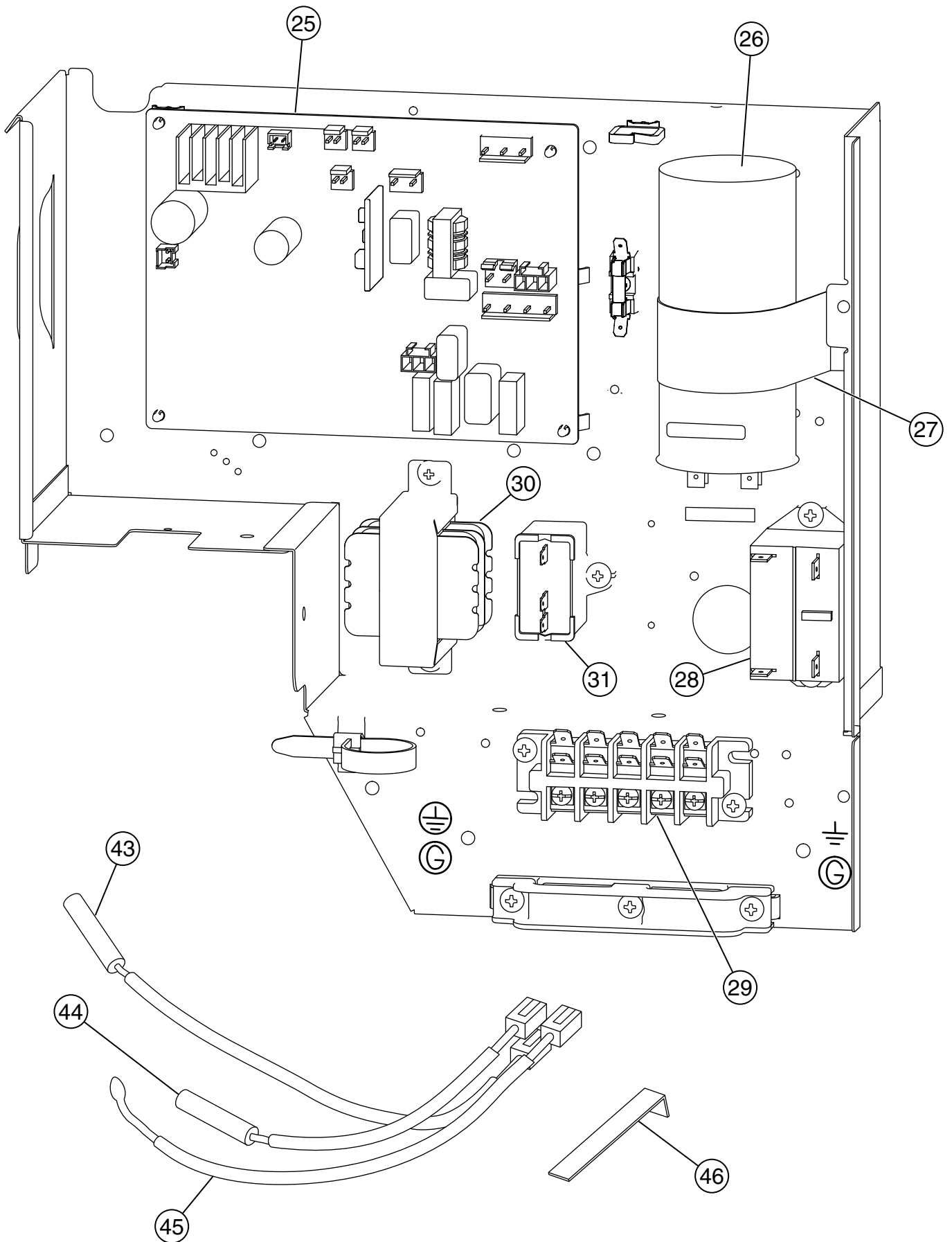

PARTS LIST

INDOOR UNIT

Ref. No.	Description	Part No.		Ord. Q'ty	Ref. No.	Description	Part No.		Ord. Q'ty
		ABY30FBAG	ABY30UBAG				ABY30FBAG	ABY30UBAG	
8	Air Filter	9359739005	9359739005		338-1	Fixture (Motor)	9359702009	9359702009	
12	Base Assy	9359680000	9359680000		338-2	Fixture (Motor)-B	9359703006	9359703006	
56	Sirocco Fan Assy	9359701002	9359701002		345-1	Filter Guide-R	9359692003	9359692003	
63	Panel (Front)	9359734000	9359734000		345-2	Filter Guide-L	9359693000	9359693000	
69	Louver	9359719007	9359719007		361	Bushing	9359733003	9359733003	
74	Intake Grille	9359738008	9359738008		379	Hinge Plate (Grille)	9359694007	9359694007	
91	Hinge	9359699002	9359699002		380	Locking Spacer KGLS-6S	313209391403	313209391403	
109	Casing	9359704003	9359704003		381-4	Spacer	0600118075	0600118075	
122	Bearing-B Assy	9357921006	9357921006		382	Cover (Decoration)-R	9359744009	9359744009	
126	Bracket (Motor)	9359681007	9359681007		383	Cover (Decoration)-L	9359745006	9359745006	
138	Separate Wall	9359700005	9359700005		384	Shaft	9359707004	9359707004	
146	Evaporator Assy	9371073057	9371073057		385	Indicator PCB Assy	9702260019	9702260019	
160	Drain Pan	9359698005	9359698005		386	Panel Left Assy	9359685005	9359685005	
164	Fan Motor Assy-IN	9360457004	9360457004		387	Panel Right Assy	9359683001	9359683001	
174	Hanger	9359742005	9359742005		388	Joint Assy	9359706007	9359706007	
181	Hole Cover	9359691006	9359691006		396	Rfm Bracket Metal	9359697008	9359697008	
185-1	Rubber Bushing	9357376004	9357376004		403	Fixture (Bearing)	9359687009	9359687009	
186	Cover (Edge)	9361049017	9361049017		407	Rod (Motor)	9359723004	9359723004	
187	Clamp No.1219	313361271706	313361271706		408	Link (Louver)	9359726005	9359726005	
195	Clamp SKB-100	313361275805	313361275805		424	Sector Gear	9359729006	9359729006	
223	Control Box Assy	9359708001	9359708001		434	Base (Louver)	9359718000	9359718000	
227	Badge "FUJITSU"	9359735014	9359735014		435	Louver Spring	9359720003	9359720003	
228	Insulation (Louver)-R	9359721000	9359721000		436	Flap Spring	9359730002	9359730002	
229	Insulation (Louver)-L	9359722007	9359722007		438	Pinion Gear	9359728009	9359728009	
234	Thermistor	9703299025	9703299025		448	Control Box-B	9359713005	9359713005	
236	Controller PCB Assy	9704557247 (EZ-0020FWSE-C)	9704557230 (EZ-00227HSE-C)		472	Control Box-A	9359712008	9359712008	
240	Remote Control Unit	9374322022	9374322015		505	Stopper (Louver)	9359724001	9359724001	
240-1	Cover Panel (Pipe)-L	9359690009	9359690009		506	Rod (Louver)	9359725008	9359725008	
240-2	Cover Panel (Pipe)-R	9359689003	9359689003		580	Cover (Top)	9359737001	9359737001	
253-1	Wire Assy (Terminal)	9702321017	9702321017		625	Cord Bushing	9359240006	9359240006	
253-2	Wire Assy (Terminal)	9702322014	9702322014		684	Motor Base	9359727002	9359727002	
253-3	Wire Assembly	9702311018	9702311018		735	Distributor Assy	9371325118	9371325118	
253-4	Wire Assy (Connector)	9702323011	9702323011		743	Remote Control Holder Case	9305642014	9305642014	
253-5	Wire Assy (Connector)	9702319014	9702319014		752	Bracket Panel (Pipe)	9359688006	9359688006	
253-6	Wire Assy (Connector)	9702317010	9702317010		755	Cover (Casing)	9359705000	9359705000	
253-7	Wire Assy (Connector)	9702318017	9702318017		761	Cover (Side)-R	9359740001	9359740001	
286	Bracket (Bearing)	9359686002	9359686002		762	Cover (Side)-L	9359741008	9359741008	
321	Flap Assy	9359731009	9359731009		763	Cover (Receiver)	9359714002	9359714002	
329	Coupling Pipe Assy	9373038191	9373038191		815-1	Terminal-3P	9900203016	9900203016	
					868	PCB Holder	9359736004	9359736004	
					875	Power Supply PCB Assy	9704561138	9704561060	
					876-1	Motor, Step-H	9360479013	9360479013	
					876-2	Motor, Step-V	9360307026	9360307026	
					982-1	Cord Clamp-A	9359820017	9359820017	
					982-2	Cord Clamp-B	9359821014	9359821014	

OUTDOOR UNIT





Ref. No.	Description	Part No.	Ord. Q'ty
		AOY30FNBWL	
1	Top Panel Sub Assy	9374417018	
2	Front Panel	9374094066	
3	Fan Guard	9374330010	
4	Grip Side	9374173013	
5	Service Panel Sub Assy	9374415038	
6	Emblem-Rear	9351355005	
7	Right Panel Sub Assy	9374416035	
8	Motor Bracket Sub Assy	9374418039	
9	Propeller Fan Assy	9366378013	
10	Fan Motor	9601671060	
11	Condenser Assy	9374433063	
12	Separate Wall Sub Assy	9374413034	
13	Accumulator Support-B	9355350006	
14	Base Assy	9374166046	
15	3-Way Valve Assy	9372205044	
16	3-Way Valve Assy	9372205075	
17	Compressor Assy	9372558089	
18	Accumulator	9374338016	
21	Check Valve Assy	9374274024	
22	Strainer Assy	9372524015	
23	Distributor	9369128004	
24	Capillary Assy	9372197349	
26	Capacitor Plastic	9900269081	
27	Capacitor Clamp	9351770013	
28	Relay	9900074012	
29	Terminal 5P	9900203023	
31	Capacitor (Fan)	9900270049	
33	Thermostat Outdoor	9900275013	
34	PRT Net M	9374255030	
35	Valve Cover	9374174010	
36	Thermostat Holder	9357804002	
37	Capillary Holder Rubber	313394274808	
38	IN PP(COND)A Assy	9373461067	
39	OUT PP(CND)A Assy	9374266050	
	Special Nut M5 (compressor)	9300301015	
	Discharge A Assy	9372264089	
	IN PP(COND)C Assy	9374469017	
	Cover Gasket (Comp)	9371512013	
	Terminal Cover (Compressor)	9371511016	
	Rubber Seat (Compressor)	9351049010	
	Compressor Cover	9374430031	



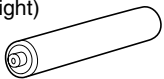
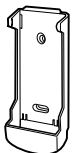

Ref. No.	Description	Part No.	Ord. Q'ty
		AOY30UNBWL	
1	Top Panel Sub Assy	9374417018	
2	Front Panel	9374094066	
3	Fan Guard	9374330010	
4	Grip Side	9374173013	
5	Service Panel Sub Assy	9374415038	
6	Emblem-Rear	9351355005	
7	Right Panel Sub Assy	9374416035	
8	Motor Bracket Sub Assy	9374418039	
9	Propeller Fan Assy	9366378013	
10	Fan Motor	9601671060	
11	Condenser Assy	9374433056	
12	Separate Wall Sub Assy	9374413034	
13	Accumulator Support-B	9355350006	
14	Base Assy	9374166046	
15	3-Way Valve Assy	9372205044	
16	3-Way Valve Assy	9372205075	
17	Compressor Assy	9372558089	
18	Accumulator	9374338016	
19	Muffler	9372369012	
20	4-Way Valve	9900163013	
21	Check Valve Assy	9374274024	
22	Strainer Assy	9372524015	
23	Distributor	9369128004	
24	Capillary Assy	9372197325	
25	Controller PCB Assy	9704299024	
26	Capacitor Plastic	9900269081	
27	Capacitor Clamp	9351770013	
28	Relay	9900074029	
29	Terminal 5P	9900203023	
30	Transformer	9900039011	
31	Capacitor (Fan)	9900270049	
32	Solenoid	9900165055	
34	PRT Net M	9374255030	
35	Valve Cover	9374174010	
36	Thermostat Holder	9357804002	
37	Capillary Holder Rubber	313394274808	
38	IN PP(COND)A Assy	9373461067	
39	OUT PP(CND)A AS	9374266050	
40	IN PP(COND)C Assy	9374469017	
41	Discharge B Assy	9372246054	
42	4-Way Valve Rubber	313728251908	
43	Heat Exchanger Thermistor	9900043049	
44	Thermistor-Discharge	9900038038	
45	Thermistor (Out Temp)	9900037048	
46	Thermo. Spring -A	313728262708	
	Cover Gasket (Comp)	9371512013	
	Terminal Cover (Compressor)	9371511016	
	Rubber Seat (Compressor)	9351049010	
	Compressor Cover	9374430031	
	Varistor	0000361224	
	Varistor (Arrester)	0600280154	
	Relay	9900200015	
	Belt Heater	9361140257	
	Special Nut M5 (compressor)	9300301015	

STANDARD ACCESSORIES

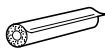

The following installation parts are furnished. Use them as required.

INDOOR UNIT ACCESSORIES

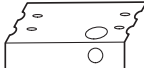
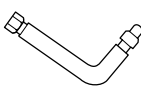
Name and Shape	Q'ty	Application
Remote control unit 	1	Use for air conditioner operation
Battery (penlight) 	2	For remote control unit
Remote control unit holder 	1	For mounting the remote control unit
Tapping screw (ø3 x 12) 	2	For remote control unit holder installation
Drain hose insulation 	1	Adhesive type 70 x 230
VT wire 	1	For fixing the drain hose L 280 mm

Name and Shape	Q'ty	Application
Coupler heat insulator (large) 	2	For indoor side pipe joint (Gas pipe)
Coupler heat insulator (small) 	1	For indoor side pipe joint (Liquid pipe)
Nylon fastener 	Large 4 Small 4	For fixing the coupler heat insulator
Special nut A (large flange) 	4	For installing indoor unit
Special nut B (small flange) 	4	For installing indoor unit
Installation template 	1	For positioning the indoor unit
Auxiliary pipe assembly 	1	For connecting the piping

OUTDOOR UNIT ACCESSORIES

Name and Shape	Q'ty	Application
Drain pipe 	1	For outdoor unit drain piping work (May not be supplied, depending on the model.)
Drain cap 	2	
Insulation (seal) 	1	For filling in a gap at the entrance of connection cords

OPTIONAL PARTS

The following options are available.
DRAIN PUMP UNIT : UTR-DPB241 (P/N 9034087001)

0502G2754