

**INVERTER MULTI
AIR CONDITIONER
WALL MOUNTED type**

**SERVICE
MANUAL**



Models

Indoor unit

ASY7LMACW
ASY9LMACW
ASY12LMACW

Outdoor unit

AOY30LMAW4

CONTENTS

SPECIFICATIONS	1
OUTLINE AND DIMENSIONS	3
REFRIGERANT SYSTEM DIAGRAM	5
CIRCUIT DIAGRAM	6
INDOOR PCB CIRCUIT DIAGRAM	8
OUTDOOR PCB CIRCUIT DIAGRAM	9
ERROR CONTENTS	12
DISASSEMBLY ILLUSTRATION	13
PARTS LIST	21

SPECIFICATIONS

INDOOR UNIT

TYPE	COOL & HEAT		
INDOOR UNIT	ASY7LMACW	ASY9LMACW	ASY12LMACW

ELECTRICAL DATA (INDOOR UNIT)

COOLING CAPACITY	(kW)	2.2	2.7	3.5
HEATING CAPACITY	(kW)	2.6	3.2	4.0
MOISTURE REMOVAL	(ℓ /hr)	1.0	1.2	1.6
AIR CIRCULATION-Hi	(m ³ /hr)	430	480	530

FAN MOTOR

POWER SOURCE		230 - 240 V		
INDOOR UNIT	DISCRIMINATION	MFA-40GR	MFA-40GR	MFA-40GR
	HI (r.p.m.)	1,000 - 1,000	1,200 - 1,200	1,310 - 1,310
	MED (r.p.m.)	900 - 900	1,100 - 1,100	1,260 - 1,260
	LO (r.p.m.)	850 - 850	1,000 - 1,000	1,190 - 1,190
	QUIET (r.p.m.)	800 - 800	940 - 940	1,100 - 1,100

DIMENSIONS	H x W x D	257 x 808 x 187 mm
WEIGHT	GROSS / NET	10 / 8 kg

NOISE LEVEL

INDOOR UNIT	High (dB)	34	36	38
	Low (dB)	29	29	33

OUTDOOR UNIT

TYPE	Cooling & Heating
MODEL NAME	AOY30LMAW4
COOLING CAPACITY	8.0 kW
HEATING CAPACITY	9.6 kW

ELECTRICAL SPECIFICATIONS

POWER SUPPLY		(220) - 230 - (240) V
FREQUENCY		50 Hz
RUNNING CURRENT (A)	COOLING	9.7
	HEATING	10.5
INPUT (kW)	COOLING	2.22
	HEATING	2.40
EER (kW/kW)	COOLING	3.60
	HEATING	4.00
AIR CIRCULATION - Hi (m ³ /hr)		3,300

COMPRESSOR

TYPE	Hermetic type, Inverter, 4 poles, 3-phase, DC motor, Twin Rotary
DISCRIMINATION	TNB220FPBM9
REFRIGERANT R410	3,300 g

FAN MOTOR

DISCRIMINATION	MFE-60PO
HI-SPEED (COOL)	820 r.p.m.
HI-SPEED (HEAT)	780 r.p.m.

DIMENSIONS H x W x D	830 x 900 x 330 mm
WEIGHT NET / GROSS	68 / 78 kg

REFRIGERANT CHARGE (R410A)

FULL CHARGE AMOUNT	Total Pipe Length 50.0 m	3,300 g
	60.0 m	3,550 g
	70.0 m	3,800 g
ADDITIONAL CHARGE		25 g / m
CHARGELESS		50 m
MAX PIPE LENGTH (each unit)		25 m
MAX PIPE LENGTH (total)		70 m
MAX ELEVATION (between indoor units)		10 m
MAX ELEVATION (between indoor and outdoor units)		10 m
MIN. PIPE LENGTH (each unit)		5 m

OUTLINE AND DIMENSIONS

INDOOR UNIT

Unit : mm

**Models : ASY12LMACW
ASY9LMACW
ASY7LMACW**

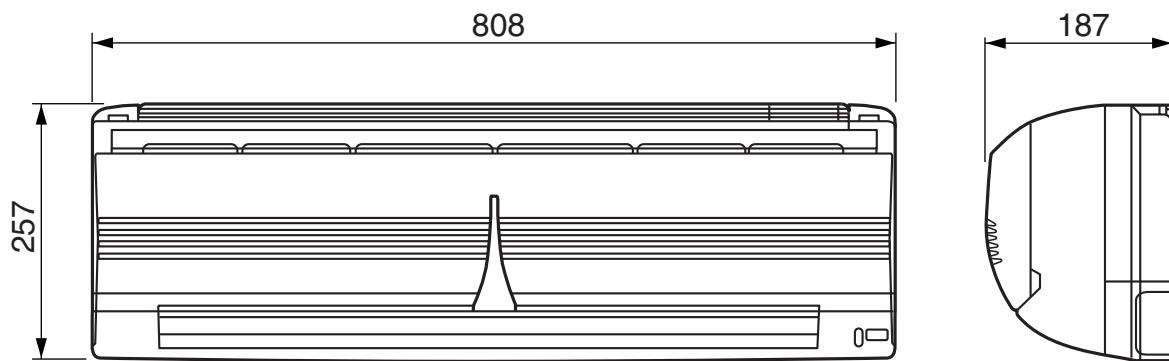

OUTDOOR UNIT (Unit : mm)

Model : AOY30LMAW4

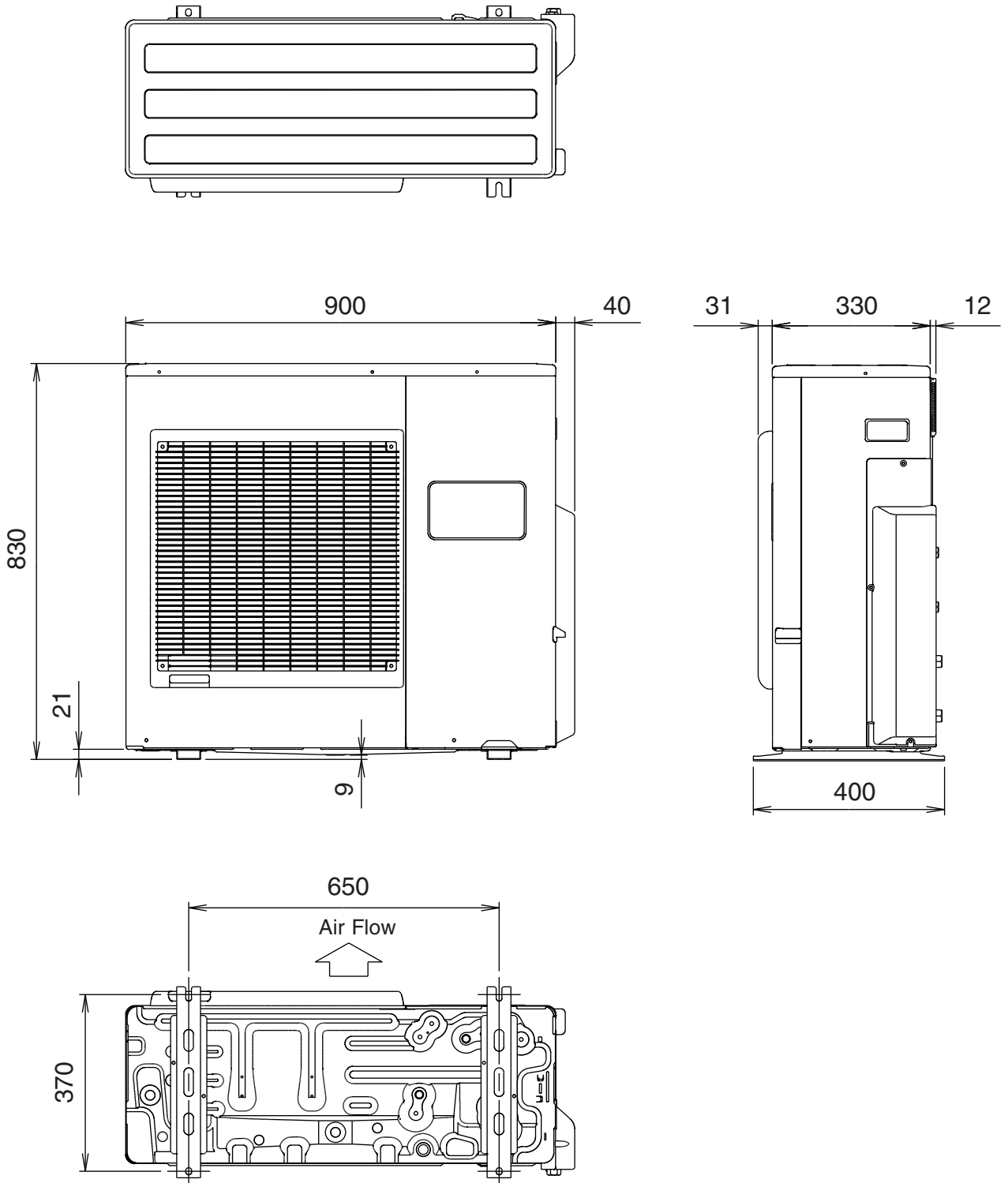

REFRIGERANT SYSTEM DIAGRAM

Outdoor unit

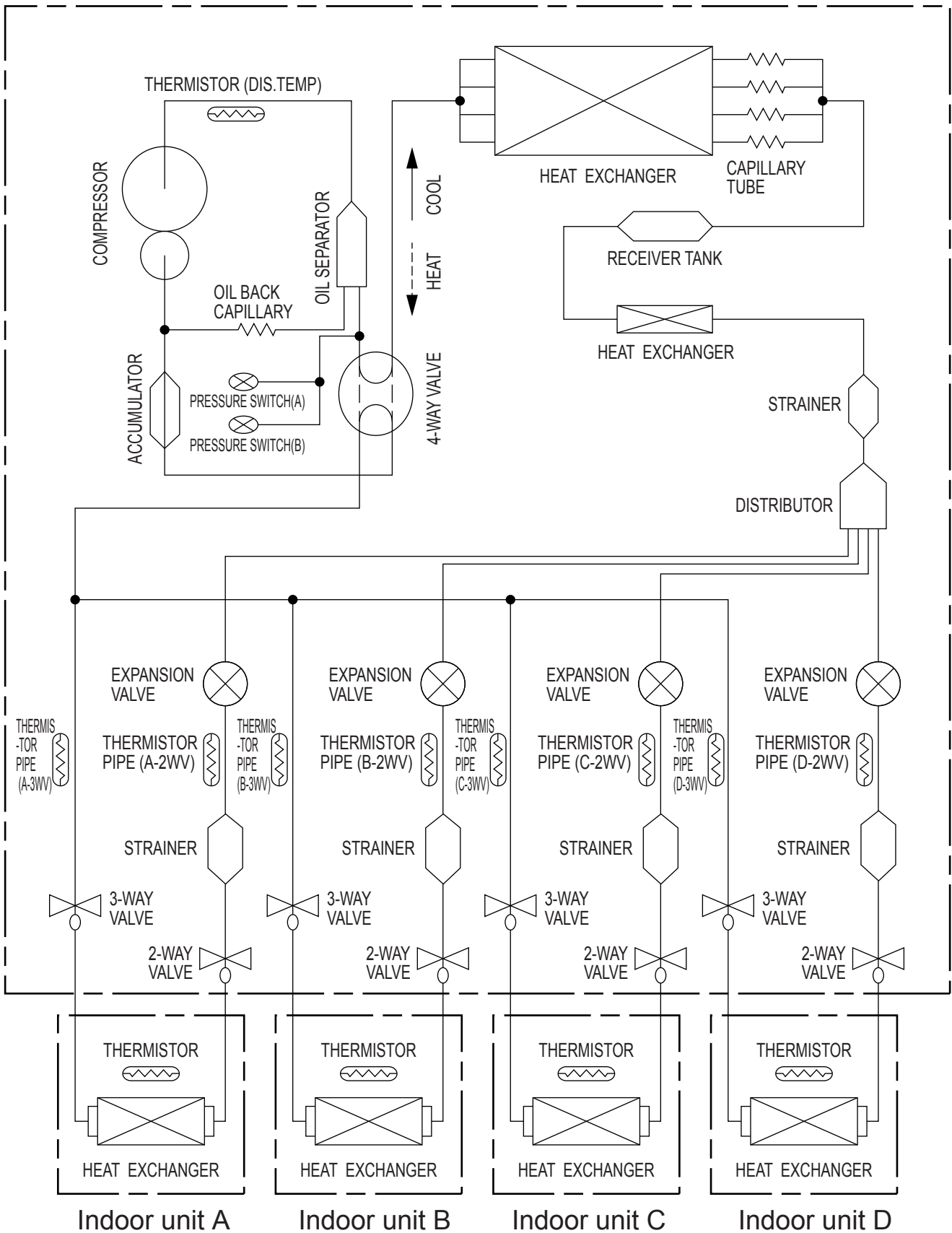

CIRCUIT DIAGRAM

INDOOR UNIT

**Models : ASY7LMACW
ASY9LMACW
ASY12LMACW**

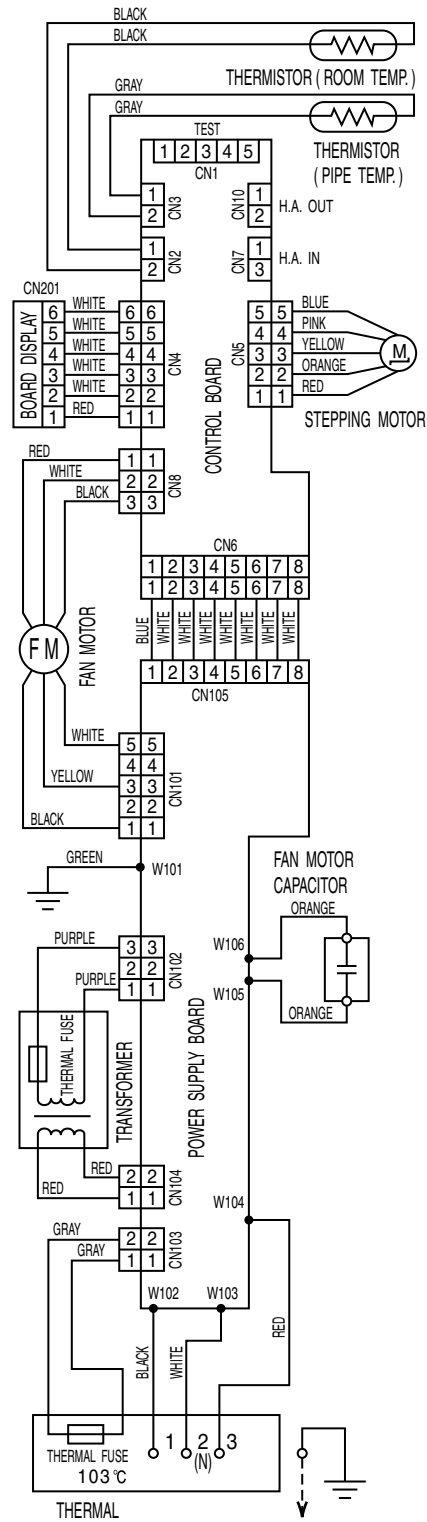

Model : AOY30LMAW4

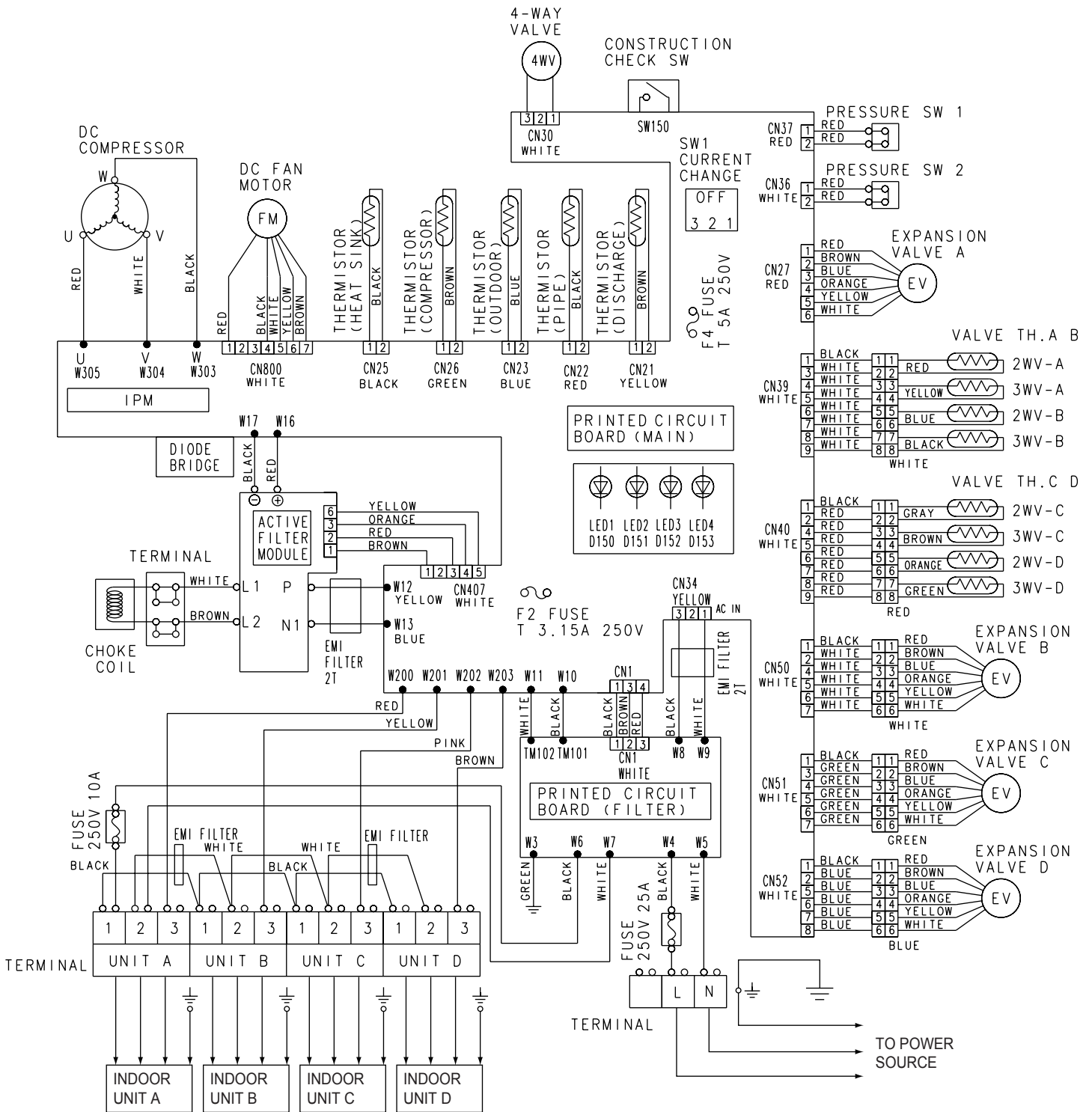

INDOOR PCB CIRCUIT DIAGRAM

Models : ASY7LMACW
ASY9LMACW
ASY12LMACW

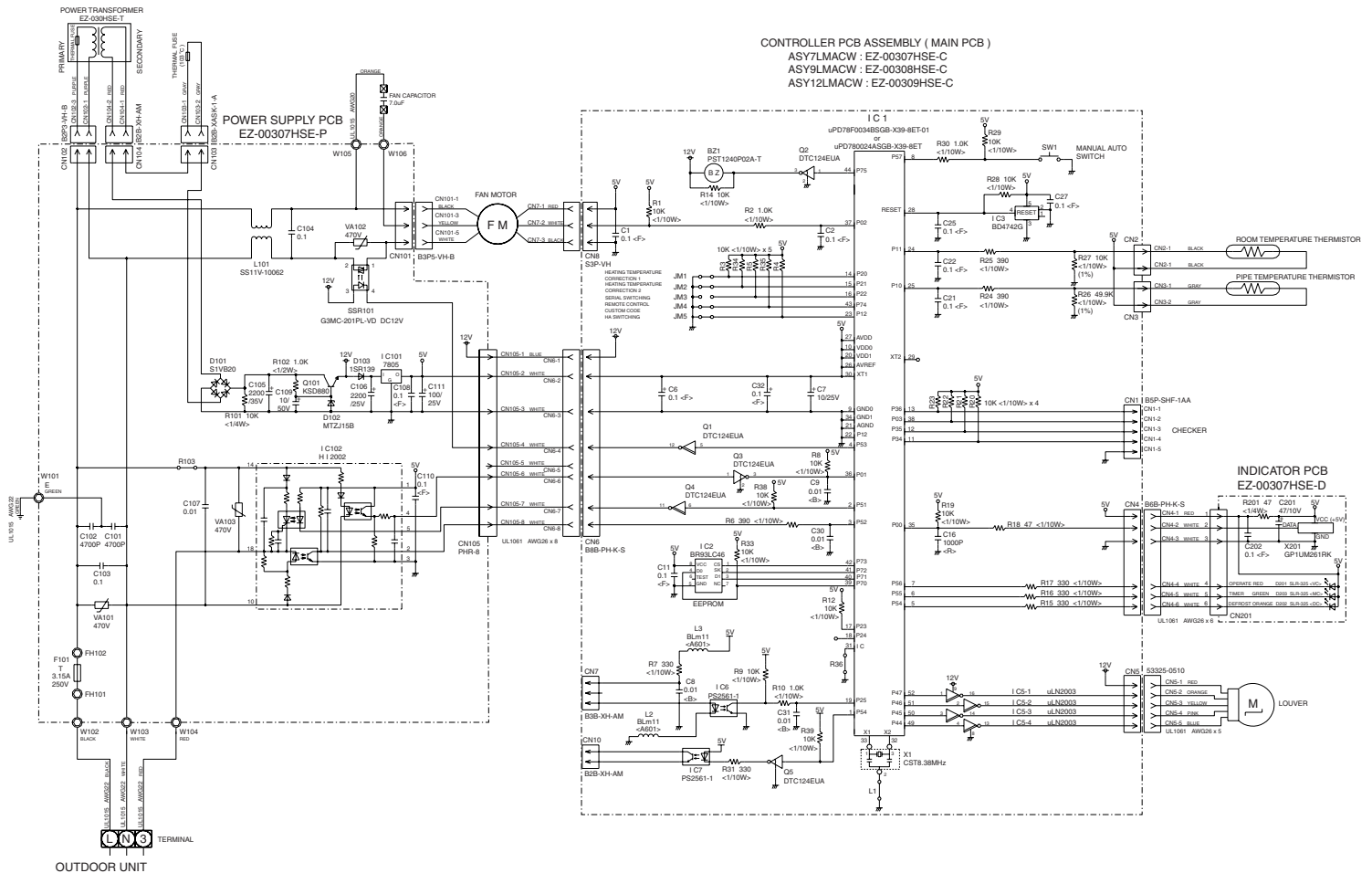

OUTDOOR PCB CIRCUIT DIAGRAM

Model : AOY30LMAW4

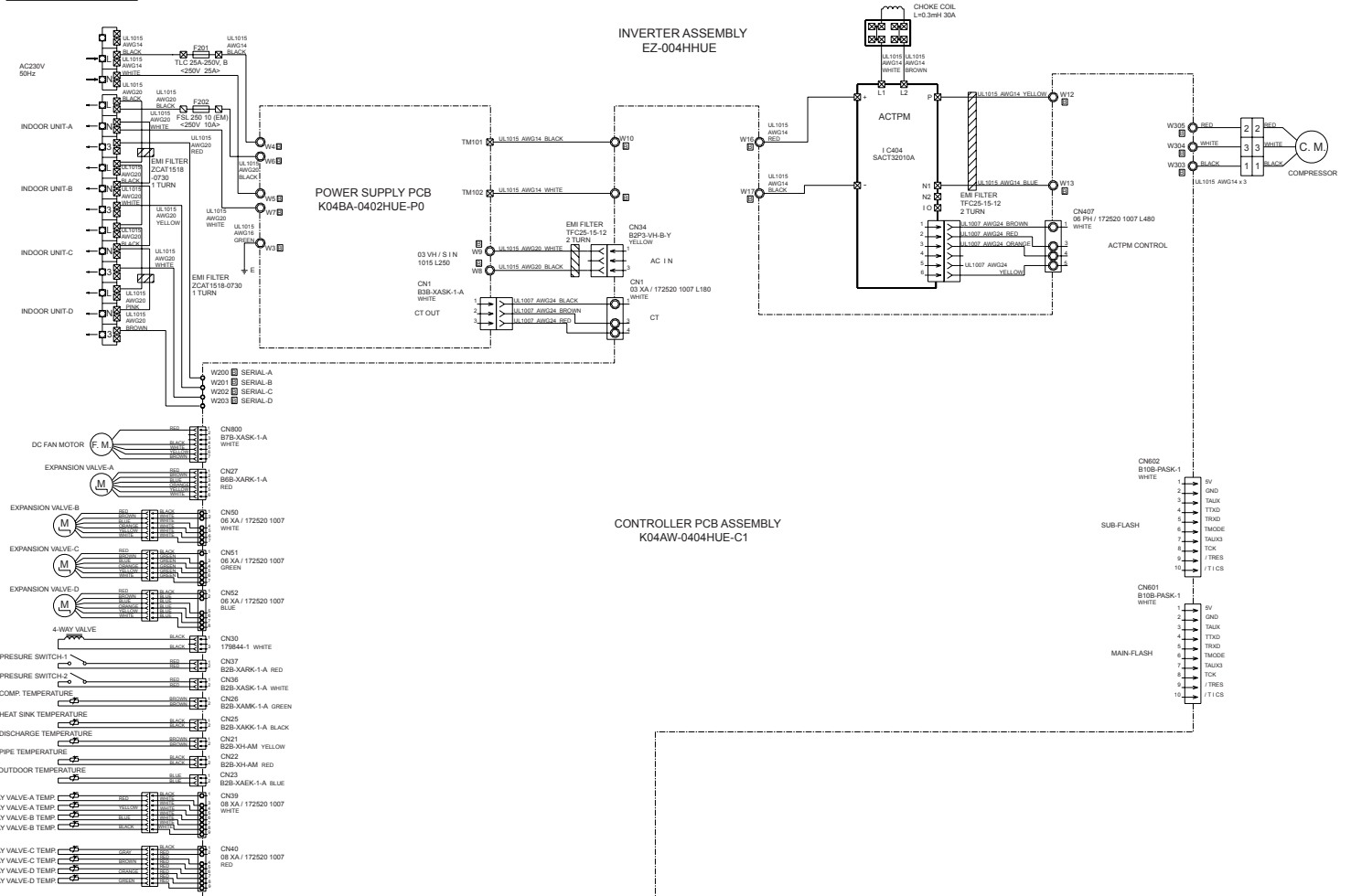

Model : AOY30LMAW4

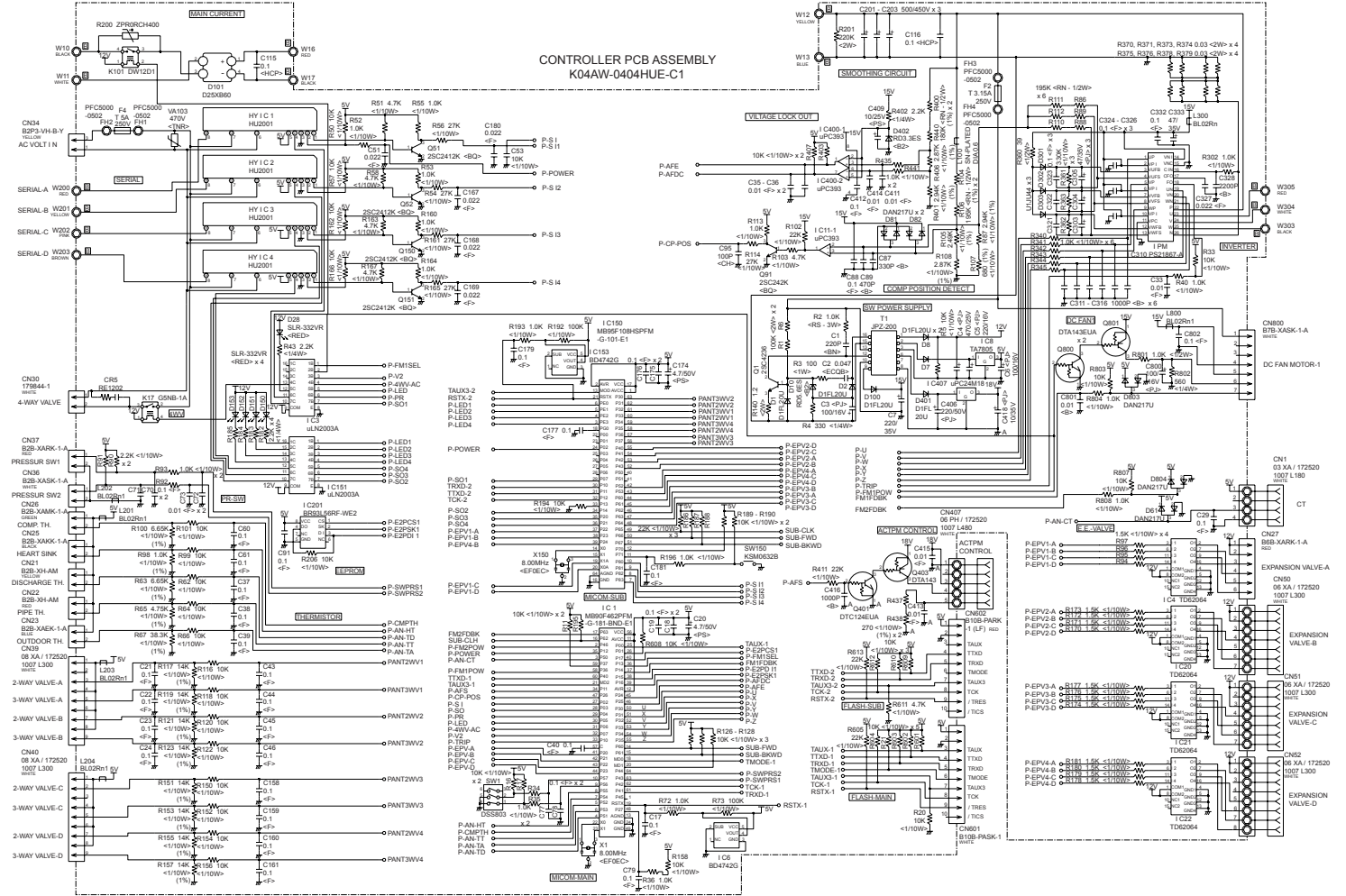

Model : AOY30LMAW4

**POWER SUPPLY PCB ASSEMBLY
K04BA-0400HUE-PO**

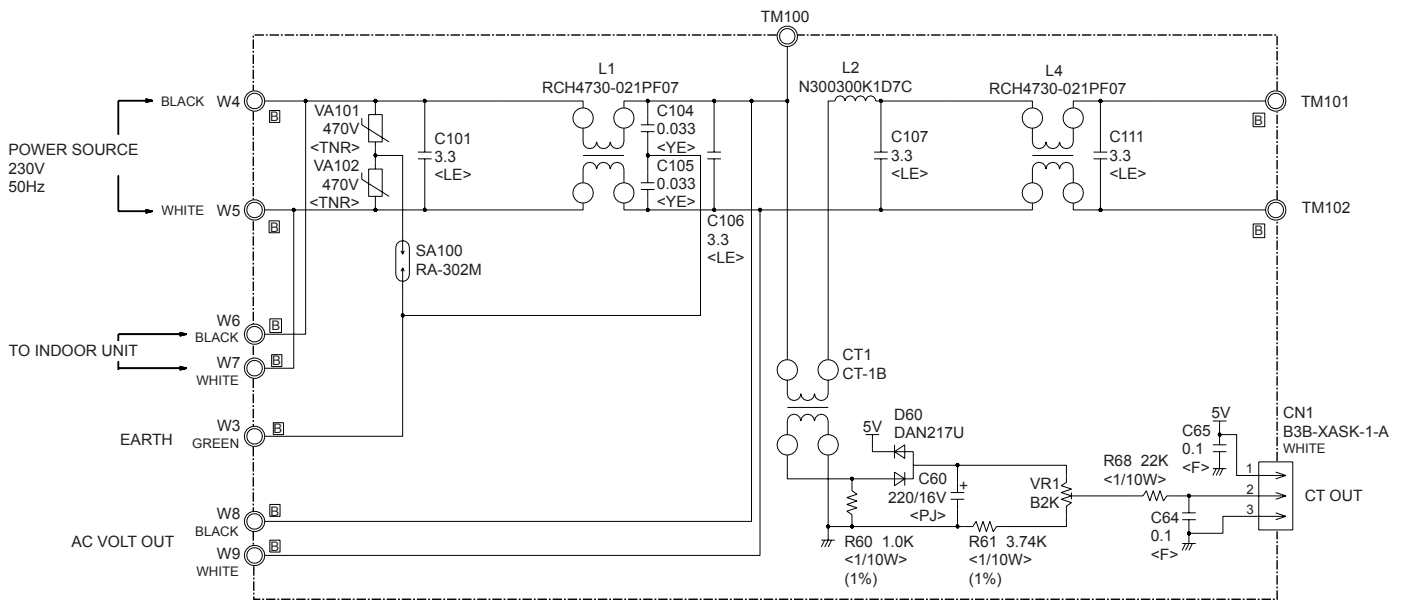

ERROR CONTENTS

INDOOR UNIT

○ : Fast flashing ● : Slow flashing

Operation lamp : Red lamp

Timer lamp : Green lamp

ASY12LMACW, ASY9LMACW, ASY7LMACW

Large division indication			Small division indication			
Error contents	LED indication		Error contents	LED indication		
Thermistor error (indoor unit)	Red lamp Green lamp	● (2 times) ○	Thermistor error (room temp.)	Red lamp	○	
			Thermistor error (heat exchanger)	Green lamp	● (2 times)	
Control unit error (indoor unit)	Red lamp Green lamp	● (4 times) ○	MANUAL AUTO button error	Red lamp	○	
			Power source Hz decision error	Green lamp	● (2 times)	
Serial error	Red lamp Green lamp	● (5 times) ○	Serial reverse transmission error	Red lamp	○	
			Serial order transmission error	Green lamp	● (2 times)	
Fan motor error (indoor unit)	Red lamp Green lamp	● (6 times) ○	Lock error	Red lamp	○	
			r.p.m error	Green lamp	● (2 times)	
Thermistor error (outdoor unit)	Red lamp Green lamp	○ ● (2 times)	Discharge thermistor error	Red lamp	● (2 times)	
			Heat exchanger thermistor error	Green lamp	○	
			Outdoor temperature thermistor error	Red lamp	● (4 times)	
			Compressor thermistor error	Green lamp	○	
			2 way valve thermistor error	Red lamp	● (6 times)	
			3 way valve thermistor error	Green lamp	○	
Pressure switch error	Red lamp Green lamp	○ ● (3 times)	Pressure switch error	Red lamp	● (8 times)	
Control unit error (outdoor unit)	Red lamp Green lamp	○ ● (4 times)	Capacity error of connecting indoor unit	Green lamp	○	
				Outdoor unit IPM error	Red lamp	● (2 times)
Inverter error	Red lamp Green lamp	○ ● (5 times)	Compressor loter location error	Green lamp	○	
				Red lamp	● (5 times)	
				Green lamp	○	

When an error occurs, "Large division indication" is indicated first.

Secondly, "Small division indication" is indicated by pushing "Test run" button of remote controller.

OUTDOOR UNIT LEDS

	LED A	LED B	LED C	LED D
Communication error (indoor unit A to outdoor unit)	● 1 time	—	—	—
Communication error (indoor unit B to outdoor unit)	—	● 1 time	—	—
Communication error (indoor unit C to outdoor unit)	—		● 1 time	—
Communication error (indoor unit D to outdoor unit)	—	—	—	● 1 time
Discharge pipe temperature sensor	● 2 times	—	—	—
Outdoor heat exchanger temperature sensor	● 3 times	—	—	—
Outdoor temperature sensor	● 4 times	—	—	—
Outdoor 2way valve(A) temperature sensor	● 5 times	—	—	—
Outdoor 2way valve(B) temperature sensor	—	● 5 times	—	—
Outdoor 2way valve(C) temperature sensor	—	—	● 5 times	
Outdoor 2way valve(D) temperature sensor	—	—	—	● 5 times
Outdoor 3way valve(A) temperature sensor	● 6 times	—	—	—
Outdoor 3way valve(B) temperature sensor	—	● 6 times	—	—
Outdoor 3way valve(C) temperature sensor	—	—	● 6 times	—
Outdoor 3way valve(D) temperature sensor	—	—	—	● 6 times
Compressor temperature sensor	● 7 times	—	—	—
Heatsink temperature sensor	● 8 times	—	—	—
Pressure switch A abnormal	● 9 times	—	—	—
Pressure switch B abnormal	● 10 times	—	—	—
Indoor unit connection capacity error	● 11 times	—	—	—
IPM error	● 12 times	—	—	—
Compressor later location error	● 13 times	—	—	—
Compressor can not start to operate	● 14 times	—	—	—
Outdoor fan (upper) motor error	● 15 times	—	—	—
Outdoor fan (lower) motor error	● 16 times	—	—	—
Microcomputer error	● 17 times	—	—	—

● : Slow flashing — : Off

DISAASSEMBLY ILLUSTRATION

Models : ASY12LMACW
ASY9LMACW
ASY7LMACW

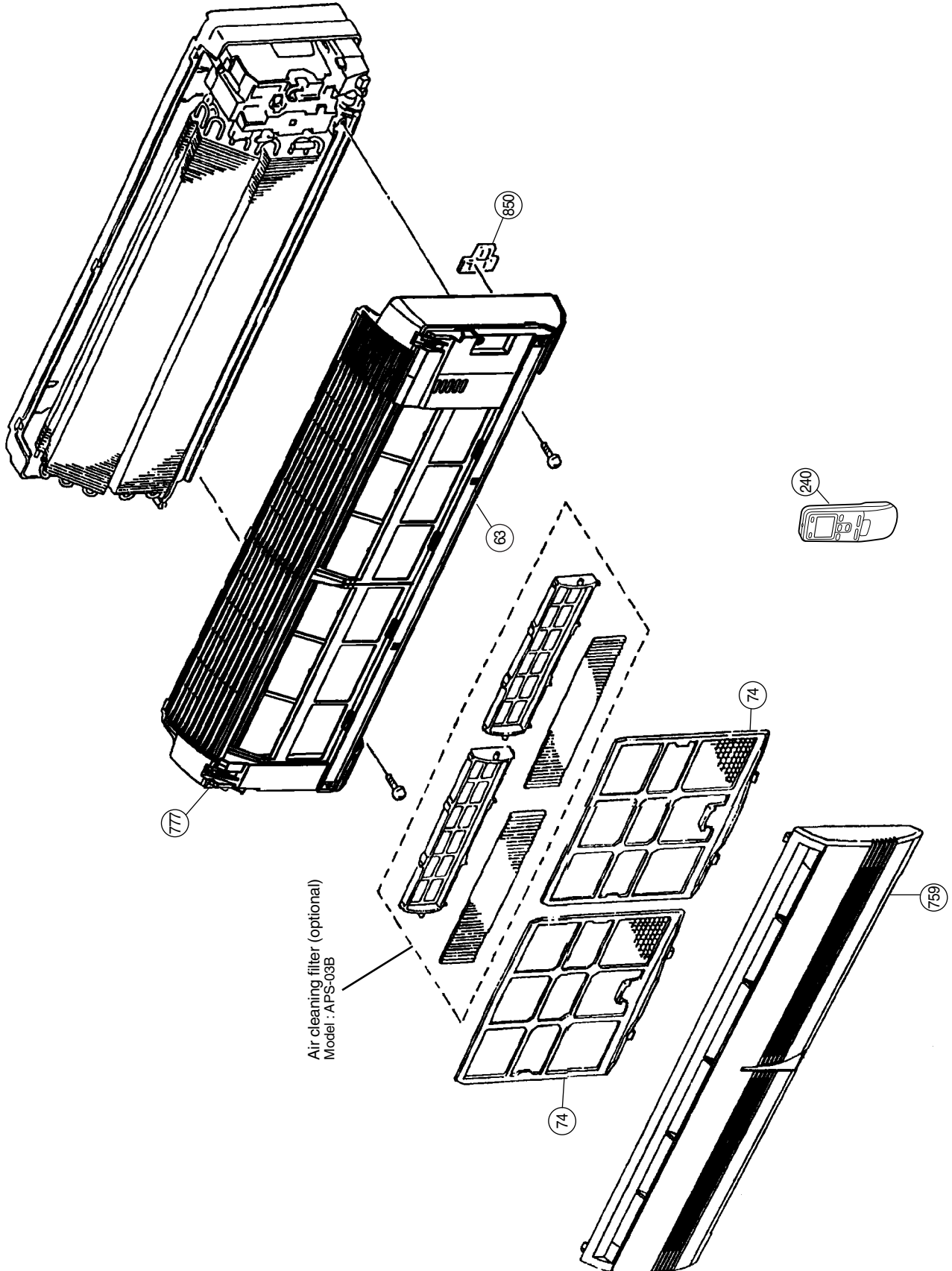

Models : ASY12LMACW
ASY9LMACW
ASY7LMACW

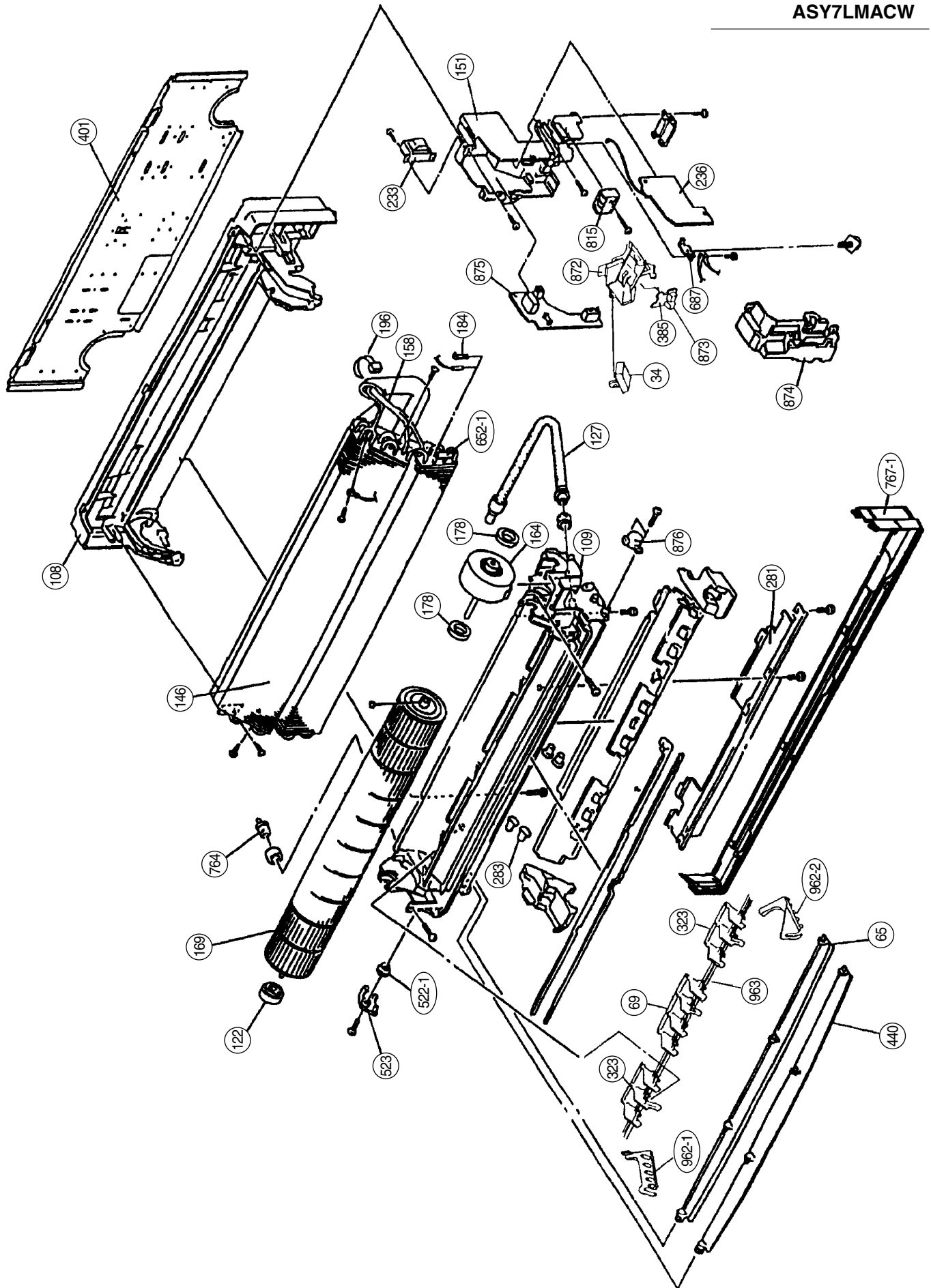

Model : AOY30LMAW4

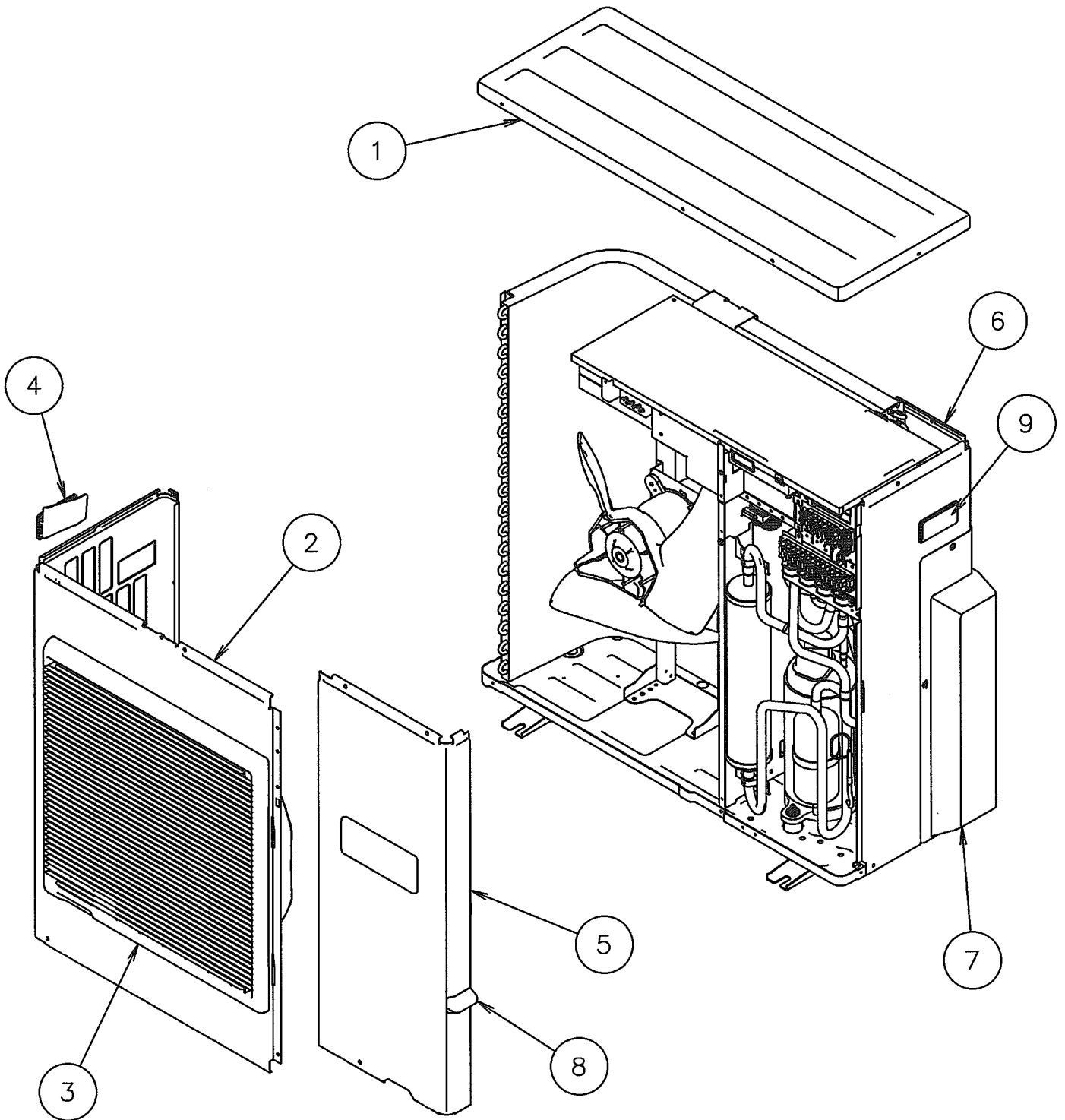

Model : AOY30LMAW4

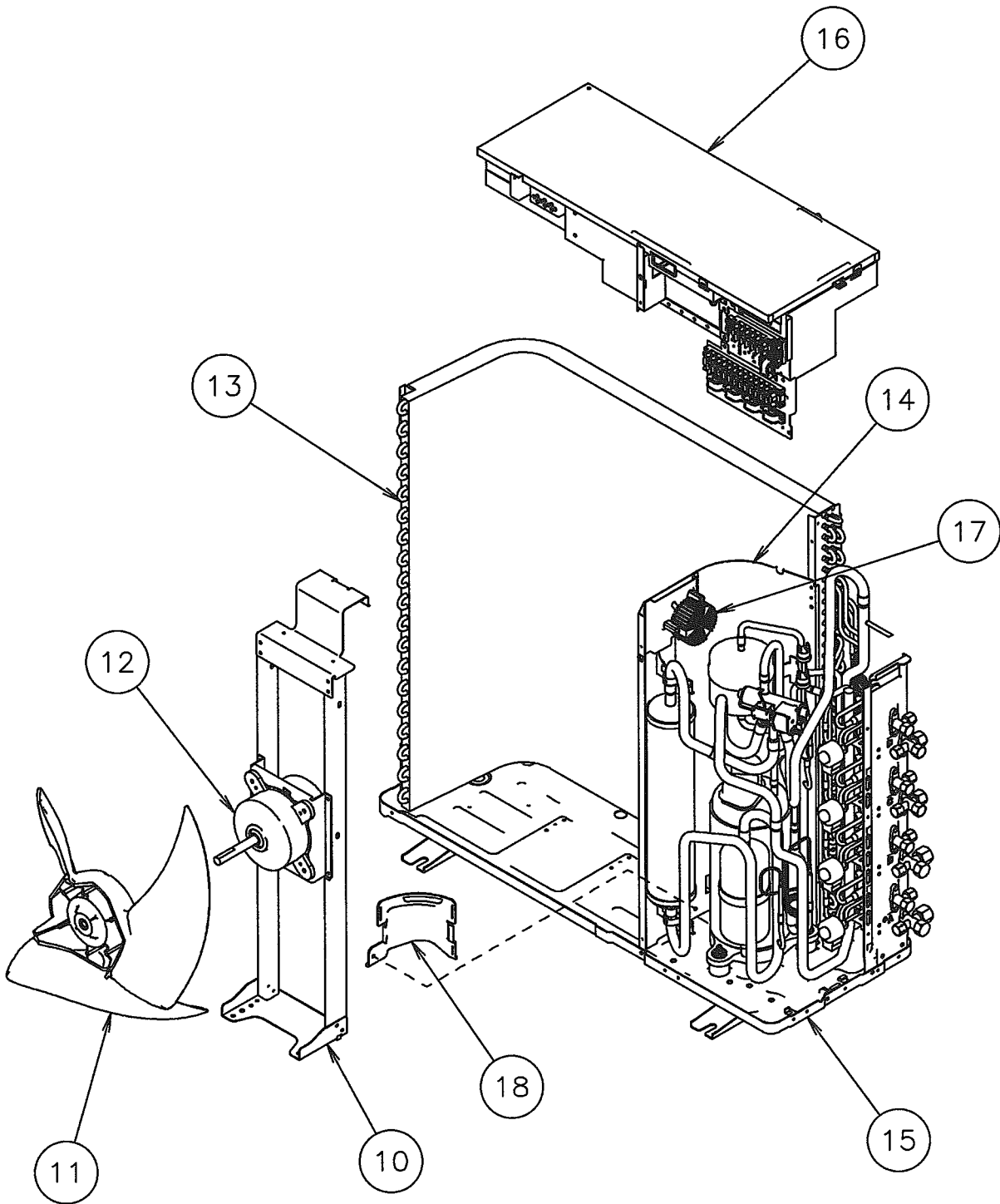

Model : AOY30LMAW4

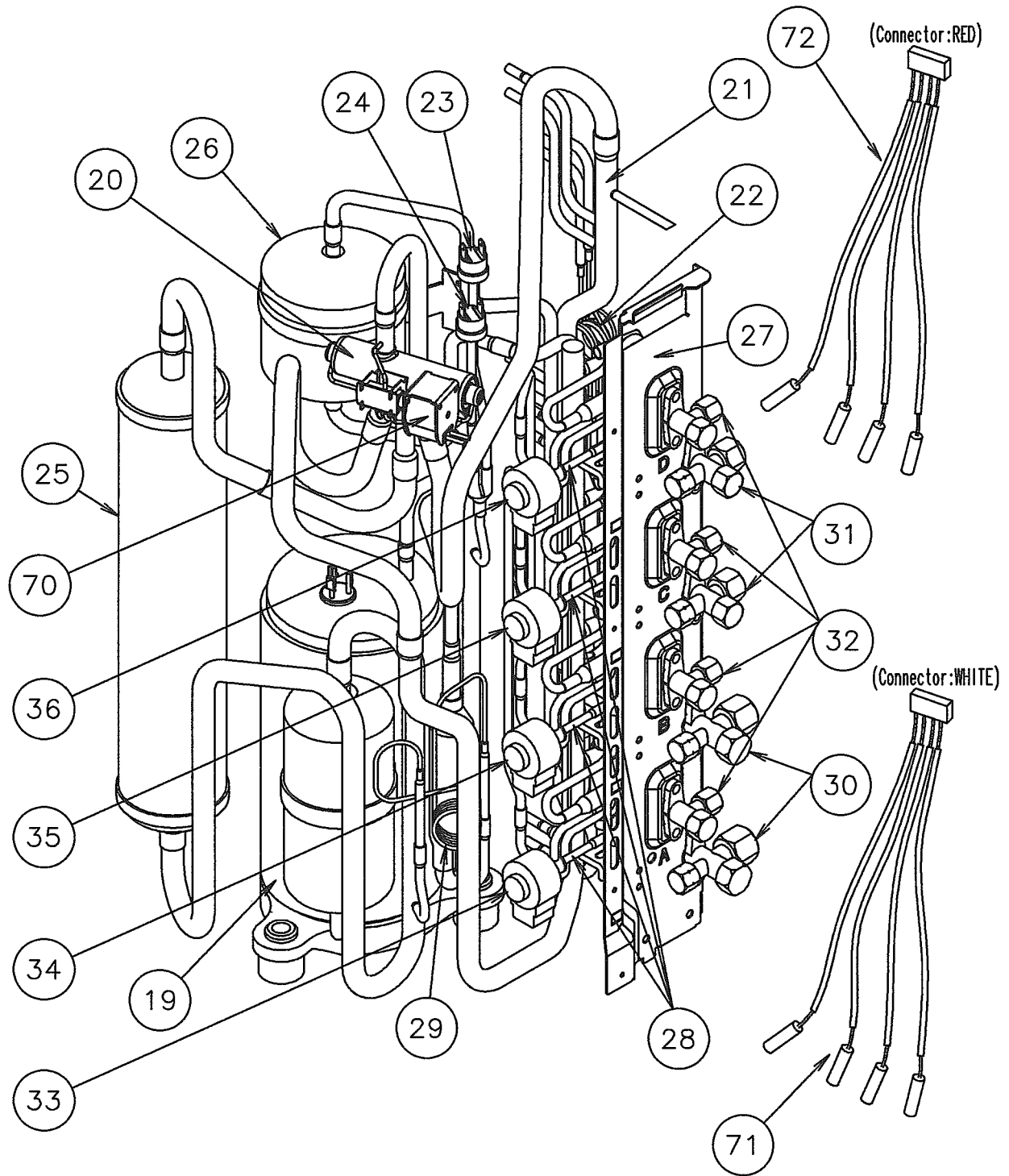

Model : AOY30LMAW4

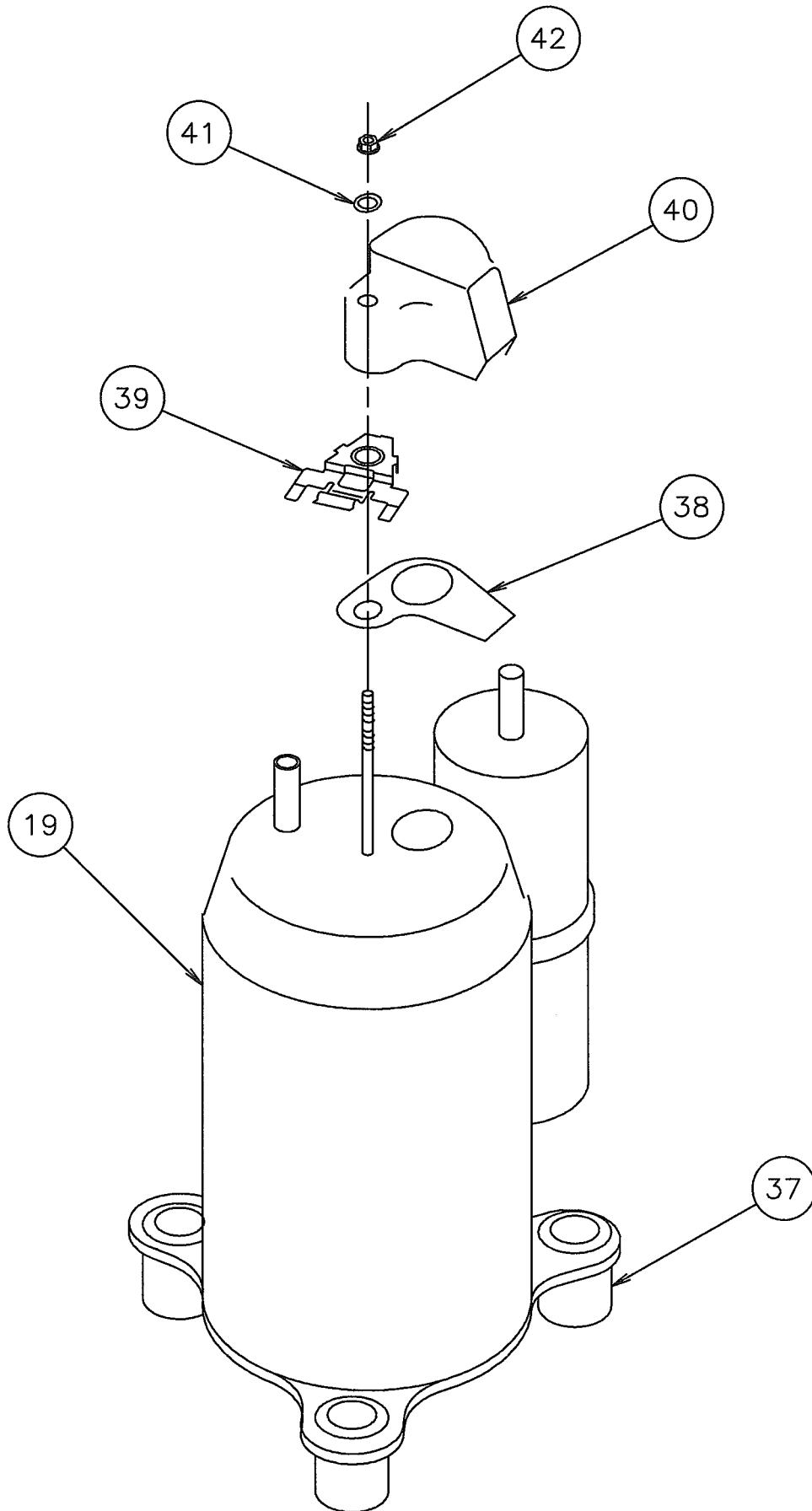

Model : AOY30LMAW4

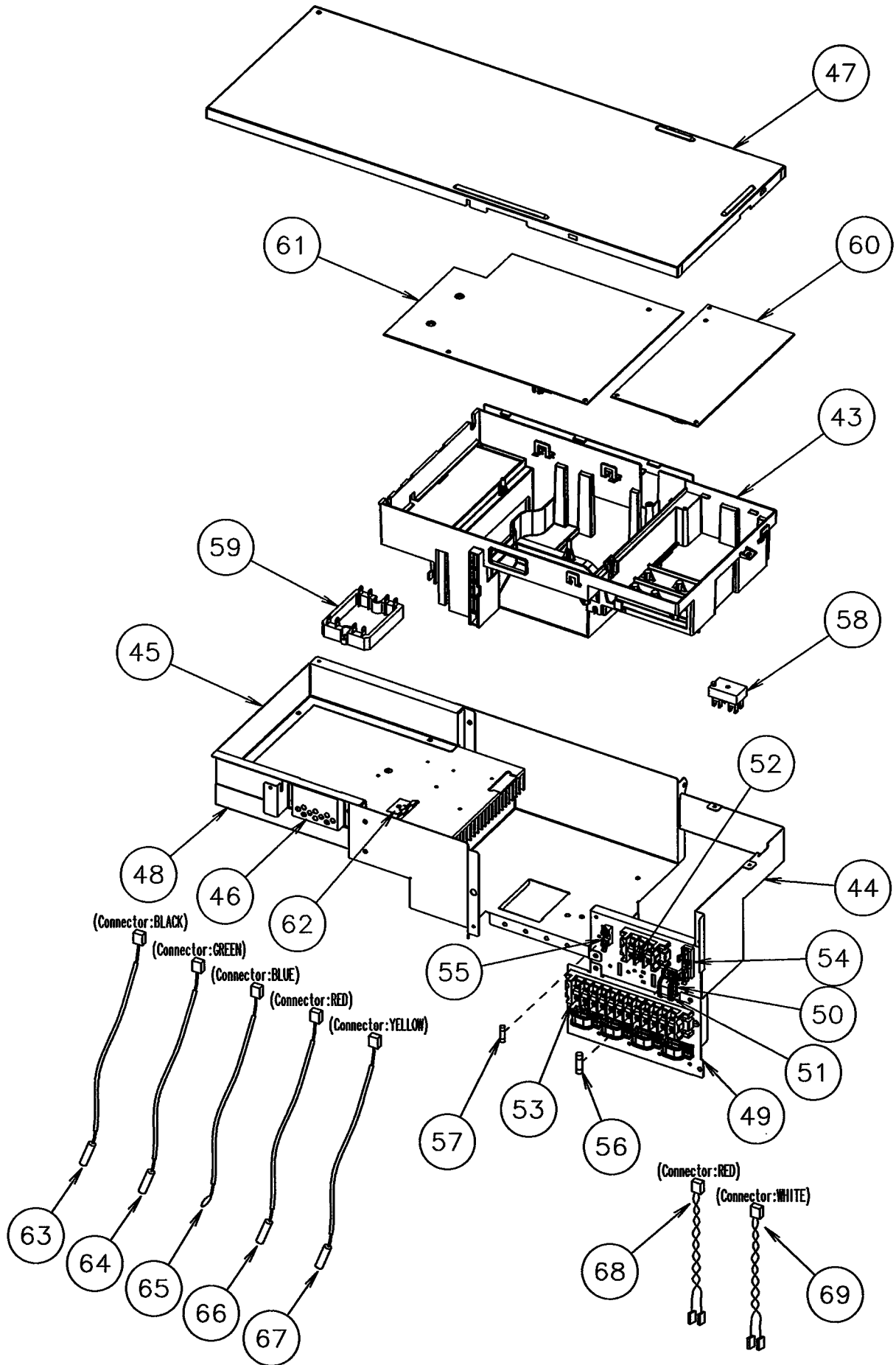

PARTS LIST

INDOOR UNIT

Ref. No.	Description	Part No.			Ord. Q'ty
		ASY7LMACW	ASY9LMACW	ASY12LMACW	
34	Capacitor (Fan motor)	9900089061	9900089061	9900089061	
63	Front Panel Assy	9312417100	9312417100	9312417100	
65	Flow Control Panel-Z	9306058043	9306058043	9306058043	
69	Louver-A	9306055028	9306055028	9306055028	
74	Filter	9305444014	9305444014	9305444014	
108	Base	9309755062	9309755062	9309755062	
109	Casing	9306052027	9306052027	9306052027	
122	Shaft Holder-B	9303066010	9303066010	9303066010	
127	Drain Hose Assy	9305550029	9305550029	9305550029	
146	Evaporator Assy	9308559036	9308559036	9373044017	
151	Control Box	9330007017	9330007017	9330007017	
158	Connecting Pipe Assy	9306416010	9306416010	9306416010	
164	Fan Motor Assy-IN	9601171010	9601171010	9601171010	
169	Cross-Flow Fan Assy	9307836015	9307836015	9307836015	
178	Motor Cushion-M	9601302018	9601302018	9601302018	
184	Thermistor Spring	313728262708	313728262708	313728262708	
196	Clamp SKB-150	313035356905	313035356905	313035356905	
233	Power Transformer	9900028015	9900028015	9900028015	
236	Controller PCB Assy	9705289017	9705289024	9705289031	
240	Remote Control Unit	(EZ-00307HSE-C) 9371190174	(EZ-00308HSE-C) 9371190174	(EZ-00309HSE-C) 9371190174	
281	BRACKET(PIPE)	9330011014	9330011014	9330011014	
283	Bushing-A	9303529010	9303529010	9303529010	
323	Louver-B	9306056025	9306056025	9306056025	
385	Indicator PCB Assy	9705296015	9705296015	9705296015	
401	Wall Hook Bracket	9304358008	9304358008	9304358008	
440	Flow Control Panel-U	9306057046	9306057046	9306057046	
522-1	Gear-A	9306062002	9306062002	9306062002	
523	Gear Bracket	9306407001	9306407001	9306407001	
652-1	Thermistor Holder Pipe	313714262805	313714262805	313714262805	
687	Earth Terminal	313681304205	313681304205	313681304205	
759	Intake Grille	9330001015	9330001015	9330001015	
764	Drain Cap Assy	9304150008	9304150008	9304150008	
767-1	Bottom Cover	9330004016	9330004016	9330004016	
777	CLAMPER(GRILL)	9306755010	9306755010	9306755010	
815	Terminal	9900040055	9900040055	9900040055	
850	Window (Receiver)	9330003019	9330003019	9330003019	
872	Indicator Case	9330009011	9330009011	9330009011	
873	Lamp Cover	9330014015	9330014015	9330014015	
874	Control Box Cover	9330008014	9330008014	9330008014	
875	Power Supply PCB Assy	9705294011	9705294011	9705294011	
876	Step Motor	9900139018	9900139018	9900139018	
962-1	Guard Holder-L	9306678012	9306678012	9306678012	
962-2	Guard Holder-R	9306677015	9306677015	9306677015	
963	Fan Guard	9305751013	9305751013	9305751013	

OUTDOOR UNIT

Ref. No.	Description	Part No.	Ord. Q'ty	Ref. No.	Description	Part No.	Ord. Q'ty
		AOY30LMAW4				AOY30LMAW4	
1	Top Panel Sub Assy	9374417025		41	Washer (Rubber)	9358078006	
2	Front Panel M	9374094066		42	Frang Nut	9358079003	
3	Fan Guard	9374330010		43	Inverter Box A	9374603015	
4	Grip Side	9374173013		44	Inverter Box B Assy	9374625017	
5	Service Panel M	9374093069		45	Inverter Box C	9374605019	
6	Right Panel M	9374599028		46	Inverter Box Duct	9374609017	
7	Valve Cover Sub Assy	9374827015		47	Inverter Box Cover	9374608010	
8	Grip Service	9374171019		48	Heat Sink A	9374607013	
9	Grip	9374172016		49	Inverter Box D	9374606016	
10	Motor Bracket Sub Assy	9374418053		50	Clamp (Cord) C	9359677000	
11	Propeller Fan Assy	9366378020		51	Clamp (Cord)	9356857009	
12	Motor. DC Brushless	9601882015		52	Terminal (3P)	9900203016	
13	Condenser A Assy	9374433056		53	Terminal (12P)	9358660164	
14	Separate Wall Assy S	9374629022		54	Fuse Holder (Big)	0501454012	
15	Base Assy	9374166084		55	Fuse Holder (Small)	0501456016	
16	Inverter Assy	9705824010		56	Fuse (Big)	0600086039	
17	Coil. Choke	9703458019		57	Fuse (Small)	0600376116	
18	Cap Foot	9374345014		58	Terminal	9701971015	
19	Compressor Sub Assy	9374423064		59	ACTPM	9703457012	
20	4-Way Valve Assy	9374425044		60	PWB Assy (Power Supply)	9705647039	
21	Inlet Pipe (Cond) A Assy	9373461067		61	PWB Assy (Controller)	9705642058	
22	Outlet Pipe (Cond) A Assy	9374266067		62	Holder (Thermo)	9372797013	
23	Pressure Switch A Assy	9367726028		63	Heat Sink Thermistor	9900311018	
24	Pressure Switch B Assy	9367727025		64	Compressor Temp Thermistor	9900156022	
25	Accumulator Sub Assy	9374426072		65	Thermistor (Outdoor Temp)	9703516078	
26	Receiver Tank Sub Assy	9373426028		66	Heat Exchanger Thermistor	9704220059	
27	Valve Plate A Assy	9374628025		67	Discharg Temp Thermistor	9704219114	
28	Expansion Valve Assy	9370947106		68	Wire (Pressure Sw)(Red)	9367595037	
29	Capillary Assy	9372197370		69	Wire (Pressure Sw)(White)	9367595044	
30	3-Way Valve Assy (1/2")	9372205051		70	Solenoid	9900165055	
31	3-Way Valve Assy (3/8")	9372205044		71	Thermistor (Pipe)(White)	9900322014	
32	2-Way Valve Assy	9372204054		72	Thermistor (Pipe)(Red)	9900289010	
33	Coil (Expansion Valve)(A=Red)	9900057084					
34	Coil (Expansion Valve)(B=White)	9900057053					
35	Coil (Expansion Valve)(C=Green)	9900057060					
36	Coil (Expansion Valve)(D=Blue)	9900057077					
37	Rubber Seat (For Comp)	9358080009					
38	Gasket	9370290004					
39	Holder	9372066010					
40	Terminal Cover (Comp)	9370289008					

STANDARD ACCESSORIES

INDOOR UNIT

Name and Shape	Part No.
Wall hook bracket 	9304358008
Wall cap-B 	313714296205
Remote control unit 	9371190174 (AR-JW17)
Battery (penlight) 	0600185534
Remote control unit holder 	9305642014
Cloth tape 	9308117007
Tapping screw (big) ($\phi 4 \times 20$) 	301141164200
Tapping screw (small) ($\phi 3 \times 12$) 	0700019036
Air cleaning filter 	DEODORANT FILTER 9310441015 ELECTRIC FILTER 9310442012
Air cleaning filter frame 	9305445011
Adapter D ($1/2'' \rightarrow 3/8''$) $12.7 \text{ mm} \rightarrow 9.52 \text{ mm}$ 	9Q model only 9370244007

0510G2920