

INVERTER MULTI AIR CONDITIONER WALL MOUNTED type

SERVICE MANUAL



Models

Indoor unit

Outdoor unit

ASY7LMACW	}	AOY18LMAK2
ASY9LMACW		
ASY12LMACW		

CONTENTS

SPECIFICATIONS	1
OUTLINE AND DIMENSIONS	2
REFRIGERANT SYSTEM DIAGRAM	3
CIRCUIT DIAGRAM	4
INDOOR PCB CIRCUIT DIAGRAM	6
OUTDOOR PCB CIRCUIT DIAGRAM	7
ERROR CONTENTS	8
DISASSEMBLY ILLUSTRATION	11
PARTS LIST	13
STANDARD ACCESSORIES	15

SPECIFICATIONS

TYPE	COOL & HEAT		
INDOOR UNIT	ASY7LMACW	ASY9LMACW	ASY12LMACW
OUTDOOR UNIT	AOY18LMAK2		

ELECTRICAL DATA (INDOOR UNIT)

COOLING CAPACITY	(kW)	2.2	2.7	3.5
HEATING CAPACITY	(kW)	2.6	3.2	4.0
MOISTURE REMOVAL	(ℓ /hr)	1.0	1.2	1.6
AIR CIRCULATION-Hi	(m³/hr)	430	480	530

ELECTRICAL DATA (OUTDOOR UNIT)

POWER SOURCE	(V)	230		
FREQUENCY	(Hz)	50		
COOLING CAPACITY (MAX)	(kW)	5.5 (6.5)		
HEATING CAPACITY (MAX)	(kW)	6.4 (7.1)		
RUNNING CURRENT (MAX)	(A)	COOLING	7.5 (9.7)	
		HEATING	8.0 (9.7)	
INPUT WATTS (MAX)	(kW)	COOLING	1.73 (2.22)	
		HEATING	1.84 (2.22)	
E.E.R.	(kW / kW)	COOLING	3.18	
		HEATING	3.48	

COMPRESSOR

TYPE	Hermetic type, Inverter, 4 poles, Three phase, DC motor, Rotary		
DISCRIMINATION	TNB 220 FPCM		
REFRIGERANT	R410 A	(g)	1,900

FAN MOTOR

POWER SOURCE	(V)	230			
INDOOR UNIT	DISCRIMINATION	MFA-40GR	MFA-40GR	MFA-40GR	
	HI	(r.p.m.)	1,000	1,200	1,310
	MED	(r.p.m.)	900	1,100	1,260
	LO	(r.p.m.)	850	1,000	1,190
	QUIET	(r.p.m.)	800	940	1,100
OUTDOOR UNIT	(r.p.m.)	780 - 790			

DIMENSIONS

INDOOR UNIT	H x W x D	(mm)	257 x 808 x 187
OUTDOOR UNIT	H x W x D	(mm)	650 x 830 x 320

WEIGHT

INDOOR UNIT	GROSS / NET	(kg)	10 / 8
OUTDOOR UNIT	GROSS / NET	(kg)	62 / 56

NOISE LEVEL

INDOOR UNIT	HI	(dB)	34	36	38
	LO	(dB)	29	29	33
OUTDOOR UNIT	COOLING	(dB)	49		
	HEATING	(dB)	50		

OUTLINE AND DIMENSIONS

Unit : mm

INDOOR UNIT

Models : ASY7LMACW
ASY9LMACW
ASY12LMACW

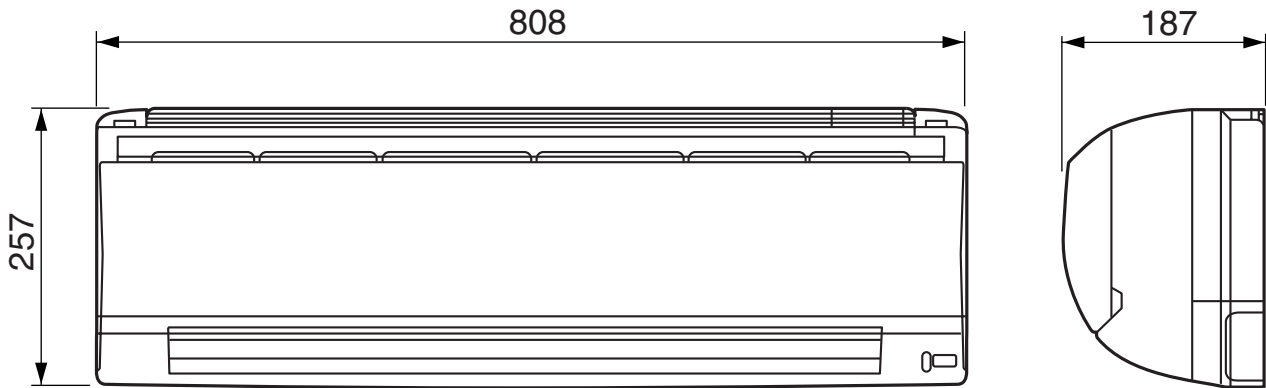

OUTDOOR UNIT

Model : AOY18LMAK2

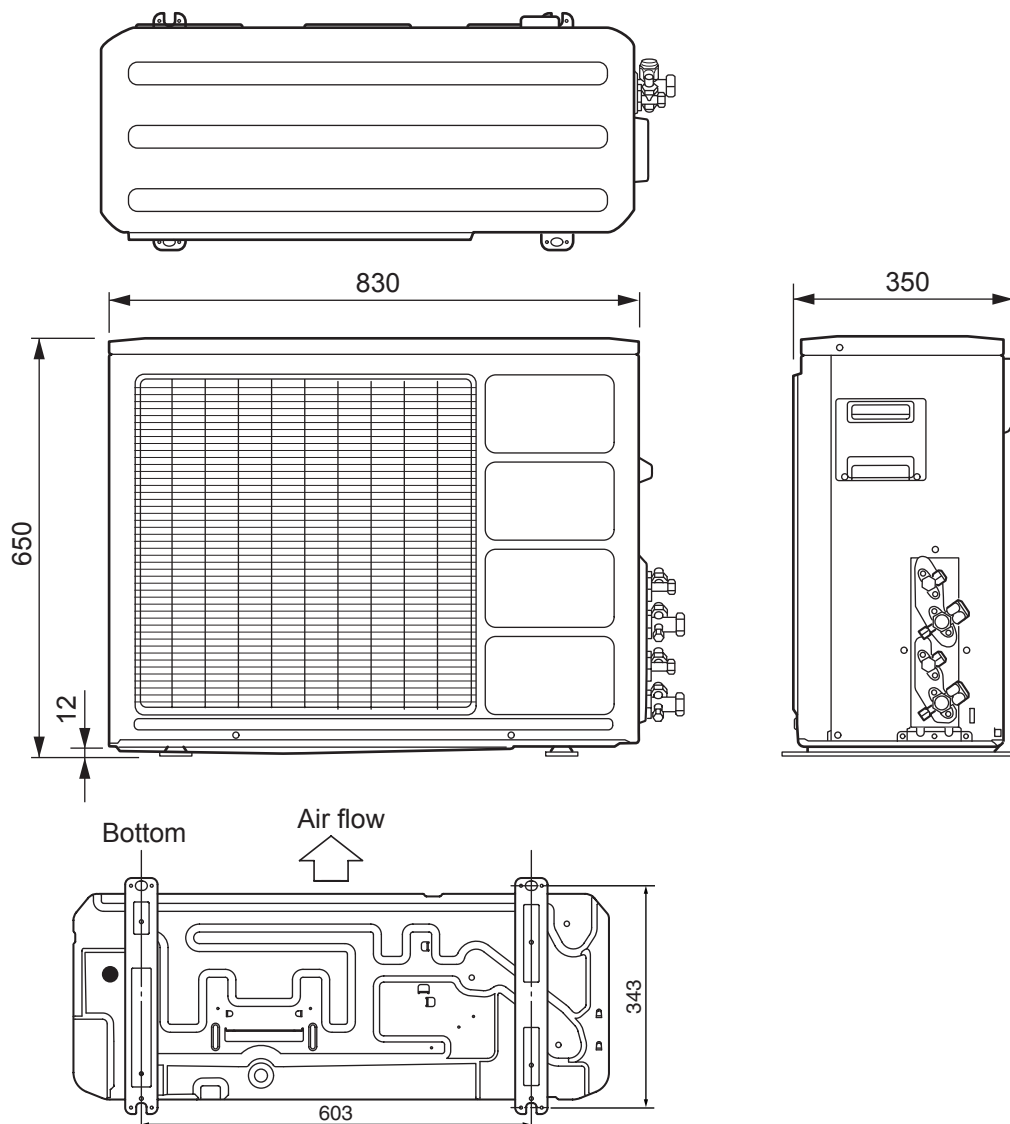

REFRIGERANT SYSTEM DIAGRAM

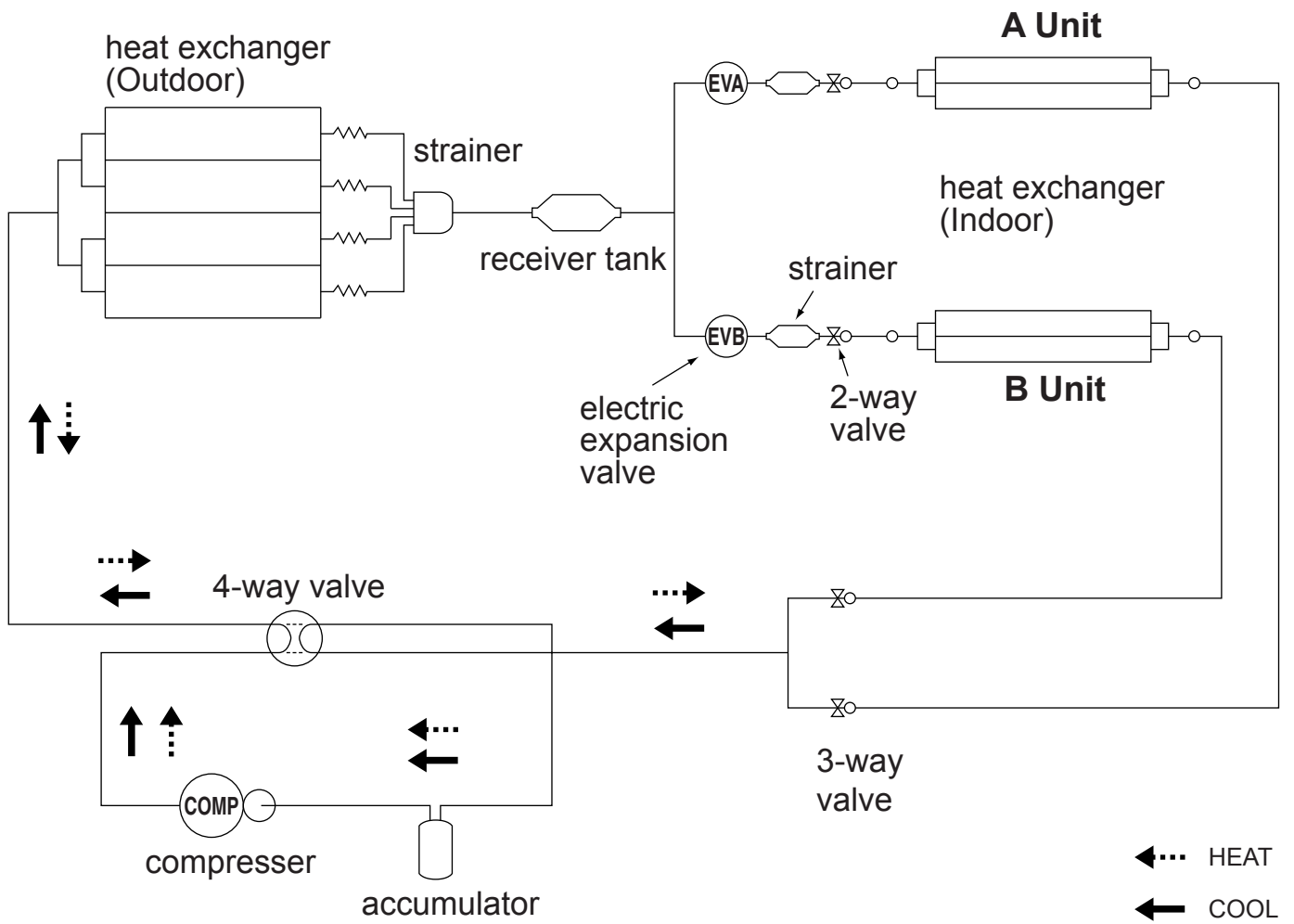

CIRCUIT DIAGRAM

INDOOR UNIT

Models : ASY7LMACW
 ASY9LMACW
 ASY12LMACW

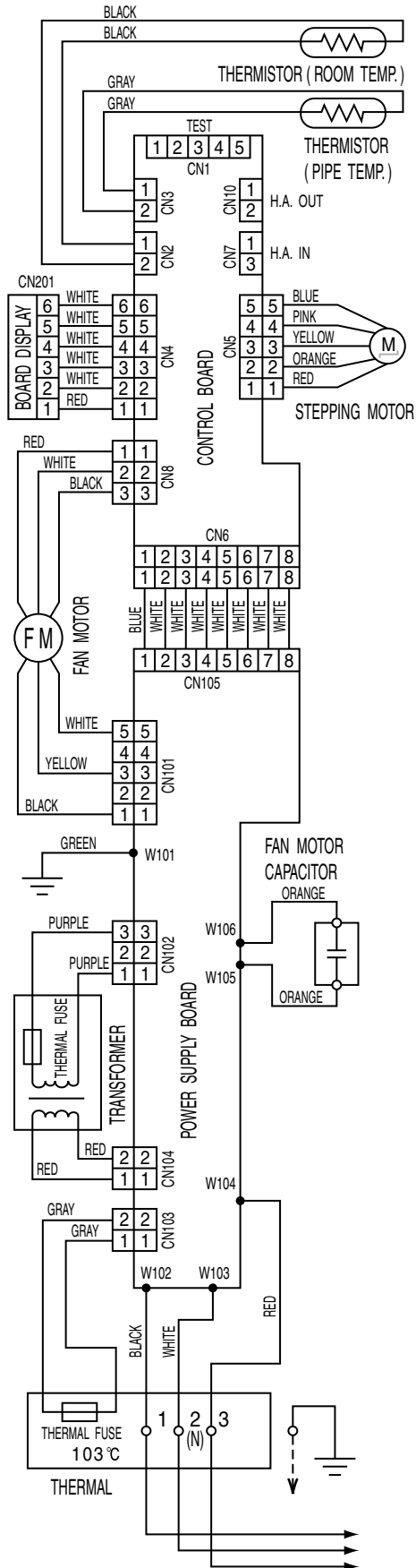

OUTDOOR UNIT

Model : AOY18LMAK2

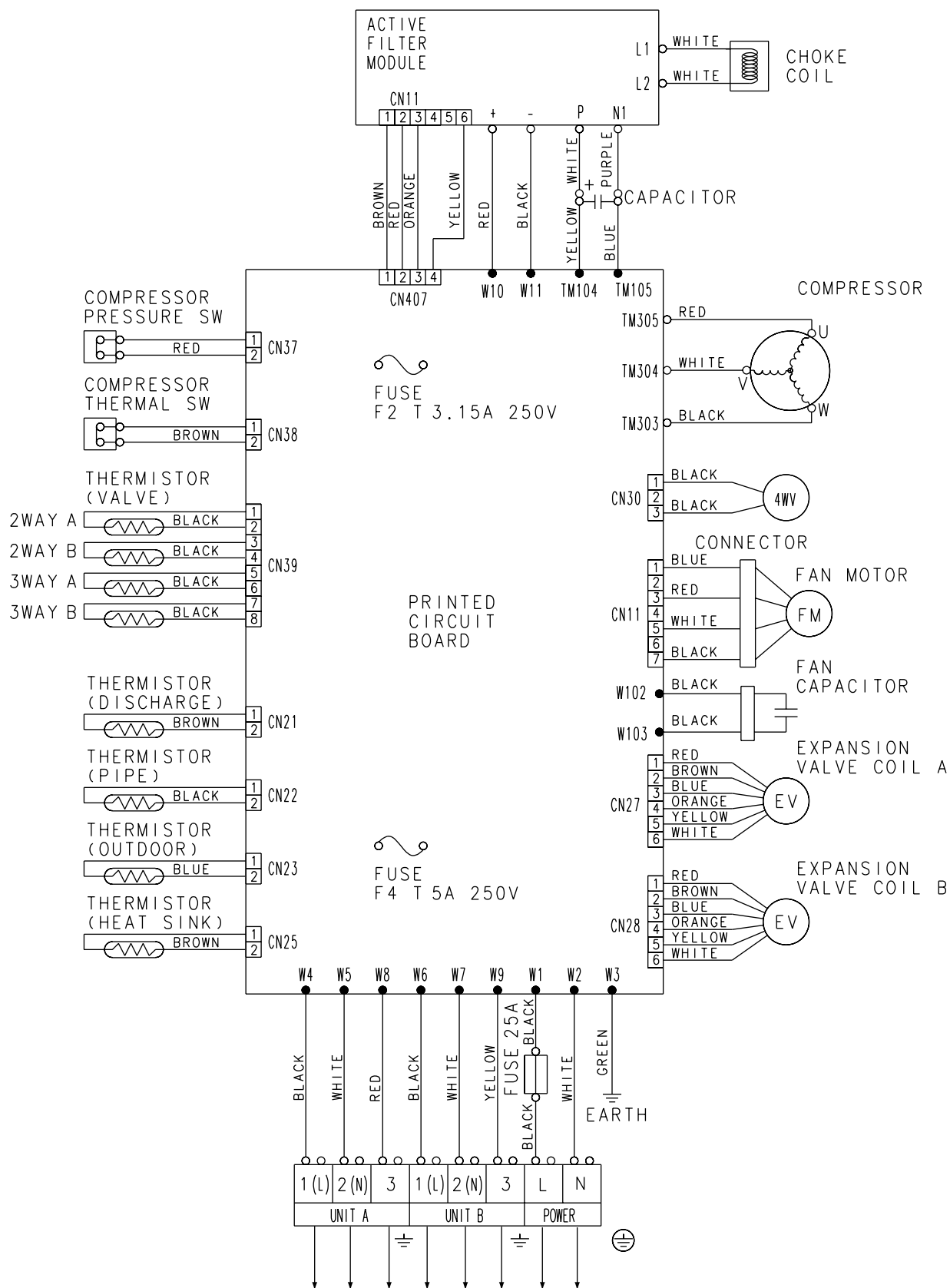

INDOOR PCB CIRCUIT DIAGRAM

Models : ASY7LMACW
ASY9LMACW
ASY12LMACW

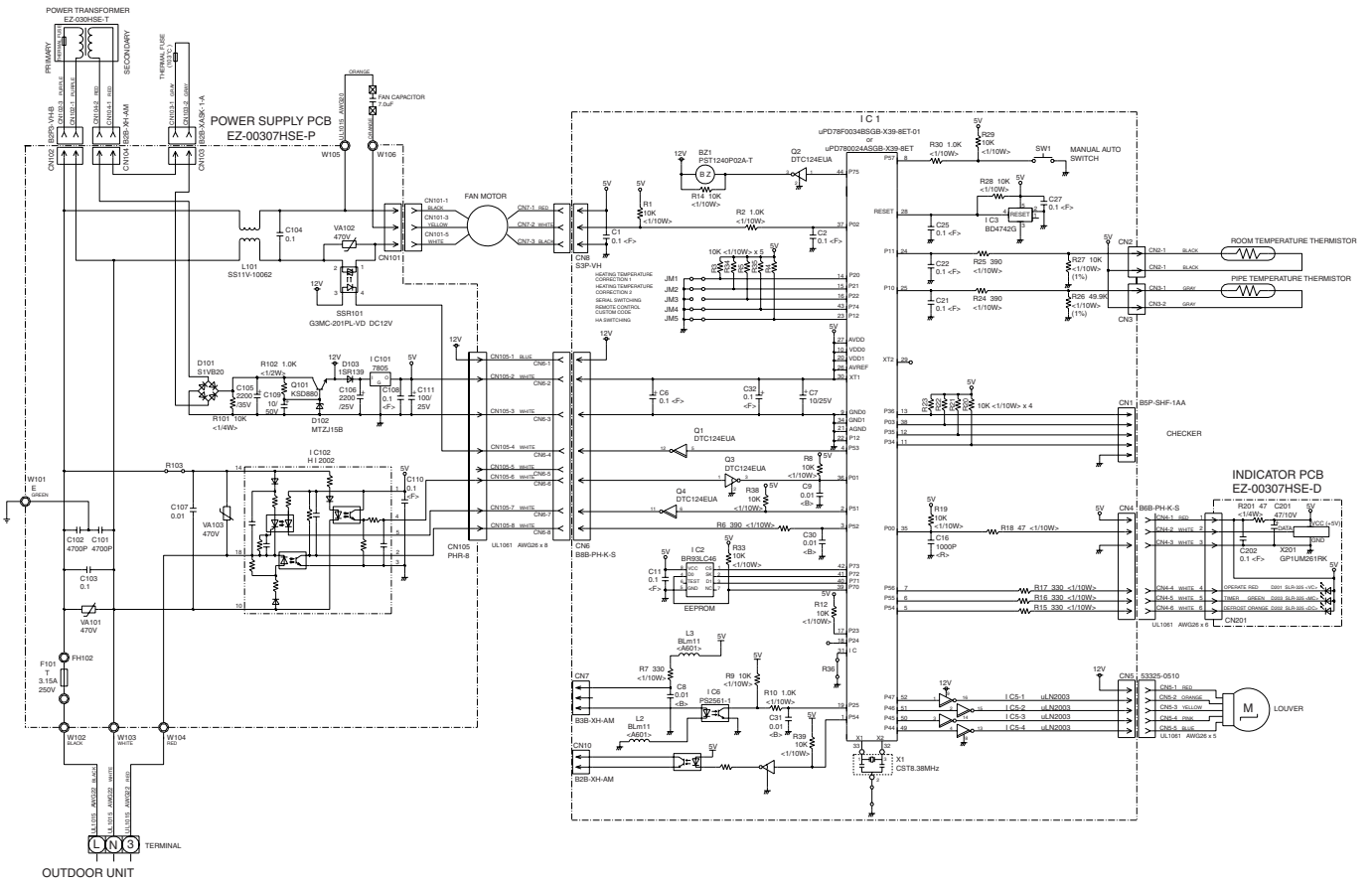

OUTDOOR PCB CIRCUIT DIAGRAM

Model : AOY18LMAK2

CONTROLLER PCB ASSEMBLY (MAIN PCB)
EZ-0037HUE-C

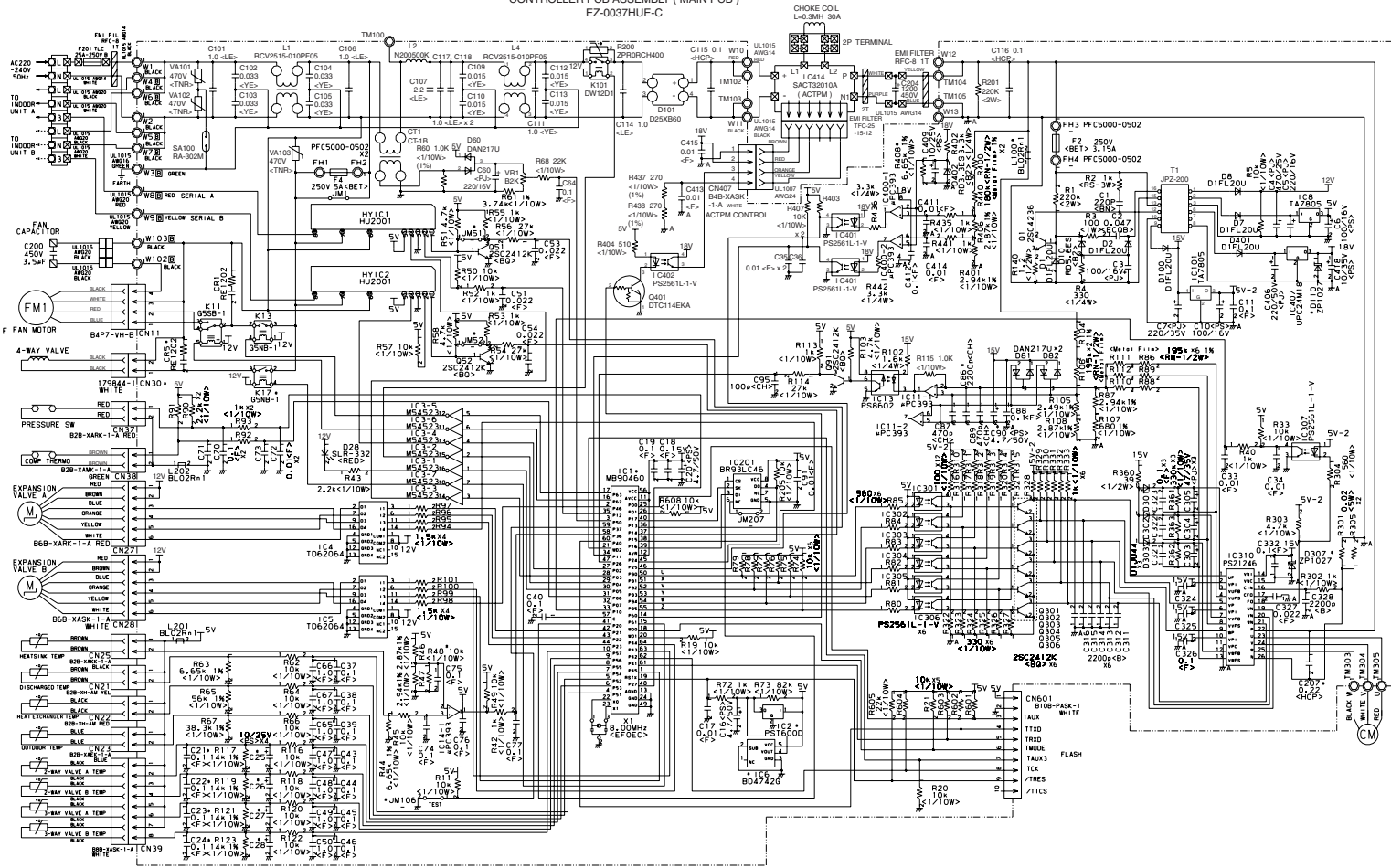

ERROR CONTENTS

○ : Fast flashing ● : Slow flashing

Operation lamp : Red lamp

Timer lamp : Green lamp

INDOOR UNIT

Large division indication			Small division indication		
Error contents	LED indication		Error contents	LED indication	
Thermistor error (indoor unit)	Red lamp Green lamp	● (2 times) ○	Thermistor error (room temp.)	Red lamp	○
			Thermistor error (heat exchanger)	Green lamp	● (2 times)
Control unit error (indoor unit)	Red lamp Green lamp	● (4 times) ○	MANUAL AUTO button error	Red lamp	○
			Power source Hz decision error	Green lamp	● (2 times)
Serial error	Red lamp Green lamp	● (5 times) ○	Serial reverse transmission error	Red lamp	○
			Serial order transmission error	Green lamp	● (2 times)
Fan motor error (indoor unit)	Red lamp Green lamp	● (6 times) ○	Lock error	Red lamp	○
			r.p.m error	Green lamp	● (2 times)
Thermistor error (outdoor unit)	Red lamp Green lamp	○ ● (2 times)	Discharge thermistor error	Red lamp	○
			Heat exchanger thermistor error	Green lamp	● (2 times)
			Outdoor temperature thermistor error	Red lamp	● (4 times)
			Compressor thermistor error	Green lamp	○
			2 way valve thermistor error	Red lamp	● (6 times)
			3 way valve thermistor error	Green lamp	○
Pressure switch error	Red lamp Green lamp	○ ● (3 times)	Pressure switch error	Red lamp	● (2 times)
Control unit error (outdoor unit)	Red lamp Green lamp	○ ● (4 times)	Capacity error of connecting indoor unit	Green lamp	○
			Inverter error	Red lamp Green lamp	○ ● (5 times)
Compressor loter location error	Green lamp	○			
				Red lamp	● (5 times)
				Green lamp	○

When an error occurs, "Large division indication" is indicated first.

Secondly, "Small division indication" is indicated by pushing "Test run" button of remote controller.

DISASSEMBLY ILLUSTRATION

INDOOR UNIT

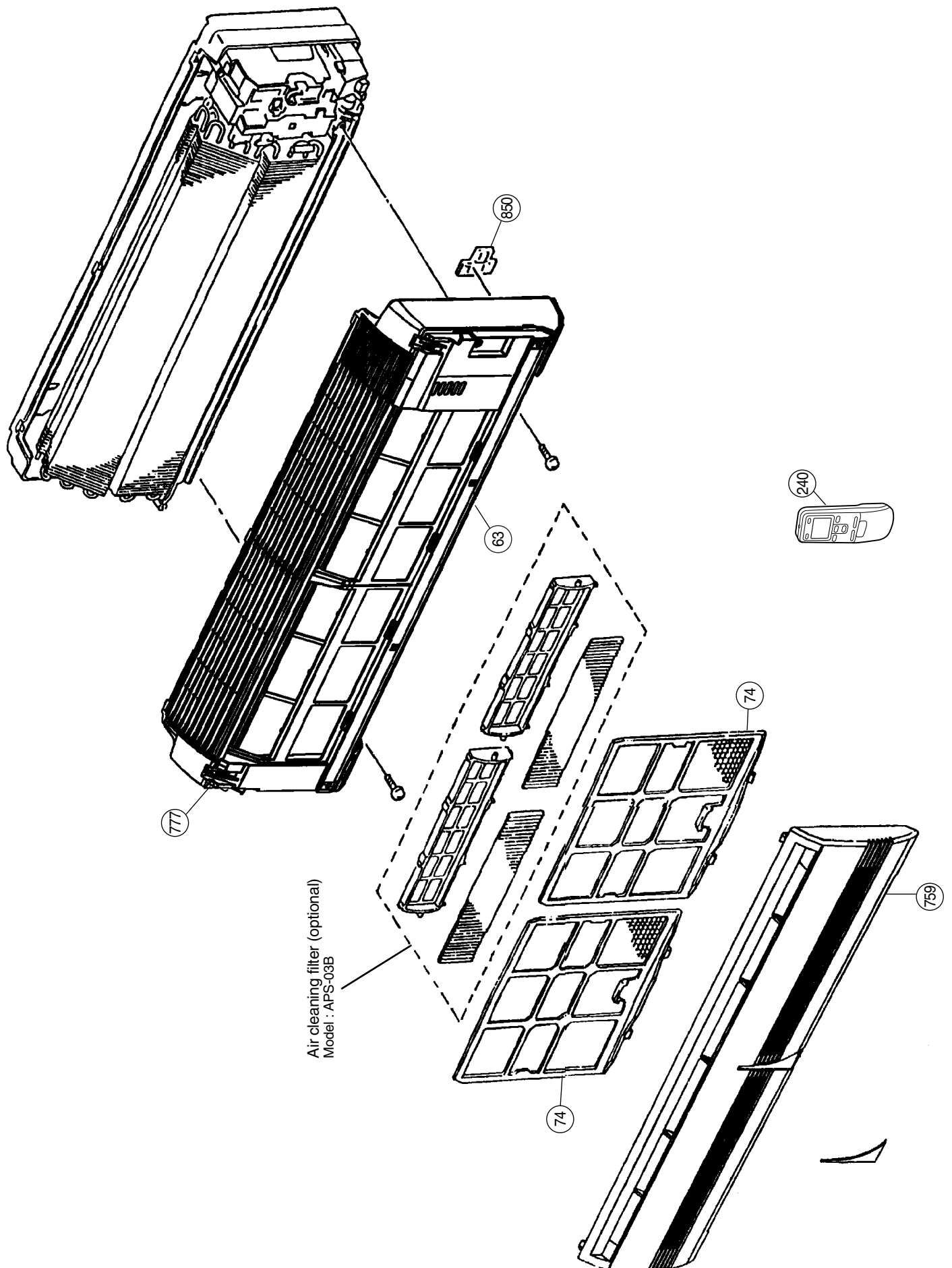

INDOOR UNIT

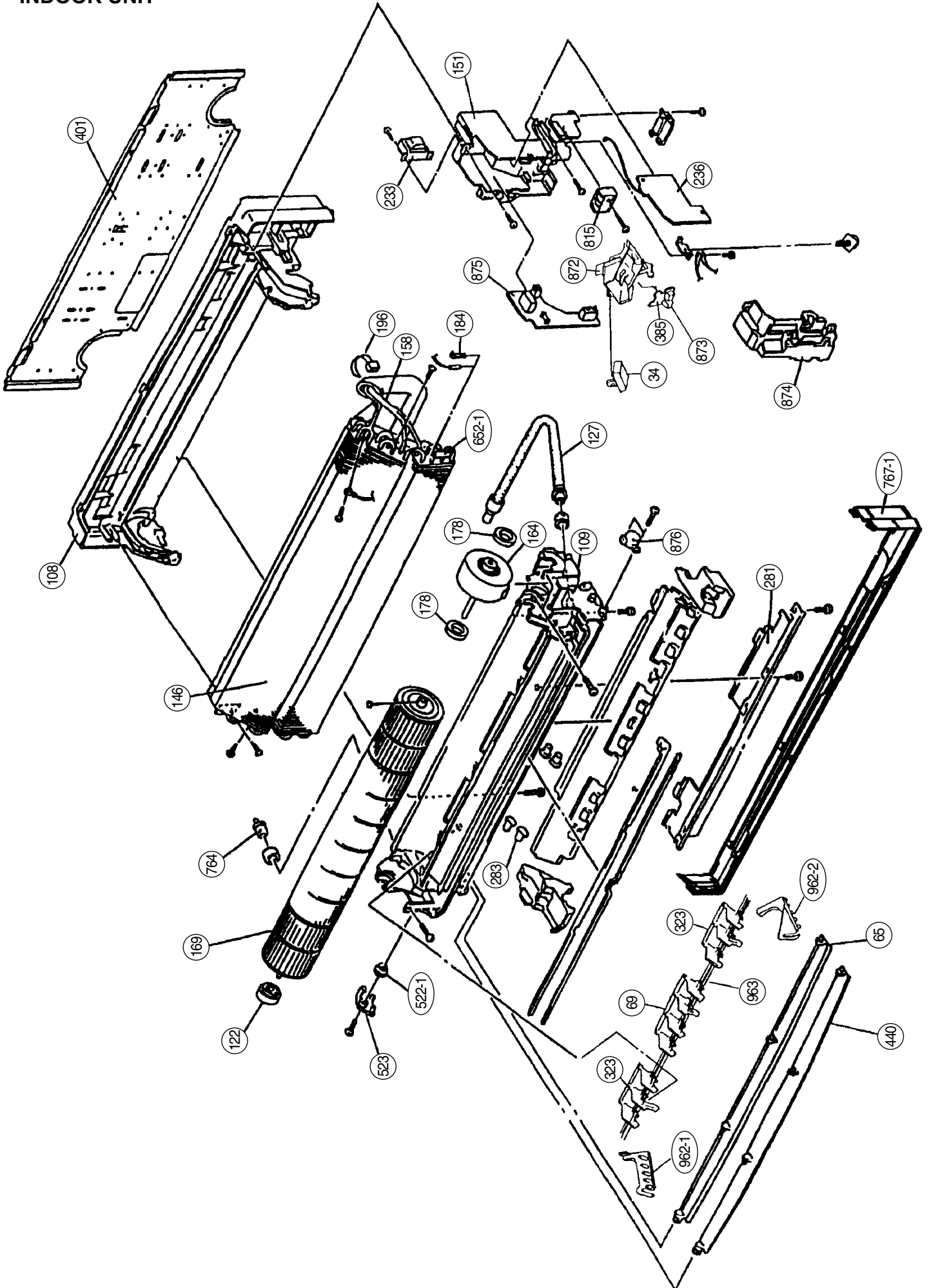

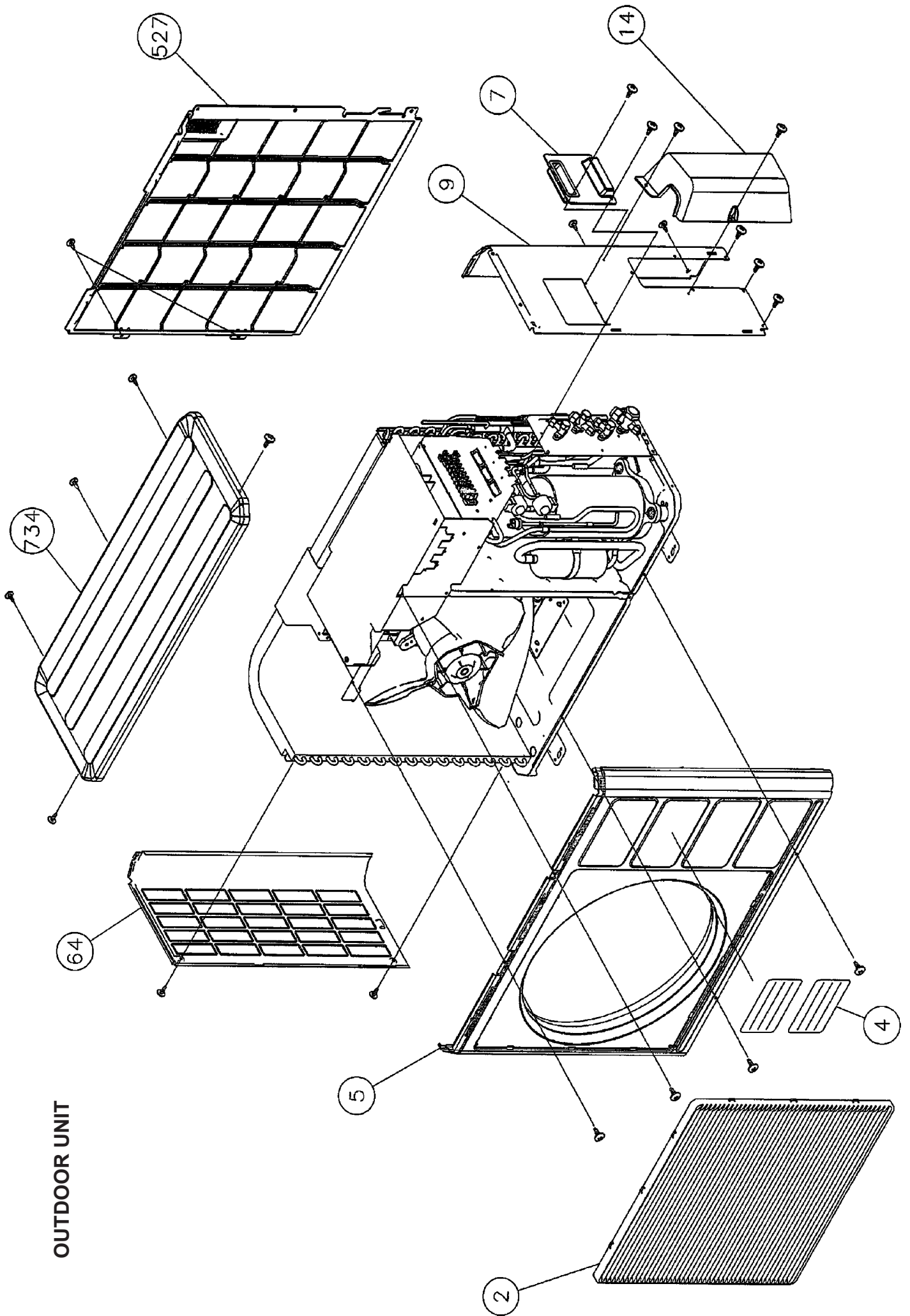

OUTDOOR UNIT

OUTDOOR UNIT

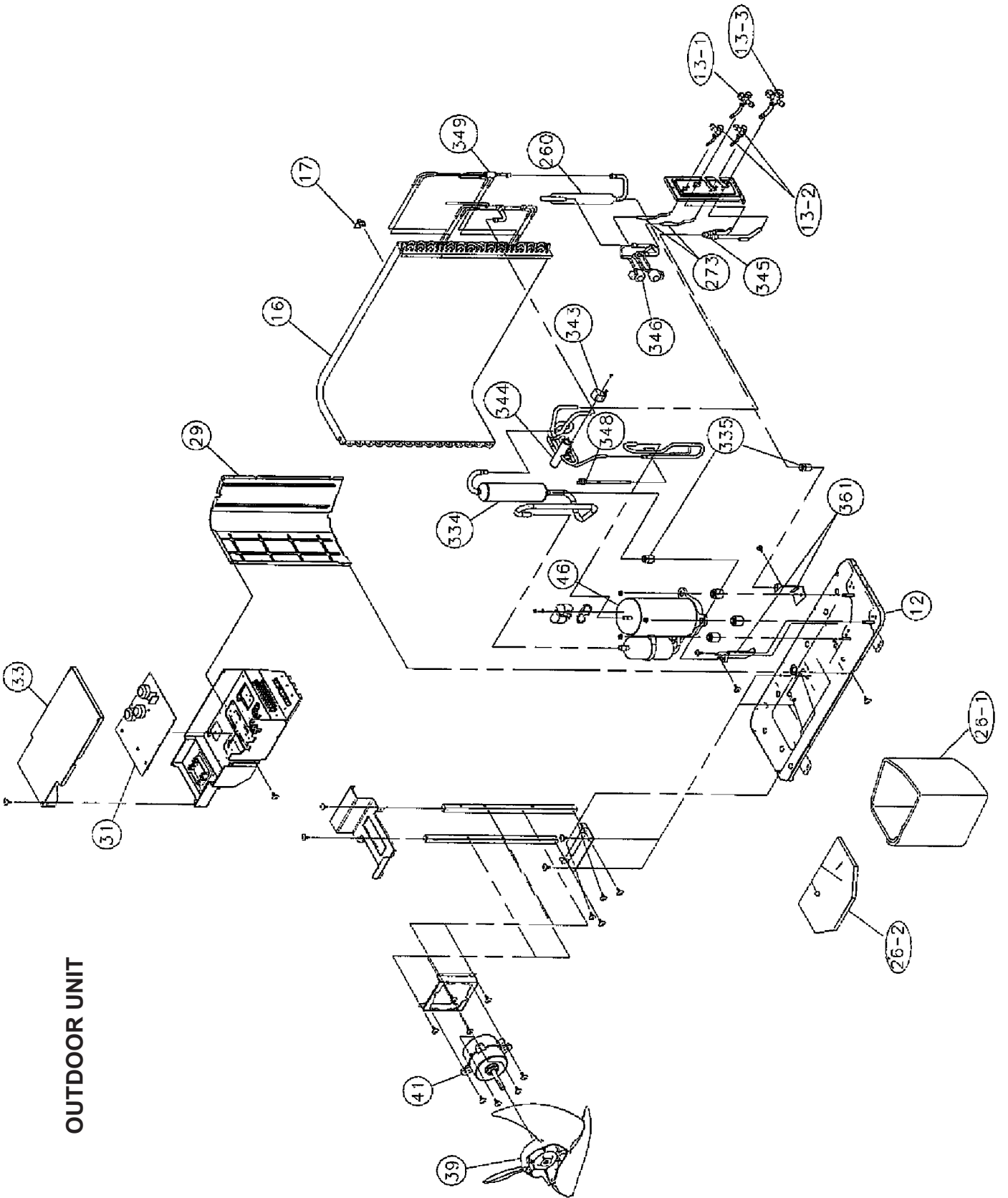

PARTS LIST

INDOOR UNIT

Ref. No.	Description	Part No.			Ord. Q'ty
		ASY7LMACW	ASY9LMACW	ASY12LMACW	
34	Capacitor (Fan motor)	9900089061	9900089061	9900089061	
63	Front Panel Assy	9312417100	9312417100	9312417100	
65	Flow Control Panel-Z	9306058043	9306058043	9306058043	
69	Louver-A	9306055028	9306055028	9306055028	
74	Filter	9305444014	9305444014	9305444014	
108	Base	9309755062	9309755062	9309755062	
109	Casing Assy	9312173037	9312173037	9312173037	
122	Shaft Holder-B	9303066010	9303066010	9303066010	
127	Drain Hose Assy	9305550029	9305550029	9305550029	
146	Evaporator Assy	9308559036	9308559036	9373044017	
151	Control Box	9330007017	9330007017	9330007017	
158	Connecting Pipe Assy	9306416010	9306416010	9306416010	
164	Fan Motor Assy-IN	9601171010	9601171010	9601171010	
169	Cross-Flow Fan Assy	9307836015	9307836015	9307836015	
178	Motor Cushion-M	9601302018	9601302018	9601302018	
184	Thermistor Spring	313728262708	313728262708	313728262708	
196	Clamp SKB-150	313035356905	313035356905	313035356905	
233	Power Transformer	9900028015	9900028015	9900028015	
236	Controller PCB Assy	9705289017	9705289024	9705289031	
240	Remote Control Unit	(EZ-00307HSE-C) 9371190174	(EZ-00308HSE-C) 9371190174	(EZ-00309HSE-C) 9371190174	
281	BRACKET(PIPE)	9330011014	9330011014	9330011014	
283	Bushing-A	9303529010	9303529010	9303529010	
323	Louver-B	9306056025	9306056025	9306056025	
385	Indicator PCB Assy	9705296015	9705296015	9705296015	
401	Wall Hook Bracket	9304358008	9304358008	9304358008	
440	Flow Control Panel-U	9306057046	9306057046	9306057046	
522-1	Gear-A	9306062002	9306062002	9306062002	
523	Gear Bracket	9306407001	9306407001	9306407001	
652-1	Thermistor Holder Pipe	313714262805	313714262805	313714262805	
759	Intake Grille	9330001015	9330001015	9330001015	
764	Drain Cap Assy	9304150008	9304150008	9304150008	
767-1	Bottom Cover	9330004016	9330004016	9330004016	
777	CLAMPER(GRILL)	9306755010	9306755010	9306755010	
815	Terminal	9900040055	9900040055	9900040055	
850	Window (Receiver)	9330003019	9330003019	9330003019	
872	Indicator Case	9330009011	9330009011	9330009011	
873	Lamp Cover	9330014015	9330014015	9330014015	
874	Control Box Cover	9330008014	9330008014	9330008014	
875	Power Supply PCB Assy	9705294011	9705294011	9705294011	
876	Step Motor	9900139018	9900139018	9900139018	
962-1	Guard Holder-L	9306678012	9306678012	9306678012	
962-2	Guard Holder-R	9306677015	9306677015	9306677015	
963	Fan Guard	9305751013	9305751013	9305751013	

OUTDOOR UNIT







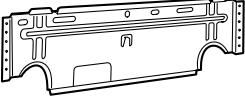

Ref. No.	Description	Part No.	Ord. Q'ty	Ref. No.	Description	Part No.	Ord. Q'ty
		AOY18LMAK2				AOY18LMAK2	
2	Fan Guard	9371187013		64	Side Panel L	9371926018	
4	Emblem	9351355005		260	Receiver Tank Assy	9373426011	
5	Front Panel	9371924014		273	Strainer Assy	9366602019	
7	Connecteur Cover (Cabinet)	9366398004		334	Accumulator	9368391003	
9	Side Panel R	9371927015		335	Accumulator Holder Rubber	9354022010	
12	Base Assy	9371920078		343	Solenoid	9900165079	
13-1	3-Way Valve	9372205044		344	4-Way Valve	9900163013	
13-2	2-Way Valve	9372204054		345	Joint Pipe (3Way) Assy	9373729129	
13-3	3-Way Valve	9372205051		346	Expansion Valve Assy	9373729068	
14	Valve Cover	9372796016		348	Pressur Switch Assy	9373729044	
16	Condenser Assy	9372181096		349	Capillary Assy	9373729211	
17	Thermister Holder Pipe	313714262805		361	Accum Support Assy	9372252017	
26-1	Compressor Cover A	9373730019		527	Protective Net	9371934013	
26-2	Compressor Cover B	9373730026		734	Top Plate	9371925011	
29	Separate Wall	9372795019		---	Condenser Sub Assy	9372313121	
33	Control Cover	9372792018		---	Relay	9900117016	
34	Capacitor, Plastic	9704305077		---	Compressor pressure switch	9900186012	
39	Propeller Fan Assy	9366378013		---	Compressor thermal switch	9373263012	
41	Motor Induct	9601671046		---	Thermistor Valve	9900194017	
46	Compressor Assy	9373262015		---	Thermistor discharge	9704219039	
				---	Heat exchanger thermistor	9704220059	
				---	Thermistor outdoor	9703516047	
				---	Thermistor heat sink	9900195014	

Inverter Assy

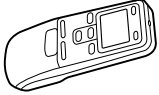

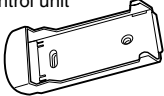
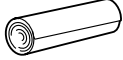
Ref. No.	Description	Part No.	Ord. Q'ty
31	Controllor PCB Assy	9705285057 (K03AV-0500HUE-C1)	
---	ACTPM	9703457012	
---	Capacitor, Elec	9705387010	
---	Capacitor, Plastic	9704305077	
---	Fuse	0600086039	
---	Terminal 8P	9900203047	
---	Fuse Holder	0501454012	
---	Terminal 2P	9701971015	

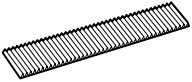
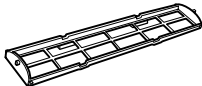
STANDARD ACCESSORIES

INDOOR UNIT ACCESSORIES

Name and Shape	Part No.
Wall hook bracket 	9304358008
Wall cap-B 	313714296205
Remote control unit 	9371190174 (AR-JW17)
Battery (penlight) 	0600185534
Remote control unit holder 	9305642014
Cloth tape 	9308117007
Tapping screw (big) ($\phi 4 \times 20$) 	301141164200
Tapping screw (small) ($\phi 3 \times 12$) 	0700019036
Air cleaning filter 	DEODRANT FILTER 9310441015 ELECTRIC FILTER 9310442012
Air cleaning filter frame 	9305445011
Adapter D (1/2" → 3/8") 12.7 mm → 9.52 mm 	9L model only 9370244007

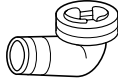
OUTDOOR UNIT ACCESSORIES

Name and Shape	Part No.
Drain pipe 	9303029015
Drain cap 	313166024302
Adapter D (1/2" → 3/8") 12.7mm → 9.52mm 	9370244007

0506G2871