



INSTALLATION MANUAL

Refrigerant
R407C **Duct Type**

SPLIT TYPE AIR CONDITIONER (PART NO. 9363065015)

This air conditioner uses new refrigerant HFC (R407C).

For authorized service personnel only.

 WARNING!	This mark indicates procedures which, if improperly performed, might lead to the death or serious injury of the user.
 CAUTION!	This mark indicates procedures which, if improperly performed, might possibly result in personal harm to the user, or damage to property.









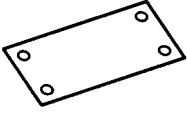

WARNING

- (1) For the air conditioner to operate satisfactorily, install it as outlined in this installation manual.
- (2) Connect the indoor unit and outdoor unit with the room air conditioner piping and cords available from our standard parts. This installation manual describes the correct connections using the installation set available from our standard parts.
- (3) Installation work must be performed in accordance with national wiring standards by authorized personnel only.
- (4) If refrigerant leaks while work is being carried out, ventilate the area. If the refrigerant comes in contact with a flame, it produces a toxic gas.
- (5) Do not turn on the power until all installation work is complete.

- Be careful not to scratch the air conditioner when handling it.
- After installation, explain correct operation to the customer, using the operating manual.
- Let the customer keep this installation manual because it is used when the air conditioner is serviced or moved.

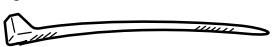
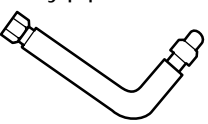
STANDARD PARTS

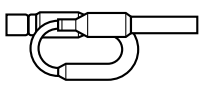
The following installation parts are furnished. Use them as required.

INDOOR UNIT ACCESSORIES		
Name and Shape	Q'ty	Application
Installation template 	1	For positioning the indoor unit
Hanger 	4	For suspending the indoor unit from ceiling
Special nut A (large flange) 	4	For suspending the indoor unit from ceiling
Special nut B (small flange) 	4	
Coupler heat insulation (large) 	2	For indoor side pipe joint (large pipe)
Coupler heat insulation (small) 	1	For indoor side pipe joint (small pipe)
Nylon fastener 	1	For fixing the drain hose
Auxiliary pipe assembly 	1	For wiring conduit (gas side) connection
Drain hose insulation 	1	Insulates the drain hose and vinyl hose connection
Indoor capillary tube 	1	(This part is enclosed with the 30,000 and 36,000 • 25,000 BTU/h versions.)
BR sheet 	2	65 x 130 x T5 (This part is enclosed with the 30,000 and 36,000 • 25,000 BTU/h versions.)

SELECTING THE MOUNTING POSITION

Decide the mounting position with the customer as follows:

INDOOR UNIT

- (1) Install the indoor unit on a place having a sufficient strength so that it withstand against the weight of the indoor unit.
- (2) The inlet and outlet ports should not be obstructed; the air should be able to blow all over the room.
- (3) Leave the space required to service the air conditioner (Fig. 1).

Fig. 1

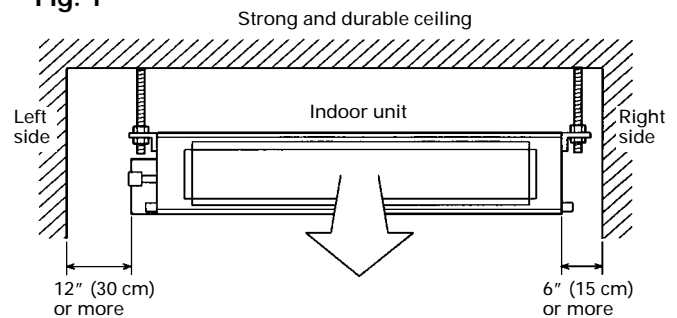

- (4) Install the unit where the drain pipe can be easily installed.
- (5) Providing as much space as possible between the indoor unit and the ceiling will make work much easier.

CONNECTION PIPE REQUIREMENT

Table 1

	Diameter	
	Small	Large
45,000 BTU/h class	9.53 mm	19.05 mm
36,000 BTU/h class	9.53 mm	19.05 mm
30,000 BTU/h class	9.53 mm	15.88 mm
25,000 BTU/h class	9.53 mm	15.88 mm

- Use 0.7 mm to 1.2 mm thick pipe.
- Use pipe with water-resistant heat insulation.
- Use pipe that can withstand a pressure of 3,040 kPa.

ELECTRICAL REQUIREMENT

Table 2

Connection cord (mm ²)	MAX	2.5
	MIN	1.5

- Always use H07RN-F or equivalent as the connection cord.
- Install the disconnection device with a contact gap of at least 3 mm nearby the units. (Both indoor unit and outdoor unit)

INSTALLATION PROCEDURE

Install the air conditioner as follows:

1. INDOOR UNIT INSTALLATION

1. PIPING CONNECTION DIRECTION AND PREPARATION

- Select piping directions (Fig. 2).

Fig. 2

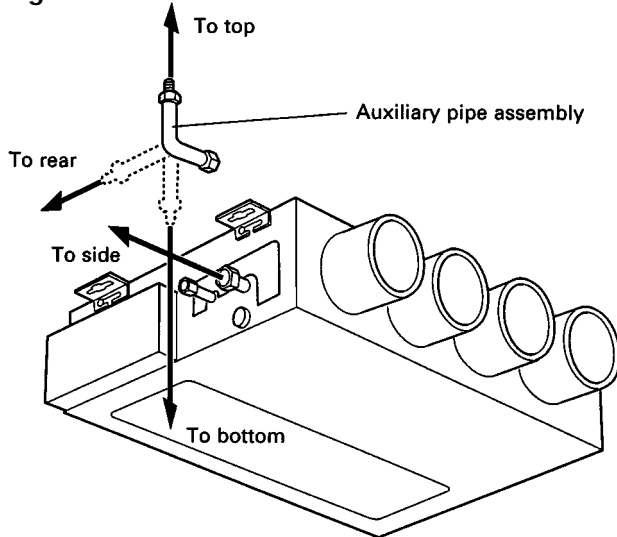

- When bending the piping is difficult, use the auxiliary pipe assembly.

2. DRILLING HOLES FOR BOLTS AND INSTALLING THE BOLTS

- Using the installation template, drill holes for bolts (four holes) (Fig. 3).

Fig. 3

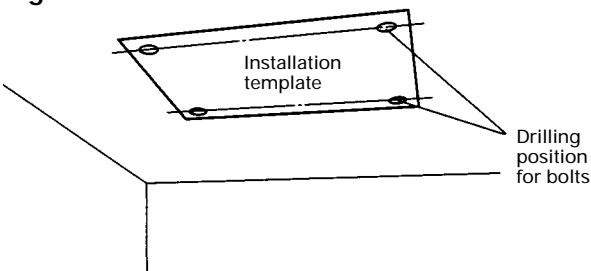

3. INSTALLING THE HANGERS

Installation method (1)

- Fasten the hanging bolts to the ceiling and install special nuts A and B.

Fig. 4

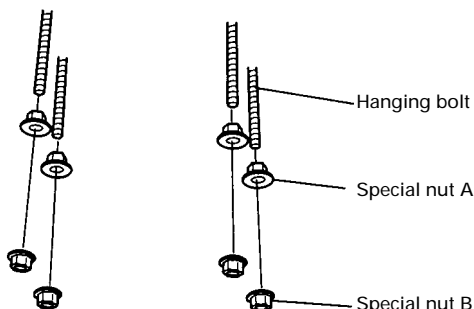

- Install the hangers to the unit.

Fig. 5

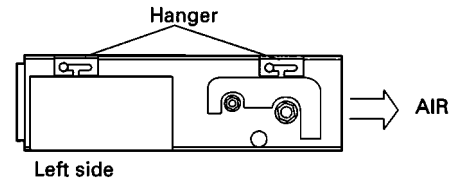

CAUTION

When fastening the hangers, make the bolt positions uniform.

(Example)

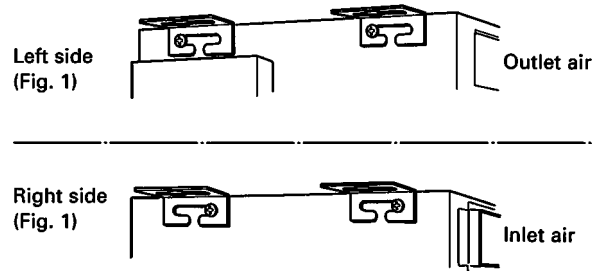

- Hang the unit.

- (1) Pass the hanging bolts through the hangers. (Four places)

Fig. 6

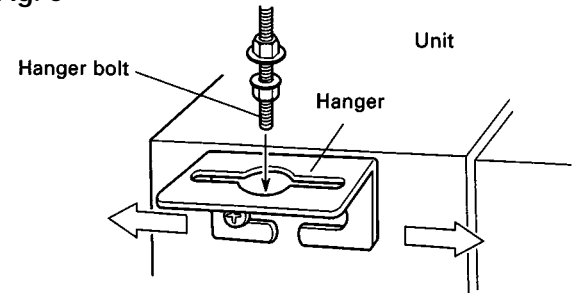

- (2) Slide the unit in the arrow direction and fasten it.

Fig. 7

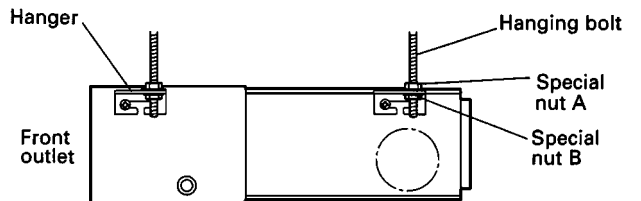

CAUTION

Fasten the unit securely with special nuts A and B.

Installation method (2)

- Install the bolts to the ceiling at a place strong enough to hang the unit. Mark the bolt positions from the installation template.

With a concrete drill, drill for 1/2" (12.7 mm) dia. holes (Fig. 8).

Fig. 8

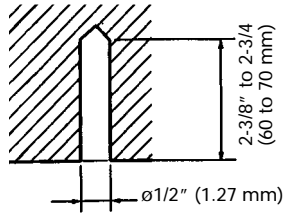

- Insert the anchor bolts into the drilled holes, and drive the pins completely into the anchor bolts with a hammer.

Fig. 9

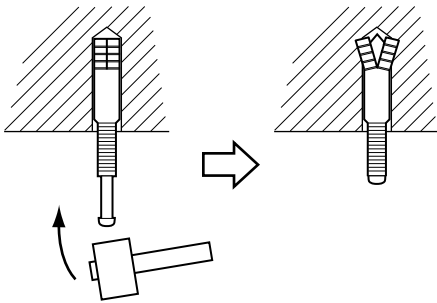

- Install the hangers to the unit.

Fig. 10

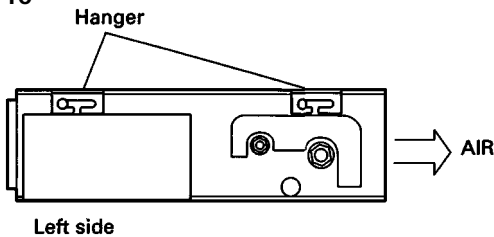

CAUTION
When fastening the hangers, make the bolt positions uniform.

(Example)

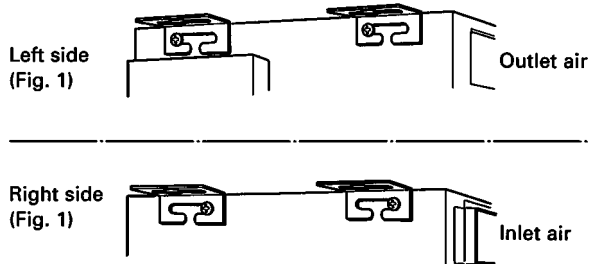

- Install the unit
Pass the unit hangers over the bolts installed to the ceiling and install the unit with the special nut B.

Fig. 11

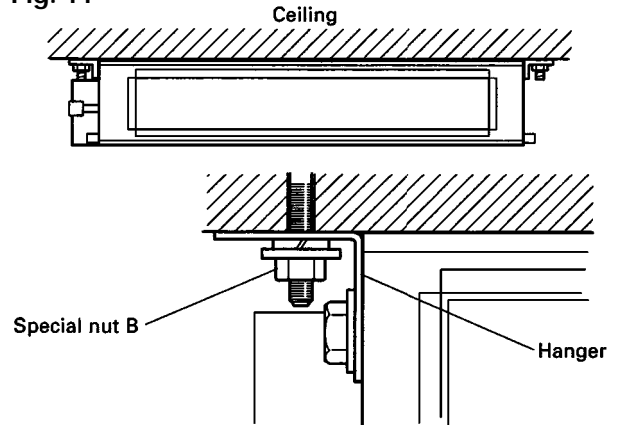

4. LEVELING

Base horizontal direction leveling on top of the unit.

Fig. 12

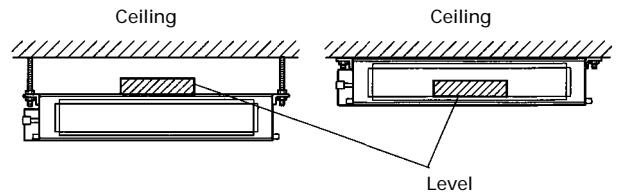

Base vertical direction leveling on the unit (right and left).

Fig. 13

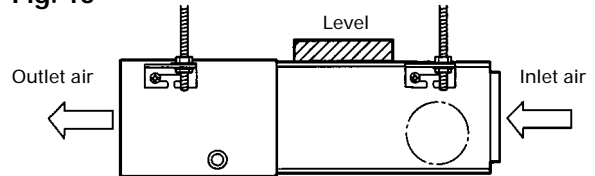

5. SERVICE HOLE DIMENSIONS

It shall be possible to install and remove the control box metal.

Fig. 14

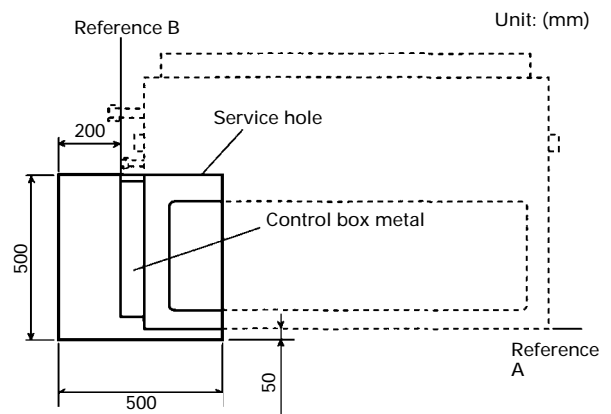

- Vertical dimension
500 mm from 50 mm below reference A
- Horizontal dimension
500 mm from 200 mm from the left from reference B

2. CONNECTING THE PIPING

⚠ CAUTION

- (1) Do not use mineral oil on flared part. Prevent mineral oil from getting into the system as this would reduce the lifetime of the units.
- (2) Never use piping which has been used for previous installations. Only use parts which are delivered with the unit.
- (3) While welding the pipes, be sure to blow dry nitrogen gas through them.

1. FLARE PROCESSING

- (1) Cut the connection pipe with pipe cutters so that the pipe is not deformed.
- (2) Holding the pipe downward so that cuttings cannot enter the pipe, remove the burrs.
- (3) Remove the flare nut from the indoor unit pipe and outdoor unit and assemble as shown in (Table 3) and insert the flare nut onto the pipe, and flare with a flaring tool.
- (4) Check if the flared part "L" (Fig. 15) is spread uniformly and that there are no cracks.

Table 3

Pipe	Flare nut
Small pipe (9.53 mm dia.)	Small (width across flats 22 mm)
Large pipe (15.88 mm dia.)	Large (width across flats 24 mm)
Large pipe (19.05 mm dia.)	Large (width across flats 36 mm)

Fig. 15

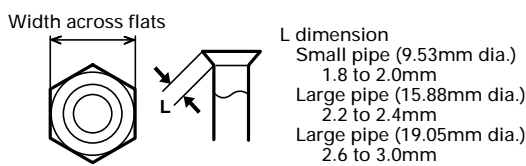

2. BENDING PIPES

The pipes are shaped by your hands. Be careful not to collapse them.

Fig. 16

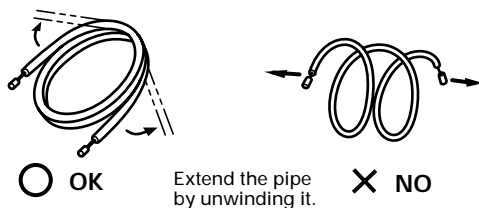

Do not bend the pipes in an angle more than 90°.

When pipes are repeatedly bent or stretched, the material will harden, making it difficult to bend or stretch them any more. Do not bend or stretch the pipes more than three times.

When bending the pipe, do not bend it as is. The pipe will be collapsed. In this case, cut the heat insulating pipe with a sharp cutter as shown in Fig. 17, and bend it after exposing the pipe. After bending the pipe as you want, be sure to put the heat insulating pipe back on the pipe, and secure it with tape.

Fig. 17

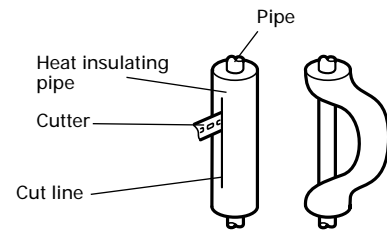

3. CONNECTION PIPES

Detach the caps and plugs from the pipes.

⚠ CAUTION

Be sure to apply the pipe against the port on the indoor unit correctly. If the centering is improper, the flare nut cannot be tightened smoothly. If the flare nut is forced to turn, the threads will be damaged.

Centering the pipe against port on the indoor unit, turn the flare nut with your hand.

⚠ CAUTION

Hold the torque wrench at its grip, keeping it in the right angle with the pipe as shown in Fig. 19, in order to tighten the flare nut correctly.

When the flare nut is tightened properly by your hand, use a torque wrench to finally tighten it.

Fig. 18

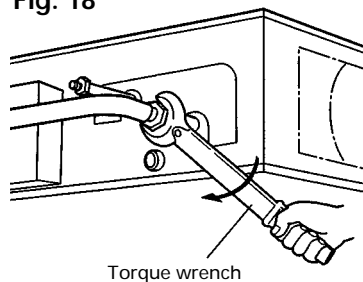

Fig. 19

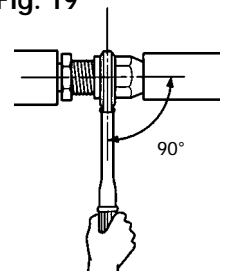

Table 4 : Flare nut tightening torque

Pipe	Tightening torque
Small pipe (9.53 mm dia.)	310 to 350 kgf · cm (30.4 to 34.3 N · m)
Large pipe (15.88 mm dia.)	750 to 800 kgf · cm (73.5 to 78.4 N · m)
Large pipe (19.05 mm dia.)	800 to 1,000 kgf · cm (78.4 to 98 N · m)

⚠ CAUTION

Be sure to connect the large pipe after connecting the small pipe completely.

4. CHECKING THE PIPE CONNECTIONS FOR GAS LEAKING

For both the indoor and outdoor unit sides, check the joints for gas leaking by the use of a gas leakage detector without fail when the pipes are connected.

5. HEAT INSULATION ON THE PIPE JOINTS

- Stick coupler heat insulation (large and small) to the place where connecting pipes.
- When using auxiliary piping with large pipe, stick coupler heat insulation (large) to the pipe at the two places shown below.

Fig. 20

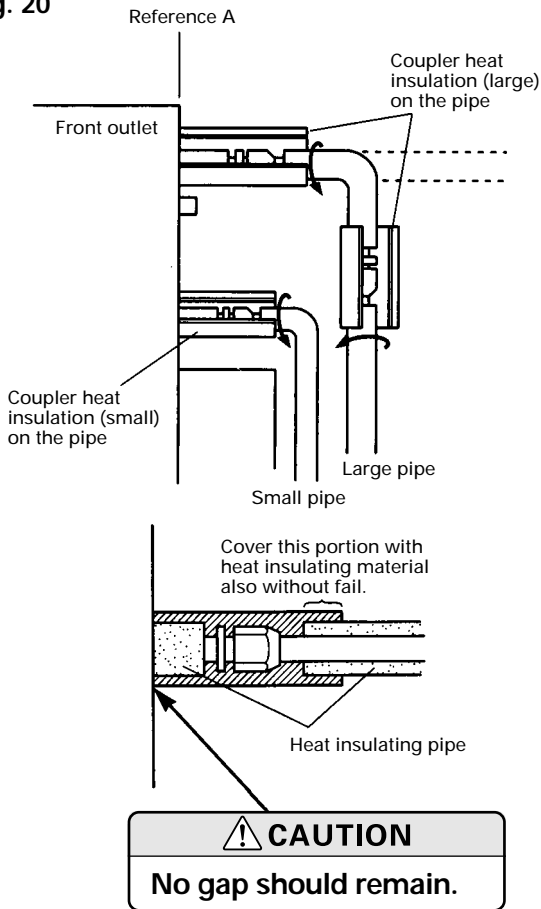

6. CONNECTING AN INDOOR CAPILLARY TUBE

These instructions refer to the 25,000•30,000 and 36,000 BTU/h versions.

Installation Procedure

- (1) Braze each part (connection pipe, indoor capillary tube, and branch liquid pipe) as shown in Fig. 21.
- (2) Wrap the two BR sheets around the indoor capillary tube as shown in Fig. 22.
- (3) Cover the indoor capillary tube and the branch liquid pipe with insulation (Fig. 23) and affix the insulation with tape.
- (4) Secure the insulation using the binders (Fig. 24).
 - If the joint pipe must be installed, refer to the installation manual for the outdoor unit for details.

Fig. 21

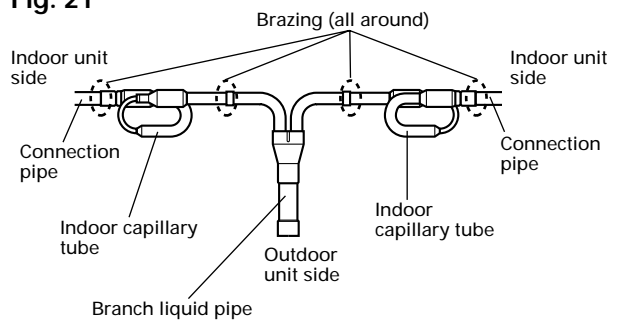

Fig. 22

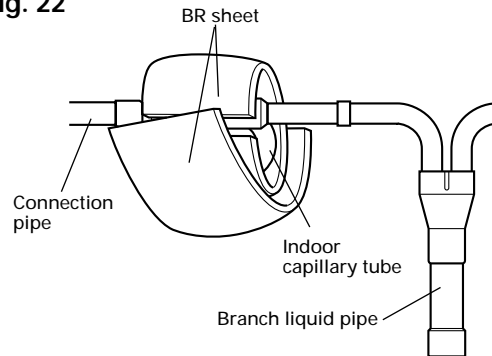

Fig. 23

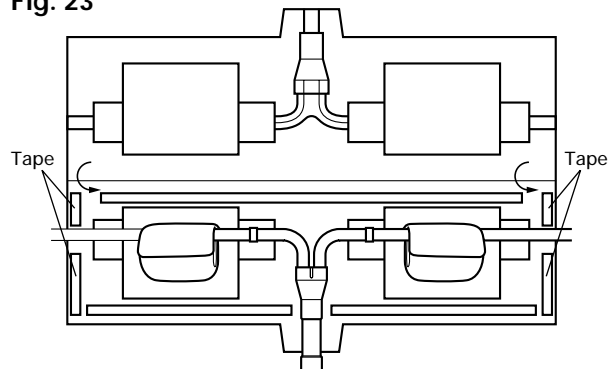
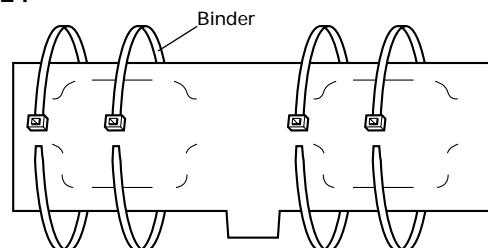

Fig. 24



3. INSTALLING DRAIN HOSE

NOTE : INSTALL THE DRAIN HOSE

- Install the drain hose with downward gradient (1/50 to 1/100) and so there are no rises or traps in the hose.
- Use general hard polyvinyl chloride pipe (VP25) [outside diameter 38 mm] and connect it with adhesive (polyvinyl chloride) so that there is no leakage.
- When the hose is long, install supporters.
- Do not perform air bleeding.
- Always heat insulate the indoor side of the drain hose.

Fig. 25

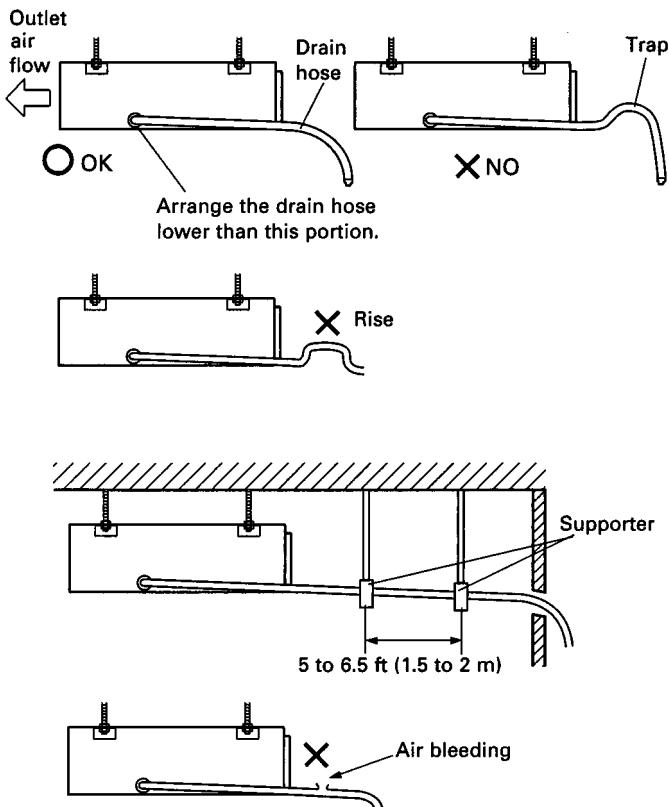

- The outside diameter of the drain port is 38 mm. Use a suitable drain hose.
- There is a drain port on both the left and right sides. Select the drain port to match the local conditions.

Fig. 26

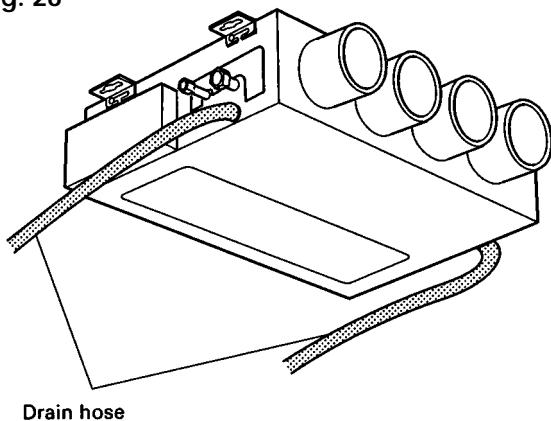

- When the unit is shipped from the factory, the drain port is on the left side (control box side).
- When using the drain port on the right side of the unit, reinstall the drain cap to the left side drain port.

Fig. 27

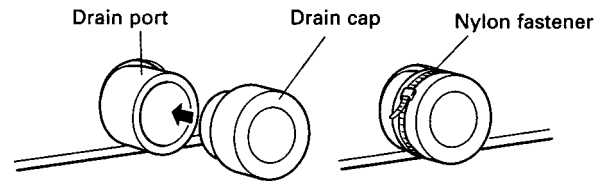

CAUTION

Always check that the drain cap is installed to the unused drain port and is fastened with the nylon fastener. If the drain cap is not installed, or is not sufficiently fastened by the nylon fastener, water may drip during the cooling operation.

- Cut the drain hose insulation at a position approximately 30 mm from the end with cutters, etc (Fig. 28-(1)).
- Stick the large drain hose insulation at the drain hose installation side (Fig. 28-(2)).
- Stick the small drain hose insulation at the drain cap side (Fig. 28-(3)).

Fig. 28-(1)

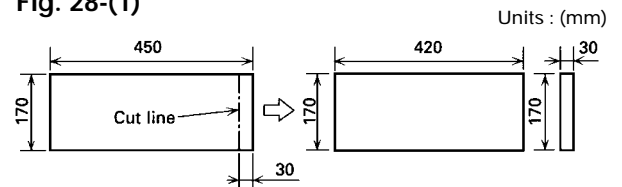

Fig. 28-(2)

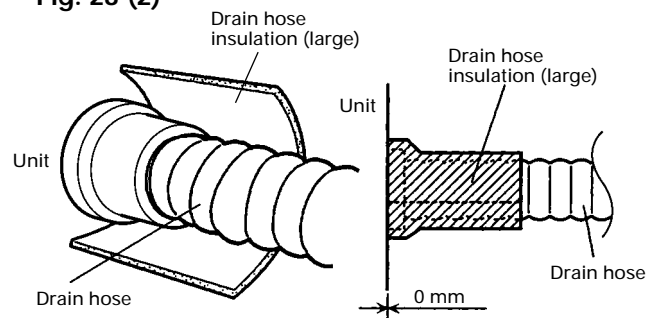
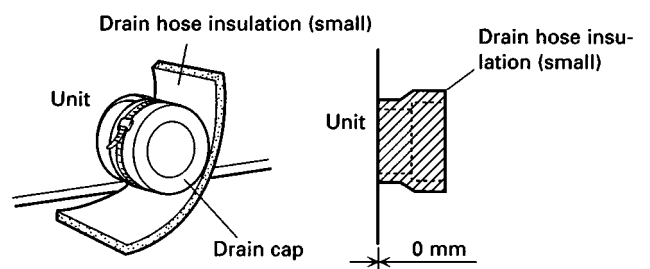

Fig. 28-(3)



4. ELECTRICAL WIRING

HOW TO CONNECT WIRING TO THE TERMINALS

1. IF ONE WIRE IS CONNECTED TO ONE TERMINAL BLOCK

A. For solid core wiring (or F-cable)

- (1) Cut the wire and with a wire cutter or wirecutting pliers, then strip the insulation to about 15/16" (25 mm) to expose the solid wire.
- (2) Using a screwdriver, remove the terminal screw(s) on the terminal board.
- (3) Using pliers, bend the solid wire to form a loop suitable for the terminal screw.
- (4) Shape the loop wire properly, place it on the terminal board and tighten securely with the terminal screw using a screwdriver.

B. For strand wiring

- (1) Cut the wire and with a wire cutter or wirecutting pliers, then strip the insulation to about 3/8" (10 mm) to expose the strand wiring.
- (2) Using a screwdriver, remove the terminal screw(s) on the terminal board.
- (3) Using a round terminal fastener or pliers, securely clamp a round terminal to each stripped wire end.
- (4) Position the round terminal wire, and replace and tighten the terminal screw using a screwdriver.

Fig. 29

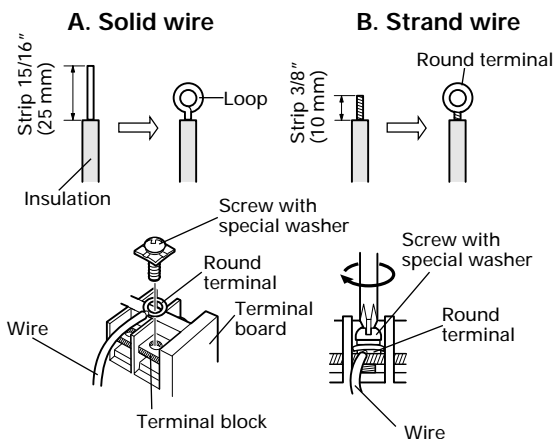

2. IF TWO WIRES ARE CONNECTED TO ONE TERMINAL BLOCK

A. As a rule, round terminal should be used to connect to the terminal block.

- (1) Cut the wire and with a wire cutter or wirecutting pliers, then strip the insulation to about 3/8" (10 mm) to expose the strand wiring.
- (2) Using a screwdriver, remove the terminal screw(s) on the terminal board.
- (3) Using a round terminal fastener or pliers, securely clamp a round terminal to each stripped wire end.
- (4) Position the round terminal wire, and replace and tighten the terminal screw using a screwdriver.

Fig. 30

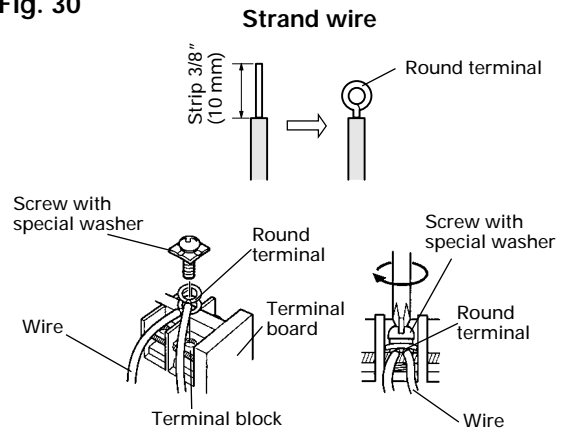

B. If round terminal cannot be used, the following items should be followed.

For solid core wiring (or F-cable)

- (1) Cut the wire and with a wire cutter or wirecutting pliers, then strip the insulation to about 1/2" (12.7 mm) to expose the solid wire.
- (2) Using a screwdriver, remove the terminal screw(s) on the terminal board.
- (3) Wires with the same diameter should be connected on both sides as shown in Fig. 31.

Since connecting wires with different diameters causes the wires to heat up due to loose connections, this method should not be used.

Fig. 31

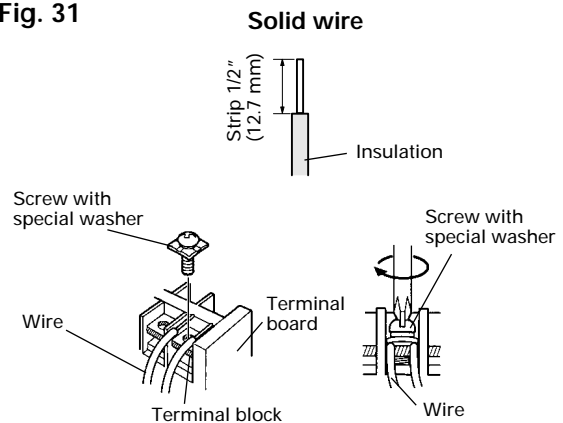

HOW TO FIX THE CONNECTION CORD

After passing the connection cord through the insulation tube, fasten it with the cord clamp.

Fig. 32

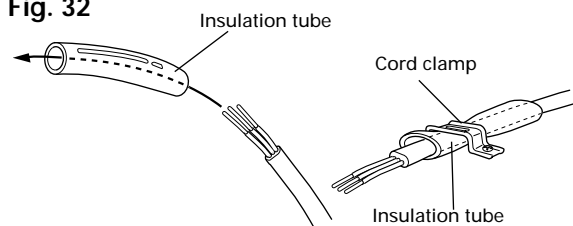

Use VW-1, 0.5 to 1.0 mm thick, PVC tube as the insulation tube.

⚠ WARNING

- (1) Before starting work, check that power is not being supplied to the indoor unit.
- (2) Always fasten the outside covering of the connection cord with the cord clamp. (If the insulation is chafed, electric leakage may occur.)

(1) Remove the control box metal-B from the control box metal assy.

Fig. 33

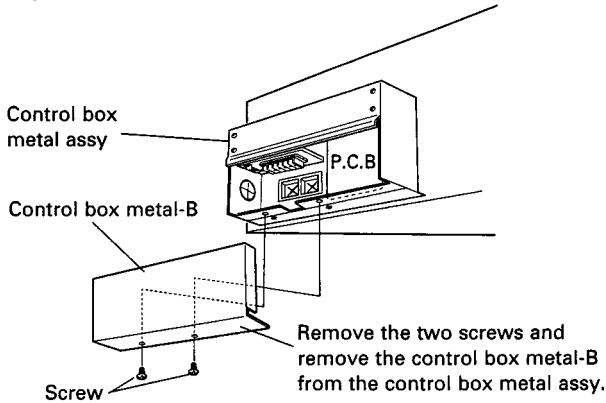

CONNECTION CORD

A. Simultaneous operation for buildings

Fig. 34

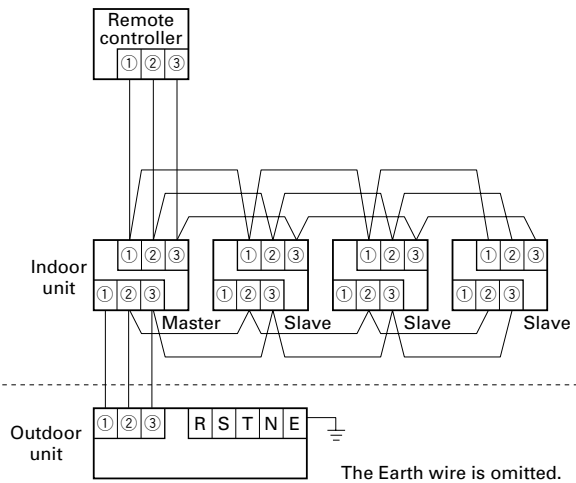

⚠ CAUTION

- (1) Connect a maximum of 2 wires on a single terminal block. (If 3 or more wires are connected, they could become loose and cause heating.)

Fig. 35

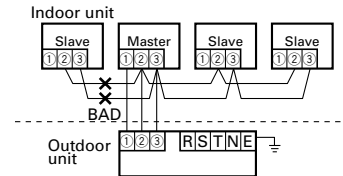

- (2) Crossovers as in (1) should not be connected when connecting wires between the master unit and slave units, and from slave unit to slave unit. (The system will not operate correctly.)

Fig. 36

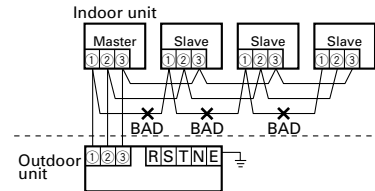

B. Individually operation for buildings

Fig. 37

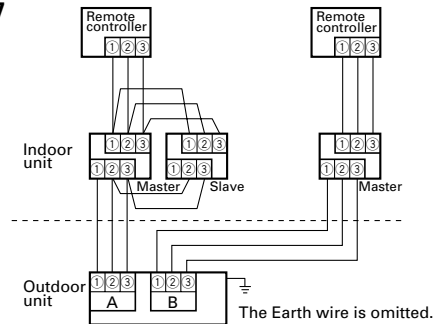

(2) Connection cord and remote controller cord connections

- Clamp the connection cord with the cable clamp and the remote controller cord with the nylon clamp.
- Connect the connection cord to the terminals with the white characters on the terminal nameplate.
- Connect the remote controller cord to the terminals with the black characters on the terminal nameplate.

Fig. 38

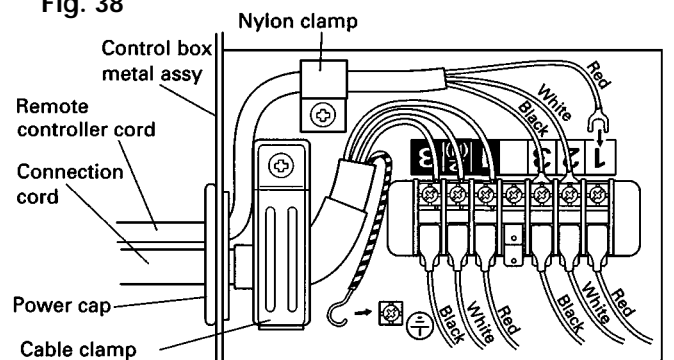

CAUTION

- (1) Tighten the indoor unit connection cord (to the outdoor unit) and power supply indoor and outdoor unit terminal board connections firmly with the terminal board screws. Faulty connection may cause a fire.
- (2) If the indoor unit connection cord (to the outdoor unit) and power supply are wired incorrectly, the air conditioner may be damaged.
- (3) Wire the indoor unit connection cord (to the outdoor unit) by matching the numbers of the outdoor and indoor units terminal board numbers as shown in (Fig. 38).
- (4) Ground both the indoor and outdoor units by attaching a ground wire.
- (5) Unit shall be grounded in compliance with the applicable local and national codes.

(3) Control box metal-B installation
Fasten control box metal-B with the two screws.
For the connection cord outlet port see Fig. 39.

Fig. 39

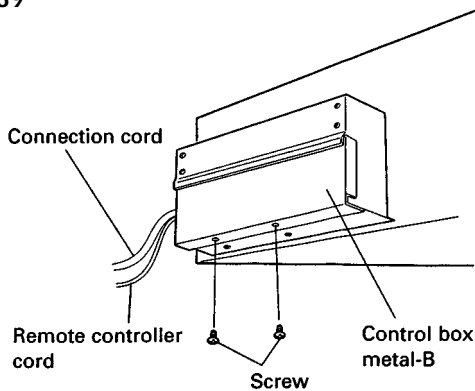

5. MASTER/SLAVE SELECT SWITCH

Fig. 40

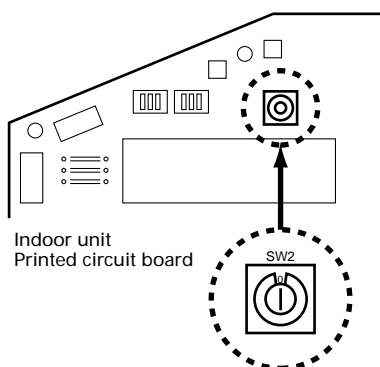

- For the master unit, set SW2 on "0". For a slave unit, set SW2 on "1-3".

Fig. 41 [Example]

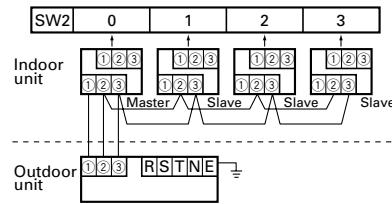

- A master unit is an indoor unit with the power line connected directly from the outdoor unit.

6. REMOTE CONTROLLER INSTALLATION

- Insert the end of a flat blade screwdriver at the arrow parts of the groove at the side of the remote controller case and remove the remote controller case top by turning the screwdriver.
- Disconnect the remote controller cord from the remote controller terminal board.

Fig. 42

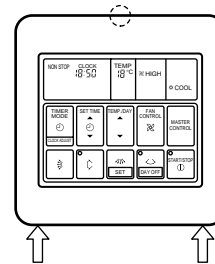

- (1) When remote controller exposed
 - 1) Make a notch in the thin part (part of Fig. 42) at the remote controller case top and bottom with nippers, file, etc.
 - 2) Connect the remote controller cord to the remote controller terminal board specified in (Fig. 43).
 - 3) Clamp the remote controller cord sheath with the binder (small) as shown in Fig. 43.
 - 4) Cut off the excess binder.

Fig. 43

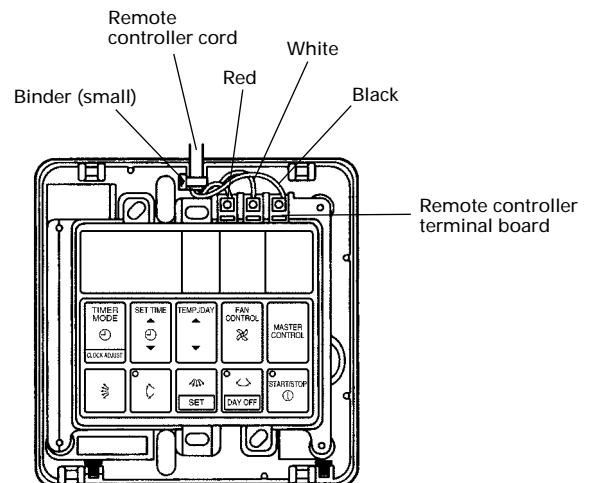

- (2) When remote controller cord embedded
 - 1) Embed the remote controller cord and box.
 - 2) Pass the remote controller cord through the hole at the remote controller case bottom and install the cord to the box (Fig. 44).
 - 3) Connect the remote controller cord to the remote controller terminal board specified in (Fig. 43).

Fig. 44 [Example]

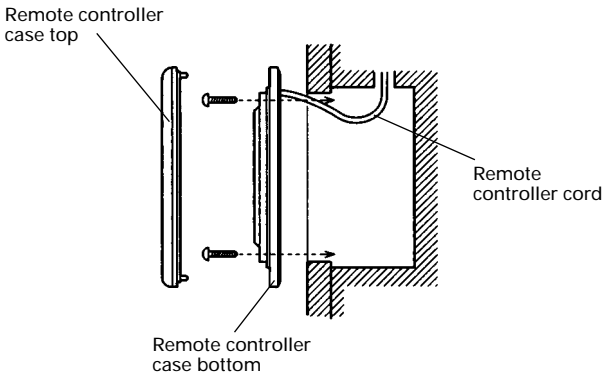

- After wiring work is complete, return the remote controller case top to its original state.

⚠ CAUTION
<p>(1) Do not bundle the remote controller cord, or wire the remote controller cord in parallel, with the indoor unit connection wire (to the outdoor unit) and the power supply cord. It may cause erroneous operation.</p>
<p>(2) When installing the remote controller and cord near a source of electromagnetic waves, separate the remote controller from the source of the electromagnetic waves and use shielded cord.</p>
<p>(3) Do not touch the remote controller PC board and PC board parts directly with your hands.</p>

7. TEST RUNNING

REMOTE CONTROLLER

- Supply power to the crankcase heater 12 hours before the start of operation in the winter.
- For test running, when the remote controller FAN CONTROL button and MASTER CONTROL button are pressed simultaneously for more than three seconds when the air conditioner is not running, the air conditioner starts and TEST is displayed on the remote controller display. However, the SET TEMP./DAY setting button does not function, but all other buttons, displays, and protection functions operate (Fig. 45).

Fig. 45

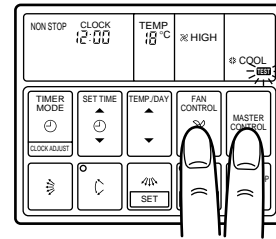

- When EE : EE blinks at the current time display, there is an error inside the air conditioner. If the SET TIME button (▼) and SET TEMP./DAY button (▼) are pressed simultaneously for more than three seconds, the self diagnosis check will start and the error contents will be displayed at the current time display. (Fig. 46) When the operation lamp lights, press the START/STOP button and after operation lamp goes off, perform the same operation. (Fig. 46) Process the error contents by referring to (Table 5).

Fig. 46

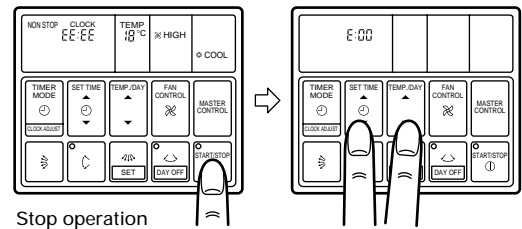

Table 5

Error cord	Error contents
E:00	Communication error (indoor unit ↔ remote controller)
E:01	Communication error (indoor unit ↔ outdoor unit)
E:02	Room temperature sensor open
E:03	Room temperature sensor shorted
E:04	Indoor heat exchanger temperature sensor open
E:05	Indoor heat exchanger temperature sensor shorted
E:06	Outdoor heat exchanger temperature sensor open
E:07	Outdoor heat exchanger temperature sensor shorted
E:08	Power source connection error
E:09	Float switch operated
E:0A	Outdoor temperature sensor open
E:0B	Outdoor temperature sensor shorted
E:0C	Discharge pipe temperature sensor open
E:0D	Discharge pipe temperature sensor shorted
E:0E	Outdoor low pressure abnormal
E:0F	Discharge pipe temperature abnormal
E:11	Model abnormal
E:12	Indoor fan abnormal
E:13	Outdoor signal abnormal
E:14	Outdoor EEPROM abnormal

- To stop test running, press the START/STOP button.
- For the operation method, refer to the operating manual and perform operation check.
- Check that there are no abnormal sounds or vibration sounds during test running.

8. STATIC PRESSURE CHARACTERISTIC

Fig. 47 FAN PERFORMANCE AND AIR FLOW EXTERNAL STATIC PRESSURE

25,000 BTU/h class

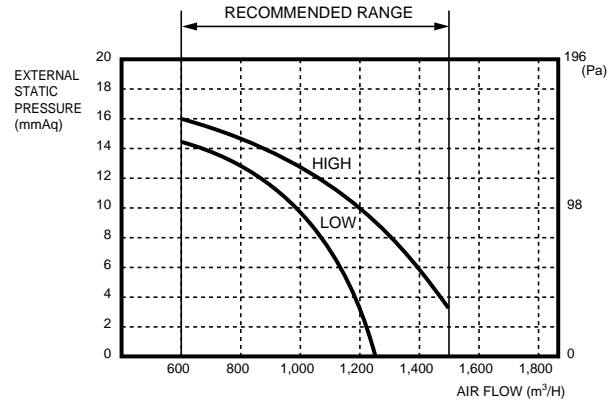

30,000 BTU/h class

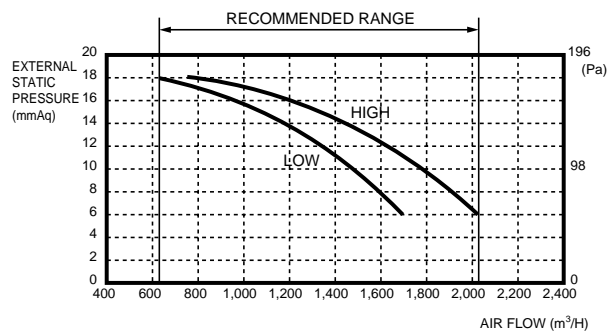

36,000 BTU/h class

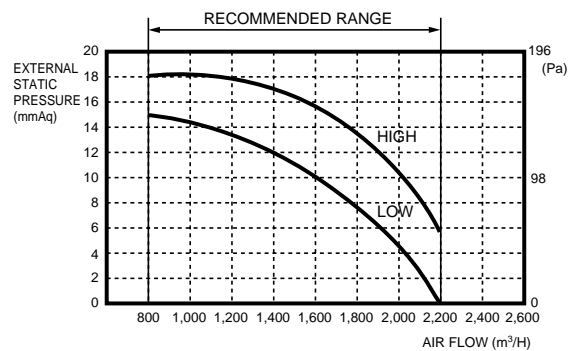

45,000 BTU/h class

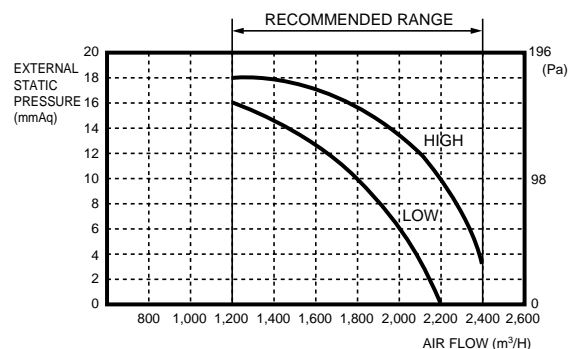

9. OUTLET DUCT CONNECTION

1. DUCT INSTALLATION PATTERN (■ CUT PART)

Fig. 48

(1) Square duct



(2) Round duct outlet x 4 (This is the factory setting.)



2. WHEN USING AS A SQUARE DUCT

(1) Cut the slit seam ○ with a cutter.

Fig. 49

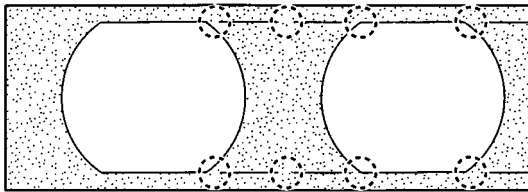

(2) Turn up the insulation around the points to be cut according to the outlet port shape working points so that the insulation does not stick out at the  part.

Fig. 50



(3) Cut with nippers and remove the sheet metal.
 (4) Since there is a slit in the insulation, use radio pliers, tweezers, etc. to stretch tight the screw hole part used when installing the round flange and square flange when connecting the duct.

Fig. 51

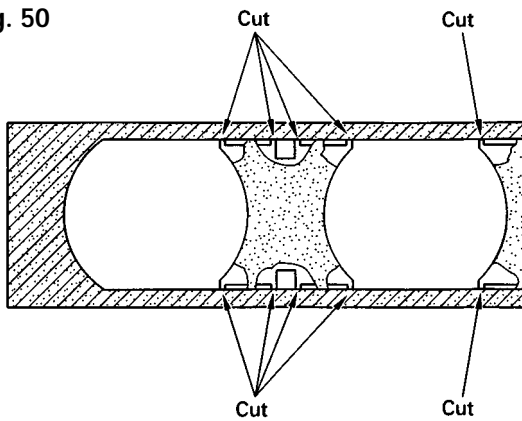
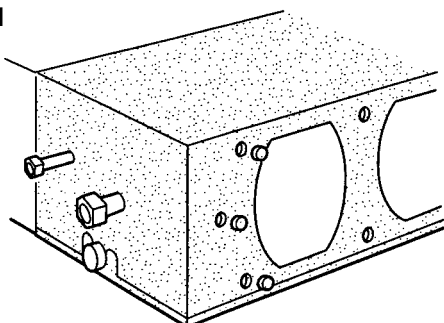

3. SPECIAL ITEMS

When connecting the square duct and round duct, use the optional square flange or round flange and flexible duct.

Fig. 52

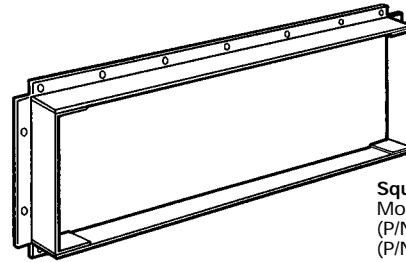

Square flange
 Model name : UTD-SF045
 (P/N 9054229009)
 (P/N 9098180007)

• Square flange dimensions

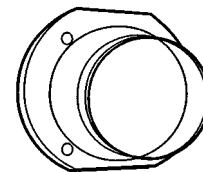
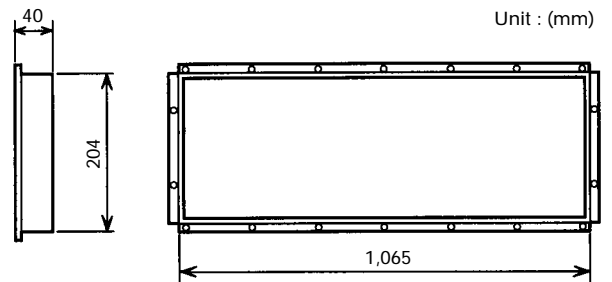

Round flange
 Model name : UTD-RF204
 (P/M 9093160004)

• Round flange dimensions

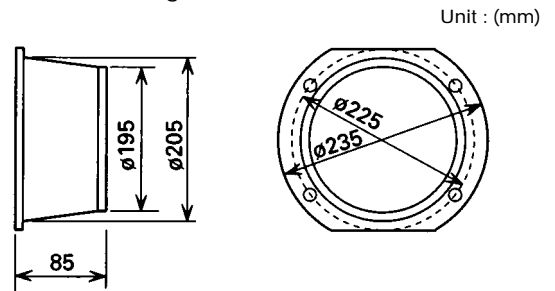

Flexible duct
 Model name : UTD-RD202
 (P/N 9074165004)

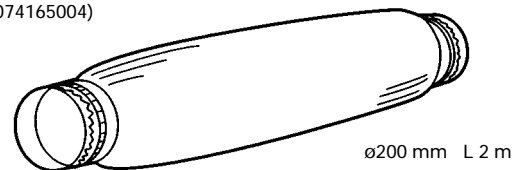

10. INTAKE PORT REAR COVER DIMENSIONS

Fig. 53

Unit:(mm)

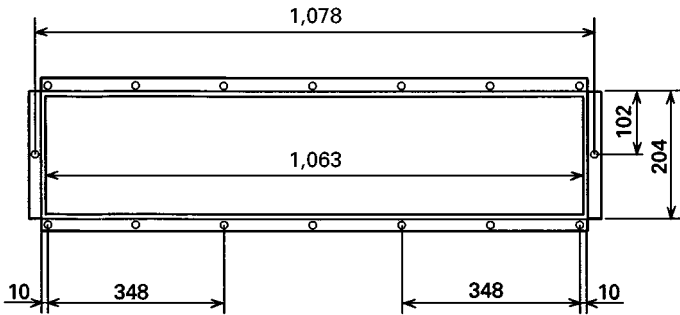

11. INTAKE PORT

- (1) The square flange (rear side) and panel (intake panel) are installed at the factory at the places shown in Fig. 54.
- (2) When taking in air from the bottom side, reinstall the square flange (rear side) and panel (intake panel).

⚠ CAUTION

When air is taken in from the bottom side, the operating sound of the product will easily enter the room.

Install the product and intake grilles where the affect of the operating sound is small.

Fig. 54

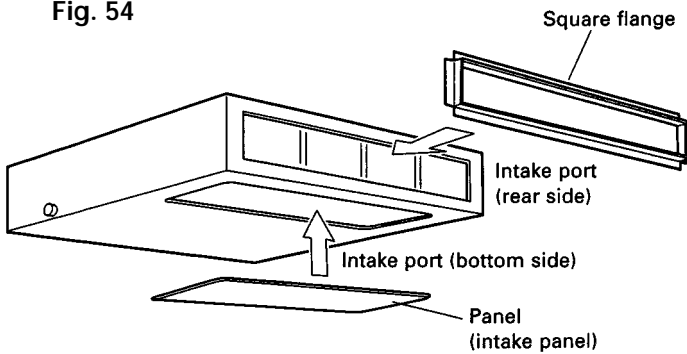

12. FRESH AIR INTAKE (Processing before use)

- (1) When taking in fresh air, cut a slit shaped cabinet in the left side of the outer case as shown in Fig. 55 with nippers.

Fig. 55

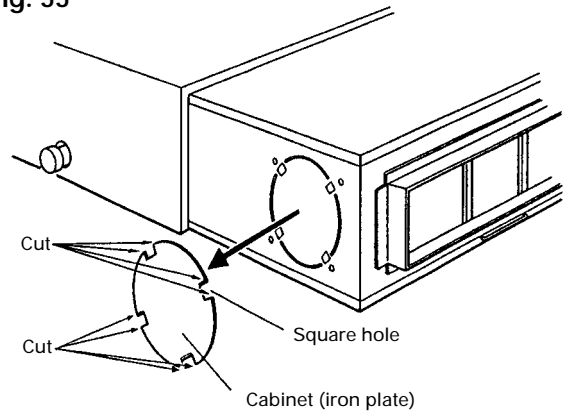

⚠ CAUTION

- (1) When removing the cabinet (iron plate), be careful not to damage the indoor unit internal parts and surrounding area (outer case).
- (2) When processing the cabinet (iron plate), be careful not to injure yourself with burrs, etc.

- (2) Install the round flange (option parts) to the fresh air intake.

Fig. 56

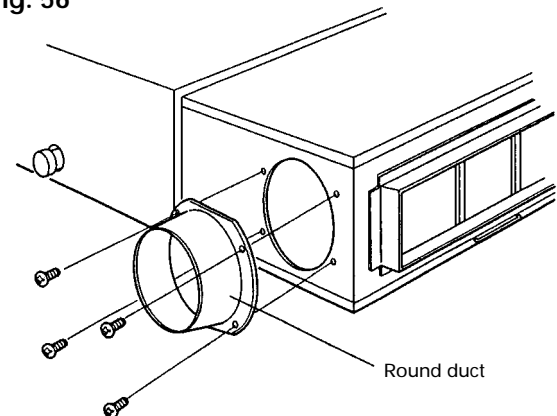

- (3) Connect the duct to the round flange.
- (4) Seal with a band and vinyl tape, etc. so that air does not leak from the connection.

Fig. 57

