



5

### VACUUM PROCESS

#### 1. VACUUM

- Remove the cap, and connect the gauge manifold and the vacuum pump to the charging valve hoses.
- Vacuum the indoor unit and the connecting pipes until the pressure in them lowers to below 1.5 mmHg.
- Disconnect the service hoses and fit the cap to the charging valve (Tightening torque : 70 to 90 kgf-cm).
- Remove the blank caps, and fully open the spindles of the 2-way and 3-way valves with a hexagon wrench (Torque : 2-way valve: 70 to 90 kgf-cm, 3-way valve: 100 to 120 kgf-cm).
- Tighten the blank caps of the 2-way valve and 3-way valve to the specified torque (200 to 250 kgf-cm).

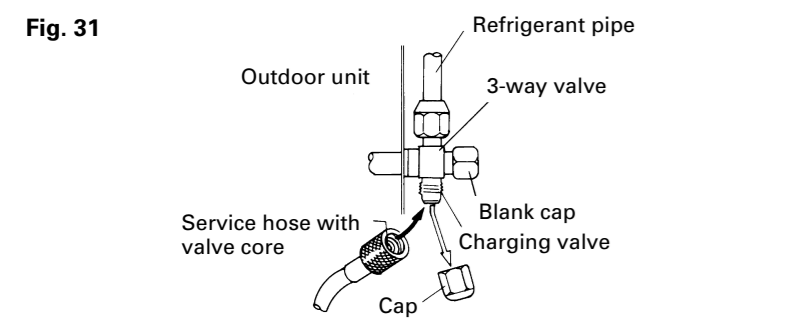

Fig. 31

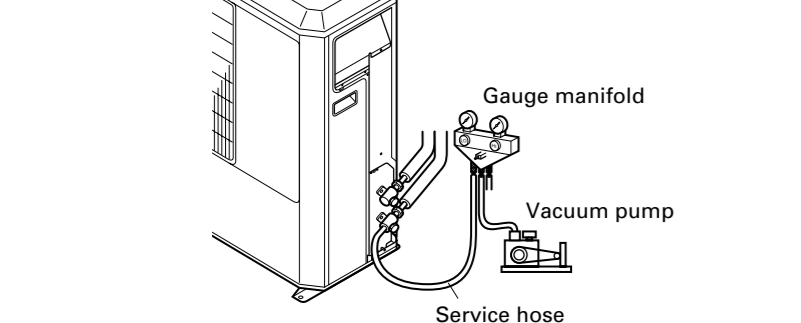

Fig. 32

#### 2. ADDITIONAL CHARGE

Refrigerant suitable for a piping length of 7.5 m is charged in the outdoor unit at the factory. When the piping is longer than 7.5 m, additional charging is necessary. For the additional amount, see the table below.

Pipe length	Table 5					
	25 ft (7.5 m)	33 ft (10 m)	49 ft (15 m)	66 ft (20 m)	82 ft (25 m)	99 ft (30 m)
Additional refrigerant	Heat & Cool (Reverse cycle)	None	4.4 oz (125 g)	13.2oz (375 g)	22.0 oz (625 g)	30.9 oz (875 g)
	Cooling model	None	1.8 oz (50 g)	5.3 oz (150 g)	8.8 oz (250 g)	12.3 oz (350 g)

Between 7.5 m and 30 m, when using a connection pipe other than that in the table, charge additional refrigerant with 1.8 oz (50 g)/3.3 ft (1 m) (Reverse cycle model), 0.7 oz (20 g)/3.3 ft (1 m) (Cooling model) as the criteria.

#### CAUTION

- When charging the refrigerant, always use a measuring cylinder.
- Add refrigerant from the charging valve after the completion of the work.

6

### INSTALLING THE COUPLER HEAT INSULATION

After checking for gas leaks, insulate by wrapping insulation around the two parts (large and small) of the indoor unit coupling, using the coupler heat insulation. After installing the coupler heat insulation, wrap both ends with vinyl tape so that there is no gap.

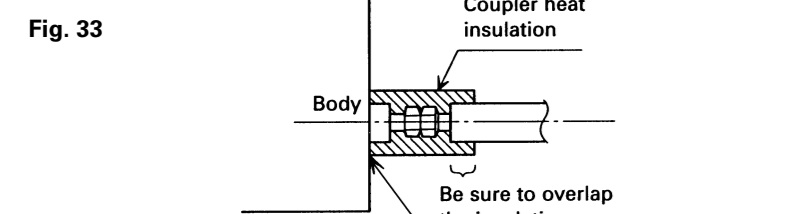
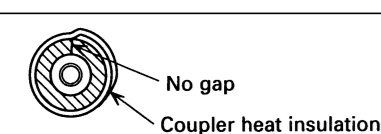

Fig. 33

#### CAUTION

Must fit tightly against body without any gap.



7

### ELECTRICAL WIRING

#### HOW TO CONNECT WIRING TO THE TERMINALS

##### A. For solid core wiring (or F-cable)

- Cut the wire end with a wire cutter or wire-cutting pliers, then strip the insulation to about 15/16" (25 mm) to expose the solid wire.
- Using a screwdriver, remove the terminal screw(s) on the terminal board.
- Using pliers, bend the solid wire to form a loop suitable for the terminal screw.
- Shape the loop wire properly, place it on the terminal board and tighten securely with the terminal screw using a screwdriver.

#### B. For strand wiring

- Cut the wire end with a wire cutter or wire-cutting pliers, then strip the insulation to about 3/8" (10 mm) to expose the strand wiring.
- Using a screwdriver, remove the terminal screw(s) on the terminal board.
- Using a round terminal fastener or pliers, securely clamp a round terminal to each stripped wire end.
- Position the round terminal wire, and replace and tighten the terminal screw using a screwdriver.

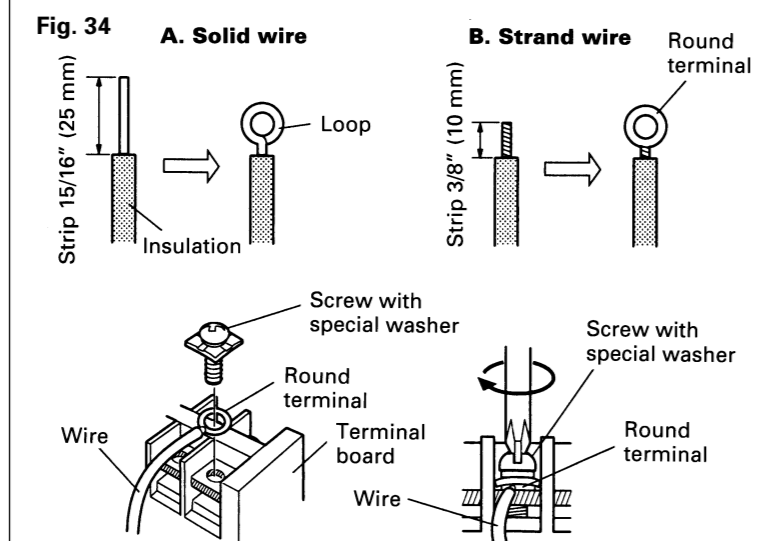

#### HOW TO FIXED CONNECTION CORD AND POWER SUPPLY CORD AT THE CORD CLAMP

After passing the connection cord and power supply cord through the insulation tube, fasten it with the cord clamp.

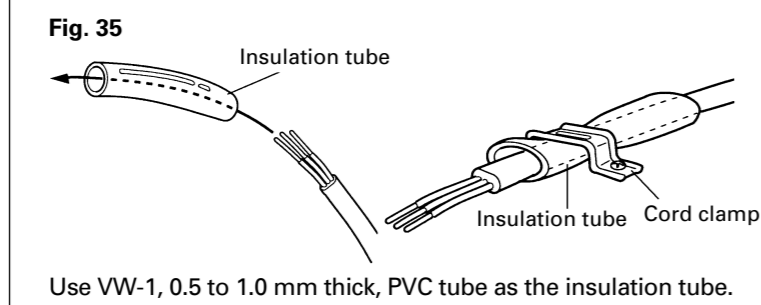

#### 1. INDOOR UNIT SIDE

##### WARNING

- Before starting work, check that power is not being supplied to the indoor unit and outdoor unit.
- Match the terminal board numbers and connection cord colors with those of the outdoor unit. Erroneous wiring may cause burning of the electric parts.
- Connect the connection cord firmly to the terminal board. Imperfect installation may cause a fire.
- Always fasten the outside covering of the connection cord with the cord clamp. If the insulator is chafed, electric leakage may occur.
- Always connect the ground wire.

- Remove the control box cover and cover (wire) B and install the connection cord.

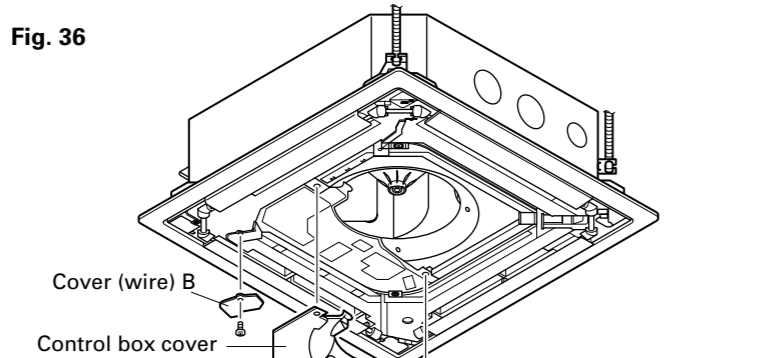

- After wiring is complete, clamp the remote controller cord and connection cord with the cord clamp.
- Install the control box cover and cover (wire) B.

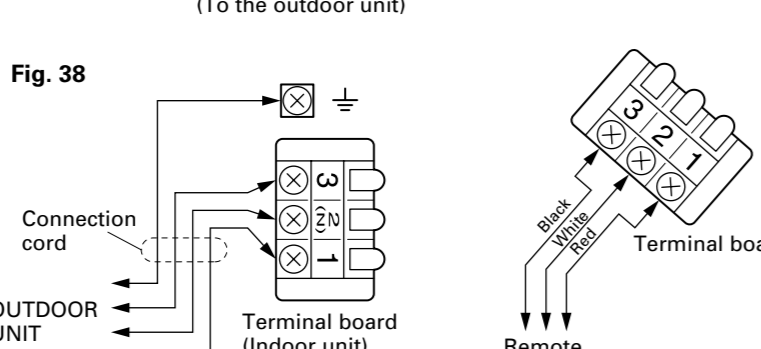
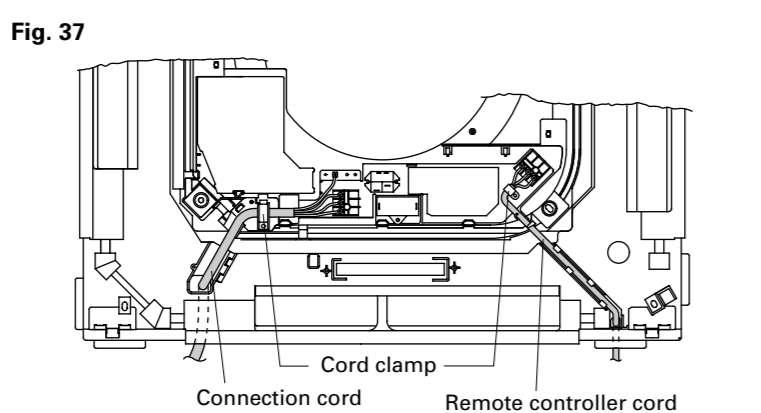

#### Ceiling height setting

Set the DIP switch for the ceiling height according to the table below.

Ceiling height (m)		DIP-SW4		
		1	2	3
2.5 - 3.0	Normal	—	OFF	OFF
3.0 - 3.5	High ceiling 1	—	ON	OFF
More than 3.5	High ceiling 2	—	OFF	ON
Less than 2.5	Low ceiling	—	ON	ON

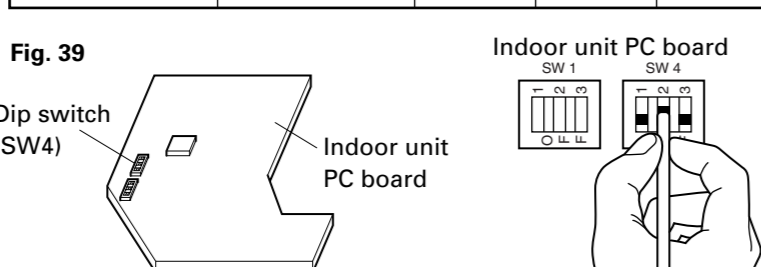

Fig. 39

#### CAUTION

- If the setting for a low ceiling is selected, the capacity of the air conditioner decreases slightly.
- Do not set any switches other than those specified in this sheet or the remote controller installation instruction sheet. The air conditioner may not operate correctly if any switches other than those specified are changed.

#### 2. OUTDOOR UNIT SIDE

##### WARNING

- Before starting work, check that power is not being supplied to the indoor unit and outdoor unit.
- Match the terminal board numbers and connection cord colors with those of the indoor unit side. Erroneous wiring may cause burning of the electric parts.
- Connect the connection cords and the power supply cord firmly to the terminal board. Imperfect installation may cause a fire.
- Always fasten the outside covering of the connection cord and the power supply cord with cord clamps. (If the insulator is chafed, electric leakage may occur.)
- Always connect the ground wire.

- Remove outdoor unit valve cover and connect the power cord and the outdoor unit connection cord wired at the indoor unit.
- Fasten the power cord and connection cord with cable clip and binders as shown in (Fig. 41)

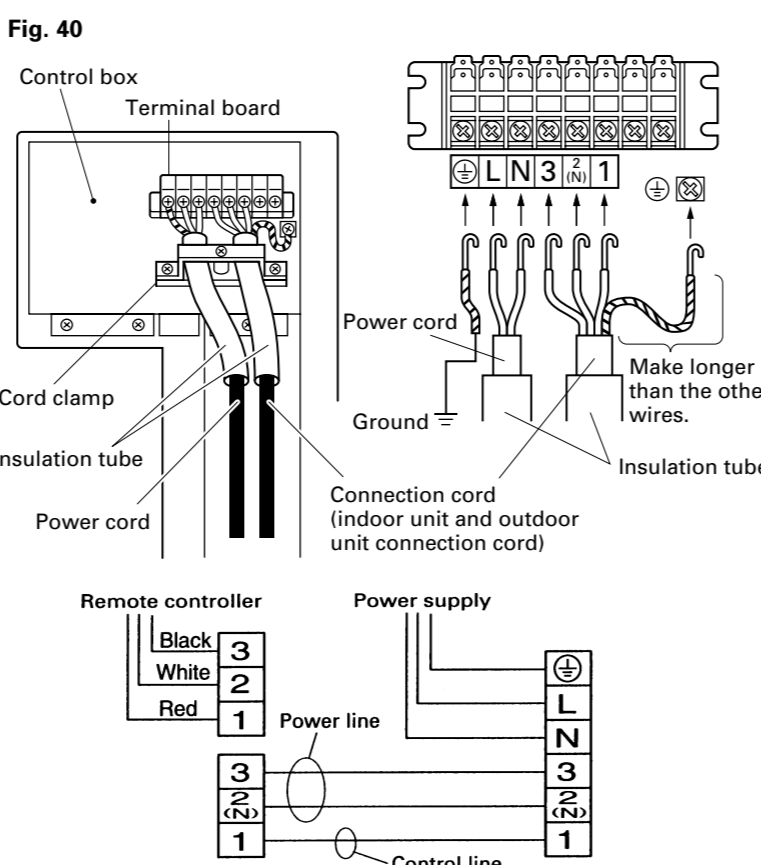

Fig. 40

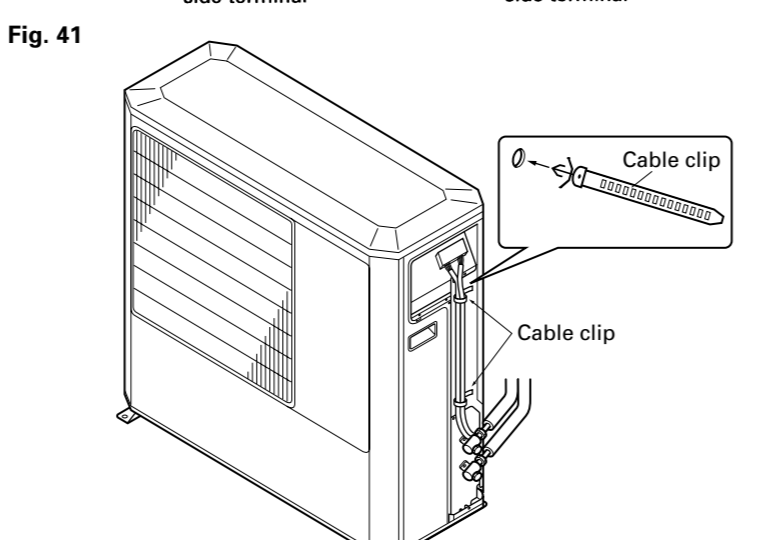

Fig. 41

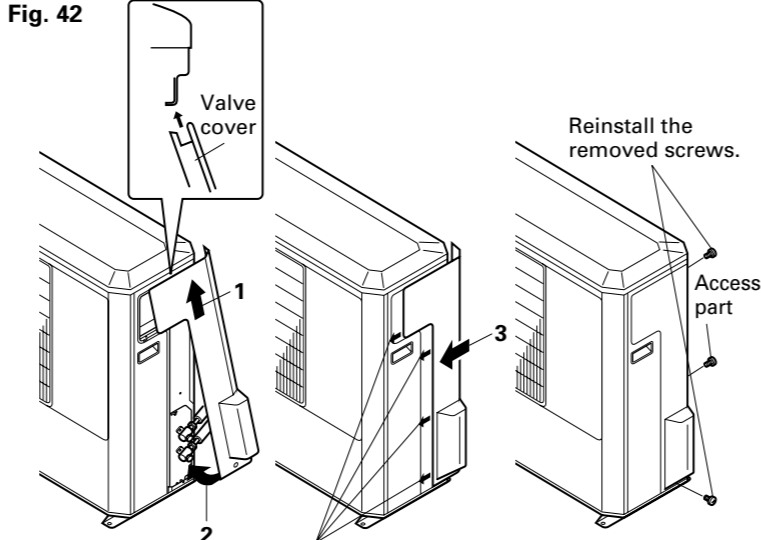

Fig. 42

#### 8 GRILLE INSTALLATION

**BLOWER COVER INSULATION**  
Install the blower cover insulation only when the outlet direction is not specified. Two blower cover insulations are packed with the indoor unit. Install the blower cover insulation at the diffuser position shown in Fig. 43. At this time, use the piping position as the criteria.

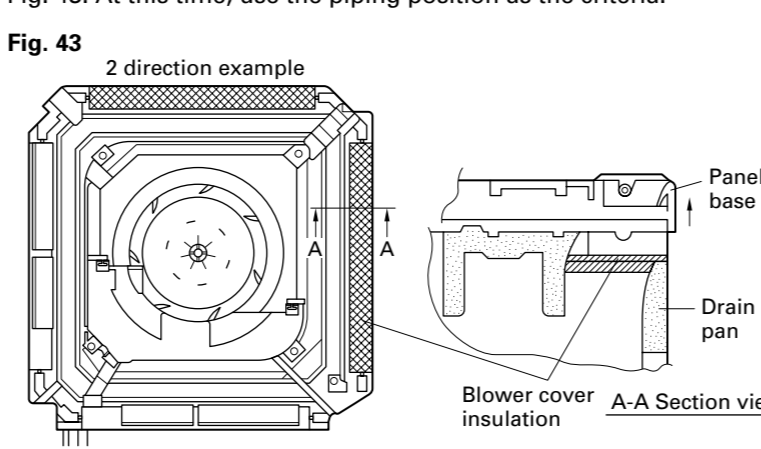

Fig. 43

#### INSTALLING THE INTAKE GRILLE

- Mount the grille hinge wire to the hook shaft as shown in Fig. 44.

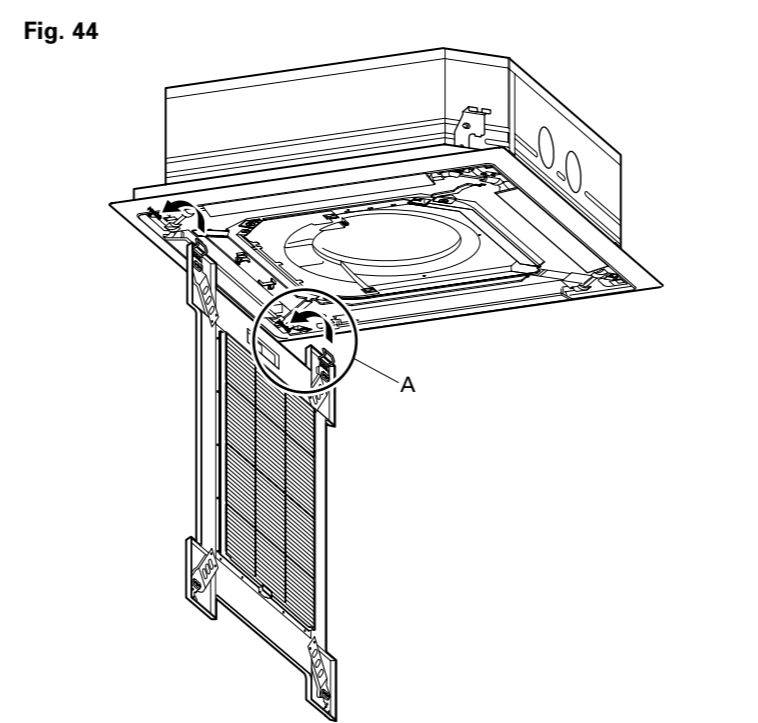

Fig. 44

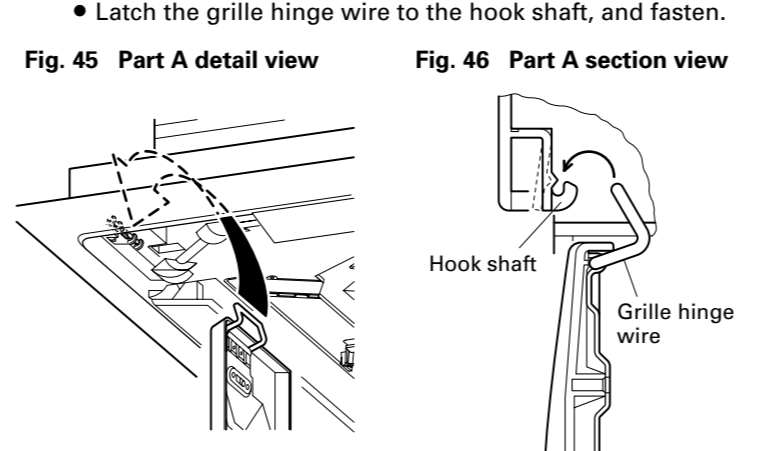

Fig. 45 Part A detail view

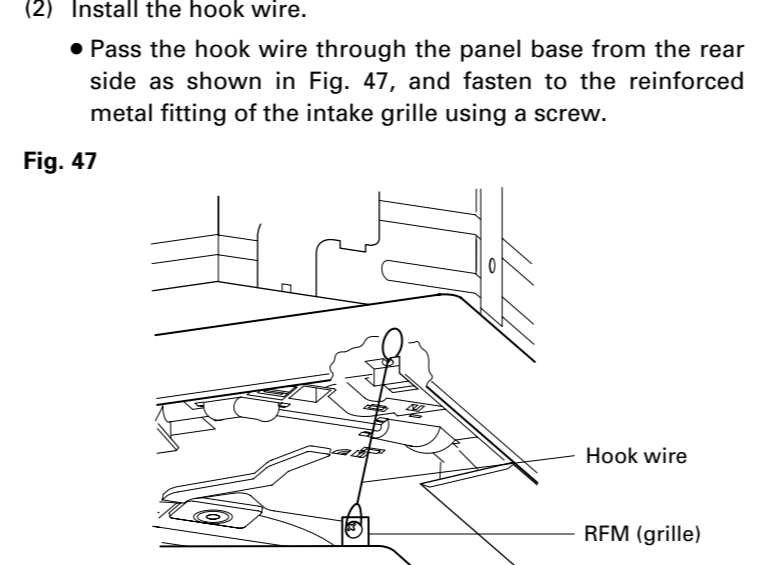

Fig. 46 Part A section view

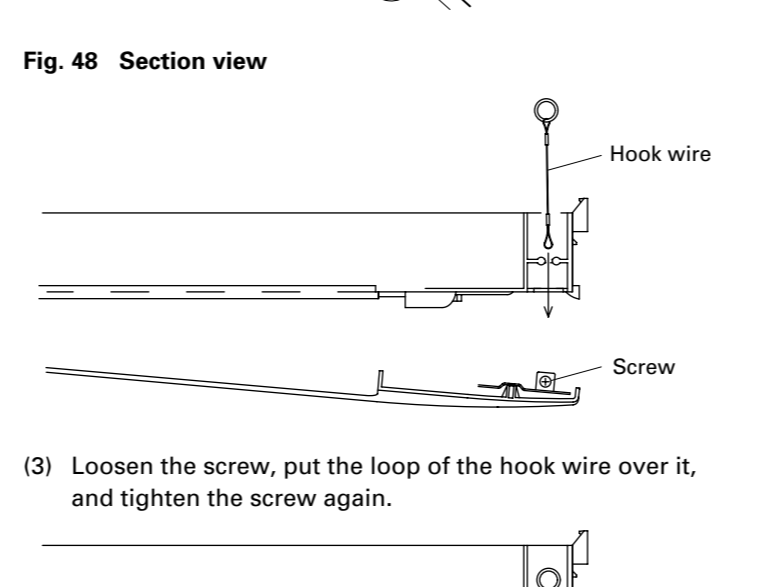

Fig. 47

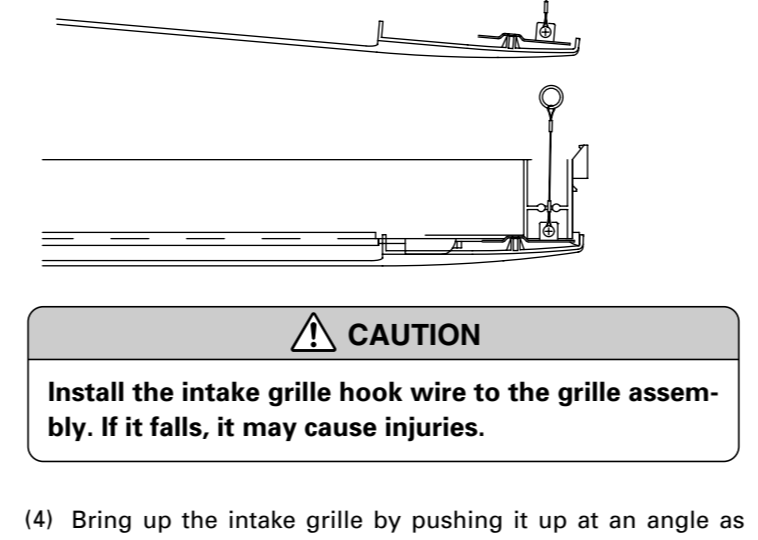

Fig. 48 Section view

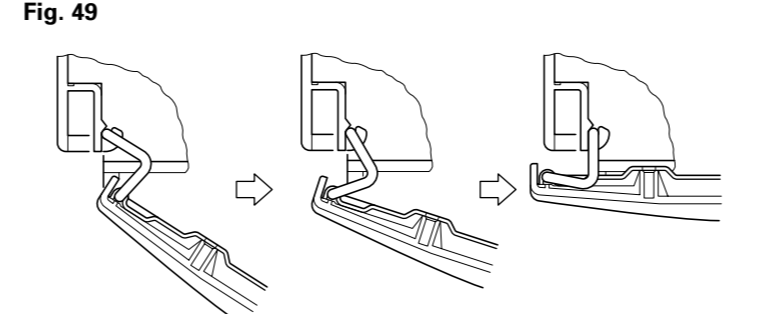

Fig. 49

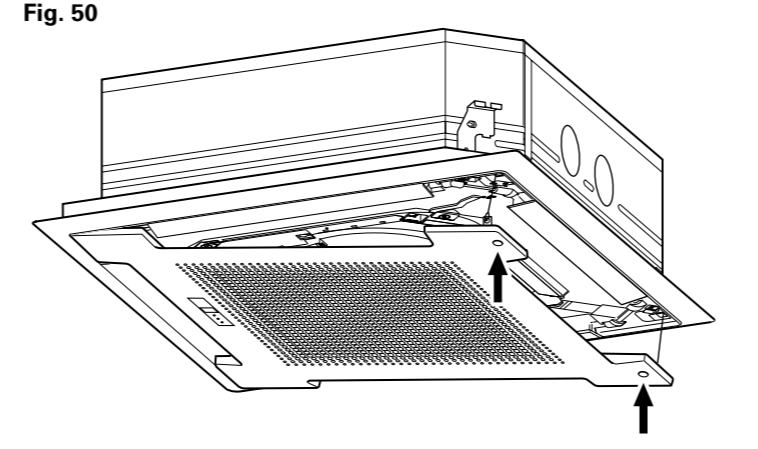

Fig. 50

#### CAUTION

Install the intake grille hook wire to the grille assembly. If it falls, it may cause injuries.

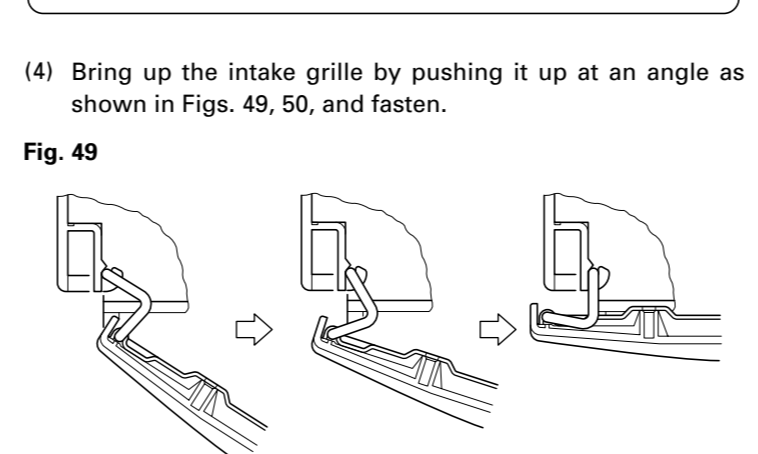

Fig. 51

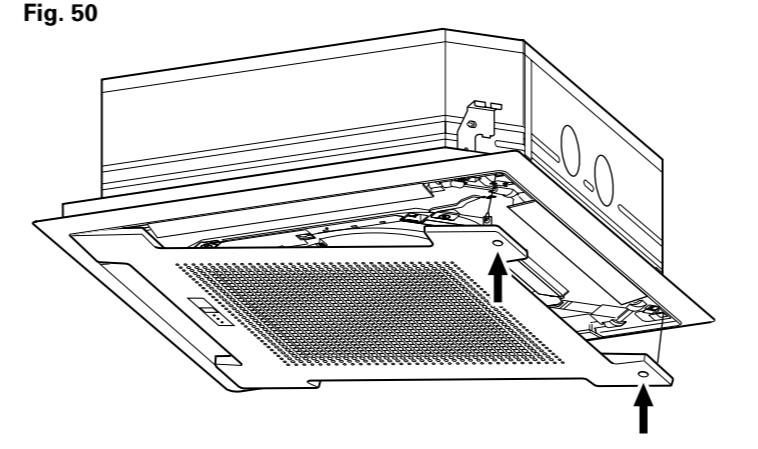

Fig. 52

Fig. 53

Fig. 54

Fig. 55

Fig. 56

Fig. 57

Fig. 58

Fig. 59

Fig. 60

Fig. 61

Fig. 62

Fig. 63

Fig. 64

Fig. 65

Fig. 66

Fig. 67

Fig. 68

Fig. 69

Fig. 70

Fig. 71

Fig. 72

Fig. 73

Fig. 74

Fig. 75

Fig. 76

Fig. 77

Fig. 78

Fig. 79

Fig. 80

Fig. 81

Fig. 82

Fig. 83

Fig. 84

Fig. 85

Fig. 86

Fig. 87

Fig. 88

Fig. 89

Fig. 90

Fig. 91

Fig. 92

Fig. 93

Fig. 94

Fig. 95

Fig. 96

Fig. 97

Fig. 98

Fig. 99

Fig. 100

Fig. 101

Fig. 102

Fig. 103

Fig. 104

Fig. 105

Fig. 106

Fig. 107

Fig. 108

Fig. 109

Fig. 110

Fig. 111

Fig. 112

Fig. 113

Fig. 114

Fig. 115

Fig. 116

Fig. 117

Fig. 118

Fig. 119

Fig. 120

Fig. 121

Fig. 122

Fig. 123

Fig. 124

Fig. 125

Fig. 126

Fig. 127

Fig. 128

Fig. 129

Fig. 130

Fig. 131

Fig. 132

Fig. 133

Fig. 134

Fig. 135

Fig. 136

Fig. 137

Fig. 138

Fig. 139

Fig. 140

Fig. 141

Fig. 142

Fig. 143

Fig. 144

Fig. 145

Fig. 146

Fig. 147

Fig. 148

Fig. 149

Fig. 150

Fig. 151

Fig. 152

Fig. 153

Fig. 154

Fig. 155

Fig. 156

Fig. 157

Fig. 158

Fig. 159

Fig. 160

Fig. 161

Fig. 162

Fig. 163

Fig. 164

Fig. 165

Fig. 166

Fig. 167

Fig. 168

Fig. 169

Fig. 170

Fig. 171

Fig. 172

Fig. 173

Fig. 174

Fig. 175

Fig. 176

Fig. 177

Fig. 178

Fig. 179

Fig. 180

Fig. 181

Fig. 182

Fig. 183

Fig. 184

Fig. 185

Fig. 186

Fig. 187

Fig. 188

Fig. 189

Fig. 190