

SPLIT TYPE AIR CONDITIONER Cassette Type INSTALLATION INSTRUCTION SHEET (PART NO. 9363217018)

For authorized service personnel only.

- WARNING**
This work indicates procedures which, if improperly performed, might lead to the death or serious injury of the user.
- CAUTION**
This work indicates procedures which, if improperly performed, might possibly result in personal harm to the user, or damage to property.
- WARNING**
For the air conditioner to operate satisfactorily, install it as outlined in this installation instruction sheet.
1. Connect the indoor unit and outdoor unit with the room air conditioner piping and cords available from our standard parts. This installation instruction sheet describes the correct connections using the installation set available from our standard parts.
2. Installation work must be performed in accordance with national wiring standards by authorized personnel only.
3. If refrigerant leaks while work is being carried out, ventilate the area. If the refrigerant comes in contact with a flame, it produces a toxic gas.
4. Do not turn on the power until all installation work is complete.

5. Be careful not to scratch the air conditioner when handling it.
6. After installation, explain correct operation to the customer, using the operating manual.
7. Let the customer keep this installation instruction sheet because it is used when the air conditioner is serviced or moved.
8. The maximum length of the piping is shown in Table 1. If the units are further apart than this, correct operation cannot be guaranteed.

STANDARD PARTS

The following standard parts are furnished. Use them as required.

Name and Shape	Qty	Application
Coupler heat insulation	2	For indoor unit pipe joint
Remote controller cord clamp	10	For installing the remote controller cord
Screw	10	For installing the remote controller cord clamp
Special nut A (large flange)	4	For installing indoor unit
Special nut B (small flange)	4	For installing indoor unit
Remote controller	1	Installation to indoor unit
Template	1	For ceiling hole cutting
Binder	2	For remote controller cord binding
Blower cover installation	2	For remote controller and blower cover cord binding
Hook wire	2	For installing intake grille

OUTDOOR UNIT ACCESSORIES

Power pipe	1	For power supply cord installation
Auxiliary pipe assembly	1	For wiring conduit pipe with connection (May not be required, depending on the model)
Edge cover	1	For wiring conduit installation (slant back edge protection)
Testing screw	2	For cabinet A and cabinet D mounting (1) (Spec. 11)
Binder	1	For power supply cord binding
Putty	1	For sealing
Coupler heat insulation	1	For outdoor side pipe joint
Pipe (drain)	2	For outdoor unit drain piping work (May not be required, depending on the model)
Flexible tube	2	For outdoor unit drain piping work (May not be required, depending on the model)
Cap (drain)	2	For outdoor unit drain piping work (May not be required, depending on the model)

SELECTING THE MOUNTING POSITION

The indoor unit mounting position is very important for the split type air conditioner because it is very difficult to move from place to place after the first installation.

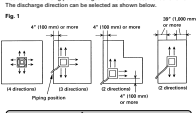

CAUTION
Since 2-way outlet is shown below causes performance problems, do not use it.

- INDOOR UNIT**
- Install the indoor unit on a place having a sufficient strength to support its weight.
 - The inlet and outlet pipes should not be obstructed; the air should be able to blow all over the room.
 - Leave the space required to service the air conditioner (Fig. 2).
 - The ceiling near height is shown in Fig. 2.
 - A place where the air can be distributed evenly throughout the room by the unit.
 - A place where the drainage can be extended outdoors easily.
 - Install the unit where noise and vibrations are not amplified.

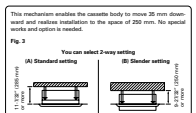
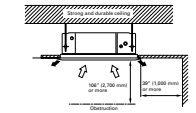

OUTDOOR UNIT

WARNING
Install the unit where it will not be tilted by more than 5°.

- When installing the outdoor unit where it may be exposed to strong wind, fasten it securely.

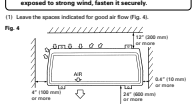

- If possible, do not install the unit where it will be exposed to direct sunlight. If necessary, install a shade that does not interfere with the air flow.
- Do not install the unit near a source of heat, steam, or flammable gas. During heating operation, drain water flows from the outdoor unit. Therefore, install the outdoor unit in a place where the drain water flow will not be obstructed. (Reverse cycle model only.)
- Do not install the unit where a strong wind blows or where it is very dusty.
- Do not install the unit where people pass.
- Install the outdoor unit in a place where it will be free from being hit or getting wet by rain as much as possible.
- Install the unit where connection to the indoor unit is easy.

CONNECTION PIPE REQUIREMENT

Outer diameter	Maximum length	Maximum height (between indoor and outdoor)
Small	166 ft (50 m)	98 ft (30 m)
Large	166 ft (50 m)	98 ft (30 m)

• Use 0.7 mm to 1.2 mm thick pipe.
• Use pipe with water-resistant heat insulation.
• Use pipe that can withstand a pressure of 3,040 kPa.

ELECTRICAL REQUIREMENT

Rated current (A)	MAX.	MIN.
Compressor	3.5	2.5
Fan motor	1.2	0.8
Full-load capacity (kW)	20	

• Always use 100V/115V or equivalent as the cord.
• Install the disconnect device with a contact gap of at least 2 mm, meeting the units both indoor unit and outdoor unit.

INSTALLATION PROCEDURE

1. INDOOR UNIT INSTALLATION

WARNING
Install the air conditioner in a location which can withstand a load of at least five times the weight of the main unit and which will not amplify sound or vibration. If the installation location is not strong enough, the indoor unit may fall and cause injury.

- If the job is done with the panel frame only, there is a risk that the unit will come loose. Please take care.

REMOVING THE INTAKE GRILLE

- Push the intake grille push-button three places.
- Open the intake grille.

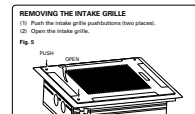

2. HANGING PREPARATIONS

- Remove the grille frame pins.

3. POSITIONING THE CEILING HOLE AND HANGING BOLTS

- Push the ceiling hole and hanging bolts.
- Finally fix the hanging bolts as shown in Fig. 13 or by another method.
- Install the hanging bolts at a place where they would be capable of holding a weight of at least 50 kgf per bolt.

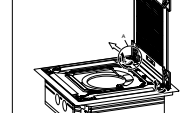

4. INSTALLING THE PANEL FRAME

- Push up the direction of the arrow while holding down the C section of Fig. 10, 16 location.

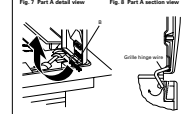

5. REMOVING THE PANEL FRAME

- Put up the corner sections (A) of the panel frame as shown in Fig. 9, 14 location.



3. BODY INSTALLATION

The ceiling near height is 17.32" (439 mm) or more. (Standard setting) (The ceiling near height is 21.32" (539 mm) or more.) (Slender setting)

- Install special nut A, then special nut B onto the hanging bolt (Fig. 10).
- Raise the body and mount to hooks onto the hanging bolt between the special nut (Fig. 10).
- Turn special nut B to adjust the height of the body (Fig. 15, 16). Leveling.
- Using a level, or vinyl hose filled with water, fine adjust so that the body is level.

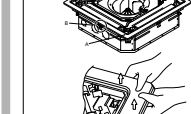

4. INSTALLING THE PANEL FRAME

- Push up the direction of the arrow while holding down the C section of Fig. 10, 16 location.

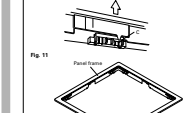

5. REMOVING THE PANEL FRAME

- Put up the corner sections (A) of the panel frame as shown in Fig. 9, 14 location.

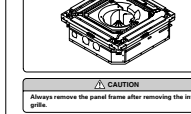

3. OUTDOOR UNIT INSTALLATION

1. OUTDOOR UNIT POSITIONING

- When the outdoor unit will be exposed to strong wind, fasten it with bolts on the four places indicated by the arrow (Fig. 21).
- Close the drain water flow out of the outdoor unit during heating operation. Install the drain pipe and connect it to a commercial 1.6 inch hose. (When heating when the outdoor temperature is 5°C or less, connected to the drain water drained from the outdoor unit will not freeze in the drain pipe.)
- When installing the drain pipe, plug the hole at the rear. Install the drain pipe mounting hole in the bottom of the outdoor unit with putty to there is no water leakage (Fig. 21).

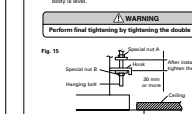

2. OUTDOOR UNIT CONNECTION CORD AND PIPE CORRECTION PREPARATIONS

- Pipe and connection cord mounting direction (4-way mounting possible).

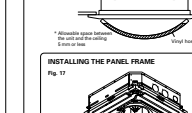

3. CONNECTION PIPES

1. Indoor unit side

- Remove outdoor unit cabinet A and cabinet D.

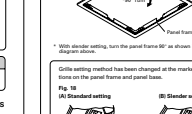

2. Outdoor unit side

- Be sure to apply the pipe against the port on the indoor unit correctly. If the connection is improper, the flare nut cannot be tightened smoothly. If the flare nut is forced to turn, the threads will be damaged.
- Do not remove the flare nut from the indoor unit pipe until immediately before connecting the connection pipe.

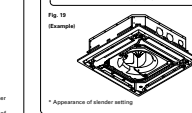

4. CONNECTING THE PIPING

1. FLARE PROCESSING

- Cut the connection pipe with pipe cutter so that the pipe is not deformed.
- Hold the pipe downward so that cuttings cannot enter the pipe, remove the burrs.
- Remove the flare nut from the indoor unit pipe and outdoor unit and assemble as shown in Fig. 26, 27 and insert the flare nut onto the pipe, and flare with Flare Tool.
- Check if the flare part "L" (Fig. 26) is spread uniformly and that there are no cracks.

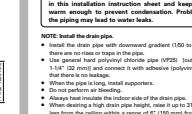

3. OUTDOOR UNIT INSTALLATION

1. OUTDOOR UNIT POSITIONING

- When the outdoor unit will be exposed to strong wind, fasten it with bolts on the four places indicated by the arrow (Fig. 21).
- Close the drain water flow out of the outdoor unit during heating operation. Install the drain pipe and connect it to a commercial 1.6 inch hose. (When heating when the outdoor temperature is 5°C or less, connected to the drain water drained from the outdoor unit will not freeze in the drain pipe.)
- When installing the drain pipe, plug the hole at the rear. Install the drain pipe mounting hole in the bottom of the outdoor unit with putty to there is no water leakage (Fig. 21).

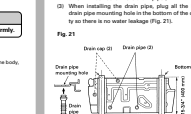

2. OUTDOOR UNIT CONNECTION CORD AND PIPE CORRECTION PREPARATIONS

- Pipe and connection cord mounting direction (4-way mounting possible).



3. CONNECTION PIPES

1. Indoor unit side

- Remove outdoor unit cabinet A and cabinet D.

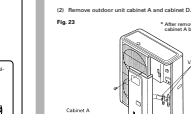

2. Outdoor unit side

- Be sure to apply the pipe against the port on the indoor unit correctly. If the connection is improper, the flare nut cannot be tightened smoothly. If the flare nut is forced to turn, the threads will be damaged.
- Do not remove the flare nut from the indoor unit pipe until immediately before connecting the connection pipe.

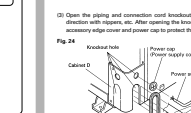

4. CONNECTING THE PIPING

1. FLARE PROCESSING

- Cut the connection pipe with pipe cutter so that the pipe is not deformed.
- Hold the pipe downward so that cuttings cannot enter the pipe, remove the burrs.
- Remove the flare nut from the indoor unit pipe and outdoor unit and assemble as shown in Fig. 26, 27 and insert the flare nut onto the pipe, and flare with Flare Tool.
- Check if the flare part "L" (Fig. 26) is spread uniformly and that there are no cracks.

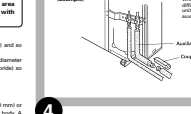

Table 1

Pipe	Flare nut
Small pipe	Small (width across flats 22 mm)
Large pipe	Large (width across flats 30 mm)

Table 2

Flare nut	Flare nut
Small pipe	Small (width across flats 22 mm)
Large pipe	Large (width across flats 30 mm)

2. BENDING PIPES

- The pipes are supported by your hands. Be careful not to collapse them.



3. CONNECTION PIPES

1. Indoor unit side

- Remove outdoor unit cabinet A and cabinet D.

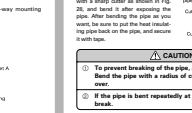

2. Outdoor unit side

- Be sure to apply the pipe against the port on the indoor unit correctly. If the connection is improper, the flare nut cannot be tightened smoothly. If the flare nut is forced to turn, the threads will be damaged.
- Do not remove the flare nut from the indoor unit pipe until immediately before connecting the connection pipe.

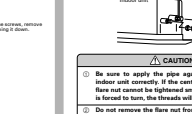

4. CONNECTING THE PIPING

1. FLARE PROCESSING

- Cut the connection pipe with pipe cutter so that the pipe is not deformed.
- Hold the pipe downward so that cuttings cannot enter the pipe, remove the burrs.
- Remove the flare nut from the indoor unit pipe and outdoor unit and assemble as shown in Fig. 26, 27 and insert the flare nut onto the pipe, and flare with Flare Tool.
- Check if the flare part "L" (Fig. 26) is spread uniformly and that there are no cracks.

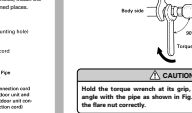

5

VACUUM PROCESS

1. VACUUM

- Vacuum inside the indoor unit and the piping to a pressure of 1.5 mmHg abs or less from the charging valve with a vacuum pump.
- After vacuuming inside the indoor unit and the piping, remove the cap of the two valves.
- Open the handle of the two valves from the closed state (Table 6).
- Tighten the cap of the two valves to the specified torque.

Table 5

Handle	Tightening torque	
	Large valve	Small valve
Handle	15 kgf·cm (1.47 N·m) or less	
Cap	150 to 200 kgf·cm (14.7 to 19.6 N·m)	

Table 6

Open valve state	Closed valve state

* If the handle is not fully open, performance will drop and an abnormal sound will be generated.

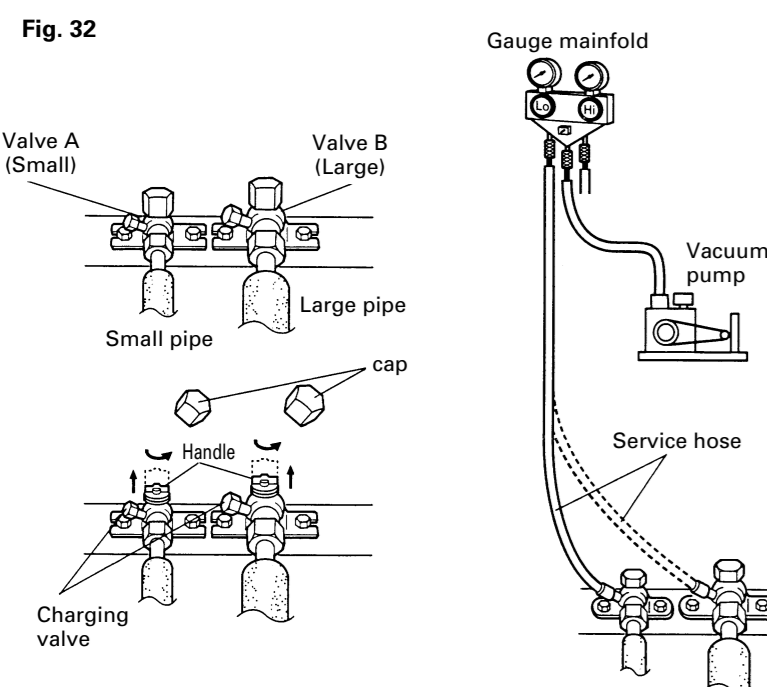

2. ADDITIONAL CHARGE

Refrigerant suitable for a piping length 20 m for other model is charged in the outdoor unit at the factory. When the piping is longer than 20 m, additional charging is necessary. For the additional amount, see the table below.

Table 7

Pipe length (20 m)	66 ft (20 m)	99 ft (30 m)	132 ft (40 m)	164 ft (50 m)	oz/ft (g/m)
Model type					
36,000 BTU class	None	14.1 oz (400 g)	28.2 oz (800 g)	42.3 oz (1200 g)	1.41 oz/3.3 ft (40 g/m)
54,000 BTU class	None	17.6 oz (500 g)	35.2 oz (1000 g)	52.8 oz (1500 g)	1.76 oz/3.3 ft (50 g/m)

CAUTION

- When charging the refrigerant, always use a measuring cylinder.
- Add refrigerant from the charging valve after the completion of the work.

6

INSTALLING THE COUPLER HEAT INSULATION

After checking for gas leaks, insulate by wrapping insulation around the two parts (large and small) of the indoor unit coupling, using the coupler heat insulation.

After installing the coupler heat insulation, wrap both ends with vinyl tape so that there is no gap.

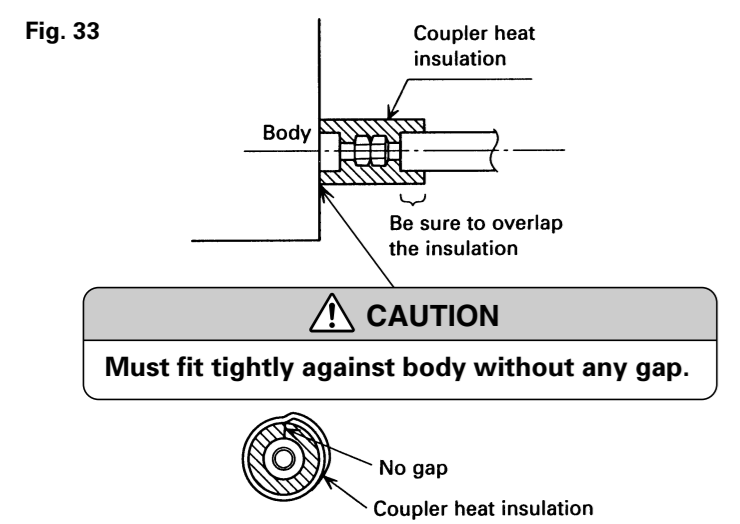

7

ELECTRICAL WIRING

HOW TO CONNECT WIRING TO THE TERMINALS

A. For solid core wiring (or F-cable)

- Cut the wire end with a wire cutter or wire-cutting pliers, then strip the insulation to about 15/16" (25 mm) of expose the solid wire.
- Using a screwdriver, remove the terminal screw(s) on the terminal board.
- Using pliers, bend the solid wire to form a loop suitable for the terminal screw.
- Shape the loop wire properly, place it on the terminal board and tighten securely with the terminal screw using a screwdriver.

B. For strand wiring

- Cut the wire end with a wire cutter or wire-cutting pliers, then strip the insulation to about 3/8" (10 mm) of expose the strand wiring.
- Using a screwdriver, remove the terminal screw(s) on the terminal board.
- Using a round terminal fastener or pliers, securely clamp a round terminal to each stripped wire end.
- Position the round terminal wire, and replace and tighten the terminal screw using a screwdriver.

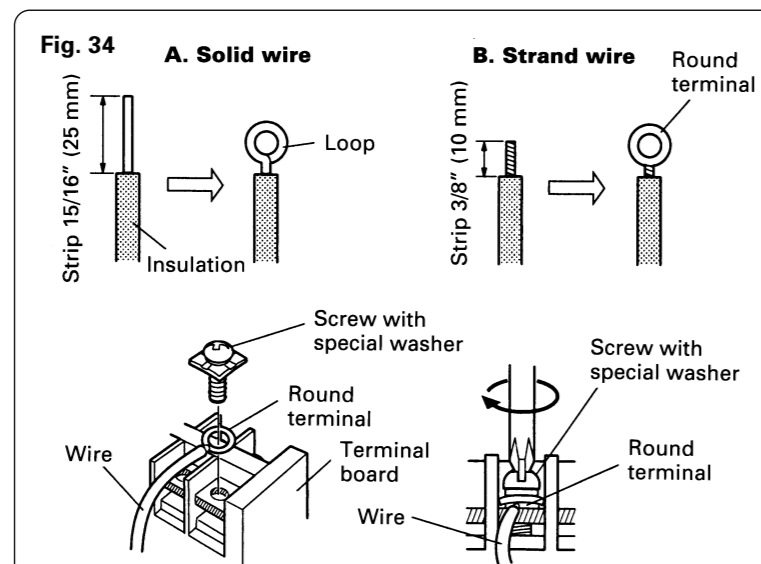

HOW TO FIXED CONNECTION CORD AND POWER SUPPLY CORD AT THE CORD CLAMP

After passing the connection cord and power supply cord through the insulation tube, fasten it with the cord clamp.

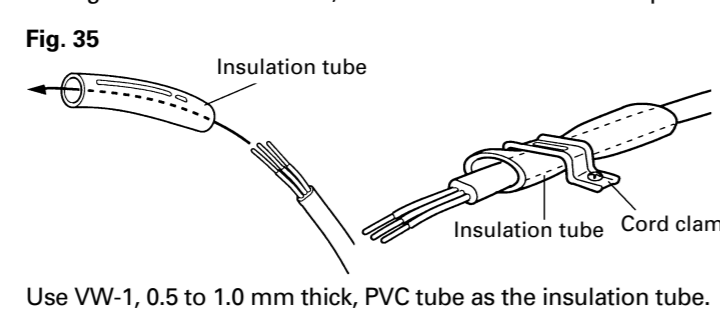

Use VV-1, 0.5 to 1.0 mm thick, PVC tube as the insulation tube.

1. INDOOR UNIT SIDE

WARNING

- Before starting work, check that power is not being supplied to the indoor unit.
- Match the terminal board numbers and connection cord colors with those of the outdoor unit. Erroneous wiring may cause burning of the electric parts.
- Connect the connection cord firmly to the terminal board. Imperfect installation may cause a fire.
- Always fasten the outside covering of the connection cord with the cord clamp. (If the insulator is chafed, electric leakage may occur.)
- Always connect the ground wire.

- Remove the control box cover and cover (wire) B and install the connection cord.

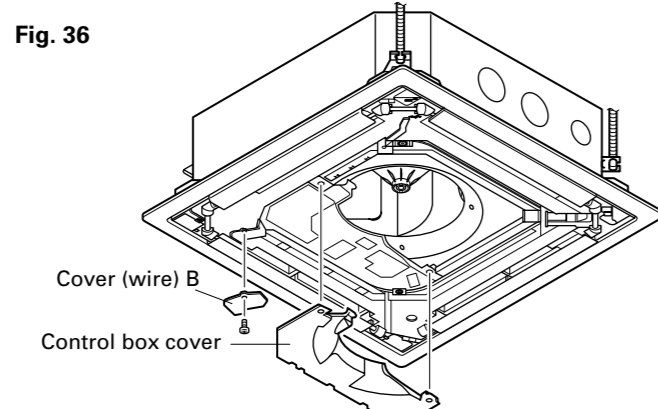

- After wiring is complete, clamp the remote controller cord and connection cord with the cord clamp.
- Install the control box cover and cover (wire) B.

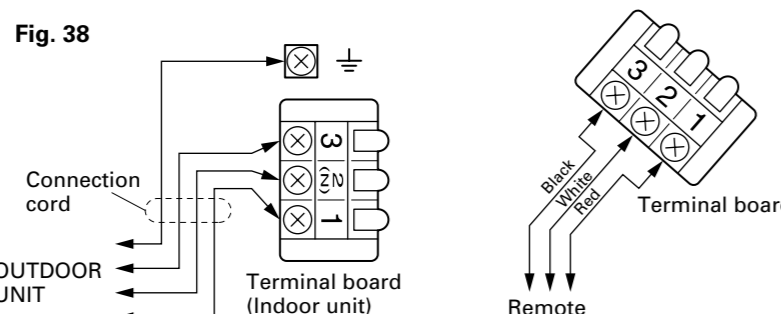
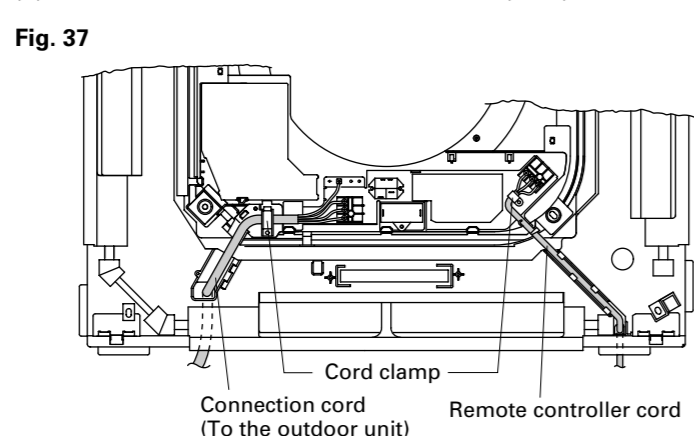

Ceiling height setting

Set the DIP switch for the ceiling height according to the table below.

Table 8

Ceiling height (m)		DIP-SW4		
		1	2	3
2.5 ~ 3.0	Normal	—	OFF	OFF
3.0 ~ 3.5	High ceiling 1	—	ON	OFF
More than 3.5	High ceiling 2	—	OFF	ON
Less than 2.5	Low ceiling	—	ON	ON

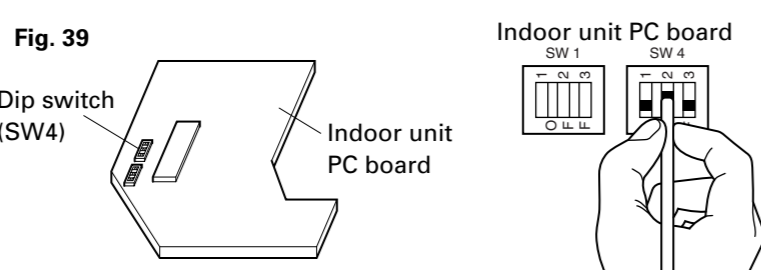

CAUTION

- If the setting for a low ceiling is selected, the capacity of the air conditioner decreases slightly.
- Do not set any switches other than those specified in this sheet or the remote controller installation instruction sheet. The air conditioner may not operate correctly if any switches other than those specified are changed.

2. OUTDOOR UNIT SIDE

WARNING

- Before starting work, check that power is not being supplied to the outdoor unit.
- Match the terminal board numbers and connection cord colors with those of the indoor unit side. Erroneous wiring may cause burning of the electric parts.
- Connect the connection cords and the power supply cord firmly to the terminal board. Imperfect installation may cause a fire.
- Always fasten the outside covering of the connection cord and the power supply cord with cord clamps. (If the insulator is chafed, electric leakage may occur.)
- Always connect the ground wire.

- Remove outdoor unit cabinet A and connect the power supply cord and the outdoor unit connection cord wired at the indoor unit.
- Fasten the power supply cord and connection cord with cable clip and binders as shown in (Fig. 42).

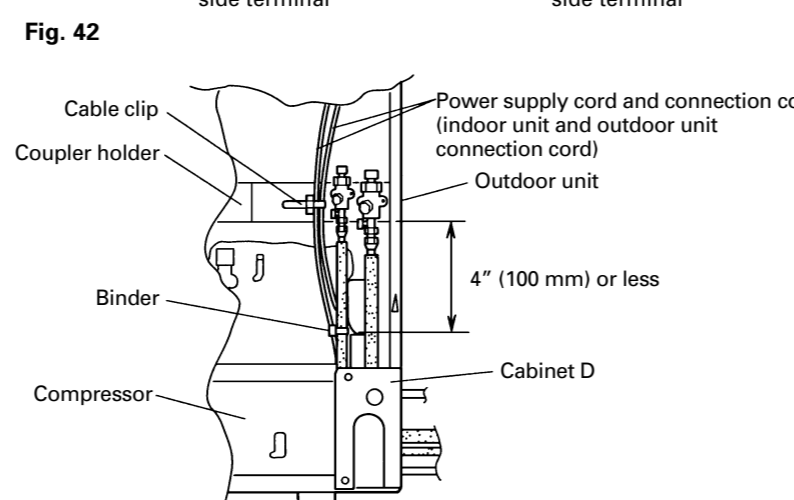
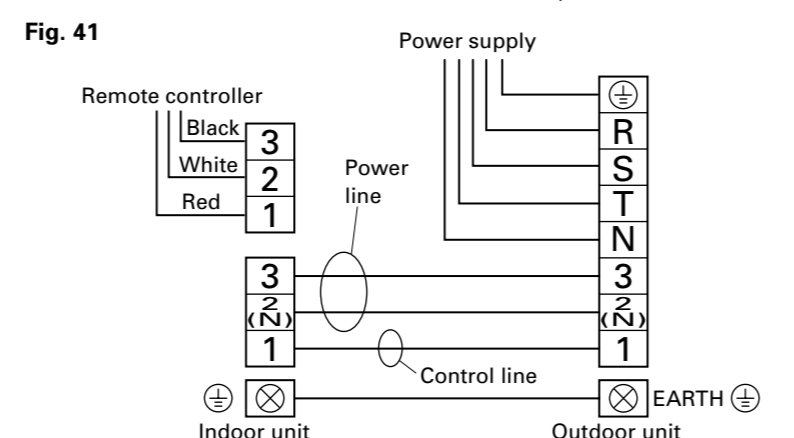
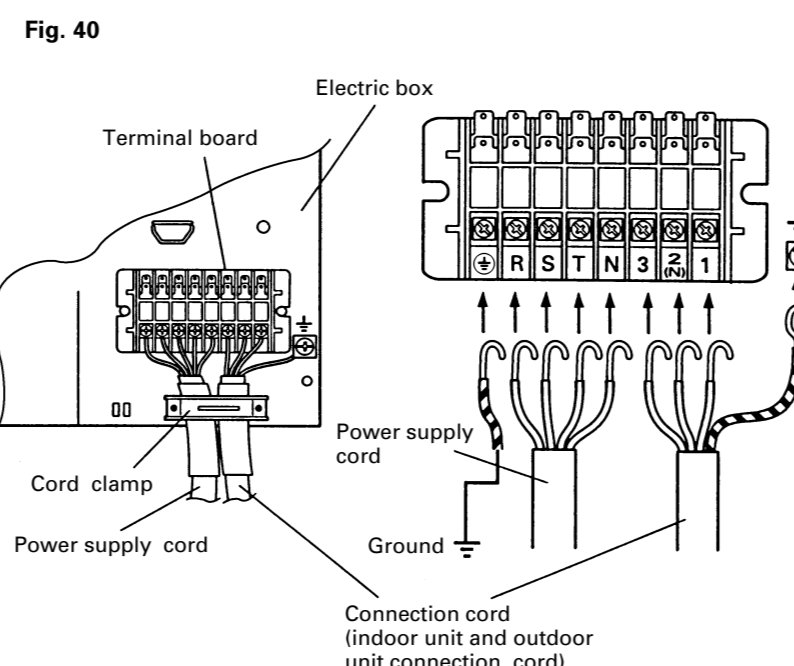

8

GRILLE INSTALLATION

BLOWER COVER INSULATION

Install the blower cover insulation only when the outlet direction is not specified. Two blower cover insulations are packed with the indoor unit. Install the blower cover insulation at the diffuser position shown in Fig. 43. At this time, use the piping position as the criteria.

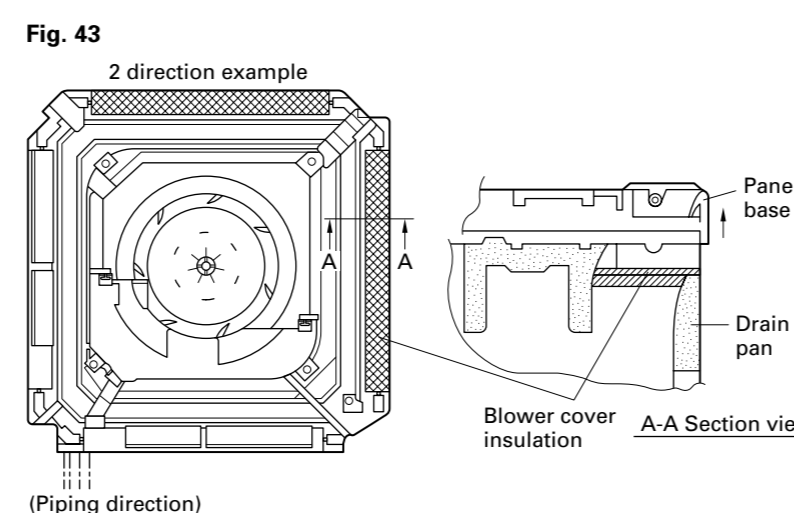

INSTALLING THE INTAKE GRILLE

- Mount the grille hinge wire to the hook shaft as shown in Fig. 44.

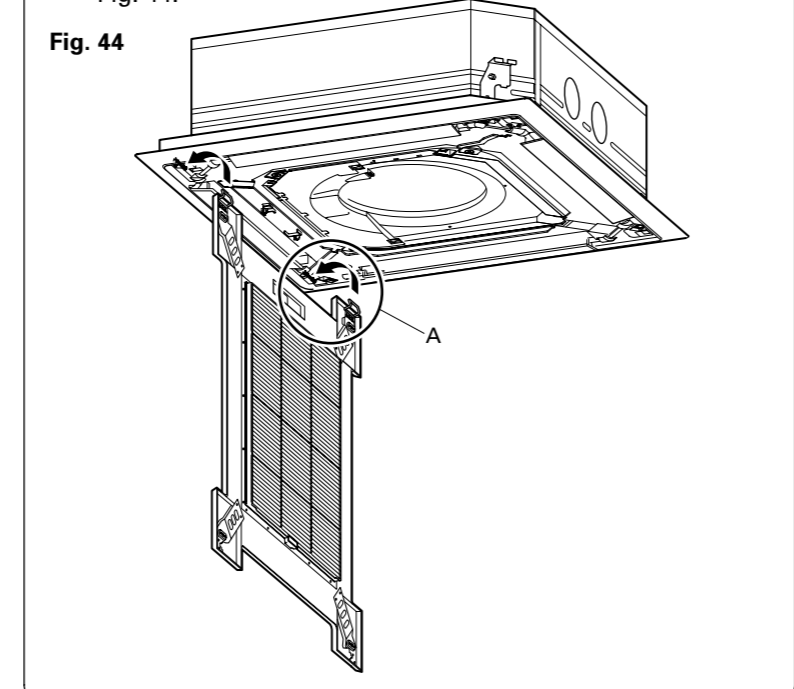

10

REMOTE CONTROLLER INSTALLATION

- Latch the grille hinge wire to the hook shaft, and fasten.

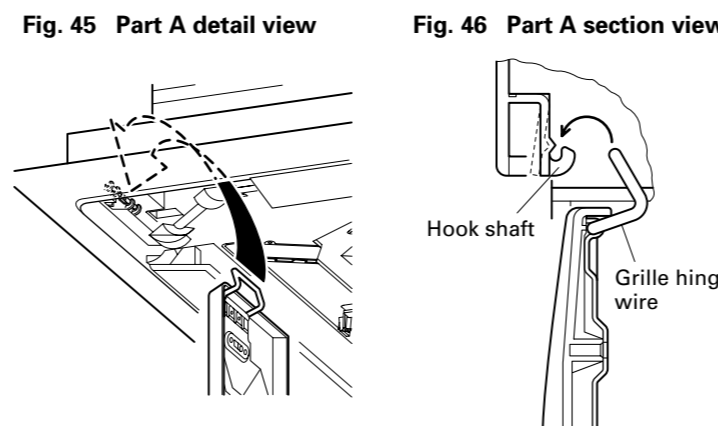

- Install the hook wire.

- Pass the hook wire through the panel base from the rear side as shown in Fig. 47, and fasten to the reinforced metal fitting of the intake grille using a screw.

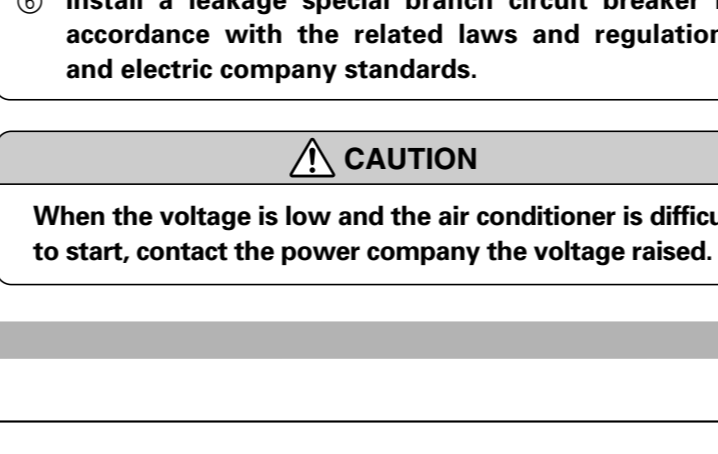
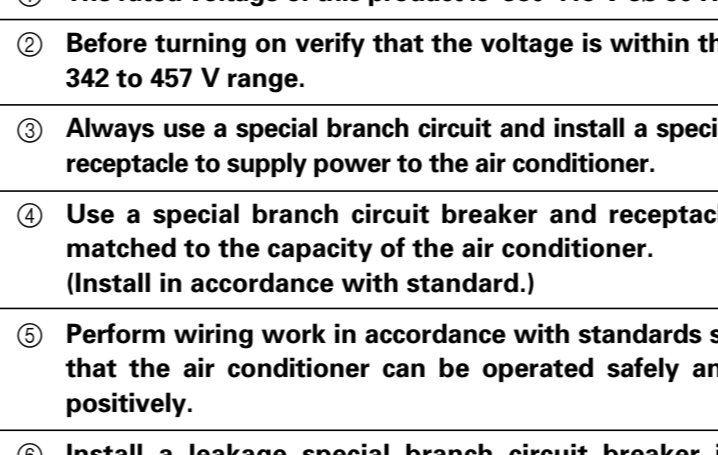
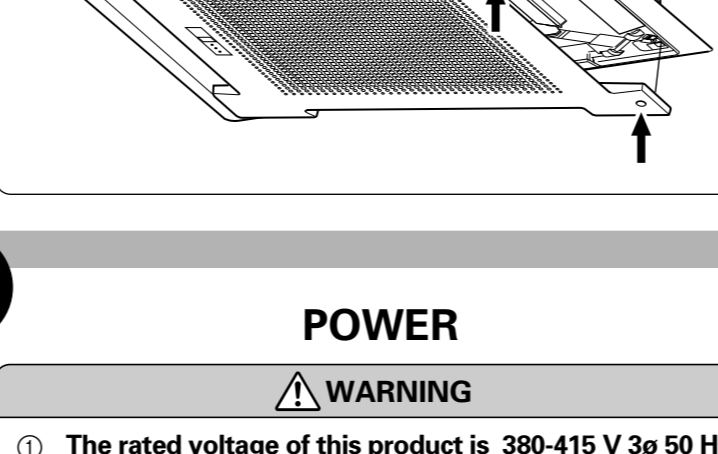
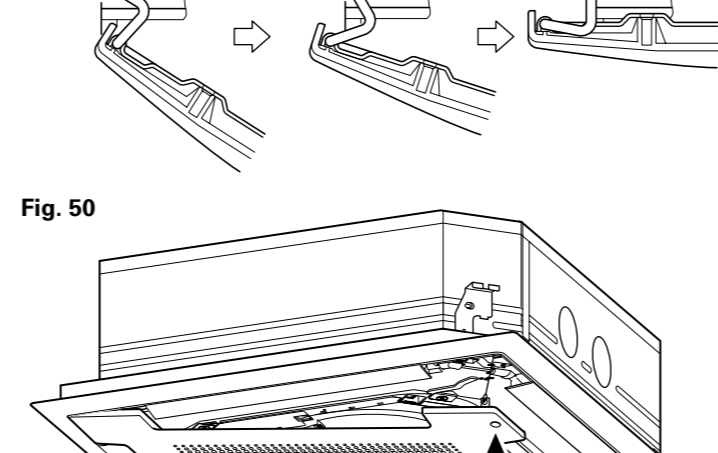
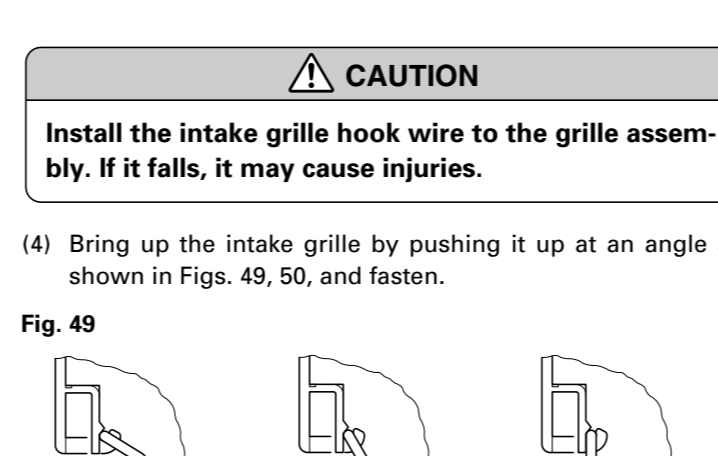
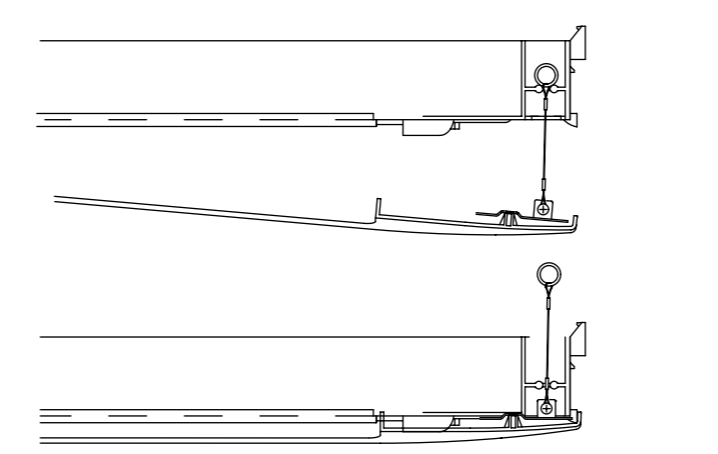
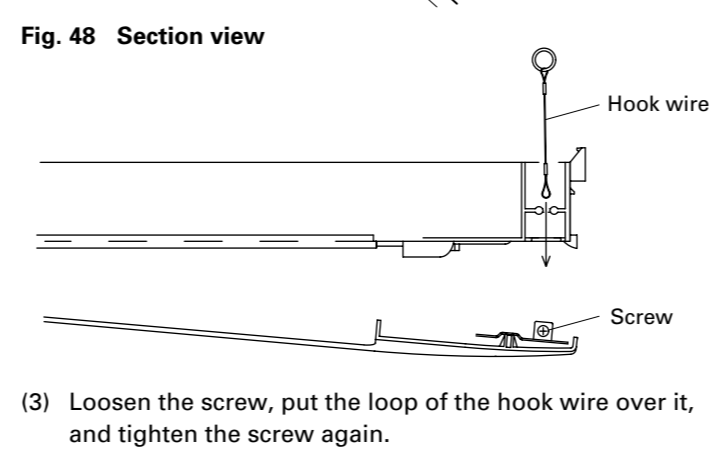
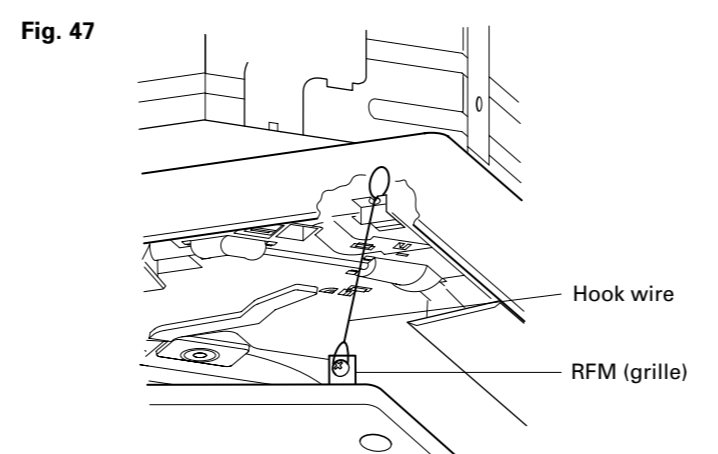

POWER

WARNING

- The rated voltage of this product is 380-415 V 3φ 50 Hz.
- Before turning on verify that the voltage is within the 342 to 457 V range.
- Always use a special branch circuit and install a special receptacle to supply power to the air conditioner.
- Use a special branch circuit breaker and receptacle matched to the capacity of the air conditioner. (Install in accordance with standard.)
- Perform wiring work in accordance with standards so that the air conditioner can be operated safely and positively.
- Install a leakage special branch circuit breaker in accordance with the related laws and regulations and electric company standards.

CAUTION

When the voltage is low and the air conditioner is difficult to start, contact the power company the voltage raised.

11

TEST RUNNING

1. REMOTE CONTROLLER

- Supply power to the crankcase heater 12 hours before the start of operation in the winter.
- For test running, when the remote controller FAN CONTROL button and MASTER CONTROL button are pressed simultaneously for more than three seconds when the air conditioner is not running, the air conditioner starts and TEST is displayed on the remote controller display.
- However, the SET TEMP./DAY setting button does not function, but all other buttons, displays, and protection functions operate (Fig. 55).

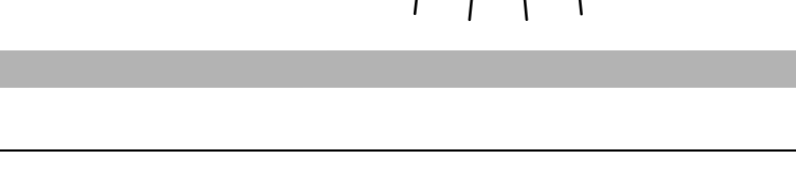
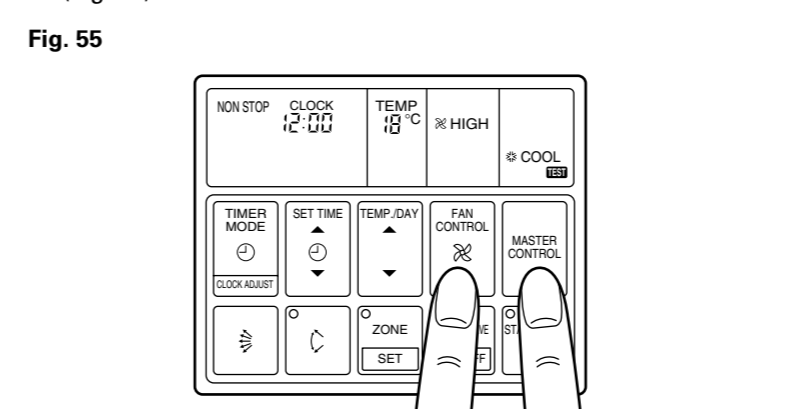

12

OPENING THE DUCT CONNECTION HOLE

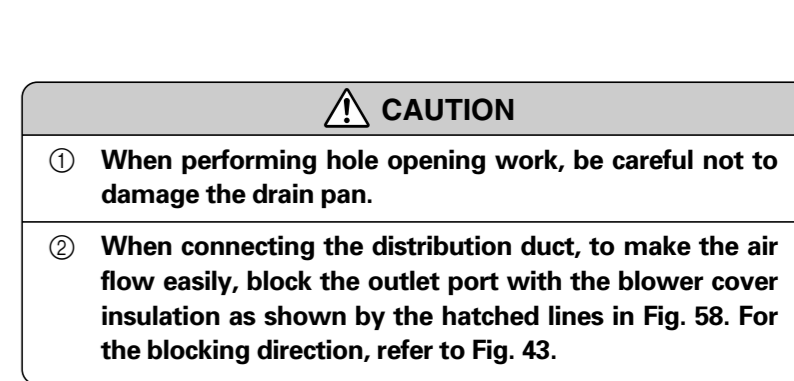
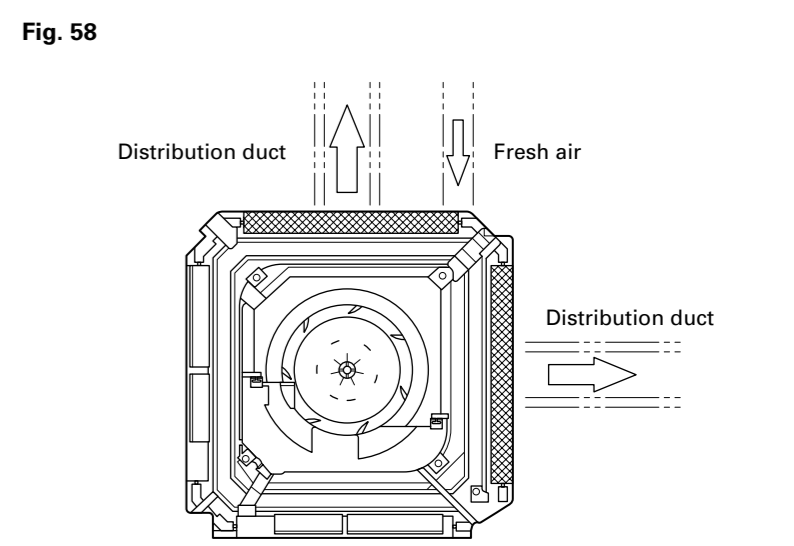

1. DIMENSION

Screw position and connection hole which are fresh air duct and distribution duct.

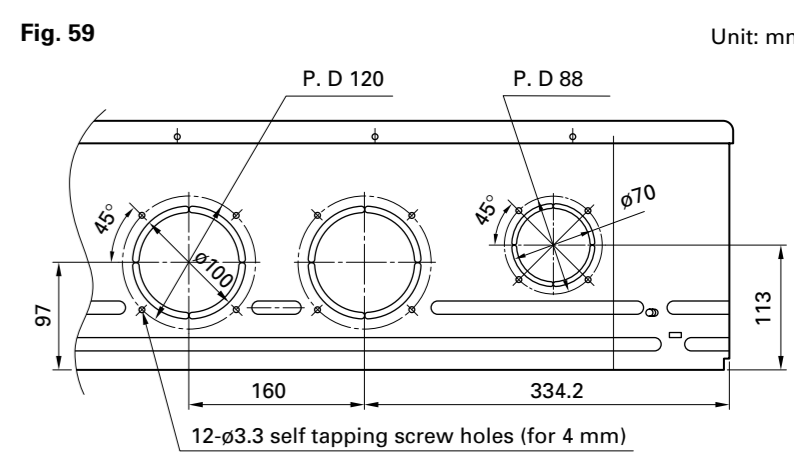

2. DISTRIBUTION DUCT AND FRESH AIR DUCT HOLE PROCESSING

Use the distribution duct hole and fresh air duct hole by removing the insulation material as shown below.

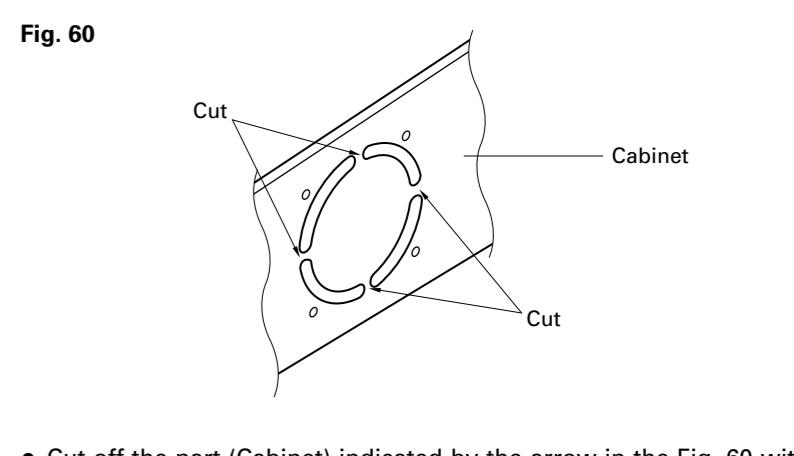

- Cut off the part (Cabinet) indicated by the arrow in the Fig. 60 with nippers, needle nose pliers, etc.

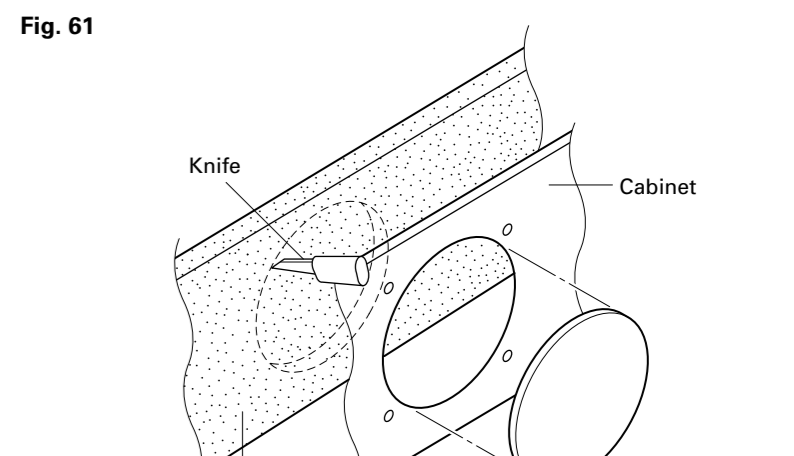

- Open the holes and cut the insulation with a knife.
 - Be careful not to damage the internal parts.
 - Be careful not to cut yourself on the cutout in the metal plate.
 - Please remove the insulation (inner box) left over after cutting.
- Connect the distribution duct.
 - When mounting the duct, block the gap so that there is no cold air leakage.
 - Insulate the duct and cut connection.

CAUTION

The air conditioner cannot take in fresh air by itself. When connecting a fresh air duct, always use a duct fan.

- When EE:EE blinks at the current time display, there is an error inside the air conditioner. If the SET TIME button (↔) and SET TEMP./DAY button (↔) are pressed simultaneously for more than three seconds, the self diagnosis check will start and the error contents will be displayed at the current time display (Fig. 56). When the operation lamp lights, press the START/STOP button and after operation lamp goes off, perform the same operation (Fig. 56). Process the error contents by referring to (Table 9).

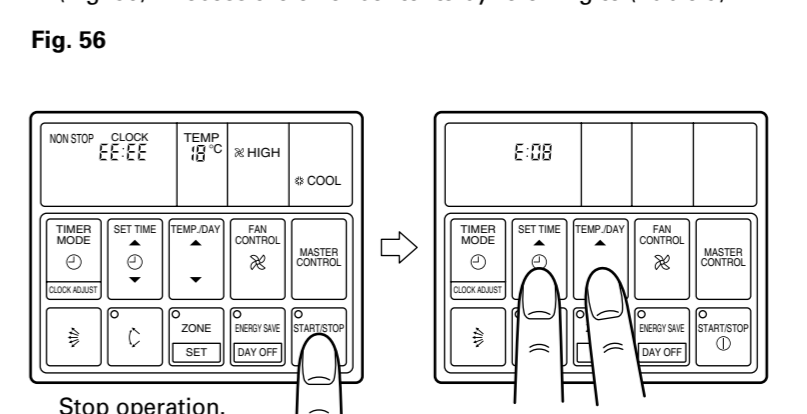

Table 9

Error code	Error contents
E:00	Communication error (indoor unit ↔ remote controller)
E:01	Communication error (indoor unit ↔ outdoor unit)
E:02	Room temperature sensor open
E:03	Room temperature sensor shorted
E:04	Indoor heat exchanger temperature sensor open
E:05	Indoor heat exchanger temperature sensor shorted
E:06	Outdoor heat exchanger temperature sensor open
E:07	Outdoor heat exchanger temperature sensor shorted
E:08	Power source connection error
E:09	Float switch operated
E:0A	Outdoor temperature sensor open
E:0B	Outdoor temperature sensor shorted
E:0C	Discharge pipe temperature sensor open
E:0D	Discharge pipe temperature sensor shorted
E:0E	Outdoor high pressure abnormal
E:0F	Discharge pipe temperature abnormal
E:11	Model abnormal
E:12	Indoor fan abnormal
E:13	Outdoor signal abnormal
E:14	Outdoor EEPROM abnormal

2. OUTDOOR UNIT

When the outdoor temperature drops, the outdoor unit's fans may switch to low speed, or one of the fans may stop intermittently.

ERROR

The LED lamps operate as follows (Table 10) according to the error contents.

Table 10

Error contents	LED1	LED2	LED3	LED4	LED5	LED6
Signal abnormal	—	—	×	○	×	×
Indoor unit abnormal	—	—	×	×	○	×
Discharge pipe temperature abnormal	—	—	×	×	×	○
Outdoor heat exchanger temperature abnormal	—	—	×	×	○	○
Outdoor temperature abnormal	—	—	×	○	×	○
Power source connection error	—	—	○	×	×	×
EEPROM abnormal	—	—	○	○	○	○
Outdoor high pressure abnormal	○	○	—	—	—	—
Discharge pipe temperature abnormal	—	○	—	—	—	—

○: 0.5s ON/0.5s OFF (flash) ×: OFF
○: 0.1s ON/0.1s OFF (flash) —: Indefinite

When the fault is cleared, the LED lamp goes off. However, for discharge pipe temperature abnormal and high pressure abnormal, the LED lamp lights continuously for 24 hours, as long as the power is not turned off.

3. CHECKING DRAINAGE

To check the drain, remove the water cover and fill with 2 to 3 l of water as shown in Fig. 57.

