

FUJII
ELECTRIC

SPLIT TYPE
AIR CONDITIONER

CASSETTE type (50Hz)

SERVICE
MANUAL

Models	Indoor unit	Outdoor unit
	RCW-12HA	RO-12HB

C O N T E N T S

SPECIFICATIONS	1
OUTLINE AND DIMENSIONS	3
CIRCUIT DIAGRAM	5
REFRIGERANT SYSTEM DIAGRAM	6
ERROR CONTENTS	7
INDOOR PRINTED CIRCUIT BOARD CIRCUIT DIAGRAM	8
DISASSEMBLY ILLUSTRATION	9
PARTS LIST	16

S P E C I F I C A T I O N S

TYPE		COOL & HEAT
INDOOR UNIT		RCW-12HA
OUTDOOR UNIT		RO-12HB
COOLING CAPACITY	(kW)	3.55 - 3.60
HEATING CAPACITY	(kW)	4.00 - 4.10

ELECTRICAL DATA

POWER SOURCE	(V)		220 - 240V
FREQUENCY	(Hz)		50
RUNNING CURRENT	(A)	COOLING	5.9 - 6.1
		HEATING	5.7 - 5.8
INPUT WATTS	(kW)	COOLING	1.26 - 1.34
		HEATING	1.20 - 1.28
E.E.R.	(kW/kW)	COOLING	2.82 - 2.69
		HEATING	3.33 - 3.20
STARTING CURRENT	(A)		35
MOISTURE REMOVAL	(ℓ /hr)		1.6
AIR CIRCULATION-Hi	(m³/hr)		550
REFRIGERANT	R-22 (g)		1,100

COMPRESSOR

TYPE		Hermetic type
CODE		RH231VHAT 220 - 240V 50Hz

FAN MOTOR

POWER SOURCE	(V)		240
INDOOR UNIT	TYPE		MFA-14GTCT
	HI-SPEED	(r.p.m.)	730
	MED-SPEED	(r.p.m.)	670
	LO-SPEED	(r.p.m.)	590
OUTDOOR UNIT	TYPE		MFB-14NTT
	HI / LO	(r.p.m.)	740 / 440

DIMENSIONS

INDOOR UNIT	H x W x D (mm)		235 x 580 x 580 +70
OUTDOOR UNIT			530 x 750 x 250
GRILLE			35 x 650 x 650

WEIGHT

INDOOR UNIT	GROSS / NET (kg)		23 / 18
OUTDOOR UNIT			39 / 37
GRILLE			4.3 / 2.2

MODELS				RCW-12HA
				RO-12HB
REFRIGERANT CIRCUIT	DISCHARGE PRESSURE	kg/cm ² G	COOLING	21.0
			HEATING	22.0
	SUCTION PRESSURE	kg/cm ² G	COOLING	5.5
			HEATING	4.4
	DISCHARGE TEMP.	°C	COOLING	80
			HEATING	78
REFRIG. PIPE LENGTH		m	7.5	
DISCHARGE AIR TEMP.	°C	COOLING	13	
		HEATING	42	
CONDITION	INDOOR ENTERING AIR TEMP.	DB/WB °C	COOLING	27.0 / 19.0
			HEATING	20.0 / —
	OUTDOOR ENTERING AIR TEMP.	DB/WB °C	COOLING	35.0 / 24.0
			HEATING	7.0 / 6.0
PIPING	PIPE DIA. SIZE	LIQUID	mm	6.35
		GAS		12.7
	CONNECTION METHOD			Flare
	BETWEEN	HEIGHT	m	Max. 8
PIPE LENGTH		Max. 20		
REFRIGERANT TYPE				R-22

REFRIGERANT CHARGE (R-22)

MODELS		PIPE LENGTH				Additional refrigerant
		7.5 m	10 m	15 m	20 m	
FULL CHARGE AMOUNT	RCW-12HA	1,100 g	1,138 g	1,213 g	1,288 g	15 g / m

OUTLINE AND DIMENSIONS

INDOOR UNIT

(unit : mm)

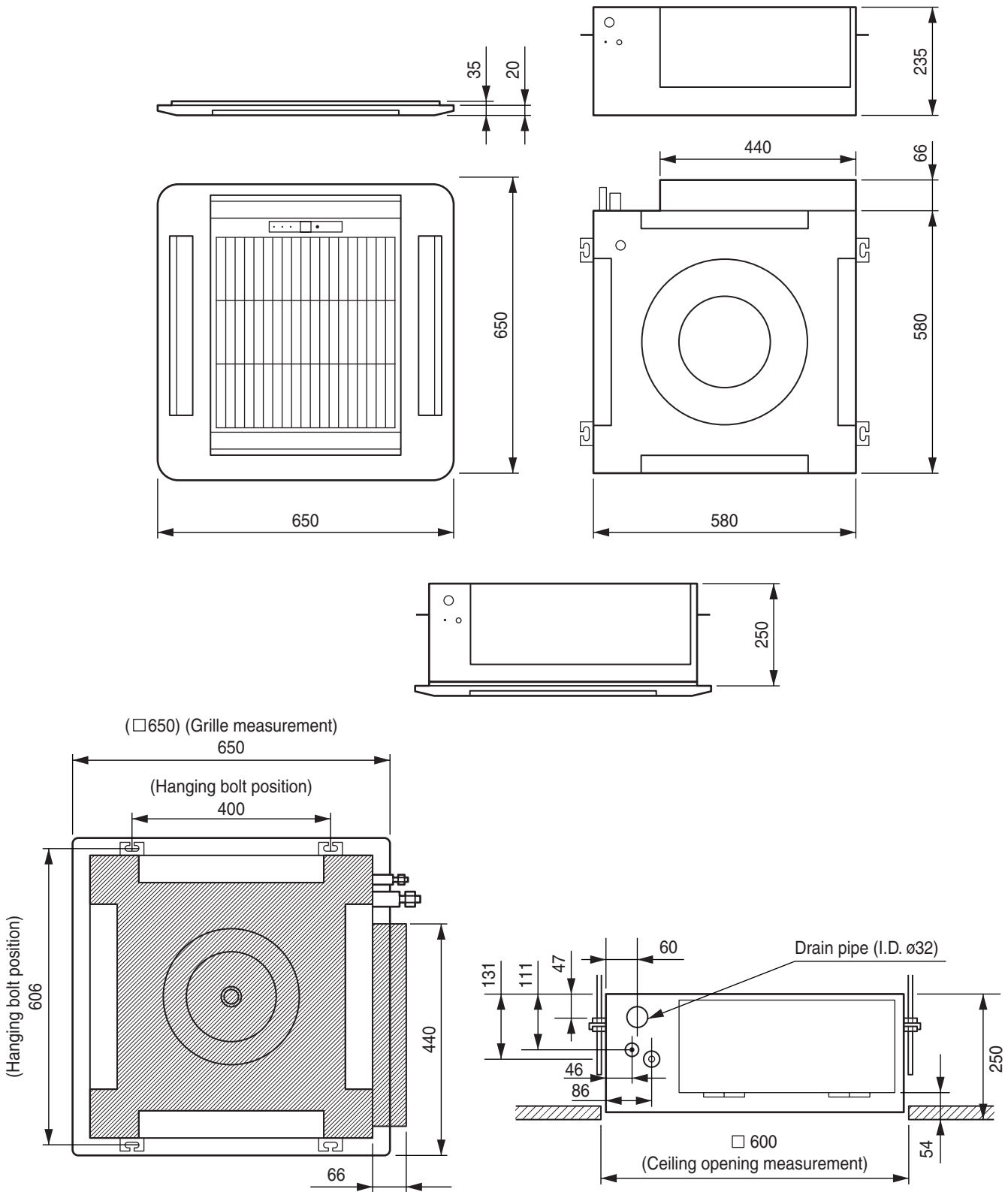

OUTDOOR UNIT

(unit : mm)

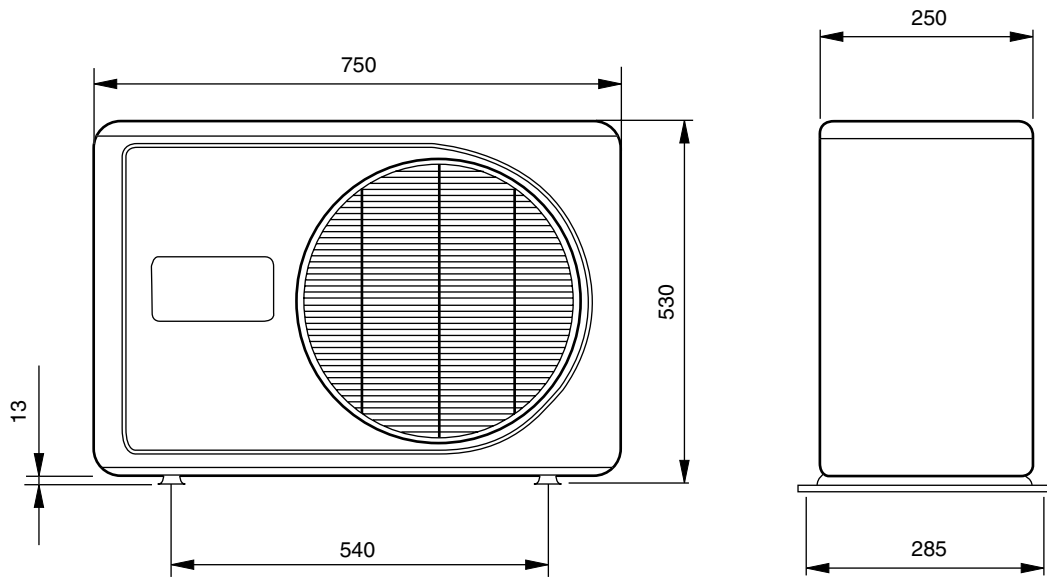

CIRCUIT DIAGRAM

Model : RCW-12HA

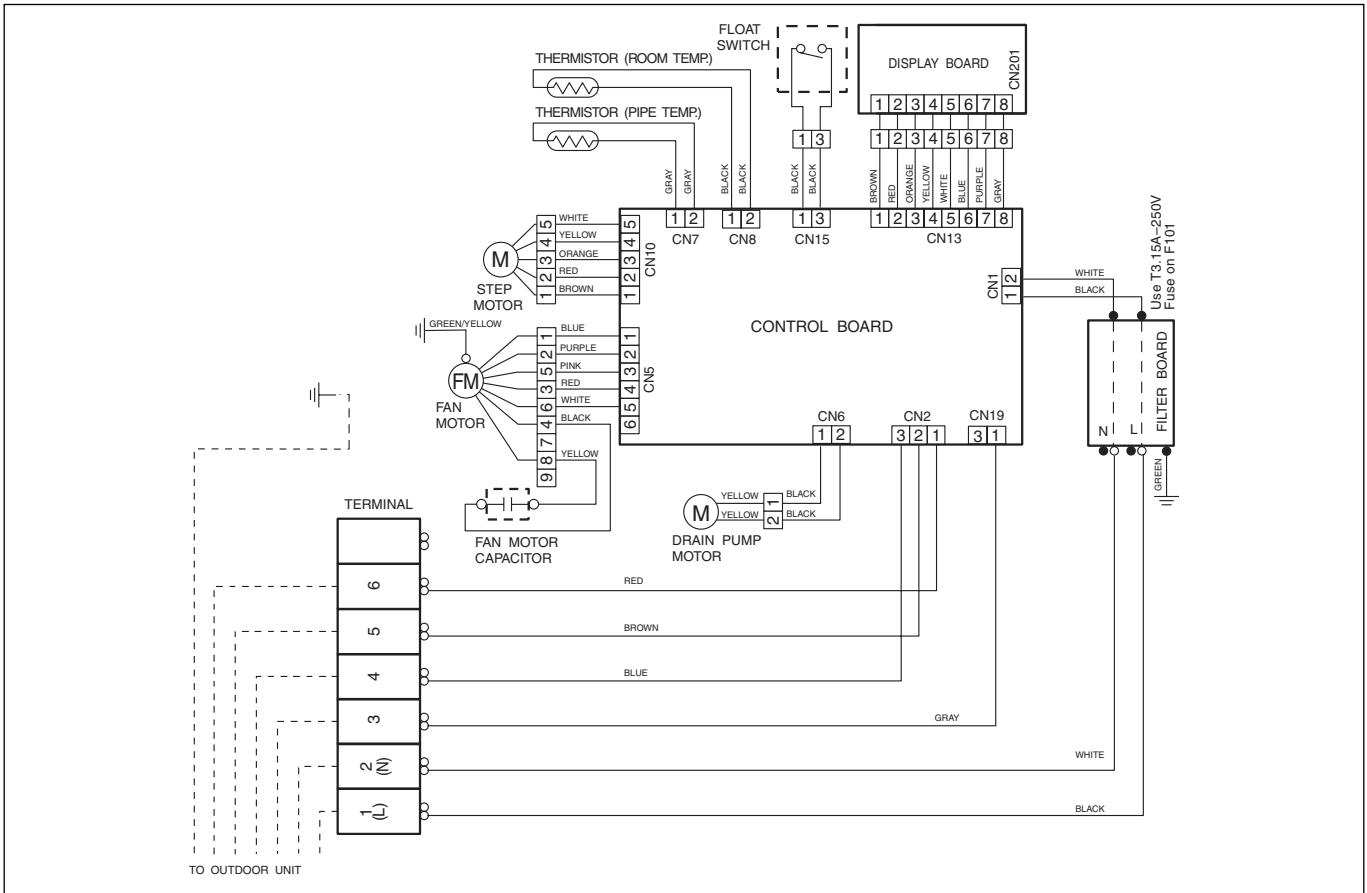

Model : RO-12HB

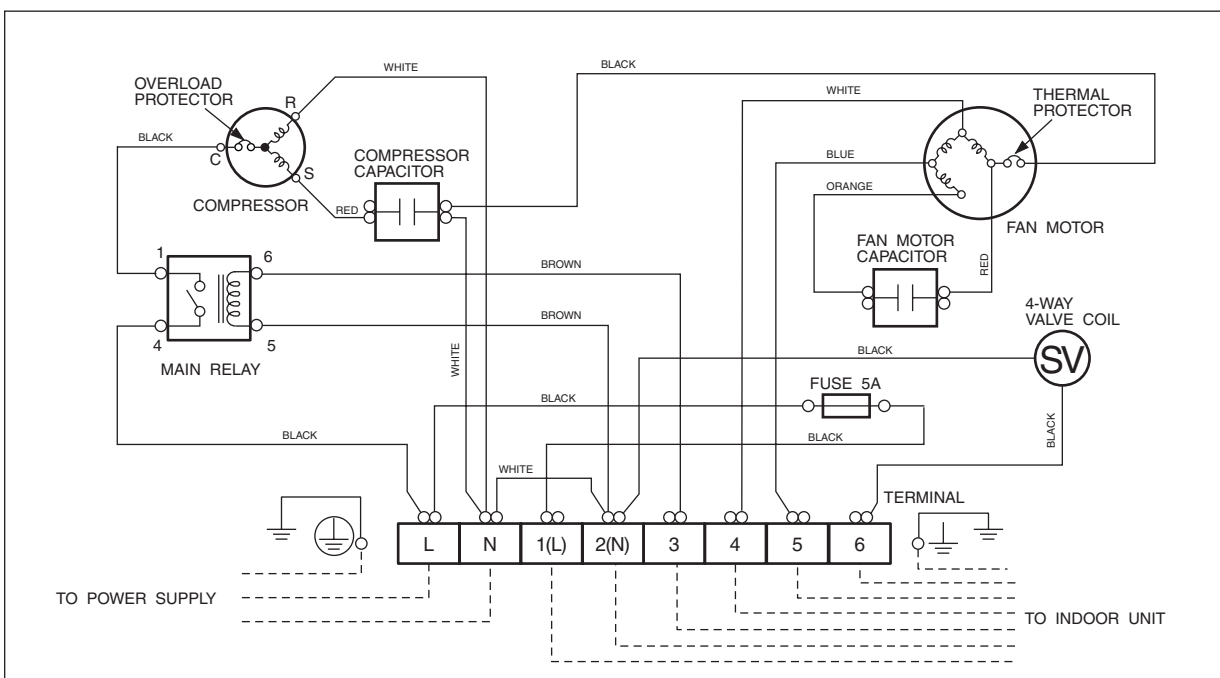

REFRIGERANT SYSTEM DIAGRAM

Models : RCW-12HA / RO-12HB

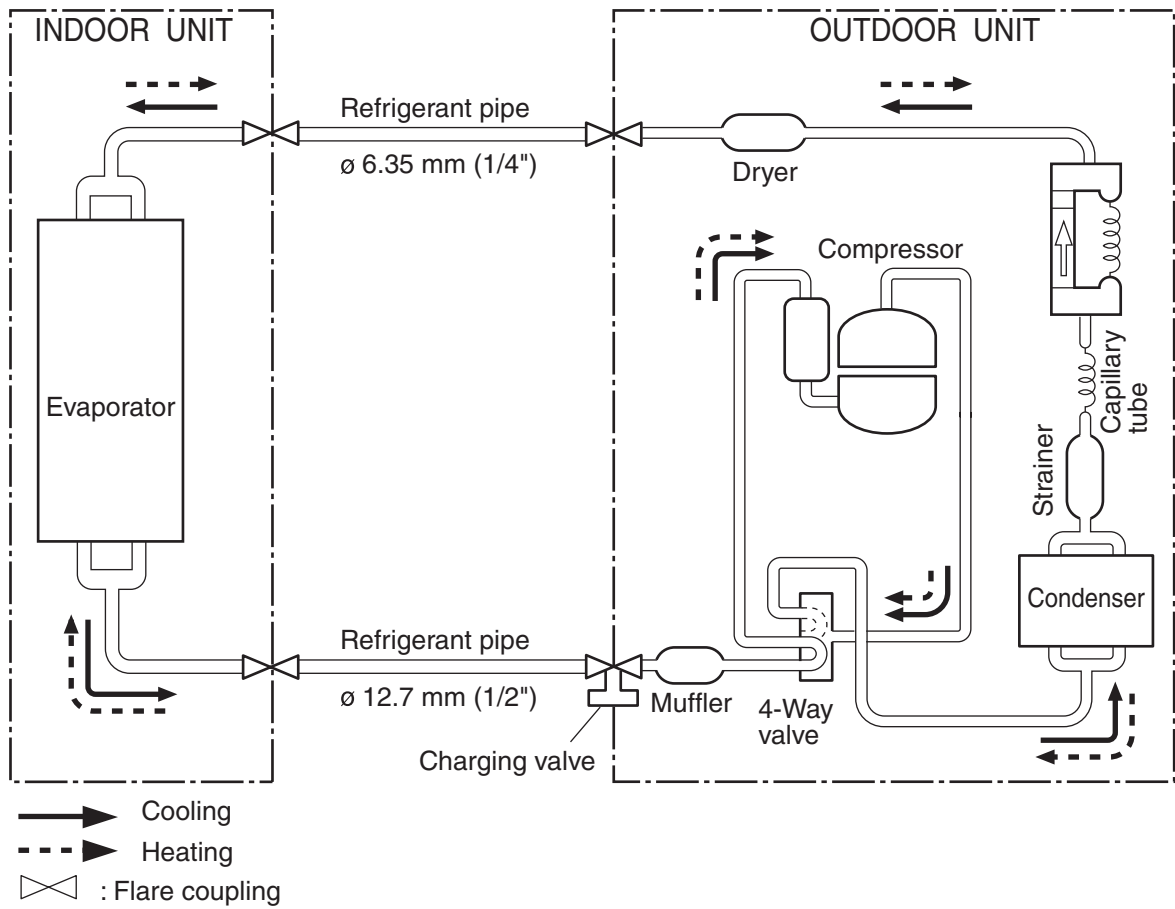

ERROR CONTENTS

Operation can be checked by lighting and flashing of the grille display section OPERATION and TIMER lamps.

Perform judgment in accordance with the following.

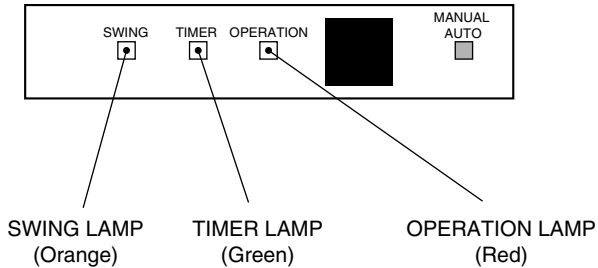

TEST RUNNING

When the air conditioner is run by pressing the remote control unit test run button, the OPERATION and TIMER lamps flash slowly at the same time.

ERROR

The OPERATION, TIMER, and SWING lamps operate as follows (Table 1) according to the error contents.

Table 1

Error display			Error contents
OPERATION lamp	TIMER lamp	SWING lamp	
Blinks	Blinks	Goes off	Model information abnormal (permanent type)
Pulses 4 times	Blinks	Goes off	Drain abnormal (permanent type)
Pulses 6 times	Blinks	Goes off	Indoor fan abnormal
Pulses 2 times	Blinks	Goes off	Room air temperature thermistor open circuit
		Blinks	Room air temperature thermistor short circuit
Pulses 3 times	Blinks	Goes off	Piping thermistor open circuit
		Blinks	Piping thermistor short circuit

CHECK ITEMS

1. INDOOR UNIT

- (1) Is operation of each button on the remote control unit normal?
- (2) Does each lamp light normally?
- (3) Do not air flow direction louvers operate normally?
- (4) Is the drain normal?
- (5) Is there any abnormal noise and vibration during operation?

2. OUTDOOR UNIT

- (1) Is there any abnormal noise and vibration during operation?
 - (2) Will noise, wind or drain water from the unit disturb the neighbors?
 - (3) Is there any gas leakage?
- Do not operate the air conditioner in the test running state for a long time.

INDOOR PRINTED CIRCUIT BOARD CIRCUIT DIAGRAM

Model : RCW-12HA

CONTROLLER PCB ASSEMBLY (MAIN PCB)
EZ-00327HSE-C

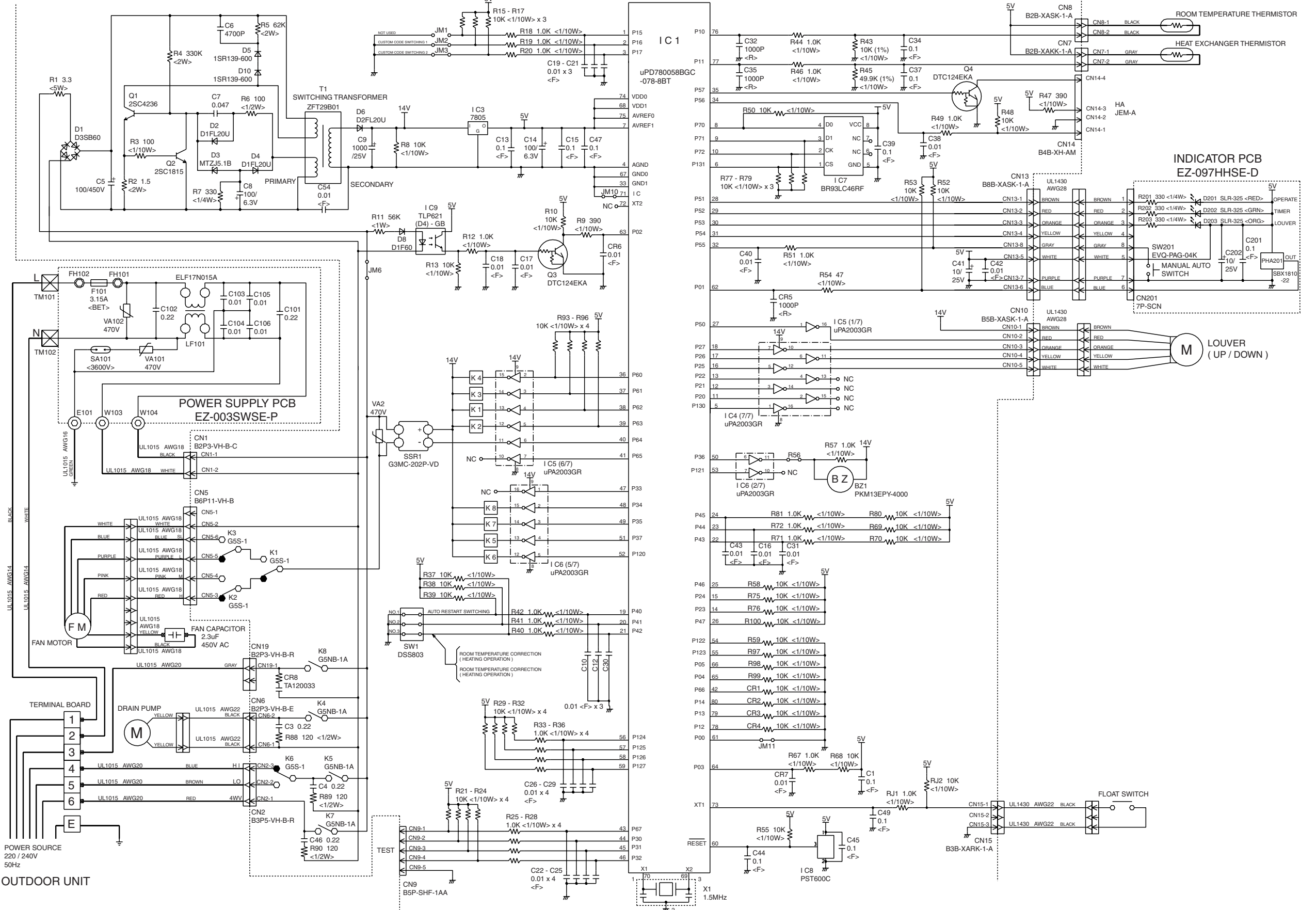

DISASSEMBLY ILLUSTRATION

Model : RCW-12HA

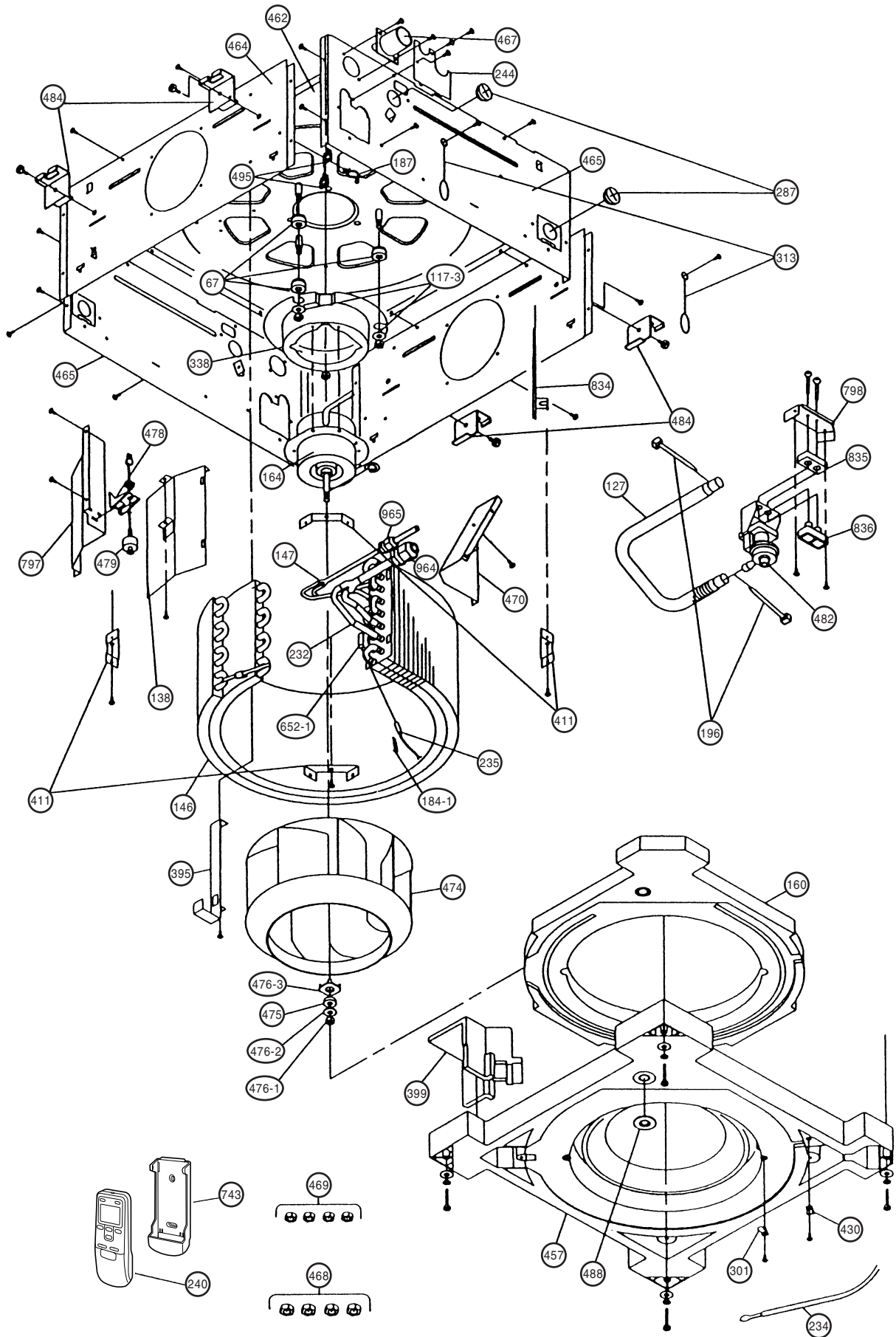

Model : RCW-12HA

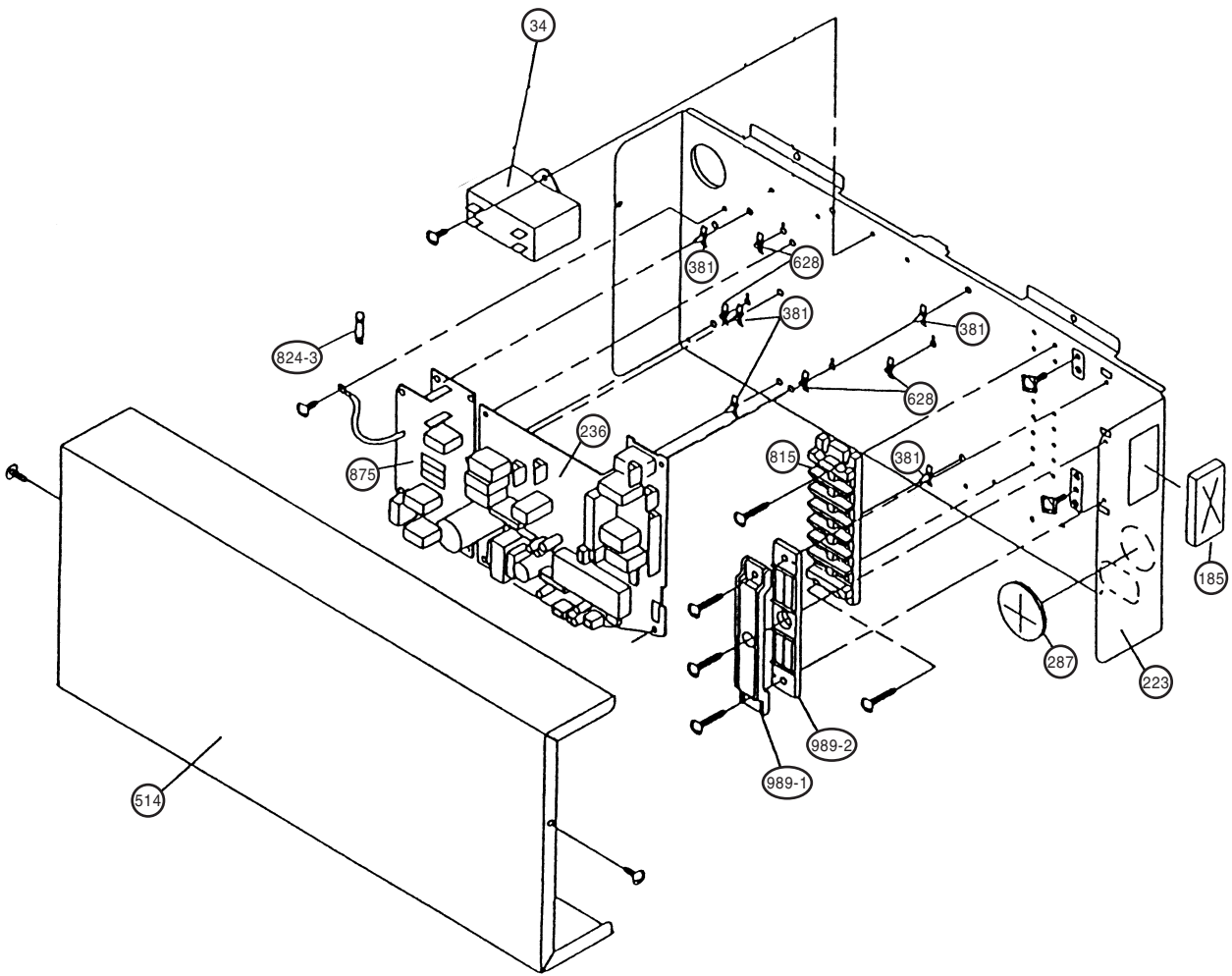

Model : CG-E

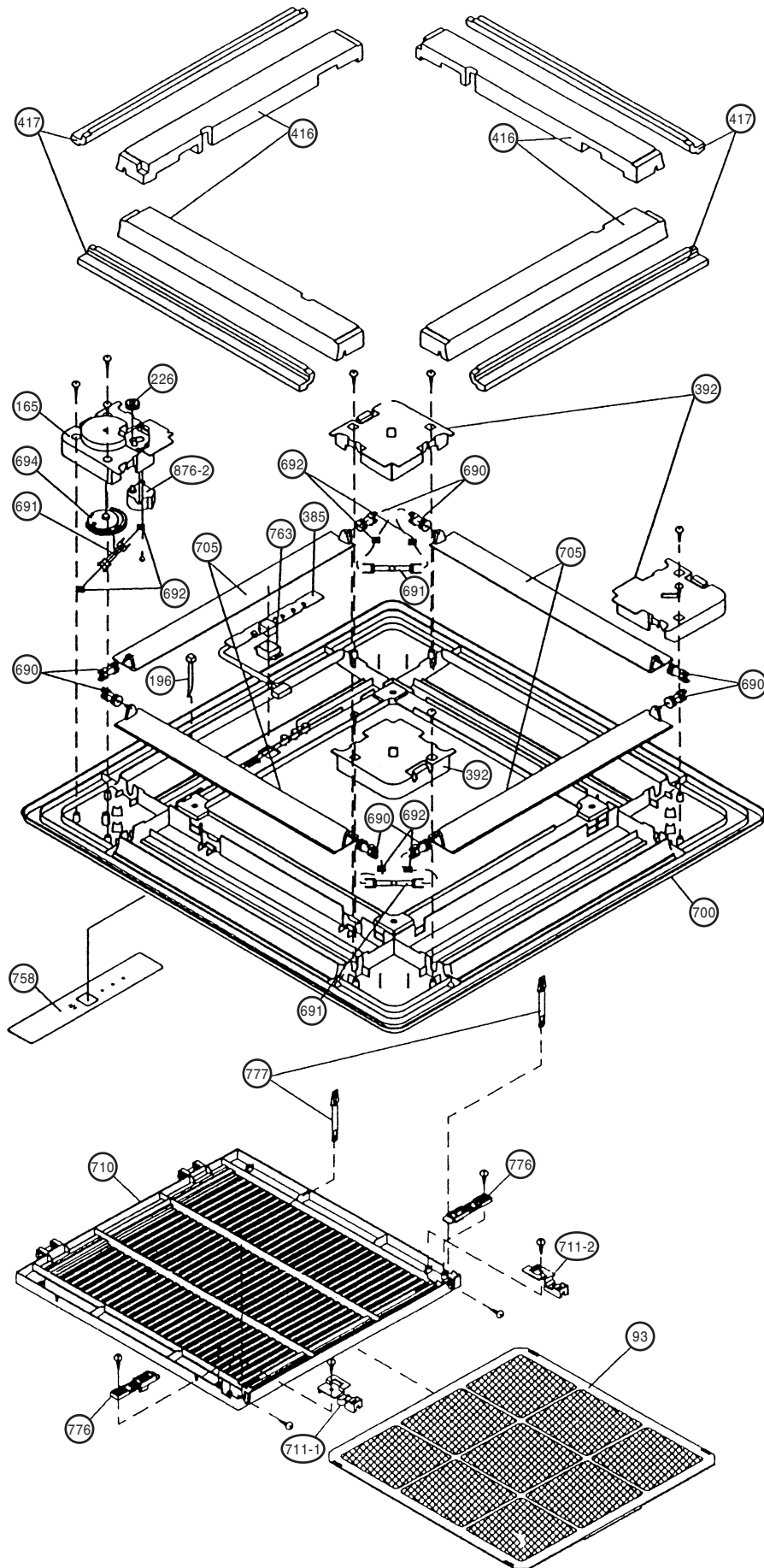

Model : RO-12HB

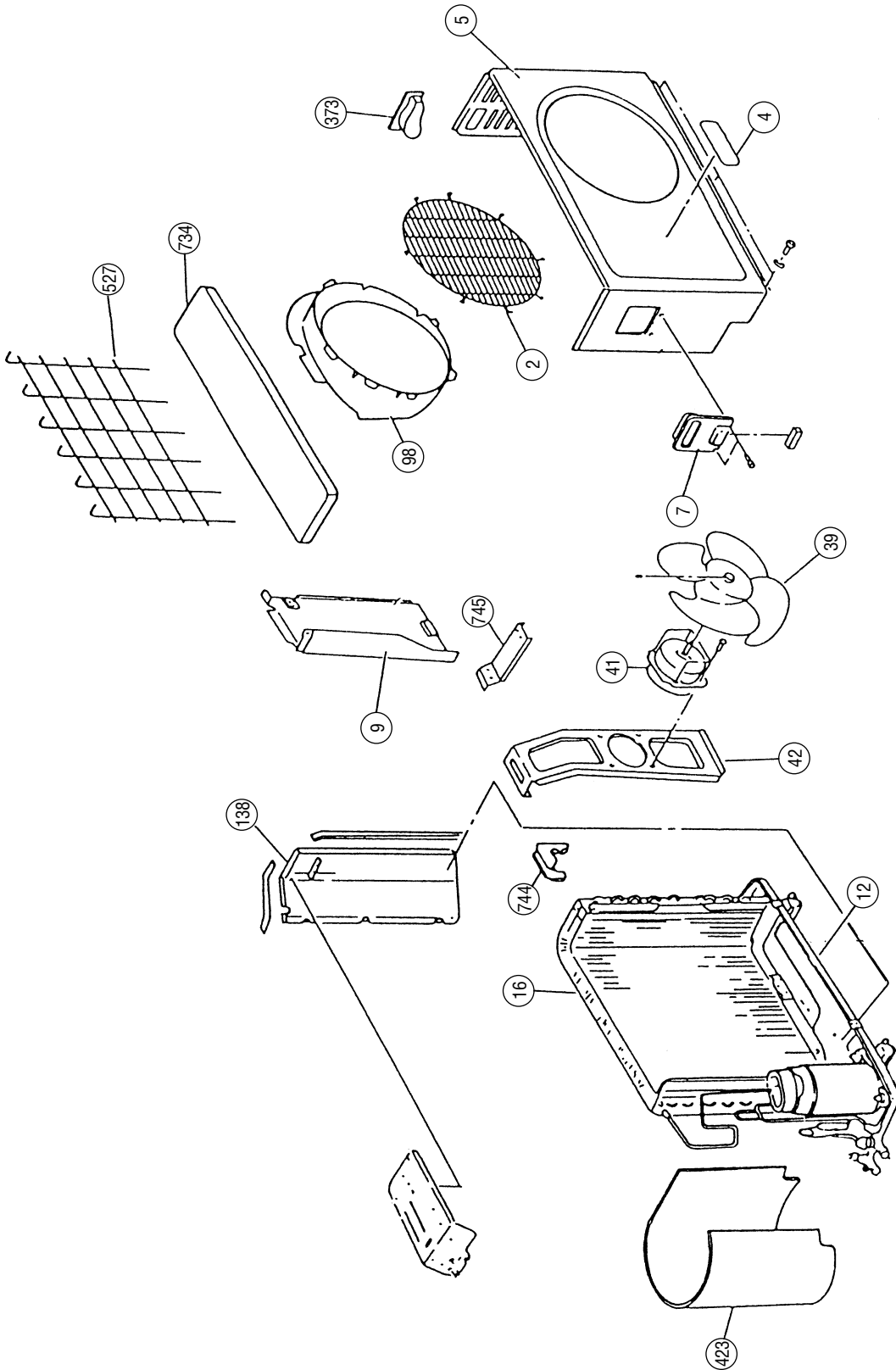

Model : RO-12HB

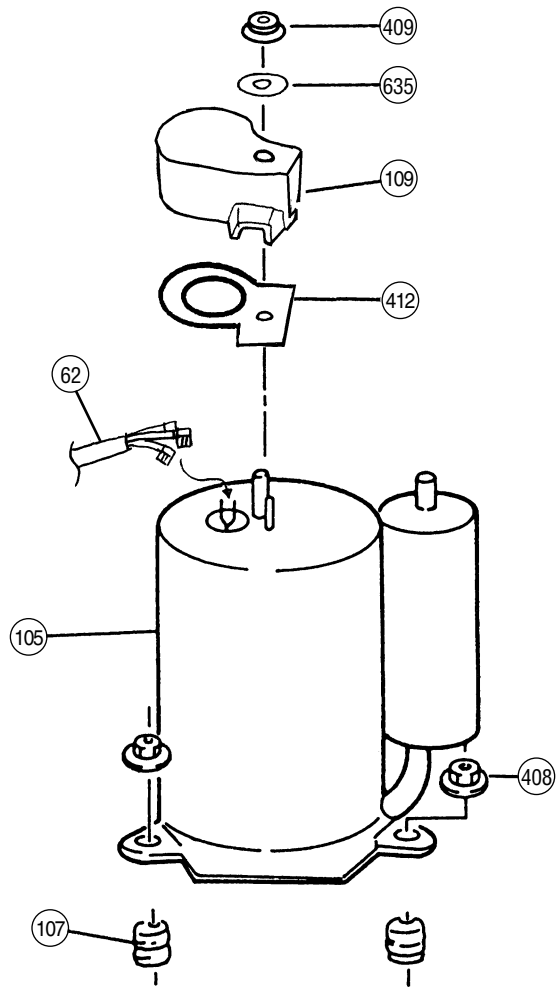

Model : RO-12HB

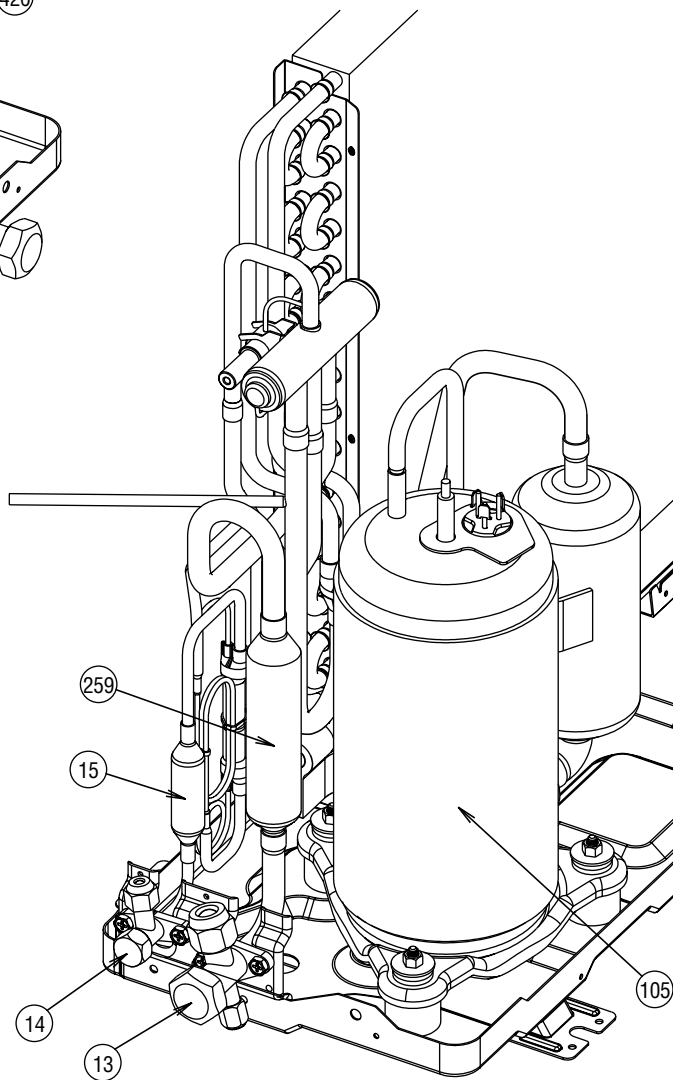
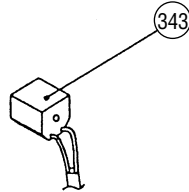
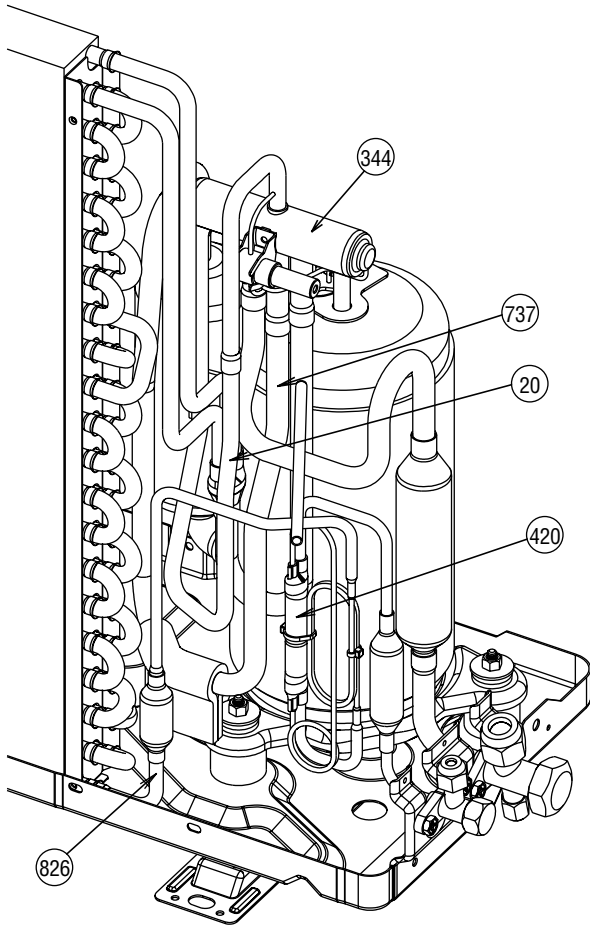

Model : RO-12HB

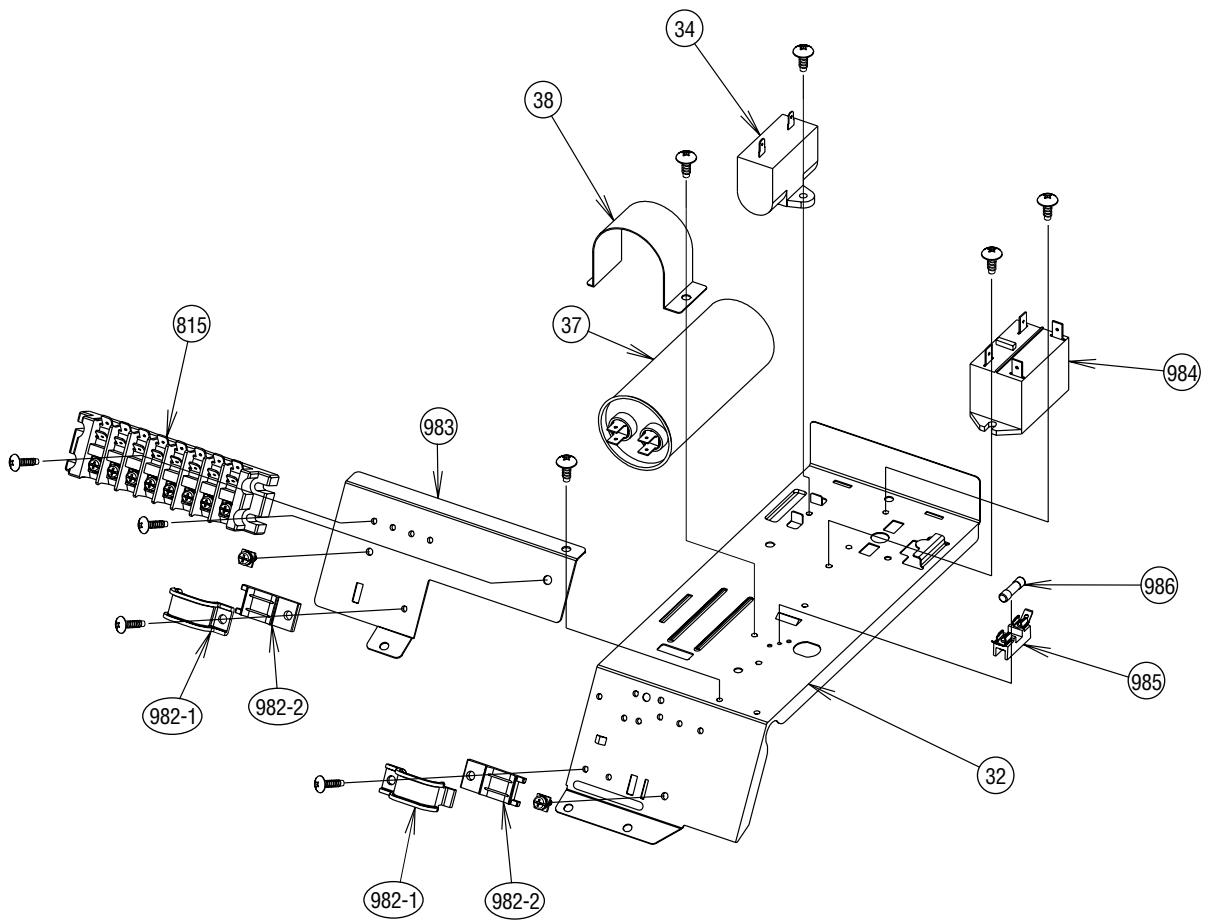

P A R T S L I S T

When you order parts, please make a photocopy of this page
and fill the number of the parts in the "Order" column.

INDOOR UNIT

Ref. No.	Description	Part No.	Ord. Q'ty	Ref. No.	Description	Part No.	Ord. Q'ty
		RCW-12HA				RCW-12HA	
34	Capacitor (Fan Motor)	9704305046		465	Cabinet-B	9359645009	
67	Rubber	9361279001		467	Drain Port	313005415658	
117-3	Special Washer M6	313306391007		468	Special Nut-A (Large)	313005446653	
127	Drain Hose	9359659013		469	Special Nut (Small)	313005446759	
138	Separate Wall-A	9359647003		470	Separate Wall-B	9359648000	
146	Evaporator Assy-In	9363837001		474	Turbo Fan	9359658009	
147	Inlet Pipe (Eva.) Assy	9363517002		475	Turbo Fan Rubber	9366013006	
160	Drain Pan	9359651000		476-1	Special Nut M8	313005360755	
164	Fan Motor Assy-In	9601040064		476-2	Special Washer	301801185049	
184-1	Thermo. Spring-A	313728262708		476-3	Special Washer	9359954002	
185	Rubber Bushing	313005066051		478	Sensor M. Bracket	9359654001	
187	Clamp No. 1219	313361271706		479	Float Switch	313005416154	
196	Clamp SKB-150	313035356905		482	Pump Unit	9359974000	
223	Control Box	9359661016		484	Hanger Metal	9359644002	
232	Outlet Pipe (Eva.) Assy	9363518009		488	Drain Pan Plug	9359653004	
234	Thermistor Assy-Room	9703299032		495	Clamp No. 2U46	9352715006	
235	Thermistor Assy-Pipe	9703297014		514	Control Box Cover	9359662006	
236	Controller PCB Assy	9704557568		628	Locking Spacer-B	313005446558	
240	Remote Control Unit	9371190037		652-1	Thermo. Holder Pipe	313806262805	
244	Pipe Cover	9359646006		743	Remote Control Holder Case	9305642014	
287	Cap (Power)	9352173011		797	Separate Wall-C	9359649007	
301	Clamp NK-2N	313985355201		798	Pump Hook Bracket	9359650003	
313	Hooking Wire	9359983002		815	Terminal-7P	9358660102	
338	Motor Fixture	9359656005		824-3	Fuse	0600222512	
381	Locking Spacer	313209391506		834	Wire Cover	9359878001	
395	Supporter (Eva.)	9359669005		835	Cushion-A (For Comp.)	9352211003	
399	Air Duct	9359660002		836	Cushion-B (For Comp.)	9356084016	
411	Supporter-A	9359655008		875	Filter PCB Assy	9704561169	
430	Clamp NK-7N	313095365602		964	Flare Nut-A	313996239804	
457	Drain Pan Support	9359652007		965	Flare Nut-B	9351062019	
462	Top Cover Plate	9359642015		989-1	Cord Clamp-A	9359822011	
464	Cabinet-A	9359643005		989-2	Cord Clamp-B	9359823018	

When you order parts, please make a photocopy of this page and fill the number of the parts in the "Order" column.

OUTDOOR UNIT





Ref. No.	Description	Part No.	Ord. Q'ty	Ref. No.	Description	Part No.	Ord. Q'ty
		RO-12HB				RO-12HB	
2	Fan Cover	9304109006		259	Muffler	313505083900	
4	Emblem-Rear	9361328006		343	Solenoid	9704061034	
5	Cabinet, Painted	9302936017		344	4-Way Valve	9307556012	
7	Connector Cover	9357970004		373	Grip	313166178700	
9	Cabinet, Rear Painted	9303744017		408	Special Nut M8	9307615016	
12	Base Assy, Painted	9354490070		409	Flange Nut	9358079003	
13	3-Way Valve	9364616001		412	Terminal Packing	9358077009	
14	2-Way Valve	9364615004		420	Capillary Assy	9372197202	
15	Dryer Assy	313523082505		423	Noise Insulation-F (For Comp.)	9350944019	
16	Condenser Assy	9365760002		527	Protection Net	9355444002	
20	Exit Pipe-A	9372179093		635	Rubber Washer	9358078006	
32	Control Box Metal-A	9355843003		734	Cabinet Top Plate	9302937014	
34	Capacitor (Fan Motor)	9704305039		737	Suction Pipe-A	9372176146	
37	Rubber Capacitor	9704436122		744	Clamp (Condenser)	313166274106	
38	Capacitor Clamp Metal	313468061808		745	Motor Support	313166036308	
39	Propeller Fan Assy	9351589011		815	Terminal-8P	9900203047	
41	Fan Motor Assy-Out	9601113096		826	Condensing Pipe-B Assy	9353015006	
42	Bracket (Motor)	313166243804		982-1	Cord Clamp	9356857009	
62	Wire Assy (Shield)-A	9370945089		982-2	Cord Clamp-B	9356858006	
98	Fan Ring	313166296109		983	Terminal Holder	9373090014	
105	Compressor Assy	9360106001		984	Relay	9900074012	
107	Rubber Seat-A	9358080009		985	Fuse Holder	0500063024	
109	Terminal Cover	9358076002		986	Fuse	0600222529	
138	Separate Wall Assy	9303729014					

GRILLE ASSY (CG-E)

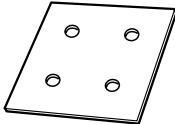
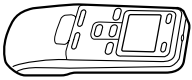
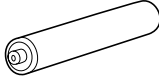
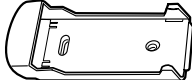

Ref. No.	Description	Part No.	Ord. Q'ty	Ref. No.	Description	Part No.	Ord. Q'ty
93	Filter	9359632009		694	Cam Gear	9359628002	
165	Motor Cover	9359623014		700	Panel	9359619017	
196	Clamp SKB-150	313035356905		705	Louver	9359624011	
226	Motor Gear	9359629009		710	Intake Grille	9360543011	
385	Indicator PCB Assy	9702224011		711-1	Filter Clamp-A	9359634003	
392	Cover-A	9359622017		711-2	Filter Clamp-B	9359635000	
416	Insulation (Panel)-A	9359620006		758	Decoration Plate-A	9360862013	
417	Insulation (Panel)-B	9359621003		763	Receiver Cover	9359630005	
690	Joint-A	9359626008		776	Grille Stopper	9359633013	
691	Joint-B	9359627005		777	Grille Hook	9359761006	
692	Joint Shaft	9359625001		876-2	Step Motor-A	9360307019	

STANDARD ACCESSORIES

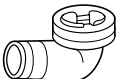

INDOOR UNIT ACCESSORIES

Name and Shape	Application	Part No.
Coupler heat insulation 	For indoor side pipe joint	9350716029
		9352766015
Special nut A (large flange) 	For installing indoor unit	313005446653
Special nut B (small flange) 	For installing indoor unit	313005446759
Template 	For ceiling hole cutting	9360256003
Remote control unit 	Use for air conditioner operation	9371190037
Battery (penlight) 	For remote control unit	0600185534
Remote control unit holder 	For mounting the remote control unit	9305642014
Tapping screw (ϕ 3 x 12) 	For remote control unit holder installation	301141533125

OUTDOOR UNIT ACCESSORIES

Name and Shape	Application	Part No.
Hexagon wrench 	For opening the refrigerant valve on the outdoor unit	301980005800
Drain Pipe 	For outdoor unit drain piping work [Heat & Cool (Reverse cycle) model only]	9303029015
Drain Cap 		313166024302

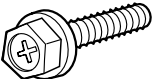
GRILLE ASSY ACCESSORIES

Name and Shape	Application	Part No.
Bolt 	For opening the refrigerant valve on the outdoor unit	0700139116
Washer 	For mounting grille	301801155020
Blower cover insulation 	For discharged air	9360047007



MANUFACTURER :

Fuji Denki Sosetsu Co., Ltd.

Tokyo, Japan