



**SPLIT TYPE  
AIR CONDITIONER**

**CASSETTE type (50Hz)**

**SERVICE  
MANUAL**

<b>Models</b>	<b>Indoor unit</b>	<b>Outdoor unit</b>
	RC-36HB	RO-36HC
	RC-45HB	RO-45HB

**CONTENTS**

SPECIFICATIONS .....	1
OUTLINE AND DIMENSIONS .....	2
CIRCUIT DIAGRAM .....	3
REFRIGERANT SYSTEM DIAGRAM .....	4
INDOOR PRINTED CIRCUIT BOARD CIRCUIT DIAGRAM .....	5
OUTDOOR PRINTED CIRCUIT BOARD CIRCUIT DIAGRAM .....	6
DISASSEMBLY ILLUSTRATION .....	7
PARTS LIST .....	14

# SPECIFICATIONS

TYPE		COOLING & HEATING	
MODEL	IN	RC-36HB	RC-45HB
	OUT	RO-36HC	RO-45HB
COOLING CAPACITY	(kW)	10.3 - 10.5	12.4 - 12.7
HEATING CAPACITY	(kW)	10.5 - 10.7	13.4 - 13.7

## ELECTRICAL DATA

POWER SOURCE	(V)	380 - 415	
	( $\phi$ /Hz)	3 $\phi$ /50	
RUNNING CURRENT (A)	COOL	7.0 - 7.0	8.1 - 8.3
	HEAT	6.2 - 6.3	8.4 - 8.4
INPUT WATTS (kW)	COOL	4.00 - 4.10	4.35 - 4.45
	HEAT	3.45 - 3.50	4.45 - 4.50
E.E.R. (kW/kW)	COOL	2.58 - 2.56	2.85 - 2.85
	HEAT	3.04 - 3.06	3.01 - 3.04
STARTING CURRENT (A)		50	66
MOISTURE REMOVAL ( $\ell$ /h)		5.0	6.0

## COMPRESSOR

TYPE	Hermetic type, 2 pole, Three-phase, Induction motor, Scroll	
CODE	ZR48K3-TFD-501	ZR61KC-TFD-599

FAN SPEED (r.p.m.)	INDOOR	HIGH	580	620
		MED	500	550
		LOW	420	470
	OUTDOOR	770		
AIR FLOW ( $m^3/h$ )	INDOOR	1,500	1,650	
	OUTDOOR	6,000	5,600	
DIMENSIONS H x W x D (mm)	NET	IN	296 x 830 x 830	
		GRILLE	35 x 940 x 940	
		OUT	1,152 x 940 x 370	
WEIGHTS (NET/GROSS) (kg)		IN	40 / 53	
		OUT	100 / 114	110 / 124
MAX PIPE LENGTH/HEIGHT (m)		50 / 30		
REMOTE CONTROLLER TYPE		WIRED		

## FULL CHARGE AMOUNT (R22)

Pipe Length	7.5m (25ft)	3000g (105.8oz)	3500g (123.5oz)
	10.0m (33ft)	3000g (105.8oz)	3500g (123.5oz)
	20.0m (66ft)	3000g (105.8oz)	3500g (123.5oz)
	25.0m (82ft)	3200g (112.9oz)	3700g (130.5oz)
	30.0m (98ft)	3400g (119.9oz)	3900g (137.6oz)
	40.0m (131ft)	3800g (134.0oz)	4300g (151.7oz)
	50.0m (164ft)	4200g (148.2oz)	4700g (165.8oz)
Additional Charge	40g/m (0.43oz/ft)		40g/m (0.43oz/ft)
Chargeless	20m (66ft)		20m (66ft)
MAX PIPE LENGTH	50m (164ft)		50m (164ft)
MAX ELEVATION	30m (98ft)		30m (98ft)

# OUTLINE AND DIMENSIONS

Unit : mm

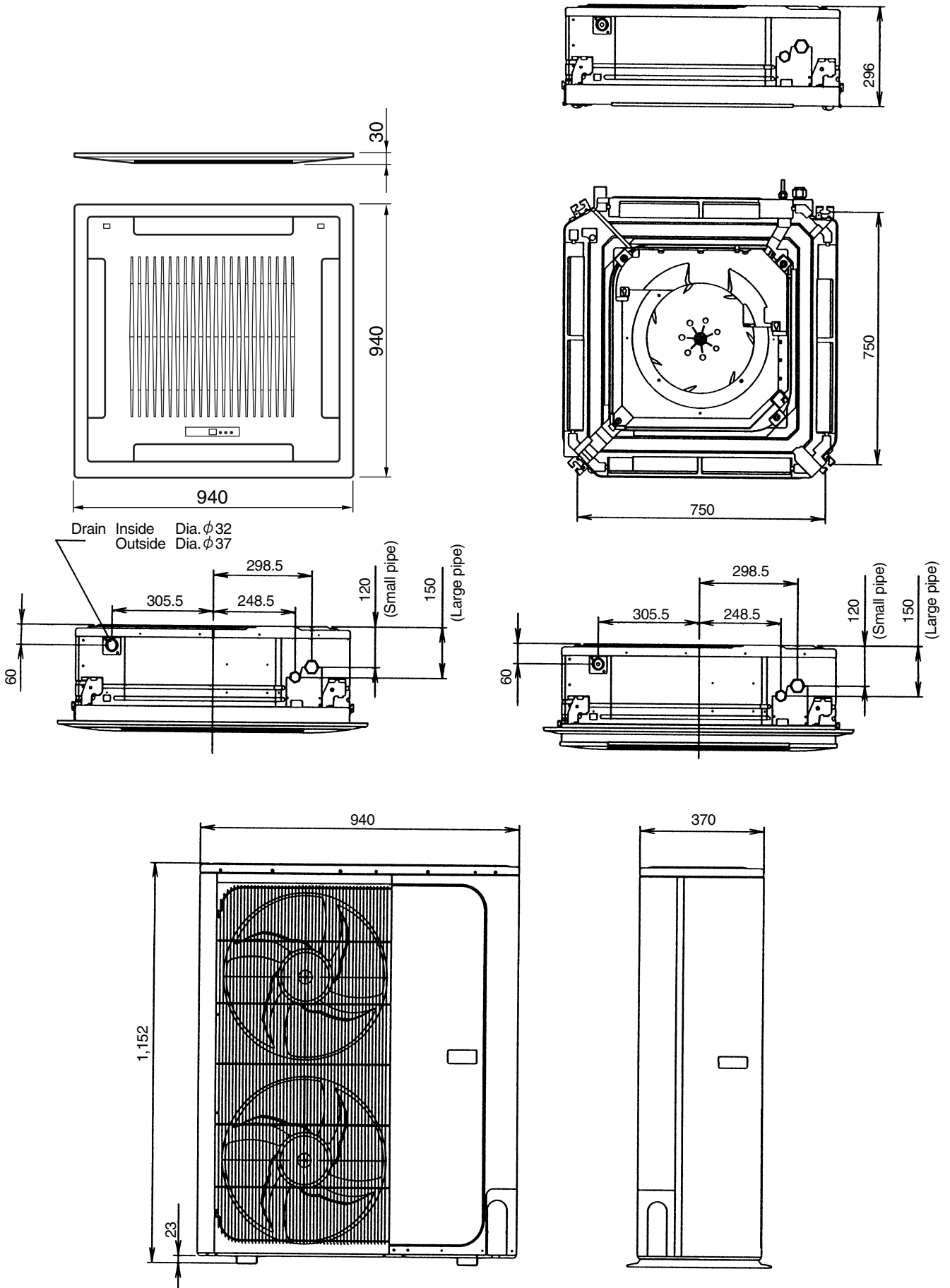

# CIRCUIT DIAGRAM

Models : RC-36HB , RC-45HB

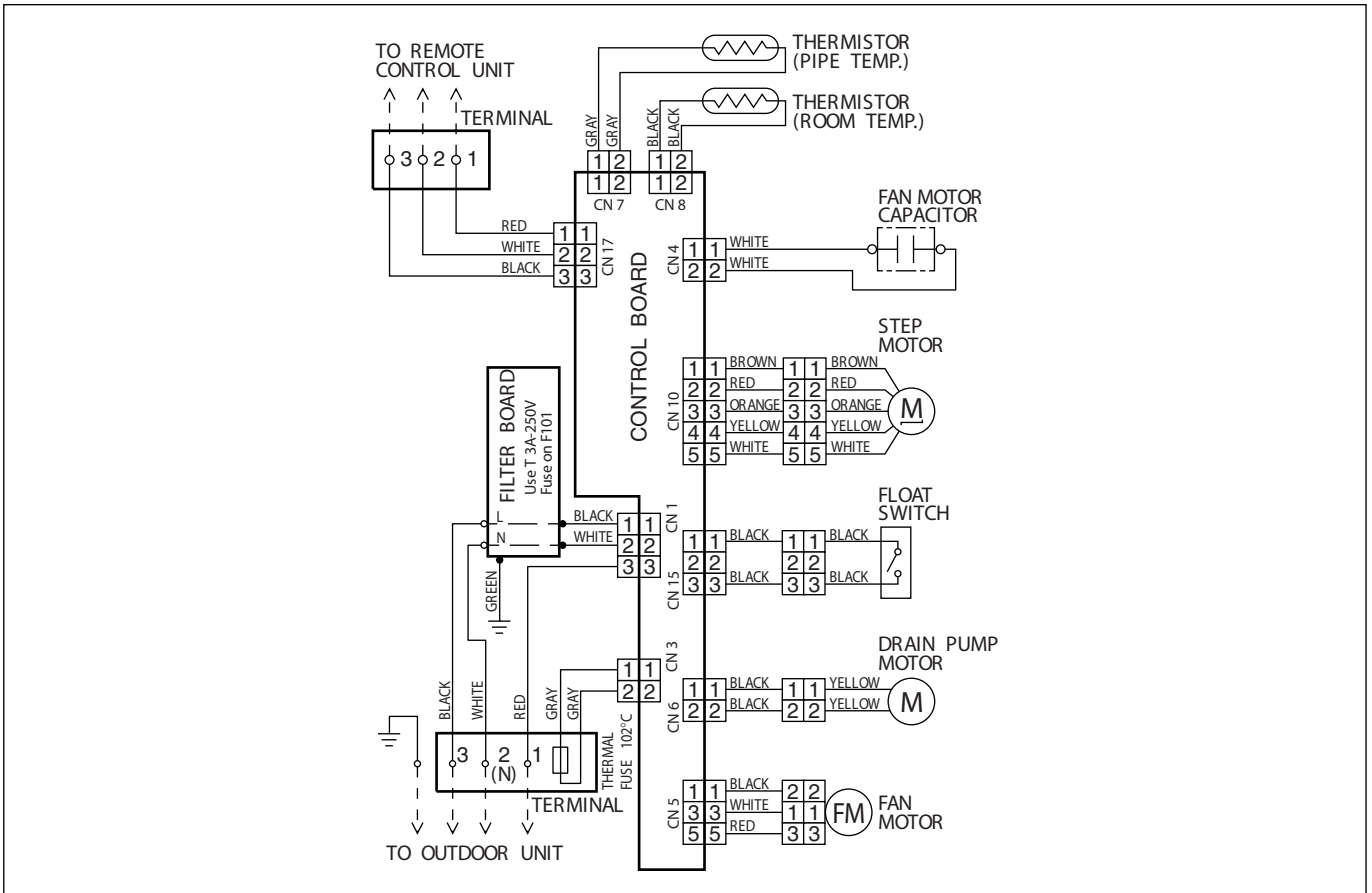

Models : RO-36HC , RO-45HB

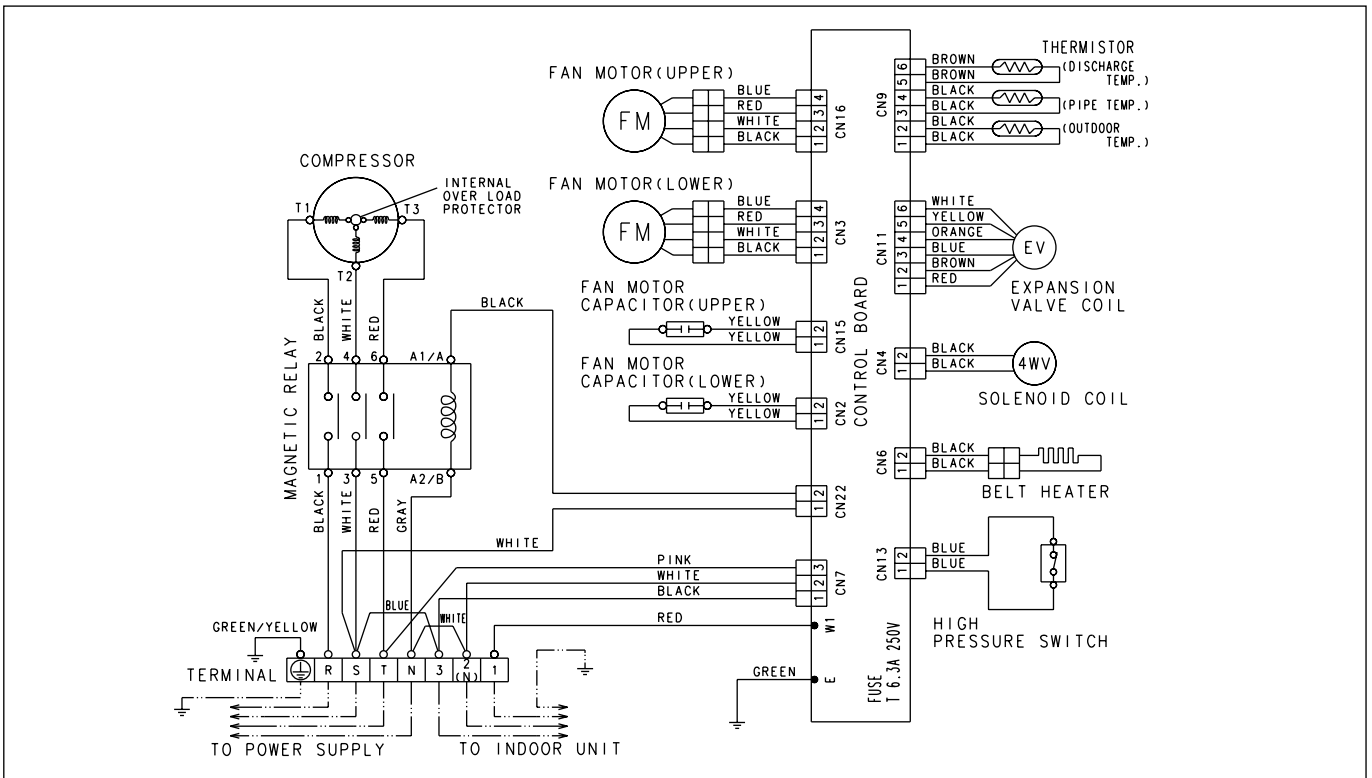

# REFRIGERANT SYSTEM DIAGRAM

Models : RC-36HB / RO-36HC  
RC-45HB / RO-45HB

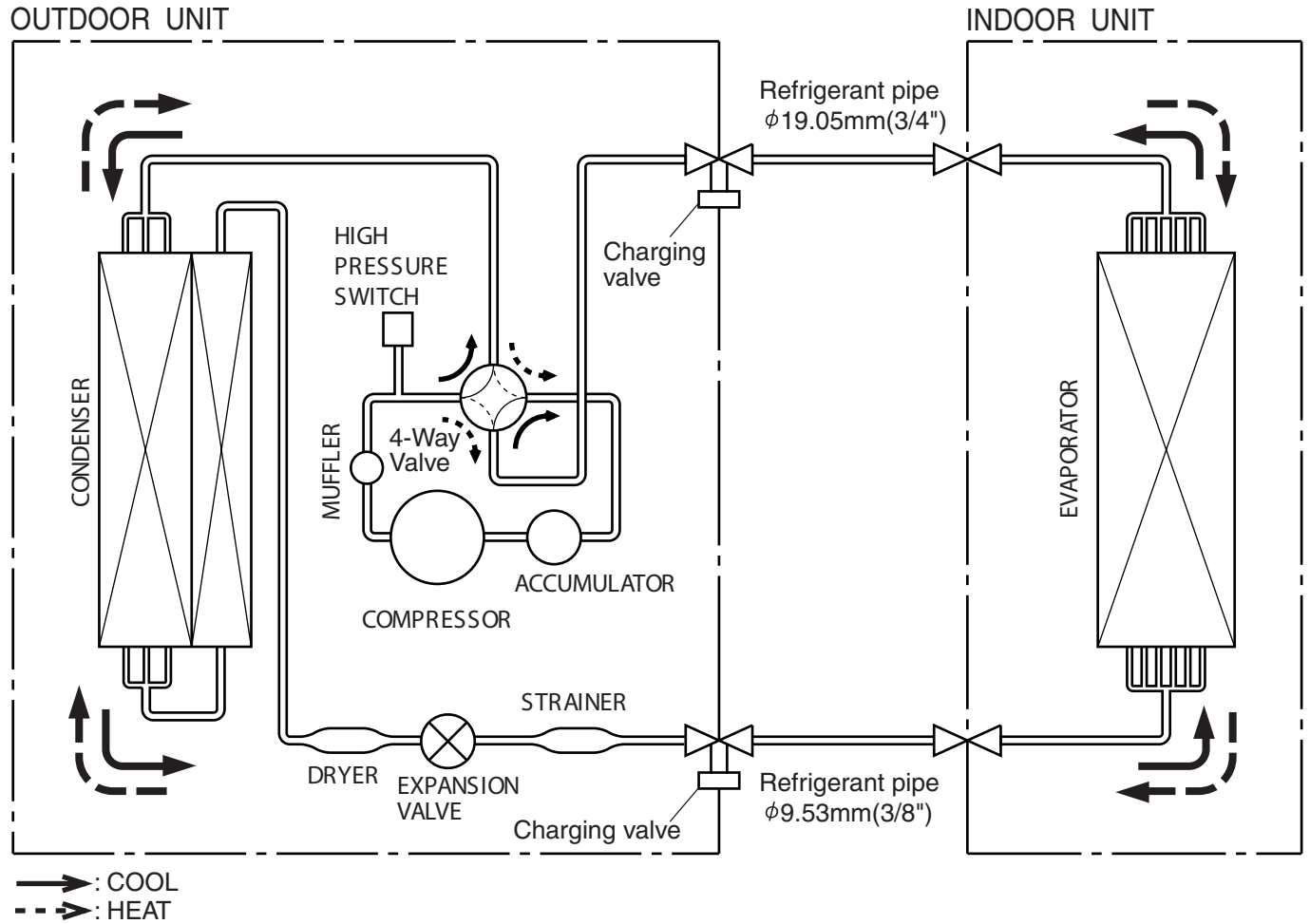

# INDOOR PRINTED CIRCUIT BOARD CIRCUIT DIAGRAM

Models : RC-36HB  
RC-45HB

CONTROLLER PCB ASSEMBLY ( MAIN PCB )  
RC-36HB : EZ-003GHSE-F  
RC-45HB : EZ-003HHSE-F

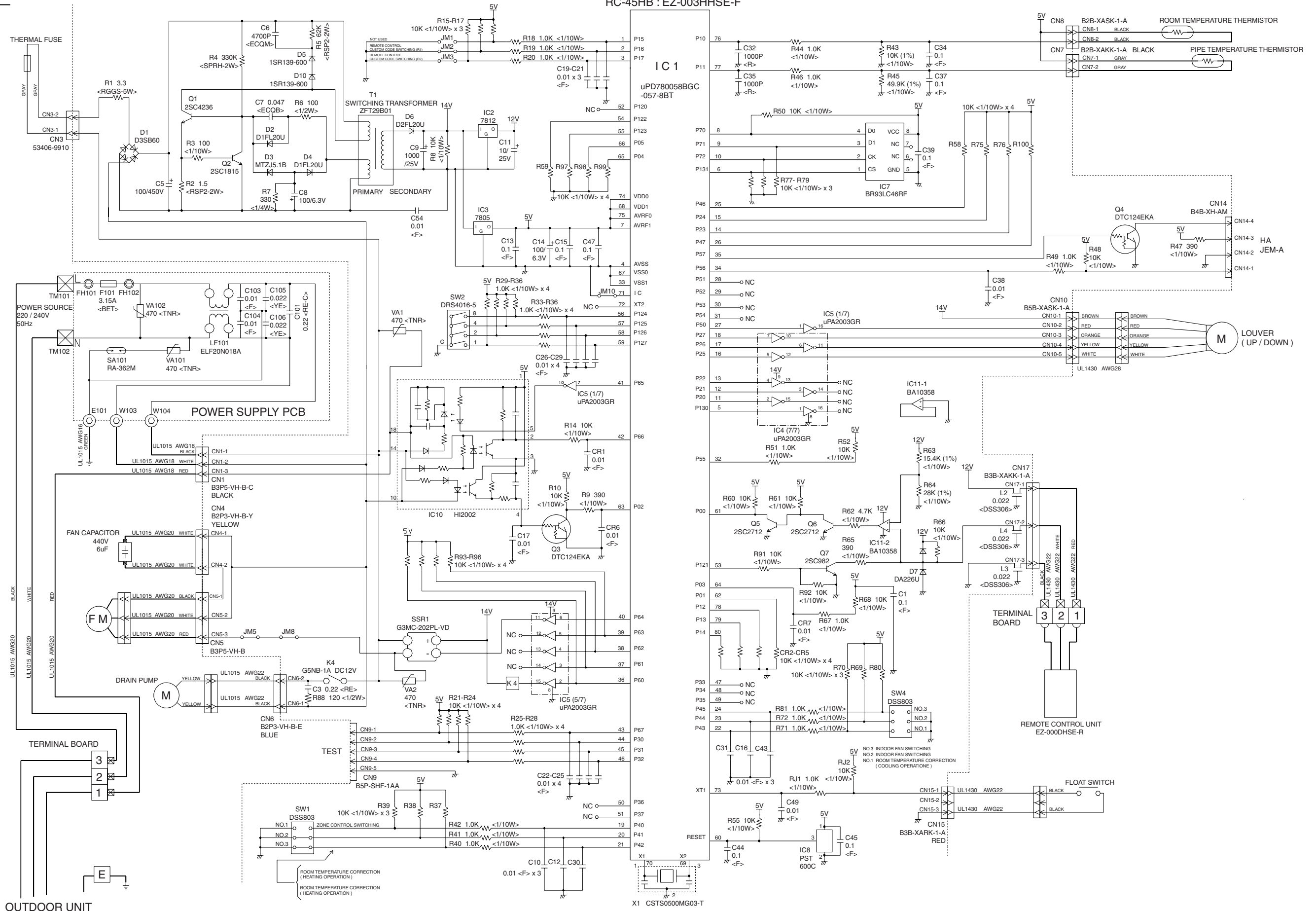

# OUTDOOR PRINTED CIRCUIT BOARD CIRCUIT DIAGRAM

Models : RC-36HB  
RC-45HB

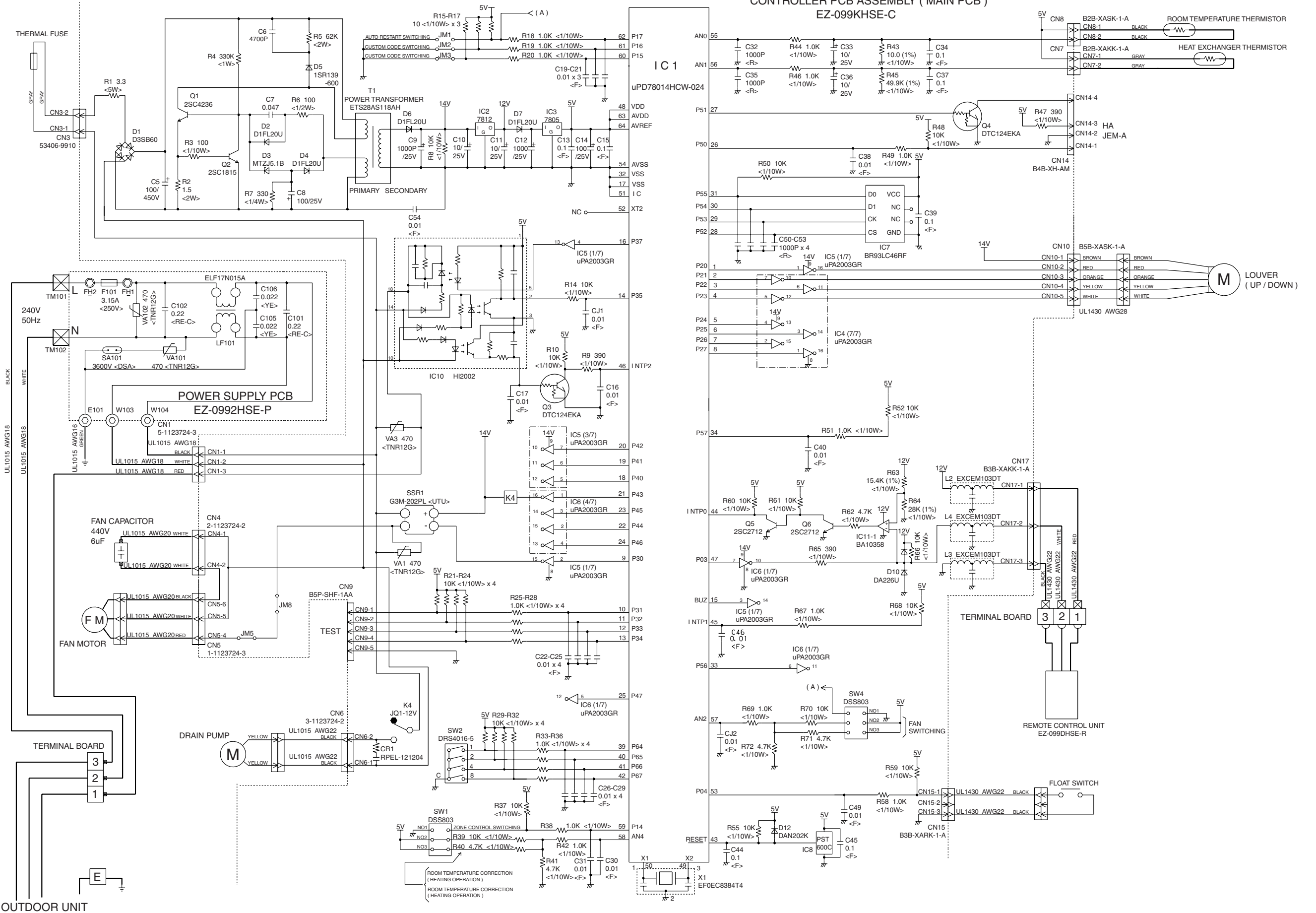





# INDOOR UNIT

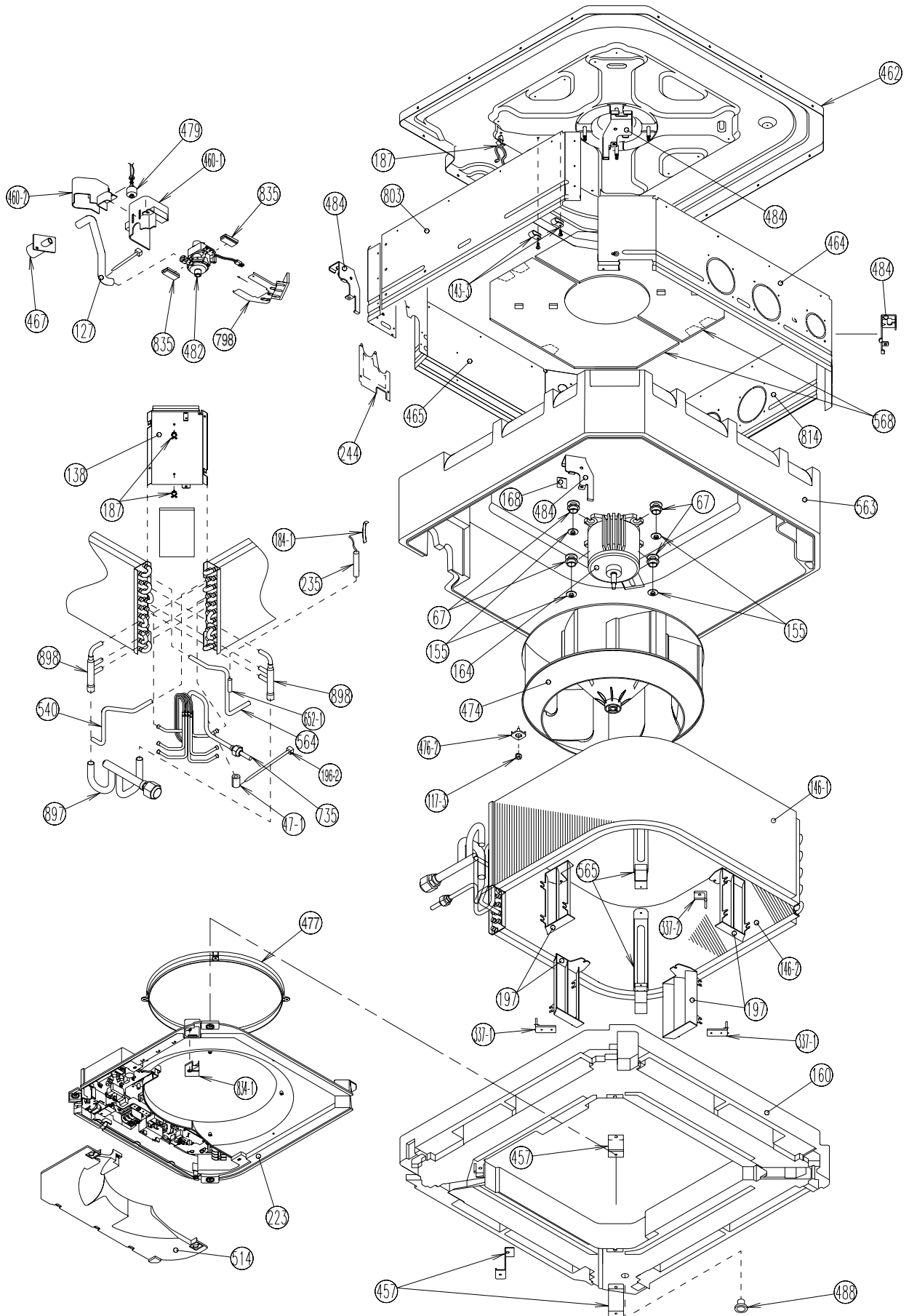



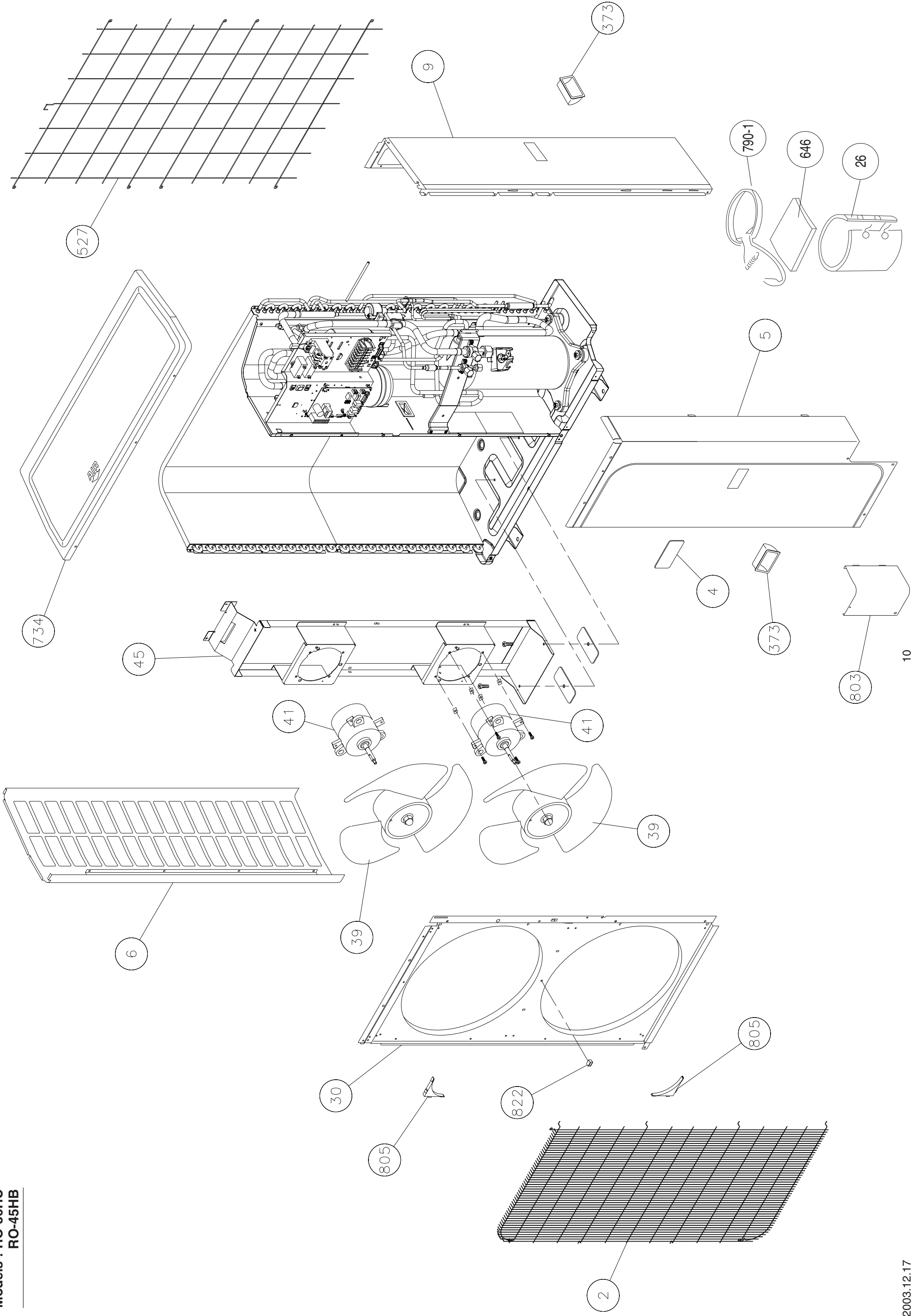

**Models : RO-36HC**

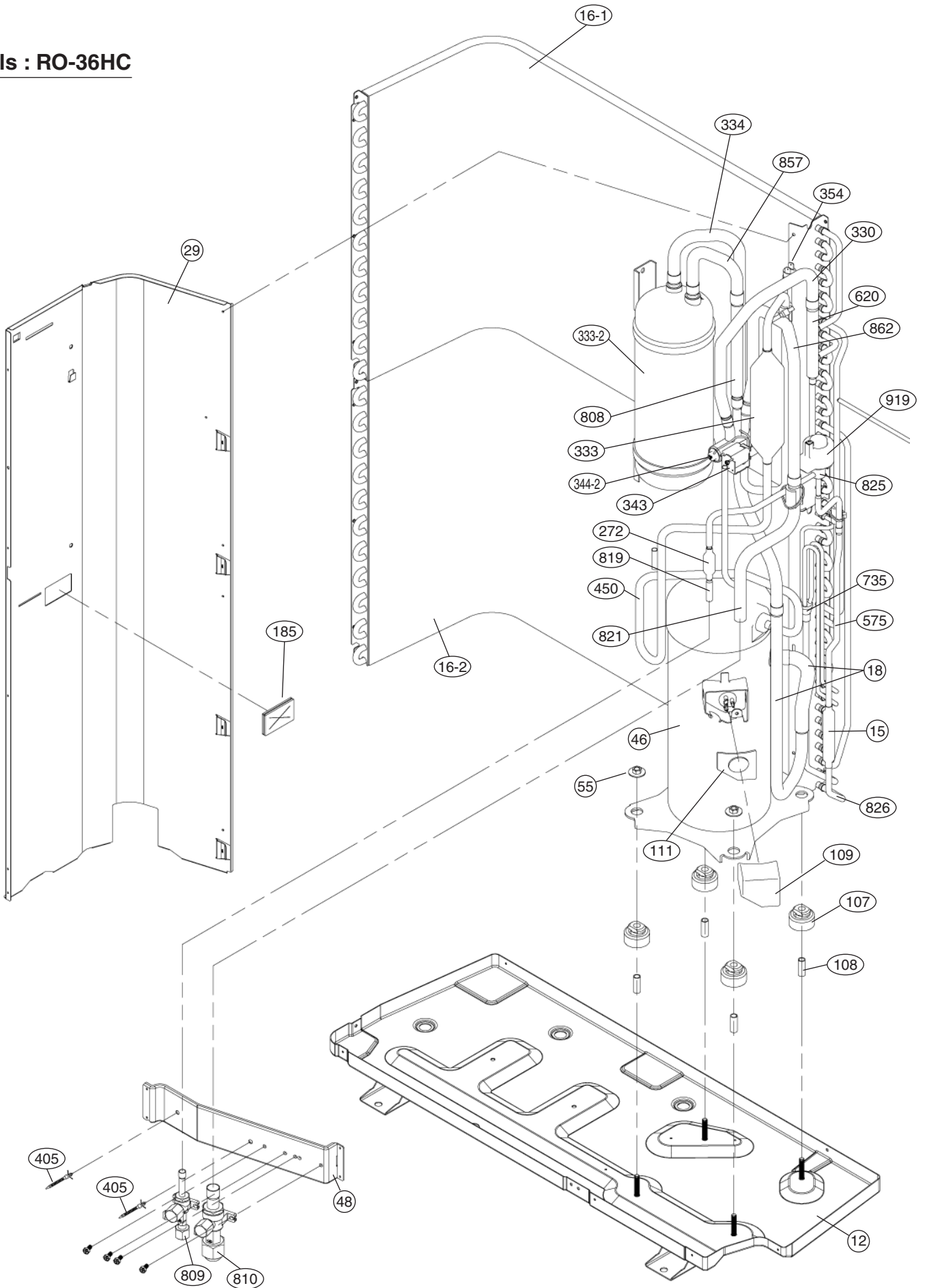

**Models : RO-45HB**

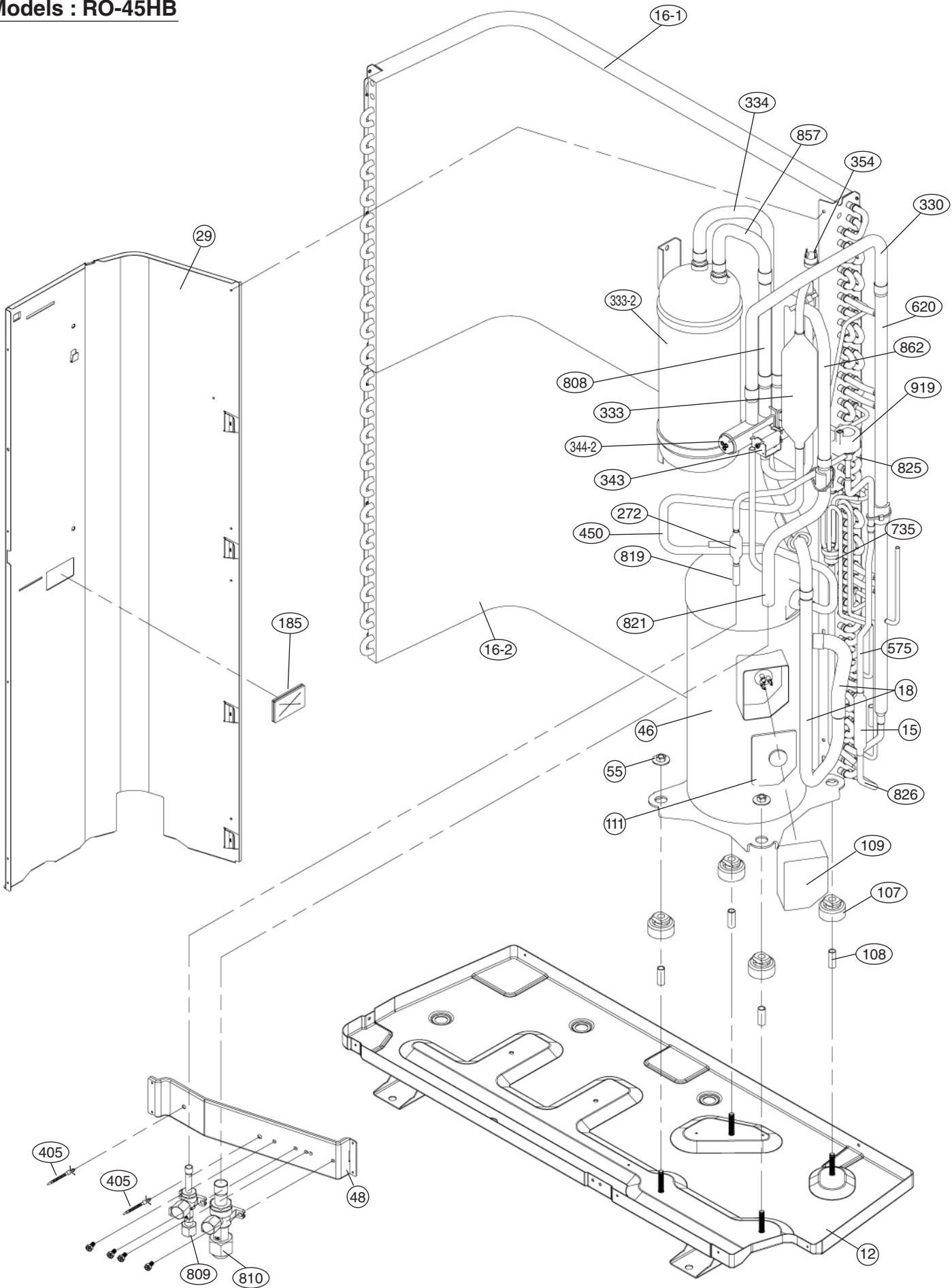

Models : RO-36HC  
RO-45HB

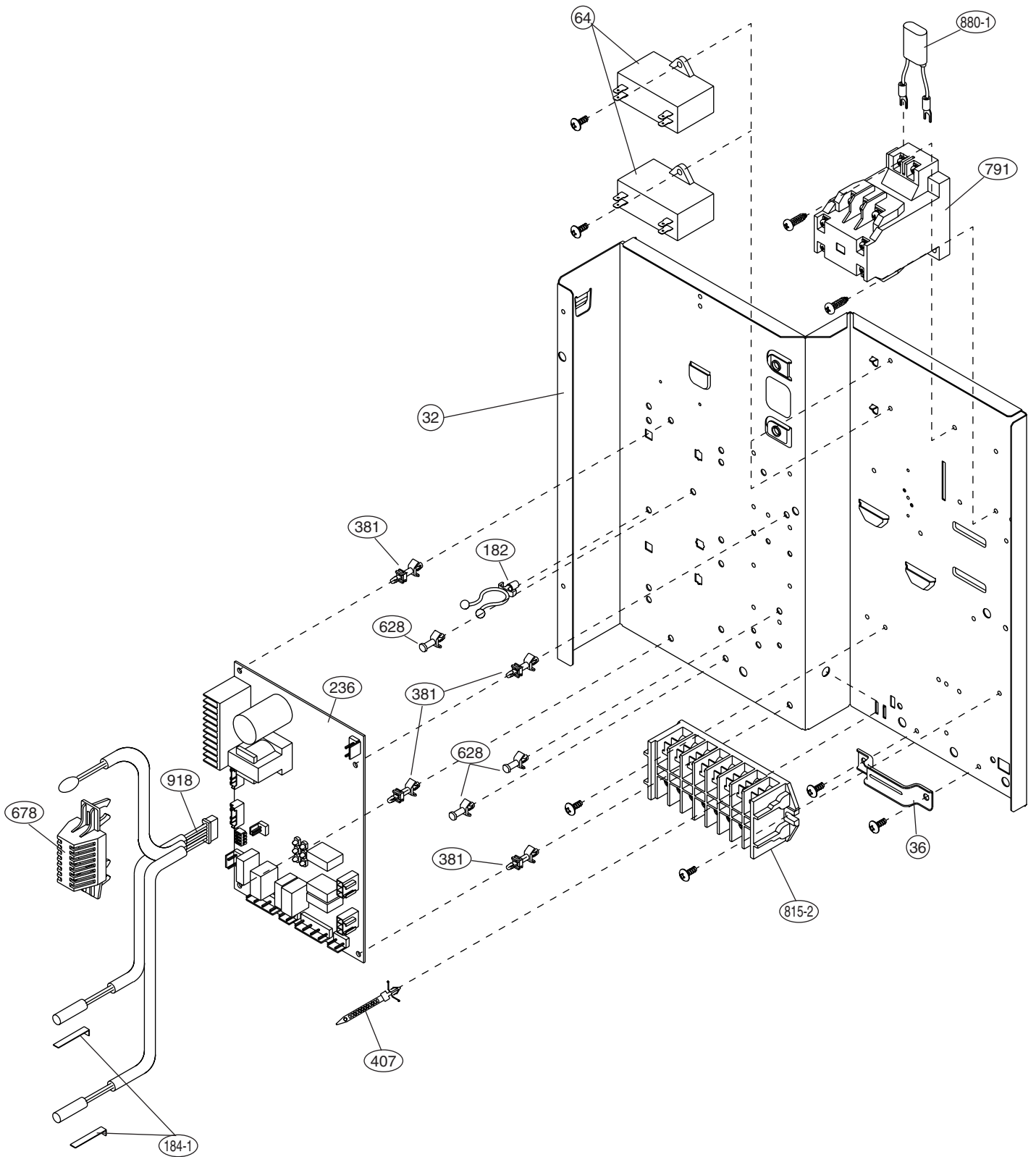

# PARTS LIST

## INDOOR UNIT

When you order parts, please make a photocopy of this page and fill the number of the parts in the "Order" column.

Ref. No.	Description	Part No.	Ord.	Ref. No.	Description	Part No.	Ord.
		RC-36HB RC-45HB	Q'ty			RC-36HB RC-45HB	Q'ty
34	Capacitor (Fan Motor)	9703306068		472-1	Grille Reinforcement•T-A	9362738002	
47-1	Rubber (Discha. Pipe)	313194159807		472-2	Grille Reinforcement•T-B	9362739009	
61	Decoration Plate	9363133004		472-3	Grille Reinforcement•T-C	9362740005	
67	Rubber (Vibration Proof)	9362783002		472-4	Grille Reinforcement•T-D	9362741002	
71	Grille Hook Holder	9362782005		472-5	Grille Reinforcement•T-E	9362742009	
93	Filter	9362766005		474	Turbo Fan Assy	9362803014	
117-3	Hex. Nut w / Spring Washer	301721180114		476-2	Special Washer	9362756006	
122	Louver Support Holder	9362799003		477	Bellmouth (B)	9362774000	
127	Drain Hose	9362784009		479	Float Switch	9703285004	
138	Separate Wall	9362737005		482	Pump Unit	9703125010	
143-1	Clamp NK-3N	313361274700		484	Hook	9362736008	
143-3	Clamp NK-9N	313209399700		487	Grille Hinge Wire	9362754002	
146-1	Evaporator-A Assy	9363149005		488	Drain Pan Plug	313005174654	
146-2	Evaporator-B Assy	9363150001		514	Control Box Cover	9362763004	
155	Special Nut M6	9307615016		522	Joint Gear	9362772006	
160	Drain Hose Assy	9362804004		540	Bypass Pipe-B	9363152005	
164	Fan Motor Assy-IN	9600878019		541	Terminal Plate	9363642001	
168	Cabinet-E	9362735001		542	Panel Base	9362759014	
184-1	Thermo. Spring-A	313728262708		543	Panel Frame Holder	9362761017	
187	Clamp No. 1219	313361271706		544	Panel Base Holder	9362760010	
195	Clamp SKB-100	313361275805		545	Panel Frame	9362758017	
196-2	Clamp SKB-150	313035356905		563	Insulation (Inner Box)	9362768009	
197	Wind Guide Board	9363117004		564	Bypass Pipe-A Assy	9363151008	
223	Control Box	9362762007		565	Evaporator Holder Assy	9362802017	
226	Motor Gear	9362764001		568	Noise Insulation	9363143003	
234	Thermistor Assy-Room	9703299025		628	Locking Spacer-B	313005446558	
235	Thermistor Assy-Pipe	9703297014		652-1	Thermistor Holder Pipe	313806262805	
236	Controller PCB Assy (for 36)	9704557421		690	Joint-A	9362773003	
236	Controller PCB Assy (for 45)	9704557438		692	Joint Shaft	9362771009	
240	Remote Control Unit	9371438016		705	Louver	9362769013	
244	Pipe Cover	9362748001		710	Intake Grille-B	9362854016	
245	Cable Clamp	313714181904		735	Distributor Assy	9363154009	
337-1	Reinforcement (Eva.)-A	9362749008		777-1	Grille Hook-A	9362779012	
337-2	Reinforcement (Eva.)-B	9362750004		777-2	Grille Hook-B	9362778015	
338	Motor Holder	9362765008		798	Pump Hook Bracket	9362753005	
381	Locking Spacer	313209391506		803	Cabinet-D	9362734004	
457	Reinforcement (Drain Pan)	9362757003		814	Cabinet-C	9362733007	
460-1	Pump Cover-A	9362775007		815-1	Terminal 3P	9306489052	
460-2	Pump Cover-B	9362776004		815-2	Terminal 3P	9703345012	
462	Top Cover Plate	9362806015		834-1	Wire Cover-A	9362789004	
464	Cabinet-A	9362800013		834-2	Wire Cover-B	9362788007	
465	Cabinet-B	9362801010		835	Cushion Rubber (Pump)	9362777001	
467	Drain Port	9362786003		847	Louver Supporter	9362770019	
468	Special Nut-A (Large)	313005446653		858	Grille Spring	9362755009	
469	Special Nut-B (Small)	313005446759		875	Filter PCB Assy	9704561091	
				876-2	Step Motor	9360307019	
				897	Coupling Pipe-A Assy	9363153002	
				898	Coupling Pipe-B Assy	9363155006	
				982-1	Cord Clamp	9356857009	

**OUTDOOR UNIT**

When you order parts, please make a photocopy of this page and fill the number of the parts in the "Order" column.







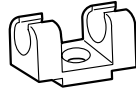

Ref. No.	Description	Part No.		Ord. Qty
		RO-36HC	RO-45HB	
2	Fan Cover	9352159015	9352159015	
4	Emblem-Rear	9361328006	9361328006	
5	Cabinet-A, Painted	9352146015	9352146015	
6	Cabinet-C, Painted	9352149016	9352149016	
9	Cabinet-B, Painted	9352147012	9352147012	
12	Base Assy, Painted	9352136016	9352136016	
15	Dryer	9368111014	9368111014	
16-1	Condenser-A Assy	9353023001	9355338011	
16-2	Condenser-B Assy	9353024008	9353363008	
18	Suction Pipe Assy	9372226025	9372226018	
21	Discharge Pipe-B	9372246023	93722466016	
26	Compressor Cover-A	9370774030	9370774030	
29	Separate Wall Assy	9355277013	9355277013	
30	Blower Cover, Painted	9352151019	9352151019	
32	Control Box Metal	9352134012	9352134012	
36	Cord Holder Metal	9356934007	9356934007	
39	Propeller Fan Assy	9366378013	9366378013	
41	Fan Motor Assy-Out	9600832028	9600832028	
45	Bracket (Motor) Assy	9368108007	9368108007	
46	Compressor-C Assy	9371396033	9371396026	
48	Bracket (Coupler) Assy	9355281010	9355281010	
55	Special Nut M8 (For Comp.)	9355091008	9355091008	
64	Capacitor (Fan Motor)	9357965024	9357965024	
107	Rubber Seat-A (For Comp.)	9364084008	9364084008	
108	Sleeve-A (For Comp.)	9364085005	9364085005	
109	Terminal Cover (For Comp.)	9364087009	9364087009	
111	Terminal Packing	9364086002	9364086002	
182	Clamp No.249	313361271505	313361271505	
184-1	Thermo. Spring-A	313728262708	313728262708	
185	Rubber Bushing	313005066051	313005066051	
236	Controller PCB Assy	9704764133	9704764096	
272	Strainer Assy	9354139008	9354139008	
330	Inlet Pipe (Cond.)-A	9372239025	9372239018	
333	Accumulator	9350363018	9350363018	
333-2	Accumulator Assy (B)	9371615011	9371615011	
334	Suction Pipe-B	9372227022	9372227015	
343	Solenoid Coil	9900165024	9900165024	
344-2	4-Way Valve	9900164010	9970035012	
354	Pressure Switch	9704045003	9704045003	
373	Grip	9352157004	9352157004	

Ref. No.	Description	Part No.		Ord. Qty
		RO-36HC	RO-45HB	
381	Locking Spacer	313209391506	313209391506	
405	Clamp No.1763	313816345304	313816345304	
407	Clamp (Cable) No.1259	313739340109	313739340109	
450	Discharge Pipe-A	9372229026	9372229019	
527	Protection Net	9352163012	9352163012	
575	Condensing Pipe-C	9372225028	9372225011	
620	Inlet Pipe (Cond.) Assy	9372224021	9372224014	
628	Locking Spacer	313005446558	313005446558	
646	Compressor Cover-B	9370774047	9370774047	
653-1	Bolt (Fan Motor Fixing)	9385089020	9385089020	
678	Bracket (Thermistor)	313557406106	313557406106	
734	Cabinet Top Plate	9352161018	9352161018	
735	Distributor Assy	9372230022	9372230015	
790-1	Belt Heater-A	9361140066	9361140042	
791	Magnetic Relay	9900078010	9900078010	
803	Cabinet-D, Painted	9352150012	9352150012	
805	Blower Cover Corner	9352160011	9352160011	
808	Inlet Pipe (Accumulator)-A	9372244029	9372244012	
809	Ball Valve-A	9371799049	9371799049	
810	Ball Valve-B	9371799056	9371799056	
813	Cabinet Hook	9352148002	9352148002	
815-2	Terminal 8P	9363276022	9363276022	
816	Wire Clamp Metal	313584219902	313584219902	
819	Valve-A Coupl. Pipe	9363457001	9363457001	
821	Joint Pipe (Valve-B)	9352284007	9352284007	
822	Fan Cover Fixture-A	9352158018	9352158018	
825	Expansion Valve	9900170011	9900170028	
826	Condensing Pipe-B	9372231012	9372231012	
857	Inlet Pipe (Accumulator)-B	9372244036	9372244036	
862	Valve-B Coupl. Pipe	9372243022	9372243015	
880-1	Network	9700987017	9700987017	
918	Thermistor Assy	9900129019	9900129019	
919	Expansion Valve Coil	9900172015	9900172015	





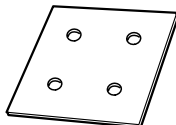

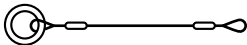



# STANDARD ACCESSORIES

## INDOOR UNIT ACCESSORIES

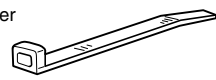
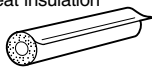
Name and Shape	Part No.
Coupler heat insulation 	9350716029 } 1 each 9352766015 }
Remote control unit cord clamp 	313714181904
Binder 	313035356905 (Large)
	313361275805 (Small)
Screw 	(A) 301141134166 For installing the mounting bracket
	(B) 301141153027 For installing the cord clamp
Special nut A (large flange) 	313005446653
Special nut B (small flange) 	313005446759
Remote control unit 	9371438016
Template 	9363173000
Blower cover insulation 	9363265002
Hook wire 	9363168006

## OUTDOOR UNIT ACCESSORIES

Name and Shape	Part No.
Power cap 	9352173011
Auxiliary pipe assembly 	9355292016
Edge cover 	9352436000
Tapping screw 	301463040100
Binder 	313035356905
Putty	303020200114
Coupler heat insulation 	313005074759
Pipe (drain) 	313728031005
Flexible tube 	313013042915
Cap (drain) 	313166024302

