

**FUJITSU**  
**ELECTRIC**

**SPLIT TYPE AIR  
CONDITIONER (50Hz)  
DUCT type**

**SERVICE  
MANUAL**

Models	Indoor unit	Outdoor unit
	<b>RD-60CC</b>	<b>ROD-60CB</b>
	<b>RD-60HC</b>	<b>ROD-60HB</b>

**C O N T E N T S**

SPECIFICATIONS .....	1
OUTLINE AND DIMENSIONS .....	2
REFRIGERANT SYSTEM DIAGRAM .....	4
CIRCUIT DIAGRAM .....	5
PCB CIRCUIT DIAGRAM .....	7
DIP SWITCH SETTING .....	10
ERROR CONTENTS .....	11
DISASSEMBLY ILLUSTRATION .....	12
PARTS LIST .....	19
STANDARD ACCESSORIES .....	22

# SPECIFICATIONS

TYPE		Cooling	Colling & Heating
INDOOR UNIT		RD-60CC	RD-60HC
OUTDOOR UNIT		ROD-60CB	ROD-60HB
COOLING CAPACITY	(kW)	16.4 - 17.0	16.4 - 17.0
HEATING CAPACITY	(kW)	-----	17.8 - 18.2

## ELECTRICAL SPECIFICATIONS

POWER SUPPLY	(V)	380 - 415	
FREQUENCY	(Hz)	50	
RUNNING CURRENT	(A)	COOLING	9.8 - 9.8
		HEATING	-----
INPUT	(kW)	COOLING	5.80 - 5.90
		HEATING	-----
EER	(kW/kW)	COOLING	2.83 - 2.88
		HEATING	-----
MOISTURE REMOVAL	(ℓ/hr)	6.5	
AIR CIRCULATION - Hi	(m <sup>3</sup> /hr)	3,600	

## COMPRESSOR

TYPE	Hermetic type, 2 poles, 3-phase, Induction motor, Scroll		
DISCRIMINATION	ZR72KC-TFD		
REFRIGERANT	R-22	(g)	3,800      4,800

## FAN MOTOR

POWER SUPPLY	(V)	240	
INDOOR UNIT		DISCRIMINATION	MFA-60NTFS
		HI-SPEED (r.p.m.)	1,300
		MED-SPEED (r.p.m.)	1,135
		LO-SPEED (r.p.m.)	960
OUTDOOR UNIT		DISCRIMINATION	MFB-362FT
		HI-SPEED (r.p.m.)	800

## DIMENSIONS

INDOOR UNIT	H x W x D	(mm)	400 x 1,050 x 500
OUTDOOR UNIT	H x W x D	(mm)	1,355 x 940 x 370

INDOOR UNIT	NET / GROSS	(kg)	50 / 55
OUTDOOR UNIT	NET / GROSS	(kg)	121 / 136      129 / 144

## REFRIGERANT CHARGE (R-22)

Full Charge Amount	PIPE LENGTH	7.5 m	3,800 g	4,800 g
		10.0m	3,900 g	4,800 g
		20.0 m	4,300 g	4,800 g
		30.0 m	4,700 g	5,400 g
		40.0 m	5,100 g	6,000 g
		50.0 m	5,500 g	6,600 g
Additional Charge			40 g / m	60 g / m
Chargeless			7.5 m	20 m
MAX PIPE LENGTH			50 m	50 m
MAX ELEVATION			30 m	30 m

# OUTLINE AND DIMENSIONS

(Unit : mm)

## INDOOR UNIT

Models : RD-60CC  
RD-60HC

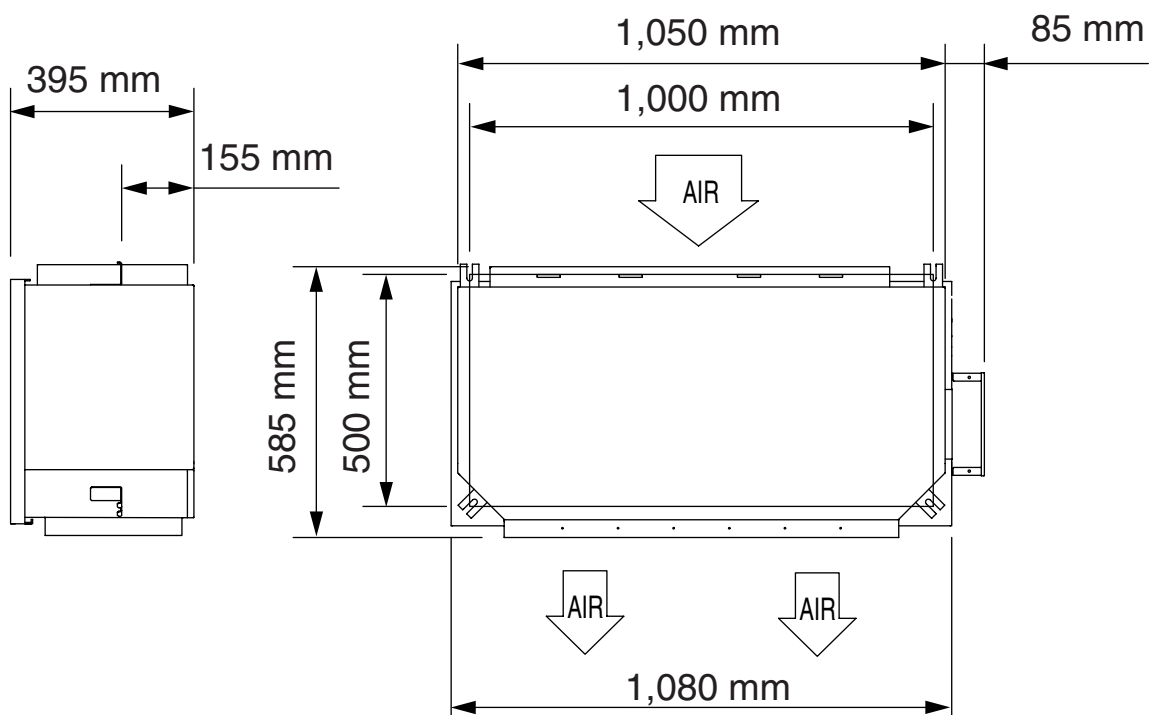

**OUTDOOR UNIT (Unit : mm)**

**Models : ROD-60CB  
ROD-60HB**

---

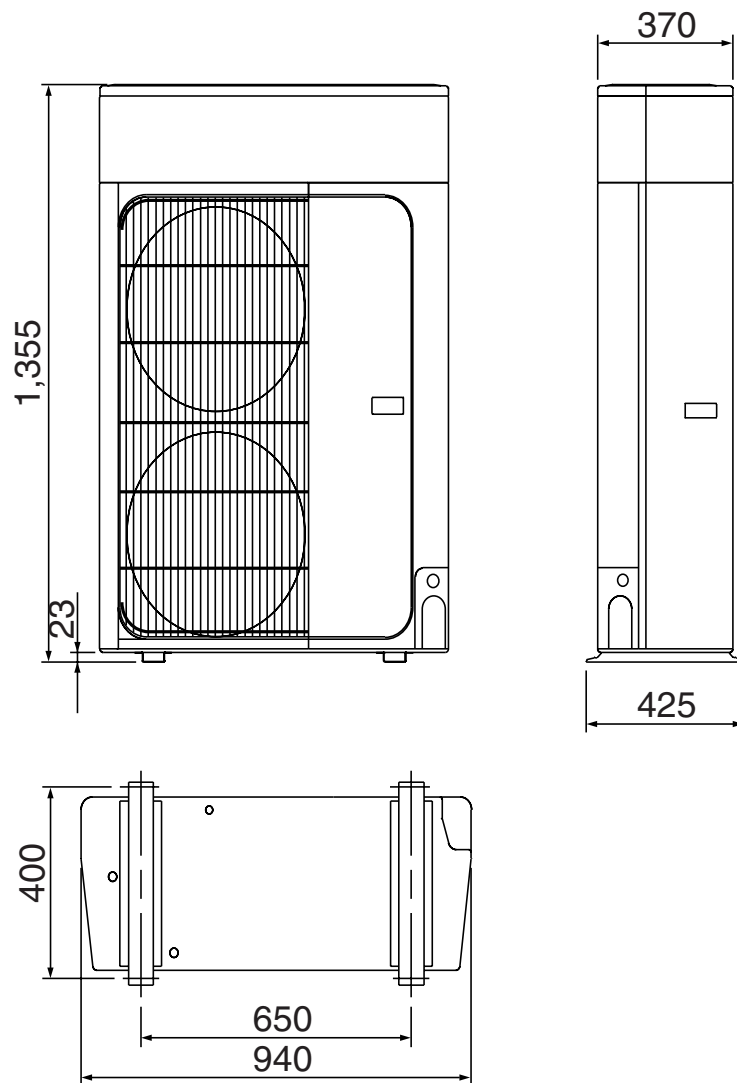

# REFRIGERANT SYSTEM DIAGRAM

Model : RD-60CC / ROD-60CB

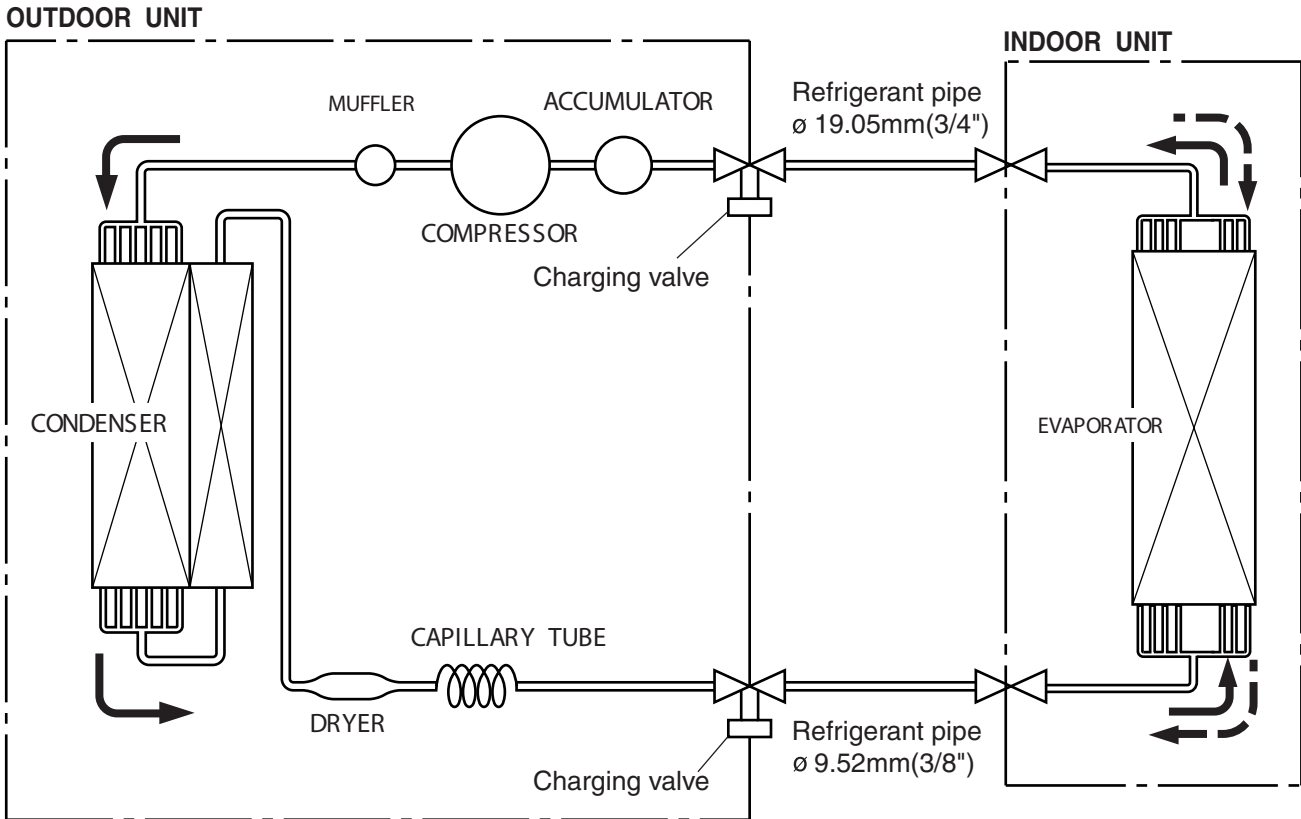

Model : RD-60HC / ROD-60HB

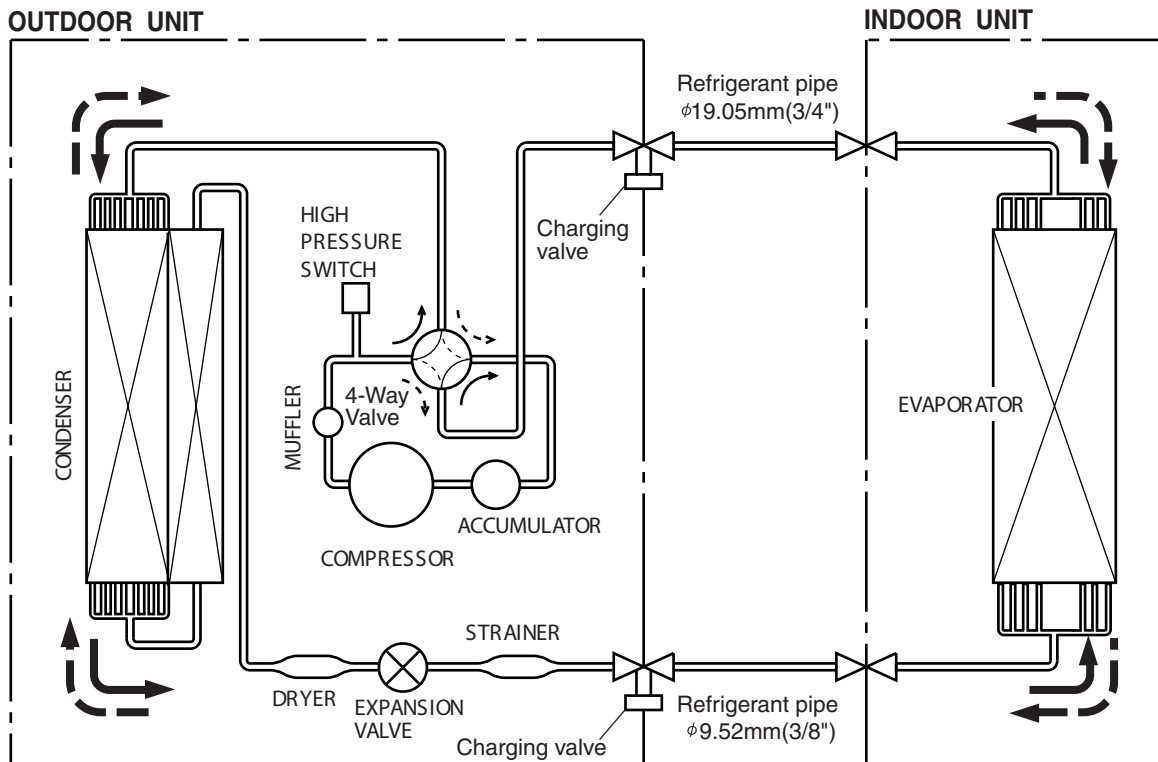

—→ : COOL  
 - - -→ : HEAT

# CIRCUIT DIAGRAM

Model : RD-60CC

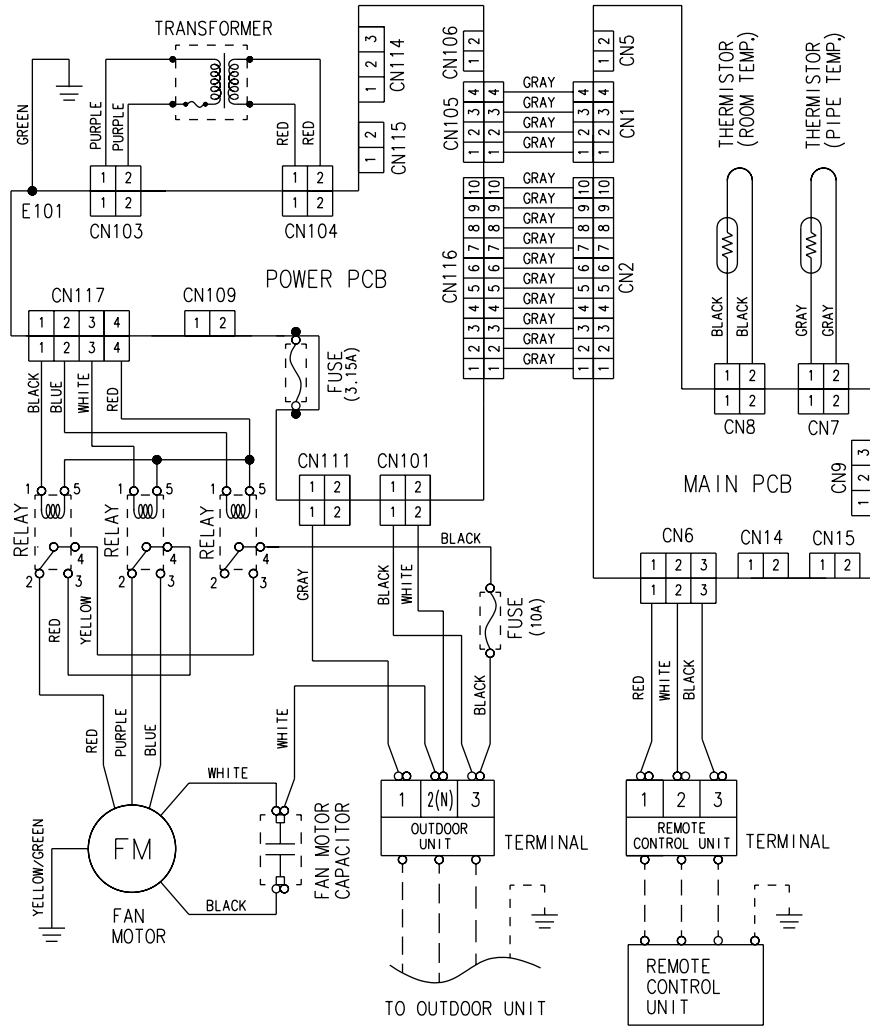

Model : ROD-60CB

## WIRING DIAGRAM

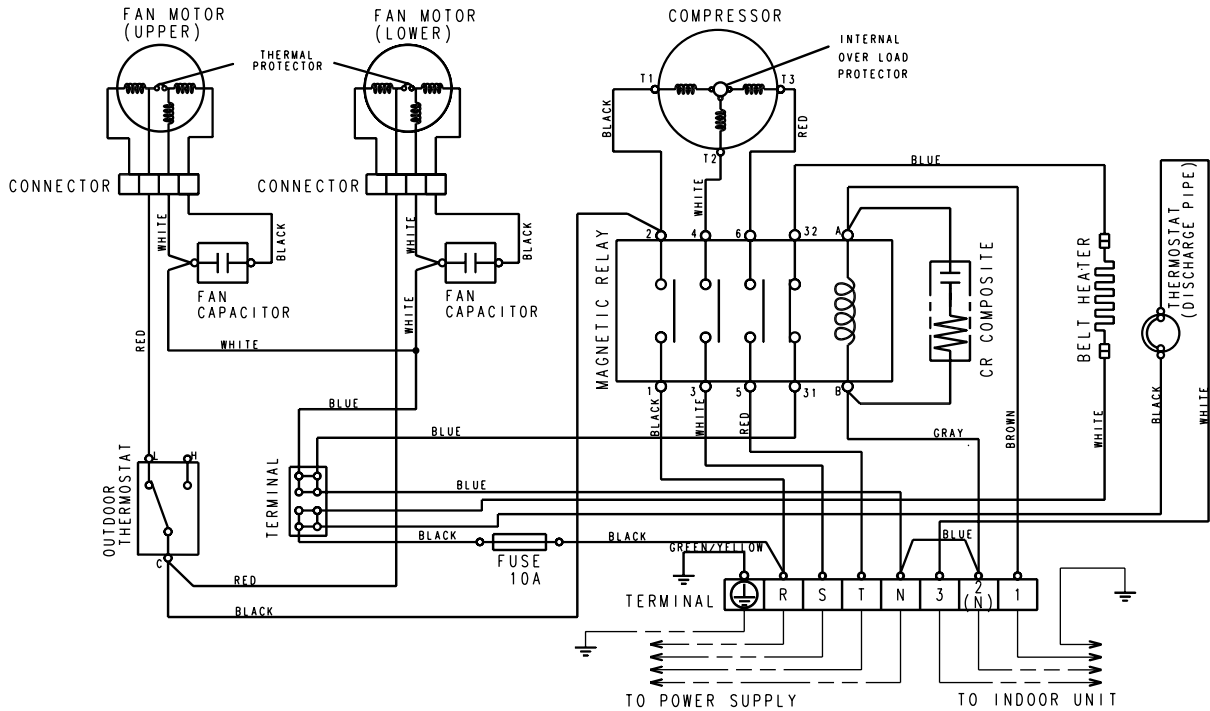

**Model : RD-60HC**

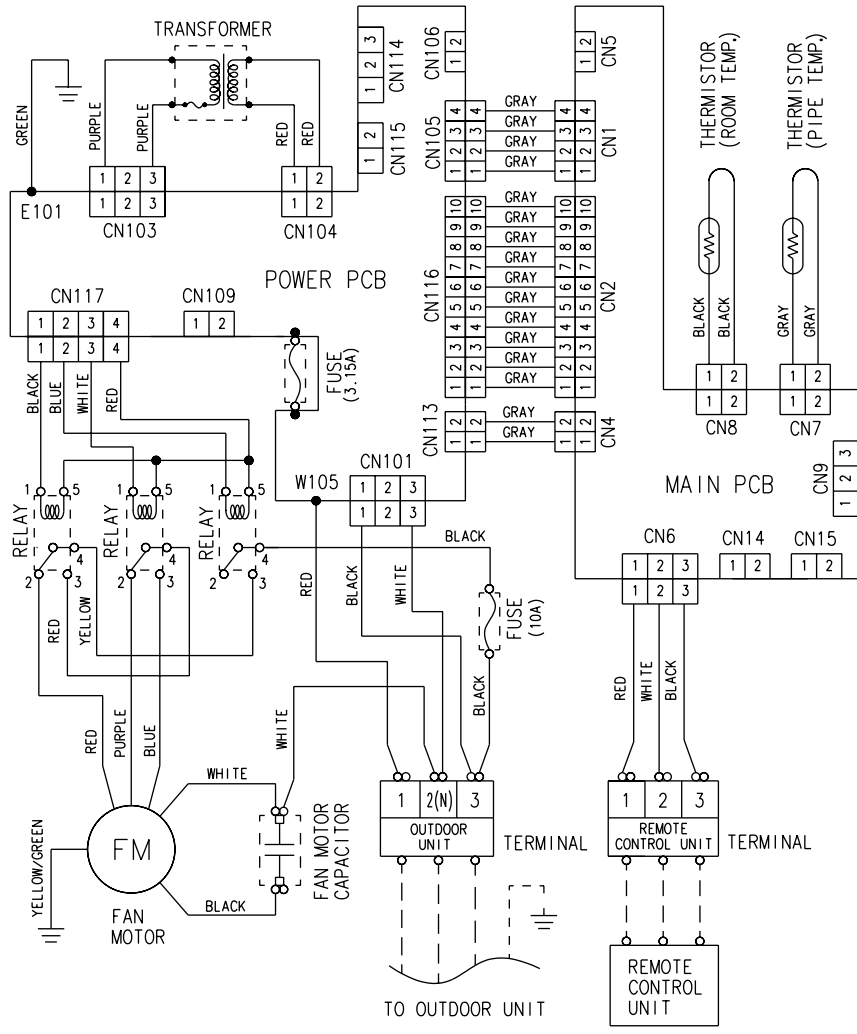

**Model : ROD-60HB**

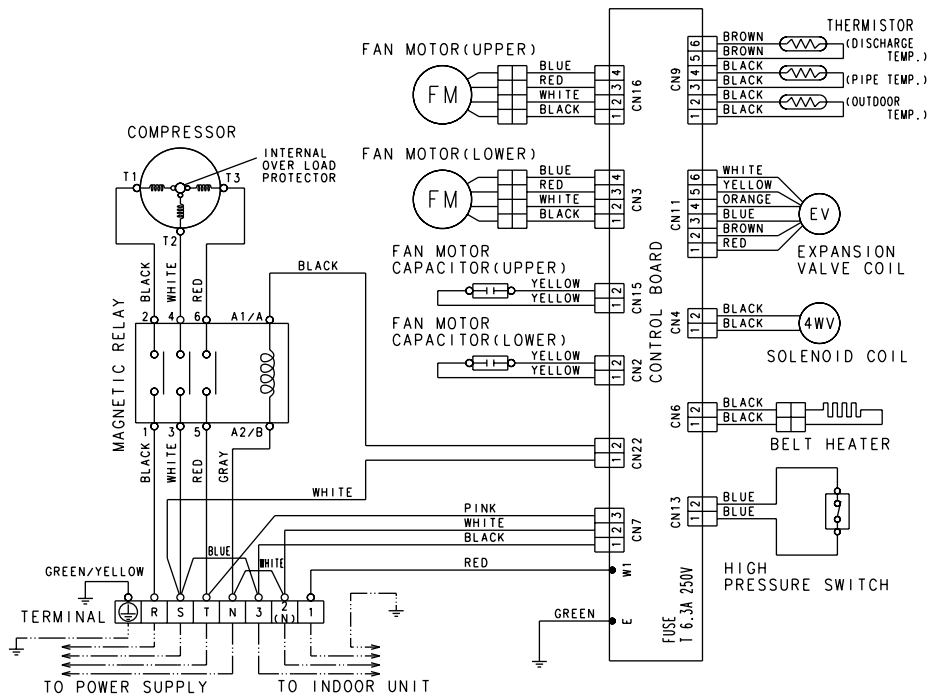

# INDOOR PRINTED CIRCUIT BOARD CIRCUIT DIAGRAM

Model : RD-60CC

## CONTROLLER PCB ASSEMBLY ( MAIN PCB ) EZ-00304WSE-C

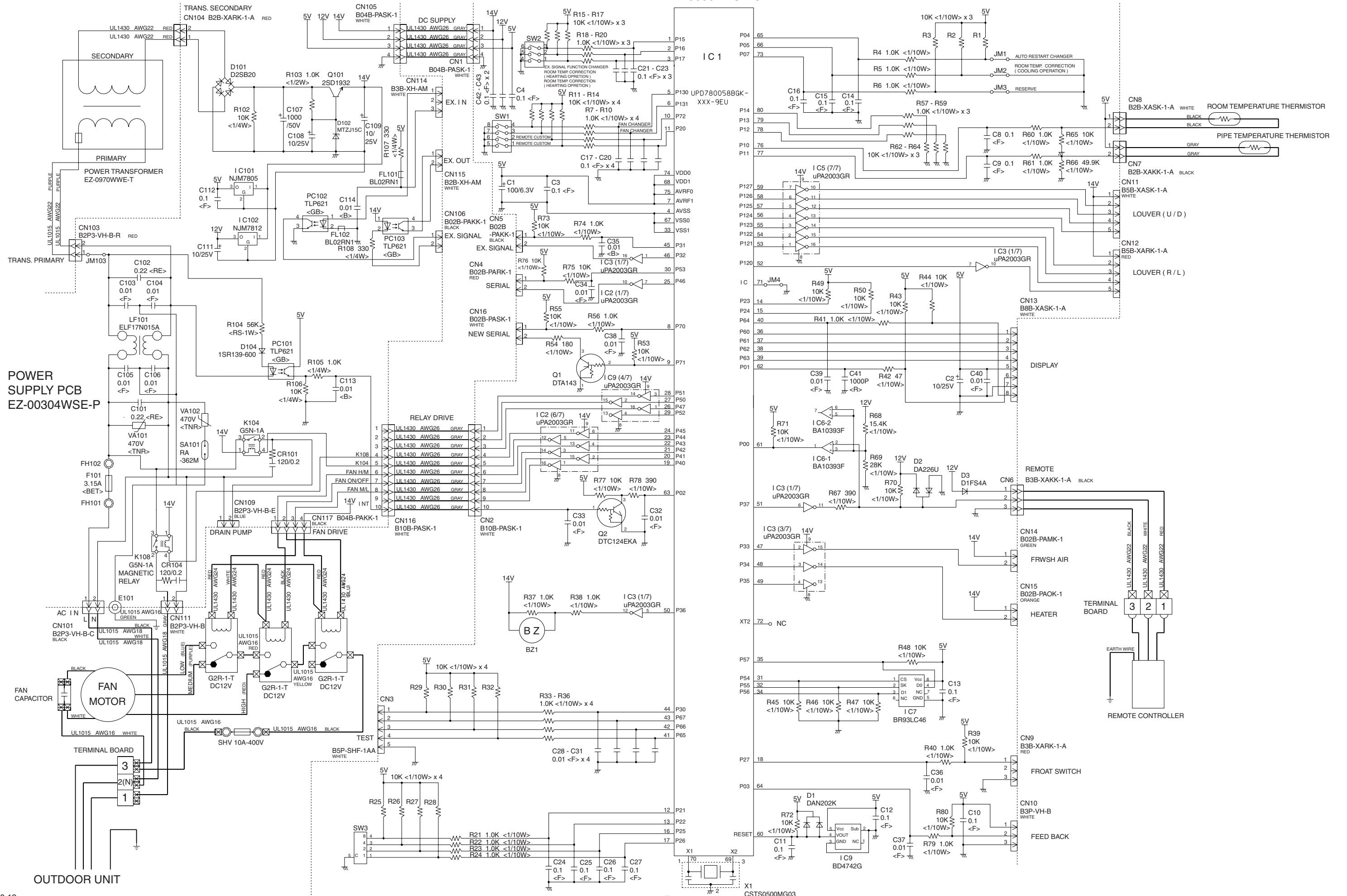



### CONTROLLER PCB ASSEMBLY ( MAIN PCB ) EZ-003SHSE-C

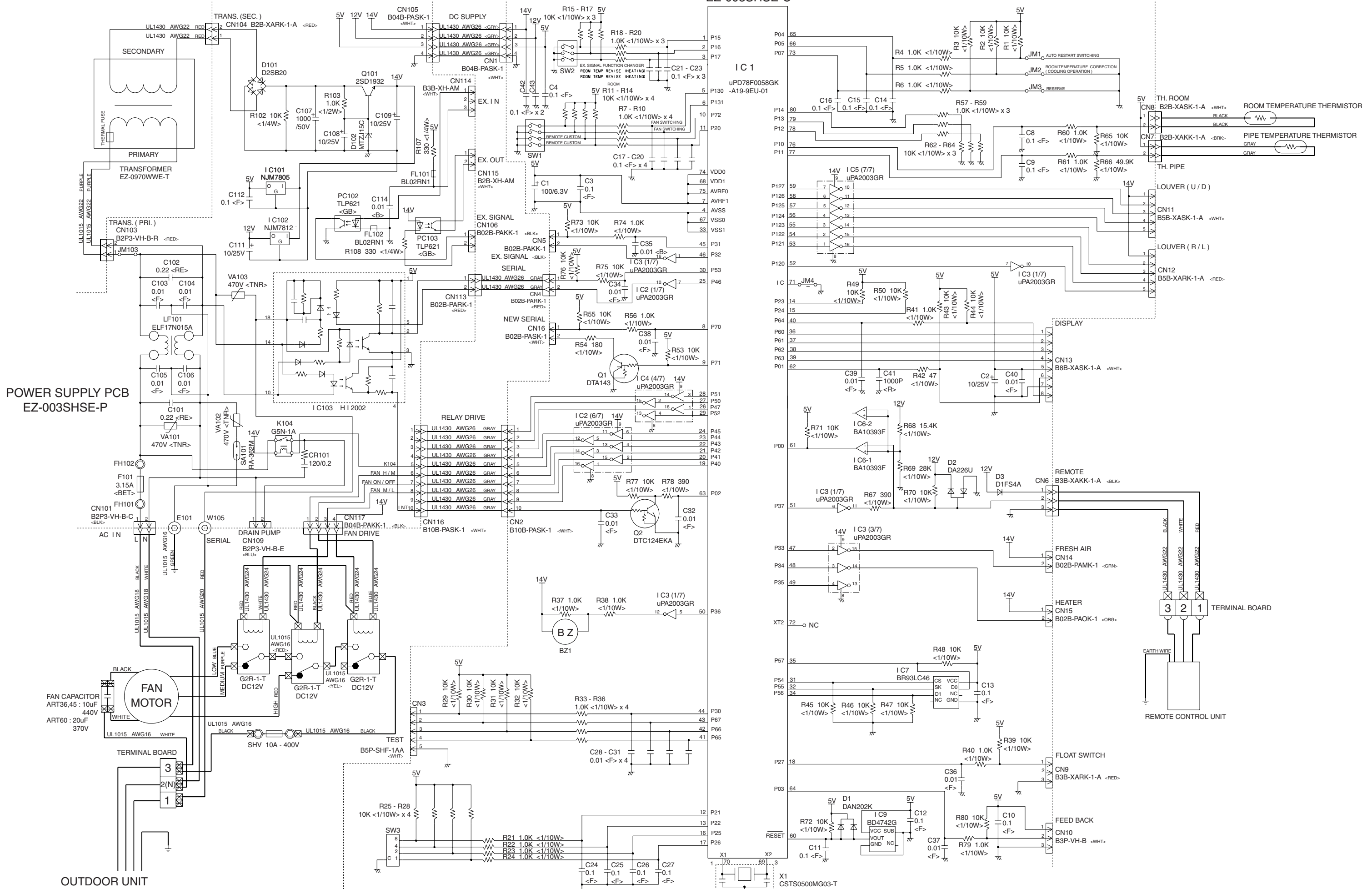

POWER SUPPLY PCB  
EZ-003SHSE-P

OUTDOOR UNIT

# OUTDOOR PRINTED CIRCUIT BOARD CIRCUIT DIAGRAM

Model : ROD-60HB

## CONTROLLER PCB ASSEMBLY ( MAIN PCB )

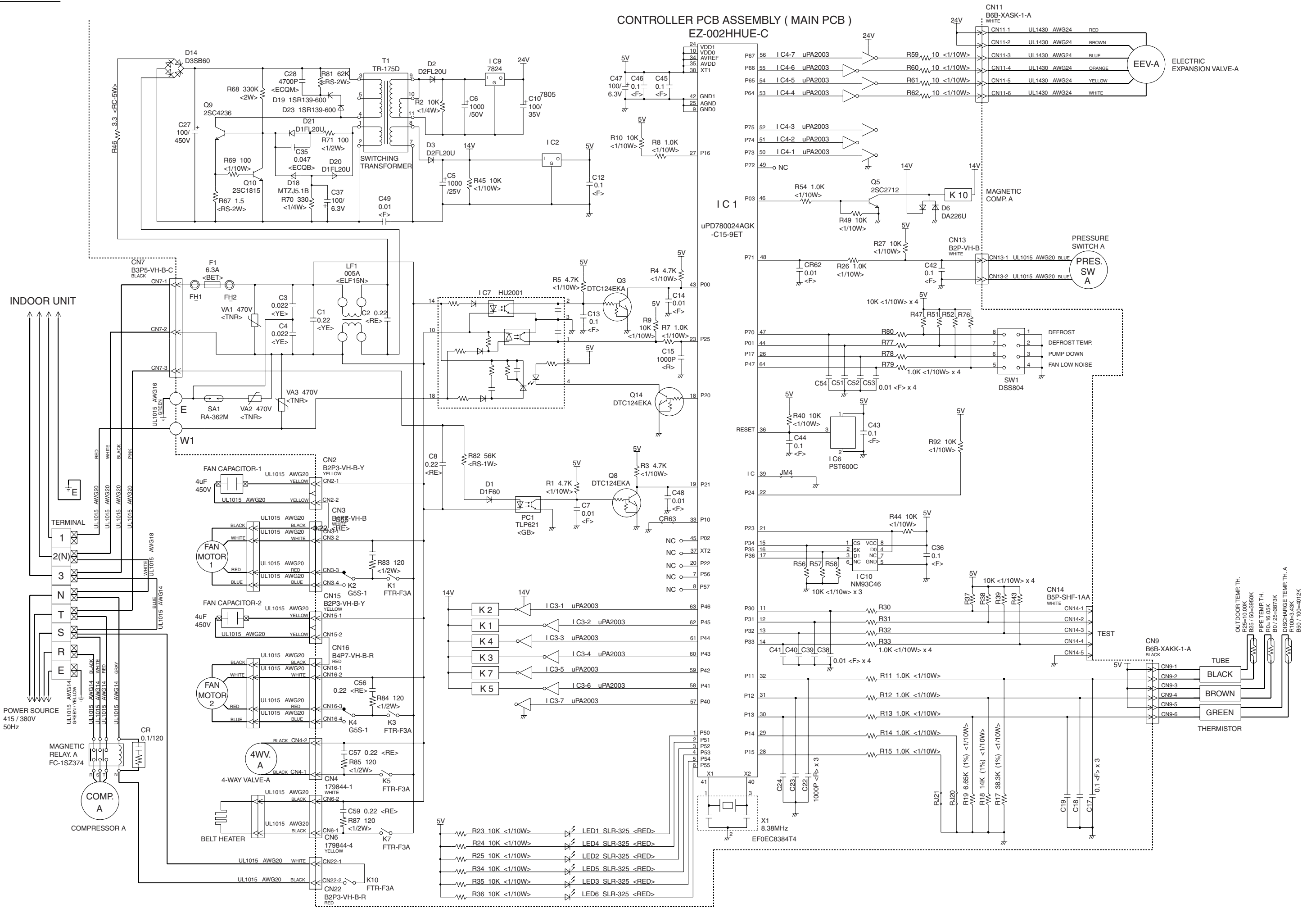

# DIP-SWITCH SETTING

## ●Indoor Unit

	NO.	SW state		Detail
		OFF	ON	
SW1 DIP-Switch	1	—	*	Out of Use
	2	—	*	
	3	—	*	
	4	—	*	

	NO.	SW state		Detail
		OFF	ON	
SW2 DIP-Switch	1	Ceiling setting(+4°C)*	Room setting(0°C)	Remote sensor setting
	2	Edge	Pulse	Control input setting
	3	Validity	Invalidity	Auto restart setting

	NO.	SW state		Detail
		Connect	Disconnect	
Jumper wire	JM1	—	*	Out Of Use
	JM2	Residencial	Commercial	Commercial mode setting
	JM3	Nomal	Heater setting	Heater setting

## ●Remote Controller

	NO.	SW state		Detail
		OFF	ON	
DIP-Switch	1		*	Dual remote controller setting
	2		*	
	3	One Unit	Multiple Unit	Group control setting
	4	Heat & Cool model	Cooling Only model	Model setting
	5	Invalidity	Validity	Auto changeover setting
	6	Invalidity	Validity	Memory backup setting

	NO.	SW state		Detail
		Connect	Disconnect	
Jumper wire	J5	3 speed (HI,MED,LO)	1 speed (HI)	Fan speed setting(for AR90)

\* : Factory setting

# ERROR DISPLAY

**⚠ CAUTION**

**Supply power to the crankcase heater for at least 12 hours before the start of operation in winter.**

- Stop the air conditioner operation.
- Press the master control button and the fan control button simultaneously for 2 seconds or more to start the test run.

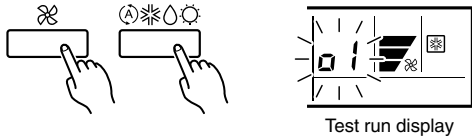

- Press the start/stop button to stop the test run.

## [SELF-DIAGNOSIS]

When the error indication E:EE is displayed, follow the following items to perform the self-diagnosis. E:EE indicates an error has occurred.

### 1. REMOTE CONTROLLER DISPLAY

- Stop the air conditioner operation.
- Press the set temperature buttons  $\wedge / \vee$  simultaneously for 5 seconds or more to start the self-diagnosis. Refer to the following tables for the description of each error code.

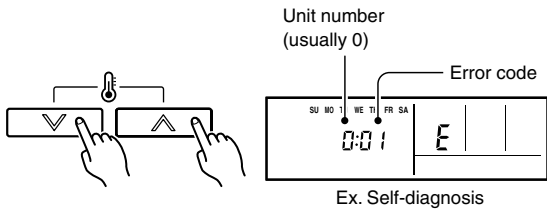

- Press the set temperature buttons  $\wedge / \vee$  simultaneously for 5 seconds or more to stop the self-diagnosis.

Error code	Error contents
<b>00</b>	Communication error (indoor unit ↔ remote controller)
<b>01</b>	Communication error (indoor unit ↔ outdoor unit)
<b>02</b>	Room temperature sensor open
<b>03</b>	Room temperature sensor short-circuited
<b>04</b>	Indoor heat exchanger temperature sensor open
<b>05</b>	Indoor heat exchanger temperature sensor short-circuited
<b>06</b>	Outdoor heat exchanger temperature sensor open
<b>07</b>	Outdoor heat exchanger temperature sensor short-circuited
<b>08</b>	Power source connection error

Error code	Error contents
<b>09</b>	Float switch operated
<b>0A</b>	Outdoor temperature sensor open
<b>0b</b>	Outdoor temperature sensor short-circuited
<b>0c</b>	Discharge pipe temperature sensor open
<b>0d</b>	Discharge pipe temperature sensor short-circuited
<b>0E</b>	Outdoor high pressure abnormal
<b>0F</b>	Discharge pipe temperature abnormal
<b>11</b>	Model abnormal
<b>12</b>	Indoor fan abnormal
<b>13</b>	Outdoor signal abnormal
<b>14</b>	Outdoor EEPROM abnormal

### 2. OUTDOOR UNIT LEDS

#### Heat & Cool model (reverse cycle) only

When a malfunction occurs in the outdoor unit, the LEDs on the circuit board light to indicate the error. Refer to the following table for the description of each error according to the LEDs.

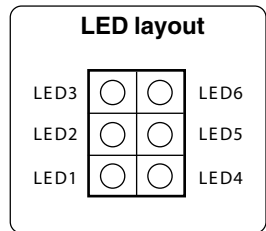

Error contents	LED1	LED2	LED3	LED4	LED5	LED6
Signal abnormal	—	—	×	○	×	×
Indoor unit abnormal	—	—	×	×	○	×
Discharge pipe temperature abnormal	—	—	×	×	×	○
Outdoor heat exchanger temperature abnormal	—	—	×	×	○	○
Outdoor temperature abnormal	—	—	×	○	×	○
Power source connection error	—	—	○	×	×	×
EEPROM abnormal	—	—	○	○	○	○
	◎	◎	◎	◎	◎	◎
Outdoor high pressure abnormal	○	—	—	—	—	—
Discharge pipe temperature abnormal	—	○	—	—	—	—

○: 0.5s ON/0.5s OFF (flash)      ×: OFF  
 ◎: 0.1s ON/0.1s OFF (flash)      —: Indefinite

When the fault is cleared, the LED lamp goes off. However, for discharge pipe temperature abnormal and high pressure abnormal, the LED lamp lights continuously for 24 hours, as long as the power is not turned off.

# DISASSEMBLY ILLUSTRATION (Indoor Unit)

Models : RD-60CC  
RD-60HC

---

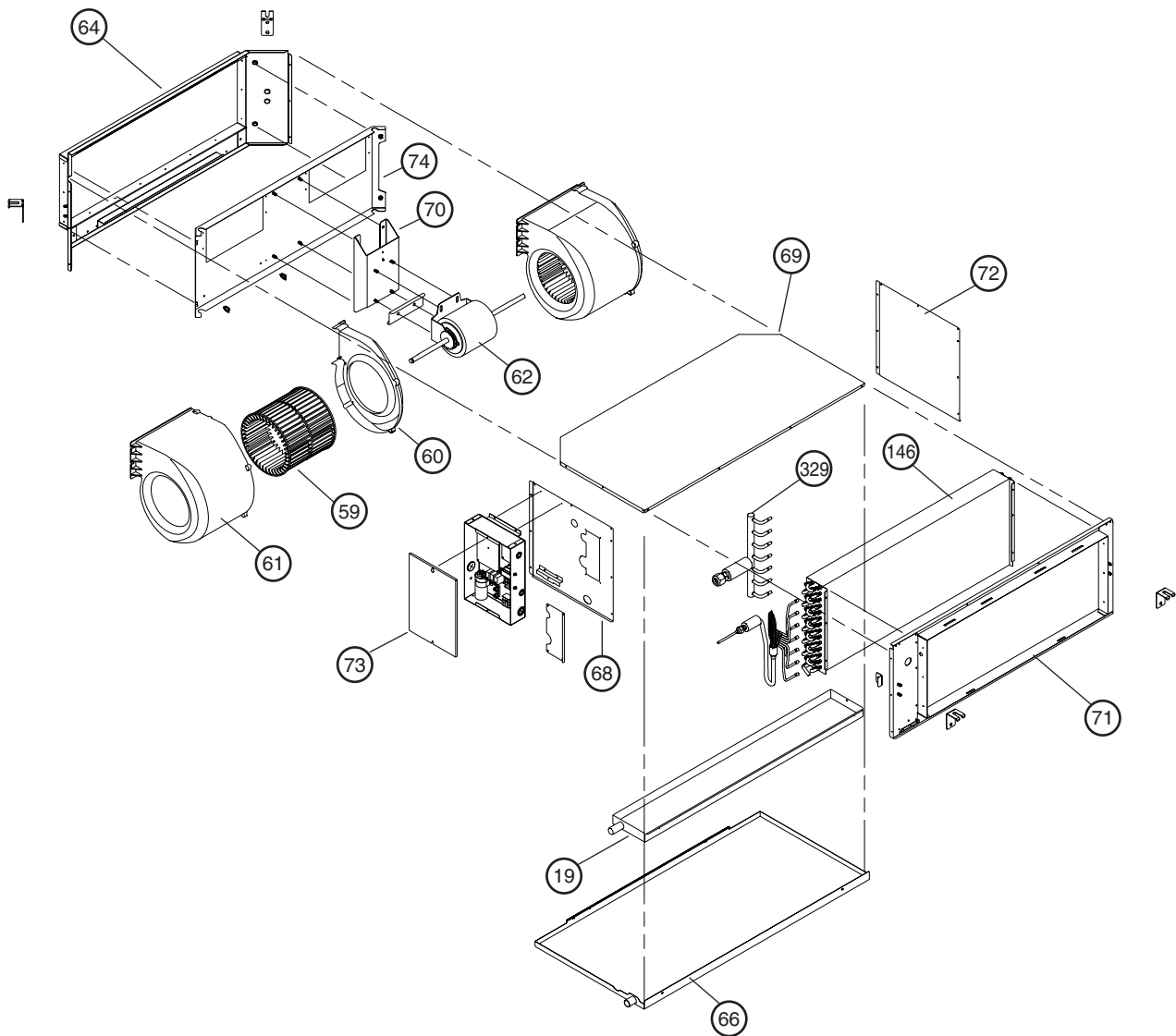



Models : ROD-60CB  
ROD-60HB

---

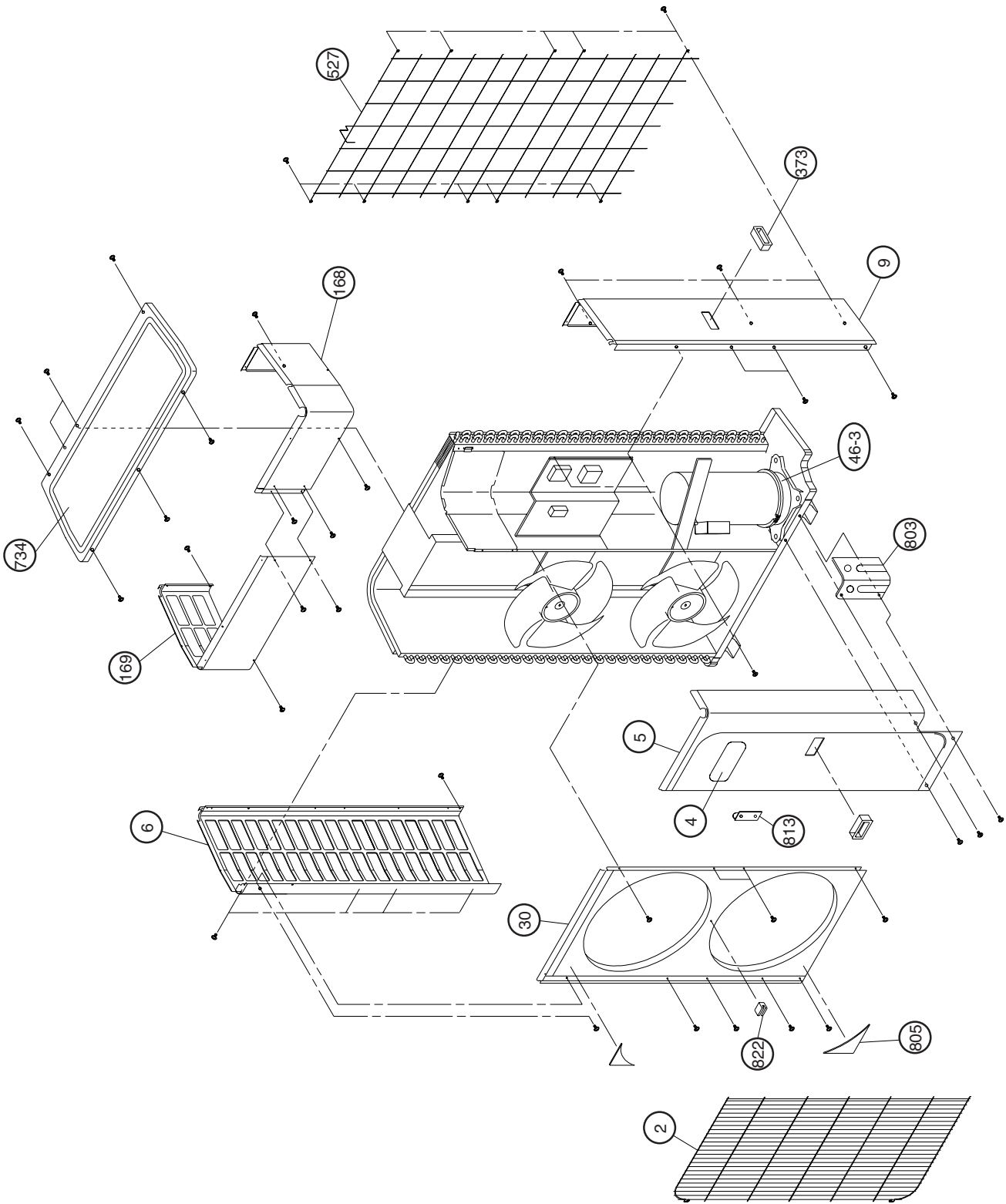

Model : ROD-60CB

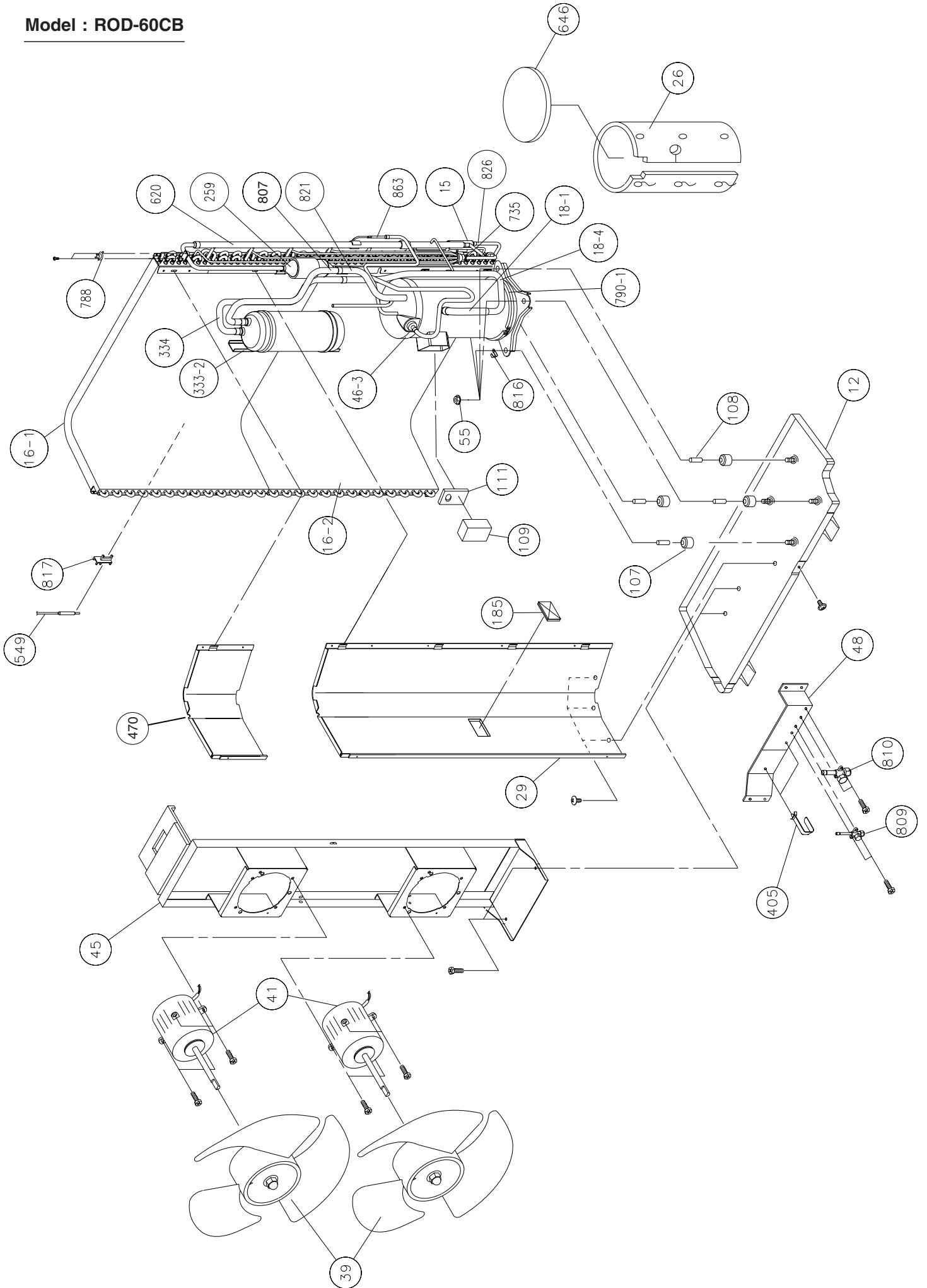



**Model : ROD-60HB**

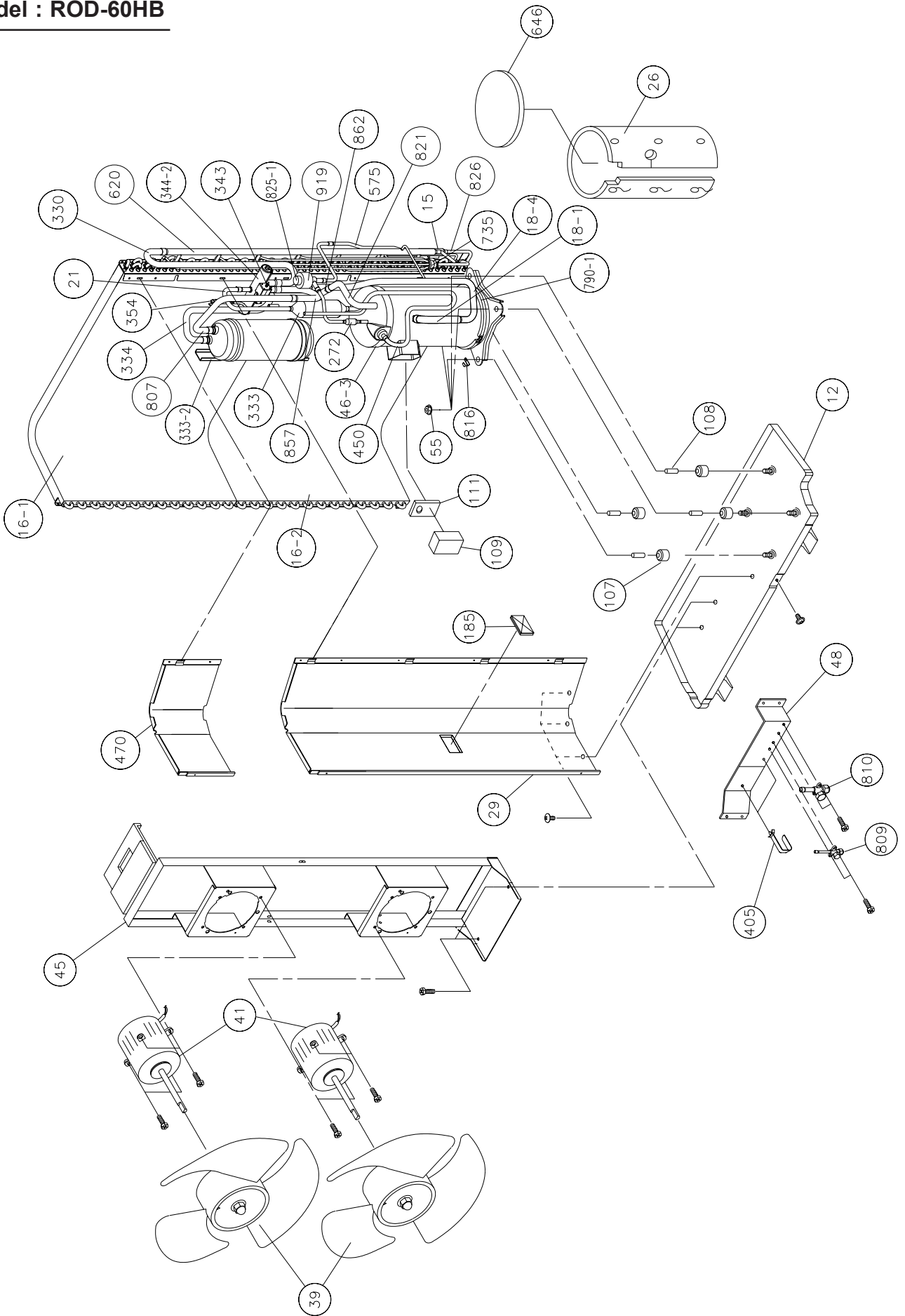

Model : ROD-60CB

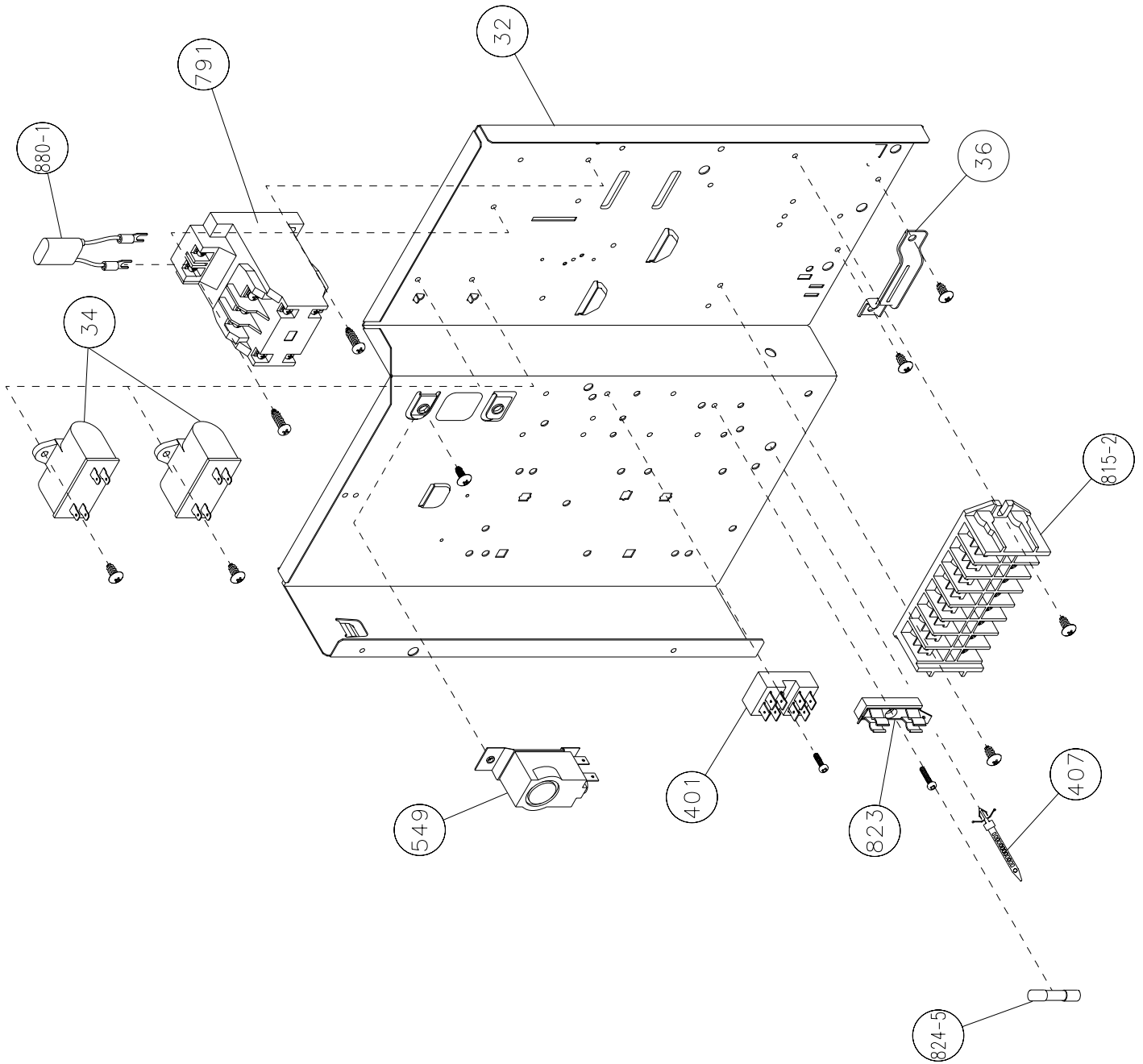

**Model : ROD-60HB**

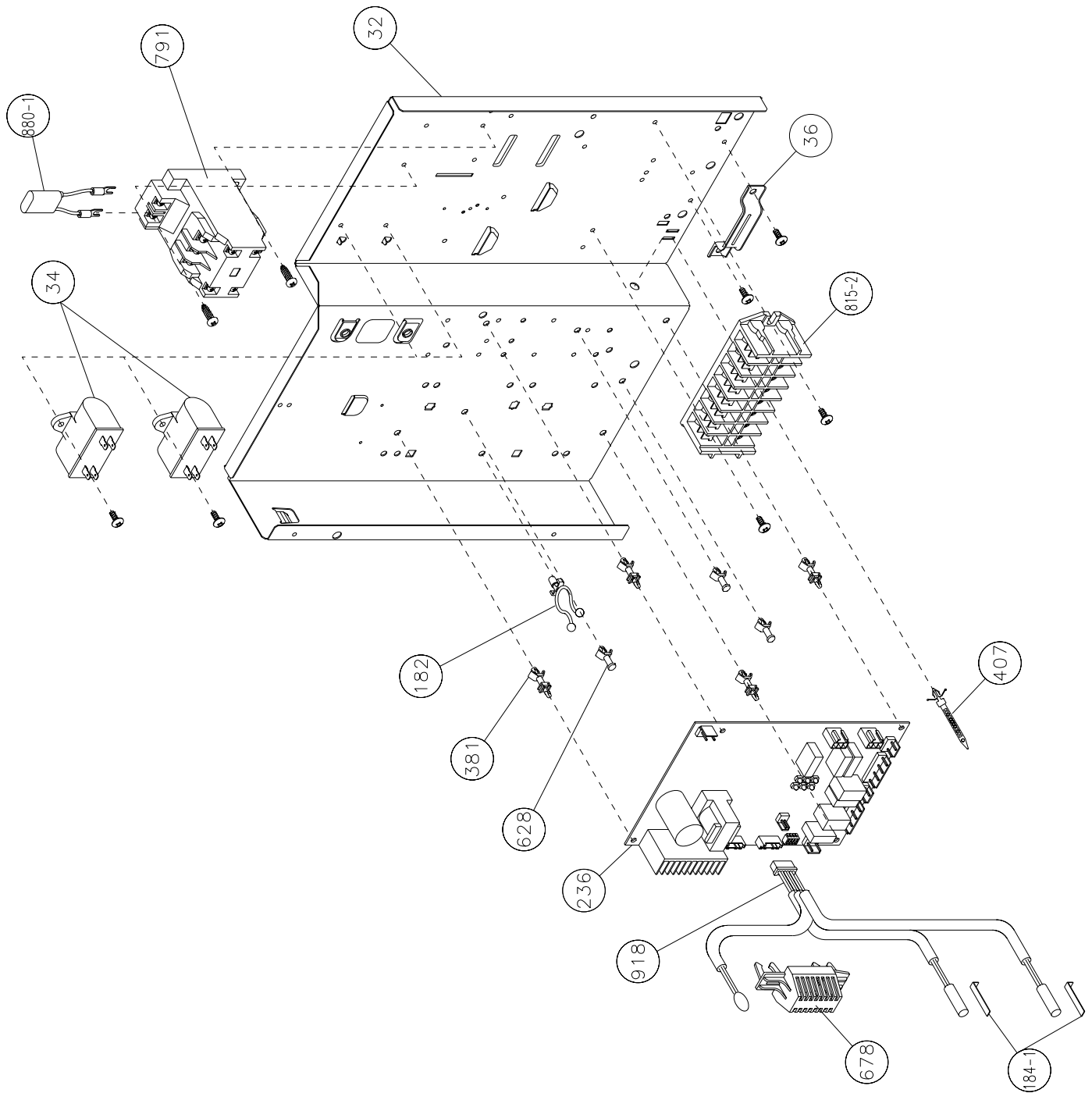

## PARTS LIST (Indoor unit)

Ref. No.	Description	Parts No.		Ord. Q'ty
		RD-60CC	RD-60HC	
19	DRAIN PAN ASSY PRINTED	9372047026	9372047026	
37	CAPACITOR, PLASTIC	9704436146	9704436146	
38	CAPACITOR CLAMP	9308114006	9308114006	
59	SIROCCO FAN	9372059012	9372059012	
60	CASING B	9372058015	9372058015	
61	CASING A	9372057018	9372057018	
62	MOTOR, INDUCT	9601688013	9601688013	
64	KIT (PANEL FRONT SUB ASSY)	9372637012	9372637012	
66	DRAIN PAN SUB ASSY	9372053003	9372053003	
68	KIT (PANEL RIGHT SUB ASSY)	9372916018	9372916018	
69	PLATE TOP SUB ASSY	9372576014	9372576014	
71	KIT (PANEL REAR SUB ASSY)	9372636015	9372636015	
70	BRACKET MOTOR ASSY	9372037003	9372037003	
72	KIT (PANEL LEFT SUB ASSY)	9372581018	9372581018	
73	COVER BOX	9372061008	9372061008	
74	PANEL FAN ASSY	9372035009	9372035009	
146	EVAPORATOR ASSY	9372585016	9372585016	
236	POWER PCB ASSY	9705271029	9705271012	
237	CONTROLLER PCB ASSY	9705246027	9705246010	
329	DISTRIBUTOR ASSY	(EZ-00304WSE-C) 9372587010	(EZ-003SHSE-C) 9372587010	
455	CONTROL BOX ASSY	9372536001	9372536001	
553	TRANSFORMER (POWER)	9704129017	9704129017	
815-1	TERMINAL 3P	9306489045	9306489045	
815-2	TERMINAL 3P	9703345012	9703345012	
823	FUSE HOLDER	0501454012	0501454012	
824-3	FUSE	0600222512	0600222512	
824-5	FUSE	0600315023	0600315023	
846	RELAY	9702100018	9702100018	
---	THERMO. SPRING-A	313728262708	313728262708	
---	PIPE THERMISTOR	9703297113	9703297113	
---	ROOM THERMISTOR	9703299216	9703299216	
---	REMOCON ASSY	9372266021	9372266014	

When you order parts, please make a photocopy of this page and fill the number of the parts in the "Order" column.

**OUTDOOR UNIT**

Ref. No.	Description	Part No.	Ord. Q'ty	Ref. No.	Description	Part No.	Ord. Q'ty
		ROD-60CB				ROD-60CB	
2	Fan Cover	9352159015		184-1	Thermo. Spring -A	313728262708	
4	Emblem-Rear	9361328006		185	Rubber Bushing	313005066051	
5	Cabinet-A, Painted	9352146015		259	Muffler	9368082000	
6	Cabinet-C, Painted	9352149016		333-2	Accumulator(B)	9371615011	
9	Cabinet-B, Painted	9352147012		334	Suction Pipe-B	9352287008	
12	Base Assy, Painted	9352136016		373	Grip	9352157004	
15	Dryer	9368111014		401	Terminal-2P	9701971015	
16-1	Condenser-A Assy	9369546006		405	Clamp No. 1763	313816345304	
16-2	Condenser-B Assy	9369547003		407	Clamp (Cable) No. 1259	313739340109	
18-1	Suction Pipe-A	9364513003		470	Separate Wall-B Assy	9361310001	
18-4	Suction Pipe	9364054001		527	Protection Net	9361730007	
26	Compressor Cover-A	9370774030		549	Thermister Outdoor	9352426001	
29	Separate Wall Assy	9355277013		620	Inlet Pipe (Condenser) Assy	9361558007	
30	Blower Cover, Painted	9352151019		646	Compressor Cover-B	9370774047	
32	Control Box Metal	9352134012		734	Cabinet Top Plate	9352161018	
34	Capacitor (Fan Motor)	9704305015		735	Distributor Assy	9361561007	
36	Cord Holder Metal	9356934007		788	Thermister - Over heat	9354061002	
39	Propeller Fan Assy	9366378013		790-1	Belt Heater-A	9361140042	
41	Fan Motor Assy	9600832028		791	Magnetic Relay	9900227012	
45	Bracket (Motor) Assy	9371639017		803	Cabinet-D, Painted	9352150012	
46-3	Compressor Assy	9370067002		805	Blower Cover Corner	9352160011	
48	Bracket (Coupler) Assy	9355281010		807	Inlet Pipe (Accumulator)	9352285004	
55	Special Nut M8	9355091008		809	Ball Valve-A	9371799049	
107	Rubber Seat-A (For Comp.)	9364084008		810	Ball Valve-B	9371799056	
108	Sleeve-A (For Comp.)	9364085005		813	Cabinet Hook	9352148002	
109	Terminal Cover (For Comp.)	9364087009		815-2	Terminal 8P	9363276022	
111	Terminal Packing (For Comp.)	9364086002		816	Wire Clamp Metal	313584219902	
168	Cabinet-E, Painted	9361312029		817	Thermostat Fixture	9352164019	
169	Cabinet-F, Painted	9361311022		821	Joint Pipe B	9352284007	
182	Clamp No.249	313361271505		822	Fan Cover Fixture-A	9352158018	
				823	Fuse Holder	0501454012	
				824-5	Fuse	0600315023	
				826	Condensing Pipe-B	9361557000	
				880-1	Network	9700987017	
				863	Joint Pipe (Capillary)-B	9353206008	

When you order parts, please make a photocopy of this page and fill the number of the parts in the "Order" column.





**OUTDOOR UNIT**

Ref. No.	Description	Part No.	Ord. Q'ty	Ref. No.	Description	Part No.	Ord. Q'ty
		ROD-60HB				ROD-60HB	
2	Fan Cover	9352159015		344-2	4-Way Valve	9353532008	
4	Emblem-Rear	9361328006		354	Pressure Switch	9704045003	
5	Cabinet-A, Painted	9352146015		373	Grip	9352157004	
6	Cabinet-C, Painted	9352149016		381	Locking Spacer	313209391506	
9	Cabinet-B, Painted	9352147012		405	Clamp No. 1763	313816345304	
12	Base Assy, Painted	9352136016		407	Clamp (Cable) No. 1259	313739340109	
15	Dryer	9368111014		450	Discharge Pipe A	9368338008	
16-1	Condenser-A Assy	9371389103		470	Separate Wall-B Assy	9361310001	
16-2	Condenser-B Assy	9371389097		527	Protection Net	9361730007	
18-1	Suction Pipe-A	9364513003		575	Condensing Pipe C	9363460001	
18-4	Suction Pipe	9364054001		620	Inlet Pipe (Condenser) Assy	9361558007	
21	Discharge Pipe-B Assy	9368331009		628	Locking Spacer-B	313005446558	
26	Compressor Cover-A	9370774030		646	Compressor Cover-B	9370774047	
29	Separate Wall Assy	9355277013		678	Bracket (Thermistor)	313557406106	
30	Blower Cover, Painted	9352151019		734	Cabinet Top Plate	9352161018	
32	Control Box Metal	9352134012		735	Distributor Assy	9361561007	
34	Capacitor (Fan Motor)	9704305015		790-1	Belt Heater-A	9361140042	
36	Cord Holder Metal	9356934007		791	Magnetic Relay	9900227012	
39	Propeller Fan Assy	9366378013		803	Cabinet-D, Painted	9352150012	
41	Fan Motor Assy	9600832028		805	Blower Cover Corner	9352160011	
45	Bracket (Motor) Assy	9371639017		807	Inlet Pipe (Accumulator) A	9363458008	
46-3	Compressor Assy	9370067002		809	Ball Valve-A	9371799049	
48	Bracket (Coupler) Assy	9355281010		810	Ball Valve-B	9371799056	
55	Special Nut M8	9355091008		813	Cabinet Hook	9352148002	
107	Rubber Seat-A (For Comp.)	9364084008		815-2	Terminal 8P	9363276022	
108	Sleeve-A (For Comp.)	9364085005		816	Wire Clamp Metal	313584219902	
109	Terminal Cover (For Comp.)	9364087009		821	Joint Pipe (Valve-B)	9353307002	
111	Terminal Packing (For Comp.)	9364086002		822	Fan Cover Fixture-A	9352158018	
168	Cabinet-E, Painted	9361312029		825-1	Expansion Valve	9900170028	
169	Cabinet-F, Painted	9361311022		826	Condensing Pipe-B	9361557000	
182	Clamp No.249	313361271505		857	Inlet Pipe (Accumulator) B	9363459005	
184-1	Thermo. Spring -A	313728262708		862	Valve-B Coupl. Pipe	9353309006	
185	Rubber Bushing	313005066051		880-1	Network	9700987017	
236	Controller PCB Assy	9704764096		918	Thermistor Assembly	9900129019	
272	Strainer Assy	9354139008		919	Expansion Valve Coil	9900172015	
330	Inlet Pipe (Cond. )-A	9361573000					
333	Accumulator	9350363018					
333-2	Accumulator(B)	9371615011					
334	Suction Pipe-B	9352287008					
343	Solenoid Coil	9359616108					





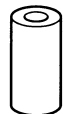
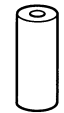
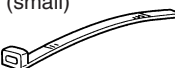
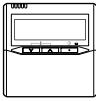

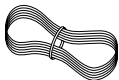

When you order parts, please make a photocopy of this page and fill the number of the parts in the "Order" column.

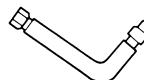
# STANDARD ACCESSORIES

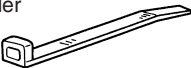
## INDOOR UNIT ACCESSORIES

Name and Shape	Q'ty	Application
Special nut A (large flange) 	4	For suspending the indoor unit from ceiling
Special nut B (small flange) 	4	
Coupler heat insulation (large) 	1	For indoor side pipe joint (large pipe)
Coupler heat insulation (small) 	1	For indoor side pipe joint (small pipe)
Binder (small) 	1	For fixing the remote controller cord
Remote controller 	1	
Tapping screw (flush heads) 	2	For installing the remote controller
Remote controller cord 	1	For connecting the remote controller

## OUTDOOR UNIT ACCESSORIES

Name and Shape	Q'ty	Application
Power cap 	1	For power supply cord installation
Auxiliary pipe assembly 	1	For wiring conduit (gas side) connection (May not be supplied, depending on the model)
Edge cover 	1	For wiring conduit installation hole edge protection
Tapping screw 	2	<ul style="list-style-type: none"> <li>• For cabinet A and cabinet D mounting (1)</li> <li>• Spare (1)</li> </ul>
Binder 	1	For power supply cord binding
Putty 	1	For sealing
Coupler heat insulation 	1	For outdoor side pipe joint
Pipe (drain) 	2	For outdoor unit drain piping work (May not be supplied, depending on the model.)
Flexible tube 	2	
Cap (drain) 	2	

