

FUJII
ELECTRIC

**SPLIT TYPE AIR
CONDITIONER (50Hz)**

DUCT type

**SERVICE
MANUAL**

Models	Indoor unit	Outdoor unit
	RD-45CA	RO-45CB
	RD-45HA	RO-45HB

CONTENTS

SPECIFICATIONS	1
CIRCUIT DIAGRAM	2
REFRIGERANT SYSTEM DIAGRAM	4
ERROR CONTENTS	5
INDOOR P. C. BOARD CIRCUIT DIAGRAM	6
DISASSEMBLY ILLUSTRATION	9
PARTS LIST	18

SPECIFICATIONS

INDOOR UNIT		RD-45CA	RD-45HA
OUTDOOR UNIT		RO-45CB	RO-45HB
COOLING CAPACITY	(kW)	12.4 - 12.7	12.4 - 12.7
HEATING CAPACITY	(kW)	—	13.4 - 13.7

ELECTRICAL DATA

POWER SOURCE	(V)	380 - 415	
FREQUENCY	(Hz)	50	
RUNNING CURRENT	(A)	COOLING	8.10 - 8.30
		HEATING	—
INPUT WATTS	(kW)	COOLING	4.50 - 4.57
		HEATING	—
E.E.R.	(kW/kW)	COOLING	2.76 - 2.78
		HEATING	—
MOISTURE REMOVAL	(ℓ /hr)	6.0	4.5
AIR CIRCULATION-Hi	(m³/hr)	2,200	2,200

COMPRESSOR

TYPE	Hermetic type, 2 pole, Three phase, Induction motor, Scroll
DISCRIMINATION	ZR61KC-TFD-559

FAN MOTOR

Indoor Unit	DISCRIMINATION	MFA-45BTT	
	HI-SPEED	(r.p.m.)	1,320
	MED-SPEED	(r.p.m.)	1,270
	LO-SPEED	(r.p.m.)	1,200
Outdoor Unit	DISCRIMINATION	MFB-362FT	
	HI-SPEED	(r.p.m.)	770
			790

DIMENSIONS

Indoor Unit	H x W x D	(mm)	270 x 1,210 x 700
Outdoor Unit		(mm)	1,152 x 940 x 370

WEIGHT

Indoor Unit	Net / Gross	(kg)	45 / 60
Outdoor Unit		(kg)	102 / 116
			110 / 124

REFRIGERANT CHARGE (R-22)

PIPE LENGTH		5 m (16 ft)	10 m (33 ft)	20 m (66 ft)	30 m (99 ft)	40 m (132 ft)	50 m (164 ft)
FULL CHARGE AMOUNT	RD-45CA		3,150 g (111.1 oz)		3,550 g (125.2 oz)	3,950 g (139.3 oz)	4,350 g (153.4 oz)
	RD-45HA		3,400 g (119.9 oz)		3,800 g (134.0 oz)	4,200 g (148.2 oz)	4,600 g (162.3 oz)

Notes : • Between 5 m and 50 m, when using a connection pipe other than that in the table, charge additional refrigerant with 40 g (1.41oz) / 1 m (3.3 ft) as the criteria.

- The above list shows values at the external static pressure of 10 mm Aq (98 Pa).

CIRCUIT DIAGRAM

Model : RD-45CA

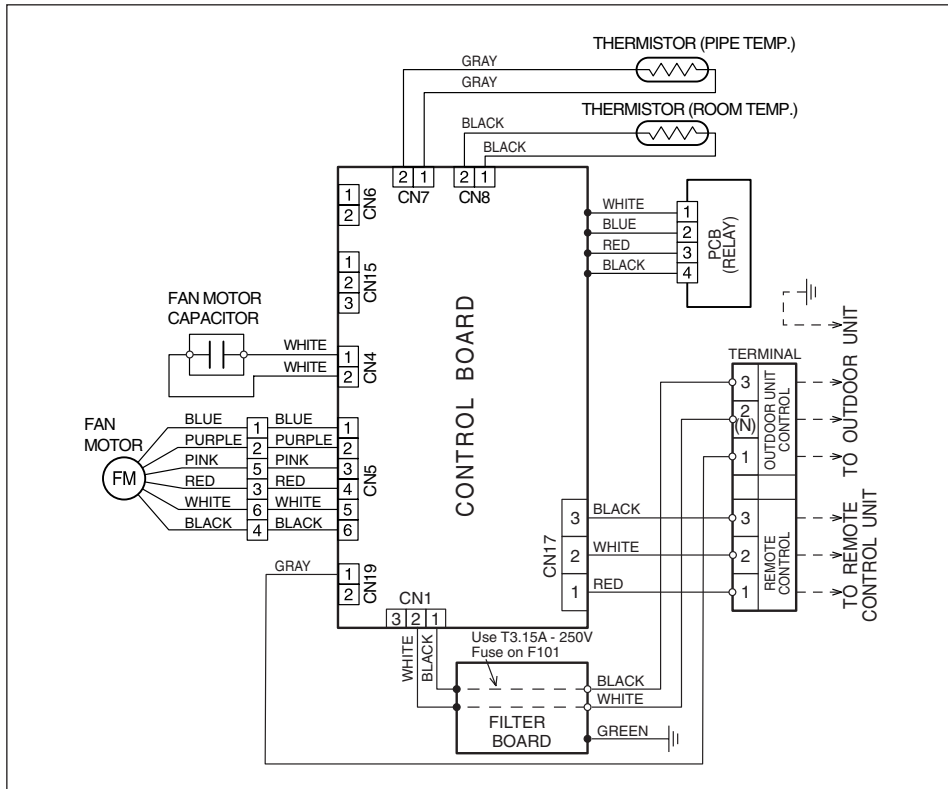

FAN MOTOR CAPACITOR	3.5 μ F
---------------------	-------------

Model : RO-45CB

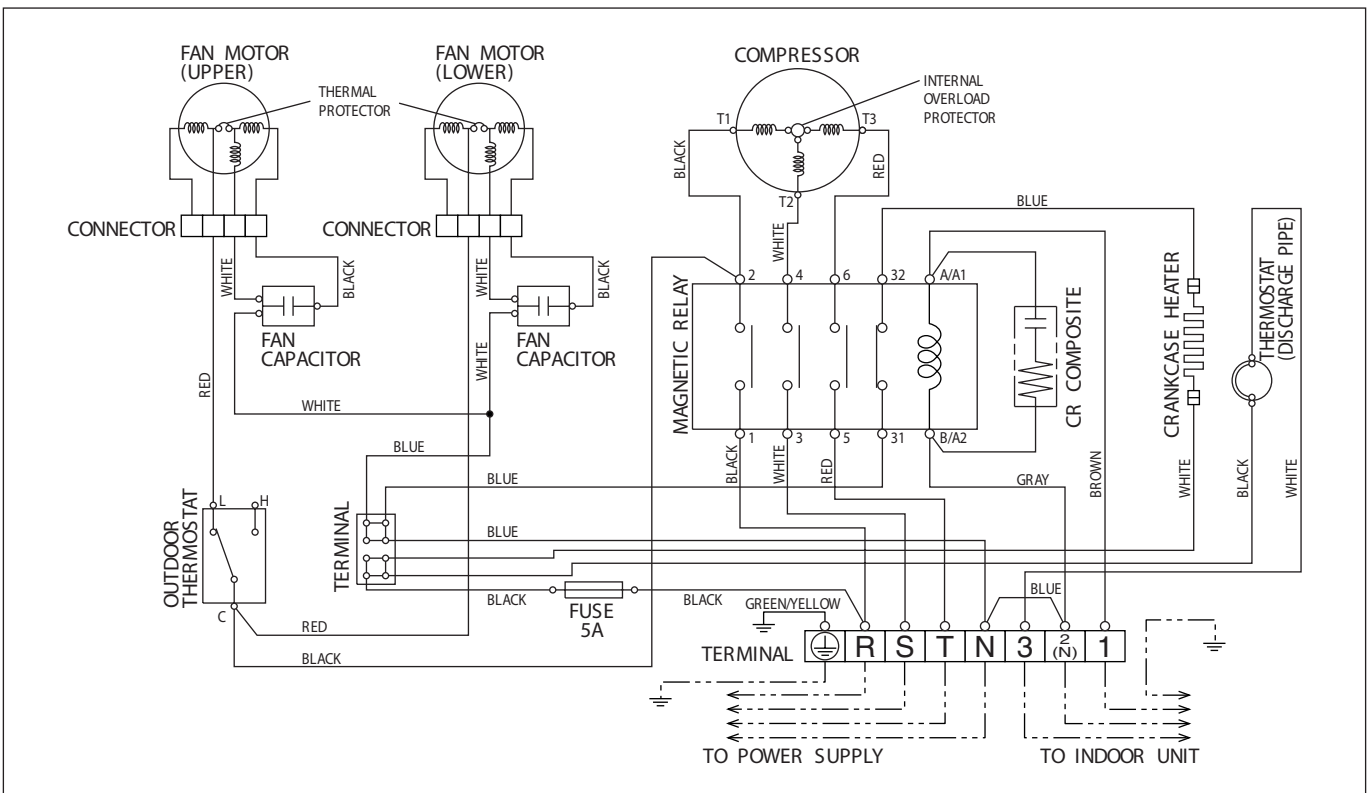

FAN MOTOR CAPACITOR	3.5 μ F
---------------------	-------------

Model : RD-45HA

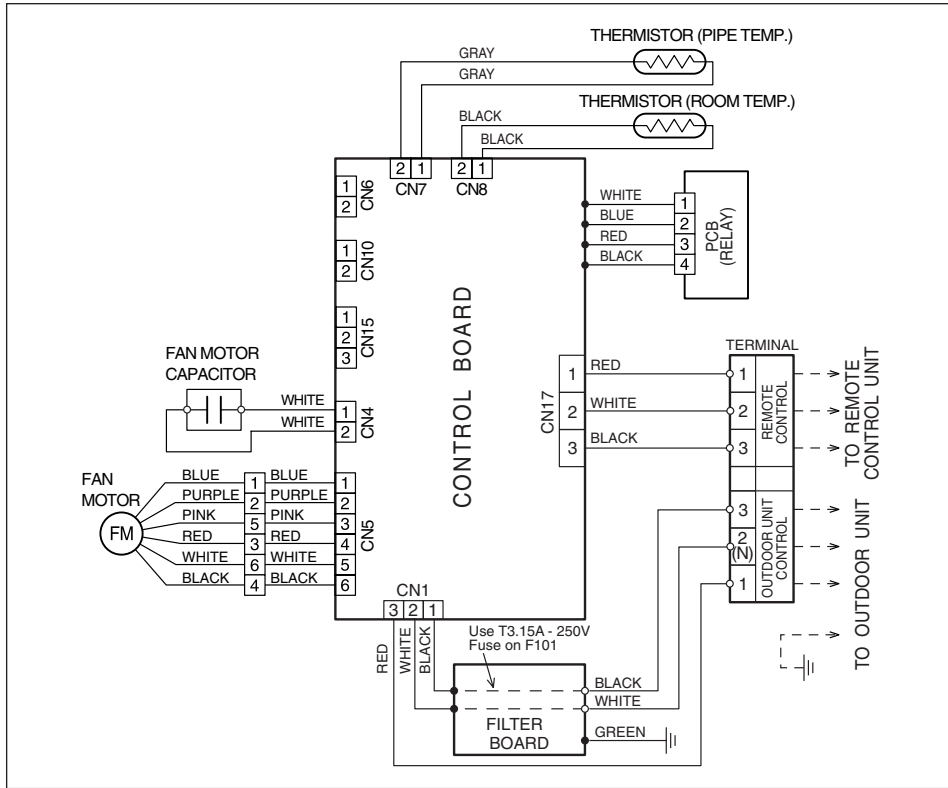

FAN MOTOR CAPACITOR	15.0 μF
----------------------------	-------------------------------

Model : RO-45HB

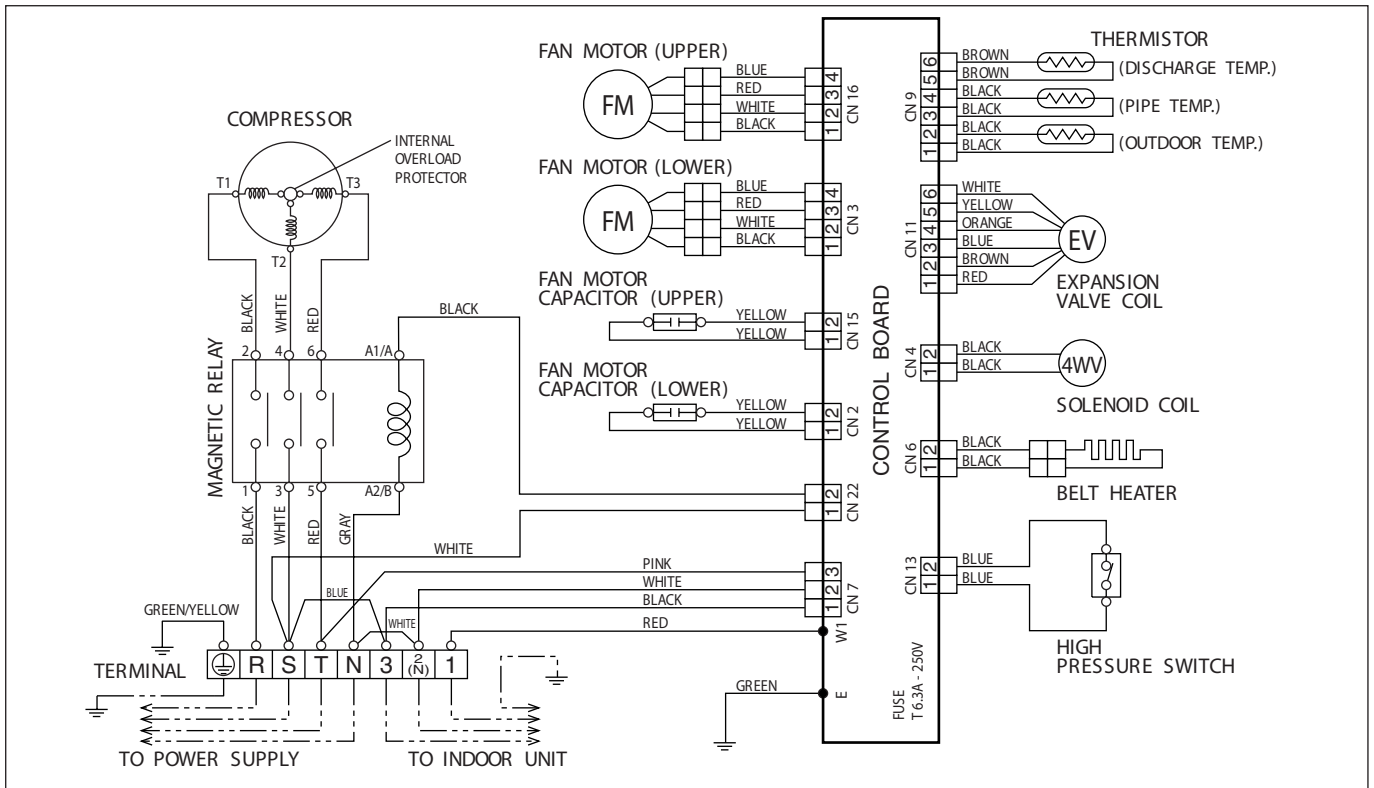

FAN MOTOR CAPACITOR	3.5 μF
----------------------------	------------------------------

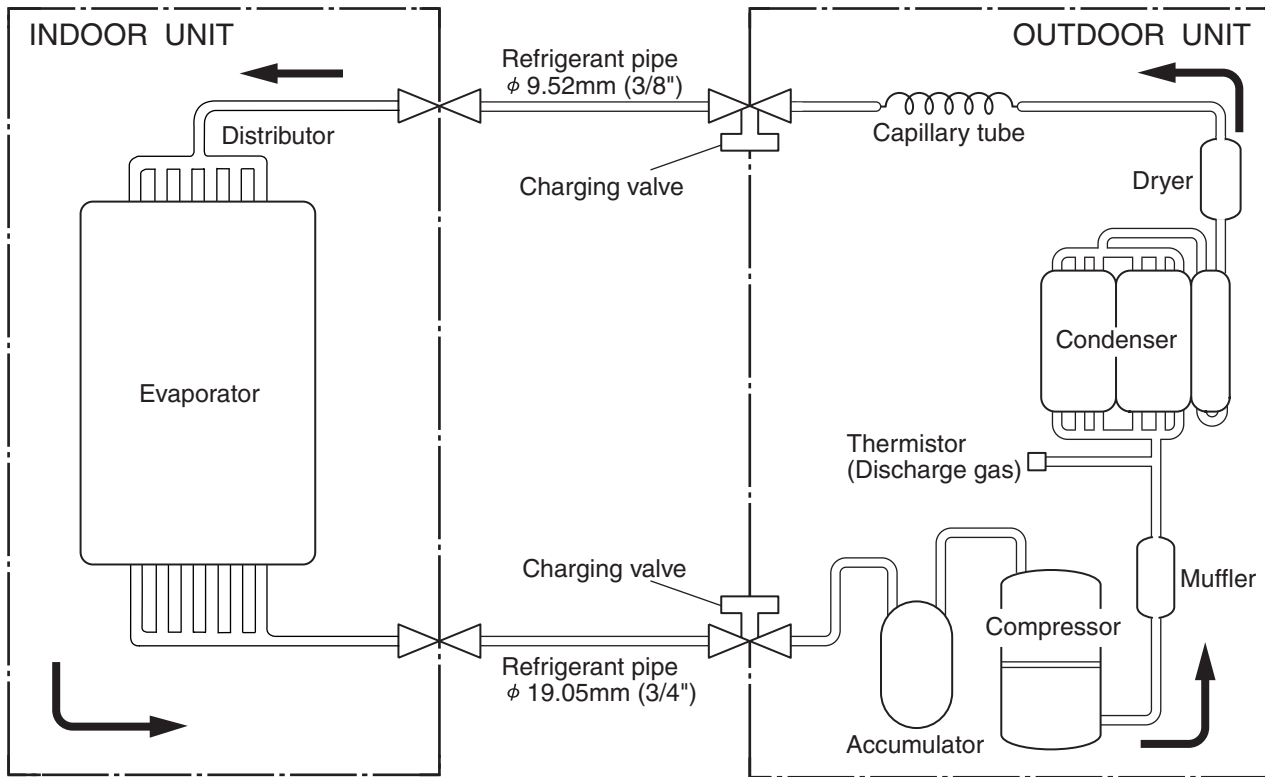

REFRIGERANT SYSTEM DIAGRAM

Models : RD-45CA / RO-45CB

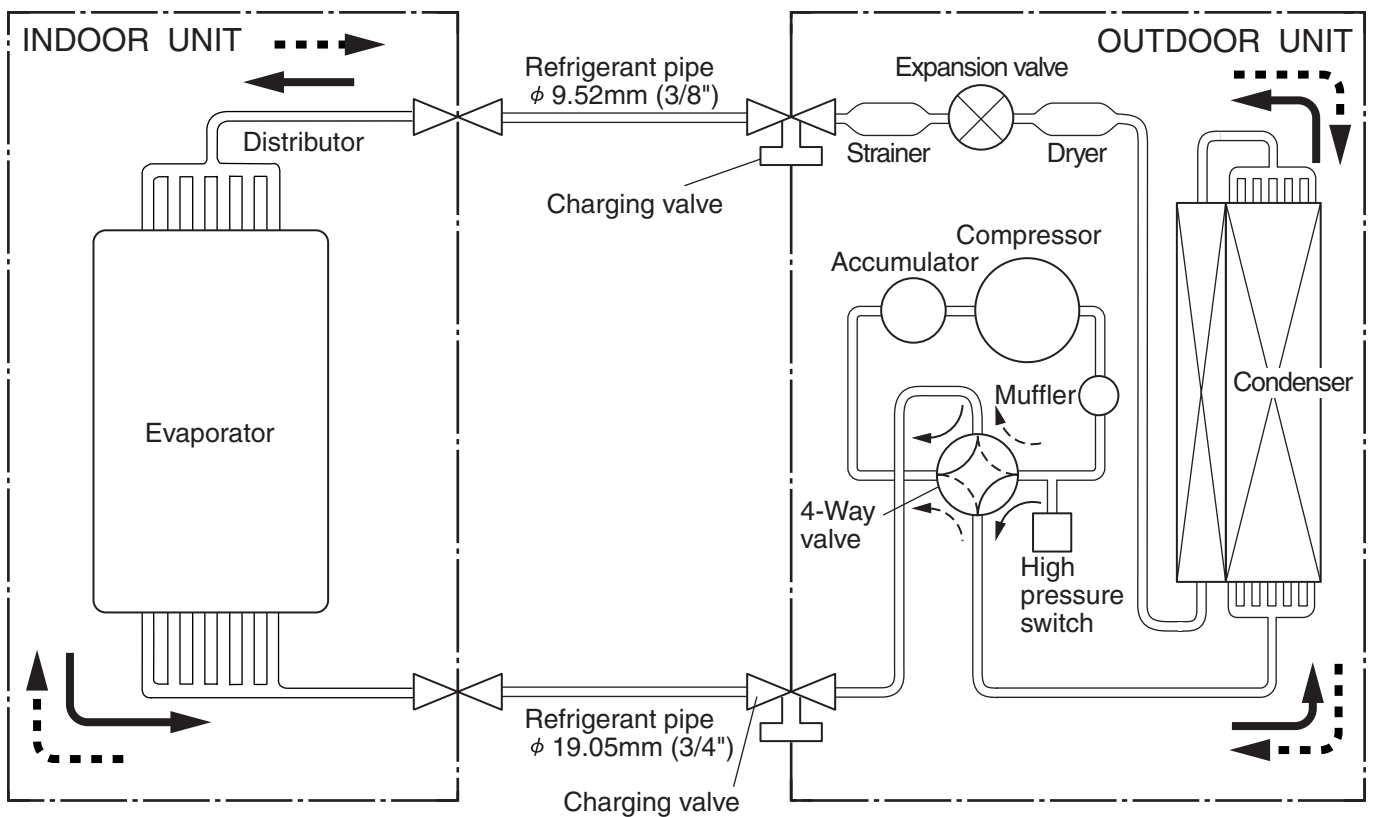

Models : RD-45HA / RO-45HB



 Cooling
 Heating
 : Flare coupling

ERROR CONTENTS

Models : RD-45CA / RO-45CB, RD-45HA / RO-45HB

1. REMOTE CONTROLLER

- When EE : EE blinks at the current time display, there is an error inside the air conditioner. If the SET TIME button (▼) and TEMP./DAY button (▼) are pressed simultaneously for more than three seconds, the self diagnosis check will start and the error contents will be displayed at the current time display. When the operation lamp lights, press the START/STOP button and after operation lamp goes off, perform the same operation. Process the error contents by referring to (Table 1).

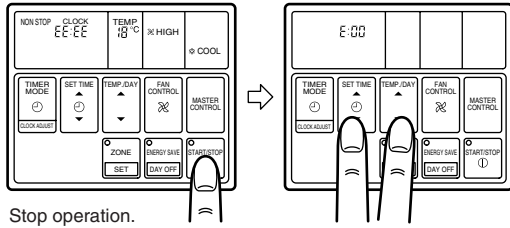

Table 1

Error cord	Error contents
E:00	Communication error (indoor unit ↔ remote controller)
E:01	Communication error (indoor unit ↔ outdoor unit)
E:02	Room temperature sensor open
E:03	Room temperature sensor shortcircuited
E:04	Indoor heat exchanger temperature sensor open
E:05	Indoor heat exchanger temperature sensor shortcircuited
E:06	Outdoor heat exchanger temperature sensor open
E:07	Outdoor heat exchanger temperature sensor shortcircuited
E:08	Power source connection error
E:09	Float switch operated
E:0A	Outdoor temperature sensor open
E:0B	Outdoor temperature sensor shortcircuited
E:0C	Discharge pipe temperature sensor open
E:0D	Discharge pipe temperature sensor shortcircuited
E:0E	Outdoor high pressure abnormal
E:0F	Discharge pipe temperature abnormal
E:11	Model abnormal
E:12	Indoor fan abnormal
E:13	Outdoor signal abnormal
E:14	Outdoor EEPROM abnormal

- To stop test running, press the START/STOP button.
- For the operation method, refer to the operating manual and perform operation check.
- Check that there are no abnormal sounds or vibration sounds during test running.

2. OUTDOOR UNIT

When the outdoor temperature drops, the outdoor unit's fans may switch to low speed, or one of the fans may stop intermittently.

ERROR : Heat & Cool model (Reverse cycle) only

The LED lamps operate as follows (Table 2) according to the error contents.

The LED lamps are on the outdoor unit board.

Table 2

Error contents	LED1	LED2	LED3	LED4	LED5	LED6
Signal abnormal	–	–	X	○	X	X
Indoor unit abnormal	–	–	X	X	○	X
Discharge pipe temperature abnormal	–	–	X	X	X	○
Outdoor heat exchanger temperature abnormal	–	–	X	X	○	○
Outdoor temperature abnormal	–	–	X	○	X	○
Power source connection error	–	–	○	X	X	X
EEPROM abnormal	–	–	○	○	○	○
	◎	◎	◎	◎	◎	◎
Outdoor high pressure abnormal	○	–	–	–	–	–
Discharge pipe temperature abnormal	–	○	–	–	–	–

- : 0.5s ON / 0.5s OFF (flash) X : OFF
- ◎ : 0.1s ON / 0.1s OFF (flash) – : Indefinite

When the fault is cleared, the LED lamp goes off.

However, for discharge pipe temperature abnormal and high pressure abnormal, the LED lamp lights continuously for 24 hours, as long as the power is not turned off.

ERROR LED DISPLAY LAYOUT

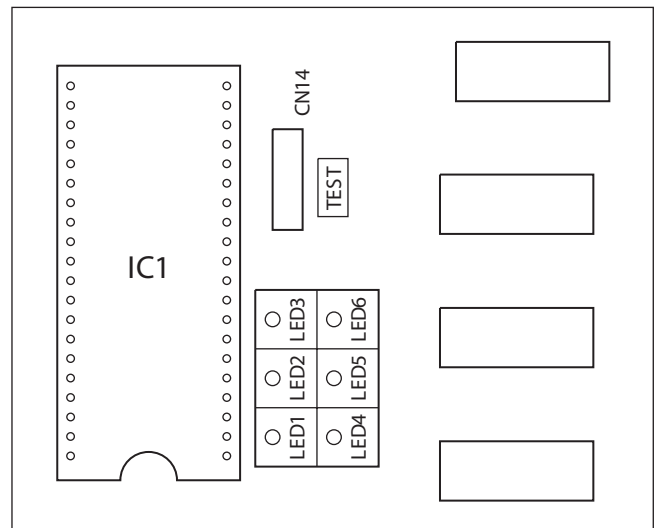

INDOOR PRINTED CIRCUIT BOARD CIRCUIT DIAGRAM

Model : RD-45CA

CONTROLLERPCB ASSEMBLY (MAIN PCB) EZ-002EWSE-C

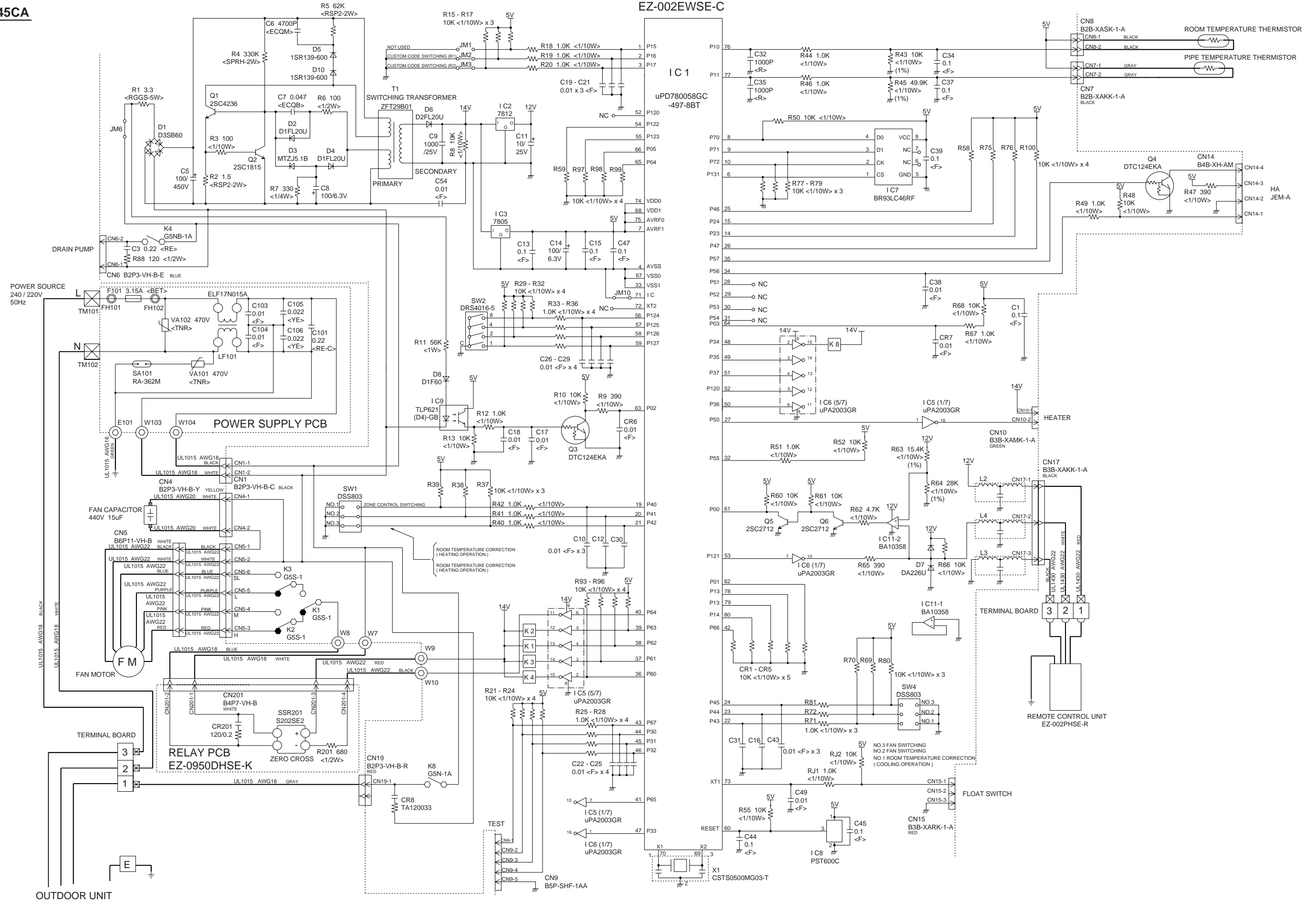

CONTROLLER PCB ASSEMBLY (MAIN PCB)

EZ-002PHSE-C

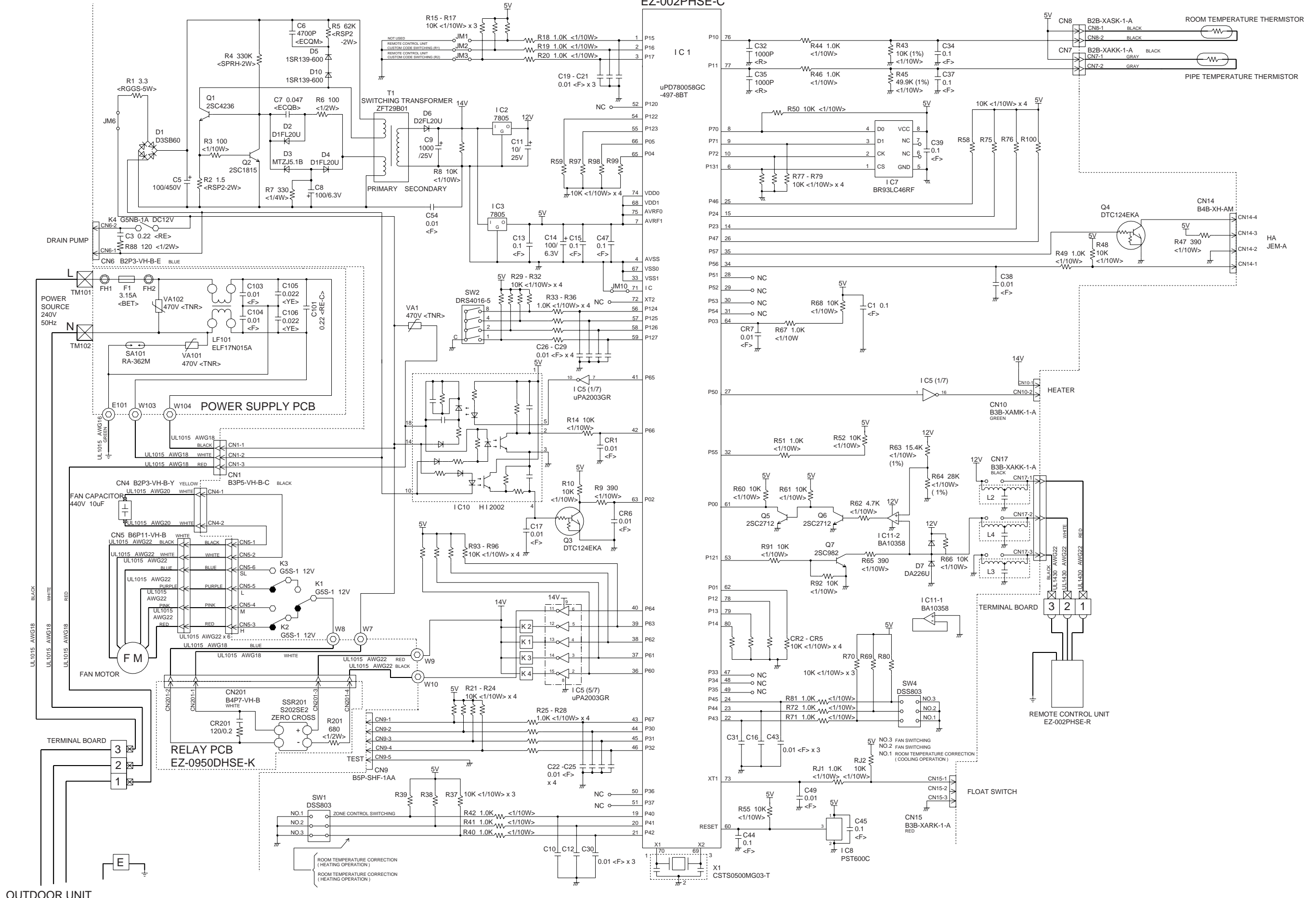

OUTDOOR PRINTED CIRCUIT BOARD CIRCUIT DIAGRAM

Model : RO-45HB

CONTROLLER PCB ASSEMBLY (MAIN PCB) EZ-002HHUE-C

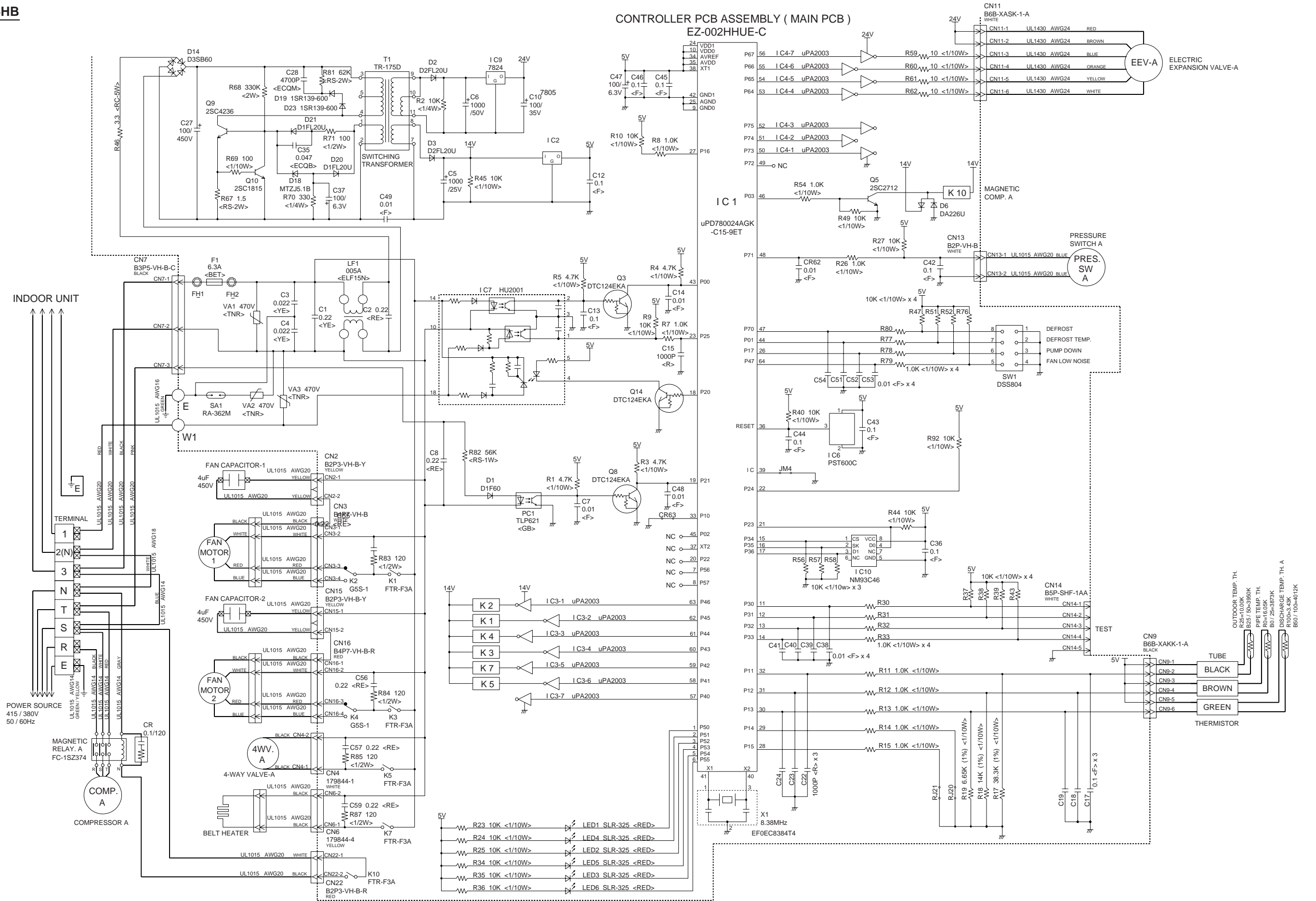

Model : RO-45CB

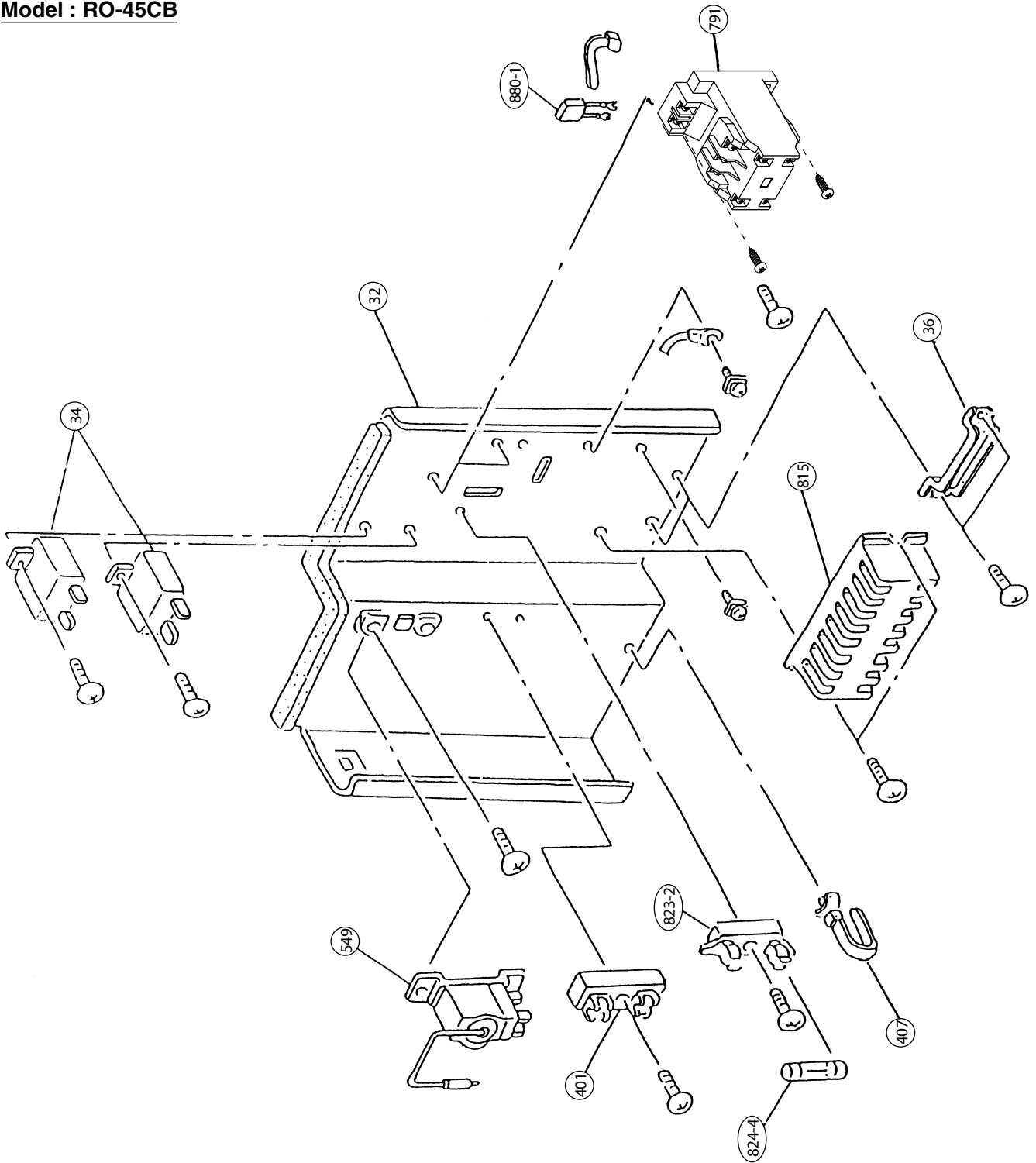

Model : RO-45HB

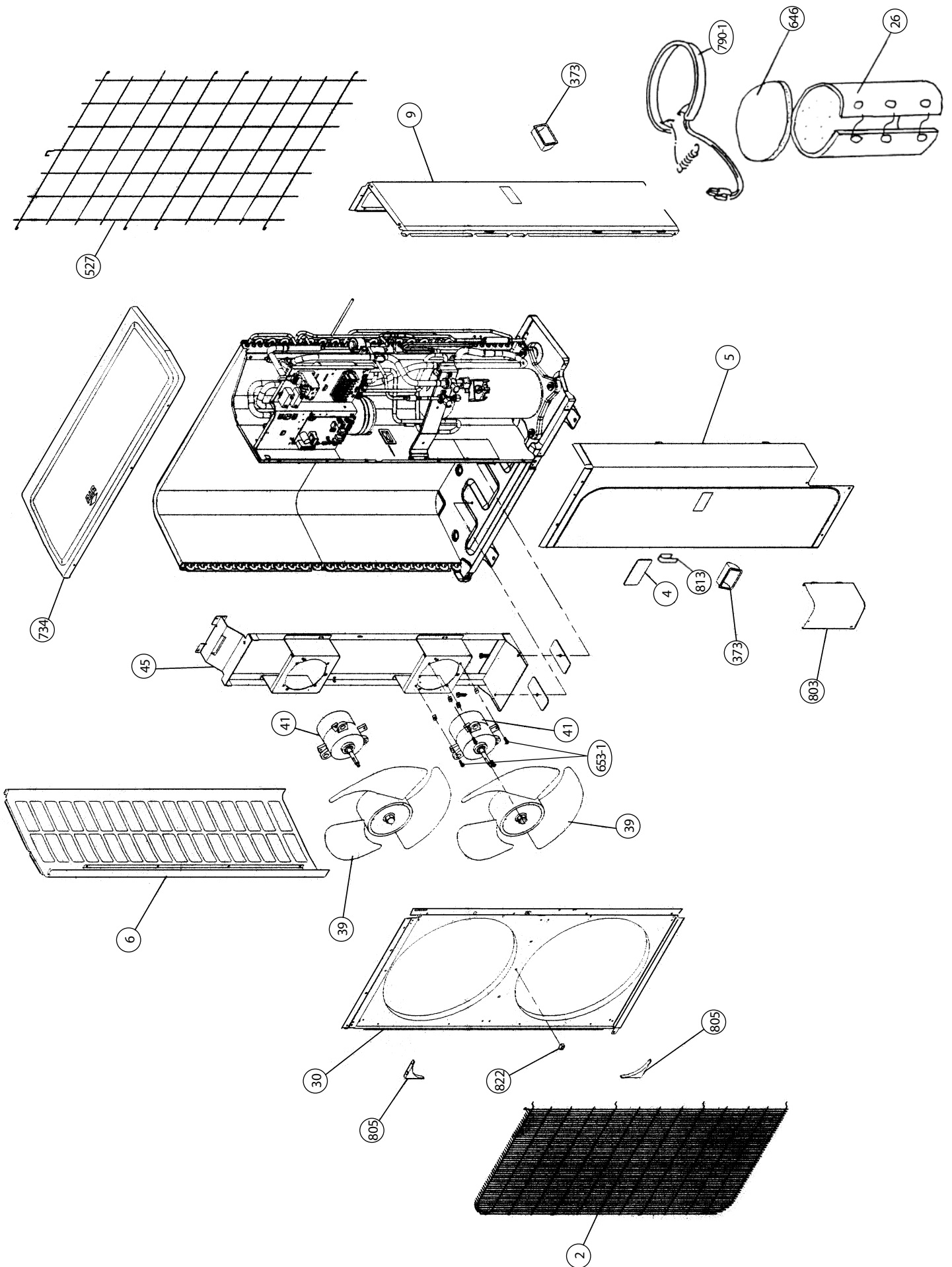

Model : RO-45HB

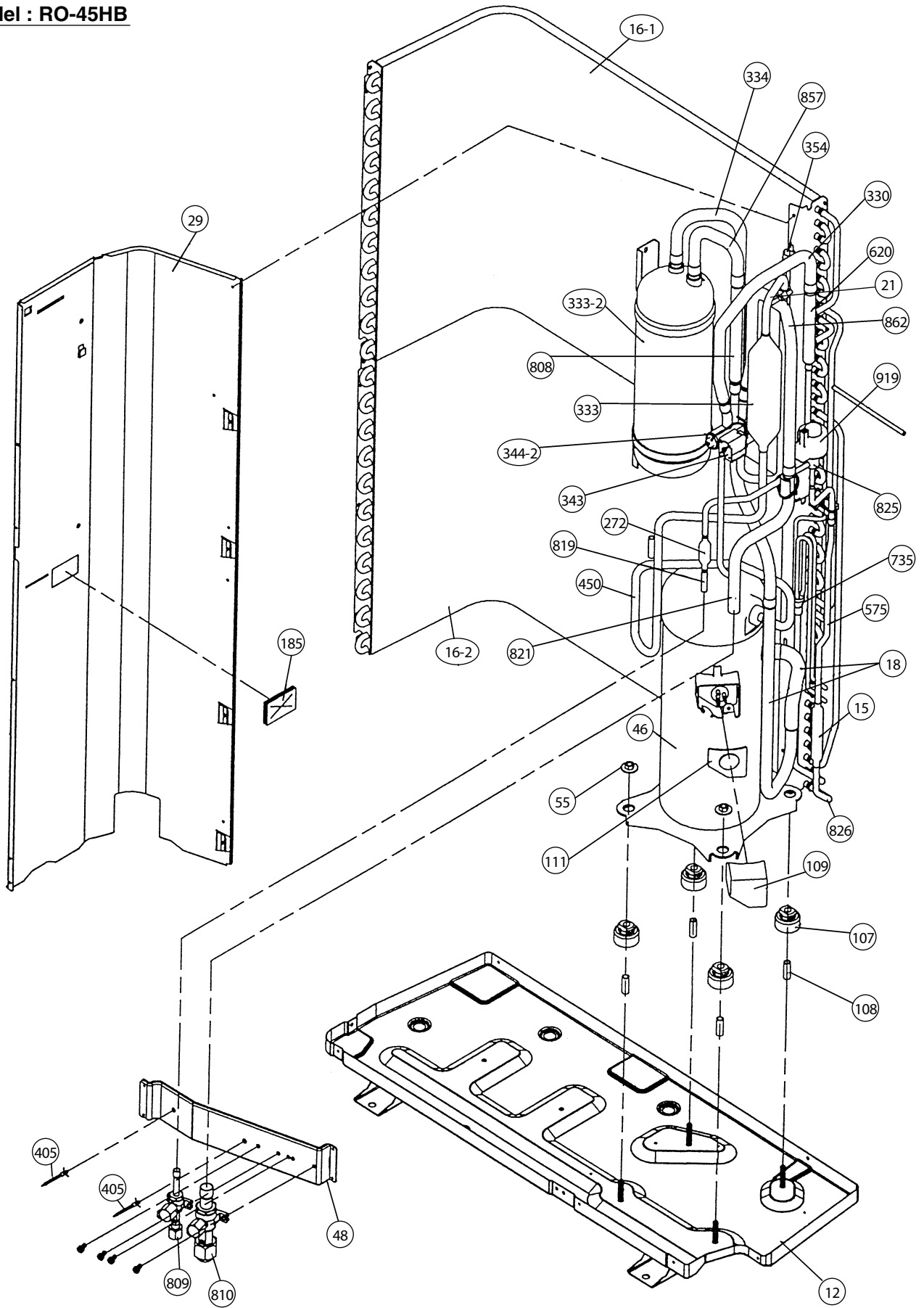

Model : RO-45HB

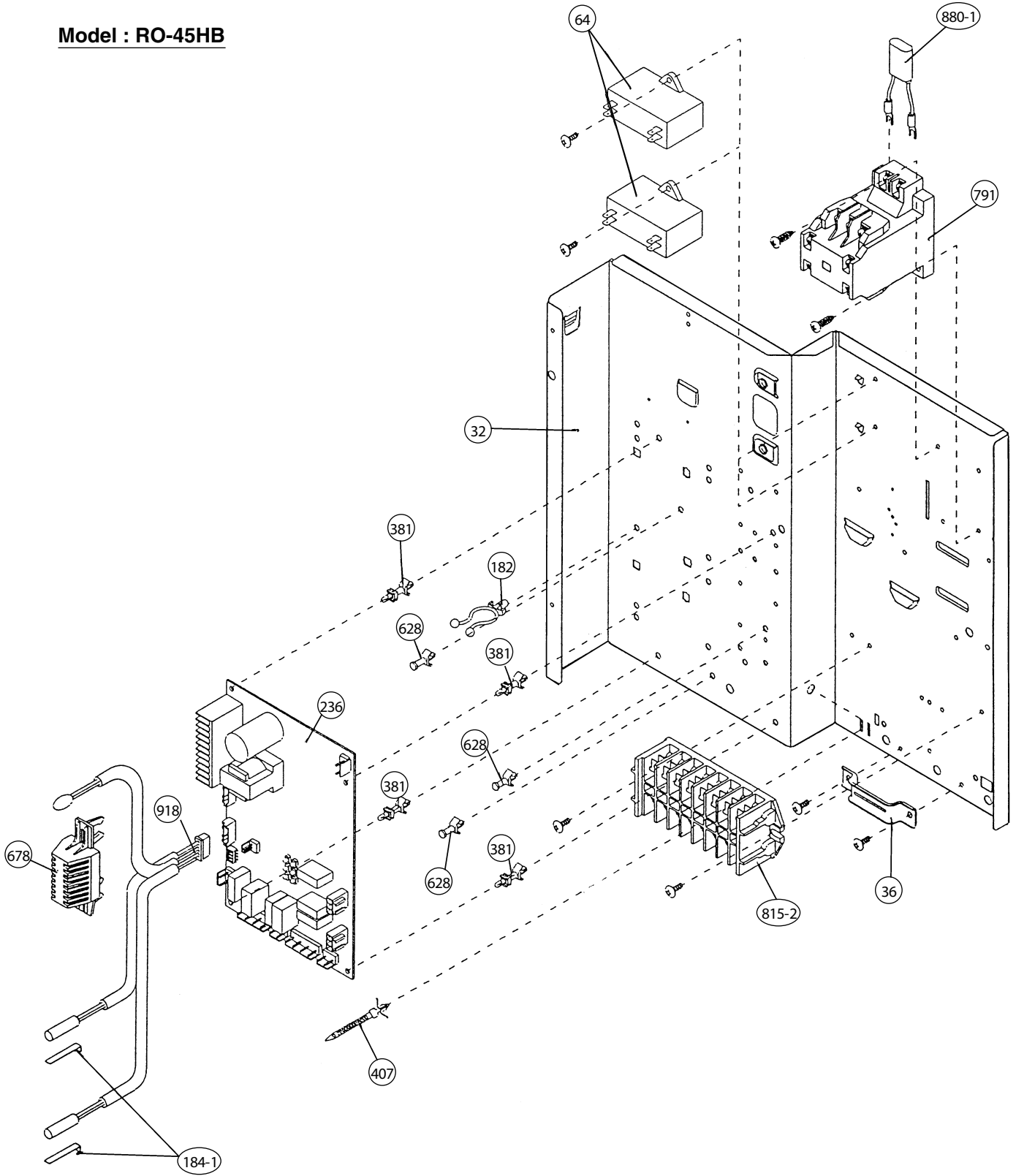

Models : RD-45CA
RD-45HA

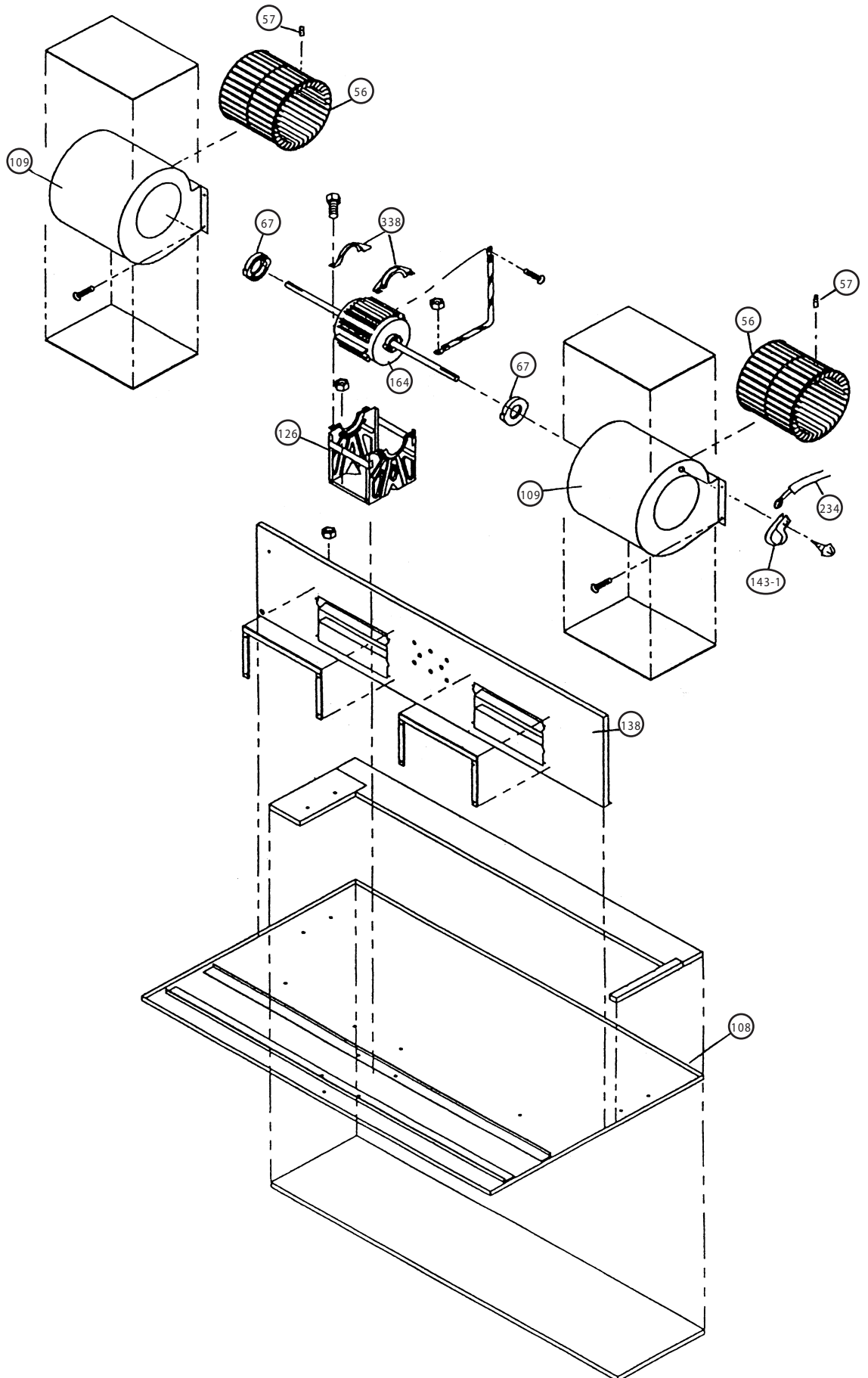

Models : RD-45CA
RD-45HA

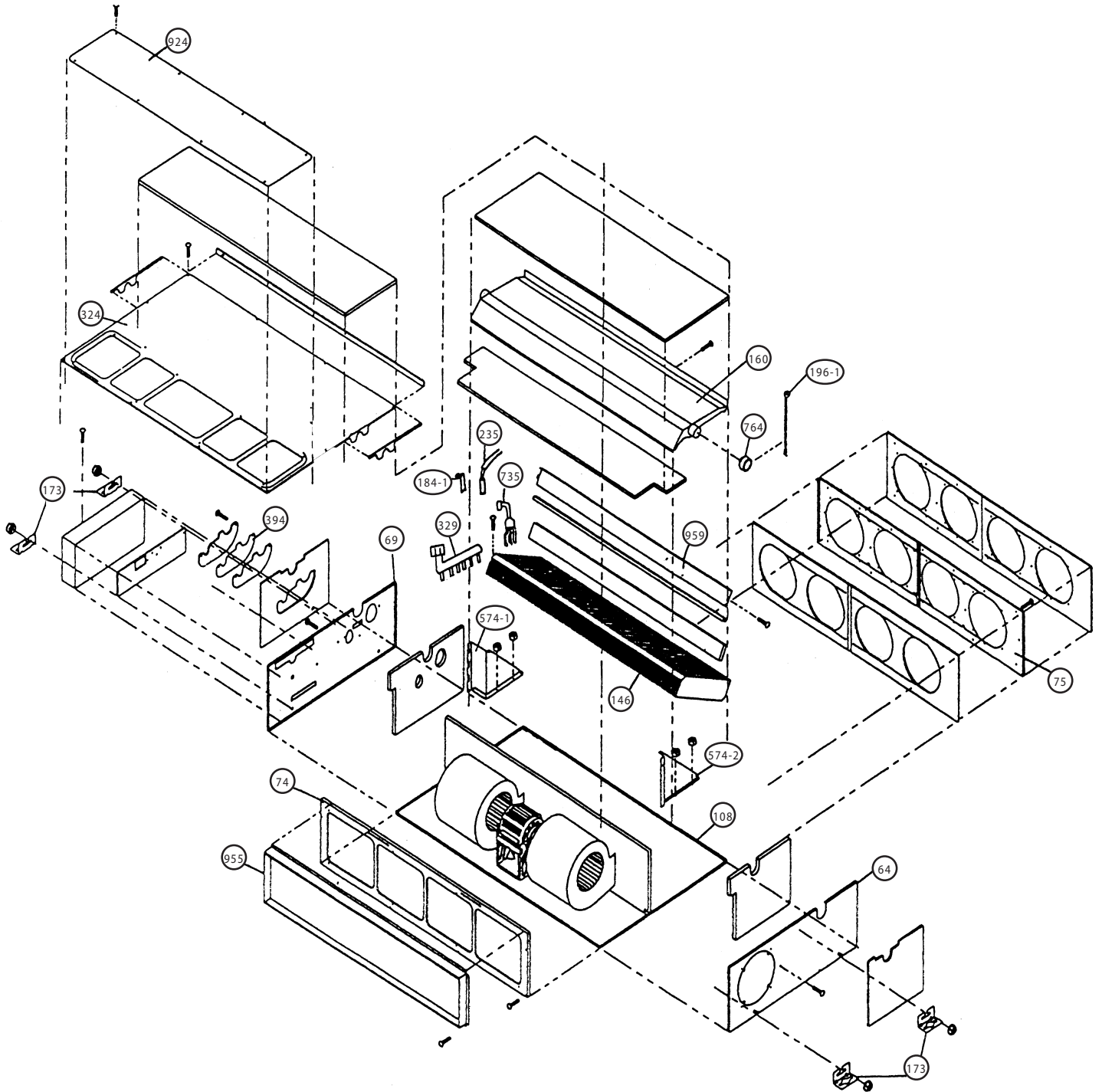

Models : RD-45CA
RD-45HA

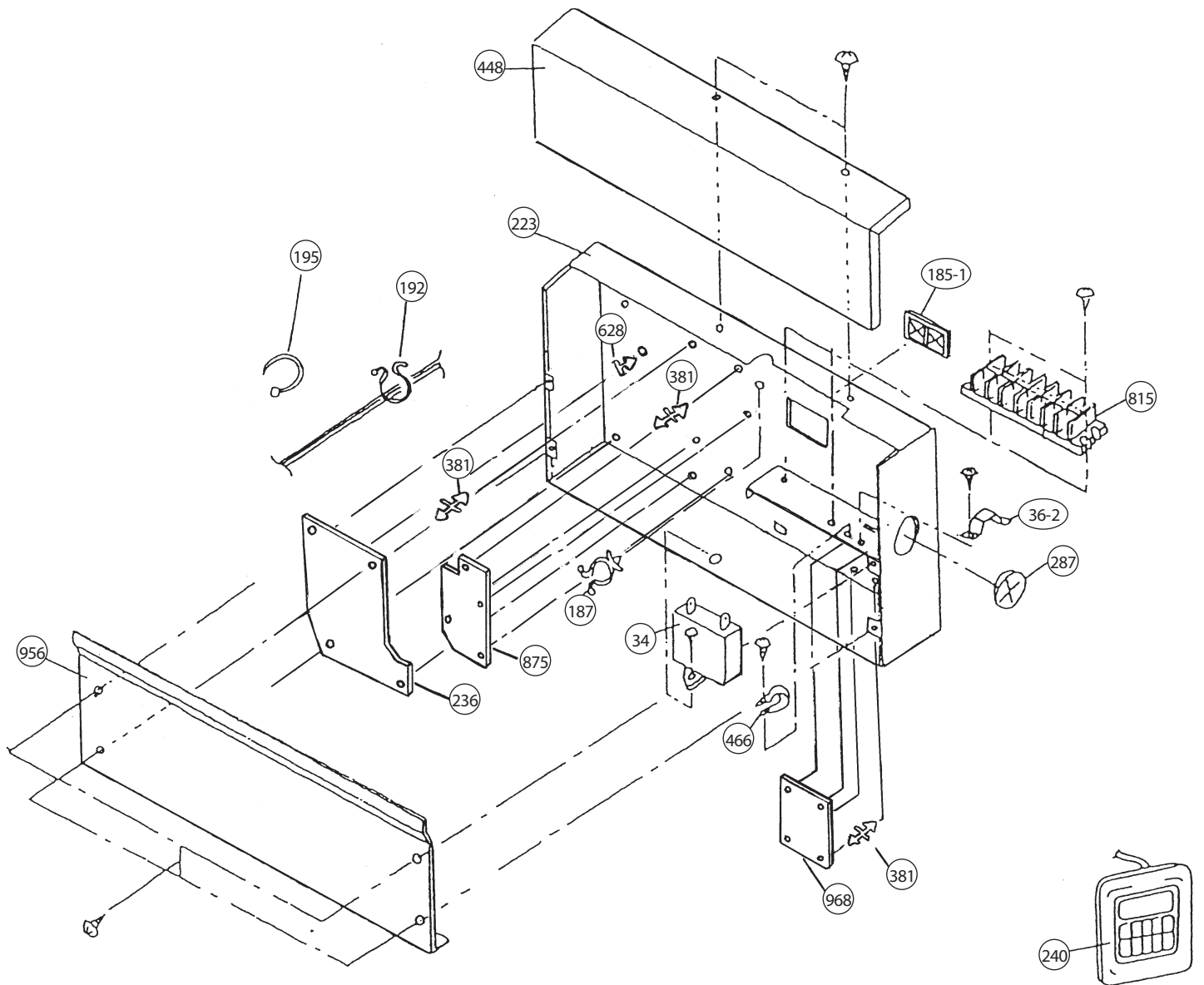

PARTS LIST

When you order parts, please make a photocopy of this page and fill the number of the parts in the "Order" column.

INDOOR UNIT

Ref. No.	Description	Part No.		Ord. Qty	Ref. No.	Description	Part No.		Ord. Qty
		RD-45CA	RD-45HA				RD-45CA	RD-45HA	
34	Capacitor (Fan Motor)	9700468042	9700468042		234	Thermistor Assy-Room	9703299056	9703299056	
36-2	Cord Holder Metal	9356362008	9356362008		235	Thermistor Assy-Pipe	9703297045	9703297045	
56	Sirocco Fan Assy	9356531022	9356531022		236	Controller PCB Assy	9704557056	9704557049	
57	Hex. Socket Screw	313616213202	313616213202		240	Remote Control Unit	9703173066	9371438030	
64	Cabinet-Left Metal	9356551006	9356551006		287	Cap (Power)	9352173011	9352173011	
67	Rubber (Vibration-proof)	313659068604	313659068604		324	Top Plate	9356546002	9356546002	
69	Cabinet-Right Metal	9356547009	9356547009		329	Coupling Pipe Assy	9357005003	9357005003	
74	Intake Panel	9356537000	9356537000		338	Motor Fixture	9356536003	9356536003	
75	Outlet Panel Assy	9356538007	9356538007		381	Locking Spacer	313209391506	313209391506	
108	Base Assy	9356518009	9356518009		394	Pipe Fixing Plate	9356554007	9356554007	
109	Casing Assy	9356527001	9356527001		448	Control Box Metal-B	9356560008	9356560008	
126	Motor Fixing Table Assy	9356533002	9356533002		466	Clamp NK-4N	313714328805	313714328805	
138	Separate Wall	9356523003	9356523003		574-1	Eva. Fixing Plate-R	9356521009	9356521009	
143-1	Clamp NK-3N	313361274700	313361274700		574-2	Eva. Fixing Plate-L	9356522006	9356522006	
146	Evaporator Assy	9356524017	9356524017		628	Locking Spacer	313005446558	313005446558	
160	Drain Pan Assy	9356542028	9356542028		735	Distributor Assy	9357004006	9357004006	
164	Fan Motor Assy-IN	9600830017	9600830017		764	Drain Cap	9356541007	9356541007	
173	Hanger Bracket	9356563009	9356563009		815	Terminal-7P	9703403019	9703403019	
184-1	Thermo. Spring-A	313728262708	313728262708		875	Filter PCB Assy	9704511053	9704561046	
185-1	Rubber Bushing	9357376004	9357376004		924	Intake Seal Plate	9356553000	9356553000	
187	Clamp No.1219	313361271706	313361271706		955	Square Flange Assy	9356555004	9356555004	
192	Clamp No.062	313361271402	313361271402		956	Control Box Metal-E	9356900002	9356900002	
195	Clamp SKB-100	313361275805	313361275805		959	Eva. Seal Plate	9356540000	9356540000	
196-1	Clamp SKB-3M	312300787605	312300787605		968	Relay PCB Assy	9701594030	9701594030	
223	Control Box Metal Assy	9356558005	9356558005						

OUTDOOR UNIT

When you order parts, please make a photocopy of this page and fill the number of the parts in the "Order" column.

Ref. No.	Description	Part No.	Ord. Qty	Ref. No.	Description	Part No.	Ord. Qty
		RO-45CB				RO-45CB	
2	Fan Cover	9352159015		373	Grip	9352157004	
4	Emblem-Rear	9361328006		401	Terminal-2P	9701971015	
5	Cabinet-A, Painted	9352146015		405	Clamp No.1763	313816345304	
6	Cabinet-C, Painted	9352149016		407	Clamp (Cable) No.1259	313739340109	
9	Cabinet-B, Painted	9352147012		420	Capillary Assy	9371224084	
12	Base Assy, Painted	9352136016		450	Discharge Pipe-A	9370951097	
15	Dryer	9368111014		527	Protection Net	9352163012	
16-1	Condenser-A Assy	9369544002		549	Thermistor-Outdoor	9352426001	
16-2	Condenser-B Assy	9369545009		575	Condensing Pipe-C	9372225011	
18	Suction Pipe Assy	9372226018		620	Inlet Pipe (Cond.) Assy	9372224014	
20	Discharge Pipe Assy	9370950052		646	Compressor Cover-B	9370774047	
26	Compressor Cover-A	9370774030		653-1	Bolt (Fan Motor Fixing)	9385089020	
29	Separate Wall	9355277013		734	Cabinet Top Plate	9352161018	
30	Blower Cover, Painted	9352151019		735	Distributor Assy	9372230015	
32	Control Box Metal	9352134012		772	Joint Pipe (Valve-A)	9370739039	
34	Capacitor (Fan Motor)	9357965024		788	Thermistor-Overheat	9354061002	
36	Cord Holder Metal	9356934007		790-1	Belt Heater-A	9361140042	
39	Propeller Fan Assy	9366378013		791	Magnetic Relay	9900078010	
41	Fan Motor Assy-Out	9600832028		803	Cabinet-D, Painted	9352150012	
45	Bracket (Motor) Assy	9368108007		805	Blower Cover Corner	9352160011	
46	Compressor Assy	9371396026		808	Inlet Pipe (Accumulator)	9352285004	
48	Bracket (Coupler) Assy	9355281010		809	Ball Valve-A	9371799049	
55	Special Nut M8 (For Comp.)	9355091008		810	Ball Valve-B	9371799056	
107	Rubber Seat-A (For Comp.)	9364084008		813	Cabinet Hook	9352148002	
108	Sleeve-A (For Comp.)	9364085005		815	Terminal-8P	9363276022	
109	Terminal Cover (For Comp.)	9364087009		817	Thermostat Fixture	9352164019	
111	Terminal packing	9364086002		819	Valve-A Coupl. Pipe	9370739039	
185	Rubber Bushing	313005066051		821	Joint Pipe (Valve-B)	9352284007	
300	Suction Pipe-C	9372227015		822	Fan Cover Fixture-A	9352158018	
333-2	Accumulator (B)	9371615011		823-2	Fuse Holder	0500063024	
				824-4	Fuse	0600222529	
				826	Condensing Pipe-B	9372231012	
				880-1	Network	9700987017	











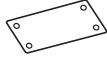

OUTDOOR UNIT

When you order parts, please make a photocopy of this page and fill the number of the parts in the "Order" column.



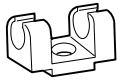

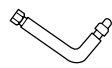





Ref. No.	Description	Part No.	Ord.	Ref. No.	Description	Part No.	Ord.
		RO-45HB	Q'ty			RO-45HB	Q'ty
2	Fan Cover	9352159015		381	Locking Spacer	313209391506	
4	Emblem-Rear	9361328006		405	Clamp No.1763	313816345304	
5	Cabinet-A, Painted	9352146015		407	Clamp (Cable) No.1259	313739340109	
6	Cabinet-C, Painted	9352149016		450	Discharge Pipe-A	9372229019	
9	Cabinet-B, Painted	9352147012		527	Protection Net	9352163012	
12	Base Assy, Painted	9352136016		575	Condensing Pipe-C	9372225011	
15	Dryer	9368111014		620	Inlet Pipe (Cond.) Assy	9372224014	
16-1	Condenser-A Assy	9355338011		628	Locking Spacer	313005446558	
16-2	Condenser-B Assy	9353363008		646	Compressor Cover-B	9370774047	
18	Suction Pipe Assy	9372226018		653-1	Bolt (Fan Motor Fixing)	9385089020	
21	Discharge Pipe-B	9372246016		678	Bracket (Thermistor)	313557406106	
26	Compressor Cover-A	9370774030		734	Cabinet Top Plate	9352161018	
29	Separate Wall Assy	9355277013		735	Distributor Assy	9372230015	
30	Blower Cover, Painted	9352151019		790-1	Belt Heater-A	9361140042	
32	Control Box Metal	9352134012		791	Magnetic Relay	9900078010	
36	Cord Holder Metal	9356934007		803	Cabinet-D, Painted	9352150012	
39	Propeller Fan Assy	9366378013		805	Blower Cover Corner	9352160011	
41	Fan Motor Assy-Out	9600832028		808	Inlet Pipe (Accumulator)-A	9372244012	
45	Bracket (Motor) Assy	9368108007		809	Ball Valve-A	9371799049	
46	Compressor Assy	9371396026		810	Ball Valve-B	9371799056	
48	Bracket (Coupler) Assy	9355281010		813	Cabinet Hook	9352148002	
55	Special Nut M8 (For Comp.)	9355091008		815-2	Terminal 8P	9363276022	
64	Capacitor (Fan Motor)	9357965024		819	Valve-A Coupl. Pipe	9363457001	
107	Rubber Seat-A (For Comp.)	9364084008		821	Joint Pipe (Valve-B)	9352284007	
108	Sleeve-A (For Comp.)	9364085005		822	Fan Cover Fixture-A	9352158018	
109	Terminal Cover (For Comp.)	9364087009		825	Expansion Valve	9900170028	
111	Terminal Packing	9364086002		826	Condensing Pipe-B	9372231012	
182	Clamp No.249	313361271505		857	Inlet Pipe (Accumulator)-B	9372244036	
184-1	Thermo. Spring-A	313728262708		862	Valve-B Coupl. Pipe	9372243015	
185	Rubber Bushing	313005066051		880-1	Network	9700987017	
236	Controller PCB Assy	9704764096		918	Thermistor Assy	9900129019	
272	Strainer Assy	9354139008		919	Expansion Valve Coil	9900172015	
330	Inlet Pipe (Cond.)-A	9372239018					
333	Accumulator	9350363018					
333-2	Accumulator Assy (B)	9371615011					
334	Suction Pipe-B	9372227015					
343	Solenoid Coil	9900165024					
344-2	4-Way Valve	9970035012					
354	Pressure Switch	9704045003					
373	Grip	9352157004					

STANDARD ACCESSORIES

INDOOR UNIT ACCESSORIES

Name and Shape	Q'ty	Application	Parts No.	
			RD-45CA	RD-45HA
Installation template 	1	For positioning the indoor unit	9357036007	9357036007
Hanger 	4	For suspending the indoor unit from ceiling	9356563009	9356563009
Special nut A (large flange) 	4	For suspending the indoor unit from ceiling	313005446653	313005446653
Special nut B (small flange) 	4		313005446759	313005446759
Coupler heat insulation (large) 	2	For indoor side pipe joint (large pipe)	9350716029	9350716029
Coupler heat insulation (small) 	1	For indoor side pipe joint (small pipe)	9352766015	9352766015
Nylon fastener 	1	For fixing the drain hose	312300787605	312300787605
Remote control unit 	1		9703173066	9371438030
Remote control unit cord clamp 	10	For installing the remote controller cord	313714181904	313714181904
Tapping screw (flush heads) 	10	For installing the remote control unit cord clamp	301141153027	301141153027
Auxiliary pipe assembly 	1	For wiring conduit (gas side) connection	9357038001	9357038001
Drain hose insulation 	1	Insulates the drain hose and vinyl hose connection	313806217708	313806217708

OUTDOOR UNIT ACCESSORIES

Name and Shape	Q'ty	Application	Parts No.	
			RO-45CB	RO-45HB
Power cap 	1	For power cord installation	9352173011	9352173011
Auxiliary pipe assembly 	1	For wiring conduit (gas side) connection (May not be supplied, depending on the model)	9355292016	9355292016
Edge cover 	1	For wiring conduit installation hole edge protection	9352436000	9352436000
Tapping screw 	2	<ul style="list-style-type: none"> • For cabinet A and cabinet D mounting (1) • Spare (1) 	301463040100	301463040100
Binder 	1	For power cord binding	313035356905	313035356905
Putty 	1	For sealing	303020200114	303020200114
Coupler heat insulation 	1	For outdoor side pipe joint	313005074759	313005074759
Pipe (drain) 	2	For outdoor unit drain piping work	313728031005	_____
Flexible tube 	2		313013042915	_____
Cap (drain) 	2		313166024302	_____

