

# FUJII ELECTRIC

## SPLIT TYPE AIR CONDITIONER (50Hz)

## DUCT type

# SERVICE MANUAL

Models Indoor unit Outdoor unit

RD-18HA ———— ROD-18HA  
RD-18HAH ————

### C O N T E N T S

SPECIFICATIONS .....	1
OUTLINE AND DIMENSIONS .....	2
CIRCUIT DIAGRAM .....	3
REFRIGERANT SYSTEM DIAGRAM .....	4
ERROR CONTENTS .....	5
INDOOR PRINTED CIRCUIT BOARD CIRCUIT DIAGRAM .....	6
OUTDOOR PRINTED CIRCUIT BOARD CIRCUIT DIAGRAM .....	7
DISASSEMBLY ILLUSTRATION .....	8
PARTS LIST .....	14

# S P E C I F I C A T I O N S

INDOOR UNIT		RD-18HA, RD-18HAH
OUTDOOR UNIT		ROD-18HA
COOLING CAPACITY	(kW)	5.20 - 5.30
HEATING CAPACITY	(kW)	5.60 - 5.70

## ELECTRICAL DATA

POWER SOURCE	(V)		220 - 240
FREQUENCY	(Hz)		50
RUNNING CURRENT	(A)	COOLING	9.8 - 10.0
		HEATING	9.0 - 9.2
INPUT WATTS	(kW)	COOLING	2.10 - 2.20
		HEATING	1.90 - 2.00
E.E.R.	(kW/kW)	COOLING	2.48 - 2.41
		HEATING	2.95 - 2.85
MOISTURE REMOVAL	(ℓ/hr)		1.6
AIR CIRCULATION-Hi	(m <sup>3</sup> /hr)		750

## COMPRESSOR

TYPE	Hermetic type, Permanent split condenser, 2 pole, Single phase, Induction motor
CODE	2JS350D5BB02

## FAN MOTOR

TYPE		RD-18HA	RD-18HAH	ROD-18HA
		MFA-18HTT	MFA-18HZZ	MFB-25JTT
POWER SOURCE	(V)	220 - 240	220 - 240	220 - 240
HI-SPEED	(r.p.m.)	960	1,310	740
MED-SPEED	(r.p.m.)	900	1,220	—
LO-SPEED	(r.p.m.)	840	1,120	280

## DIMENSIONS

HEIGHT	(mm)	217	643
WIDTH	(mm)	953	840
DEPTH	(mm)	595	336

## WEIGHT

GROSS WEIGHT	(kg)	29	76
NET WEIGHT	(kg)	25	68

## REFRIGERANT CHARGE

PIPE LENGTH	7.5 m (25 ft)	10 m (33 ft)	15 m (49 ft)	20 m (66 ft)
FULL CHARGE AMOUNT	1,800g ( 63.5 oz.)	1,925g ( 67.9 oz.)	2,175g ( 76.7 oz.)	2,425g ( 85.5 oz.)

- Notes :
- Between 7.5 m and 20 m, when using a connection pipe other than that in the table, charge additional refrigerant with 50 g (1.8 oz.) / 1 m (3.3 ft) for Reverse cycle model, 17 g (0.6 oz.) / 1 m (3.3 ft) for cooling model as criteria.
  - The above list shows values at the external static pressure of 0 Pa for RD-18HA and 40 Pa for RD-18HAH.

# OUTLINE AND DIMENSIONS

## INDOOR UNIT

(unit : mm)

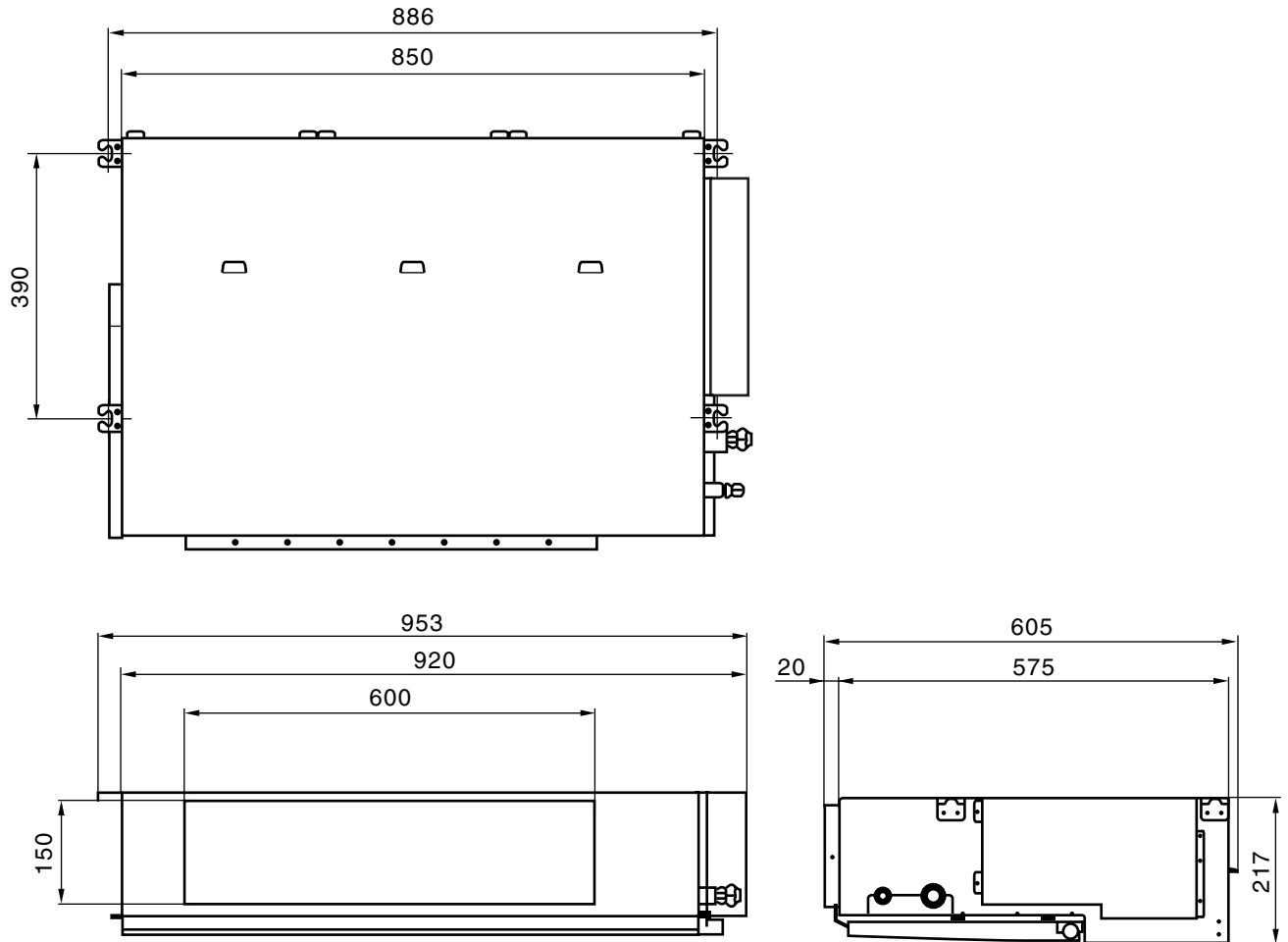

## OUTDOOR UNIT

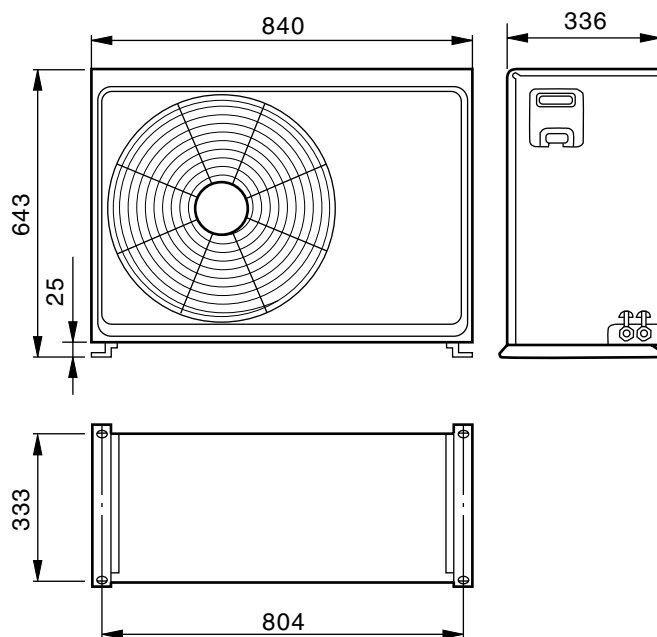

# CIRCUIT DIAGRAM

## INDOOR UNIT

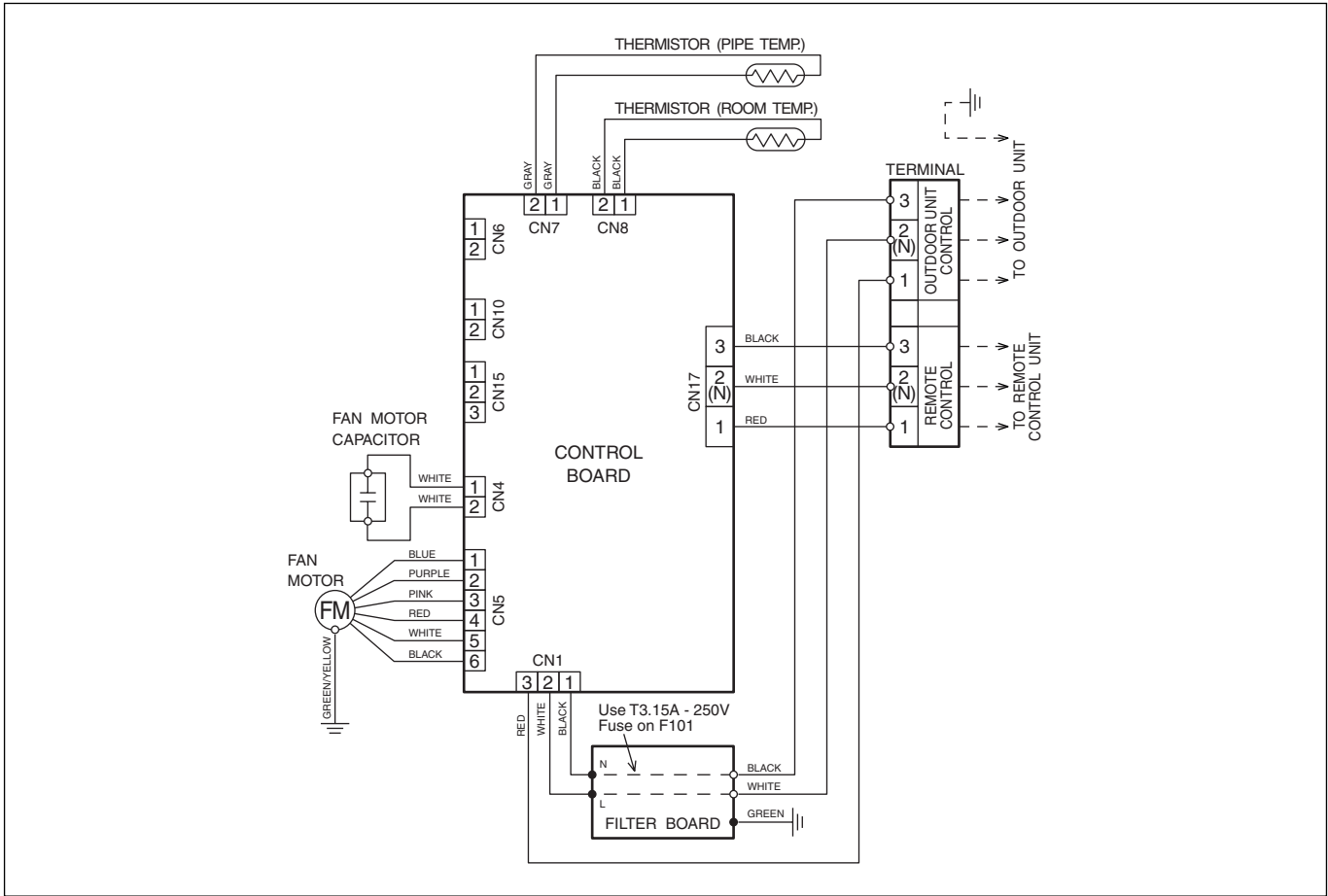

## OUTDOOR UNIT

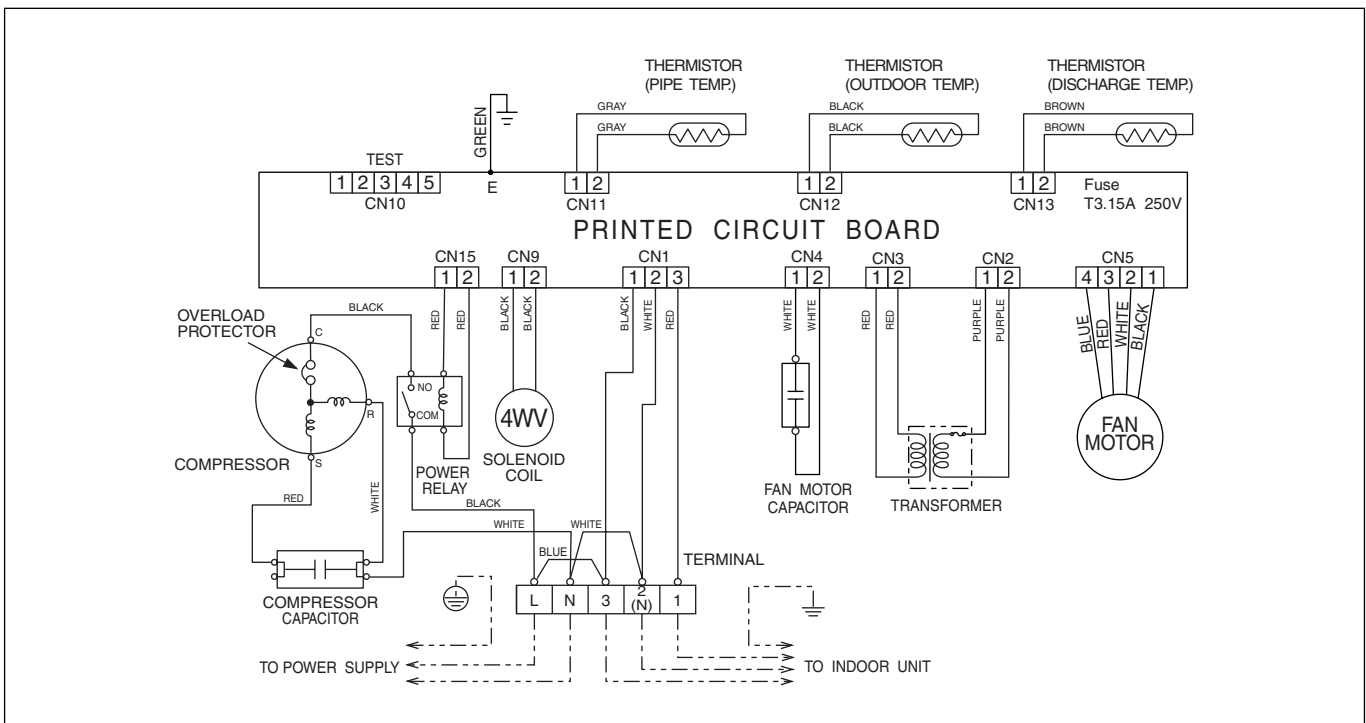

# REFRIGERANT SYSTEM DIAGRAM

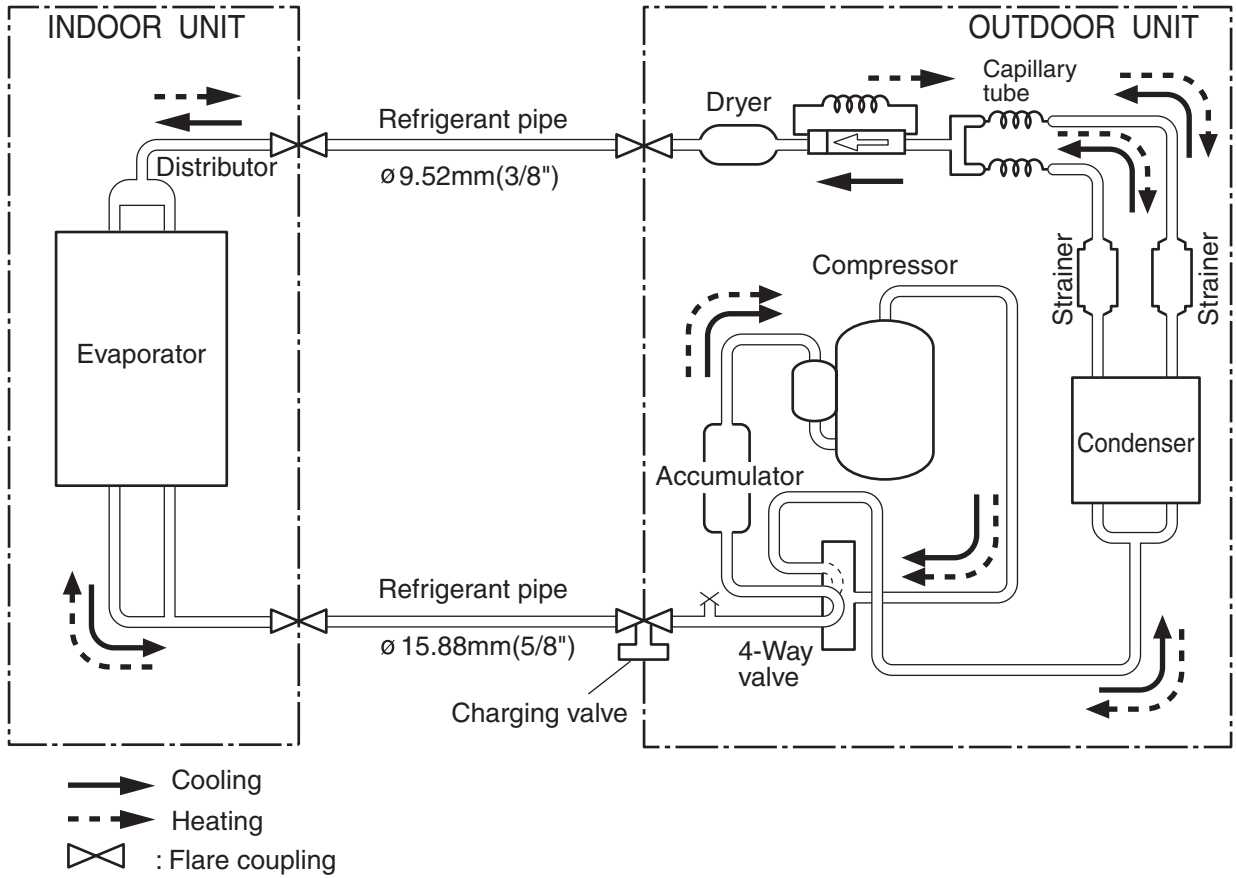

# ERROR CONTENTS

## 1. INDOOR UNIT

- When EE : EE blinks at the current time display, there is an error inside the air conditioner. If the SET TIME button (▼) and SET TEMP./DAY button (▼) are pressed simultaneously for more than three seconds, the self diagnosis check will start and the error contents will be displayed at the current time display. When the operation lamp lights, press the START/STOP button and after the operation lamp goes off, perform the same operation. Process the error contents by referring to (Table 1).

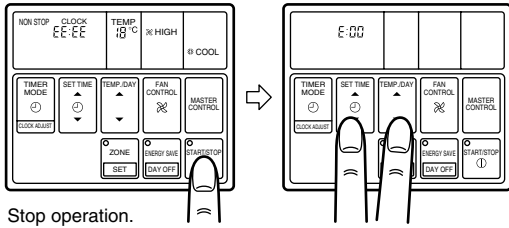

Table 1

Error code	Error contents
E:00	Communication error (indoor unit ↔ remote controller)
E:01	Communication error (indoor unit ↔ outdoor unit)
E:02	Room temperature sensor open
E:03	Room temperature sensor short-circuited
E:04	Indoor heat exchanger temperature sensor open
E:05	Indoor heat exchanger temperature sensor short-circuited
E:06	Outdoor heat exchanger temperature sensor open
E:07	Outdoor heat exchanger temperature sensor short-circuited
E:08	Power source connection error
E:09	Float switch operated
E:0A	Outdoor temperature sensor open
E:0B	Outdoor temperature sensor short-circuited
E:0C	Discharge pipe temperature sensor open
E:0D	Discharge pipe temperature sensor short-circuited
E:0E	Outdoor high pressure abnormal
E:0F	Discharge pipe temperature abnormal
E:11	Model abnormal
E:12	Indoor fan abnormal
E:13	Outdoor signal abnormal
E:14	Outdoor EEPROM abnormal

- To stop test running, press the START/STOP button.
- For the operation method, refer to the operating manual and perform operation check.
- Check that there are no abnormal sounds or vibration sounds during test running.

## 2. OUTDOOR UNIT

When the outdoor temperature drops, the outdoor unit's fans may switch to low speed, or one of the fans may stop intermittently.

### ERROR : Heat & Cool model (Reverse cycle) only

The LED lamps operate as follows (Table 2) according to the error contents.

Table 2

Error display		Error contents
LED 1	LED 2	
<p>ON OFF</p> <p>Quick flash continued</p>	<p>ON OFF</p> <p>Quick flash continued</p>	Model abnormal or EEPROM abnormal
<p>ON OFF</p> <p>1 quick flash repeated</p>	<p>ON OFF</p> <p>Lighting continued</p>	Power source connection error
<p>ON OFF</p> <p>2 quick flashes repeated</p>	<p>ON OFF</p> <p>Lighting continued</p>	Discharge temperature sensor error
<p>ON OFF</p> <p>3 quick flashes repeated</p>	<p>ON OFF</p> <p>Lighting continued</p>	Outdoor heat exchanger temperature sensor error
<p>ON OFF</p> <p>4 quick flashes repeated</p>	<p>ON OFF</p> <p>Lighting continued</p>	Outdoor temperature sensor error
<p>ON OFF</p> <p>5 quick flashes repeated</p>	<p>ON OFF</p> <p>Lighting continued</p>	Communication signal error
<p>ON OFF</p> <p>6 quick flashes repeated</p>	<p>ON OFF</p> <p>Lighting continued</p>	Indoor unit error
<p>ON OFF</p> <p>7 quick flashes repeated</p>	<p>ON OFF</p> <p>Lighting continued</p>	Discharge temperature abnormal
<p>ON OFF</p> <p>8 quick flashes repeated</p>	<p>ON OFF</p> <p>Lighting continued</p>	High pressure abnormal

When the fault is cleared, the LED lamp goes off.

However, for discharge pipe temperature abnormal and high pressure abnormal, the LED lamp lights continuously for 24 hours, as long as the power is not turned off.

# INDOOR PRINTED CIRCUIT BOARD CIRCUIT DIAGRAM

Models : RD-18HA  
RD-18HAH

## INDOOR PRINTED CIRCUIT BOARD CIRCUIT DIAGRAM

### CONTROLLER PCB ASSEMBLY ( MAIN PCB ) EZ-00225HSE-C

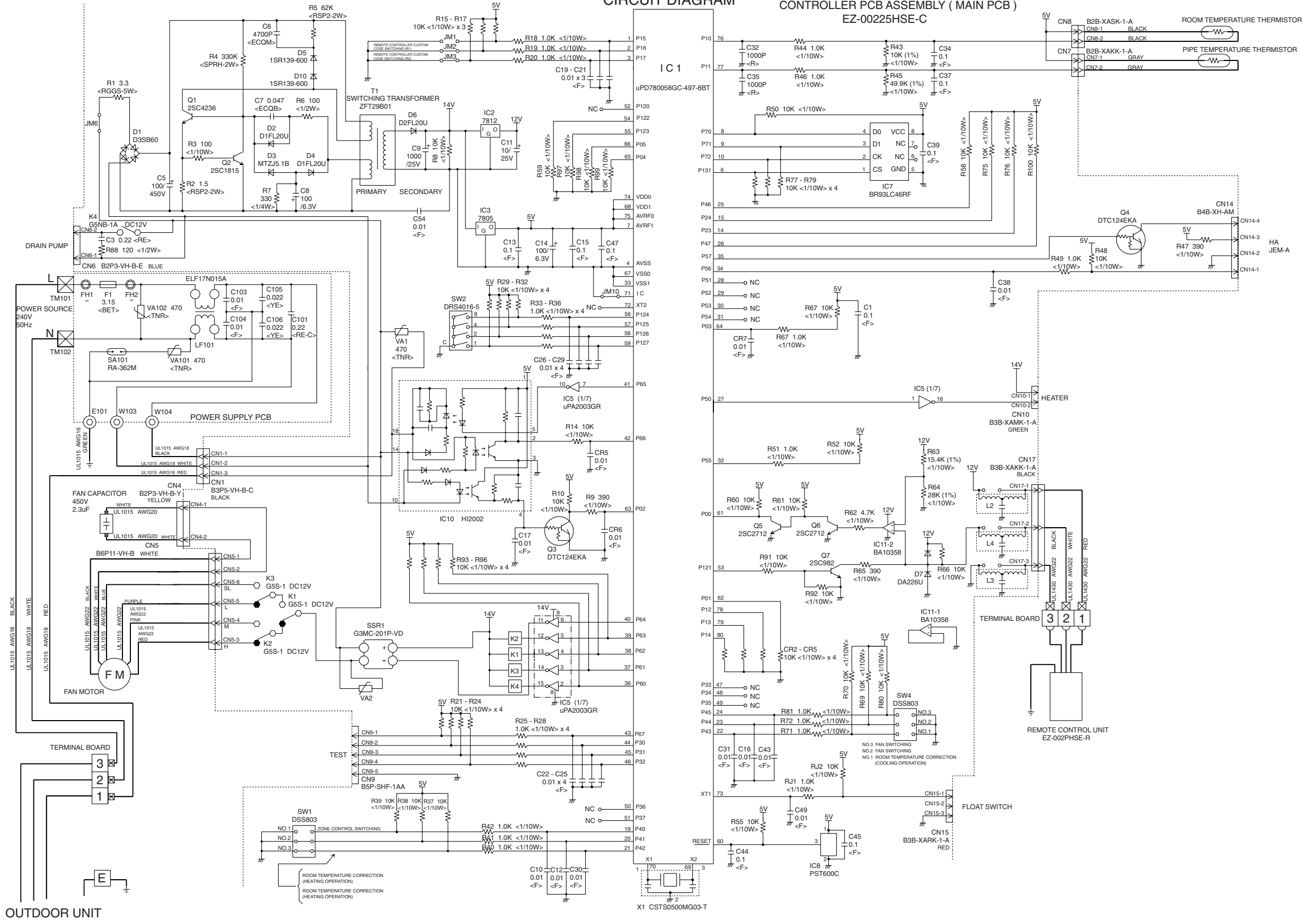

OUTDOOR UNIT

# OUTDOOR PRINTED CIRCUIT BOARD CIRCUIT DIAGRAM

Model : ROD-18HA

## OUTDOOR PRINTED CIRCUIT BOARD CIRCUIT DIAGRAM

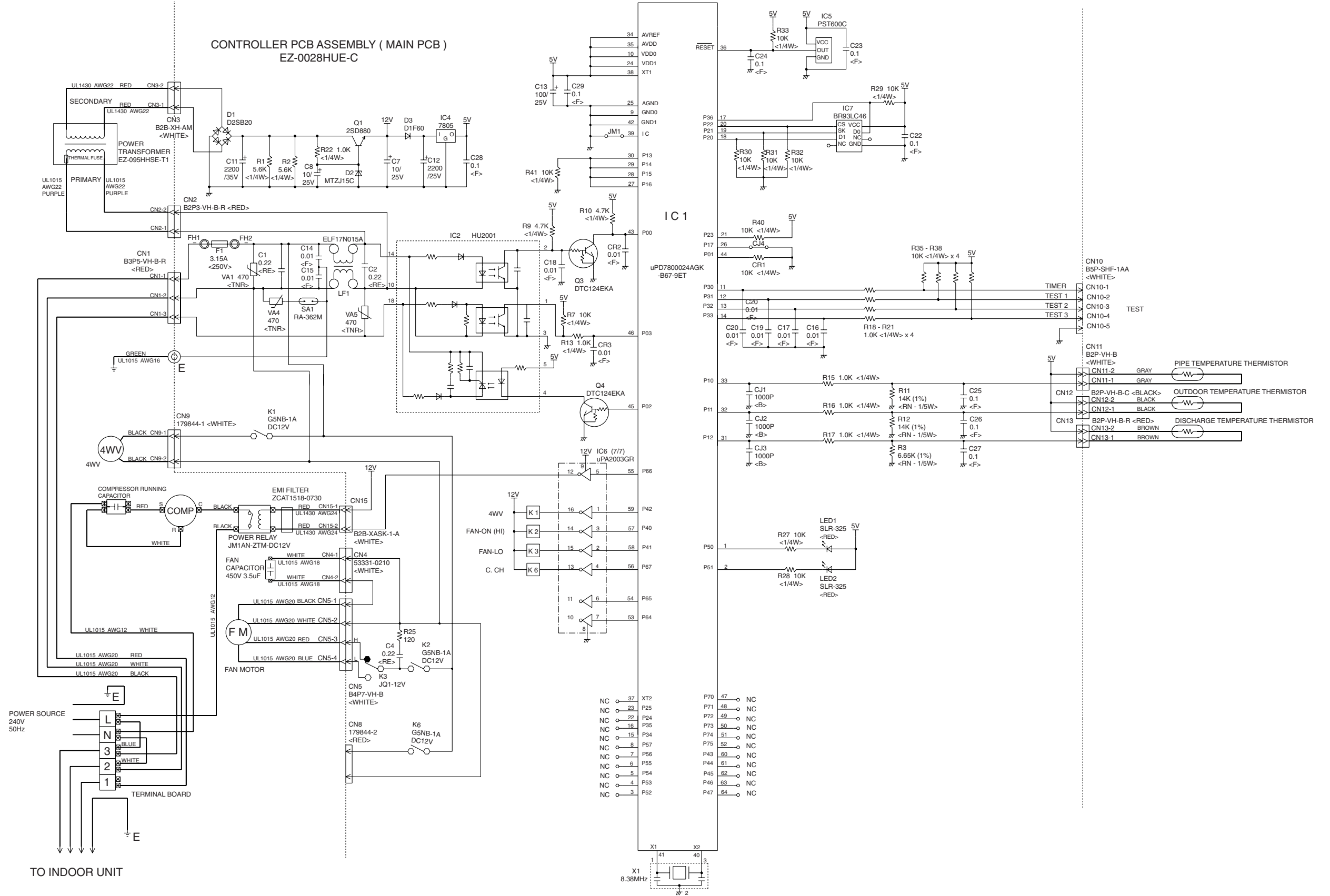



# DISASSEMBLY ILLUSTRATION

## OUTDOOR UNIT

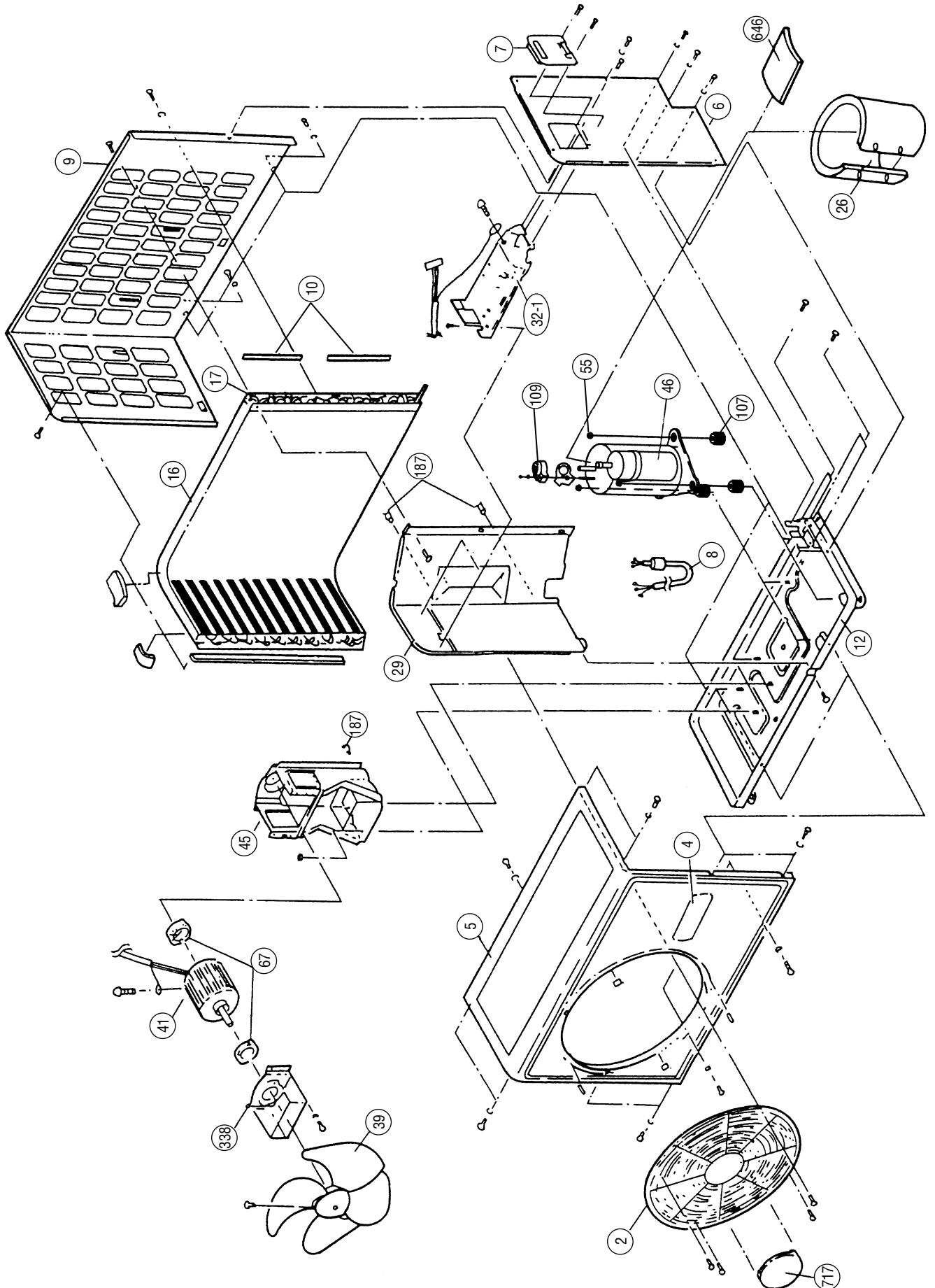

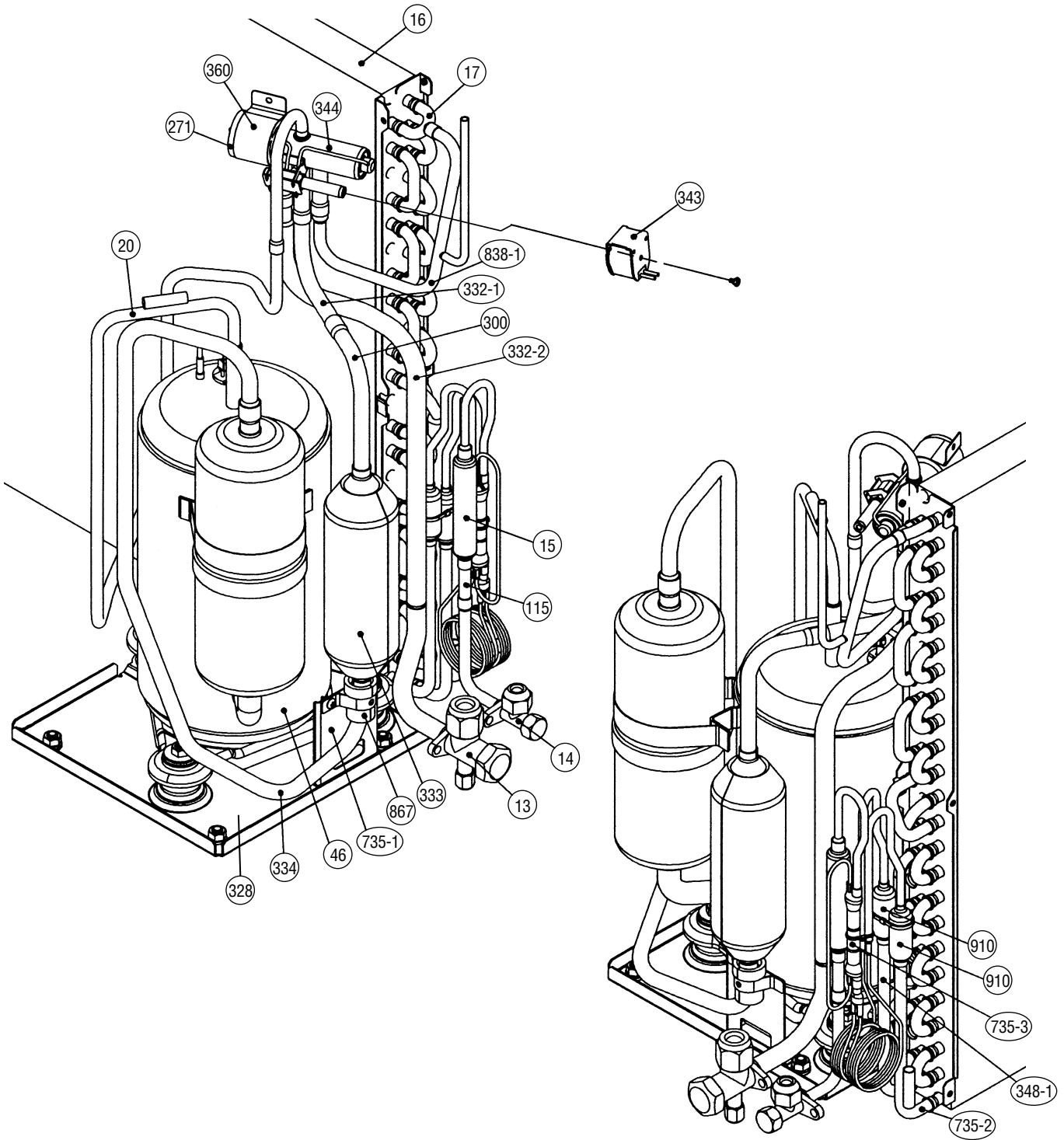

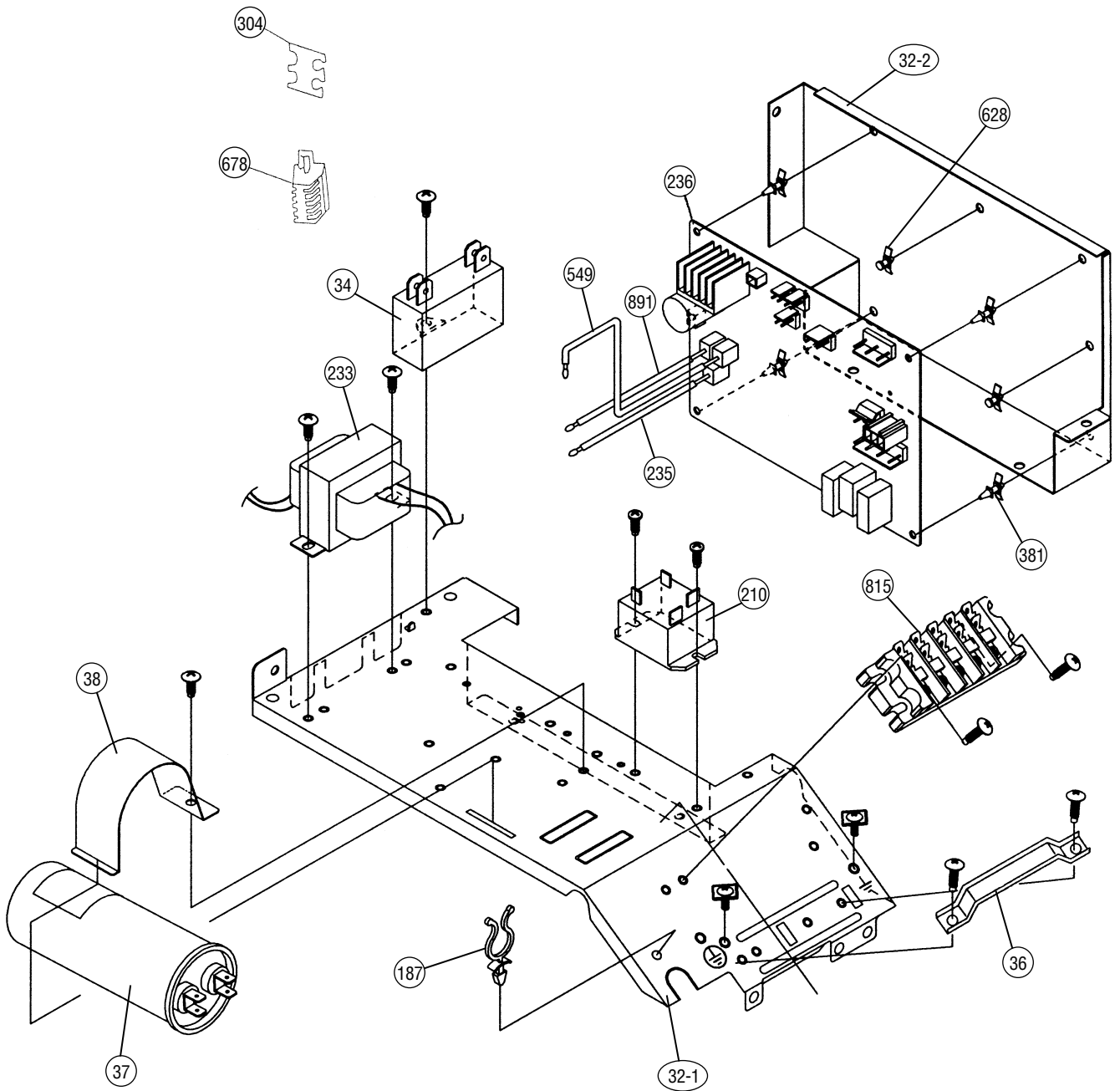

# INDOOR UNIT

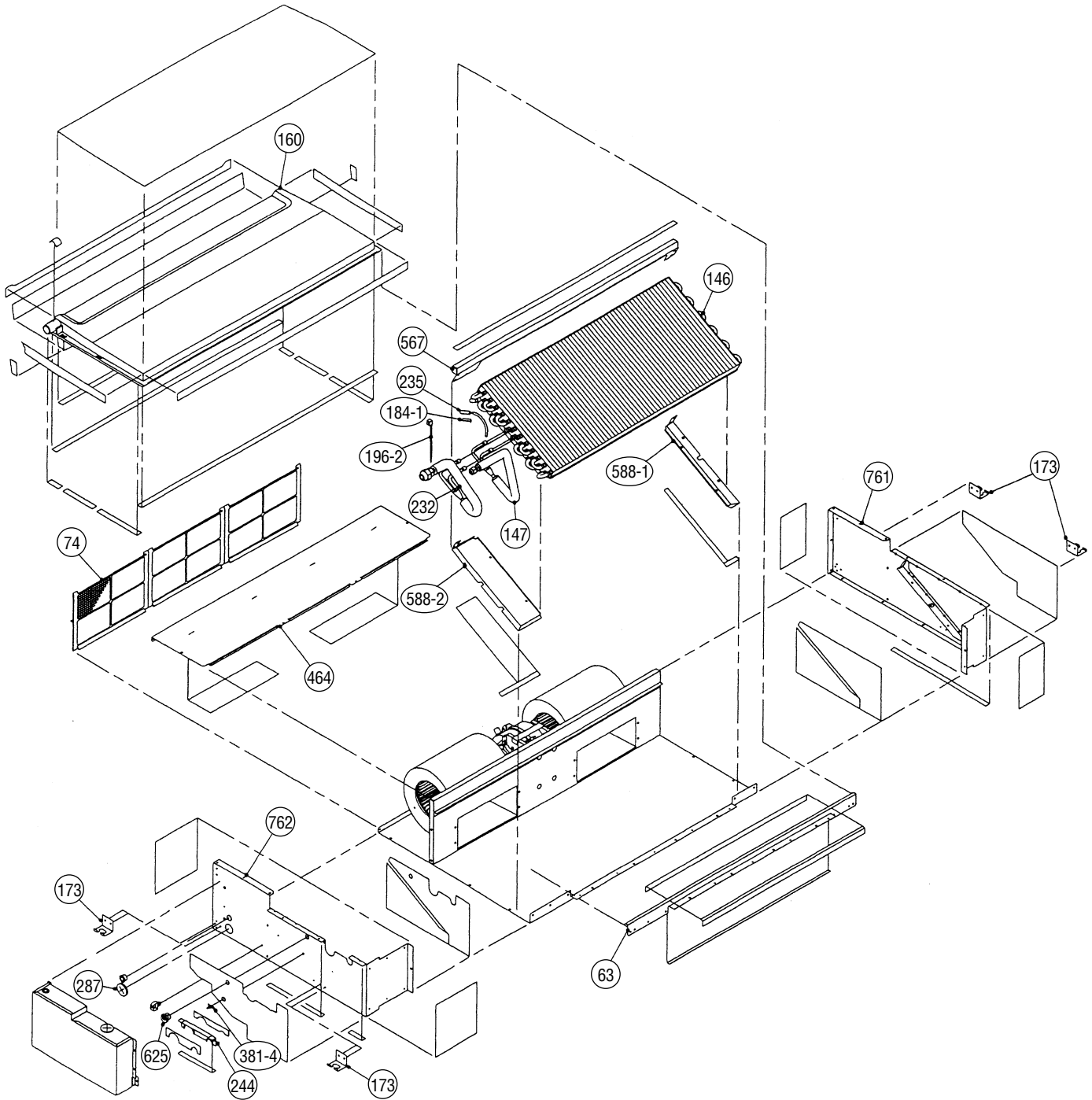

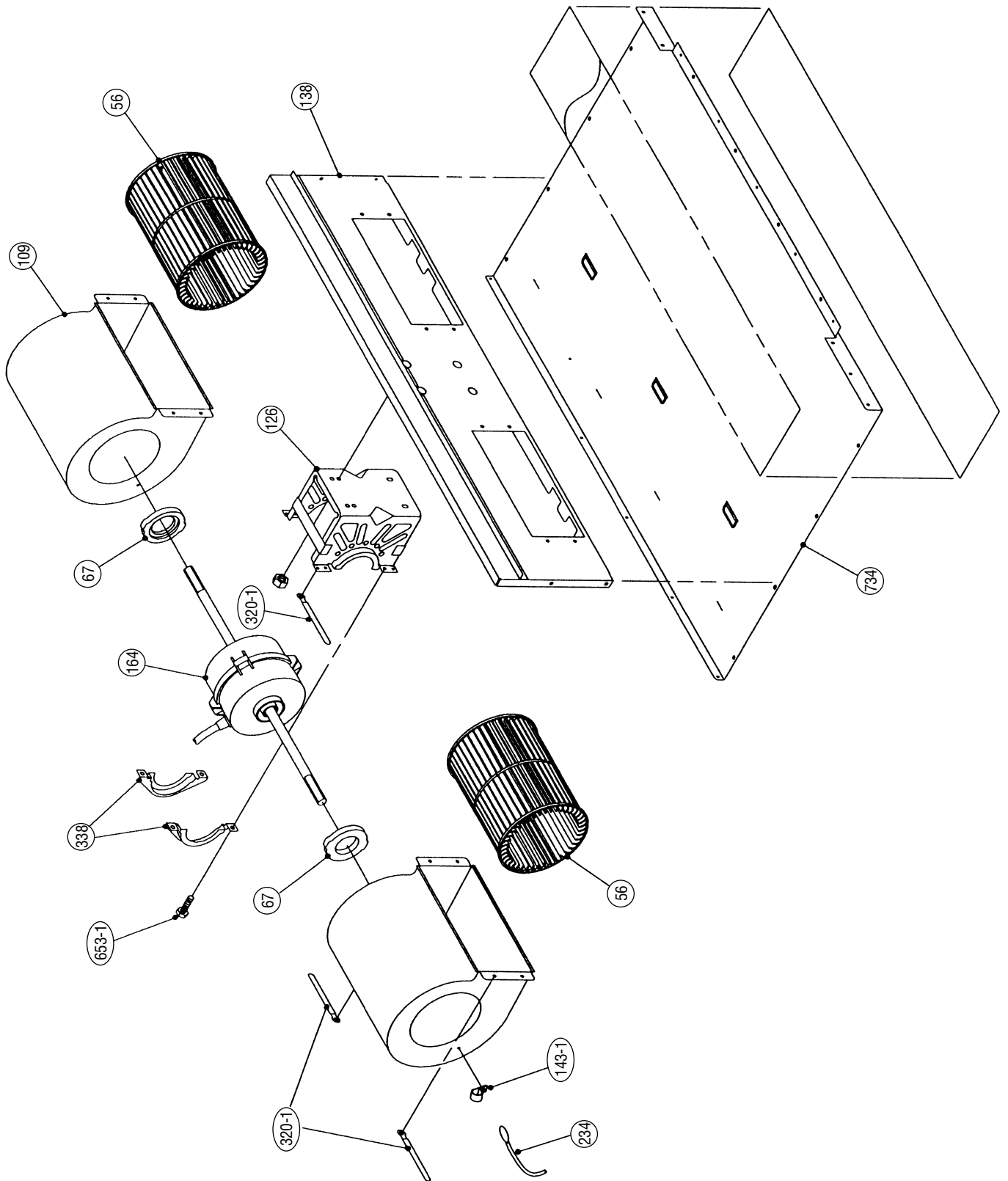

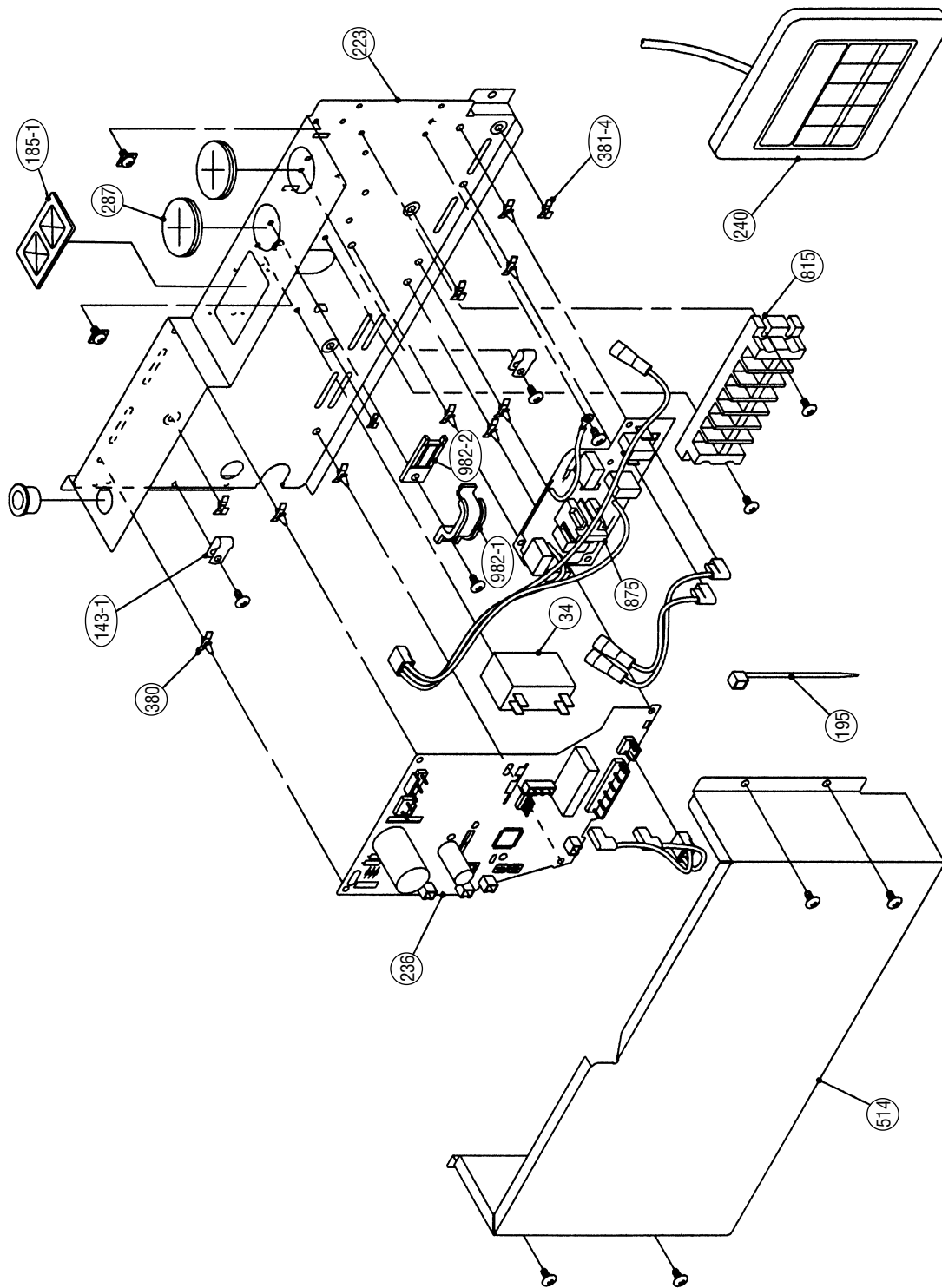

# PARTS LIST

## INDOOR UNIT

When you order parts, please make a photocopy of this page and fill the number of the parts in the "Order" column.

Ref. No.	Description	Part No.		Ord. Q'ty	Ref. No.	Description	Part No.		Ord. Q'ty
		RD-18HA	RD-18HAH				RD-18HA	RD-18HAH	
34	Capacitor (Fan Motor)	9357965017	9357965017		236	Controller PCB Assy	9704557155	9704557155	
56	Sirocco Fan Assy	9358621004	9358621004		240	Remote Control Unit	9371438030	9371438030	
63	Front Panel Assy	9363723007	9363723007		244	Cover (Piping)	9363327007	9363327007	
67	Rubber (Vibration-proof)	313659068604	313659068604		287	Cap (Power)	9352173011	9352173011	
74	Filter	9366833017	9366833017		320-1	Wire Clamp Metal	313483219905	313483219905	
109	Casing Assy	9363322002	9363322002		338	Motor Fixture	9358594001	9358594001	
126	Motor Fixing Table Assy	9358591000	9358591000		380	Locking Spacer	313209391403	313209391403	
138	Panel Assy (Motor)	9363401004	9363401004		381-4	Locking Spacer	0600118075	0600118075	
143-1	Clamp NK-3N	313361274700	313361274700		464	Cover (Cabinet)	9363400007	9363400007	
146	Evaporator Assy	9364456010	9364456010		514	Control Box Cover	9363201000	9363201000	
147	Inlet Pipe (Eva. ) Assy	9363382006	9363382006		567	Support Plate (Eva. )	9363404005	9363404005	
160	Drain Pan Assy	9364502021	9364502021		588-1	Bracket Eva. -R	9363199000	9363199000	
164	Fan Motor Assy	9600778173	9600778180		588-2	Bracket Eva. -L	9363198003	9363198003	
173	Hook Metal	9363195002	9363195002		625	Cord Bushing	9359240006	9359240006	
184-1	Thermo. Spring-A	313728262708	313728262708		653-1	Bolt (Fan Motor Fixing)	0700156014	0700156014	
185-1	Rubber Bushing	9357376004	9357376004		734	Panel Top	9363504002	9363504002	
195	Clamp SKB-100	313361275805	313361275805		761	Side Panel-R Assy	9363507003	9363507003	
196-2	Clamp SKB-150	313035356905	313035356905		762	Side Panel-L Assy	9363505009	9363505009	
223	Control Box	9366299004	9366299004		815	Terminal-7P	9703403019	9703403019	
232	Outlet Pipe (Eva. ) Assy	9363392005	9363392005		875	Filter PCB Assy	9703583018	9703583018	
234	Thermistor Assy-Room	9703299018	9703299018		982-1	Cord Clamp	9356857009	9356857009	
235	Thermistor Assy-Pipe	9703297052	9703297052		982-2	Cord Clamp-B	9356858006	9356858006	

When you order parts, please make a photocopy of this page and fill the number of the parts in the "Order" column.











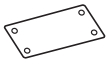

**OUTDOOR UNIT**

Ref. No.	Description	Part No.	Ord. Qty	Ref. No.	Description	Part No.	Ord. Qty
		ROD-18HA				ROD-18HA	
2	Fan Cover	9350214020		187	Clamp No. 1219	313361271706	
4	Emblem-Rear 9361328006			210	Main Relay	9356781007	
5	Cabinet-A, Painted	9303876015		233	Power Transformer	9900039011	
6	Cabinet-C, Painted	9353549013		235	Thermistor (Heat)	9900043025	
7	Connector Cover	9358011010		236	Controller PCB Assy	9704299048	
8	Wire Assy (Shield Tube)-D	9370945041		271	4-Way Valve Rubber	313728251908	
9	Cabinet-B, Painted	9303874011		300	Suction Pipe-C	9371276021	
10	Noise Insulation-E	313791106305		304	Thermostat Fixture-B	313349051500	
12	Base Assy, Painted	9353452054		328	Comp. Plate Assy-B	9363049039	
13	3-Way Valve Assy	9364523002		332-1	Suction Pipe-D	9367135004	
14	2-Way Valve Assy	9365021002		332-2	Suction Pipe-E	9369004001	
15	Dryer	9368111014		333	Accumulator	9350363018	
16	Condenser Assy	9353455048		334	Suction Pipe-B	9371275055	
17	U-Pipe (Y)	313728127102		338	Motor Fixture Metal	313029297108	
20	Discharge Pipe Assy	9371581019		343	Solenoid Coil	9359616108	
26	Compressor Cover-A	9363020007		344	4-Way Valve	313943302804	
29	Separate Wall	9302475011		348-1	Outlet Pipe-B	9365391020	
32-1	Control Box Metal-A	9357137001		360	4-Way Valve Band	313986251802	
32-2	Control Box Metal-B	9357138008		381	Locking Spacer	313209391506	
34	Capacitor (Fan Motor)	9357965024		549	Thermistor (Out Temp. )	9900037017	
36	Cord Holder Metal	9356934007		628	Locking Spacer-B	313005446558	
37	Running Capacitor	9704436023		646	Compressor Cover-B	9363021004	
38	Capacitor Clamp Metal	9351770013		678	Bracket (Thermistor)	313557406106	
39	Propeller Fan Assy	9300855013		717	Center Plate	9351253011	
41	Fan Motor Assy-Out	9600738207		735-1	Accumulator Supporter	9362274005	
45	Motor Fixing table Assy	313029311100		735-2	Outlet Pipe Assy	9371580012	
46	Compressor Assy	9367240005		735-3	Capillary Assy	9371287034	
55	Special Nut M8 (For Comp. )	9355091008		815	Terminal-5P	9356497021	
67	Rubber (Vibration-proof)	313659068604		838-1	Inlet Pipe-A Assy	9366859017	
107	Rubber Seat-A (For Comp. )	9351049010		867	Accumulator Holder Rubber	9354022027	
109	Terminal Cover (For Comp. )	9351048013		891	Thermistor Discharge	9900038014	
115	Joint Pipe (Dryer)	9365406007		910	Strainer-B	9365099018	





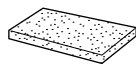

# STANDARD ACCESSORIES

## INDOOR UNIT ACCESSORIES

Name and Shape	Q'ty	Application	Parts No.
			RD-18HA, RD-18HAH
Installation template 	1	For positioning the indoor unit	9364225005
Hook metal 	4	For suspending the indoor unit from ceiling	9363195002
Tapping screw (ø 3 x 12) 	8	For installing the hanger	301171164104
Special nut A (large flange) 	4	For suspending the indoor unit from ceiling	313005446653
Special nut B (small flange) 	4		313005446759
Coupler heat insulation (large) 	1	For indoor side pipe joint (large pipe)	9350716029
Coupler heat insulation (small) 	1	For indoor side pipe joint (small pipe)	9352766015
Binder 	(Small) 1	For remote controller and remote controller cord binding	313361275805
	(Large) 4	For fixing the coupler heat insulation	312300787605
Remote control unit 	1		9371438030
Remote control unit cord clamp 	10	For installing the remote controller cord	313714181904
Tapping screw (flush heads) 	10	For installing the remote controller cord clamp	301141153027
Filter 	3		9366833017
Drain hose insulation 	1	Insulates the drain hose and vinyl hose connection	313806217708

## OUTDOOR UNIT ACCESSORIES

Name and Shape	Q'ty	Application	Parts No.
Hexagon wrench 	1	For vacuum	9351228019
Pipe (drain) 	1	For outdoor unit drain piping work (May not be supplied, depending on the model)	313728031005
Flexible tube 	1		313013042915
Cap (drain) 	2		313166024302



MANUFACTURER :

**Fuji Denki Sosetsu Co., Ltd.**

Tokyo, Japan