



**SPLIT TYPE
AIR CONDITIONER (50Hz)
DUCT type**

**SERVICE
MANUAL**

Models	Indoor unit	Outdoor unit
	RD-36CB	RO-36CB
	RD-36HA	RO-36HC

CONTENTS

SPECIFICATIONS	1
DIMENSIONS	2
CIRCUIT DIAGRAM	3
ERROR CONTENTS	5
REFRIGERANT SYSTEM DIAGRAM	6
INDOOR P. C. BOARD CIRCUIT DIAGRAM	7
OUTDOOR P. C. BOARD CIRCUIT DIAGRAM	9
DISASSEMBLY ILLUSTRATION	10
PARTS LIST	20
STANDARD ACCESSORIES	23

SPECIFICATIONS

INDOOR UNIT		RD-36CB	RD-36HA
OUTDOOR UNIT		RO-36CB	RO-36HC
COOLING CAPACITY	(kW)	10.3 - 10.5	10.3 - 10.5
HEATING CAPACITY	(kW)	—	10.5 - 10.7

ELECTRICAL DATA

POWER SOURCE	(V)	380 - 415		
FREQUENCY	(Hz)	50		
RUNNING CURRENT	(A)	COOLING	6.6 - 6.6	7.4 - 7.2
		HEATING	—	6.2 - 6.3
INPUT WATTS	(kW)	COOLING	3.90 - 4.00	4.20 - 4.30
		HEATING	—	3.35 - 3.40
E.E.R.	(kW/kW)	COOLING	2.64 - 2.63	2.45 - 2.44
		HEATING	—	3.13 - 3.15
MOISTURE REMOVAL	(ℓ/hr)	3.1		
AIR CIRCULATION-Hi	(m ³ /hr)	2,000		

Note : The above list shows values at the external static pressure of 98 Pa. (10 mm Aq.).

COMPRESSOR

TYPE	Hermetic type, 2 poles, 3-phase, Induction motor, Scroll
DISCRIMINATION	ZR48K3-TFD-501

FAN MOTOR

DISCRIMINATION (INDOOR UNIT)	MFA-45BTT	
POWER SOURCE	(V)	220 - 240
HI-SPEED	(r.p.m.)	1,280
MED-SPEED	(r.p.m.)	1,200
LO-SPEED	(r.p.m.)	1,130
DISCRIMINATION (OUTDOOR UNIT)	MFB-362FT	
POWER SOURCE	(V)	220 - 240
HI-SPEED	(r.p.m.)	770

Note : The above list shows values at the external static pressure of 0Pa, 415V.

DIMENSIONS

INDOOR UNIT	H x W x D (mm)	270 x 1,210 x 700
OUTDOOR UNIT	H x W x D (mm)	1,152 x 940 x 370

WEIGHT

INDOOR UNIT	GROSS / NET (kg)	60 / 45	
OUTDOOR UNIT	GROSS / NET (kg)	108 / 94	114 / 100

ADDITIONAL REFRIGERANT CHARGE (R-22)

PIPE LENGTH		10 m (33 ft)	20 m (66 ft)	30 m (99 ft)	40 m (132 ft)	50 m (164 ft)	g/m (oz / ft)
FULL CHARGE AMOUNT	RD-36CB	2,400 g (84.7 oz)	2,700 g (95.3 oz)	3,000 g (105.9 oz)	3,300 g (116.4 oz)	3,600 g (127.0 oz)	30 g/m (1.06 oz / 3.3 ft)
	RD-36HA	3,000 g (105.8 oz)		3,400 g (119.9 oz)	3,800 g (134.0 oz)	4,200 g (148.2 oz)	40 g/m (1.41 oz / 3.3 ft)

Note : When the piping is longer than 10 m (RD-36CB) and 20 m (RD-36HA), additional charge is necessary as the criteria, with 30 g (1.06 oz) / 1 m (3.3 ft) for RD-36CB, 40 g (1.41 oz) / 1 m (3.3 ft) for RD-36HA.

DIMENTIONS

Unit : mm

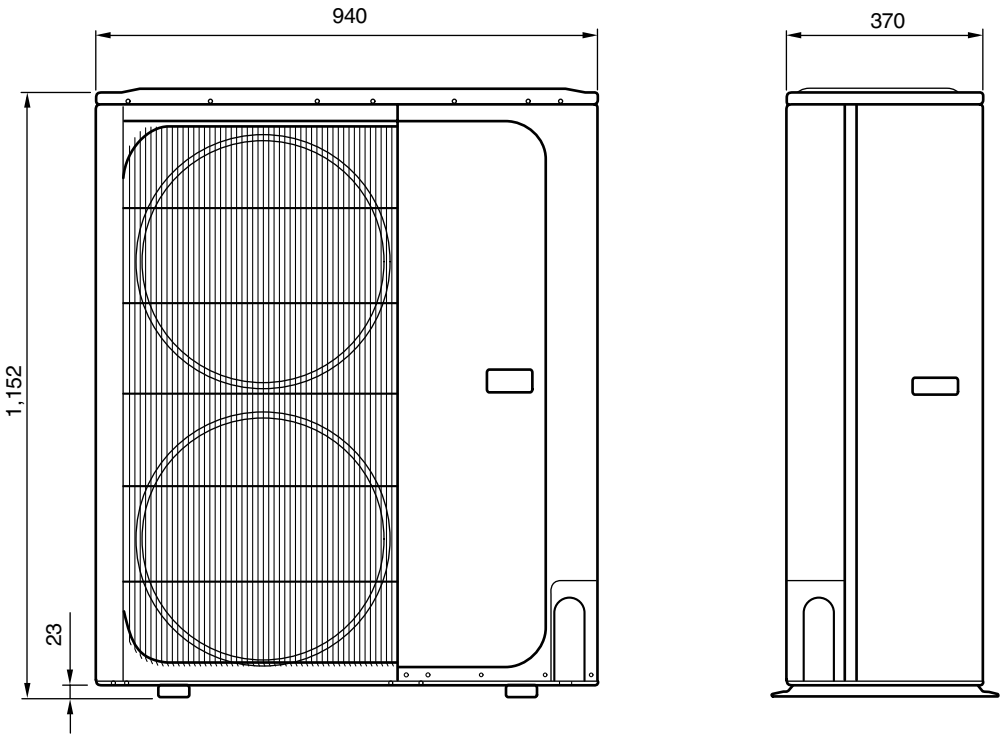
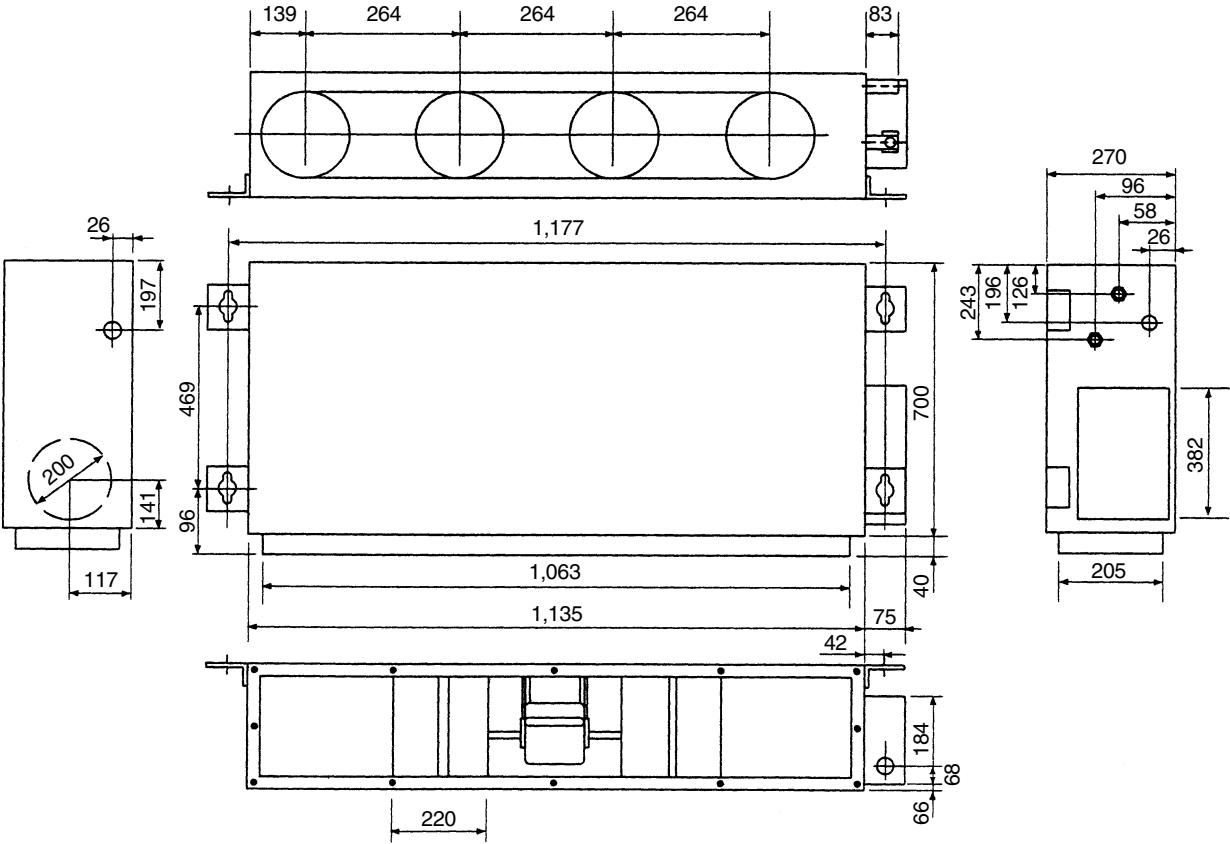

CIRCUIT DIAGRAM

Models : RD-36CB / RO-36CB

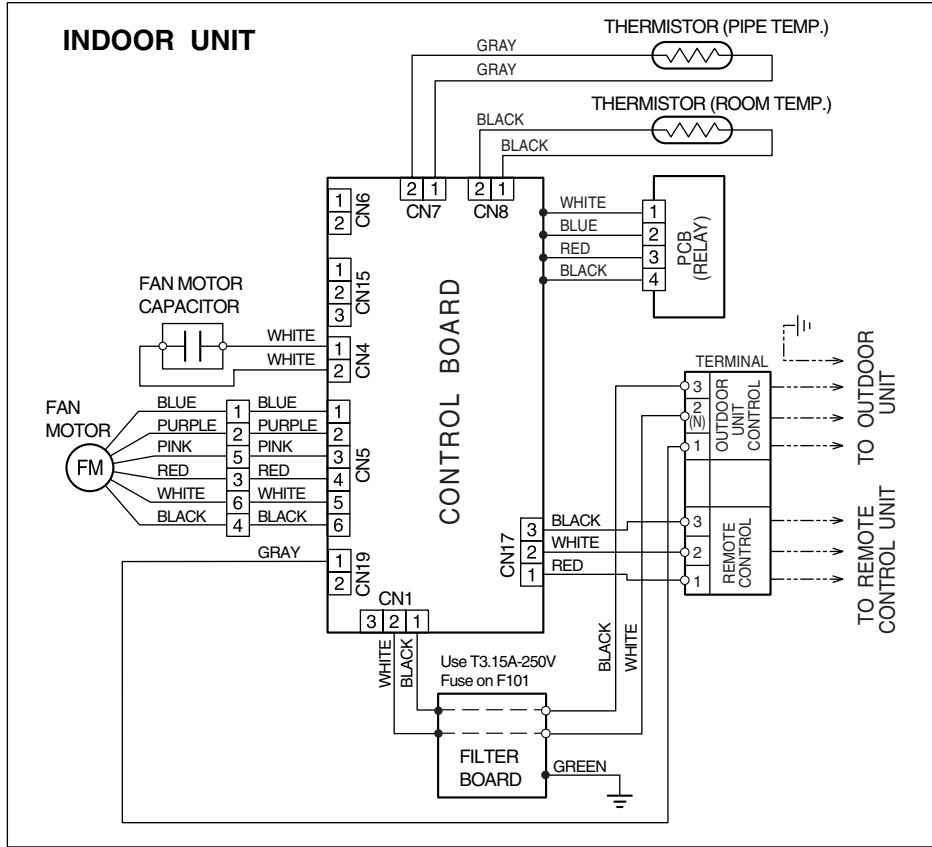

FAN MOTOR CAPACITOR	10.0 μ F
---------------------	--------------

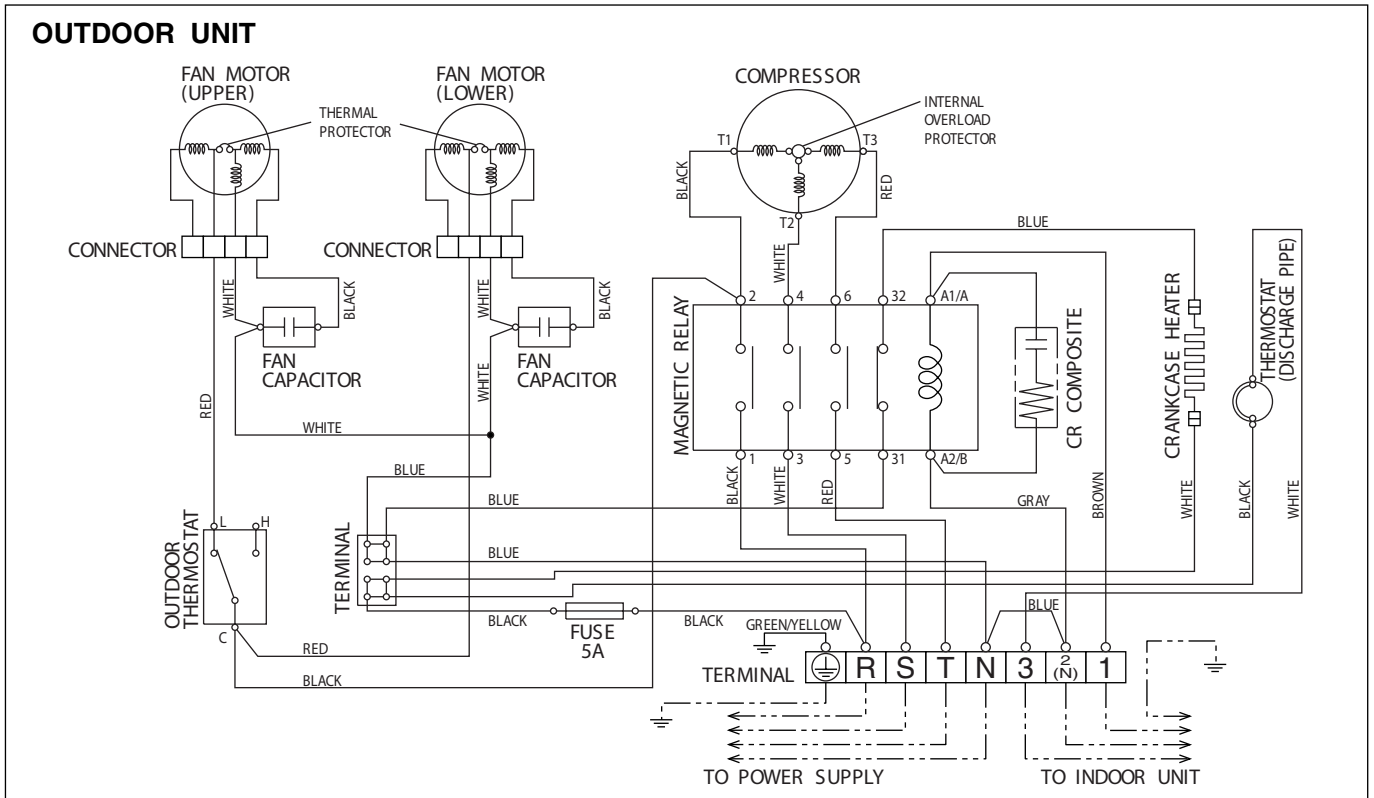

FAN MOTOR CAPACITOR	3.5 μ F
---------------------	-------------

Models : RD-36HA / RO-36HC

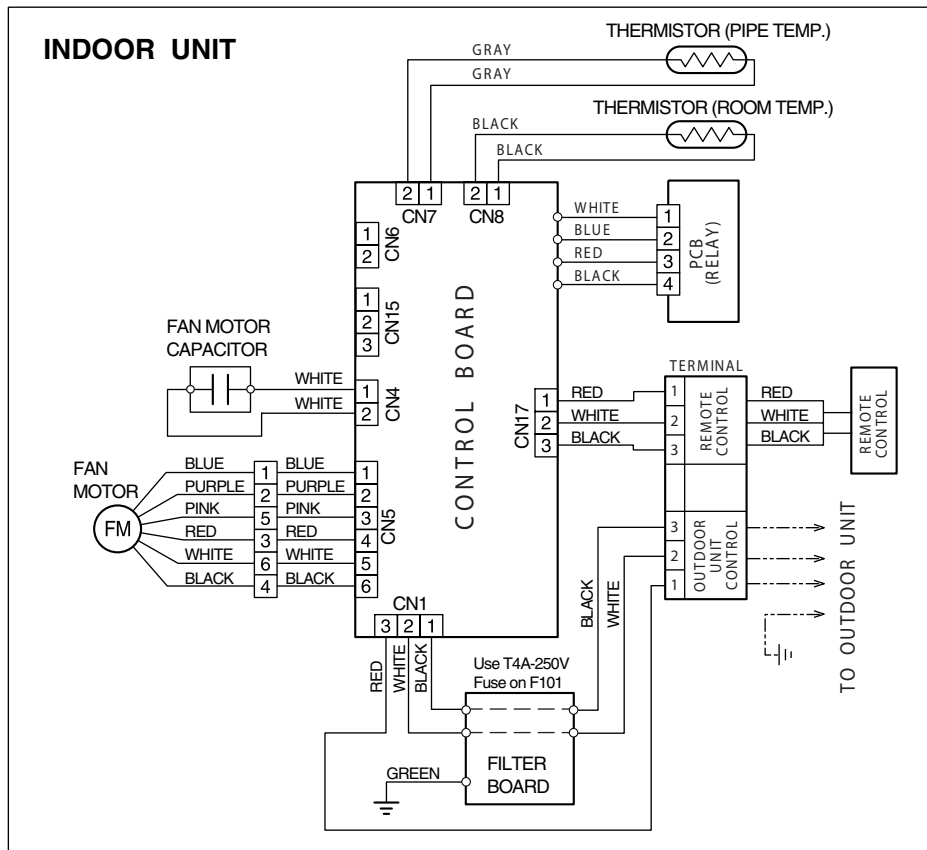

FAN MOTOR CAPACITOR 10.0 μF

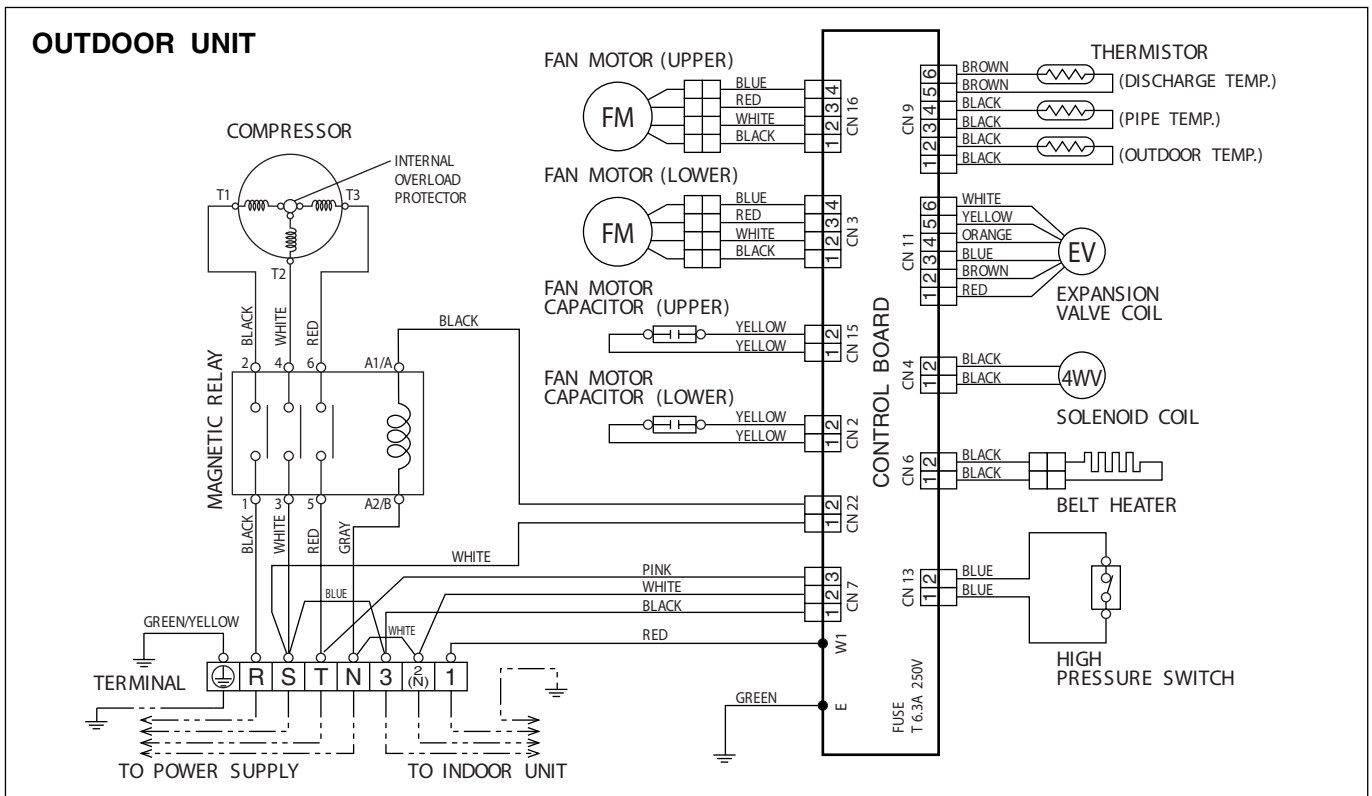

FAN MOTOR CAPACITOR 3.5 μF

ERROR CONTENTS

1. REMOTE CONTROLLER

When EE : EE blinks at the current time display, there is an error inside the air conditioner. If the SET TIME button (▼) and TEMP./DAY button (▼) are pressed simultaneously for more than three seconds, the self diagnosis check will start and the error contents will be displayed at the current time display. When the operation lamp lights, press the START/STOP button and after operation lamp goes off, perform the same operation. Process the error contents by referring to (Table 1).

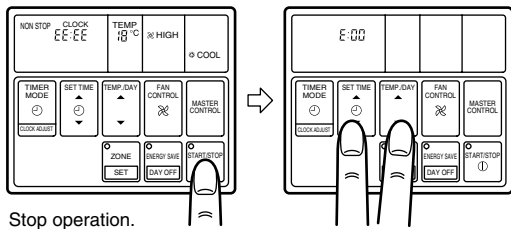

Stop operation.

Table 1

Error code	Error contents
E:00	Communication error (indoor unit ↔ remote controller)
E:01	Communication error (indoor unit ↔ outdoor unit)
E:02	Room temperature sensor open
E:03	Room temperature sensor short-circuited
E:04	Indoor heat exchanger temperature sensor open
E:05	Indoor heat exchanger temperature sensor short-circuited
E:06	Outdoor heat exchanger temperature sensor open
E:07	Outdoor heat exchanger temperature sensor short-circuited
E:08	Power source connection error
E:09	Float switch operated
E:0A	Outdoor temperature sensor open
E:0B	Outdoor temperature sensor short-circuited
E:0C	Discharge pipe temperature sensor open
E:0D	Discharge pipe temperature sensor short-circuited
E:0E	Outdoor high pressure abnormal
E:0F	Discharge pipe temperature abnormal
E:11	Model abnormal
E:12	Indoor fan abnormal
E:13	Outdoor signal abnormal
E:14	Outdoor EEPROM abnormal

To stop test running, press the START/STOP button.

For the operation method, refer to the operating manual and perform operation check.

Check that there are no abnormal sounds or vibration sounds during test running.

2. OUTDOOR UNIT

When the outdoor temperature drops, the outdoor unit's fans may switch to low speed, or one of the fans may stop intermittently.

ERROR : Heat & Cool model (Reverse cycle) only

The LED lamps operate as follows (Table 2) according to the error contents.

The LED lamps are on the outdoor unit board.

Table 2

Error contents	LED1	LED2	LED3	LED4	LED5	LED6
Signal abnormal	—	—	X	○	X	X
Indoor unit abnormal	—	—	X	X	○	X
Discharge pipe temperature abnormal	—	—	X	X	X	○
Outdoor heat exchanger temperature abnormal	—	—	X	X	○	○
Outdoor temperature abnormal	—	—	X	○	X	○
Power source connection error	—	—	○	X	X	X
EEPROM abnormal	—	—	○	○	○	○
	◎	◎	◎	◎	◎	◎
Outdoor high pressure abnormal	○	—	—	—	—	—
Discharge pipe temperature abnormal	—	○	—	—	—	—

○ : 0.5s ON / 0.5s OFF (flash)

X : OFF

◎ : 0.1s ON / 0.1s OFF (flash)

— : Indefinite

When the fault is cleared, the LED lamp goes off.

However, for discharge pipe temperature abnormal and high pressure abnormal, the LED lamp lights continuously for 24 hours, as long as the power is not turned off.

ERROR LED DISPLAY LAYOUT

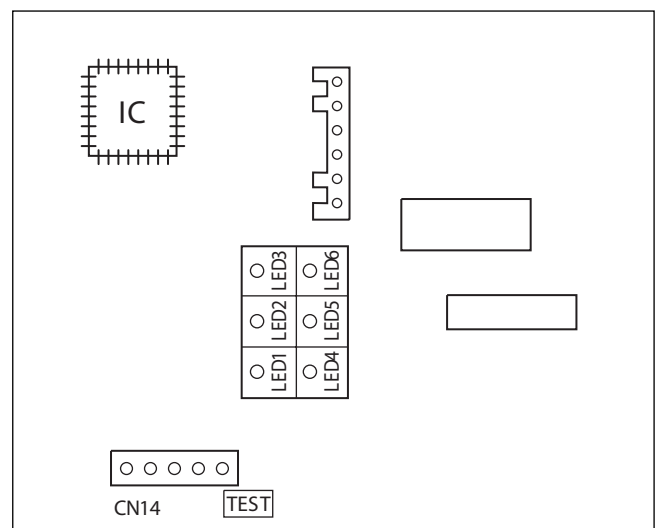

REFRIGERANT SYSTEM DIAGRAM

Models : RD-36CB / RO-36CB

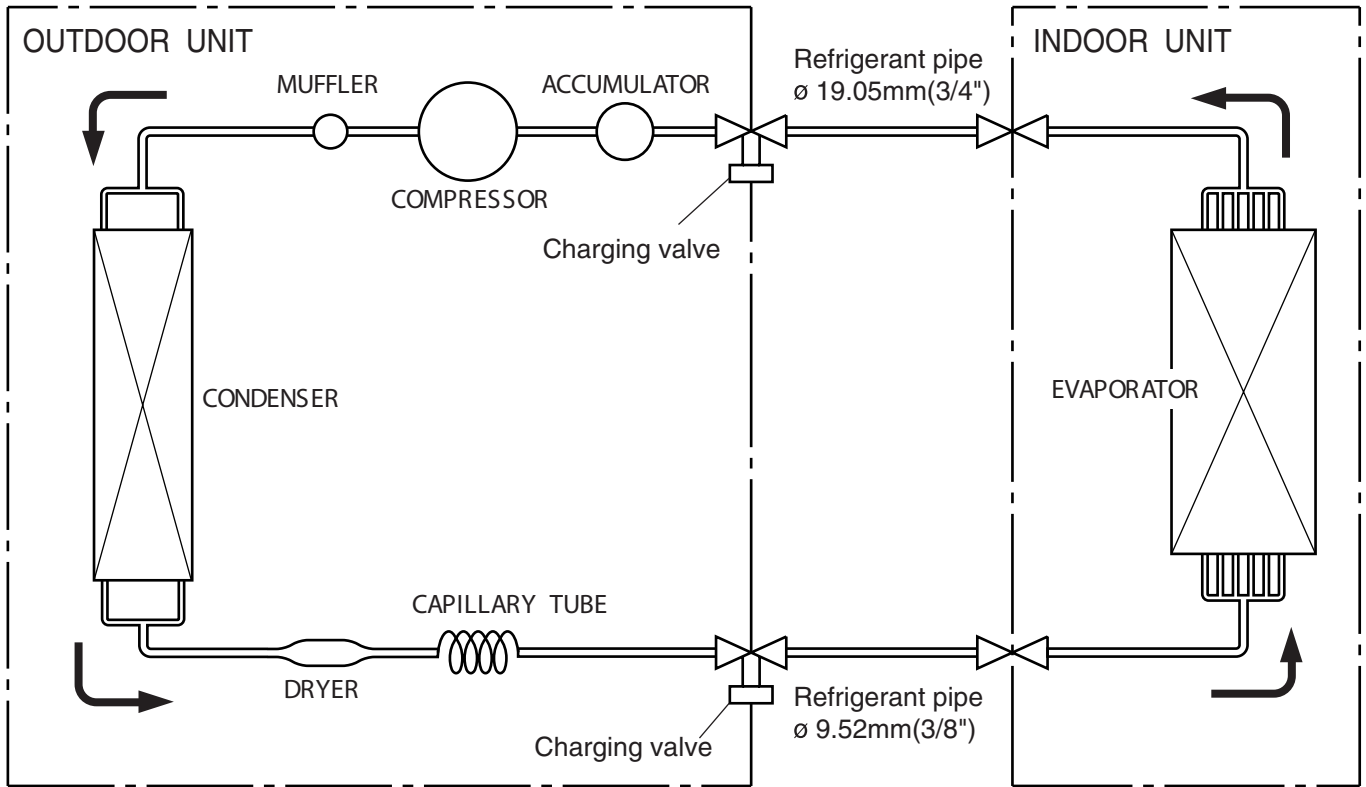

Models : RD-36HA / RO-36HC

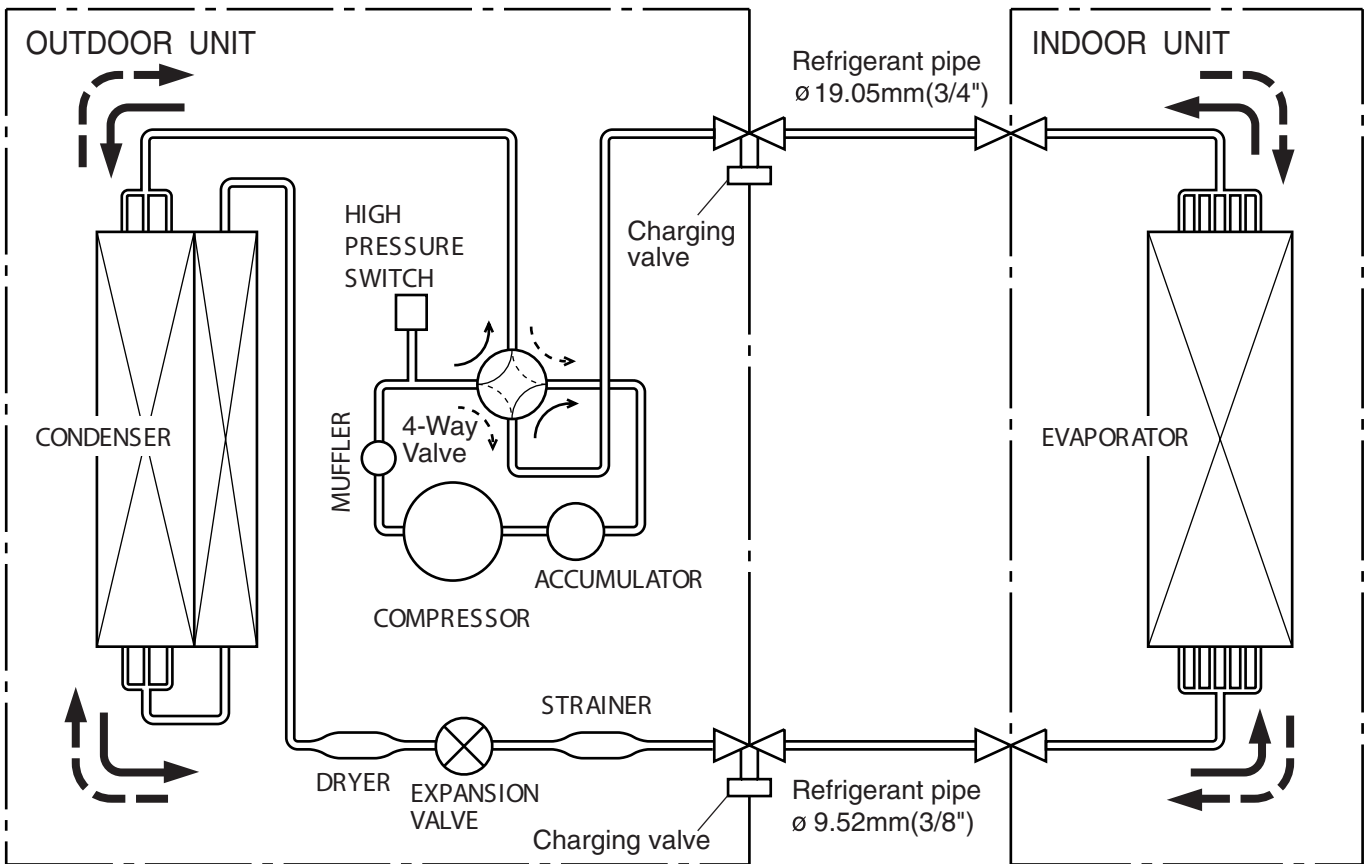

→ : COOL - - -> : HEAT

INDOOR PRINTED CIRCUIT BOARD CIRCUIT DIAGRAM

Model : RD-36CB

CONTROLLER PCB ASSEMBLY (MAIN PCB) EZ-002EWSE-C

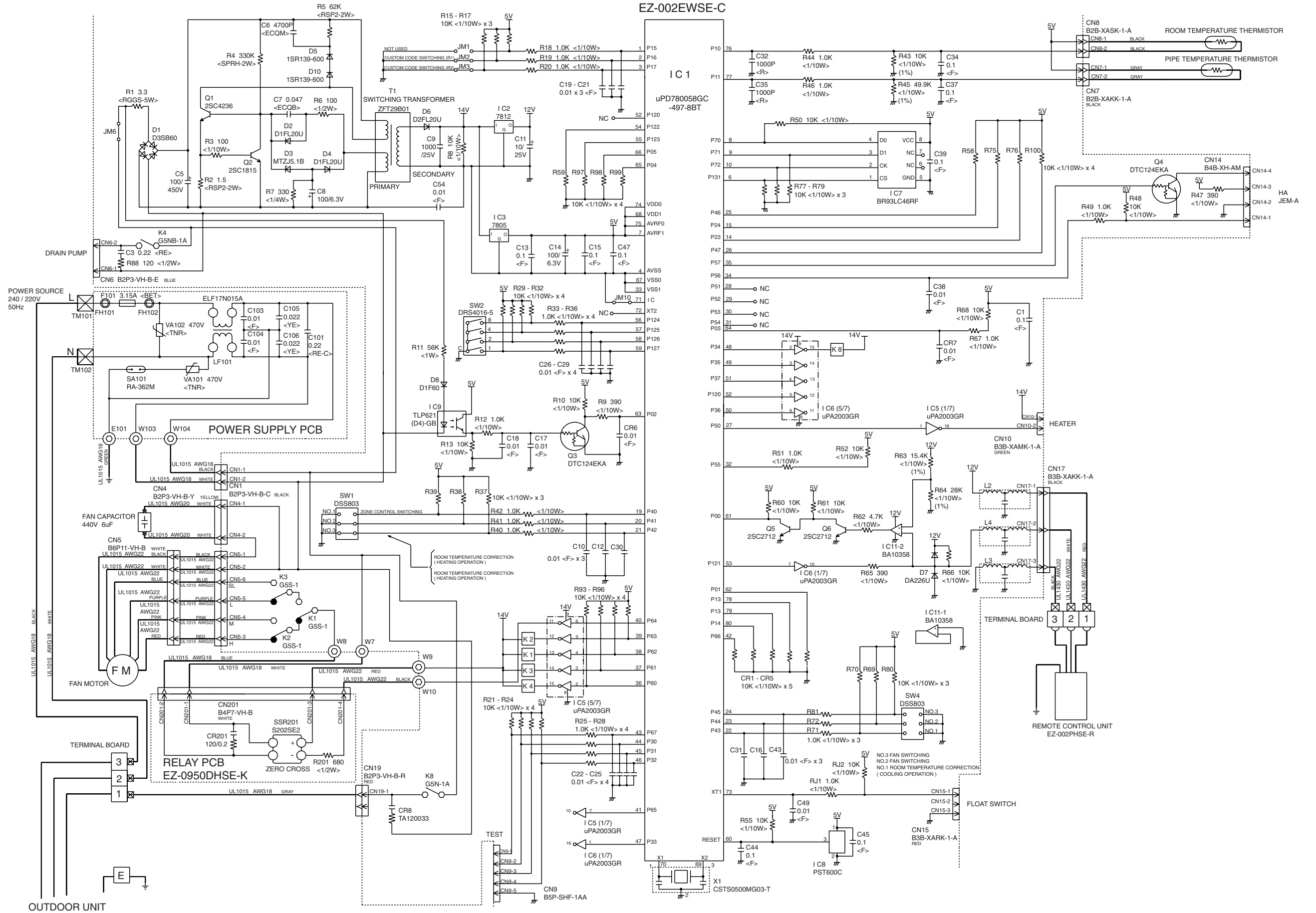

CONTROLLER PCB ASSEMBLY (MAIN PCB)

EZ-002PHSE-C

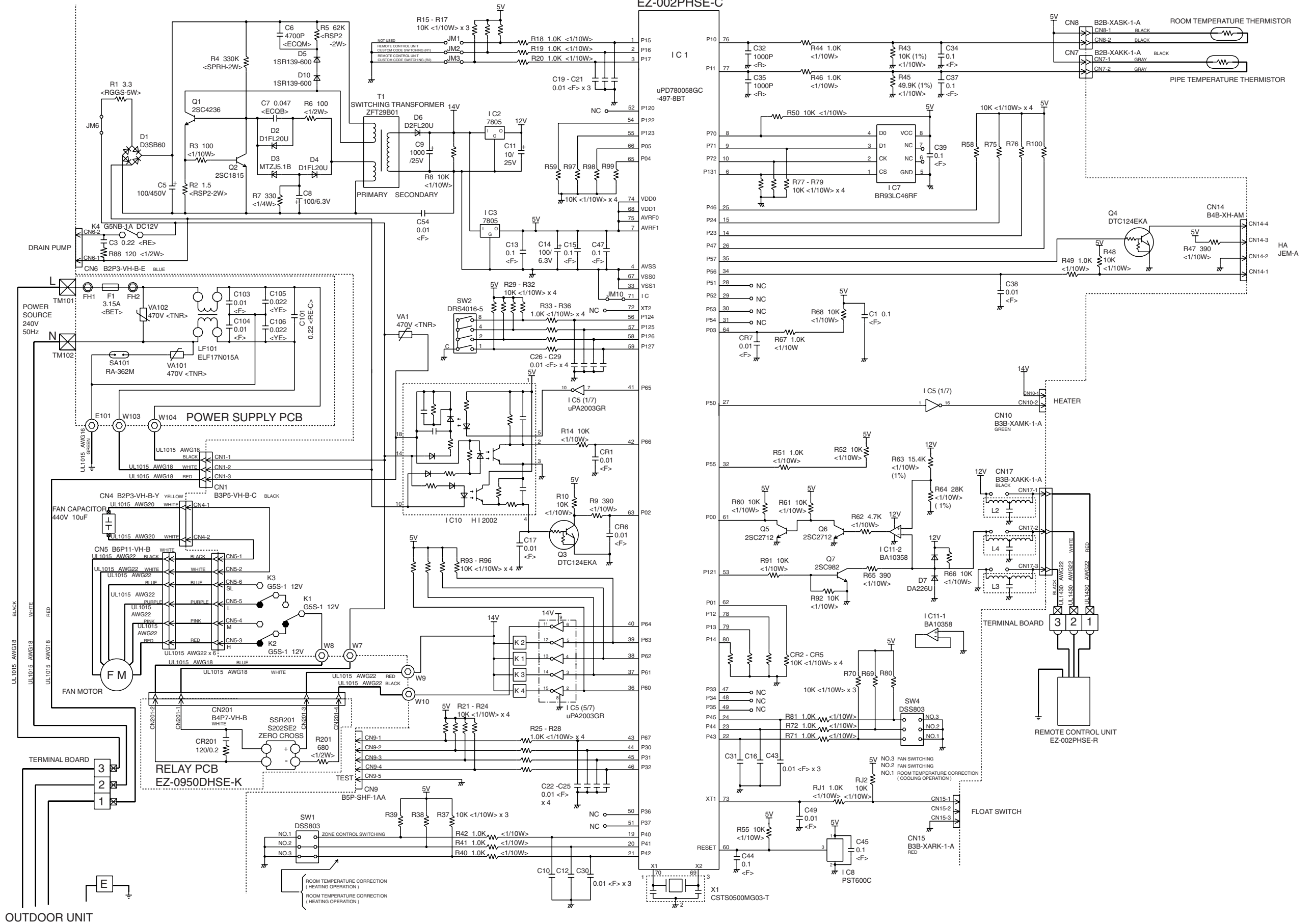

OUTDOOR UNIT

OUTDOOR PRINTED CIRCUIT BOARD CIRCUIT DIAGRAM

Model : RO-36HC

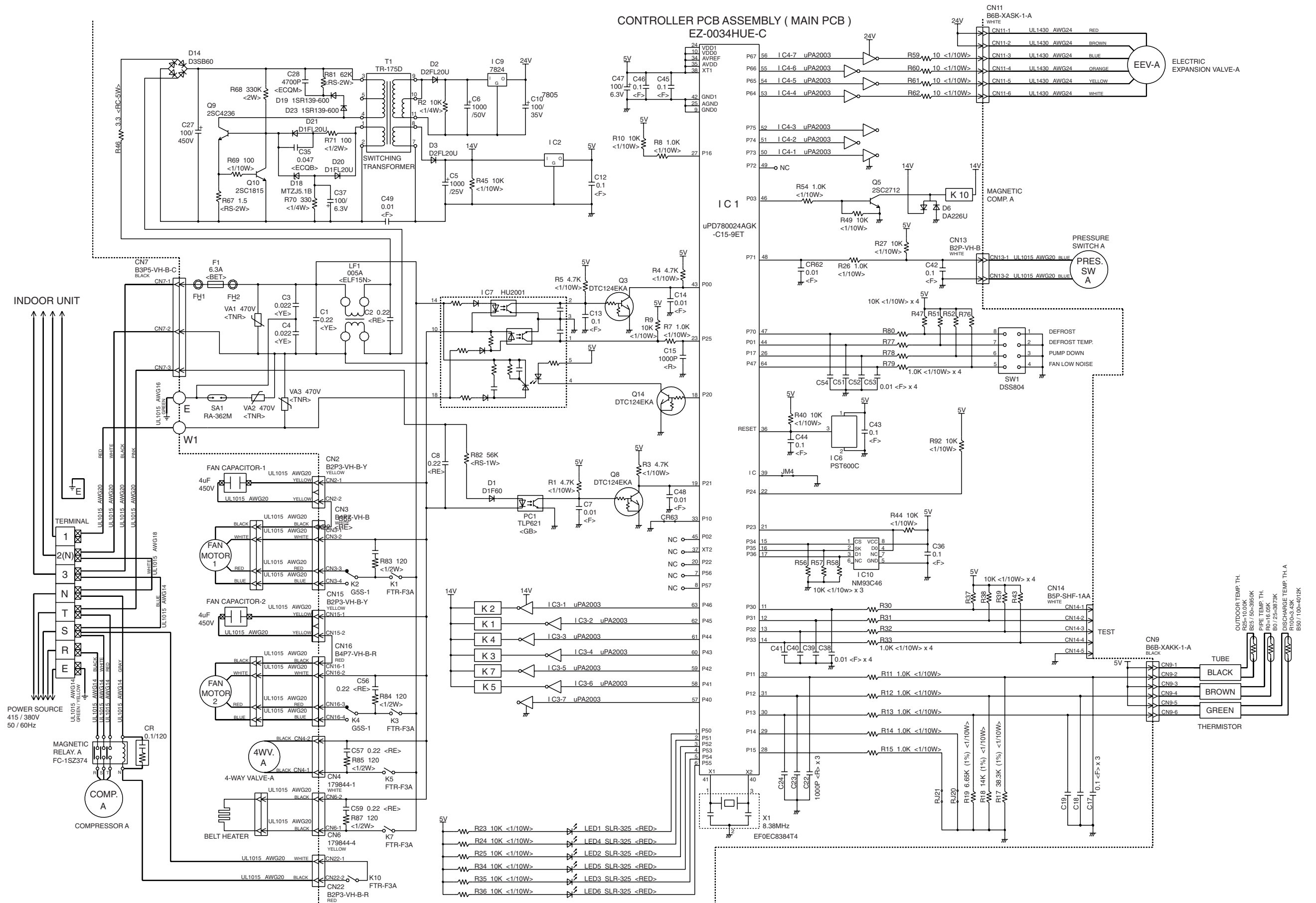

DISASSEMBLY ILLUSTRATION

Model : RO-36CB

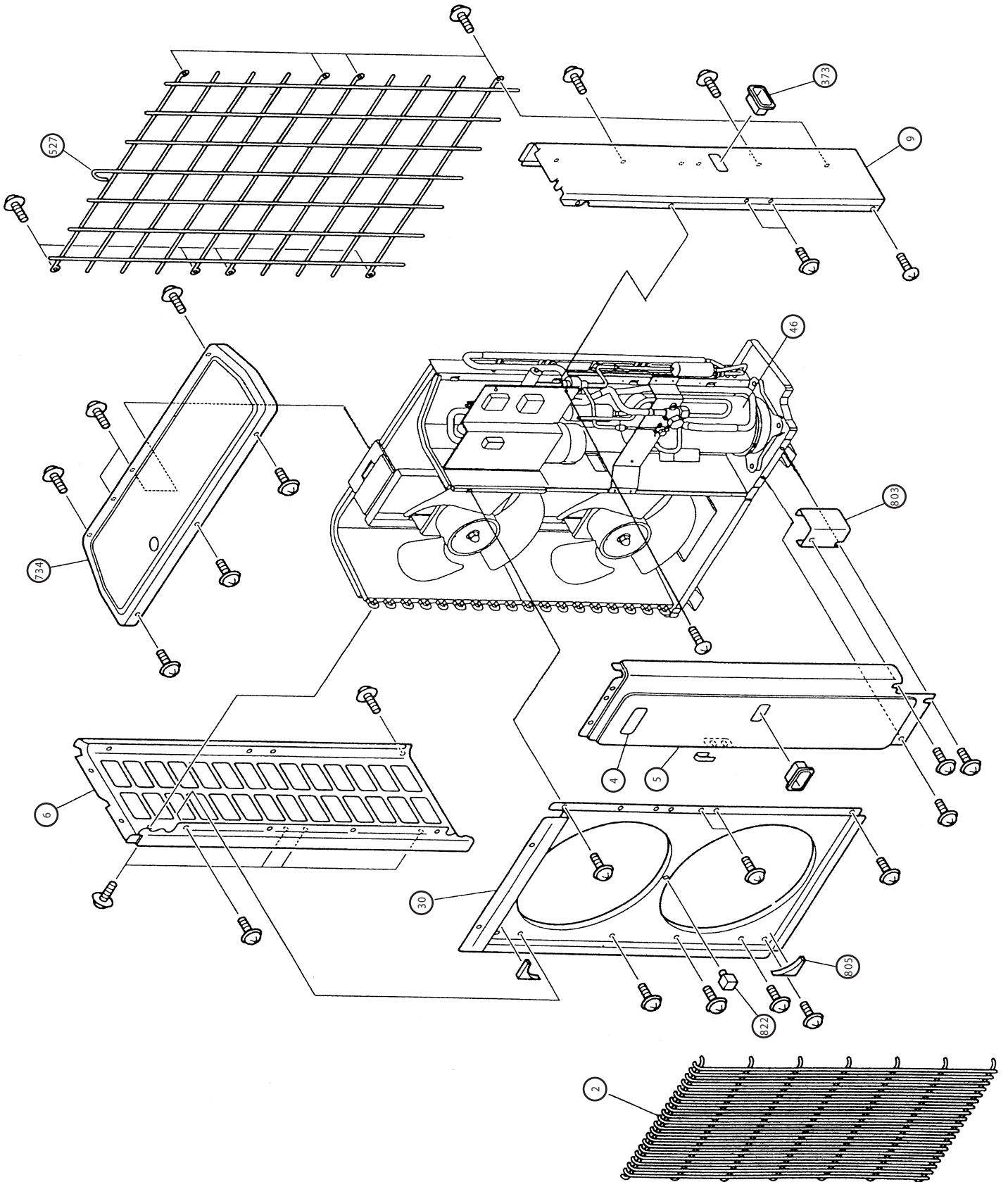

Model : RO-36CB

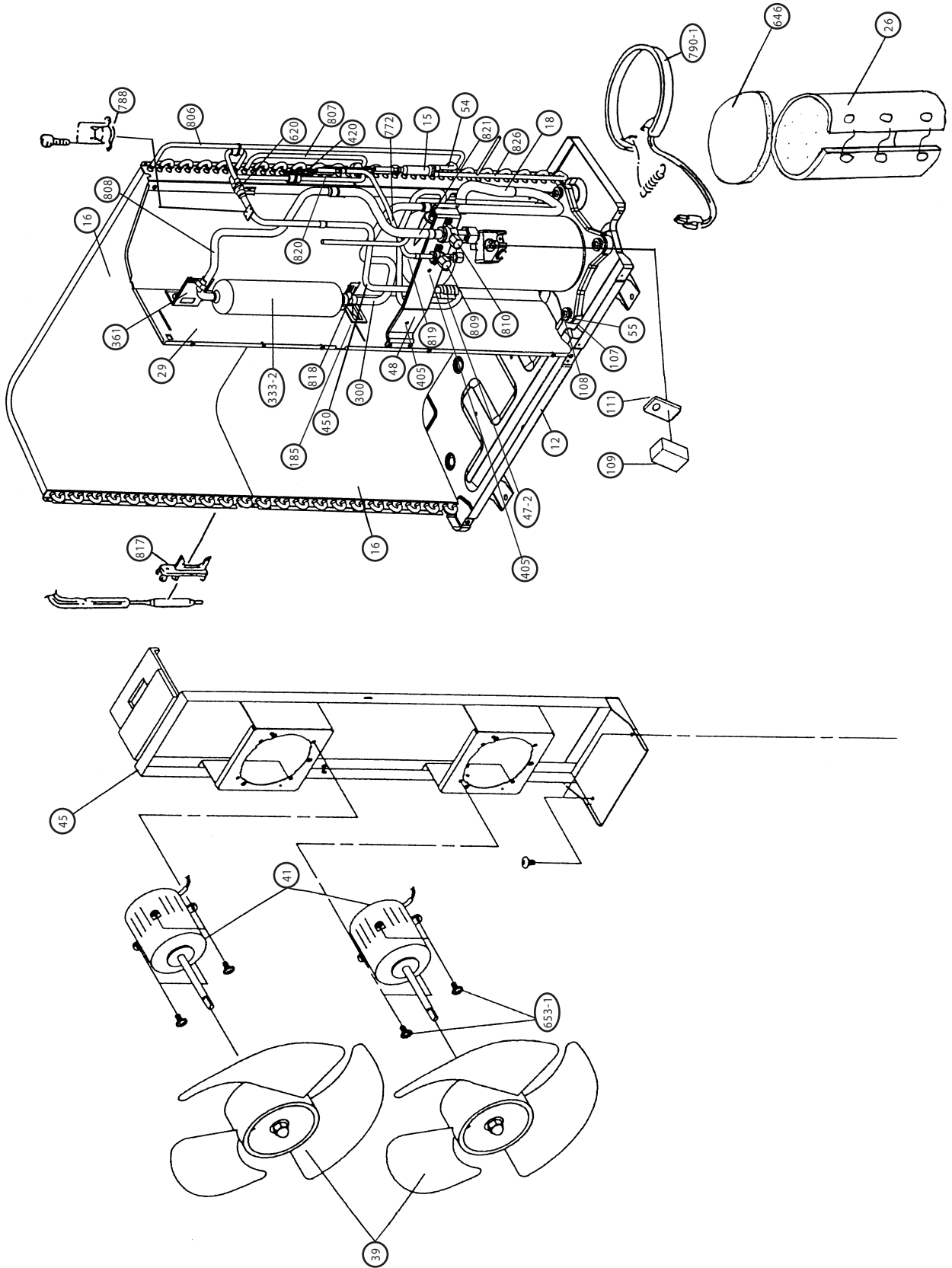

Model : RO-36CB

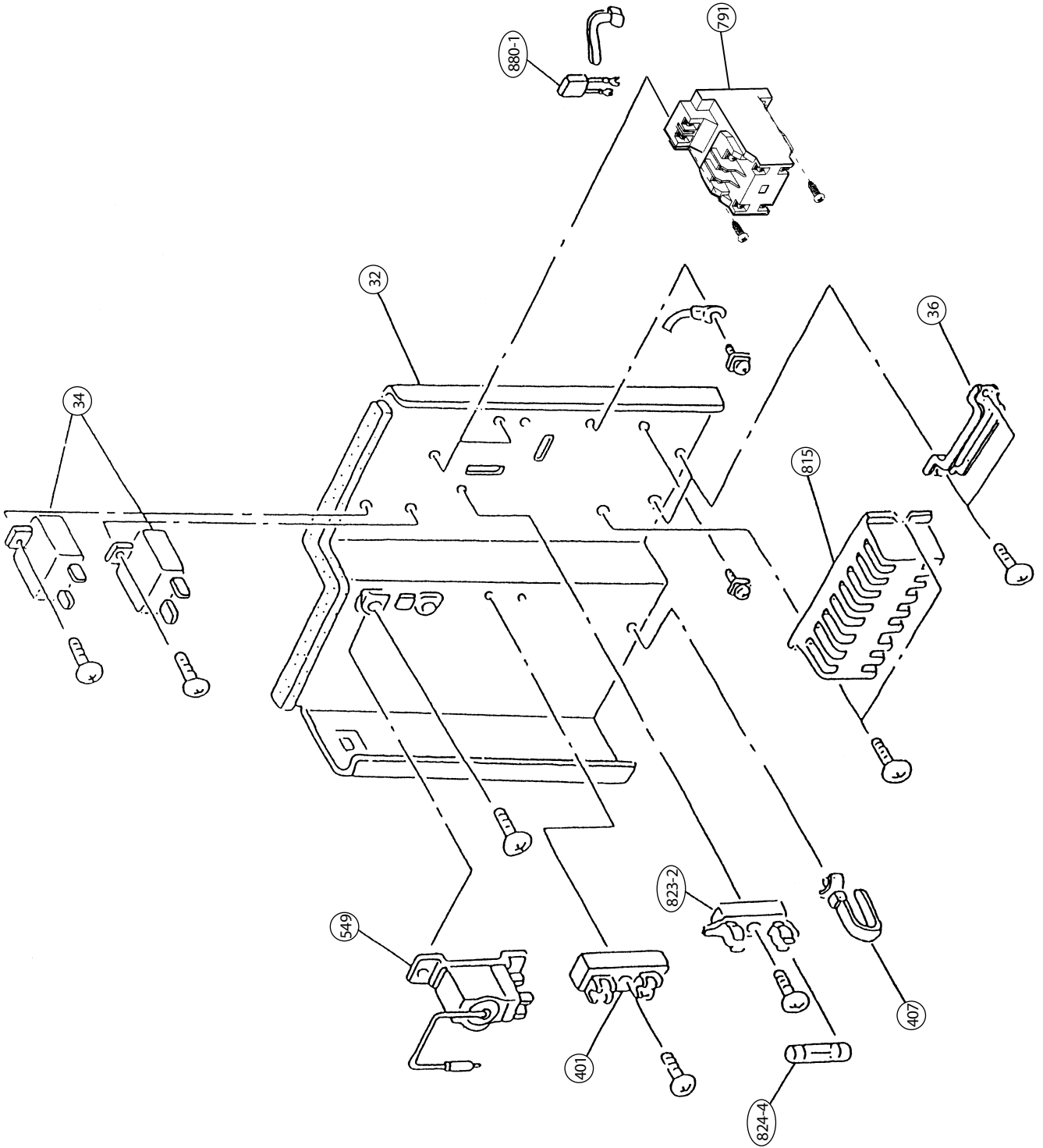

Model : RO-36HC

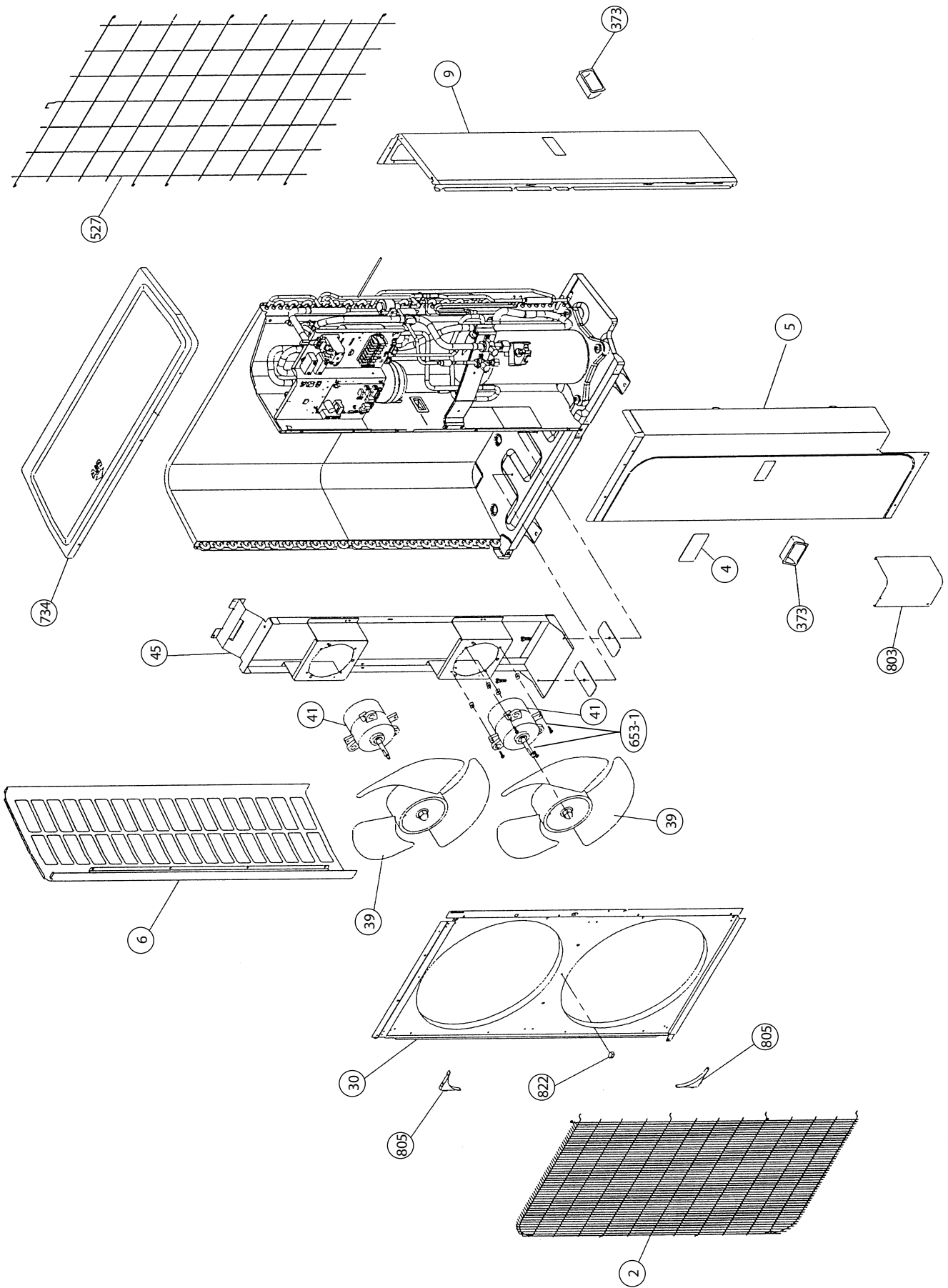

Model : RO-36HC

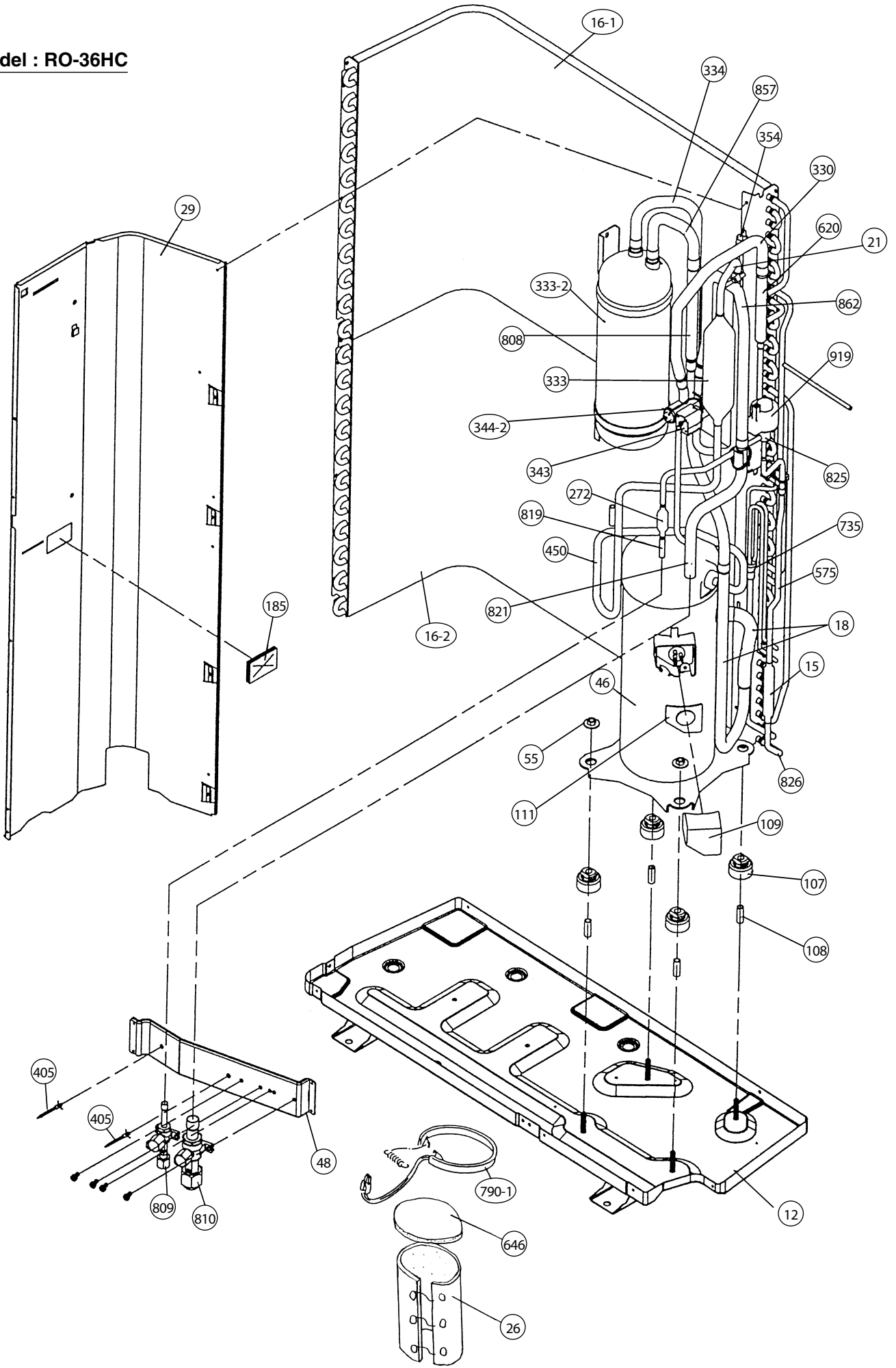

Model : RO-36HC

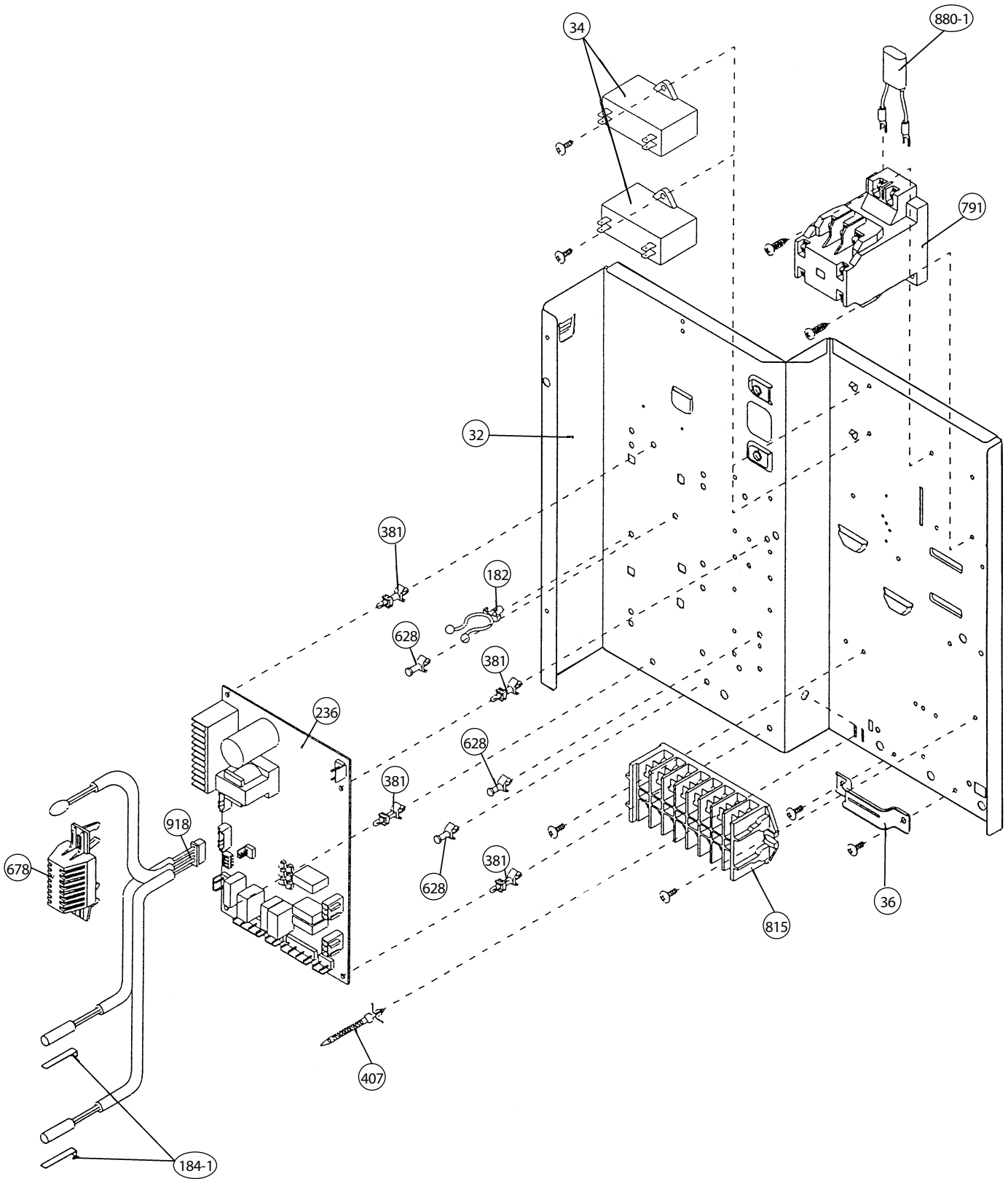

Models : RD-36CB, RD-36HA

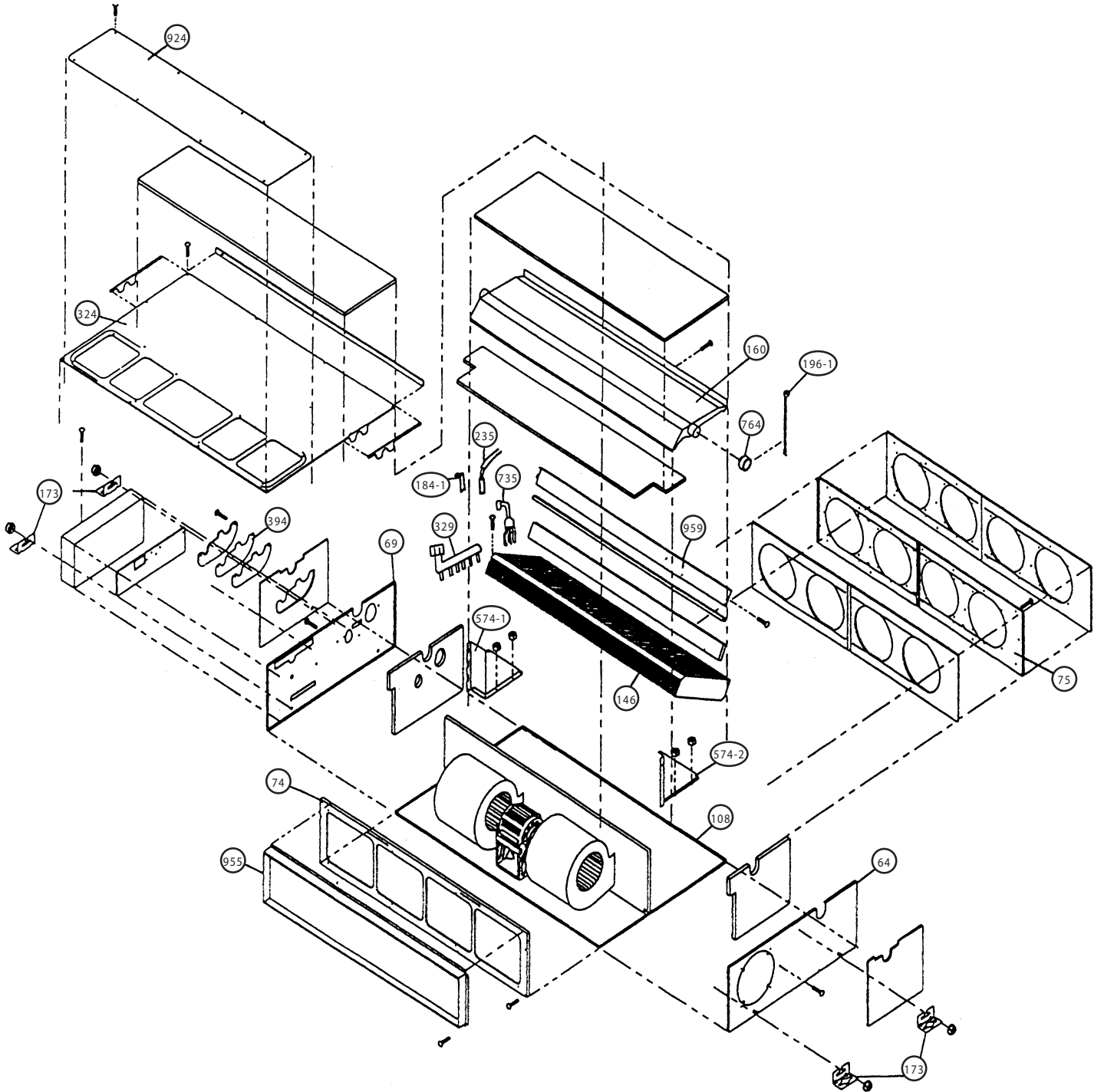

Models : RD-36CB, RD-36HA

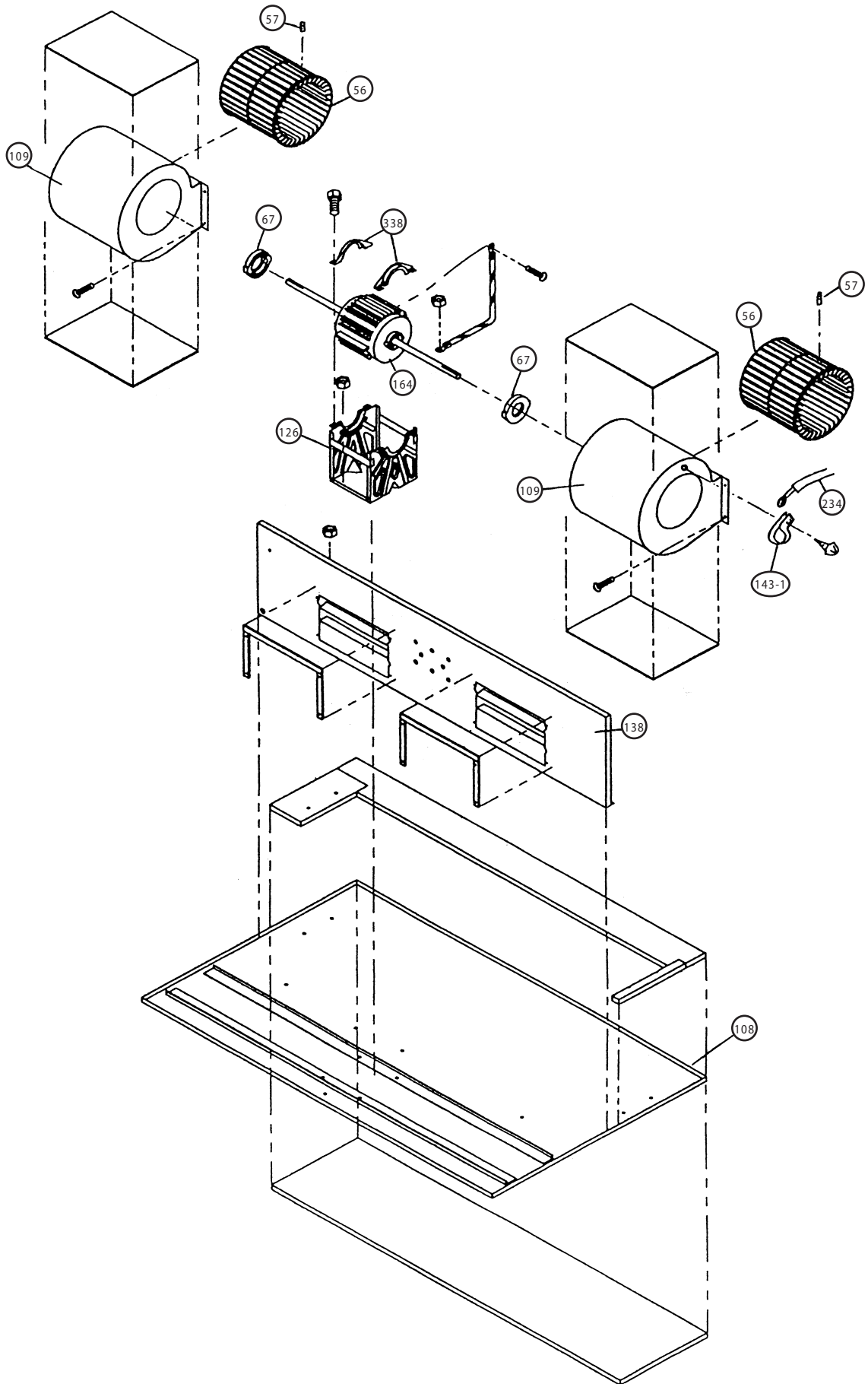

Model : RD-36CB

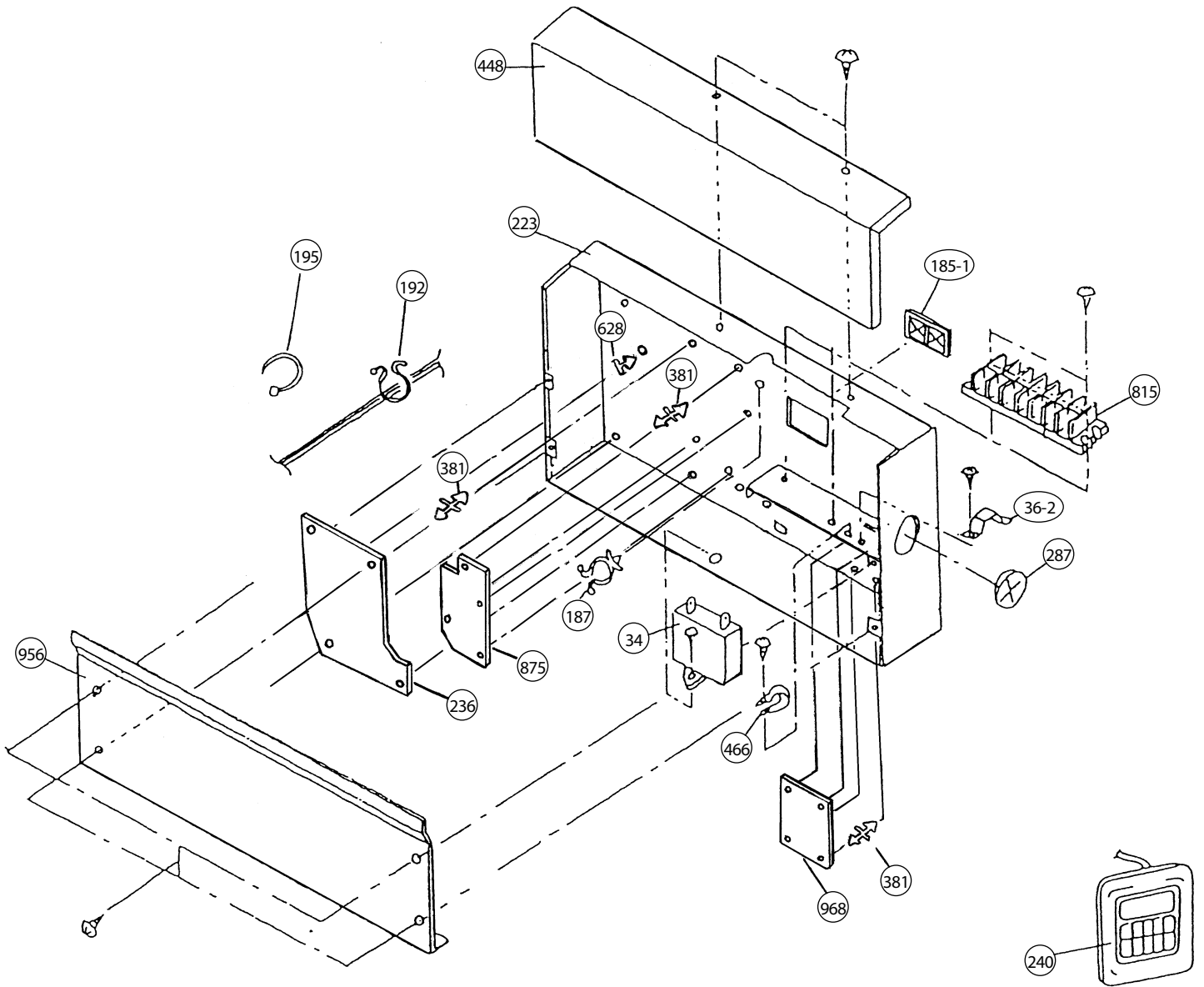

Model : RD-36HA

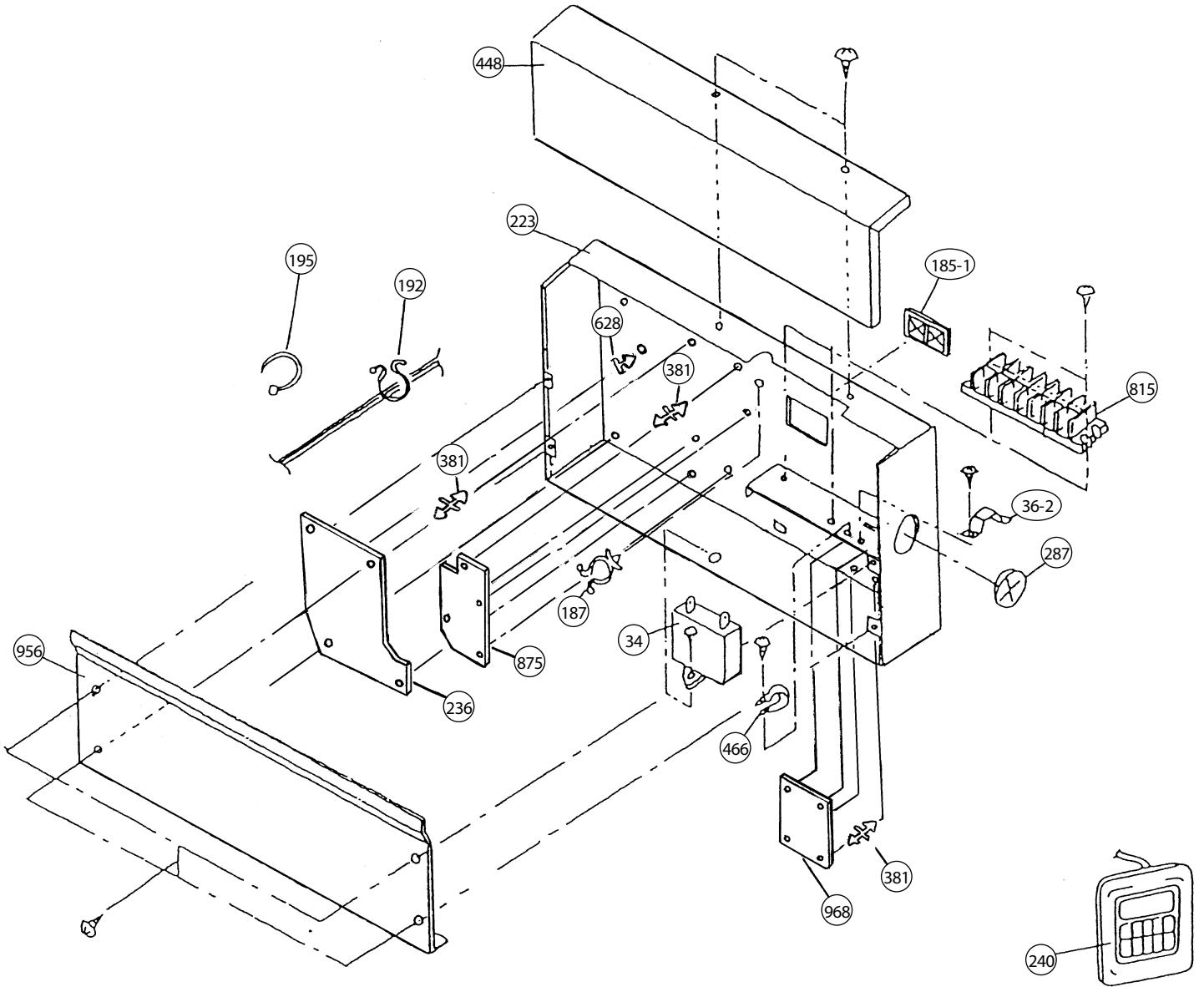

PARTS LIST

When you order parts, please make a photocopy of this page and fill the number of the parts in the "Order" column.

INDOOR UNIT

Ref. No.	Description	Part No.		Ord. Q'ty	Ref. No.	Description	Part No.		Ord. Q'ty
		RD-36CB	RD-36HA				RD-36CB	RD-36HA	
34	Capacitor (Fan Motor)	9704305053	9704305053		236	Controller PCB Assy	9704557056	9704557049	
36-2	Cord Holder Metal	9356362008	9356362008		240	Remote Control Unit	9703173066	9371438030	
56	Sirocco Fan Assy	9356531022	9356531022		287	Cap (Power)	9352173011	9352173011	
57	Hex. Socket Screw	313616213202	313616213202		324	Top Plate	9356546002	9356546002	
64	Cabinet-Left Metal	9356551006	9356551006		329	Coupling Pipe Assy	9357005003	9357005003	
67	Rubber (Vibration-proof)	313659068604	313659068604		338	Motor Fixture	9356536003	9356536003	
69	Cabinet-Right Metal	9356547009	9356547009		381	Locking Spacer	313209391506	313209391506	
74	Intake Panel	9356537000	9356537000		394	Pipe Fixing Plate	9356554007	9356554007	
75	Outlet Panel Assy	9356538007	9356538007		448	Control Box Metal-B	9356560008	9356560008	
108	Base Assy	9356518009	9356518009		466	Clamp NK-4N	313714328805	313714328805	
109	Casing Assy	9356527001	9356527001		574-1	Eva. Fixing Plate-R	9356521009	9356521009	
126	Motor Fixing Table Assy	9356533002	9356533002		574-2	Eva. Fixing Plate-L	9356522006	9356522006	
138	Separate Wall	9356523003	9356523003		628	Locking Spacer	313005446558	313005446558	
143-1	Clamp NK-3N	313361274700	313361274700		735	Distributor Assy	9357004006	9357004006	
146	Evaporator Assy	9356524017	9356524017		764	Drain Cap	9356541007	9356541007	
160	Drain Pan Assy	9356542028	9356542028		815	Terminal-7P	9703403019	9703403019	
164	Fan Motor Assy-IN	9600830017	9600830017		875	Filter PCB Assy	9704561053	9704561046	
173	Hanger Bracket	9356563009	9356563009		924	Intake Seal Plate	9356553000	9356553000	
184-1	Thermo. Spring-A	313728262708	313728262708		955	Square Flange Assy	9356555004	9356555004	
185-1	Rubber Bushing	9357376004	9357376004		956	Control Box Metal-E	9356900002	9356900002	
187	Clamp No.1219	313361271706	313361271706		959	Eva. Seal Plate	9356540000	9356540000	
192	Clamp No.062	313361271402	313361271402		968	Relay PCB Assy	9701594030	9701594030	
195	Clamp SKB-100	313361275805	313361275805						
196-1	Clamp SKB-3M	312300787605	312300787605						
223	Control Box Metal Assy	9356558005	9356558005						
234	Thermistor Assy-Room	9703299056	9703299056						
235	Thermistor Assy-Pipe	9703297045	9703297045						

OUTDOOR UNIT

When you order parts, please make a photocopy of this page and fill the number of the parts in the "Order" column.

Ref. No.	Description	Part No.		Ord. Qty
		RO-36CB	RO-36HC	
2	Fan Cover	9352159015	9352159015	
4	Emblem-Rear	9361328006	9361328006	
5	Cabinet-A, Painted	9352146015	9352146015	
6	Cabinet-C, Painted	9352149016	9352149016	
9	Cabinet-B, Painted	9352147012	9352147012	
12	Base Assy, Painted	9352136016	9352136016	
15	Dryer	9368117016	9368111014	
16	Condenser Assy	9352128011	—	
16-1	Condenser-A Assy	—	9353023001	
16-2	Condenser-B Assy	—	9353024008	
18	Suction Pipe Assy	9372226025	9372226025	
21	Discharge Pipe-B	—	9372246023	
26	Compressor Cover-A	9370774030	9370774030	
29	Separate Wall	9355277013	9355277013	
30	Blower Cover, Painted	9352151019	9352151019	
32	Control Box Metal	9352134012	9352134012	
34	Capacitor (Fan Motor)	9703306051	9703306051	
36	Cord Holder Metal	9356934007	9356934007	
39	Propeller Fan Assy	9366378013	9366378013	
41	Fan Motor Assy-Out	9600832028	9600832028	
45	Bracket (Motor) Assy	9368108007	9368108007	
46	Compressor-C Assy	9371396033	9371396033	
47-2	Rubber (Discharge Pipe)	313194159807	—	
48	Bracket (Coupler) Assy	9355281010	9355281010	
54	Condensing Pipe-A	9364070001	—	
55	Special Nut M8 (For Comp.)	9355091008	9355091008	
107	Rubber Seat-A (For Comp.)	9364084008	9364084008	
108	Sleeve-A (For Comp.)	9364085005	9364085005	
109	Terminal Cover (For Comp.)	9364087009	9364087009	
111	Terminal Packing	9364086002	9364086002	
182	Clamp No.249	—	313361271505	
184-1	Thermo. Spring-A	—	313728262708	
185	Rubber Bushing	313005066051	313005066051	
236	Controller PCB Assy	—	9704764133	
272	Strainer Assy	—	9354139008	
300	Suction Pipe-C	9372228029	—	
330	Inlet Pipe (Cond.)-A	—	9372239025	
333	Accumulator	—	9350363018	
333-2	Accumulator (B)	9301942019	—	
333-2	Accumulator Assy (B)	—	9371615011	
334	Suction Pipe-B	—	9372227022	
343	Solenoid Coil	—	9900165024	
344-2	4-Way Valve	—	9900164010	
354	Pressure Switch	—	9704045003	
361	Accumulator Support	9355351003	—	
373	Grip	9352157004	9352157004	
381	Locking Spacer	—	313209391506	
401	Terminal-2P	9701971015	—	
405	Clamp No.1763	313816345304	313816345304	
407	Clamp (Cable) No.1259	313739340109	313739340109	
420	Capillary Assy	9371224047	—	
450	Discharge Pipe-A	9372229033	9372229026	
527	Protection Net	9352163012	9352163012	
549	Thermistor-Outdoor	9352426001	—	
575	Condensing Pipe-C	—	9372225028	
620	Inlet Pipe (Cond.) Assy	9355316026	9372224021	
628	Locking Spacer	—	313005446558	
646	Compressor Cover-B	9370774047	9370774047	
653-1	Bolt (Fan Motor Fixing)	9385089020	9385089020	
678	Bracket (Thermistor)	—	313557406106	











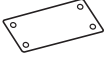

OUTDOOR UNIT (Continued)

When you order parts, please make a photocopy of this page and fill the number of the parts in the "Order" column.

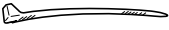

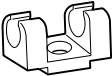





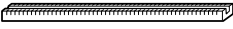

Ref. No.	Description	Part No.		Ord. Qty
		RO-36CB	RO-36HC	
734	Cabinet Top Plate	9352161018	9352161018	
735	Distributor Assy	—	9372230022	
772	Joint Pipe (Valve-A)	9370739039	—	
788	Thermistor-Overheat	9354061002	—	
790-1	Belt Heater-A	9361140066	9361140066	
791	Magnetic Relay	9900078010	9900078010	
803	Cabinet-D, Painted	9352150012	9352150012	
805	Blower Cover Corner	9352160011	9352160011	
806	Cond. Pass Pipe-A	9352294006	—	
807	Cond. Pass Pipe-B	9353090010	—	
808	Inlet Pipe (Accumulator)	9352556005	—	
808	Inlet Pipe (Accumulator)-A	—	9372244029	
809	Ball Valve-A	9371799049	9371799049	
810	Ball Valve-B	9371799056	9371799056	
815	Terminal-8P	9363276022	9363276022	
817	Thermostat Fixture	9352164019	—	
818	Accumulator Support-B	9355350006	—	
819	Valve-A Coupl. Pipe	9370739039	9363457001	
820	Joint Pipe (Capillary)	9352299001	—	
821	Joint Pipe (Valve-B)	9352284007	9352284007	
822	Fan Cover Fixture-A	9352158018	9352158018	
823-2	Fuse Holder	0500063024	—	
824-4	Fuse	0600222529	—	
825	Expansion Valve	—	9900170011	
826	Condensing Pipe-B	9364102009	9372231012	
857	Inlet Pipe (Accumulator)-B	—	9372244036	
862	Valve-B Coupl. Pipe	—	9372243022	
880-1	Network	9700987017	9700987017	
918	Thermistor Assy	—	9900129019	
919	Expansion Valve Coil	—	9900172015	

STANDARD ACCESSORIES

INDOOR UNIT ACCESSORIES

Name and Shape	Q'ty	Application	Part No.	
			RD-36CB	RD-36HA
Installation template 	1	For positioning the indoor unit	9357036007	9357036007
Hanger 	4	For suspending the indoor unit from ceiling	9356563009	9356563009
Special nut A (large flange) 	4	For suspending the indoor unit from ceiling	313005446653	313005446653
Special nut B (small flange) 	4		313005446759	313005446759
Coupler heat insulation (large) 	2	For indoor side pipe joint (large pipe)	9350716029	9350716029
Coupler heat insulation (small) 	1	For indoor side pipe joint (small pipe)	9352766015	9352766015
Nylon fastener 	1	For fixing the drain hose	312300787605	312300787605
Remote controller 	1		9703173066	9371438030
Remote controller cord clamp 	10	For installing the remote controller cord	313714181904	313714181904
Tapping screw (flush heads) 	10	For installing the remote controller cord clamp	301141153027	301141153027
Auxiliary pipe assembly 	1	For wiring conduit (gas side) connection	9357038001	9357038001
Drain hose insulation 	1	Insulates the drain hose and vinyl hose connection	313806217708	313806217708

OUTDOOR UNIT ACCESSORIES

Name and Shape	Q'ty	Application	Part No.	
			RO-36CB	RO-36HC
Power cap 	1	For power cord installation	9352173011	9352173011
Auxiliary pipe assembly 	1	For wiring conduit (gas side) connection (May not be supplied, depending on the model)	9355292016	9355292016
Edge cover 	1	For wiring conduit installation hole edge protection	9352436000	9352436000
Tapping screw 	2	For cabinet A and cabinet D mounting (1) Spare (1)	301463040100	301463040100
Binder 	1	For power cord binding	313035356905	313035356905
Putty 	1	For sealing	303020200114	303020200114
Coupler heat insulation 	1	For outdoor side pipe joint	313005074759	313005074759
Pipe (drain) 	2	For outdoor unit drain piping work	—	313728031005
Flexible tube 	2		—	313013042915
Cap (drain) 	2		—	313166024302

