



SPLIT TYPE AIR CONDITIONER (50Hz)

DUCT type

SERVICE MANUAL

Models	Indoor unit	Outdoor unit
	RD-45CA	ROCW-457
	RD-45HA	RO-45HA

C O N T E N T S

SPECIFICATIONS	1
CIRCUIT DIAGRAM	2
REFRIGERANT SYSTEM DIAGRAM	4
INDOOR PRINTED CIRCUIT BOARD CIRCUIT DIAGRAM	5
OUTDOOR PRINTED CIRCUIT BOARD CIRCUIT DIAGRAM	7
ERROR CONTENTS	8
DISASSEMBLY ILLUSTRATION	6
PARTS LIST	15

S P E C I F I C A T I O N S

INDOOR UNIT		RD-45CA	RD-45HA
OUTDOOR UNIT		ROCW-457	RO-45HA
COOLING CAPACITY	(kW)	12.4 - 12.7	12.4 - 12.7
HEATING CAPACITY	(kW)	—	13.4 - 13.7

ELECTRICAL DATA

POWER SOURCE	(V)	380 - 415		
FREQUENCY	(Hz)	50		
RUNNING CURRENT	(A)	COOLING	7.50 - 7.50	7.60 - 7.60
		HEATING	—	7.50 - 7.50
INPUT WATTS	(kW)	COOLING	4.45 - 4.57	4.45 - 4.57
		HEATING	—	4.25 - 4.35
E.E.R.	(kW/kW)	COOLING	2.79 - 2.78	2.79 - 2.78
		HEATING	—	3.15 - 3.15
MOISTURE REMOVAL	(ℓ/hr)	6.0	4.5	
AIR CIRCULATION-Hi	(m³/hr)	2,200	2,200	

COMPRESSOR

TYPE	Hermetic type, 2 pole, Three phase, Induction motor, Recipro
CODE	CRPQ-0450-TFD

FAN MOTOR

INDOOR UNIT	TYPE	MFA-45BTT		
	HI-SPEED	(r.p.m.)	1,320	
	MED-SPEED	(r.p.m.)	1,270	
	LO-SPEED	(r.p.m.)	1,200	
OUTDOOR UNIT	TYPE	MFB-362FT		
	HI-SPEED	(r.p.m.)	790	790
	LO-SPEED	(r.p.m.)	510	—

DIMENSIONS

INDOOR	H x W x D (mm)	270 x 1,210 x 700
OUTDOOR	H x W x D (mm)	1,152 x 940 x 370

WEIGHT

GROSS WEIGHT	GROSS / NET (kg)	60 / 45	
NET WEIGHT	GROSS / NET (kg)	116 / 112	122 / 108

REFRIGERANT CHARGE (R-22)

MODELS		PIPE LENGTH					
		5 m (16 ft)	10 m (33 ft)	20 m (66 ft)	30 m (99 ft)	40 m (132 ft)	50 m (164 ft)
FULL CHARGE AMOUNT	RD-45CA	3,150 g (111.1 oz)			3,550 g (125.2 oz)	3,950 g (139.3 oz)	4,350 g (153.4 oz)
	RD-45HA	3,400 g (119.9 oz)			3,800 g (134.0 oz)	4,200 g (148.2 oz)	4,600 g (162.3 oz)

Notes : • Between 5 m and 50 m, when using a connection pipe other than that in the table, charge additional refrigerant with 40 g (1.41oz) / 1 m (3.3 ft) as the criteria.

• The above list shows values at the external static pressure of 10 mm Aq (98 Pa).

C I R C U I T D I A G R A M

Model : RD-45CA

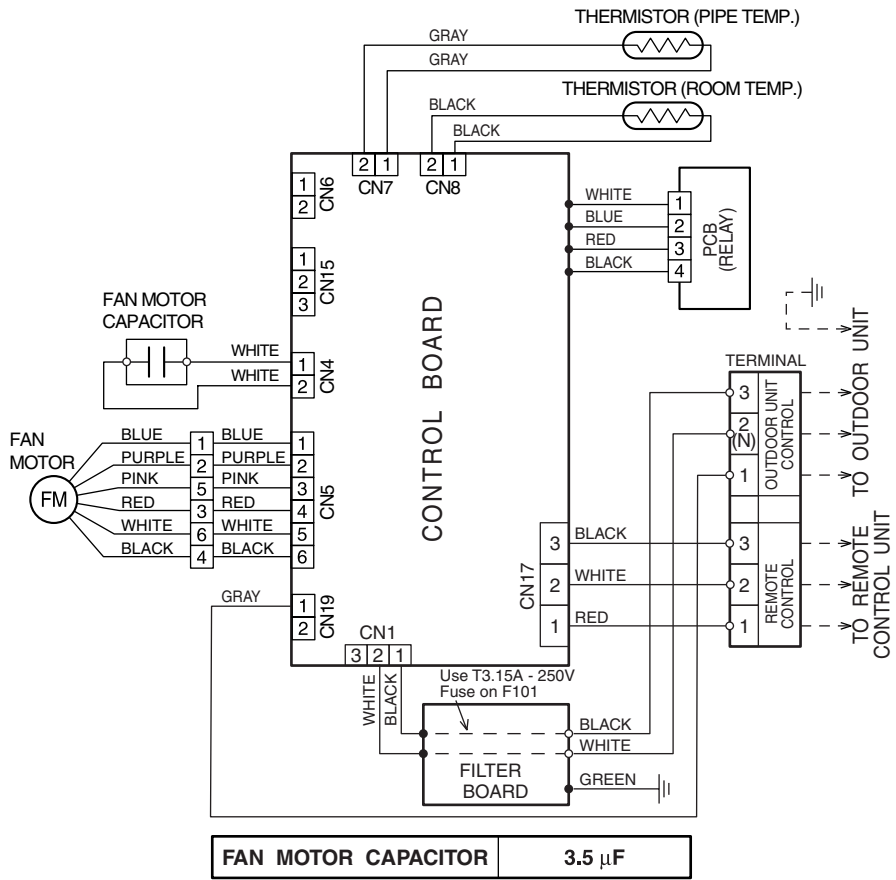

Model : ROCW-457

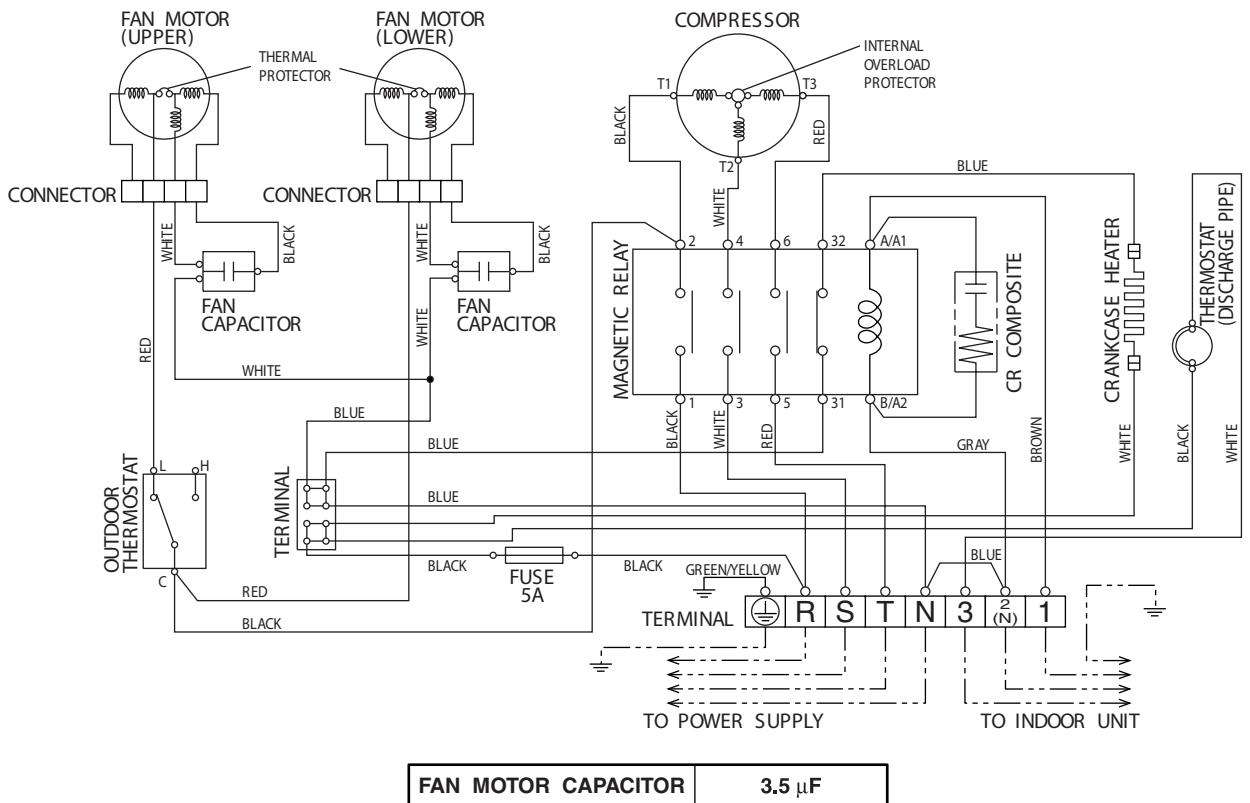

Model : RD-45HA

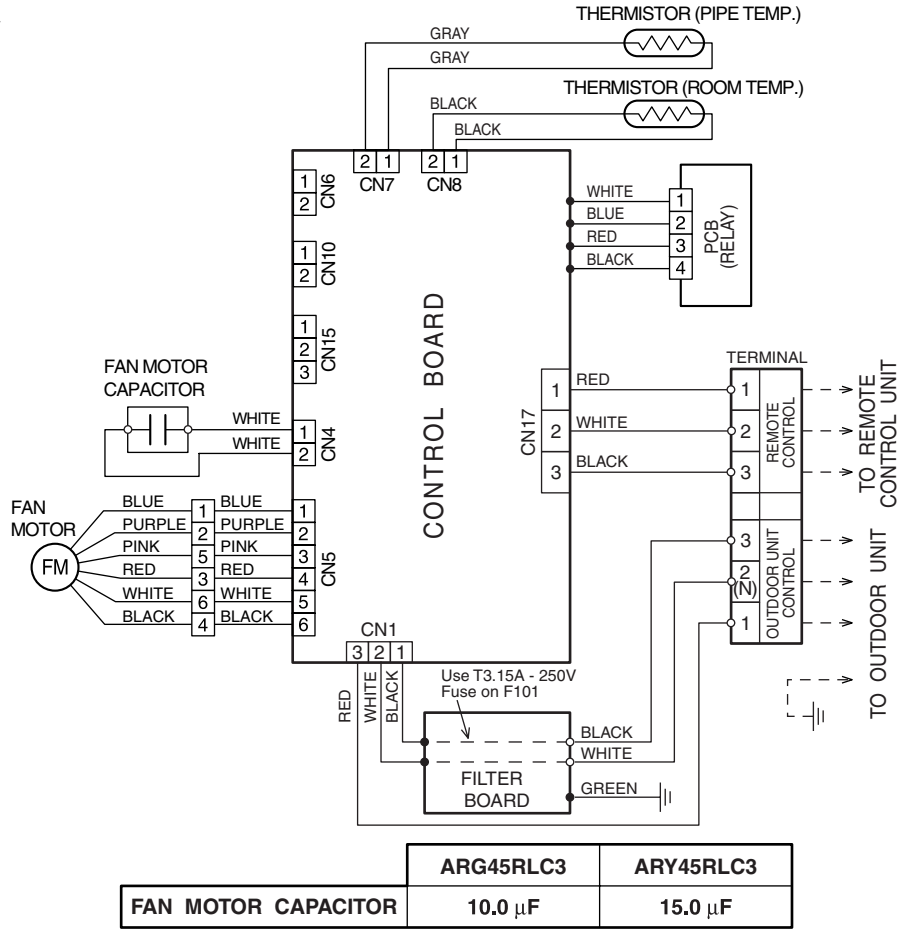

Model : RO-45HA

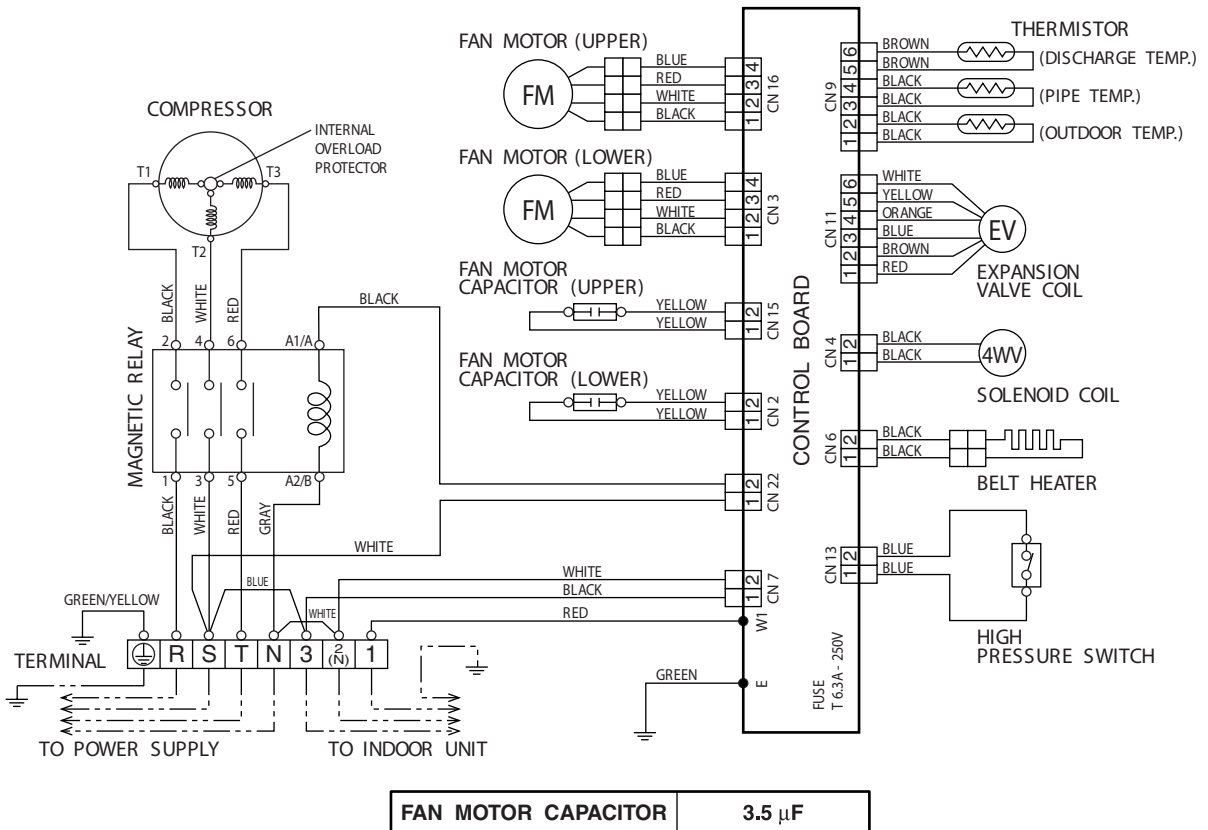

REFRIGERANT SYSTEM DIAGRAM

Model : RD-45CA / ROCW-457

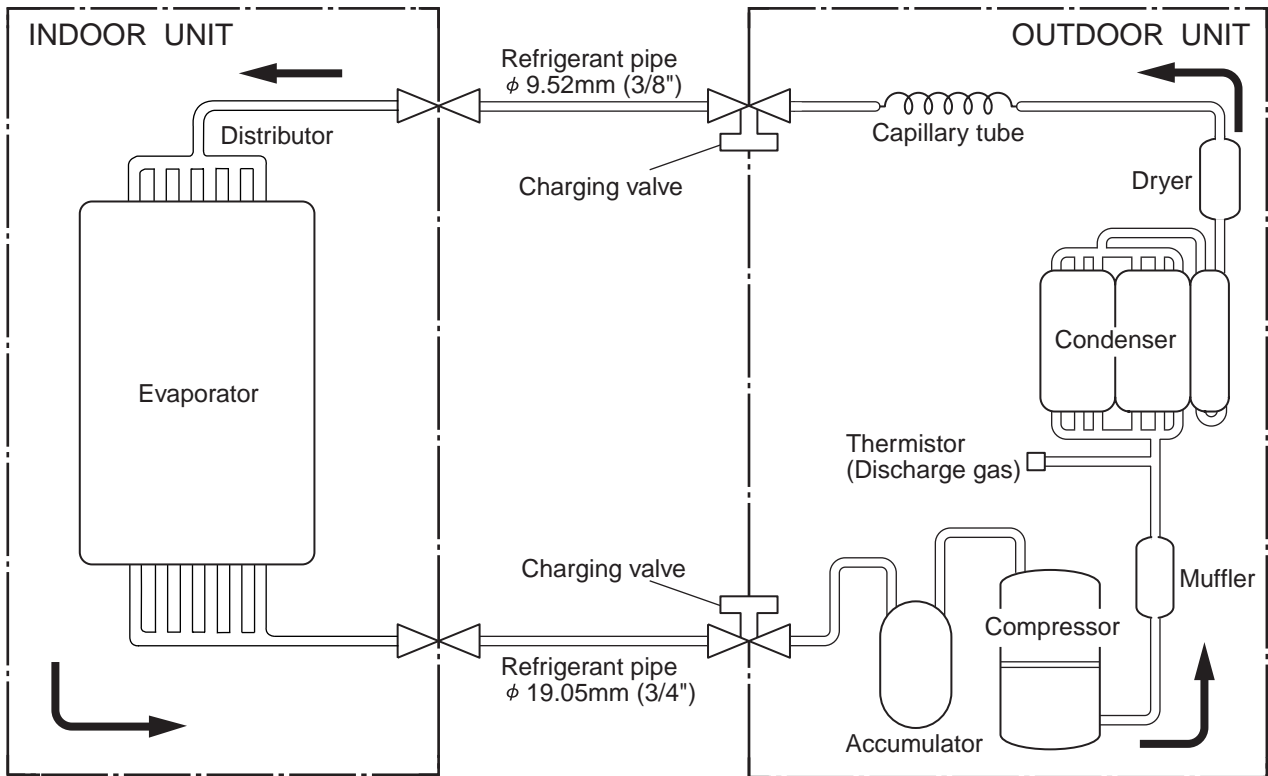

Model : RD-45HA / RO-45HA

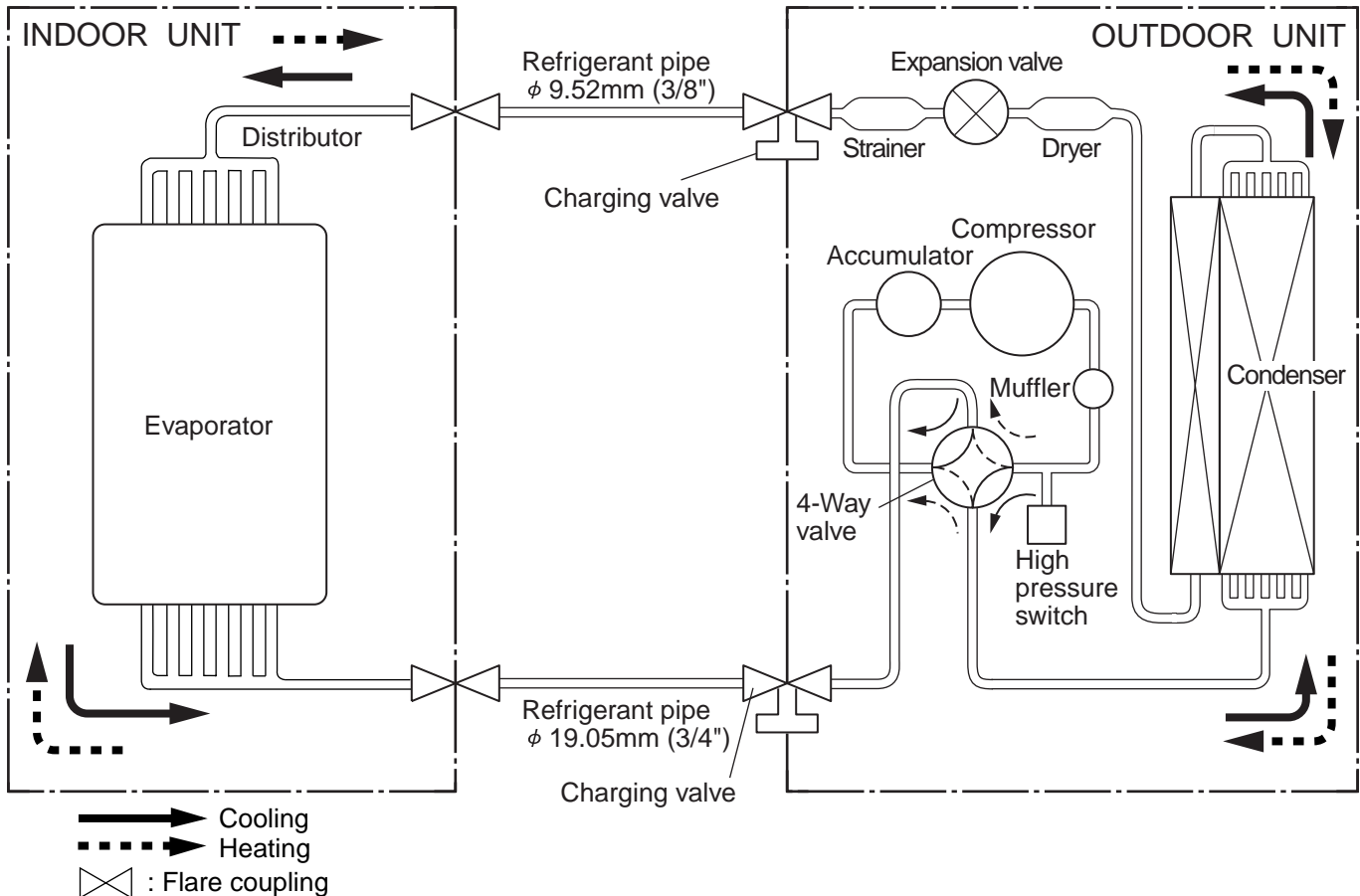

INDOOR PRINTED CIRCUIT BOARD CIRCUIT DIAGRAM

CONTROLLERPCB ASSEMBLY (MAIN PCB) EZ-002EWSE-C

Model : RD-45CA

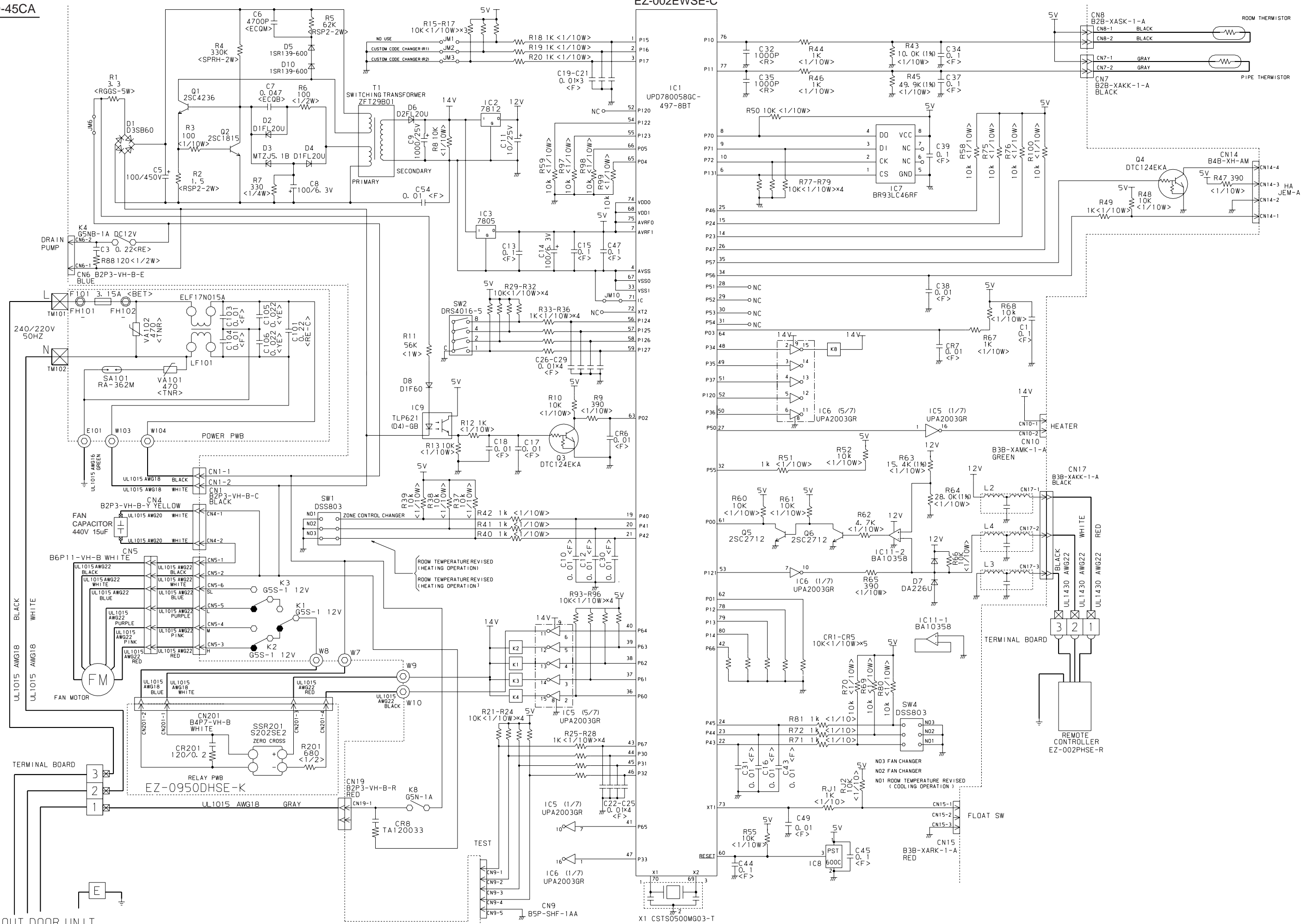

Model : RD-45RA

CONTROLLER PCB ASSEMBLY (MAIN PCB) EZ-002PHSE-C

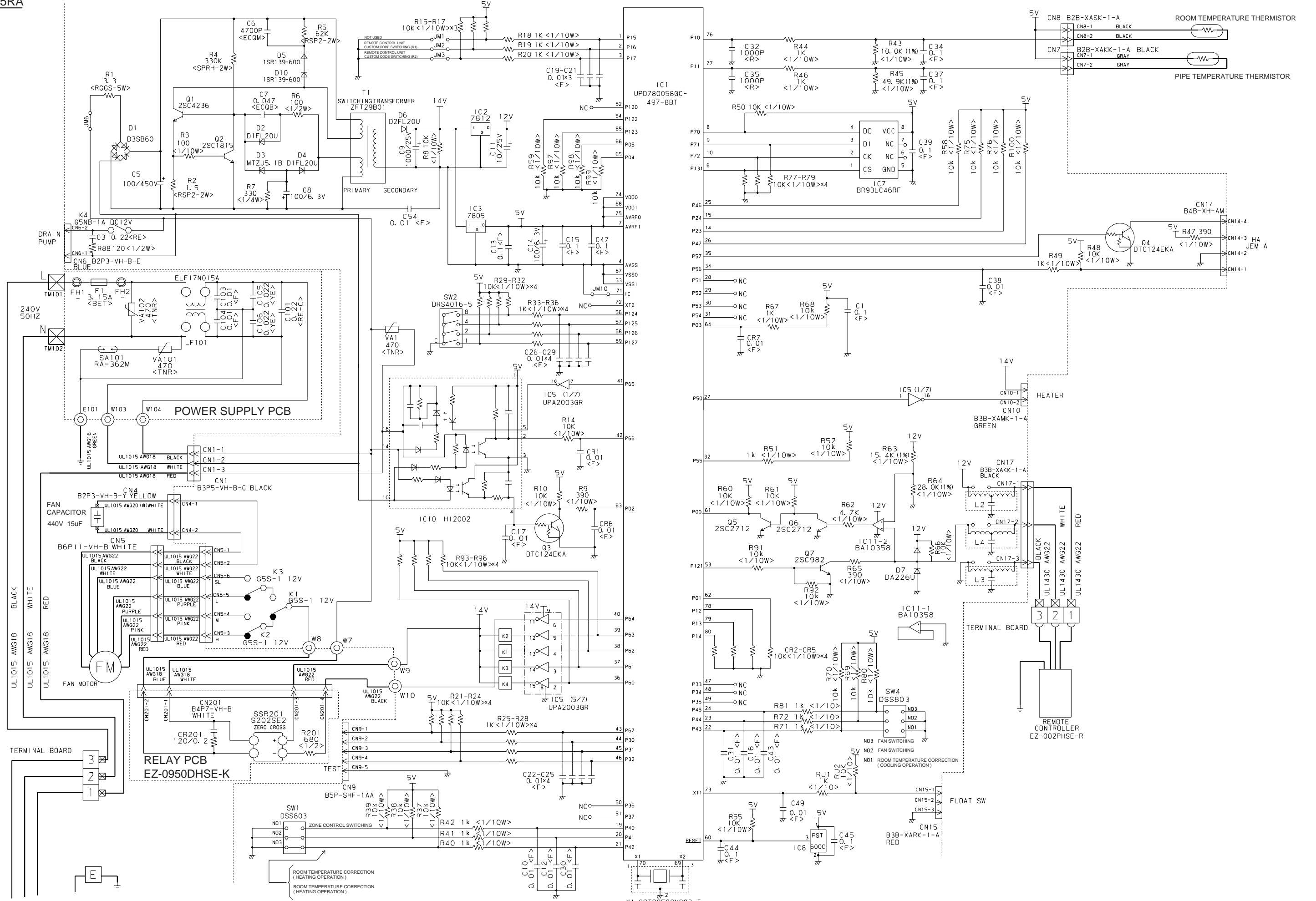

OUT DOOR UNIT

2003.06.20

OUTDOOR PRINTED CIRCUIT BOARD CIRCUIT DIAGRAM

Model : RO-45HA

CONTROLLER PCB ASSEMBLY (MAIN PCB) EZ-002MHUE-C

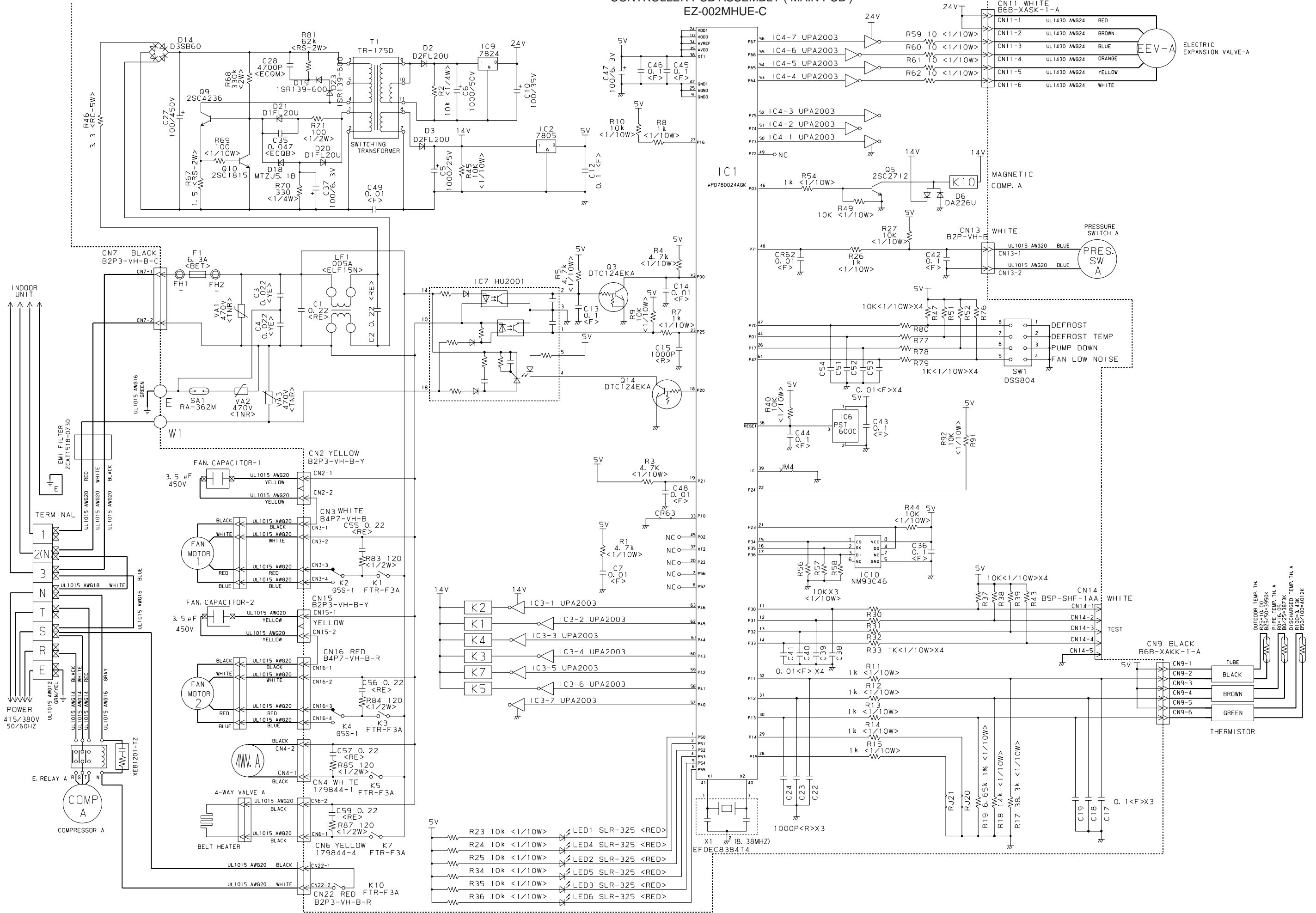

1. REMOTE CONTROLLER

When EE : EE blinks at the current time display, there is an error inside the air conditioner. If the SET TIME button (▼) and TEMP./DAY button (▼) are pressed simultaneously for more than three seconds, the self diagnosis check will start and the error contents will be displayed at the current time display. When the operation lamp lights, press the START/STOP button and after operation lamp goes off, perform the same operation. Process the error contents by referring to (Table 1).

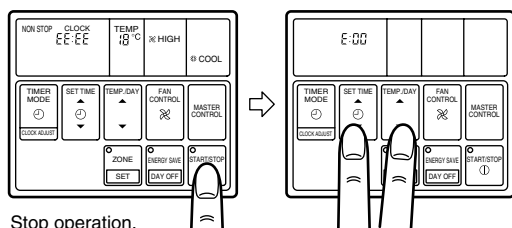

Stop operation.

Table 1

Error cord	Error contents
E:00	Communication error (indoor unit ↔ remote controller)
E:01	Communication error (indoor unit ↔ outdoor unit)
E:02	Room temperature sensor open
E:03	Room temperature sensor shortcircuited
E:04	Indoor heat exchanger temperature sensor open
E:05	Indoor heat exchanger temperature sensor shortcircuited
E:06	Outdoor heat exchanger temperature sensor open
E:07	Outdoor heat exchanger temperature sensor shortcircuited
E:08	Power source connection error
E:09	Float switch operated
E:0A	Outdoor temperature sensor open
E:0B	Outdoor temperature sensor shortcircuited
E:0C	Discharge pipe temperature sensor open
E:0D	Discharge pipe temperature sensor shortcircuited
E:0E	Outdoor high pressure abnormal
E:0F	Discharge pipe temperature abnormal
E:11	Model abnormal
E:12	Indoor fan abnormal
E:13	Outdoor signal abnormal
E:14	Outdoor EEPROM abnormal

To stop test running, press the START/STOP button.

For the operation method, refer to the operating manual and perform operation check.

Check that there are no abnormal sounds or vibration sounds during test running.

2. OUTDOOR UNIT

When the outdoor temperature drops, the outdoor unit's fans may switch to low speed, or one of the fans may stop intermittently.

ERROR : Heat & Cool model (Reverse cycle) only

The LED lamps operate as follows (Table 2) according to the error contents.

The LED lamps are on the outdoor unit board.

Table 2

Error contents	LED1	LED2	LED3	LED4	LED5	LED6
Signal abnormal	–	–	X	○	X	X
Indoor unit abnormal	–	–	X	X	○	X
Discharge pipe temperature abnormal	–	–	X	X	X	○
Outdoor heat exchanger temperature abnormal	–	–	X	X	○	○
Outdoor temperature abnormal	–	–	X	○	X	○
Power source connection error	–	–	○	X	X	X
EEPROM abnormal	–	–	○	○	○	○
	◎	◎	◎	◎	◎	◎
Outdoor high pressure abnormal	○	–	–	–	–	–
Discharge pipe temperature abnormal	–	○	–	–	–	–

○ : 0.5s ON / 0.5s OFF (flash) X : OFF

◎ : 0.1s ON / 0.1s OFF (flash) – : Indefinite

When the fault is cleared, the LED lamp goes off.

However, for discharge pipe temperature abnormal and high pressure abnormal, the LED lamp lights continuously for 24 hours, as long as the power is not turned off.

ERROR LED DISPLAY LAYOUT

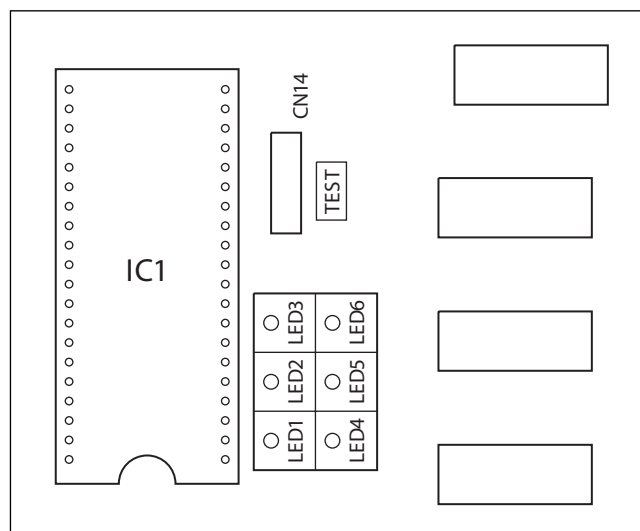

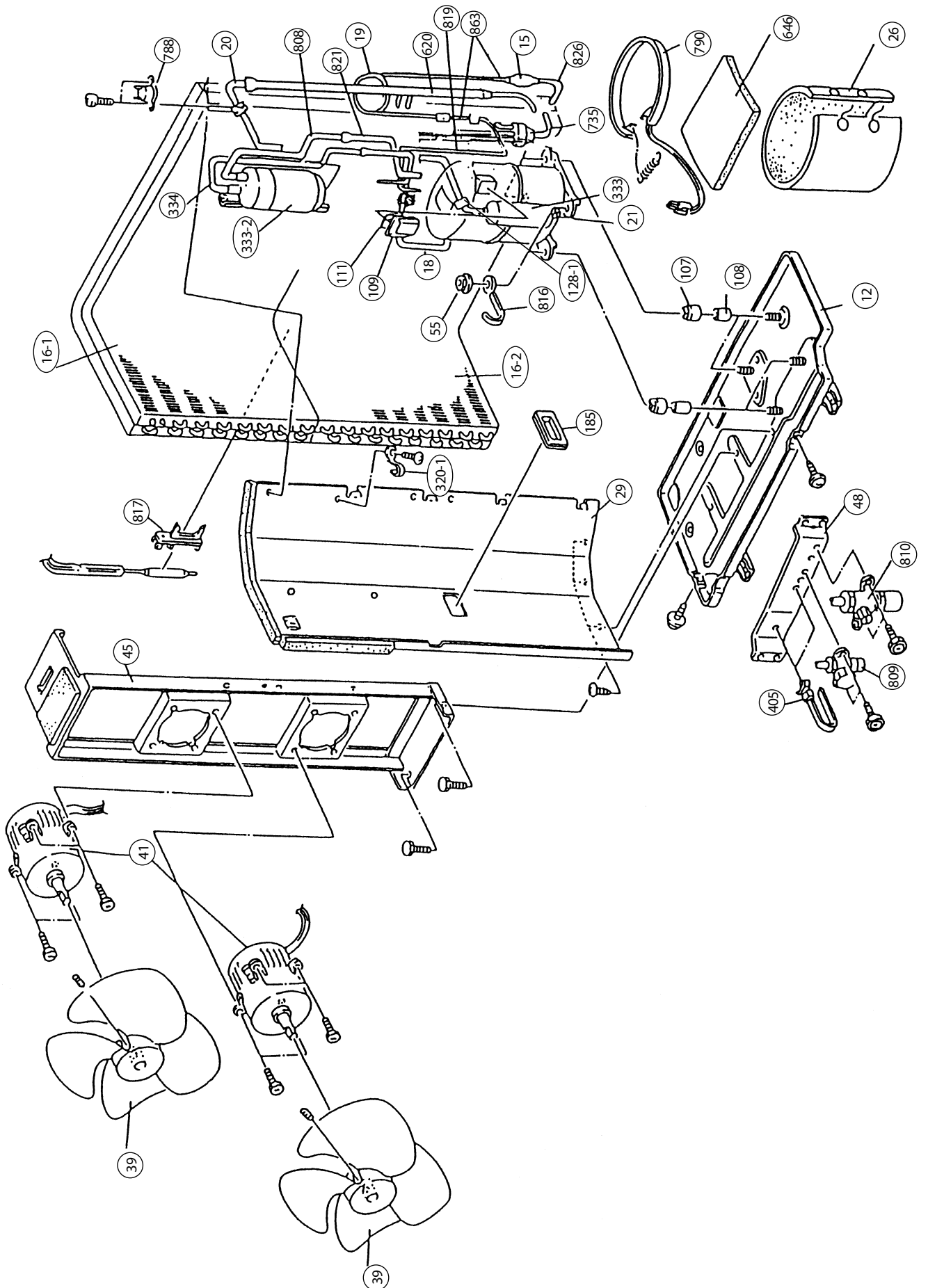

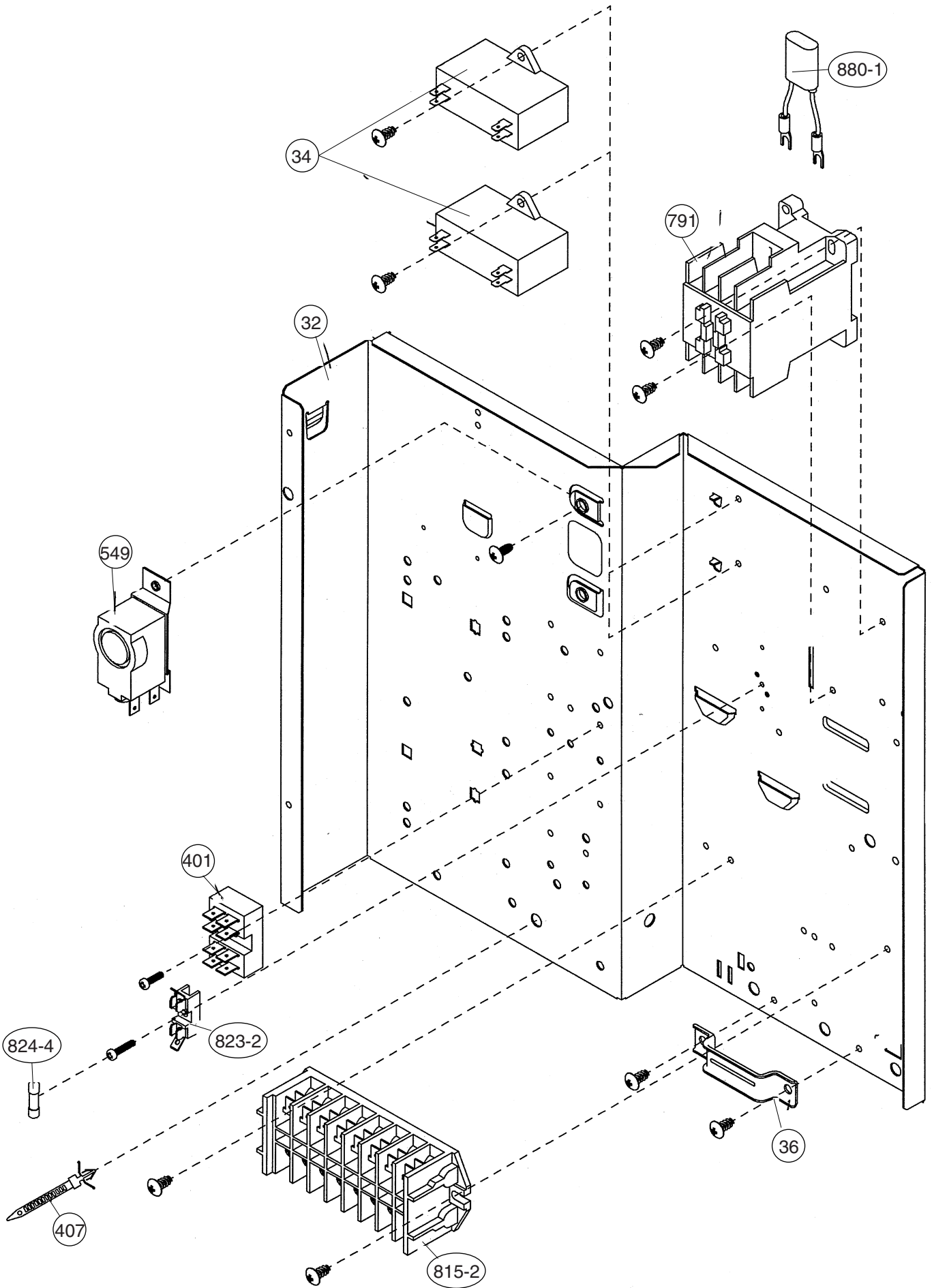

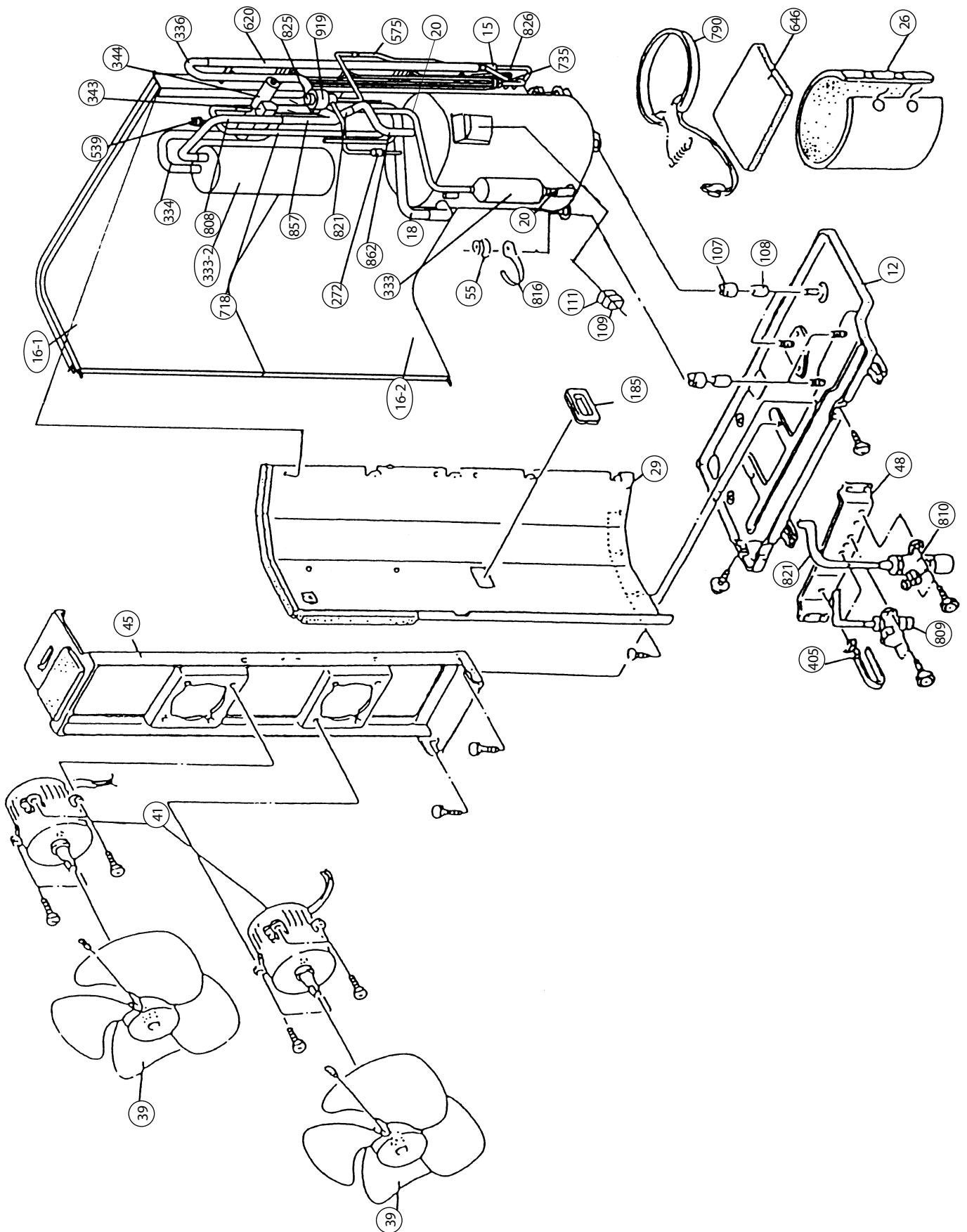

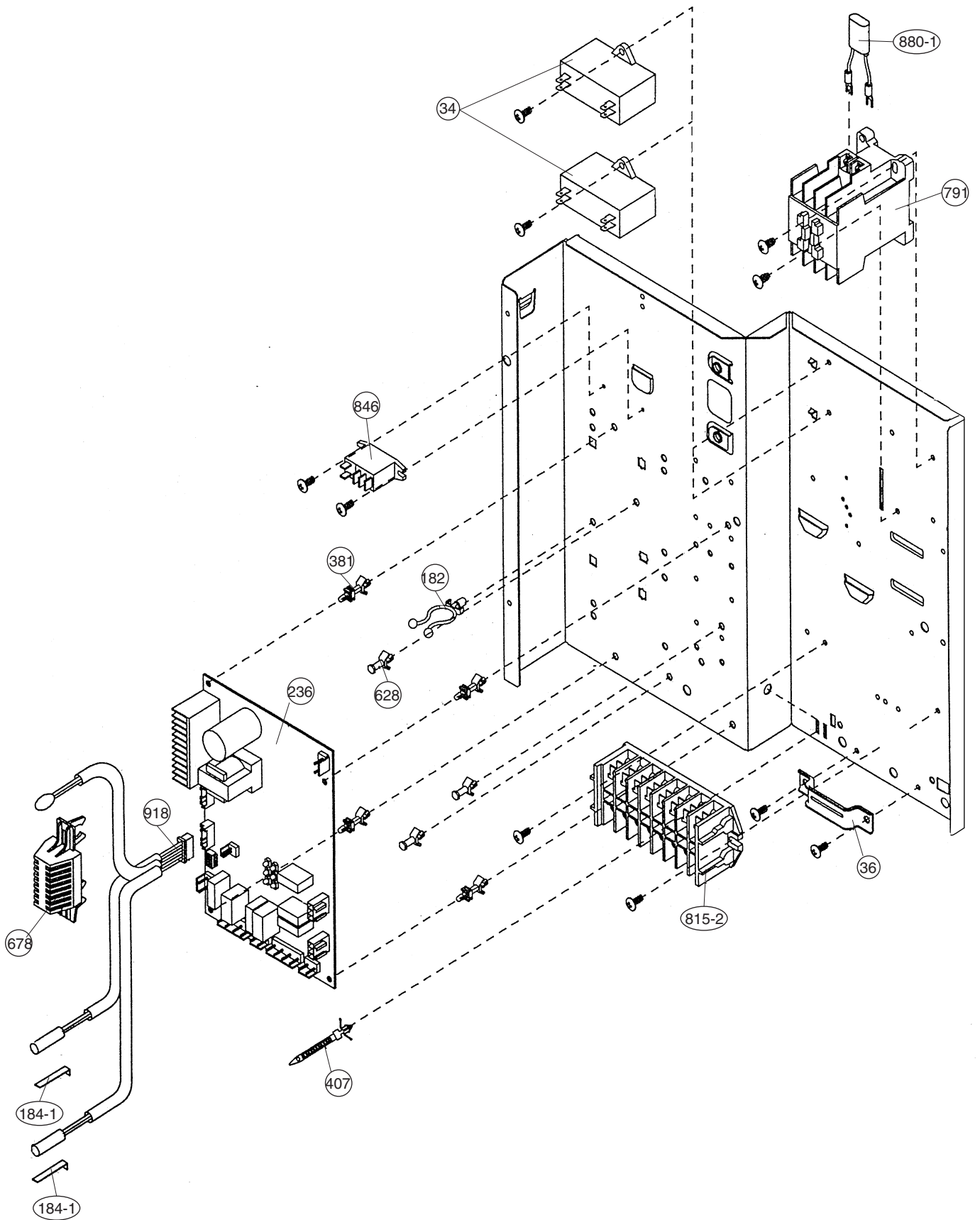

Models : RD-45CA
RD-45HA

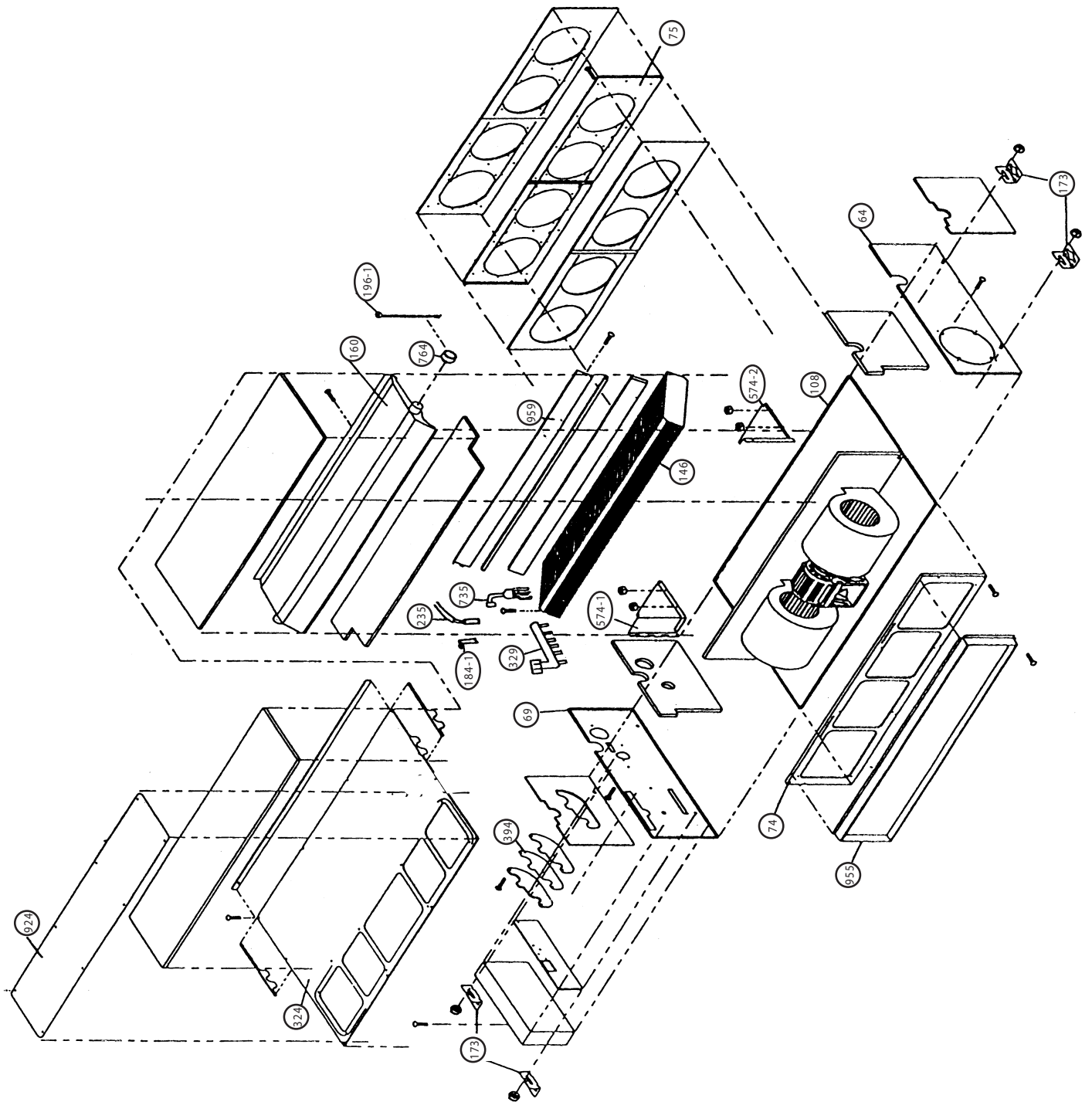

Models : RD-45CA
RD-45HA

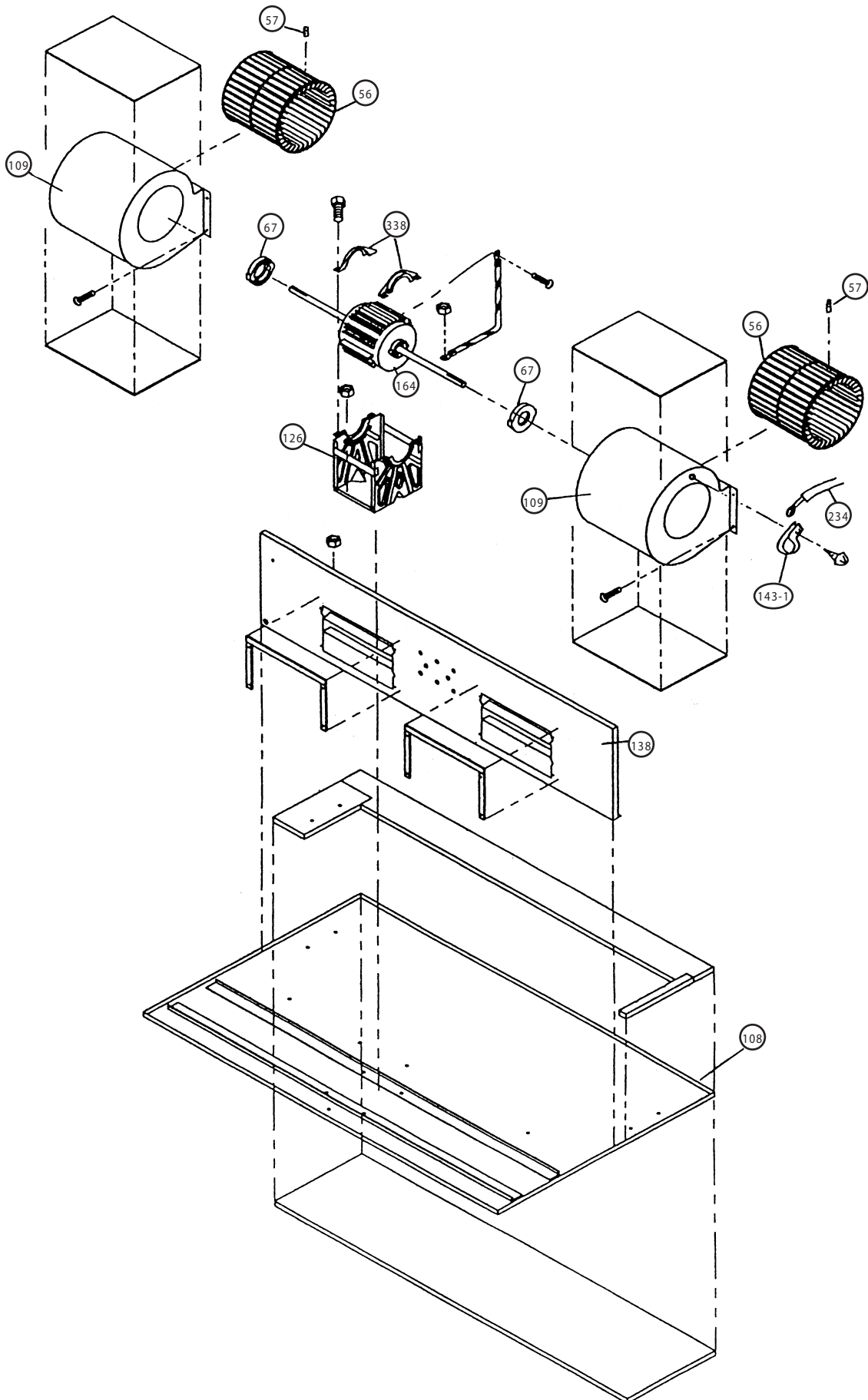

Models : RD-45CA
RD-45HA

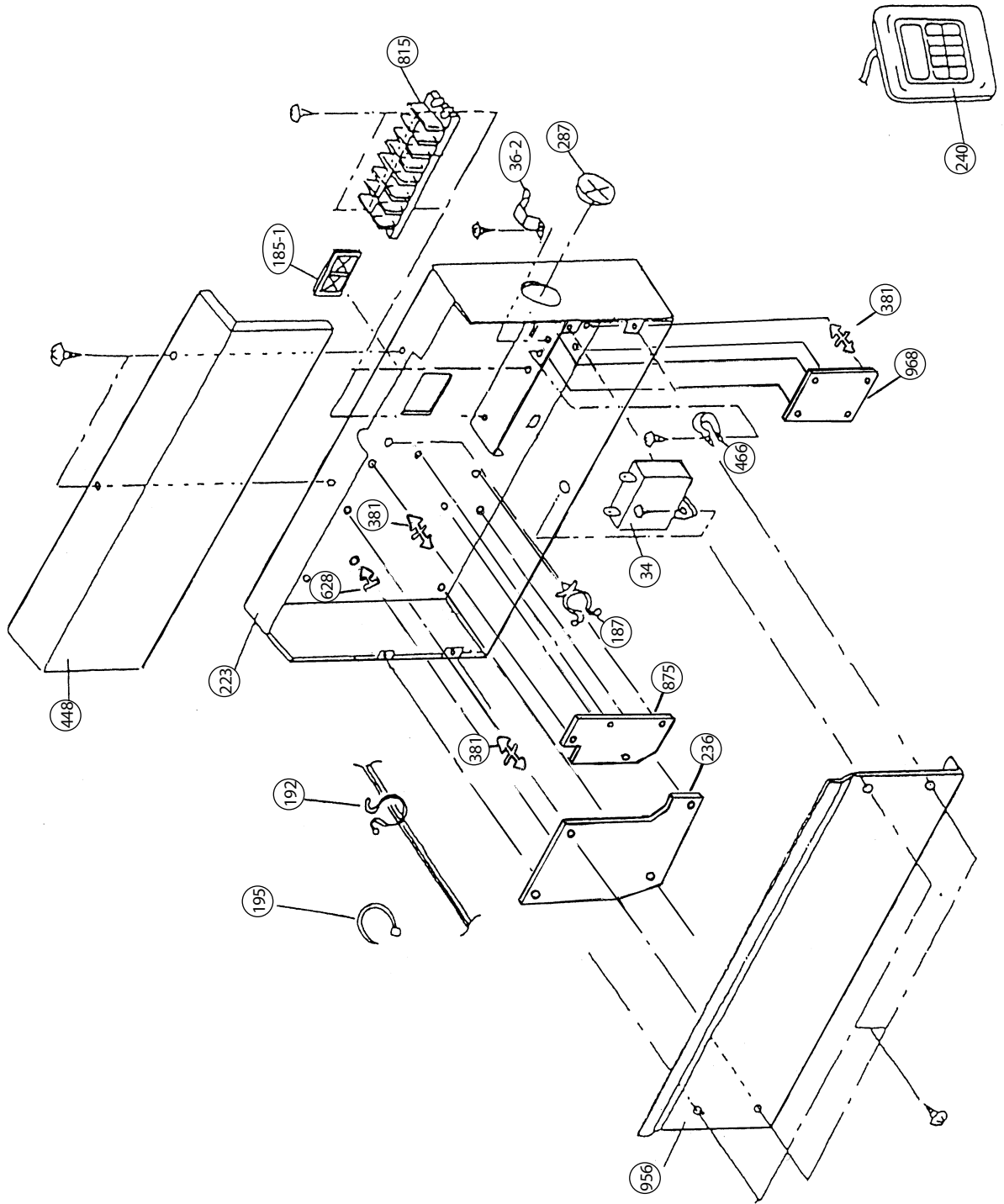

PARTS LIST

When you order parts, please make a photocopy of this page and fill the number of the parts in the "Order" column.

INDOOR UNIT

Ref. No.	Description	Part No.		Ord. Qty	Ref. No.	Description	Part No.		Ord. Qty
		RD-45CA	RD-45HA				RD-45CA	RD-45HA	
34	Capacitor (Fan Motor)	9704305053	9704305053		234	Thermistor Assy-Room	9703299056	9703299056	
36-2	Cord Holder Metal	9356362008	9356362008		235	Thermistor Assy-Pipe	9703297045	9703297045	
56	Sirocco Fan Assy	9356531022	9356531022		236	Controller PCB Assy	9704557049	9704557049	
57	Hex. Socket Screw	313616213202	313616213202		240	Remote Control Unit	9703173066	9371438030	
64	Cabinet-Left Metal	9356551006	9356551006		287	Cap (Power)	9352173011	9352173011	
67	Rubber (Vibration-proof)	313659068604	313659068604		324	Top Plate	9356546002	9356546002	
69	Cabinet-Right Metal	9356547009	9356547009		329	Coupling Pipe Assy	9357005003	9357005003	
74	Intake Panel	9356537000	9356537000		338	Motor Fixture	9356536003	9356536003	
75	Outlet Panel Assy	9356538007	9356538007		381	Locking Spacer	313209391506	313209391506	
108	Base Assy	9356518009	9356518009		394	Pipe Fixing Plate	9356554007	9356554007	
109	Casing Assy	9356527001	9356527001		448	Control Box Metal-B	9356560008	9356560008	
126	Motor Fixing Table Assy	9356533002	9356533002		466	Clamp NK-4N	313714328805	313714328805	
138	Separate Wall	9356523003	9356523003		574-1	Eva. Fixing Plate-R	9356521009	9356521009	
143-1	Clamp NK-3N	313361274700	313361274700		574-2	Eva. Fixing Plate-L	9356522006	9356522006	
146	Evaporator Assy	9356524017	9356524017		628	Locking Spacer	313005446558	313005446558	
160	Drain Pan Assy	9356542028	9356542028		735	Distributor Assy	9357004006	9357004006	
164	Fan Motor Assy-IN	9600830017	9600830017		764	Drain Cap	9356541007	9356541007	
173	Hanger Bracket	9356563009	9356563009		815	Terminal-7P	9703403019	9703403019	
184-1	Thermo. SpringDA	313728262708	313728262708		875	Filter PCB Assy	9703171024	9703171017	
185-1	Rubber Bushing	9357376004	9357376004		924	Intake Seal Plate	9356553000	9356553000	
187	Clamp No.1219	313361271706	313361271706		955	Square Flange Assy	9356555004	9356555004	
192	Clamp No.062	313361271402	313361271402		956	Control Box Metal-E	9356900002	9356900002	
195	Clamp SKB-100	313361275805	313361275805		959	Eva. Seal Plate	9356540000	9356540000	
196-1	Clamp SKB-3M	312300787605	312300787605		968	Relay PCB Assy	9701594030	9701594030	
223	Control Box Metal Assy	9356558005	9356558005						

OUTDOOR UNIT

When you order parts, please make a photocopy of this page and fill the number of the parts in the "Order" column.

Ref. No.	Description	Part No.		Ord. Qty
		ROCW-457	RO-45HA	
2	Fan Cover	9352159015	9352159015	
4	Emblem-Rear	9361328006	9361328006	
5	Cabinet-A, Painted	9352146015	9352146015	
6	Cabinet-C, Painted	9352149016	9352149016	
9	Cabinet-B, Painted	9352147012	9352147012	
12	Base Assy, Painted	9352136016	9352136016	
15	Dryer	9368111014	9368111014	
16-1	Condenser-A Assy	9369544002	9355338011	
16-2	Condenser-B Assy	9369545009	9353363008	
18	Suction Pipe	9353200006	9353200006	
19	Capillary Tube	9353644008	—	
20	Discharge Pipe Assy	9353620002	9357359007	
21	Discharge Pipe-B	9353209009	9353209009	
26	Compressor Cover-A	9353367006	9353367006	
29	Separate Wall	9355277013	9355277013	
30	Blower Cover, Painted	9352151019	9352151019	
32	Control Box Metal	9352134012	9352134012	
34	Capacitor (Fan Motor)	9357965024	9357965024	
36	Cord Holder Metal	9356934007	9356934007	
39	Propeller Fan Assy	9300855013	9300855013	
41	Fan Motor Assy-Out	9600832028	9600832028	
45	Bracket (Motor) Assy	9352141003	9352141003	
46	Compressor Assy	9353157003	9353157003	
48	Bracket (Coupler) Assy	9355281010	9355281010	
55	Special Nut M8 (For Comp.)	9355091008	9355091008	
107	Rubber Seat-A (For Comp.)	9351875039	9351875039	
108	Sleeve-A (For Comp.)	9351875046	9351875046	
109	Terminal Cover (For Comp.)	9351875053	9353360007	
111	Terminal Packing (For Comp.)	9351875060	9353361004	
128-1	Rubber (Discharge Pipe)	313155086308	—	
178-2	Capillary Holder Rubber	313394274808	313394274808	
182	Clamp No.249	—	313361271505	
184-1	Thermistor Spring A	—	313728262708	
185	Rubber Bushing	313005066051	313005066051	
236	Controller PCB Assy	—	9704764072	
272	Strainer	—	9354139008	
320-1	Wire Clamp Metal	313483219905	—	
330	Inlet Pipe (Condenser)-A	—	9353310002	
333	Accumulator	9350363018	9350363018	
333-2	Accumulator Assy (B)	9301942019	9362425001	
334	Suction Pipe-B	9352287008	9352287008	
343	Solenoid Coil	—	9359616108	
344	4-Way Valve	—	9353532008	
373	Grip	9352157004	9352157004	
381	Locking Spacer	—	313209391506	
405	Clamp No. 1763	313816345304	313816345304	
407	Clamp (Cable) No. 1259	313739340109	313739340109	
527	Protection Net	9352163012	9352163012	
539	Pressure Switch	—	9355094009	
549	Thermostat-Outdoor	9352426001	—	
575	Condensing Pipe-C	—	9363460001	
620	Inlet Pipe (Cond.) Assy	9353183002	9353183002	
628	Locking Spacer-B	—	313005446558	
646	Compressor Cover-B	9353368003	9353368003	
678	Bracket (Thermistor)	—	313557406106	
718	Discharge Pipe-C	—	9363761009	
734	Cabinet Top Plate	9352161018	9352161018	
735	Distributor Assy	9353187000	9353187000	
788	Thermostat-Overheat	9354061002	—	











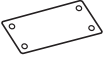

When you order parts, please make a photocopy of this page and fill the number of the parts in the "Order" column.

OUTDOOR UNIT (Continued)



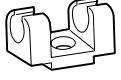







Ref. No.	Description	Part No.		Ord. Qty
		ROCW-457	RO-45HA	
788	Thermistor-Discharge	—	9358337028	
790	Belt Heater	—	9361140028	
791	Magnetic Relay	9363277005	9363277005	
803	Cabinet-D, Painted	9352150012	9352150012	
805	Blower Cover Corner	9352160011	9352160011	
808	Inlet Pipe (Accumulator)	9352556005	9363458008	
809	Ball Valve-A	9357976006	9357976006	
810	Ball Valve-B	9357982007	9357982007	
813	Cabinet Hook	9352148002	9352148002	
815-2	Terminal 8P	9363276022	9363276022	
816	Wire Clamp Metal	313584219902	313584219902	
817	Thermostat Fixture	9352164019	—	
819	Joint Pipe (Valve-A)	9353621009	9363457001	
821	Joint Pipe (Valve-B) Assy	9352284007	9353307002	
822	Fan Cover Fixture-A	9352158018	9352158018	
823-2	Fuse Holder	0500063024	—	
824-4	Fuse	0600222529	—	
825	Expansion Valve Assy	—	9363453003	
826	Condensing Pipe-B	9353215000	9353215000	
846	Relay	—	9703887017	
857	Inlet Pipe (Accumulator)-B	—	9363459005	
862	Valve-B Couple. Pipe	—	9353309006	
863	Joint Pipe (Capillary)-B	9353206008	—	
880-1	Network	9700987017	9700987017	
918	Thermistor Assy	—	9900129019	
919	Coil (Expansion Valve)	—	9363467017	

STANDARD ACCESSORIES

INDOOR UNIT ACCESSORIES

Name and Shape	Q'ty	Application	Parts No.	
			RD-45CA	RD-45HA
Installation template 	1	For positioning the indoor unit	9357036007	9357036007
Hanger 	4	For suspending the indoor unit from ceiling	9356563009	9356563009
Special nut A (large flange) 	4	For suspending the indoor unit from ceiling	313005446653	313005446653
Special nut B (small flange) 	4		313005446759	313005446759
Coupler heat insulation (large) 	2	For indoor side pipe joint (large pipe)	9350716029	9350716029
Coupler heat insulation (small) 	1	For indoor side pipe joint (small pipe)	9352766015	9352766015
Nylon fastener 	1	For fixing the drain hose	312300787605	312300787605
Remote control unit 	1		9703173066	9371438030
Remote control unit cord clamp 	10	For installing the remote controller cord	313714181904	313714181904
Tapping screw (flush heads) 	10	For installing the remote control unit cord clamp	301141153027	301141153027
Auxiliary pipe assembly 	1	For wiring conduit (gas side) connection	9357038001	9357038001
Drain hose insulation 	1	Insulates the drain hose and vinyl hose connection	313806217708	313806217708

OUTDOOR UNIT ACCESSORIES

Name and Shape	Q'ty	Application	Parts No.	
			ROCW-457	RO-45HA
Power cap 	1	For power cord installation	9352173011	9352173011
Auxiliary pipe assembly 	1	For wiring conduit (gas side) connection (May not be supplied, depending on the model)	9355292016	9355292016
Edge cover 	1	For wiring conduit installation hole edge protection	9352436000	9352436000
Tapping screw 	2	For cabinet A and cabinet D mounting (1) Spare (1)	301463040100	301463040100
Binder 	1	For power cord binding	313035356905	313035356905
Putty 	1	For sealing	303020200114	303020200114
Coupler heat insulation 	1	For outdoor side pipe joint	313005074759	313005074759
Pipe (drain) 	2	For outdoor unit drain piping work	313728031005	313728031005
Flexible tube 	2		313013042915	313013042915
Cap (drain) 	2		313166024302	313166024302



MANUFACTURER :

Fuji Denki Sosetsu Co., Ltd.

Tokyo, Japan