

# INSTALLATION MANUAL

(PART NO. 9312365036-01)

## This air conditioner uses new refrigerant HFC (R410A).

The basic installation work procedures are the same as conventional refrigerant (R22) models. However, pay careful attention to the following points:

- Since the working pressure is 1.6 times higher than that of conventional refrigerant(R22) models, some of the piping and installation and service tools are special.(See the table below.) Especially, when replacing a conventional refrigerant(R22) model with a new refrigerant R410A model, always replace the conventional piping and flare nuts with the R410A piping and flare nuts.
- Models that use refrigerant R410A have a different charging port thread diameter to prevent erroneous charging with conventional refrigerant(R22) and for safety. Therefore, check beforehand.[The charging port thread diameter for R410A is 1/2 threads per inch.]
- Be more careful that foreign matter (oil, water, etc.) does not enter the piping than with refrigerant (R22) models. Also, when storing the piping ,securely seal the opening by pinching ,taping, etc.
- When charging the refrigerant, take into account the slight change in the composition of the gas and liquid phases, and always charge from the liquid phase side whose composition is stable.

## Special tools for R410A

Tool name	Contents of change
Gauge manifold	Pressure is high and cannot be measured with a conventional gauge. To prevent erroneous mixing of other refrigerants, the diameter of each port has been changed. It is recommended the gauge with seals-0.1 to 5.3 MPa (-1 to 53 bar) for high pressure. -0.1 to 3.8 MPa (-1 to 38 bar) for low pressure.
Charge hose	To increase pressure resistance, the hose material and base size were changed.
Vacuum pump	A conventional vacuum pump can be used by installing a vacuum pump adapter.
Gas leakage detector	Special gas leakage detector for HFC refrigerant R410A.

## Copper pipes

It is necessary to use seamless copper pipes and it is desirable that the amount of residual oil is less than 40 mg/10m. Do not use copper pipes having a collapsed, deformed or discolored portion (especially on the interior surface). Otherwise, the expansion valve or capillary tube may become blocked with contaminants.

As an air conditioner using R410A incurs pressure higher than when using R22, it is necessary to choose adequate materials. Thicknesses of copper pipes used with R410A are as shown in Table1.Never use copper pipes thinner than 0.8mm even when it is available on the market.

Table 1 Thicknesses of Annealed Copper Pipes

Nominal diameter	Outer diameter (mm)	Thickness (mm)	
		R410A	[ref.] R22
1/4	6.35	0.80	0.80
1/2	12.7	0.80	0.80

## WARNING

- Do not use the existing (for R22) piping and flare nuts.
  - If the existing materials are used, the pressure inside the refrigerant cycle will rise and cause breakage, injury, etc.(Use the special R410A materials.)
- When installing and relocating the air conditioner, do not mix gases other than the specified refrigerant(R410A) to enter the refrigerant cycle.
  - If air or other gas enters the refrigerant cycle, the pressure inside the cycle will rise to an abnormally high value and cause breakage, injury, etc.

## SELECTING THE MOUNTING POSITION

Decide the mounting position with the customer as follows:

- INDOOR UNIT**
  - Install the indoor unit level on a strong wall which is not subject to vibration.
  - The inlet and outlet ports should not be obstructed : the air should be able to blow all over the room.
  - Install the unit near an electric outlet or special branch circuit.
  - Do not install the unit where it will be exposed to direct sunlight.
  - Install the unit where connection to the outdoor unit is easy.
  - Install the unit where the drain pipe can be easily installed.
  - Take servicing, etc. into consideration and leave the spaces shown in (Fig. 2). Also install the unit where the filter can be removed.
- OUTDOOR UNIT**
  - If possible, do not install the unit where it will be exposed to direct sunlight. (If necessary, install a blind that does not interfere with the air flow.)
  - Do not install the unit where a strong wind blows or where it is very dusty.
  - Do not install the unit where people pass.
  - Take you neighbors into consideration so that they are not disturbed by air blowing into their windows or by noise.
  - Provide the space shown in Fig. 2 so that the air flow is not blocked. Also for efficient operation, leave open three of the four directions front, rear, and both sides.

## INSTALLATION DIAGRAM OF INDOOR AND OUTDOOR UNITS

Fig. 2

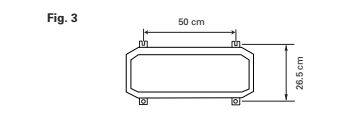
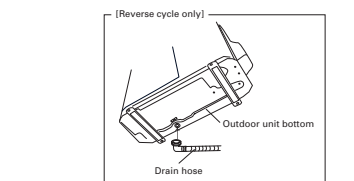
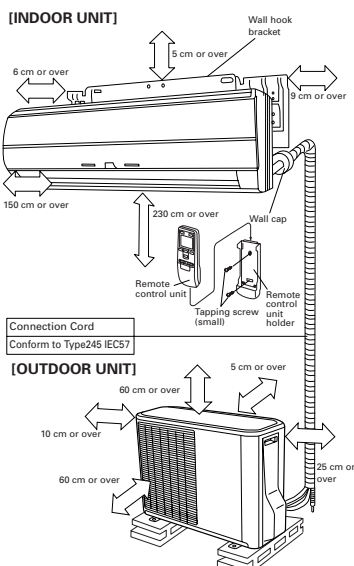

**WARNING**  
Install at a place that can withstand the weight of the indoor and outdoor units and install positively so that the units will not topple or fall.

**CAUTION**  
(1) Do not install where there is the danger of combustible gas leakage.  
(2) Do not install near heat sources.  
(3) If children under 10 years old may approach the unit, take preventive measures so that they cannot reach the unit.  
(4) Install the indoor unit on the wall where the height from the floors more than 230 cm.

**Indoor unit piping direction**  
The piping can be connected in the five directions indicated by ①, ②, ③, ④, and ⑤ in (Fig. 1). When the piping is connected in direction ② or ③, cut along the piping groove in the side of the front cover with a hacksaw.  
When connecting the piping in direction ③, cut a notch in the thin wall at the front bottom of the front cover.

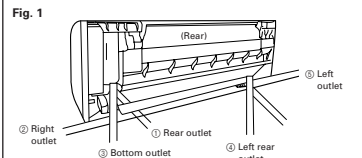

## For authorized service personnel only.

### WARNING

- For the room air conditioner to operate satisfactorily, install it as outlined in this installation manual.
- Connect the indoor unit and outdoor unit with the air conditioner piping and cords available standards parts. This installation manual describes the correct connections using the standard accessories and the parts specified in this installation manual.
- Have installation work done by authorized service personnel only.
- Never cut the power cord, lengthen or shorten the cord, or change the plug.
- Also do not use an extension cord.
- Plug in the power cord plug firmly. If the receptacle is loose, repair it before using the room air conditioner.
- Do not turn on the power until all installation work is complete.

- Be careful not to scratch the air conditioner when handling it.
- After installation, explain correct operation to the customer, using the operating manual.
- Let the customer keep this installation manual because it is used when the air conditioner is serviced or moved.
- The maximum length of the piping is 15 m. The maximum height difference of the piping is 8 m, if the units are further apart than these, correct operation can not be guaranteed.

## STANDARD ACCESSORIES

The following installation accessories are supplied. Use them as required.

Name and Shape	Q'ty	Name and Shape	Q'ty
Wall hook bracket	1	Drain pipe (Reverse cycle only)	1
Remote control unit	1	Cloth tape	1
Battery	2	Tapping screw (big)	8
Remote control unit holder	1	Tapping screw (small)	2
		Seal A	1

One set of following parts are necessary in installation of this product.

Name
Connection pipe assembly
Connection cord
Wall pipe
Decorative tape
Vinyl tape
Wall cap
Saddle
Drain hose
Tapping screws
Sealant

## ELECTRICAL REQUIREMENT

Always make the air conditioner power supply a special branch circuit and provide a special switch and receptacle. Do not extend the power cord.

## FINISHING

- Insulate between pipes.
  - For rear, right, and bottom piping, butt the connection piping insulation material against the indoor unit piping and fasten it with seal A and vinyl tape so there is no gap.
  - For left and left rear piping, butt the connection pipe heat insulation and indoor unit pipe heat insulation together and bind them with and vinyl tape so that there is no gap.
  - For left and left rear piping, wrap the area which accommodates the rear piping housing section with cloth tape.
  - For left and left rear piping, bind the connection cord to the top of the pipe with vinyl tape.
  - For left and left rear piping, bundle the piping and drain hose together by wrapping them with cloth tape over the range within which they fit into the rear piping housing section.
- Temporarily fasten the connection cord along the connection pipe with vinyl tape. (Wrap to about 1/3 the width of the part from the bottom of the pipe so that water does not enter.)
- Fasten the connection pipe to the outside wall with saddles, etc.
- Fill the gap between the outside wall pipe hole and the pipe with sealer so that rain water and wind cannot blow in.
- Fasten the drain hose to the outside wall, etc.

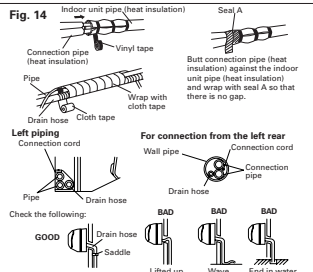
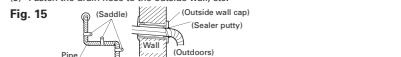

## FRONT PANEL REMOVAL AND INSTALLATION

- Open the intake grille.
- Push down the knob.
- Lift the intake grille upward, until the axle at the top of the intake grille is removed.

- Remove four screws.
- The thumb is hung on the lower part as shown in the figure, and it pulls to the front, pushing I-mark, and bottom hooks (two position) is removed from wall hook bracket.
- The front panel bottom is pulled to the front, and bottom hooks is removed indoor unit.
- The front panel is pulled to the front, raising the upper surface, and a front panel is removed.

- Remove intake grille (Reference the intake grille removal.)
- Remove four screws.
- The thumb is hung on the lower part as shown in the figure, and it pulls to the front, pushing I-mark, and bottom hooks (two position) is removed from wall hook bracket.
- The front panel bottom is pulled to the front, and bottom hooks is removed indoor unit.
- The front panel is pulled to the front, raising the upper surface, and a front panel is removed.

- Remove four screws.
- The thumb is hung on the lower part as shown in the figure, and it pulls to the front, pushing I-mark, and bottom hooks (two position) is removed from wall hook bracket.
- The front panel bottom is pulled to the front, and bottom hooks is removed indoor unit.
- The front panel is pulled to the front, raising the upper surface, and a front panel is removed.

- Remove four screws.
- The thumb is hung on the lower part as shown in the figure, and it pulls to the front, pushing I-mark, and bottom hooks (two position) is removed from wall hook bracket.
- The front panel bottom is pulled to the front, and bottom hooks is removed indoor unit.
- The front panel is pulled to the front, raising the upper surface, and a front panel is removed.

- Remove four screws.
- The thumb is hung on the lower part as shown in the figure, and it pulls to the front, pushing I-mark, and bottom hooks (two position) is removed from wall hook bracket.
- The front panel bottom is pulled to the front, and bottom hooks is removed indoor unit.
- The front panel is pulled to the front, raising the upper surface, and a front panel is removed.

- Remove four screws.
- The thumb is hung on the lower part as shown in the figure, and it pulls to the front, pushing I-mark, and bottom hooks (two position) is removed from wall hook bracket.
- The front panel bottom is pulled to the front, and bottom hooks is removed indoor unit.
- The front panel is pulled to the front, raising the upper surface, and a front panel is removed.

- Remove four screws.
- The thumb is hung on the lower part as shown in the figure, and it pulls to the front, pushing I-mark, and bottom hooks (two position) is removed from wall hook bracket.
- The front panel bottom is pulled to the front, and bottom hooks is removed indoor unit.
- The front panel is pulled to the front, raising the upper surface, and a front panel is removed.

- Remove four screws.
- The thumb is hung on the lower part as shown in the figure, and it pulls to the front, pushing I-mark, and bottom hooks (two position) is removed from wall hook bracket.
- The front panel bottom is pulled to the front, and bottom hooks is removed indoor unit.
- The front panel is pulled to the front, raising the upper surface, and a front panel is removed.

- Remove four screws.
- The thumb is hung on the lower part as shown in the figure, and it pulls to the front, pushing I-mark, and bottom hooks (two position) is removed from wall hook bracket.
- The front panel bottom is pulled to the front, and bottom hooks is removed indoor unit.
- The front panel is pulled to the front, raising the upper surface, and a front panel is removed.

- Remove four screws.
- The thumb is hung on the lower part as shown in the figure, and it pulls to the front, pushing I-mark, and bottom hooks (two position) is removed from wall hook bracket.
- The front panel bottom is pulled to the front, and bottom hooks is removed indoor unit.
- The front panel is pulled to the front, raising the upper surface, and a front panel is removed.

- Remove four screws.
- The thumb is hung on the lower part as shown in the figure, and it pulls to the front, pushing I-mark, and bottom hooks (two position) is removed from wall hook bracket.
- The front panel bottom is pulled to the front, and bottom hooks is removed indoor unit.
- The front panel is pulled to the front, raising the upper surface, and a front panel is removed.

- Remove four screws.
- The thumb is hung on the lower part as shown in the figure, and it pulls to the front, pushing I-mark, and bottom hooks (two position) is removed from wall hook bracket.
- The front panel bottom is pulled to the front, and bottom hooks is removed indoor unit.
- The front panel is pulled to the front, raising the upper surface, and a front panel is removed.

- Remove four screws.
- The thumb is hung on the lower part as shown in the figure, and it pulls to the front, pushing I-mark, and bottom hooks (two position) is removed from wall hook bracket.
- The front panel bottom is pulled to the front, and bottom hooks is removed indoor unit.
- The front panel is pulled to the front, raising the upper surface, and a front panel is removed.

- Remove four screws.
- The thumb is hung on the lower part as shown in the figure, and it pulls to the front, pushing I-mark, and bottom hooks (two position) is removed from wall hook bracket.
- The front panel bottom is pulled to the front, and bottom hooks is removed indoor unit.
- The front panel is pulled to the front, raising the upper surface, and a front panel is removed.

- Remove four screws.
- The thumb is hung on the lower part as shown in the figure, and it pulls to the front, pushing I-mark, and bottom hooks (two position) is removed from wall hook bracket.
- The front panel bottom is pulled to the front, and bottom hooks is removed indoor unit.
- The front panel is pulled to the front, raising the upper surface, and a front panel is removed.

- Remove four screws.
- The thumb is hung on the lower part as shown in the figure, and it pulls to the front, pushing I-mark, and bottom hooks (two position) is removed from wall hook bracket.
- The front panel bottom is pulled to the front, and bottom hooks is removed indoor unit.
- The front panel is pulled to the front, raising the upper surface, and a front panel is removed.

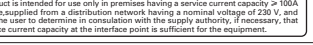
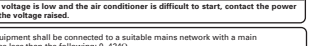
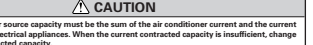
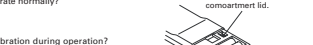
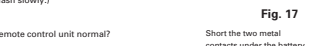
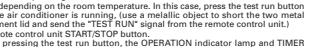

Installation instruction for the indoor unit & outdoor unit is on the back.



# INDOOR UNIT

## CUTTING THE HOLE IN THE WALL FOR THE CONNECTING PIPING

- Cut a 65 mm diameter hole in the wall at the position shown in (Fig. 4).
- When cutting the wall hole at the inside of the installation frame, cut the hole within the range of the left and right center marks 40 mm below the installation frame. When cutting the wall hole at the outside of the installation frame, cut the hole at least 10 mm below over.
- Cut the hole so that the outside end is lower (5 to 10 mm) than the inside end.
- Always align the center of the wall hole. If misaligned, water leakage will occur.
- Cut the wall pipe to match the wall thickness, stick it into the wall cap, fasten the cap with vinyl tape, and stick the pipe through the hole. (The connection pipe is supplied in the installation set.) (Fig. 4)
- For left piping and right piping, cut the hole a little lower so that drain water will flow freely. (Fig. 4)

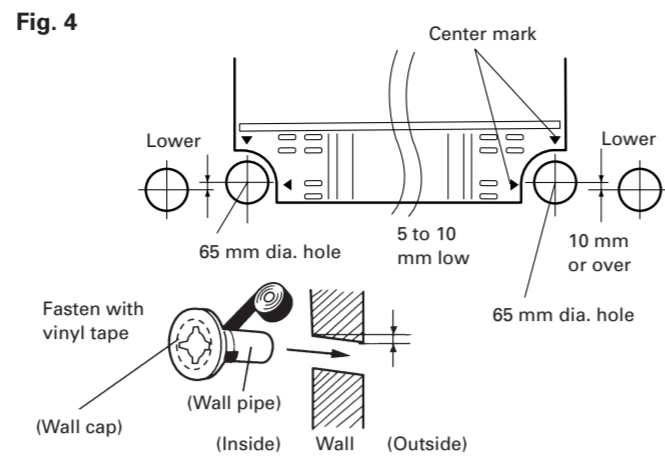

## INSTALLING THE WALL HOOK BRACKET

- Install the wall hook bracket so that it is correctly positioned horizontally and vertically. If the wall hook bracket is tiled, water will drip to the floor.
- Install the wall hook bracket so that it is strong enough to withstand the weight of an adult.
  - Fasten the wall hook bracket to the wall with 6 or more screws through the holes near the outer edge of the bracket.
  - Check that there is no rattle at the wall hook bracket.

**WARNING**  
If the wall pipe is not used, the cord interconnecting the indoor and outdoor units may touch metal and cause electric leakage.

**CAUTION**  
Install the wall hook bracket horizontally and perpendicularly.

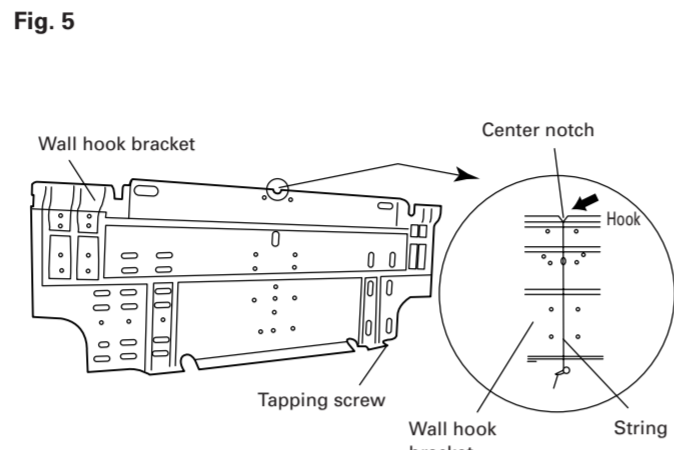

## FORMING THE DRAIN HOSE AND PIPE

### [Rear piping, Right piping, Bottom piping]

- Install the indoor unit piping in the direction of the wall hole and bind the drain hose and pipe together with vinyl tape. (Fig. 6)
- Install the piping so that the drain hose is at the bottom.
- Wrap the pipes of the indoor unit that are visible from the outside with decorative tape.

### [For Left rear piping, Left piping]

Interchange the drain cap and the drain hose.

**CAUTION**  
After removing the drain hose, do not forget to install the drain cap.

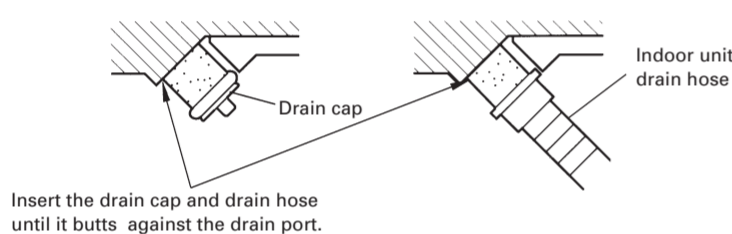

Insert the drain cap and drain hose until it butts against the drain port.

Remove the drain cap by pulling at the projection at the end of the cap with pliers, etc.

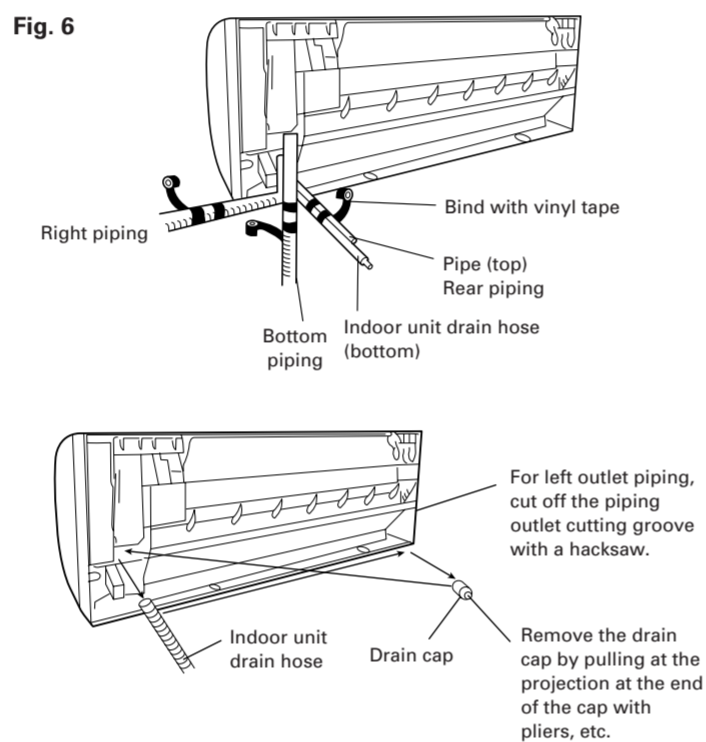

# OUTDOOR UNIT

## OUTDOOR UNIT INSTALLATION

- Set the unit on a strong stand, such as one made of concrete blocks to minimize shock and vibration.
- Do not set the unit directly on the ground because it will cause trouble.

### Connector cover removal

- Remove the two mounting screws.

### Installing the connector cover

- After inserting the three front hooks, then insert the rear hook.
- Tighten the two mounting screws.

## AIR PURGE

Always use a vacuum pump to purge the air. Refrigerant for purging the air is not charged in the outdoor unit at the factory.

Close the high pressure side valve of the gauge manifold fully and do not operate it during the following work.

- Check if the piping connections are secure.
- Check that the stems of 2-way valve and 3-way valve are closed fully.
- Connect the gauge manifold charge hose to the charging port of the 3-way valve (side with the projection for pushing in the valve core).
- Open the low pressure side valve of the gauge manifold fully.
- Operate the vacuum pump and start pump down.
- Slowly loosen the flare nut of the 3-way valve and check if air enters, then retighten the flare nut. (When the flare nut is loosened the operating sound of the vacuum pump changes and the reading of the compound pressure gauge goes from minus to zero.)
- Pump down the system for at least 15 minutes, then check if the compound pressure gauge reads -0.1 MPa (-76 cmHg, -1 bar).
- At the end of pump down, close the low pressure side gauge of the gauge manifold fully and stop the vacuum pump.
- Slowly loosen the valve stem of the 3-way valve. When the compound pressure gauge reading reaches 0.1-0.2 MPa, retighten the valve stem and disconnect the charge hose from the 3-way valve charging port. (If the stem of the 3-way valve is opened fully before the charge hose is disconnected, it may be difficult to disconnect the charge hose.)

- WARNING**
- Install the unit where it will not be tilted by more than 5°.
  - When installing the outdoor unit where it may be exposed to strong wind, fasten it securely.

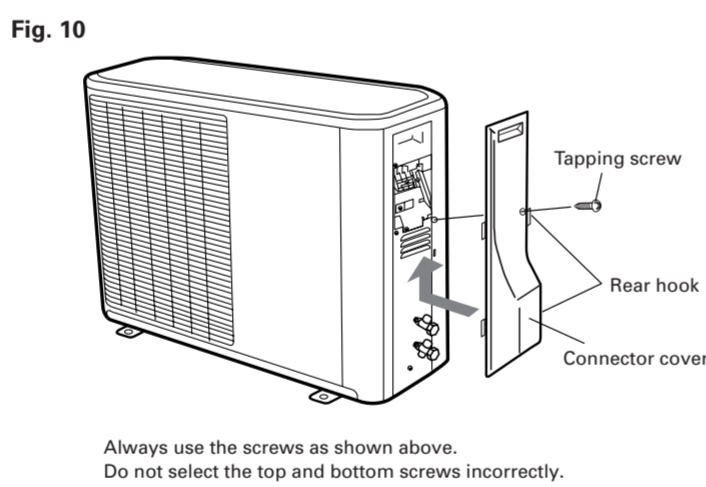

Always use the screws as shown above. Do not select the top and bottom screws incorrectly.

- CAUTION**
- Refrigerant must not be discharged into atmosphere.
  - After connecting the piping, check the joints for gas leakage with gas leak detector.

- Fully open the valve stems of the 2-way valve and 3-way valve using a hexagon wrench. (After the valve stem begins to turn, turn it with a torque of less than 2.9 N·m (30 kgf·cm) until it stops turning.)
- Firmly tighten the 2-way valve and 3-way valve blank cap and the charging port cap.

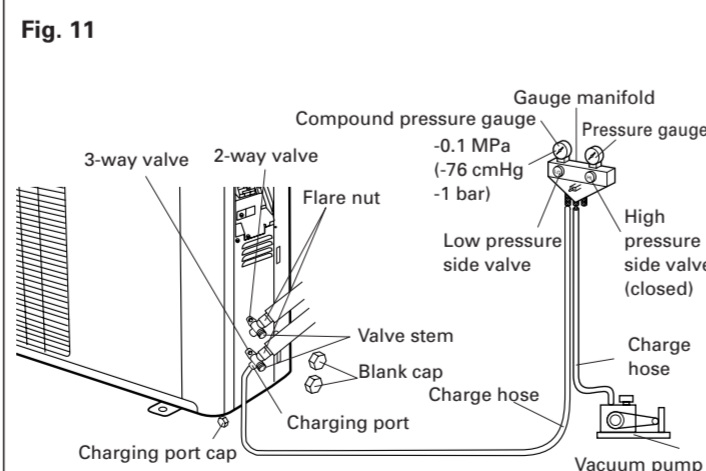

	Tightening torque
Blank cap (2-way valve)	19.6 to 24.5 N·m (200 to 250 kgf·cm)
Blank cap (3-way valve)	27.4 to 31.4 N·m (280 to 320 kgf·cm)
Charging port cap	12.3 to 15.7 N·m (125 to 160 kgf·cm)

- For left piping and left rear piping, align the marks on the wall hook bracket and shape the connection pipe.
- Bend the connection piping at the bend radius of 70 mm or more and install no more than 35 mm from the wall.
- After passing the indoor piping and drain hose through the wall hole, hang the indoor unit on the hooks at the top and bottom of the wall hook bracket.

### [Installing the indoor unit]

- Hang the indoor unit from the hooks at the top of the wall hook bracket.
- Insert the spacer, etc. between the indoor unit and the wall hook bracket and separate the bottom of the indoor unit from the wall.

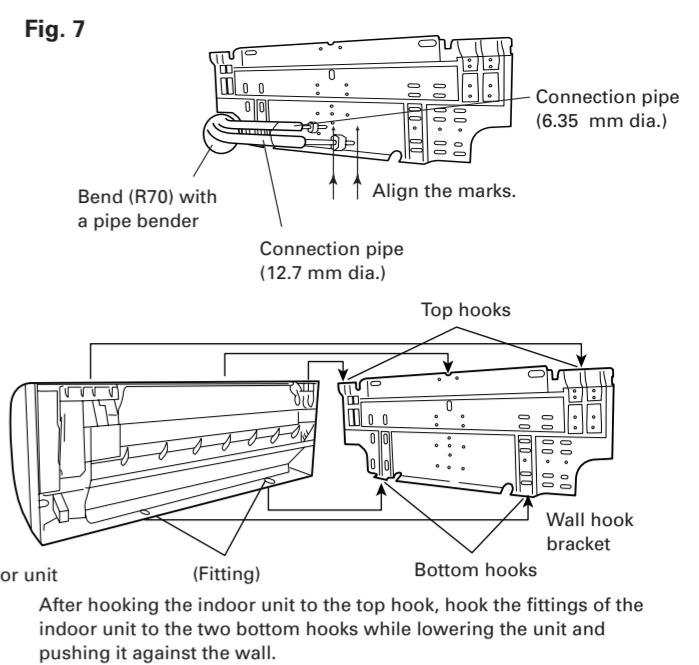
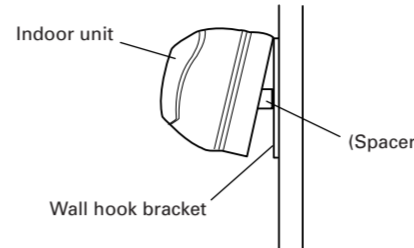

After hooking the indoor unit to the top hook, hook the fittings of the indoor unit to the two bottom hooks while lowering the unit and pushing it against the wall.

## CONNECTING THE PIPING

### CONNECTION

- Install the outdoor unit wall cap (supplied with the optional installation set or procured at the site) to the wall pipe.
- Connect the outdoor unit and indoor unit piping.
- After matching the center of the flare surface and tightening the nut hand tight, tighten the nut to the specified tightening torque with a torque wrench. (Table 2)

### FLARING

- Cut the connection pipe to the necessary length with a pipe cutter.
- Hold the pipe downward so that cuttings will not enter the pipe and remove the burrs.
- Insert the flare nut onto the pipe and flare the pipe with a flaring tool.

Insert the flare nut (always use the flare nut attached to the indoor and outdoor units respectively) onto the pipe and perform the flare processing with a flare tool. Use the special R410A flare tool, or the conventional (for R22) flare tool. When using the conventional flare tool, always use an allowance adjustment gauge and secure the A dimension shown in table 3.

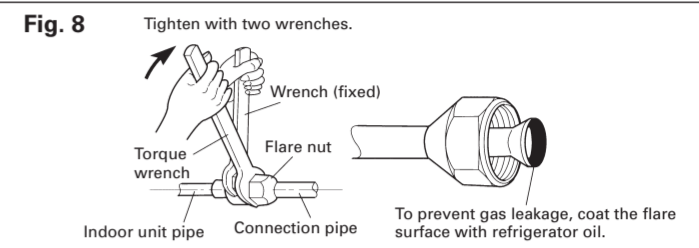
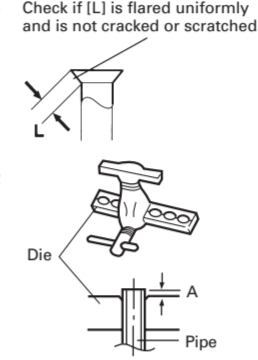

Flare nut	Tightening torque	Tightening torque standard (using a 20 cm wrench)
6.35 mm dia.	15.7 to 17.6 N·m (160 to 180 kgf·cm)	Wrist strength
12.7 mm dia.	49.0 to 53.9 N·m (500 to 550 kgf·cm)	Arm strength

Pipe outside diameter	A (mm)	
	Flash tool for R410A, clutch type	Conventional (R22) flare tool Clutch type Wing nut type
φ 6.35 mm (1/4")	0 to 0.5	1.0 to 1.5 1.5 to 2.0
φ 12.7 mm (1/2")	0 to 0.5	1.0 to 1.5 1.5 to 2.0

## INDOOR UNIT WIRING

- Remove the cord clamp.
- Bend the end of the connection cord as shown in the figure.
- Connect the end of the connection cord fully into the terminal block.
- Fasten the connection cord with a cord clamp.

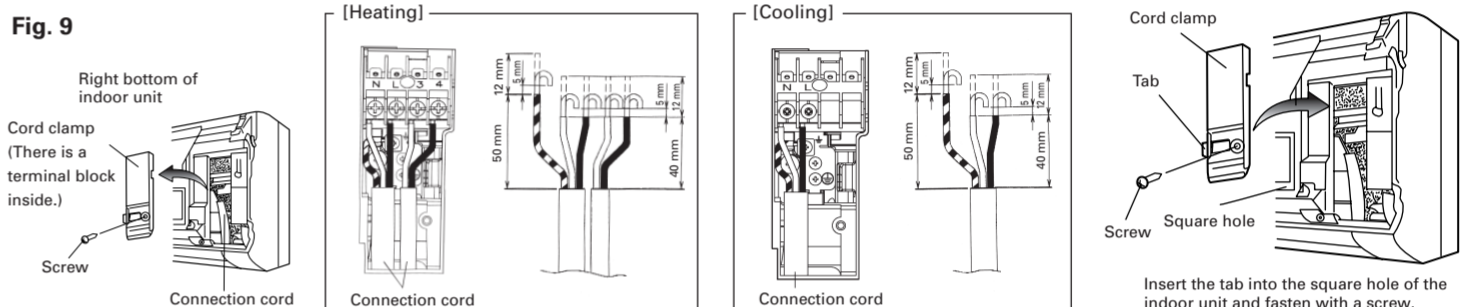

- CAUTION**
- Match the terminal block numbers and connection cord colors with those of the outdoor unit. Erroneous wiring may cause burning of the electric parts.
  - Connect the connection cords firmly to the terminal block. Imperfect installation may cause a fire.
  - Always fasten the outside covering of the connection cord with the cord clamp. (If the insulator is chafed, electric leakage may occur.)
  - Securely earth the power cord plug.
  - Do not use the earth screw for an external connector. Only use for interconnection between two units.

## ADDITIONAL CHARGE

Refrigerant suitable for a piping length of 7.5 m is charged in the outdoor unit at the factory. When the piping is longer than 7.5 m, additional charging is necessary. For the additional amount, see the table below.

Pipe length	7.5 m	10 m	15 m
Additional refrigerant	None	50 g	150 g

Between 7.5 m and 15 m, when using a connection pipe other than that in the table, charge additional refrigerant with 20g/1 m as the criteria.

- CAUTION**
- When adding refrigerant, add the refrigerant from the charging port at the completion of work.
  - The maximum length of the piping is 15 m. If the units are further apart than this, correct operation can not be guaranteed.

## OUTDOOR UNIT WIRING

- Remove the outdoor unit connector cover.
- Remove the control box cover-B.
- Bend the end of the cord as shown in the figure.
- Connect the end of the connection cord fully into the terminal block.
- Fasten the sheath with a cord clamp.
- Install the control box cover-B.
- Install the connector cover.

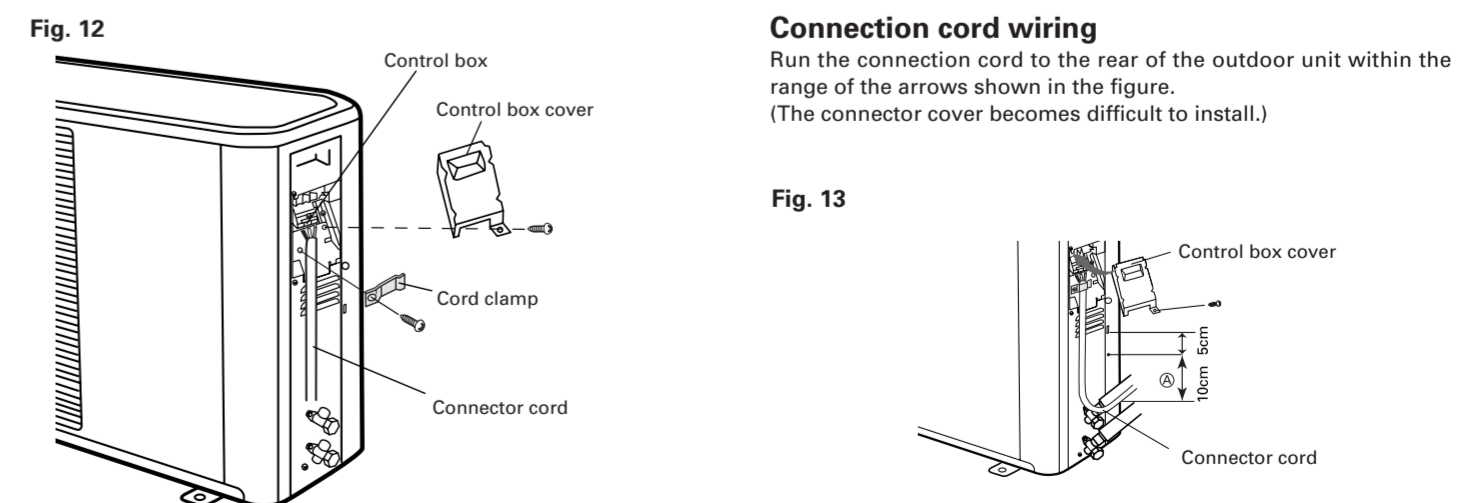
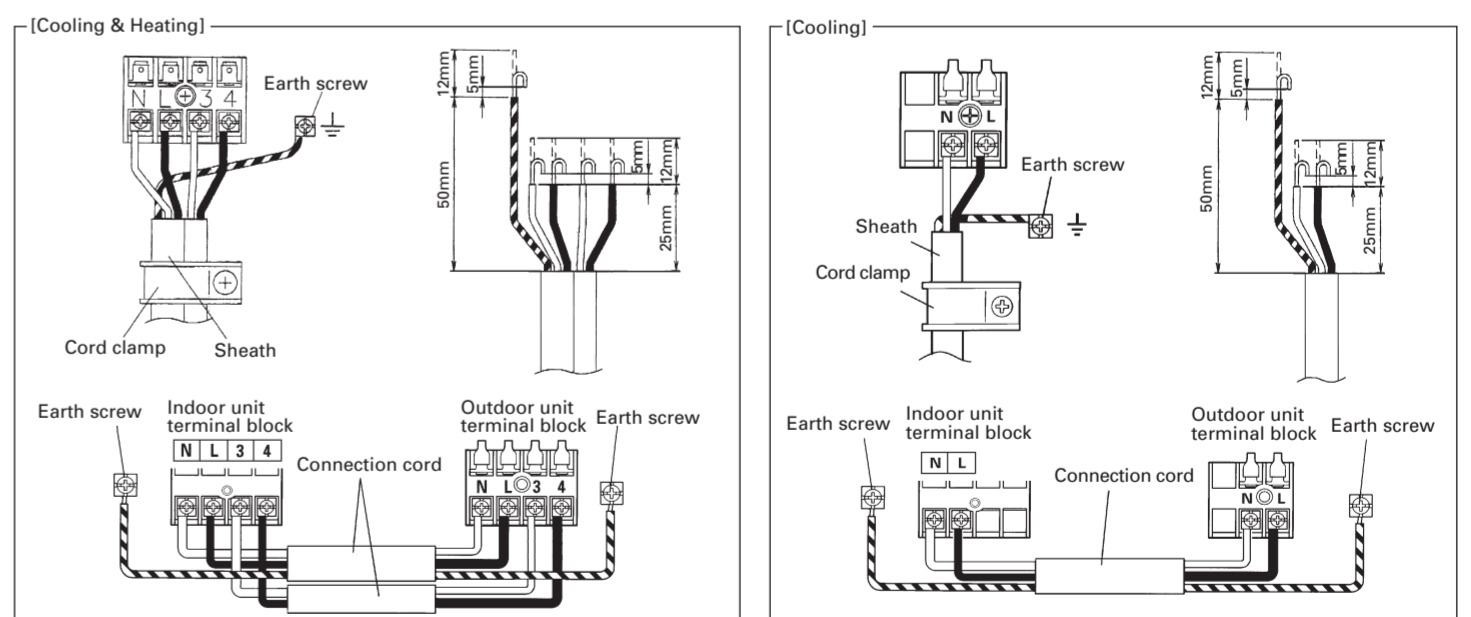

- CAUTION**
- Match the terminal block numbers and connection cord colors with those of the indoor unit. Erroneous wiring may cause burning of the electric parts.
  - Connect the connection cords firmly to the terminal block. Imperfect installation may cause a fire.
  - Always fasten the outside covering of the connection cord with the cord clamp. (If the insulator is chafed, electric leakage may occur.)
  - Securely earth the power cord plug.
  - Do not use the earth screw for an external connector. Only use for interconnection between two units.