

INSTALLATION MANUAL

(PART NO. 9312853014-01)

For authorized service personnel only.

This air conditioner uses new refrigerant HFC (R410A).

The basic installation work procedures are the same as conventional refrigerant (R22) models. However, pay careful attention to the following points:

- (1) Since the working pressure is 1.6 times higher than that of conventional refrigerant(R22) models, some of the piping and installation and service tools are special.(See the table below.) Especially, when replacing a conventional refrigerant(R22) model with a new refrigerant R410A model, always replace the conventional piping and flare nuts with the R410A piping and flare nuts.
- (2) Models that use refrigerant R410A have a different charging port thread diameter to prevent erroneous charging with conventional refrigerant(R22) and for safety. Therefore, check beforehand.[The charging port thread diameter for R410A is 1/2 threads per inch.]
- (3) Be more careful that foreign matter (oil, water, etc.) does not enter the piping than with refrigerant(R22) models. Also, when storing the piping ,securely seal the opening by pinching, taping, etc.
- (4) When charging the refrigerant, take into account the slight change in the composition of the gas and liquid phases, and always charge from the liquid phase side whose composition is stable.

Special tools for R410A

Tool name	Contents of change
Gauge manifold	Pressure is high and cannot be measured with a conventional gauge. To prevent erroneous mixing of other refrigerants, the diameter of each port has been changed. It is recommended the gauge with seals-0.1 to 5.3 MPa (-1 to 53 bar) for high pressure. -0.1 to 3.8 MPa (-1 to 38 bar) for low pressure.
Charge hose	To increase pressure resistance, the hose material and base size were changed.
Vacuum pump	A conventional vacuum pump can be used by installing a vacuum pump adapter.
Gas leakage detector	Special gas leakage detector for HFC refrigerant R410A.

Copper pipes

It is necessary to use seamless copper pipes and it is desirable that the amount of residual oil is less than 40 mg/10m. Do not use copper pipes having a collapsed, deformed or discolored portion (especially on the interior surface). Otherwise, the expansion valve or capillary tube may become blocked with contaminants.

As an air conditioner using R410A incurs pressure higher than when using R22, it is necessary to choose adequate materials.

Thicknesses of copper pipes used with R410A are as shown in Table1.Never us copper pipes thinner than 0.8mm even when it is available on the market.

Table 1 Thicknesses of Annealed Copper Pipes

		Thickness (mm)	
Nominal diameter	Outer diameter (mm)	R410A	(ref.) R22
1/4	6.35	0.80	0.80
3/8	9.52	0.80	0.80

WARNING

- (1) Do not use the existing (for R22) piping and flare nuts.
 - If the existing materials are used, the pressure inside the refrigerant cycle will rise and cause breakage, injury, etc.(Use the special R410A materials.)
- (2) When installing and relocating the air conditioner, do not mix gases other than the specified refrigerant(R410A) to enter the refrigerant cycle.
 - If air or other gas enters the refrigerant cycle, the pressure inside the cycle will rise to an abnormally high value and cause breakage, injury, etc.

SELECTING THE MOUNTING POSITION

Decide the mounting position with the customer as follows:

1. INDOOR UNIT

- (1) Install the indoor unit level on a strong wall which is not subject to vibration.
- (2) The inlet and outlet ports should not be obstructed : the air should be able to blow all over the room.
- (3) Install the unit near an electric outlet or special branch circuit.
- (4) Do not install the unit where it will be exposed to direct sunlight.
- (5) Install the unit where connection to the outdoor unit is easy.
- (6) Install the unit where the drain pipe can be easily installed.
- (7) Take servicing, etc. into consideration and leave the spaces shown in (Fig. 2). Also install the unit where the filter can be removed.

2. OUTDOOR UNIT

- (1) If possible, do not install the unit where it will be exposed to direct sunlight. (If necessary, install a blind that does not interfere with the air flow.)
- (2) Do not install the unit where a strong wind blows or where it is very dusty.
- (3) Do not install the unit where people pass.
- (4) Take you neighbors into consideration so that they are not disturbed by air blowing into their windows or by noise.
- (5) Provide the space shown in Fig. 2 so that the air flow is not blocked. Also for efficient operation, leave open three of the four directions front, rear, and both sides.

INSTALLATION DIAGRAM OF INDOOR AND OUTDOOR UNITS

Fig. 2

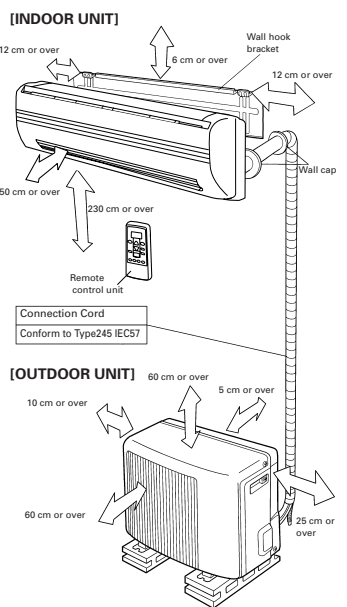

WARNING

Install at a place that can withstand the weight of the indoor and outdoor units and install positively so that the units will not topple or fall.

CAUTION

- (1) Do not install where there is the danger of combustible gas leakage.
- (2) Do not install near heat sources.
- (3) If children under 10 years old may approach the unit, take preventive measures so that they cannot reach the unit.
- (4) Install the indoor unit on the wall where the height from the floors more than 230 cm.

[Indoor unit piping direction]

The piping can be connected in the five directions indicated by ①, ②, ③, ④, and ⑤ in (Fig. 1). When the piping is connected in direction ② or ③, cut along the piping groove in the side of the under cover with a hacksaw.

When connecting the piping in direction ③, cut a notch in the thin wall at the front bottom of the under cover.

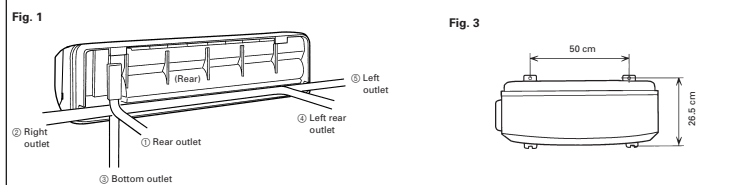

WARNING

- (1) For the room air conditioner to operate satisfactory, install it as outlined in this installation manual.
- (2) Connect the indoor unit and outdoor unit with the air conditioner piping and cords available standards parts. This installation manual describes the correct connections using the standard accessories and the parts specified in this installation manual.
- (3) Have installation work done by authorized service personnel only.
- (4) Never cut the power cord, lengthen or shorten the cord, or change the plug.
- (5) Also do not use an extension cord.
- (6) Plug in the power cord plug firmly. If the receptacle is loose, repair it before using the room air conditioner.
- (7) Do not turn on the power until all installation work is complete.

- Be careful not to scratch the air conditioner when handling it.
- After installation, explain correct operation to the customer, using the operating manual.
- Let the customer keep this installation manual because it is used when the air conditioner is serviced or moved.
- The maximum length of the piping is 15 m. The maximum height difference of the piping is 8 m, if the units are further apart than these, correct operation can not be guaranteed.

STANDARD ACCESSORIES

The following installation accessories are supplied. Use them as required.

One set of following parts are necessary in installation of this product.

Name and Shape	Q'ty	Name and Shape	Q'ty
Wall hook bracket	1	Drain pipe (including drain packing) (Reverse cycle type only)	1
Remote control unit	1	Cloth tape	1
Battery	2	Tapping screw	8

Name
Connection pipe assembly
Connection cord (3-conductor)
Wall pipe
Decorative tape
Vinyl tape
Wall cap
Saddle
Drain hose
Tapping screws
Sealant

ELECTRICAL REQUIREMENT

Always make the air conditioner power supply a special branch circuit and provide a special switch and receptacle. Do not extend the power cord.

FRONT PANEL REMOVAL AND INSTALLATION

The intake grille removal

- (1) Open the intake grille.
- (2) Pull down the knob.
- (3) Open the intake grille , and lift the intake grille upward ,until the axle at the top of the intake grille is removed.

The intake grille installation

- (1) The fixing axle of the intake grille is installed on the front panel.
- (2) Push the knob up to the position.
- (3) Lay down the intake grille.

The front panel removal

- (1) Turn the wind guide and remove two screws at two sides of air outlet.
- (2) Take out the air outlet part of the front panel, then lift the whole front panel up to remove it.

The front panel installation

- (1) Firstly fit the lower part of the front panel to the air outlet part and insert its lower edge into the slot of the under cover.
- (2) Insert three hooks on the upper side of the front panel into the slot of bracket.
- (3) Turn the wind guide, tighten the screws, and then turn the wind guide back to its original position.

THE UNDER COVER REMOVAL AND INSTALLATION

The under cover removal should be done after the panel has been removed beforehand, or the parts may be damaged. The under cover should be installed before the fixing of the panel, or it may result in poor installation.

The under cover removal

- (1) While pressing the joint part between the right part of the under cover and the bracket, pull it out of the slot.
- (2) Hold two sides of the under cover and slide it to the left. Make sure its lower part getting out of the slot.
- (3) Turn the right part of the under cover lower-left to separate the left slot of the under cover from the bracket.

The under cover installation

- (1) Hold two sides of the under cover and align it to the side of the bracket. Firstly match the left slot on the under cover to the slot of the bracket.
- (2) Make five slots on the under cover fit into the fixing plate of the body, then slide it to the right until the left side of the under cover align to the bracket.
- (3) Push the right part of the under cover inward to make the slot and bracket engaged with each other completely.

CAUTION

Install the front panel and intake grille securely. If installation is imperfect, the front panel or intake grille may fall off and cause injury.

Be sure that the top hole of the front panel is hooked securely to the hook of the base.

CUSTOMER GUIDANCE

Explain the following to the customer in accordance with the operating manual:

- (1) Starting and stopping method, operation switching, temperature adjustment, timer, air flow switching, and other remote control unit operations.
- (2) Air filter removal and cleaning, and how to use the air louvers.
- (3) Give the operating and installation manuals to the customer.

TEST RUNNING

- Perform test operation and check items 1 and 2 below.
- For the test operation method, refer to the operating manual.
- The outdoor unit, may not operate, depending on the room temperature. In this case, press the test run button on the remote control unit while the air conditioner is running. (Point the transmitter section of the remote control unit toward the air conditioner and press the test run button with the tip of a ball-point pen, etc.)
- To end test operation, press the remote control unit START/STOP button. (When the air conditioner is run by pressing the test run button, the OPERATION indicator lamp and TIMER indicator lamp will simultaneously flash slowly.)

1. INDOOR UNIT

- (1) Is operation of each button on the remote control unit normal?
- (2) Does each lamp light normally?
- (3) Do the air flow-direction louvers operate normally?
- (4) Is the drain normal?

2. OUTDOOR UNIT

- (1) Is there any abnormal noise and vibration during operation?
- (2) Will noise, wind, or drain water from the unit disturb the neighbors?
- (3) Is there any gas leakage?

POWER

WARNING

- (1) The rated voltage of this product is 230 V AC 50 Hz.
- (2) Before turning on the power, check if the voltage is within the 220 V -10 % to 240 V +10 % range.
- (3) Always use a special branch circuit and install a special receptacle to supply power to the room air conditioner.
- (4) Use a circuit breaker and receptacle matched to the capacity of the air conditioner.
- (5) Do not extend the power cord.
- (6) Perform wiring work in accordance with standards so that the air conditioner can be operated safely and positively.
- (7) Install a leakage circuit breaker in accordance with the related laws and regulations and electric company standards.

CAUTION

- (1) The power source capacity must be the sum of the air conditioner current and the current of other electrical appliances. When the current contracted capacity is insufficient, change the contracted capacity.
- (2) When the voltage is low and the air conditioner is difficult to start, contact the power company voltage raised.

NOTE: These equipment shall be connected to a suitable mains network with a main impedance less than the following: 0.424Ω. The product is intended for use only in premises having a service current capacity >= 100A per phase, supplied from a distribution network having a nominal voltage of 230 V, and instruct the user to determine in consultation with the supply authority, if necessary, that the service current capacity at the interface points is sufficient for the equipment.

INDOOR UNIT

CUTTING THE HOLE IN THE WALL FOR THE CONNECTING PIPING

- Cut a 65 mm diameter hole in the wall at the position shown in (Fig. 7).
- When cutting the wall hole at the inside of the installation frame, cut the hole within the range of the left and right center marks 40 mm below the installation frame. When cutting the wall hole at the outside of the installation frame, cut the hole at least 10 mm below over.
- Cut the hole so that the outside end is lower (5 to 10 mm) than the inside end.
- Always align the center of the wall hole. If misaligned, water leakage will occur.
- Cut the wall pipe to match the wall thickness, stick it into the wall cap, fasten the cap with vinyl tape, and stick the pipe through the hole. (The connection pipe is supplied in the installation set.) (Fig. 7)
- For left piping and right piping, cut the hole a little lower so that drain water will flow freely. (Fig. 7)

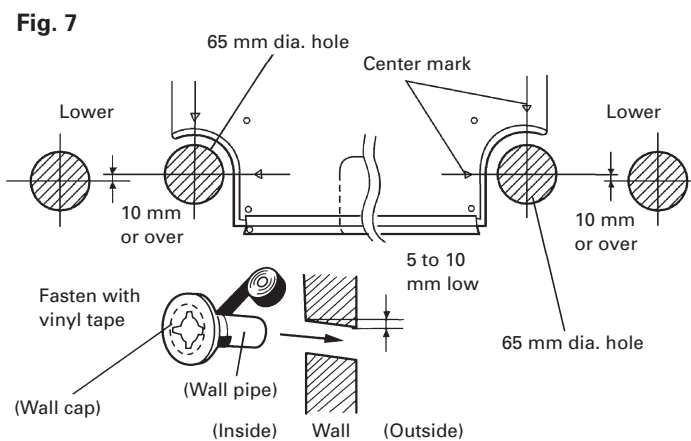

INSTALLING THE WALL HOOK BRACKET

- Install the wall hook bracket so that it is correctly positioned horizontally and vertically. If the wall hook bracket is tiled, water will drip to the floor.
- Install the wall hook bracket so that it is strong enough to withstand the weight of an adult. Before fastening the wall hook bracket to the wall with the screws, level it by tapping the hook at the center of bracket to the wall with the handle of a screwdriver.
- Fasten the wall hook bracket to the wall with 6 or more screws through the holes near the outer edge of the bracket.
- Check that there is no rattle at the wall hook bracket.

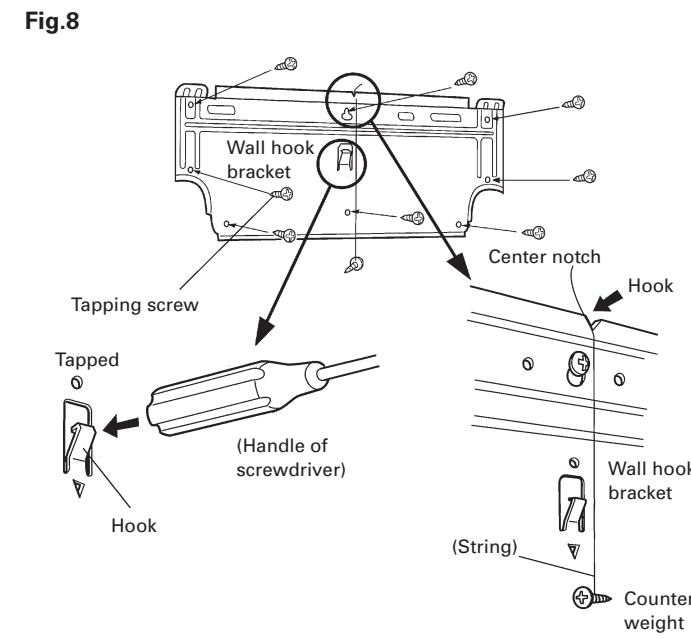

WARNING

If the wall pipe is not used, the cord interconnecting the indoor and outdoor units may touch metal and cause electric leakage.

CAUTION

Install the wall hook bracket horizontally and perpendicularly.

FORMING THE DRAIN HOSE AND PIPE

[Rear piping, Right piping, Bottom piping]

- Install the indoor unit piping in the direction of the wall hole and bind the drain hose and pipe together with vinyl tape. (Fig. 9)
- Install the piping so that the drain hose is at the bottom.
- Wrap the pipes of the indoor unit that are visible from the outside with decorative tape.

[For Left rear piping, Left piping]

Interchange the drain cap and the drain hose.

CAUTION

After removing the drain hose, do not forget to install the drain cap.

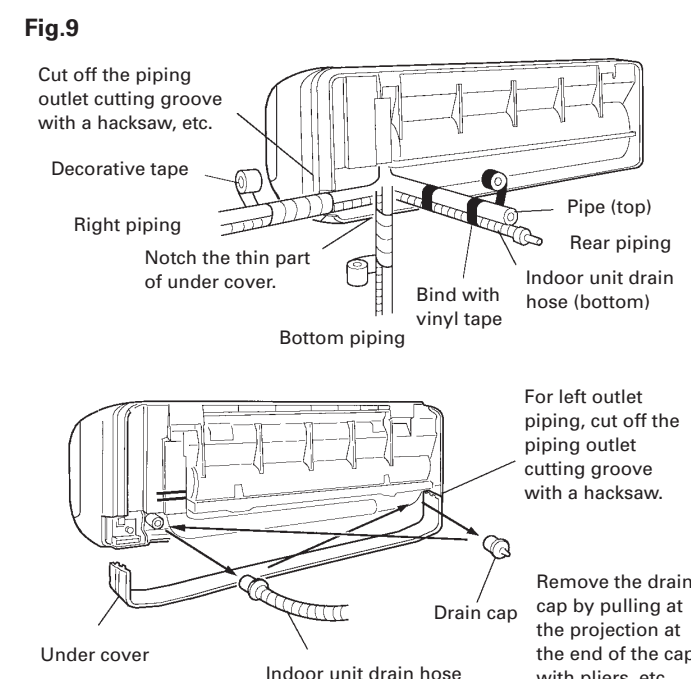
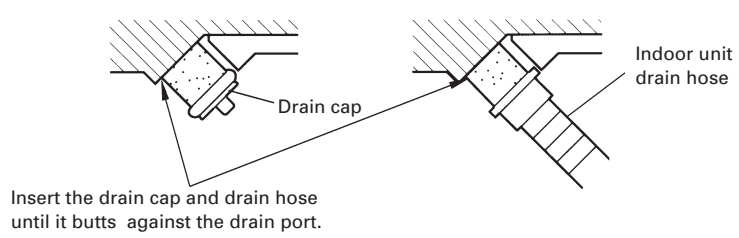

OUTDOOR UNIT

OUTDOOR UNIT INSTALLATION

- Set the unit on a strong stand, such as one made of concrete blocks to minimize shock and vibration.
- Do not set the unit directly on the ground because it will cause trouble.

Connector cover removal

- Remove the two mounting screws.
- Put your hand on the back side (mark) and take out the connector cover forwards.

Installing the connector cover

- After inserting the three front hooks, then insert the rear hook.
- Tighten the two mounting screws.

- WARNING**
- Install the unit where it will not be tilted by more than 5°.
 - When installing the outdoor unit where it may be exposed to strong wind, fasten it securely.

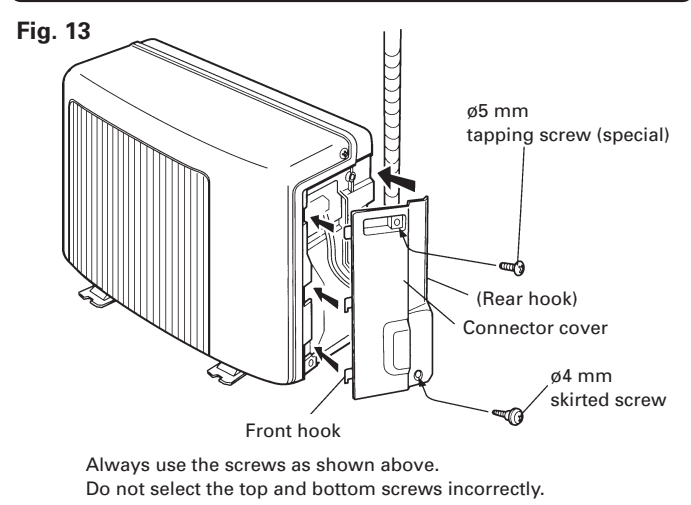

AIR PURGE

Always use a vacuum pump to purge the air. Refrigerant for purging the air is not charged in the outdoor unit at the factory.

Close the high pressure side valve of the gauge manifold fully and do not operate it during the following work.

- Check if the piping connections are secure.
- Check that the stems of 2-way valve and 3-way valve are closed fully.
- Connect the gauge manifold charge hose to the charging port of the 3-way valve (side with the projection for pushing in the valve core).
- Open the low pressure side valve of the gauge manifold fully.
- Operate the vacuum pump and start pump down.
- Slowly loosen the flare nut of the 3-way valve and check if air enters, then retighten the flare nut. (When the flare nut is loosened the operating sound of the vacuum pump changes and the reading of the compound pressure gauge goes from minus to zero.)
- Pump down the system for at least 15 minutes, then check if the compound pressure gauge reads -0.1 MPa (-76 cmHg, -1 bar).
- At the end of pump down, close the low pressure side gauge of the gauge manifold fully and stop the vacuum pump.
- Slowly loosen the valve stem of the 3-way valve. When the compound pressure gauge reading reaches 0.1-0.2 MPa, retighten the valve stem and disconnect the charge hose from the 3-way valve charging port. (If the stem of the 3-way valve is opened fully before the charge hose is disconnected, it may be difficult to disconnect the charge hose.)

- CAUTION**
- Refrigerant must not be discharged into atmosphere.
 - After connecting the piping, check the joints for gas leakage with gas leak detector.

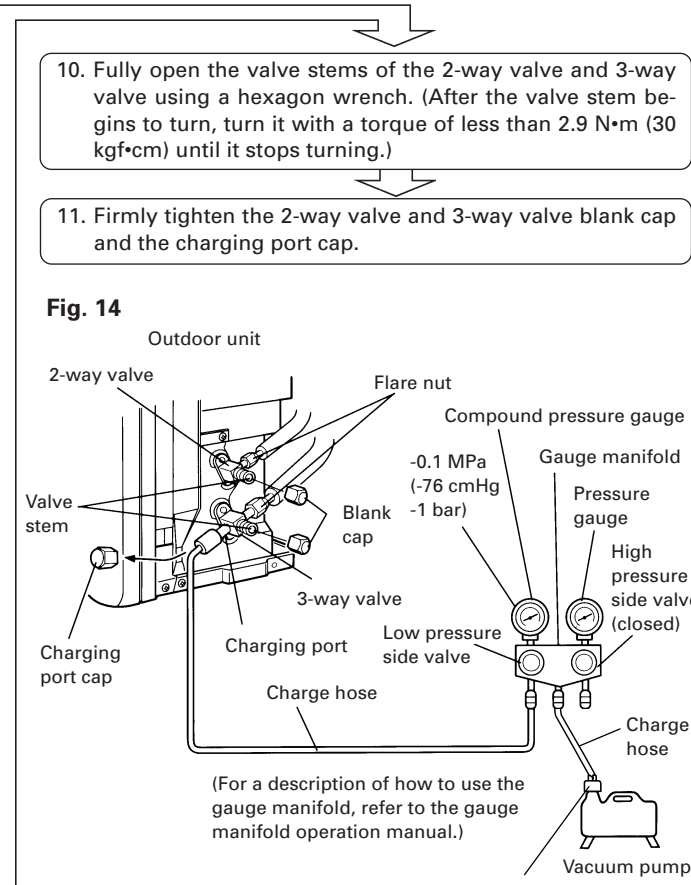

	Tightening torque
Blank cap	19.6 to 24.5 N·m (200 to 250 kgf·cm)
Charging port cap	12.3 to 15.7 N·m (125 to 160 kgf·cm)

- For left piping and left rear piping, align the marks on the wall hook bracket and shape the connection pipe.
- Bend the connection piping at the bend radius of 70 mm or more and install no more than 35 mm from the wall.
- After passing the indoor piping and drain hose through the wall hole, hang the indoor unit on the hooks at the top and bottom of the wall hook bracket.

[Installing the indoor unit]

- Hang the indoor unit from the hooks at the top of the wall hook bracket.
- Insert the spacer, etc. between the indoor unit and the wall hook bracket and separate the bottom of the indoor unit from the wall.

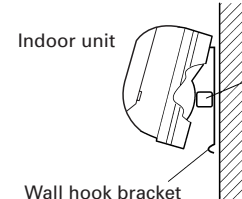
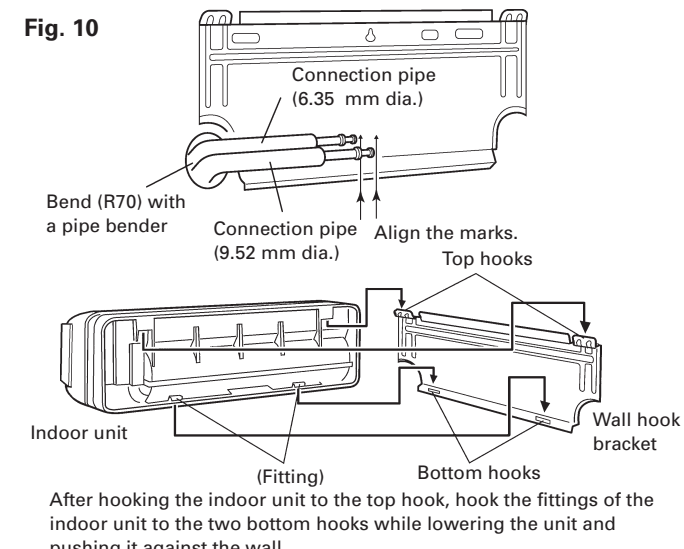

Fig. 10



CONNECTING THE PIPING

Connection

- Install the outdoor unit wall cap (supplied with the optional installation set or procured at the site) to the wall pipe.
- Connect the outdoor unit and indoor unit piping.
- After matching the center of the flare surface and tightening the nut hand tight, tighten the nut to the specified tightening torque with a torque wrench. (Table 2)

Flaring

- Cut the connection pipe to the necessary length with a pipe cutter.
- Hold the pipe downward so that cuttings will not enter the pipe and remove the burrs.
- Insert the flare nut onto the pipe and flare the pipe with a flaring tool.

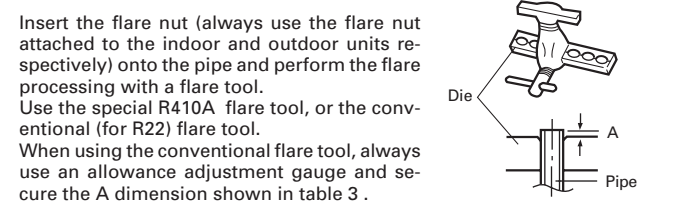

Fig. 11

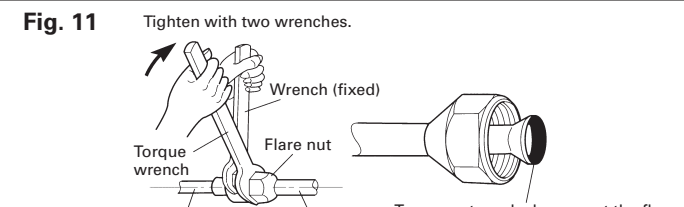

Table 2 Flare nut tightening torque

Flare nut	Tightening torque	Tightening torque standard (using a 20 cm wrench)
6.35 mm dia.	15.7 to 17.6 N·m (160 to 180 kgf·cm)	Wrist strength
9.52 mm dia.	29.4 to 41.1 N·m (300 to 420 kgf·cm)	Arm strength

Table 3 Pipe outside diameter

Pipe outside diameter	A (mm)		
	Flash tool for R410A, clutch type	Conventional (R22) flare tool Clutch type	Wing nut type
ø 6.35 mm (1/4")	0 to 0.5	1.0 to 1.5	1.5 to 2.0
ø 9.52 mm (3/8")	0 to 0.5	1.0 to 1.5	1.5 to 2.0

[Reverse cycle type]

- Remove the cord clamp.
- Bend the end of the connection cord as shown in the figure.
- Connect the end of the connection cord fully into the terminal block.
- Match the terminal block numbers and connection cord with those of the outdoor unit.
- Fasten the connection cord with a cord clamp.

Fig. 12

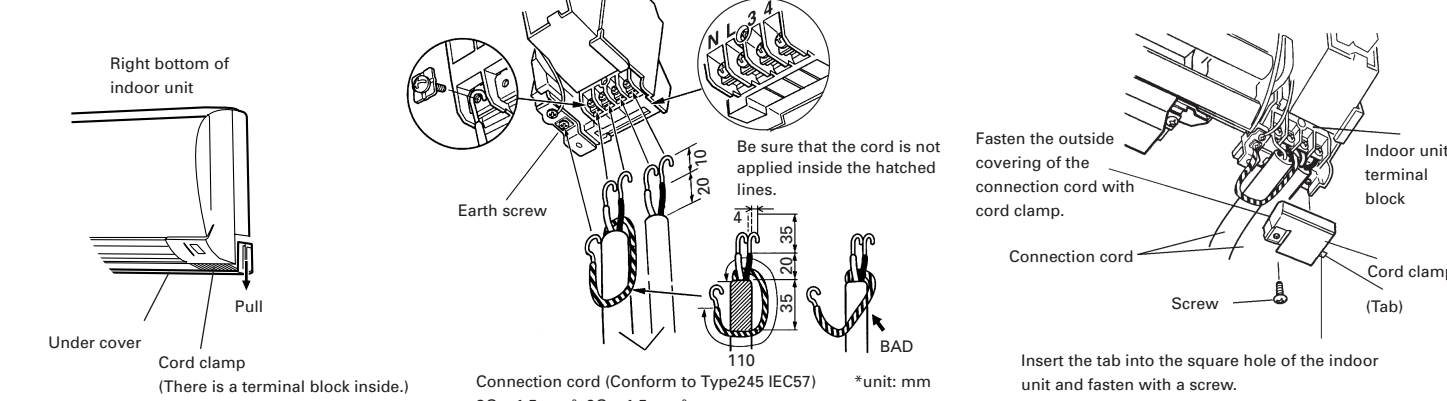

CAUTION

- Match the terminal block numbers and connection cord colors with those of the outdoor unit. Erroneous wiring may cause burning of the electric parts.
- Connect the connection cords firmly to the terminal block. Imperfect installation may cause a fire.
- Always fasten the outside covering of the connection cord with the cord clamp. (If the insulator is chafed, electric leakage may occur.)
- Securely earth the power cord plug.
- Do not use the earth screw for an external connector. Only use for interconnection between two units.

OUTDOOR UNIT

OUTDOOR UNIT INSTALLATION

- Set the unit on a strong stand, such as one made of concrete blocks to minimize shock and vibration.
- Do not set the unit directly on the ground because it will cause trouble.

Connector cover removal

- Remove the two mounting screws.
- Put your hand on the back side (mark) and take out the connector cover forwards.

Installing the connector cover

- After inserting the three front hooks, then insert the rear hook.
- Tighten the two mounting screws.

- WARNING**
- Install the unit where it will not be tilted by more than 5°.
 - When installing the outdoor unit where it may be exposed to strong wind, fasten it securely.

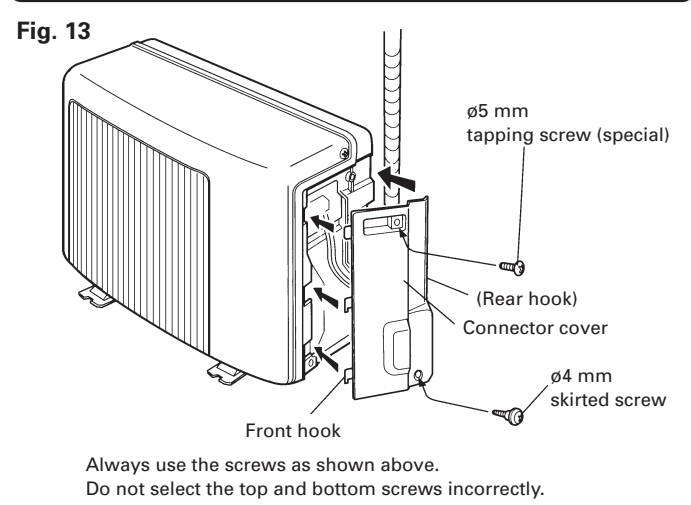

Additional charge

Refrigerant suitable for a piping length of 7.5 m is charged in the outdoor unit at the factory. When the piping is longer than 7.5 m, additional charging is necessary. For the additional amount, see the table below.

Table 5

Pipe length	7.5 m	10 m	15 m
Additional refrigerant	None	50 g	150 g

CAUTION

- When adding refrigerant, add the refrigerant from the charging port at the completion of work.
- The maximum length of the piping is 15 m. If the units are further apart than this, correct operation cannot be guaranteed.

Between 7.5 m and 15 m, when using a connection pipe other than that in the table, charge additional refrigerant with 20g/1 m as the criteria.

OUTDOOR UNIT WIRING

- Remove the outdoor unit connector cover.
- Remove the control box cover-B.
- Bend the end of the cord as shown in the figure.
- Connect the end of the connection cord fully into the terminal block.

[Reverse cycle type]

Fig. 15

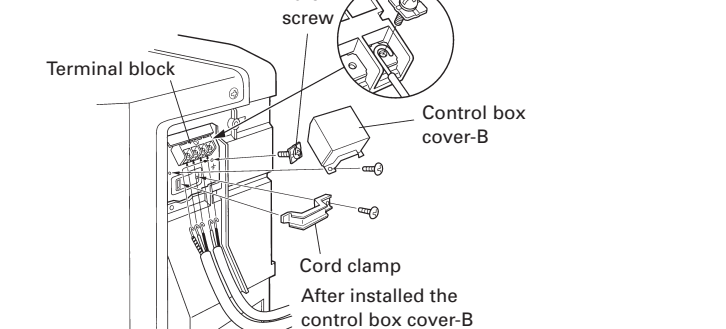

- Fasten the sheath with a cord clamp.
- Install the control box cover-B.
- Install the connector cover.

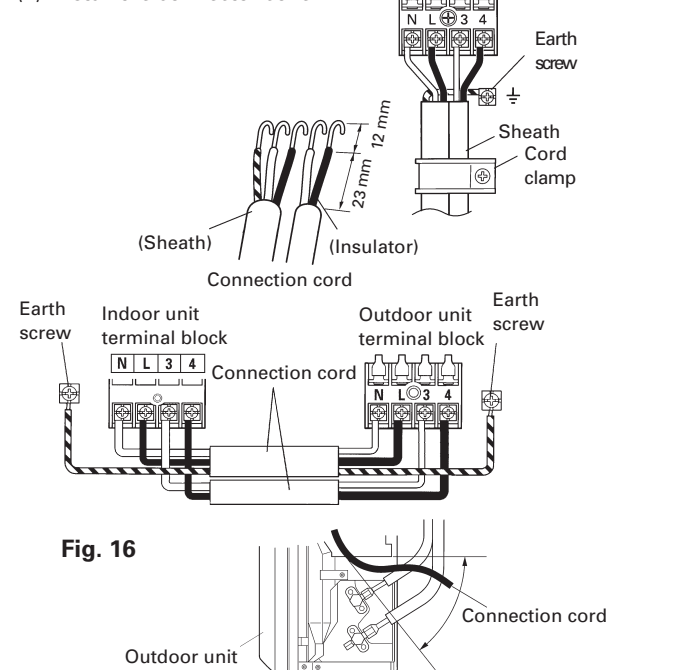

Connection cord wiring

Run the connection cord to the rear of the outdoor unit within the range of the arrows shown in the figure. (The connector cover becomes difficult to install.)

CAUTION

- Match the terminal block numbers and connection cord colors with those of the indoor unit. Erroneous wiring may cause burning of the electric parts.
- Connect the connection cords firmly to the terminal block. Imperfect installation may cause a fire.
- Always fasten the outside covering of the connection cord with the cord clamp. (If the insulator is chafed, electric leakage may occur.)
- Securely earth the power cord plug.
- Do not use the earth screw for an external connector. Only use for interconnection between two units.

FINISHING

- Insulate between pipes.
 - For rear, right, and bottom piping, overlap the connection pipe heat insulation and indoor unit pipe heat insulation and bind them with vinyl tape so that there is no gap.
 - For left and left rear piping, butt the connection pipe heat insulation and indoor unit pipe heat insulation together and bind them with vinyl tape so that there is no gap.
 - For left and left rear piping, wrap the area which accommodates the rear piping housing section with cloth tape.
 - For left and left rear piping, bind the connection cord to the top of the pipe with vinyl tape.
 - For left and left rear piping, bundle the piping and drain hose together by wrapping them with cloth tape over the range within which they fit into the rear piping housing section.
- Temporarily fasten the connection cord along the connection pipe with vinyl tape. (Wrap to about 1/3 the width of the tape from the bottom of the pipe so that water does not enter.)
- Fasten the connection pipe to the outside wall with saddles, etc.
- Fill the gap between the outside wall pipe hole and the pipe with sealer so that rain water and wind cannot blow in.
- Fasten the drain hose to the outside wall, etc.

Fig. 17

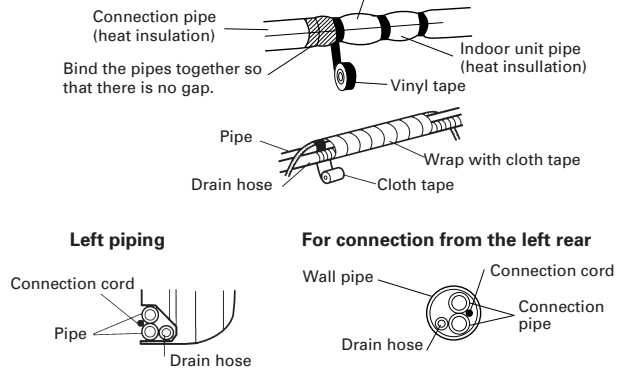

Fig. 18

