

FUJII ELECTRIC

SPLIT TYPE ROOM AIR CONDITIONER

WALL MOUNTED type

SERVICE MANUAL

Models	Indoor unit	Outdoor unit
	RSW-20AB	ROW-20AB
	RSW-24AB	ROW-24AB

C O N T E N T S

SPECIFICATIONS	1
REFRIGERANT SYSTEM DIAGRAM	2
CIRCUIT DIAGRAM	3
P.C. BOARD LAYOUTS	5
REMOTE CONTROL UNIT CIRCUIT DIAGRAM	6
DISASSEMBLY ILLUSTRATION	7
PARTS LIST	13

S P E C I F I C A T I O N S

TYPE		COOL	COOL
INDOOR UNIT		RSW-20AB	RSW-24AB
OUTDOOR UNIT		ROW-20AB	ROW-24AB
COOLING CAPACITY	(kW)	5.80 - 5.90	6.75 - 6.85

ELECTRICAL DATA

POWER SOURCE	(V)	220 - 240	220 - 240
FREQUENCY	(Hz)	50	50
RUNNING CURRENT	(A)	10.3 - 11.0	12.6 - 12.8
INPUT WATTS	(kW)	2.11 - 2.27	2.66 - 2.81
EER	(kW/kW)	2.75 - 2.60	2.54 - 2.44
MOISTURE REMOVAL	(ℓ/hr)	2.0	2.8
AIR CIRCULATION-Hi	(m ³ /hr)	840	1,000

COMPRESSOR

TYPE	Hermetic type, Permanent split condenser, 2 pole, Single phase, Induction motor		
CODE		2JS350D5AB02	2JS438D5AA02
REFRIGERANT	R-22 (g)	1,500	1,870

FAN MOTOR

POWER SOURCE	(V)	220 - 240	220 - 240
INDOOR UNIT	TYPE	MFA-20CTH	MFA-24CTH
	HI-SPEED (r.p.m.)	1,060 - 1,110	1,220 - 1,290
	MED-SPEED (r.p.m.)	890 - 970	1,050 - 1,140
	LO-SPEED (r.p.m.)	740 - 810	890 - 970
OUTDOOR UNIT	TYPE	MFB-247FB	MFB-247FB
	(r.p.m.)	735	735

DIMENSIONS

INDOOR UNIT	H x W x D (mm)	320 x 1,250 x 195	320x 1,250 x 195
OUTDOOR UNIT		643 x 840 x 336	643 x 840 x 336

WEIGHTS

INDOOR UNIT	GROSS / NET (kg)	25 / 18	25 / 18
OUTDOOR UNIT		67 / 59	68 / 60

REFRIGERANT CHARGING

PIPE LENGTH		16 ft. (5 m)	33 ft. (10 m)	49 ft. (15 m)	66 ft. (20 m)
FULL CHARGE AMOUNT	RSW-20AB	1,500 g (52.9 oz.)	1,580 g (55.7 oz.)	1,660 g (58.6 oz.)	1,740 g (61.4 oz.)
	RSW-24AB	1,870 g (66.0 oz.)	1,950 g (68.8 oz.)	2,030 g (71.6 oz.)	2,110 g (74.4 oz.)

Note : It is in the case that 5 m are exceeded, when using a connection pipe other than that in the table, charge additional refrigerant with 16 g (0.56 oz.) / 1 m (3.3 ft.) as the criteria.

REFRIGERANT SYSTEM DIAGRAM

Models : RSW-20AB / ROW-20AB

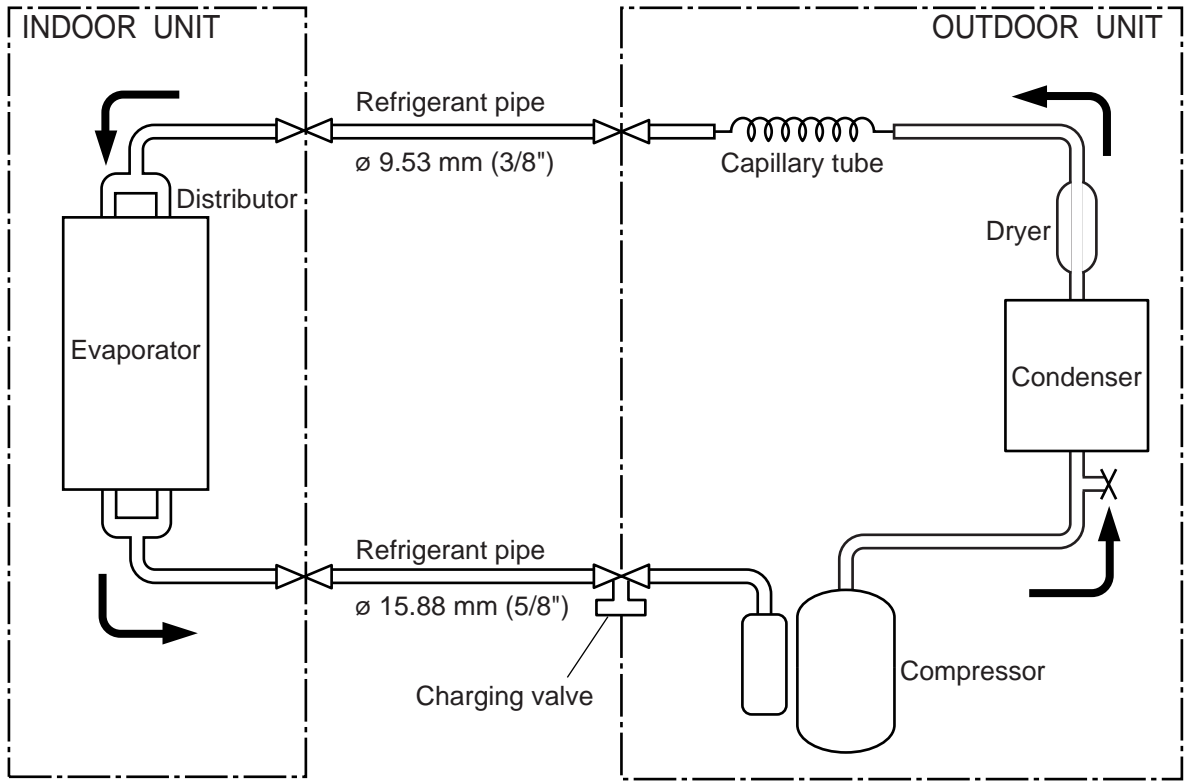

Models : RSW-24AB / ROW-24AB

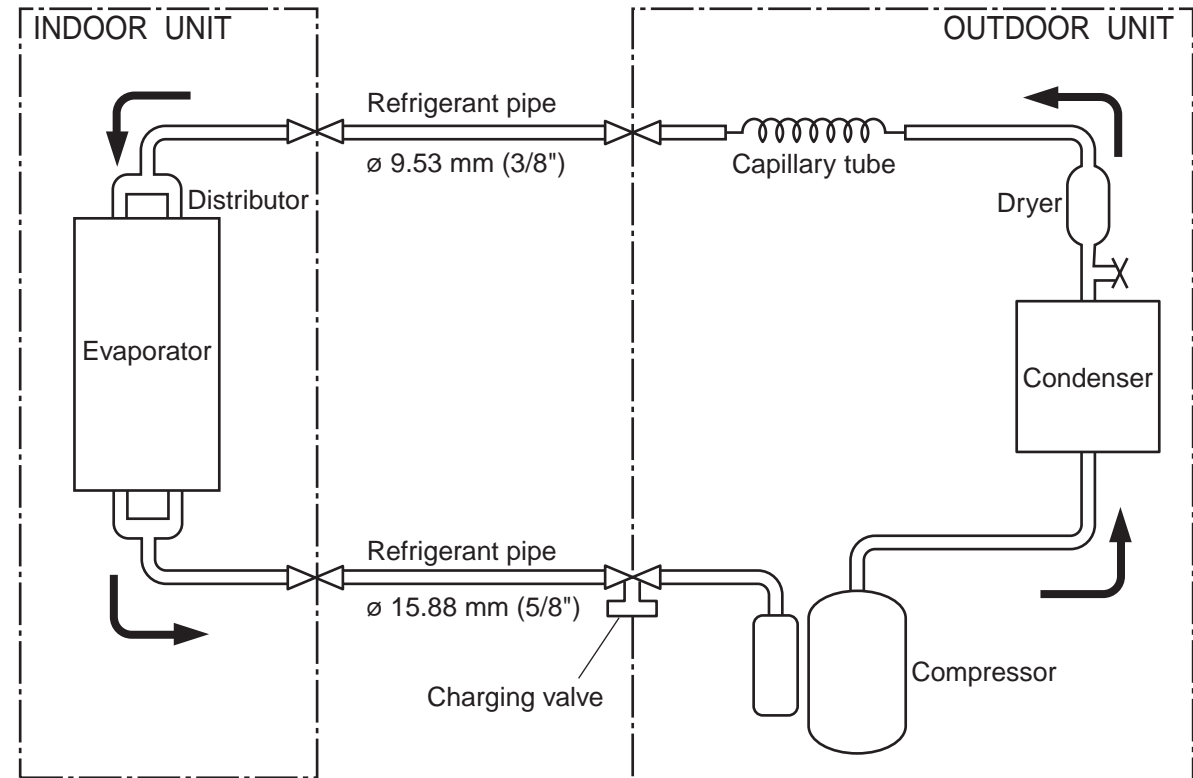

→ Cooling

⊗ : Flare coupling

CIRCUIT DIAGRAM

**Models : RSW-20AB / ROW-20AB
RSW-24AB / ROW-24AB**

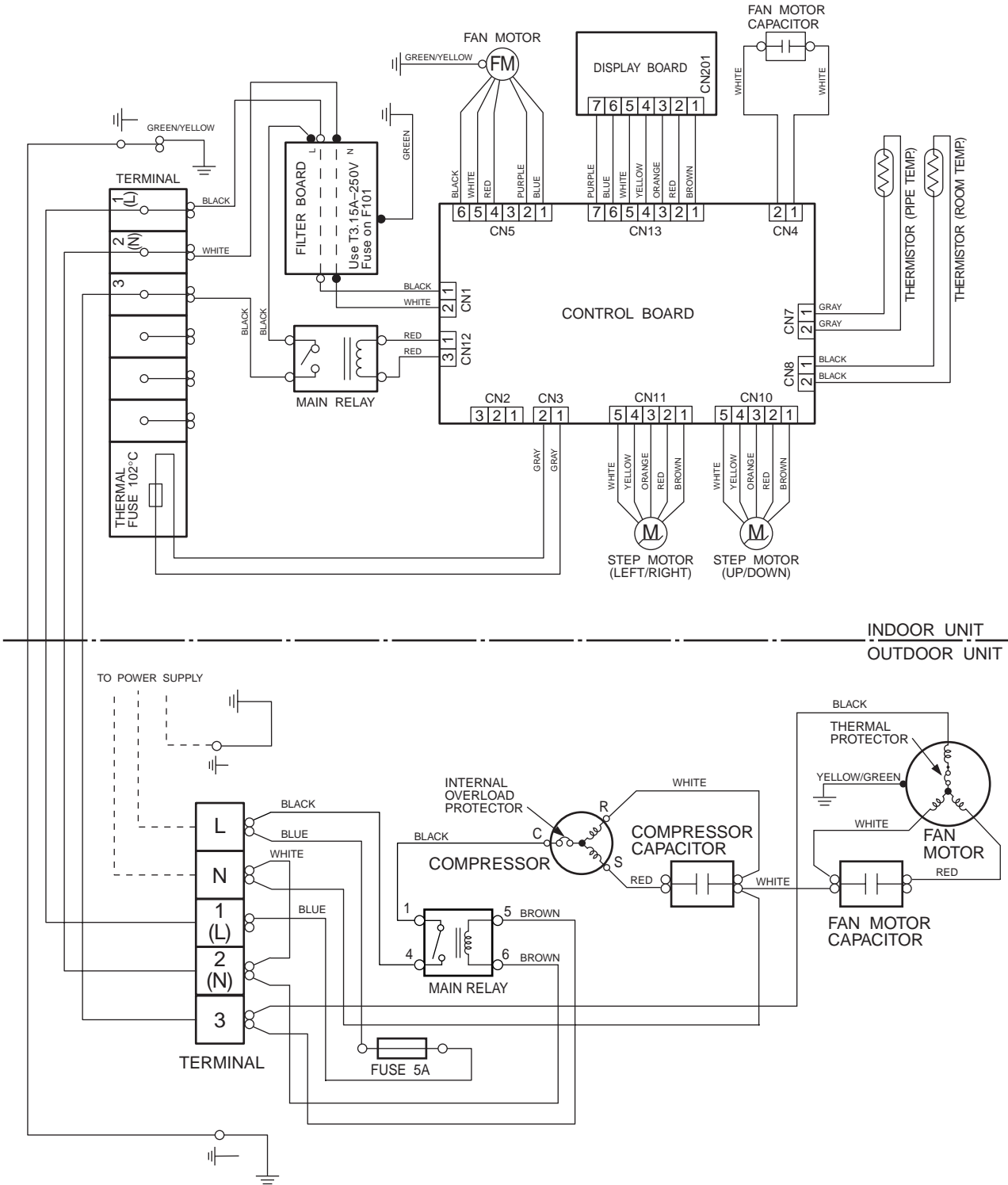

INDOOR PRINTED CIRCUIT BOARD CIRCUIT DIAGRAM

Models : RSW-20AB
RSW-24AB

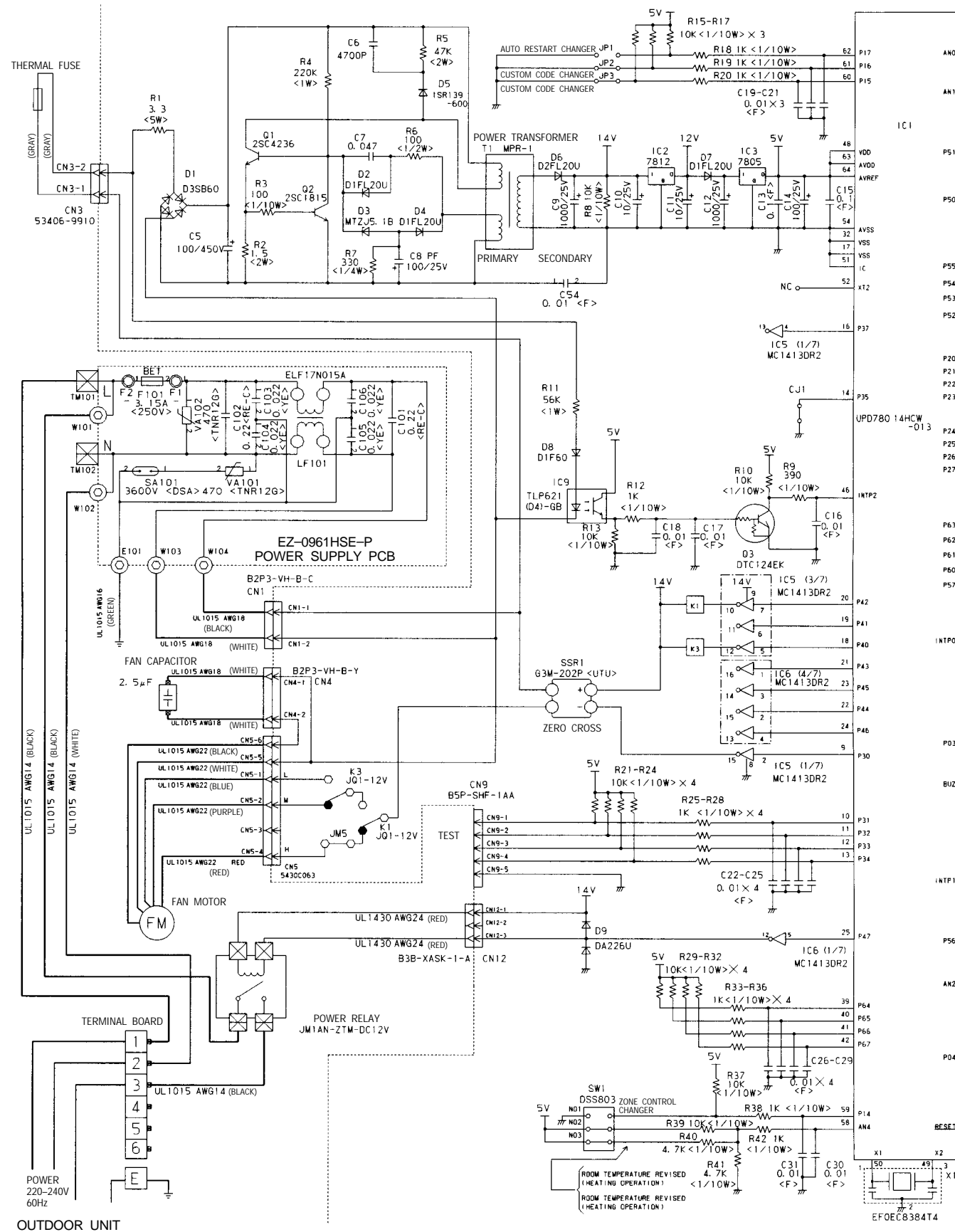

CONTROLLER PCB ASSEMBLY (MAIN PCB) EZ-0968WSE-C

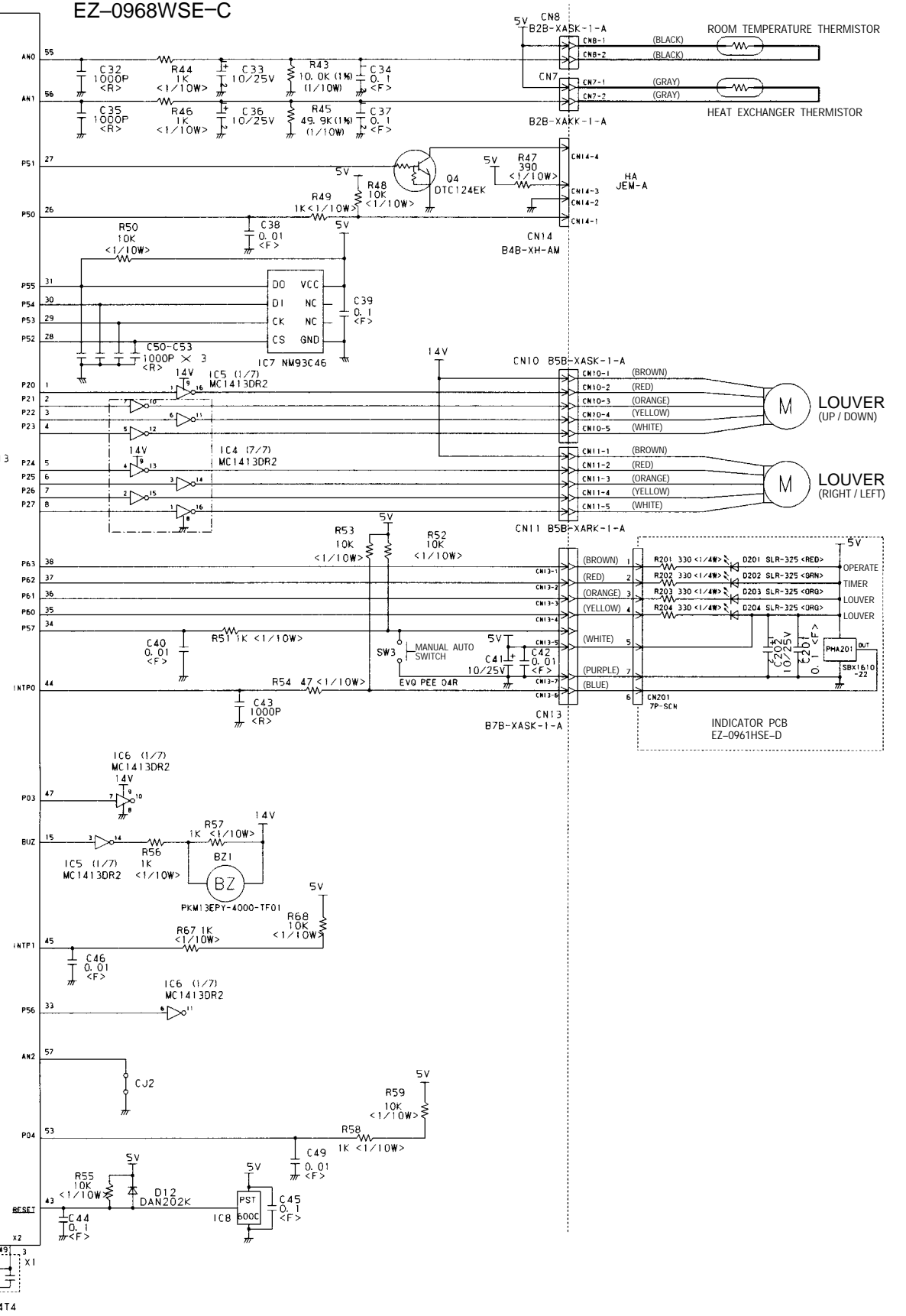

P.C. BOARD LAYOUTS

CONTROLLER P.C. BOARD ASSEMBLY

(Viewed from the solder side)

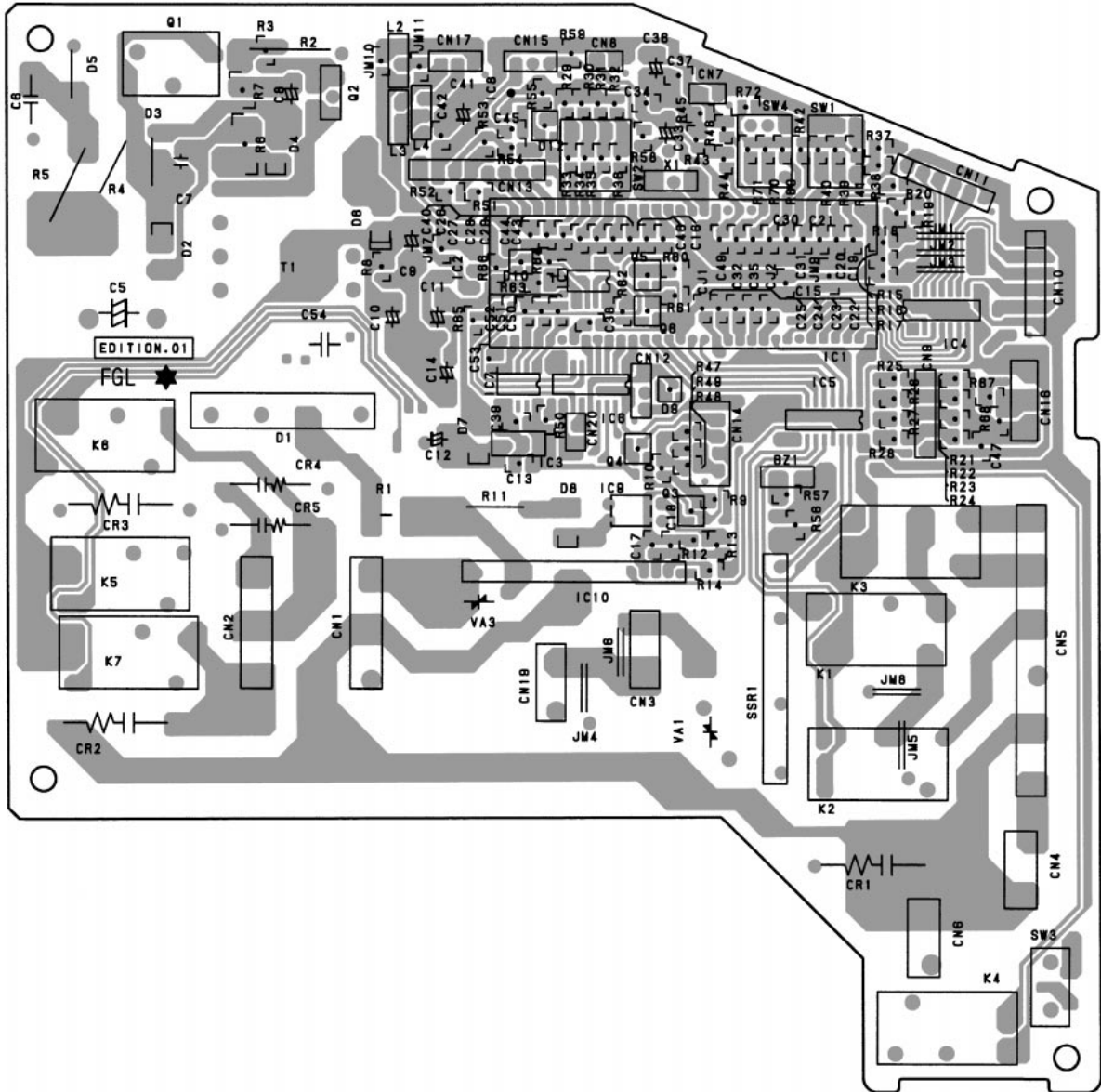

INDICATOR P.C. BOARD ASSEMBLY

(Viewed from the solder side)

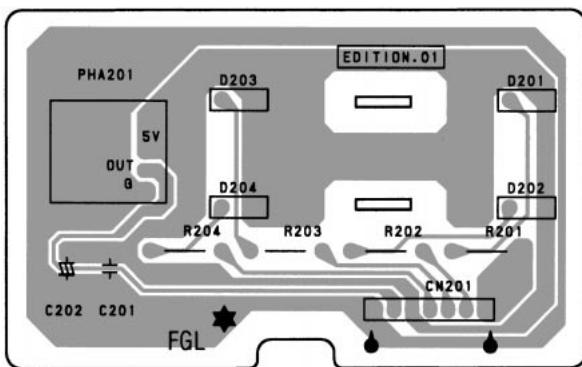

FILTER P.C. BOARD ASSEMBLY

(Viewed from the solder side)

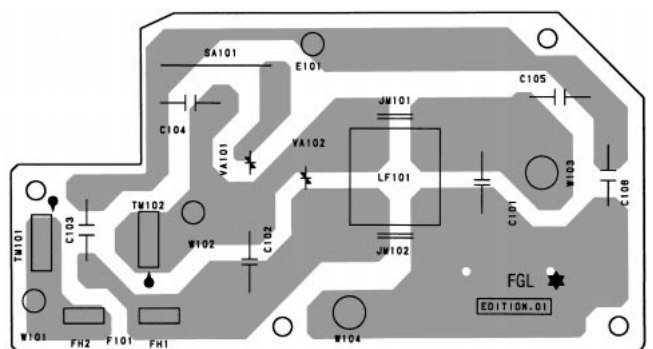

REMOTE CONTROL UNIT CIRCUIT DIAGRAM

Models : RSW-20AB
RSW-24AB

**KEY NO. : KEY FUNCTION
CORRESPONDENCE TABLE**

No.	KEY FUNCTION
S1	ACL
S2	TIMER ADJUST
S3	TEST RUN
S4	START / STOP
S5	MASTER CONTROL
S6	SET TEMP. (+) SET TIME (+)
S7	SET TEMP. (-) SET TIME (-)
S8	FAN CONTROL
S9	
S10	
S11	UP AND DOWN SWING
S12	UP AND DOWN WIND
S13	ENERGY SAVE
S14	RIGHT AND LEFT SWING
S15	TIMER SELECTOR
S16	SLEEP
S17	RIGHT AND LEFT WIND

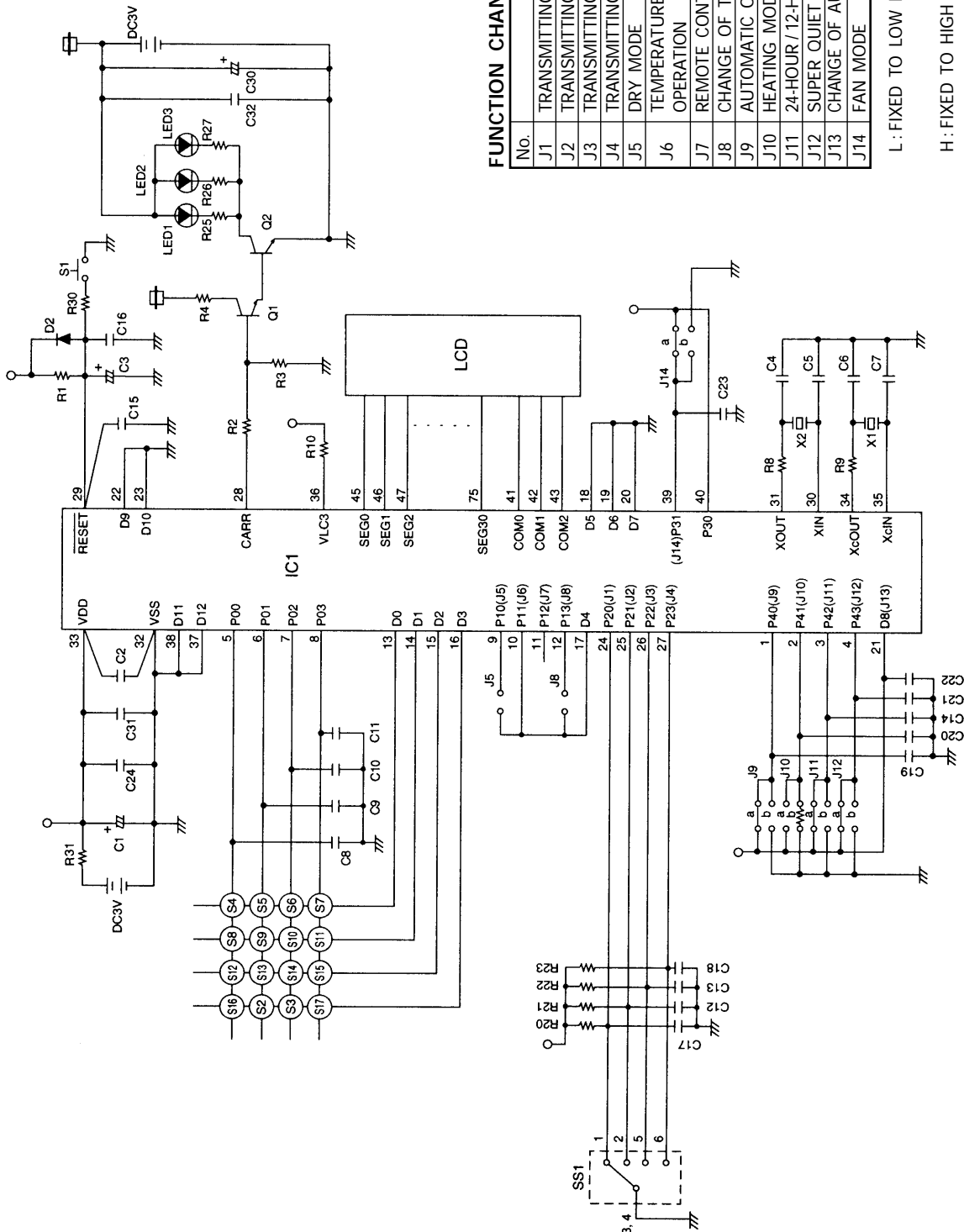

FUNCTION CHANGE BY THE JUMPER WIRE

No.	FUNCTION
J1	TRANSMITTING CODE CHANGE
J2	TRANSMITTING CODE CHANGE
J3	TRANSMITTING CODE CHANGE
J4	TRANSMITTING CODE CHANGE
J5	DRY MODE
J6	TEMPERATURE DISPLAY OF AUTOMATIC OPERATION
J7	REMOTE CONTROL SELECTOR
J8	CHANGE OF TEMPERATURE UNIT
J9	AUTOMATIC OPERATION
J10	HEATING MODE
J11	24-HOUR / 12-HOUR
J12	SUPER QUIET
J13	CHANGE OF AUTOMATIC OPERATION DISPLAY
J14	FAN MODE

L : FIXED TO LOW LEVEL

H : FIXED TO HIGH LEVEL

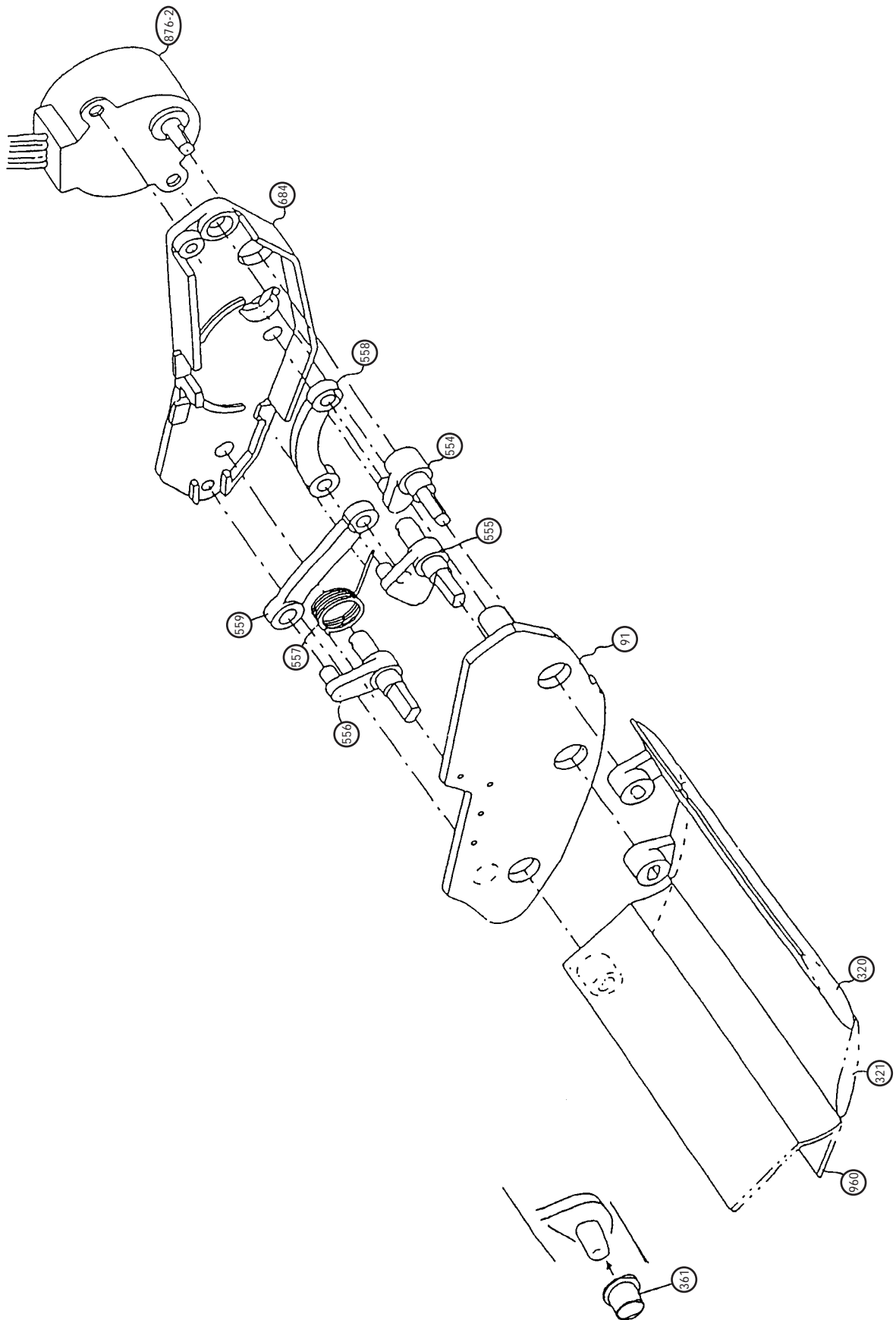

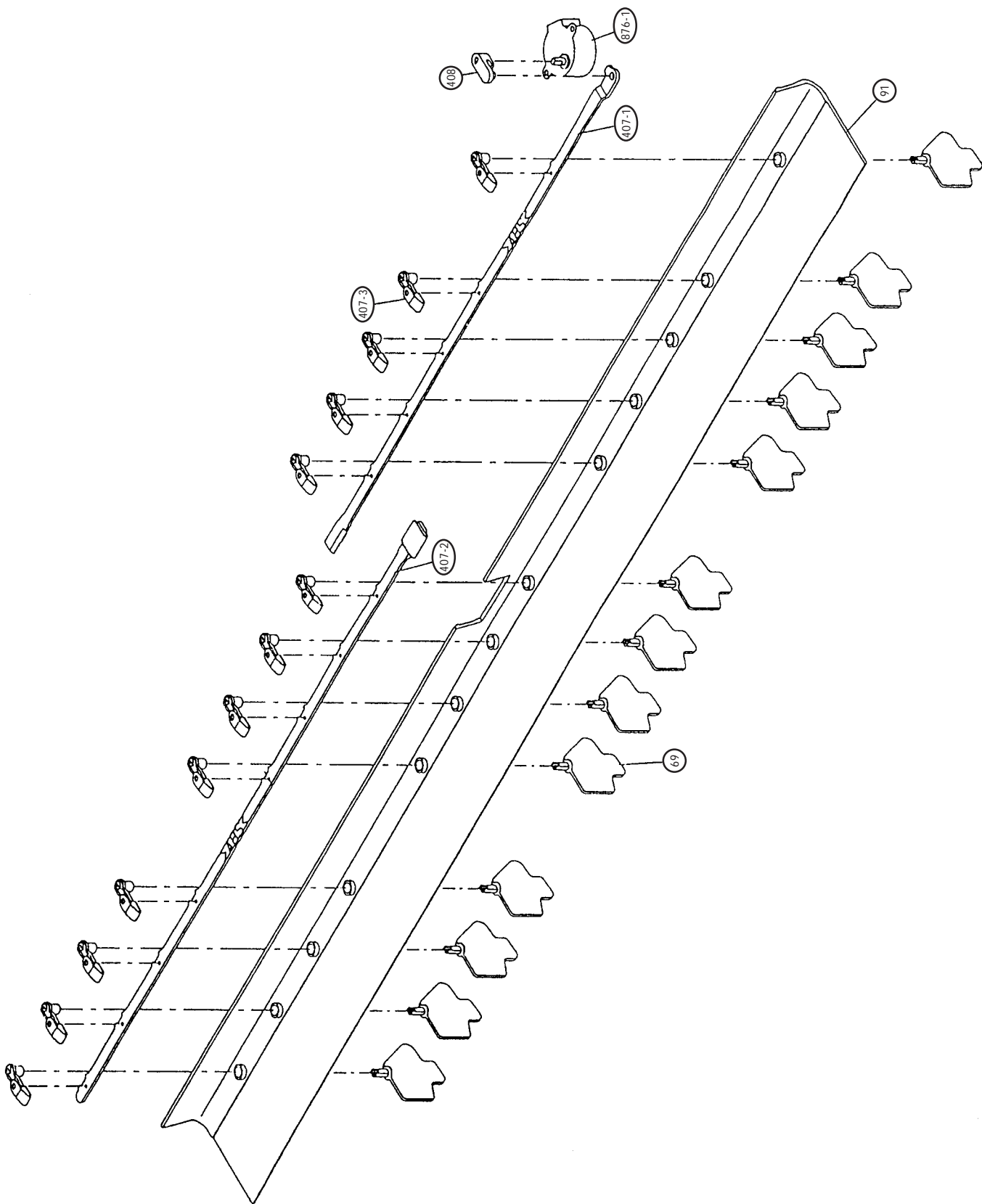

Models : ROW-20AB
ROW-24AB

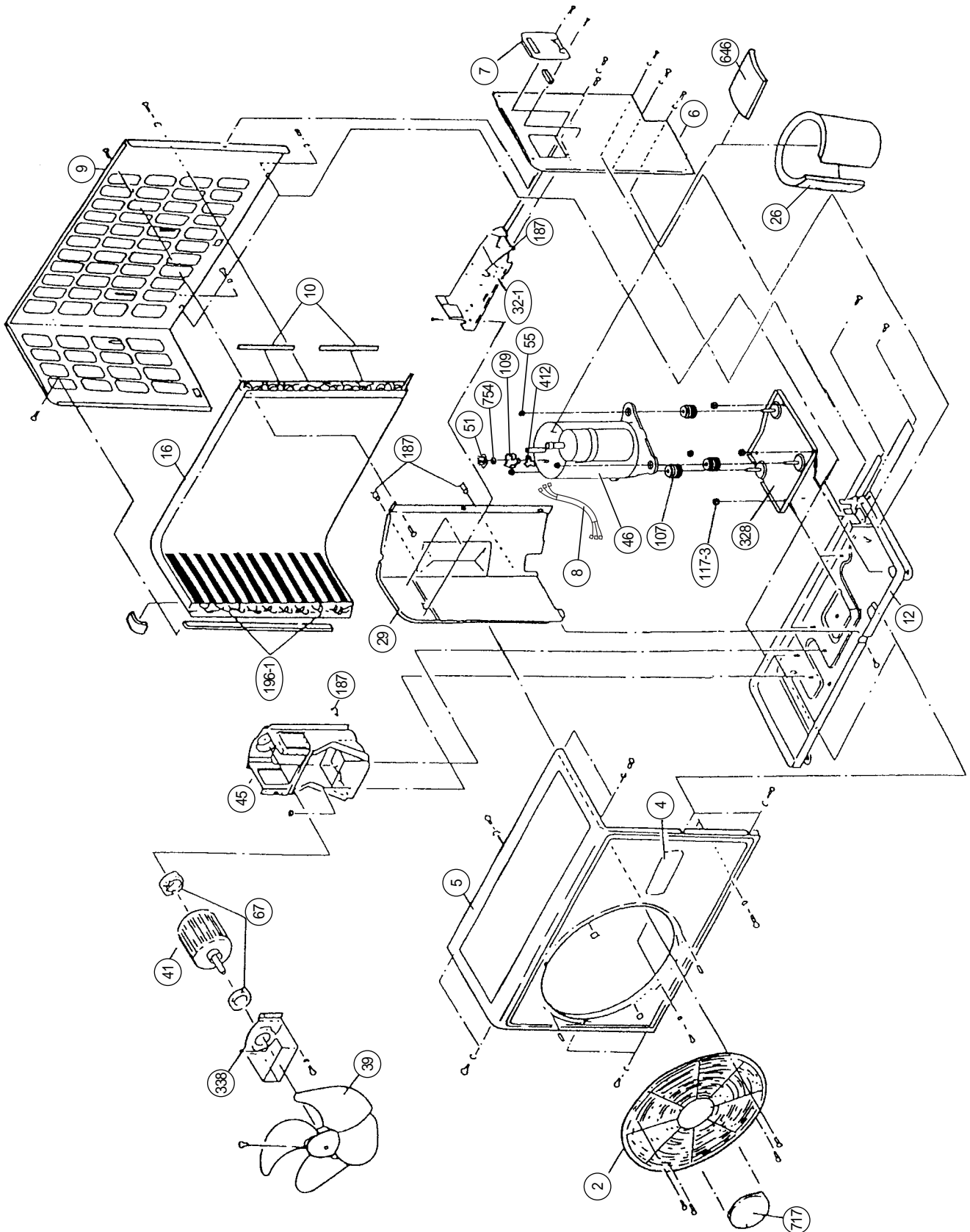

Model : ROW-20AB

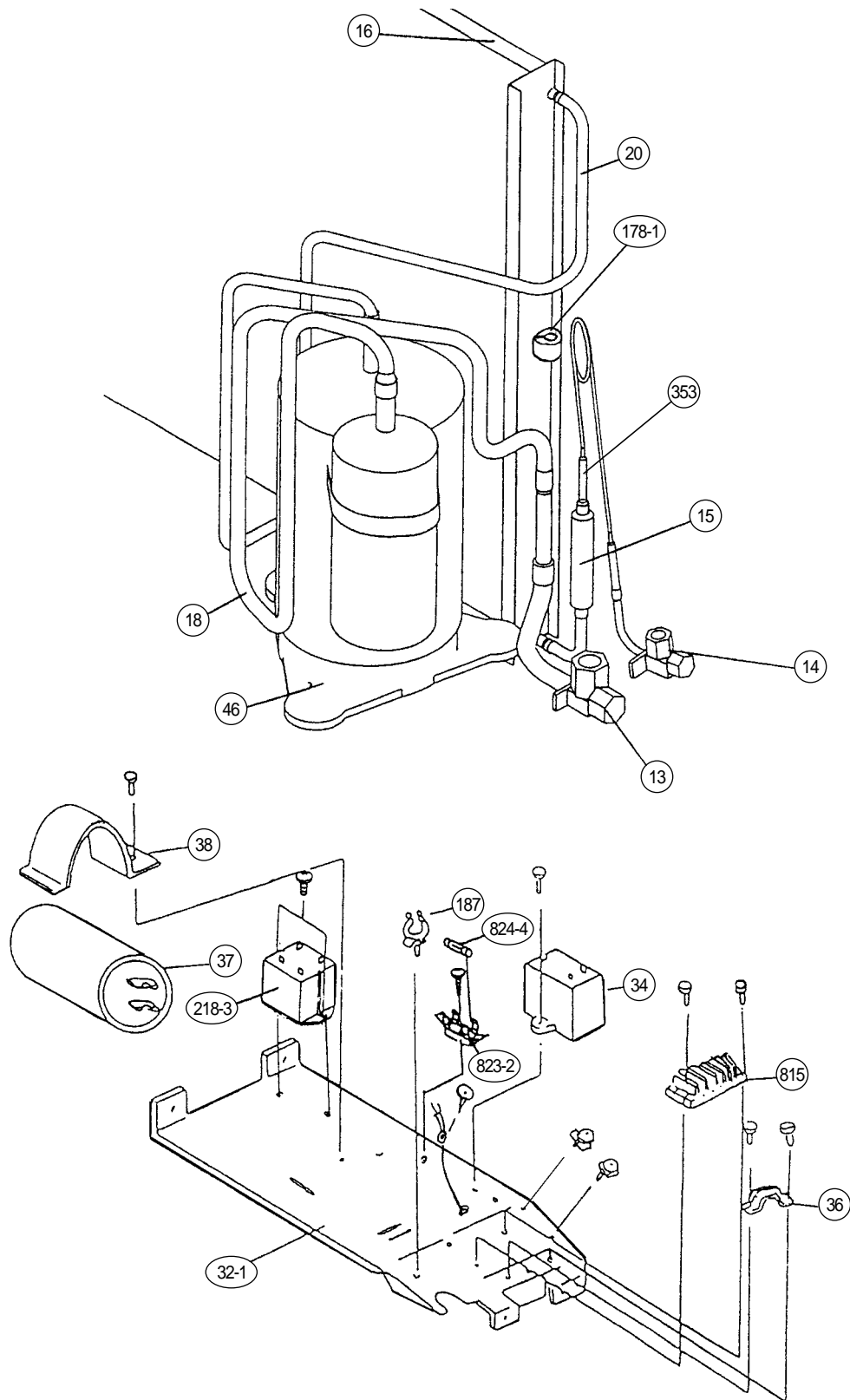

Model : ROW-24AB

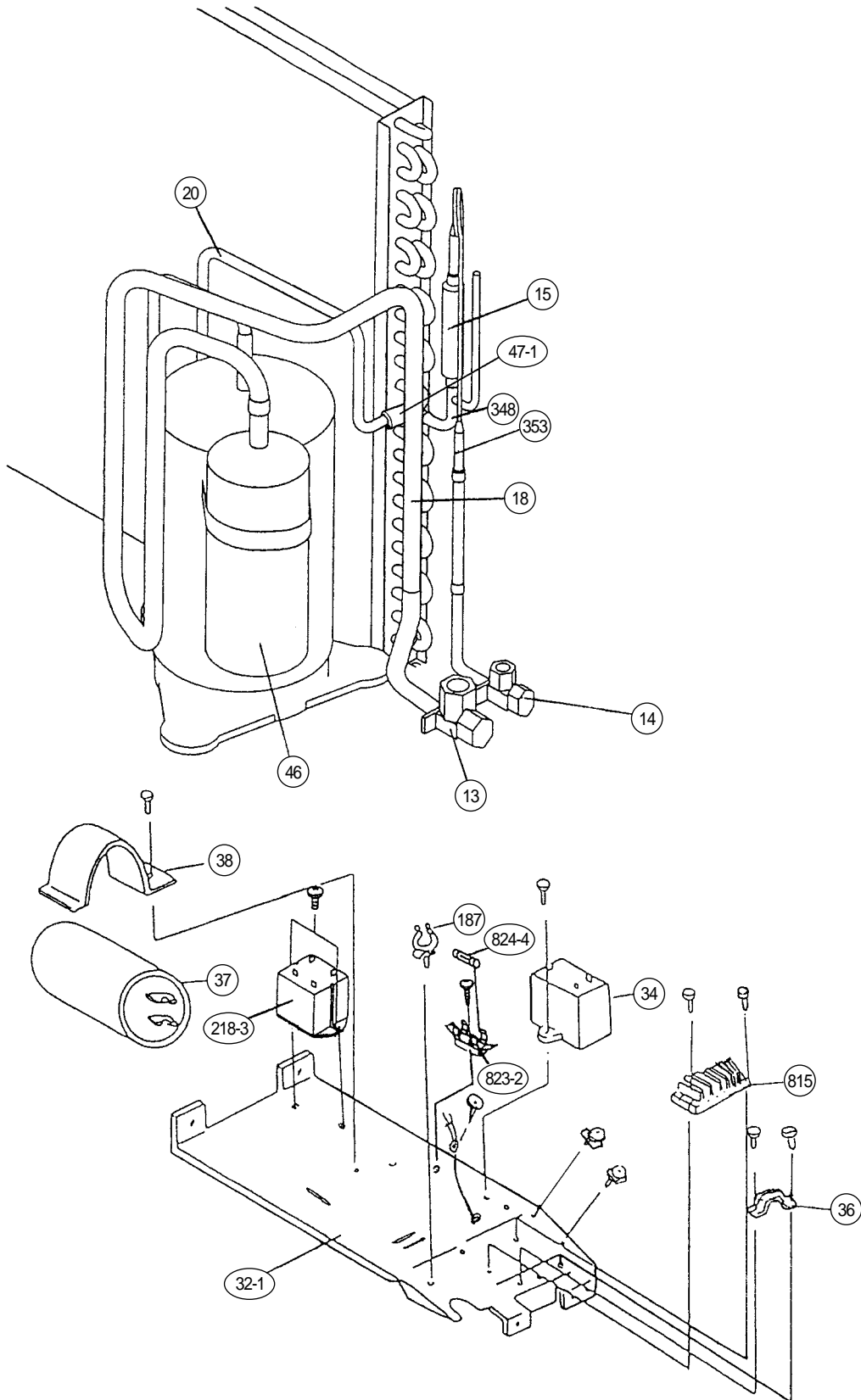

PARTS LIST

When you order parts, please make a photocopy of this page and fill the number of the parts in the "Order" column.

INDOOR UNIT

Ref. No.	Description	Part No.		Ord. Q'ty	Ref. No.	Description	Part No.		Ord. Q'ty
		RSW-20AB	RSW-24AB				RSW-20AB	RSW-24AB	
34	Capacitor (Fan Motor)	9700468073	9700468073		555	Flap Link-Lower	9357925004	9357925004	
63	Panel (Front) Total Assy	9358181041	9358181041		556	Diffuser Link	9357926001	9357926001	
67-2	Rubber-B	9361237001	9361237001		557	Diffuser Spring	9357947006	9357947006	
69	Louver	9357933016	9357933016		558	Rod-A	9357927008	9357927008	
91	Hinge Plate	9361281011	9361281011		559	Rod-B	9357928005	9357928005	
93	Air Filter	9357897011	9357897011		652-1	Thermistor Holder Pipe	313806262805	313806262805	
108	Base	9357948010	9357948010		679	Cover (Power)	9357916019	9357916019	
109	Casing	9361280014	9361280014		683	Balance Spring	9358151006	9358151006	
146	Evaporator Assy	9361995000	9361995000		684	Motor Base	9357929002	9357929002	
158	Joint Pipe Assy-E	9364296005	9364296005		685	Cover (Terminal)	9357955001	9357955001	
164	Fan Motor-In	9358878019	9358642016		686	Holder (Relay)	9357960005	9357960005	
184-1	Thermistor Spring-A	313728262708	313728262708		743	Remote Control Unit Holder	9359955016	9359955016	
210	Main Relay	9356781007	9356781007		755	Cover (Casing)-L	9363786019	9363786019	
223	Control Box	9357953007	9357953007		756	Cover (Casing)-B	9363787016	9363787016	
234	Thermistor Assy-Room	9703299018	9703299018		759	Intake Grille-F	9359024019	9359024019	
235	Thermistor Assy-Pipe	9701947010	9701947010		761	Cover (Side)-R	9357901022	9357901022	
236	Controller PCB Assy	9701941025	9701941025		762	Cover (Side)-L	9357902029	9357902029	
240	Remote Control Unit	9359913061	9359913061		767-1	Bottom Cover-A	9357949017	9357949017	
273	Holder (Lamp)	9357958002	9357958002		767-2	Bottom Cover-B	9357950013	9357950013	
320	Flap (Upper)-G	9357937014	9357937014		776	Hook (Grille)-R	9357986012	9357986012	
321	Flap (Lower)	9357940014	9357940014		777	Hook (Grille)-L	9357985015	9357985015	
361	Bushing	9357942001	9357942001		815	Terminal-6P	9357954004	9357954004	
385	Indicator PCB Assy	9701869015	9701869015		850	Receiver Window	9357917016	9357917016	
394	Bracket Panel (Pipe)	9357951003	9357951003		875	Filter PCB Assy	9702017026	9702017026	
401	Bracket Panel	9357952000	9357952000		876-1	Step Motor-H	9359763000	9359763000	
407-1	Motor Rod	9357931005	9357931005		876-2	Step Motor-V	9359762003	9359762003	
407-2	Louver Rod	9357932002	9357932002		925	Panel (Eva. Right)-B	9357909004	9357909004	
407-3	Louver Stopper	9357934006	9357934006		938	Cover (Switch)	9357956015	9357956015	
408	Louver Link	9357935003	9357935003		958	Bracket Panel (Eva.)	9358626009	9358626009	
425	Earth Plate	9357957005	9357957005		960	Diffuser	9357941011	9357941011	
431	Fixture-A	313546156408	313546156408		963	Fan Guard	9357936000	9357936000	
554	Flap Link-Upper	9357924007	9357924007		976	Display Window	9357903019	9357903019	

When you order parts, please make a photocopy of this page and fill the number of the parts in the "Order" column.

OUTDOOR UNIT

Ref. No.	Description	Part No.		Ord. Q'ty	Ref. No.	Description	Part No.		Ord. Q'ty
		ROW-20AB	ROW-24AB				ROW-20AB	ROW-24AB	
2	Fan Cover	9350214020	9350214020		34	Capacitor (Fan Motor)	9357965017	9357965017	
4	Emblem-Rear "FUJI"	9301702019	9301702019		36	Cord Holder Metal	9356934007	9356934007	
5	Cabinet-A, Painted	9303876015	9303876015		37	Running Capacitor	9703107016	9703107016	
6	Cabinet-C, Painted	9353549013	9353549013		38	Capacitor Clamp Metal	9351770013	9351770013	
7	Connector Cover	9358011010	9358011010		39	Propeller Fan Assy	9300855013	9300855013	
8	Wire Assy (Shield)-D	9359904076	9359904076		41	Fan Motor Assy-Out	9600738023	9600738023	
9	Cabinet-B, Painted	9303874011	9303874011		45	Motor Fixing Table Assy	313029311100	313029311100	
10	Noise Insulation-E	313791106305	313791106305		46	Compressor Assy	9363446005	9363019001	
12	Base Assy, Painted	9353452054	9353452054		47-1	Rubber (Discha. Pipe)	---	313194159807	
13	3-Way Valve Assy	9364523002	9364523002		55	Special Nut M8	313252257701	313252257701	
14	2-Way Valve Assy	9365021002	9365021002		67	Rubber (Vibration-proof)	313659068604	313659068604	
15	Dryer	9353789006	9353789006		107	Rubber Seat-A (For Comp.)	9351049010	9351049010	
16	Condenser Assy	9353455055	9356015010		109	Terminal Cover (For Comp.)	9351048013	9351048013	
18	Suction Pipe	9364274003	9363043013		178-1	Capillary Holder Rubber	313414274807	---	
19	Capillary Tube	9364270005	---		187	Clamp No. 1219	313361271706	313361271706	
19-2	Joint Pipe	9354268005	9354268005		196-1	Clamp SKB-3M	---	312300787605	
20	Discharge Pipe Assy	9364271002	9363042016		338	Motor Fixture Metal	313029297108	313029297108	
21	Discharge Pipe-B	---	9360411006		371	Process Pipe-B	313142082352	313142082352	
26	Compressor Cover-A	9363020007	9363020007		646	Compressor Cover-B	9363021004	9363021004	
28	Insulation (Fan Cover)	313791345206	313791345206		717	Center Plate	9351253011	9351253011	
29	Separate Wall	313986033213	313986033213		815	Terminal-5P	9356497021	9356497021	
32-1	Control Box Metal-A	9353595003	9353595003						

When you order parts, please make a photocopy of this page and fill the number of the parts in the "Order" column.

CONTROLLER PCB ASSEMBLY (Ref. No.236)

Ref. No.	Description	Part No.	Ord. Q'ty	Ref. No.	Description	Part No.	Ord. Q'ty
IC1	IC μ PD78014HCW-013	9702426026		C6	Cap. Plastic 4700pF	0300269091	
IC3	IC NJM 7805FA	0100462081		SW3	Switch, Push EVQ-PFE-04R	9700891017	
IC4-6	IC μ PA2003GR	0100028041		T1	Switching Transformer ETS28AS118AH	9702727017	
IC7	IC BR93LC46RF-E2	0100295016		CN1	Plug, PCB 5-1123724-2	0501321574	
IC8	IC PST600CMTR	0101461120		CN3	Plug, PCB 53406-9910	0500951048	
IC9	IC TLP621(D4)-GB	0000117074		CN4	Plug, PCB 2-1123724-2	0501321529	
Q1	Xstr 2SC4236	0000164047		CN5	Plug, PCB 5430C063	0500957026	
Q2	Xstr 2SC1815	0000002011		C7	Cap. Plastic 50V 0.047 μ F	0300169339	
Q3,4	Xstr DTC124EKA	0000936033		C8	Cap. Elec 25V 100 μ F	0301197560	
D1	Diode D3SB60	0000689045		C9	Cap. Elec 25V 1000 μ F	0301196495	
D2,4,7	Diode D1FL20U	0000746519		C10,33,36,41	Cap. Elec 25V 10 μ F	0301192312	
D3	Diode MTZJ5.1B	0000852166		C12	Cap. Elec 25V 1000 μ F	0301158264	
D5	Diode 1SR139-600	0000353120		C13,15,34,37, 39,44,45	Cap. Ceramic 50V 0.1 μ F	0300311752	
D6	Diode D2FL20U	0000906500		C14	Cap. Elec 25V 100 μ F	0301192350	
D8	Diode D1F60	0000208024		C16-31,38,40, 42,46,49	Cap. Ceramic 50V 0.01 μ F	0300311738	
D9	Diode DA226U	0000625036		C32,35,43, 50-53	Cap. Ceramic 50V 1000pF	0300308509	
D12	Diode DAN202K	0000684019		C54	Cap. Ceramic 0.01 μ F	0300727539	
R1	Res. Cement 3.3 Ω \pm 10%	0200153148		R40,41	Res. 4.7k Ω \pm 5%	0200212906	
R2	Res. Metal 1.5 Ω \pm 5%	0201107119		R43	Res. 10k Ω \pm 1%	0200279497	
R3	Res. 100 Ω \pm 5%	0200212500		R45	Res. 49.9k Ω \pm 1%	0200279824	
R4	Res. Carbon 220k Ω \pm 5%	0200111353		R54	Res. 47 Ω \pm 5%	0200212425	
R5	Res. Metal 47k Ω \pm 5%	0201107652		X1	Ceramic Resonator EFOEC8384T4	9701261017	
R6	Res. 100 Ω \pm 5%	0200731506		BZ1	Buzzer PKM13EPY-4000-TF01	9701298013	
R7	Res. 330 Ω \pm 5%	0200708621		K1,3	Relay JQ1-12V	9701316014	
R8,10,13,15-17, 21-24,29-32, 37,39,48,50, 52,53,55,59,68	Res. 10k Ω \pm 5%	0200213019		SSR1	Relay G3M-202P-UTU	9701829019	
R9,47	Res. 390 Ω \pm 5%	0200212647		CN7	Plug, PCB B2B-XAKK-1-A	0501045227	
R11	Res. Metal 56k Ω \pm 5%	0201106662		CN8	Plug, PCB B2B-XASK-1-A	0501045012	
R12,18-20,25- 28,33-36,38, 42,44,46,49, 51,56-58,67	Res. 1k Ω \pm 5%	0200212746		CN9	Plug, PCB B5P-SHF-1AA	0500006069	
CJ1,2,JM7	Res. 0 Ω	0200212012		CN10	Plug, PCB B5B-XASK-1-A	0501045043	
JM9	Res. 0 Ω	0200230016		CN11	Plug, PCB B5B-XARK-1-A	0501045517	
C5	Cap. Elec 450V 100 μ F	0300256060		CN12	Plug, PCB B3B-XASK-1-A	0501045029	
				CN13	Plug, PCB B7B-XASK-1-A	0501045067	
				CN14	Plug, PCB B4B-XH-AM	0500005314	

INDICATOR PCB ASSEMBLY (Ref. No.385)





Ref. No.	Description	Part No.	Ord. Q'ty
D201	Diode SLR-325VC RED	0000813259	
D202	Diode SLR-325MC GRN	0000813242	
D203,204	Diode SLR-325DC ORG	0000813235	
C201	Cap. Ceramic 0.1 μ F	0300988251	
C202	Cap. Elec. 25V 10 μ F	0300004258	
R201-204	Res. Carbon 1/4W 330 Ω \pm 5%	0201038659	
PHA201	Remote Control Amplifier SBX1810-22	0101525129	
CN201	Wire/Connector L=430 Lamp Holder	9701856015 9357958002	

FILTER PCB ASSEMBLY (Ref. No.875)

Ref. No.	Description	Part No.	Ord. Q'ty
C101,102	Cap. Plastic 0.22 μ F	0300304099	
C105,106	Cap. Plastic 0.022 μ F	0301052098	
SA101	Arrester DSA-362MA-05	0600168032	
VA101,102	Varistor TNR12G471K	0000038010	
F101	Fuse 2183.15	0600285210	
FH1,2	Fuse Holder PFC5000-0502	0500158072	
TM101,102	Plug Contact 86028	0500536016	
LF101	EMI Filter ELF17N015A	0400197119	
W101	Wire w/Terminal BLK L=120	9702060039	
W102	Wire w/Terminal WHT L=180	9702060046	
W103,104	Wire Assy 2P	9702080013	
E101	Wire w/Terminal GRN L=250	9701880010	

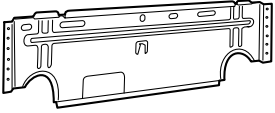
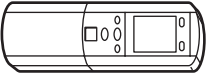
STANDARD ACCESSORIES

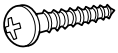
INDOOR UNIT ACCESSORIES

Name and Shape	Part No.
Wall hook bracket 	9357952000
Remote control unit 	9359913061 (AR-DL6)
Battery (penlight) 	0600185534
Remote control unit holder 	9359955016
Tapping screw (big) (ø4 x 20) 	301141164200
Tapping screw (small) (ø3 x 12) 	301141533125

OUTDOOR UNIT ACCESSORIES

Name and Shape	Part No.
Hexagon wrench 	9351228019



MANUFACTURER :

Fuji Denki Sosetsu Co., Ltd.

Tokyo, Japan