



**SPLIT TYPE
ROOM AIR CONDITIONER
WALL MOUNTED type**

**SERVICE
MANUAL**

Models

Indoor unit

Outdoor unit

RSB18LDC

ROS18LDC



CONTENTS

SPECIFICATIONS	1
DIMENSIONS	2
REFRIGERANT SYSTEM DIAGRAM	3
CIRCUIT DIAGRAM	4
INDOOR PCB CIRCUIT DIAGRAM	5
OUTDOOR PCB CIRCUIT DIAGRAM	8
ERROR CONTENTS.....	10
DISASSEMBLY ILLUSTRATION.....	11
PARTS LIST.....	15
STANDARD ACCESSORIES	17

SPECIFICATIONS

TYPE	COOL & HEAT INVERTER
INDOOR UNIT	RSB18LDC
OUTDOOR UNIT	ROS18LDC
COOLING CAPACITY	5.20 kW
HEATING CAPACITY	6.25 kW

ELECTRICAL DATA

POWER SOURCE	230 V	
FREQUENCY	50 Hz	
RUNNING CURRENT	COOLING	7.6 A
	HEATING	7.7 A
INPUT WATTS	COOLING	1.72 kW
	HEATING	1.73 kW
E.E.R.	COOLING	3.02 kW/kW
COP	HEATING	3.61 kW/kW
MOISTURE REMOVAL	2.8 L/hr	
AIR CIRCULATION HIGH	700 m ³ /hr	

COMPRESSOR

TYPE	Hermetic type, 4 pole, 3 phase, DC inverter motor, Rotary
DISCRIMINATION	DA130AIF - 25F
REFRIGERANT R410A	1,150 g

DIMENSIONS

INDOOR UNIT	H x W x D	283 x 790 x 230 mm
OUTDOOR UNIT	H x W x D	578 x 790 x 300 mm

WEIGHT

INDOOR UNIT	Gross / Net	12.5 kg / 10 kg
OUTDOOR UNIT	Gross / Net	44 kg / 40 kg

NOISE LEVEL

INDOOR UNIT (Cool / Heat)	High	45 dB / 42 dB
	Med	39 dB / 38 dB
	Low	33 dB / 33 dB
	Quiet	26 dB / 27 dB
OUTDOOR UNIT (Cool / Heat)		50 dB / 50 dB

REFRIGERANT (R410A)

Pipe Length	15 m	1,150 g
FULL CHARGE AMOUNT	20 m	1,250 g
ADDITIONAL REFRIGERANT		20 g/m
MAXIMUM PIPING HEIGHT		15m

DIMENSIONS

unit : mm

INDOOR UNIT

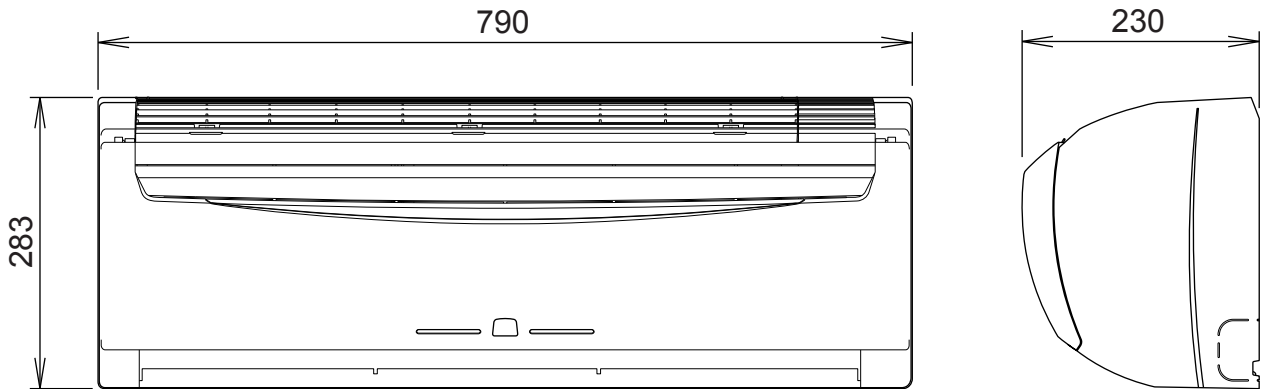

OUTDOOR UNIT

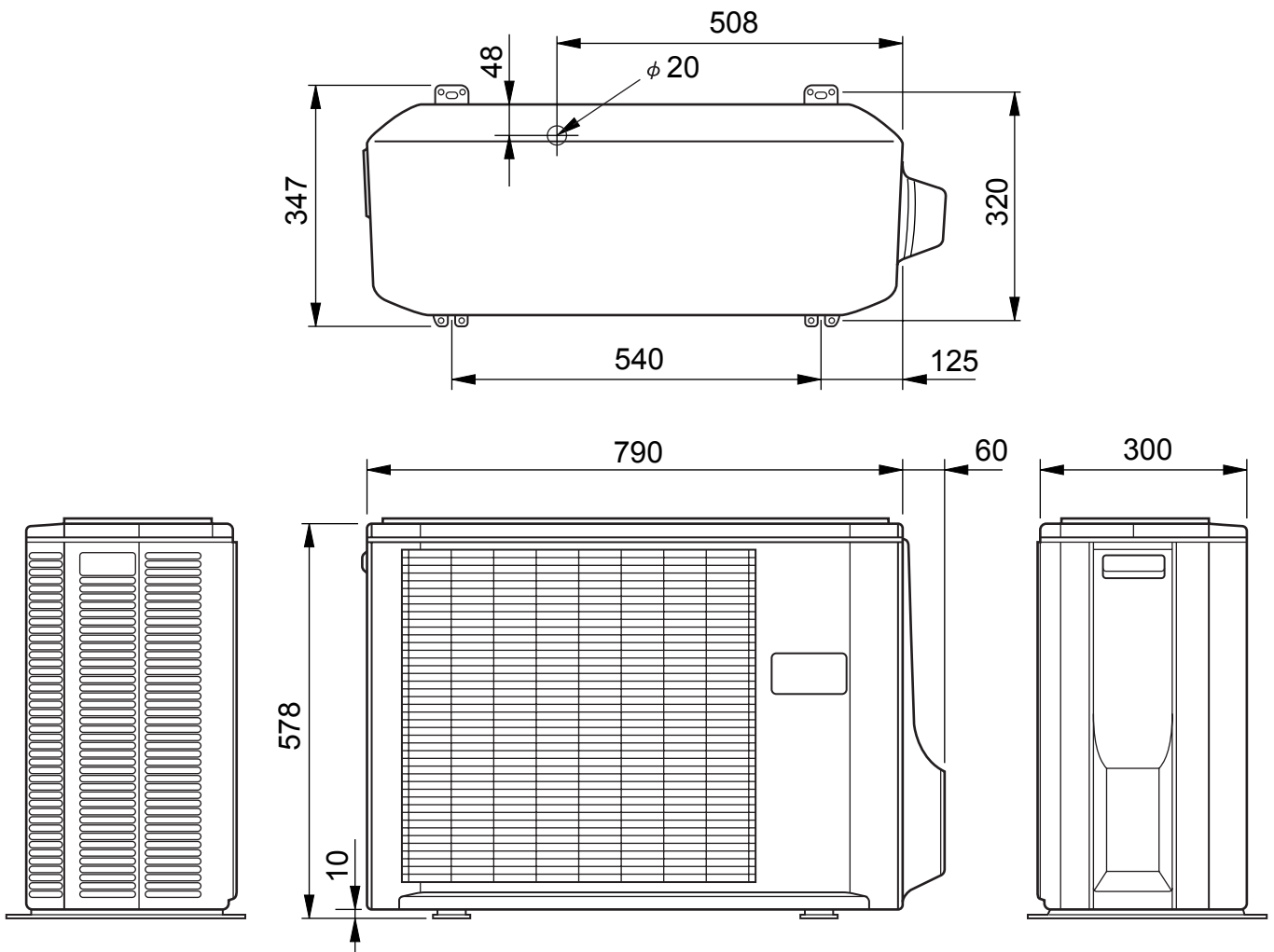

REFRIGERANT SYSTEM DIAGRAM

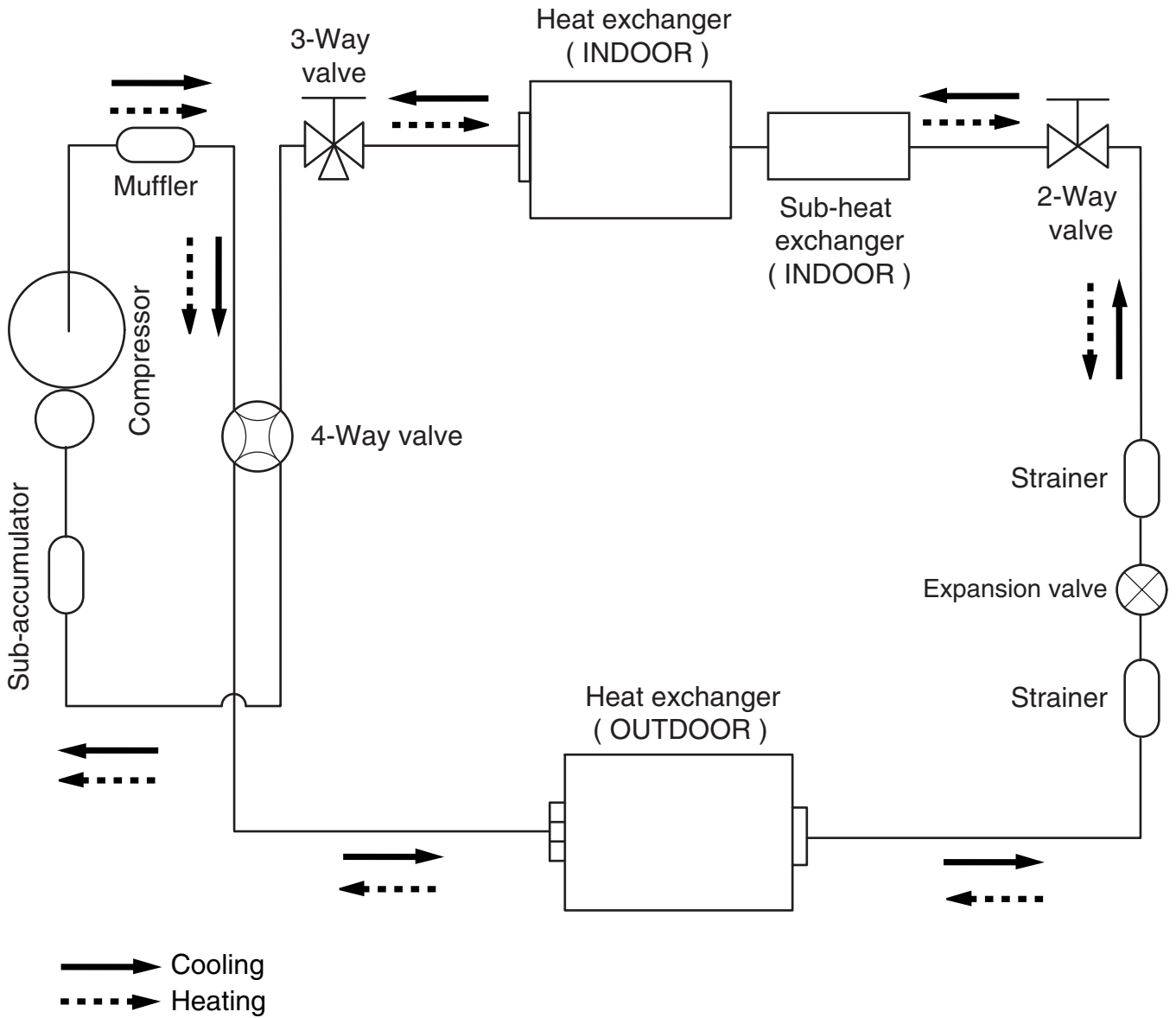

Refrigerant pipe diameter
 Liquid : 1/4" (6.35 mm)
 Gas : 1/2" (12.7 mm)

CIRCUIT DIAGRAM

INDOOR UNIT

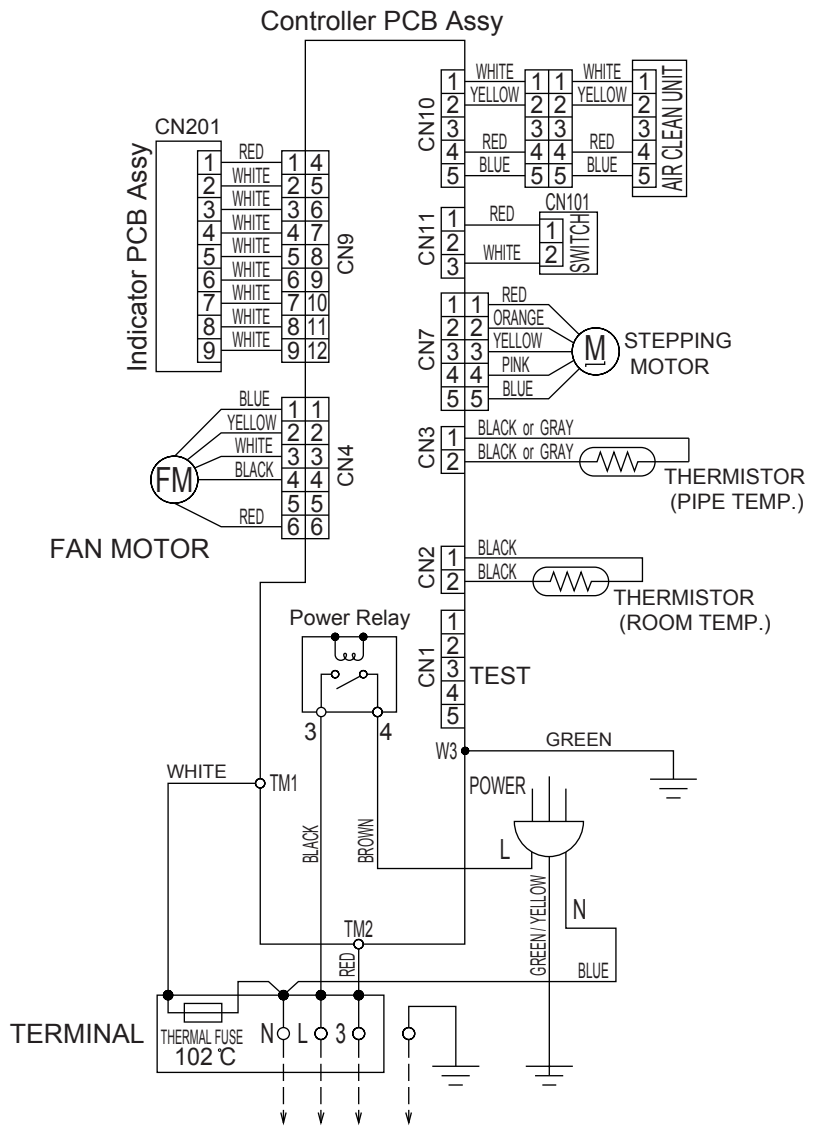

OUTDOOR UNIT

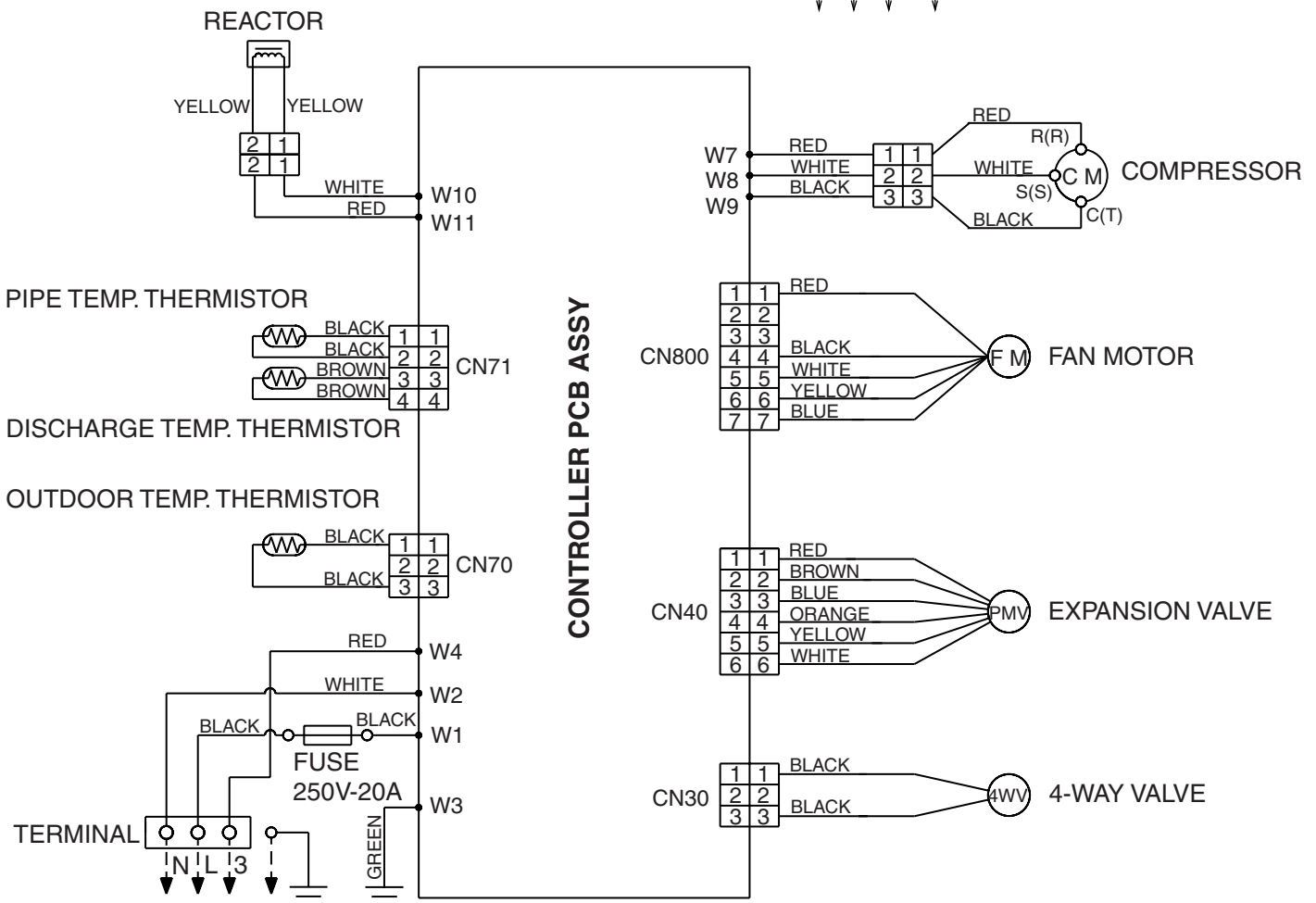

INDOOR PCB CIRCUIT DIAGRAM

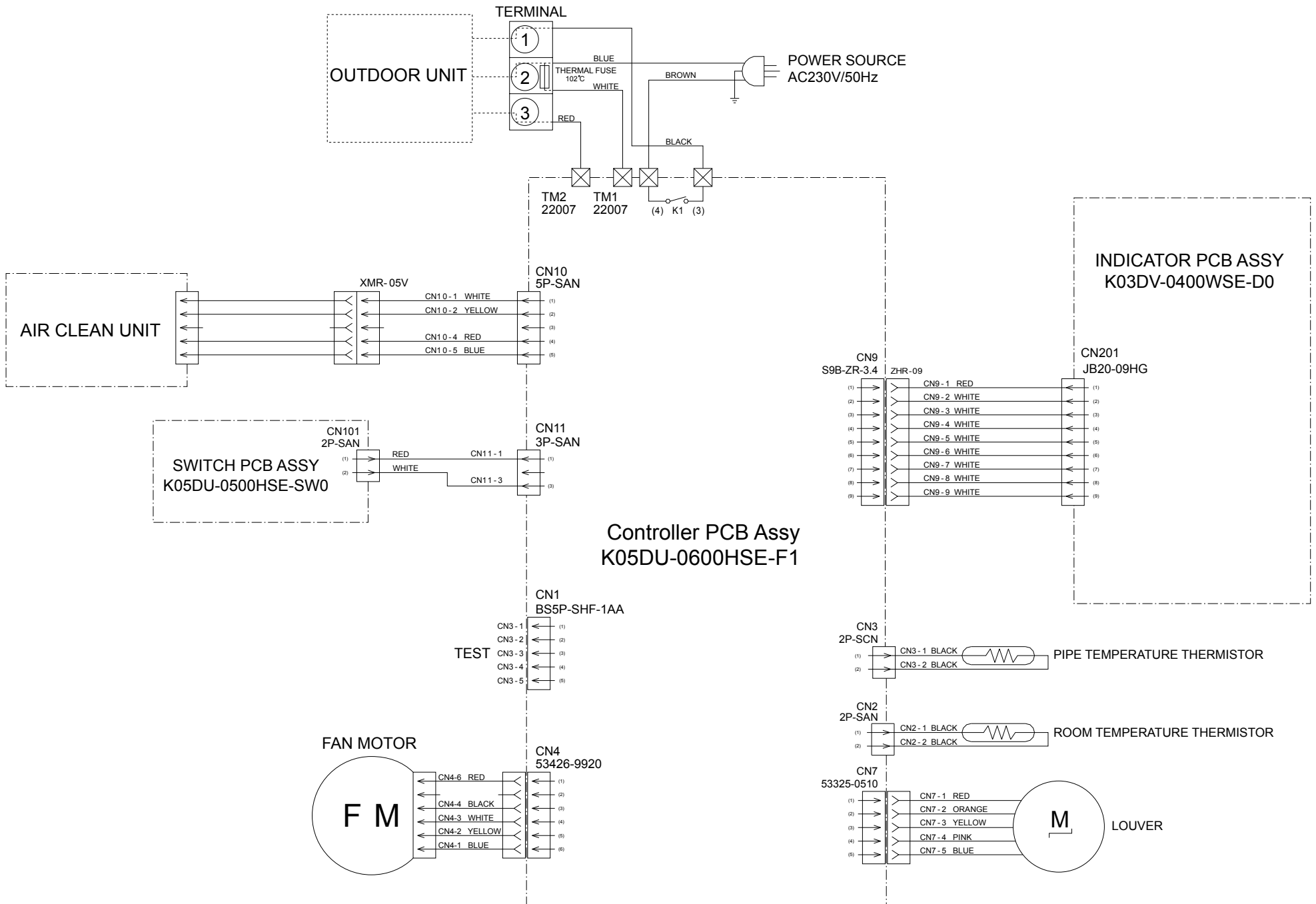

INDOOR UNIT
Controller PCB Assy
K05DU-0600HSE-F1

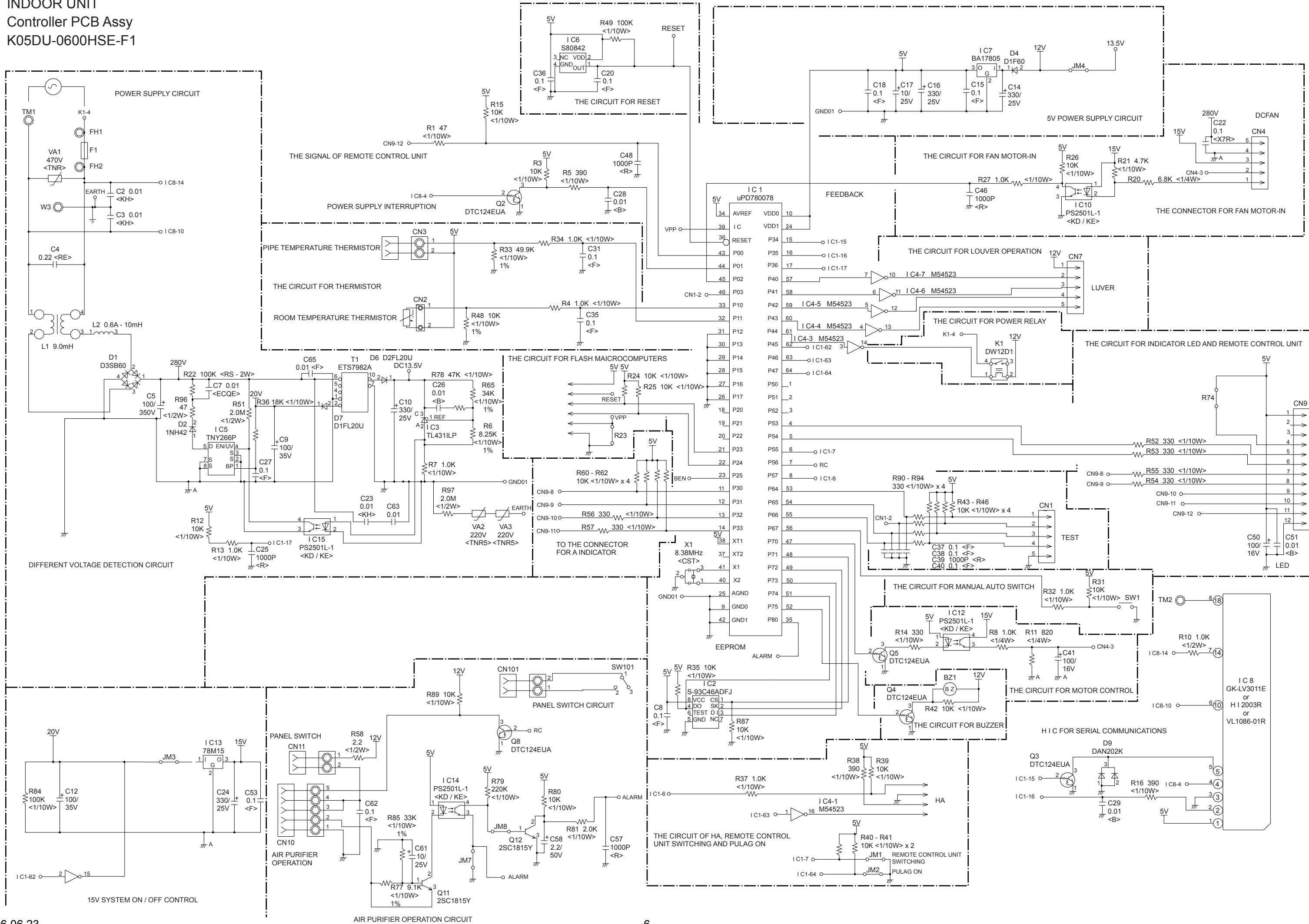

INDOOR UNIT

INDICATOR PCB ASSY
K03DV-0400WSE-D0

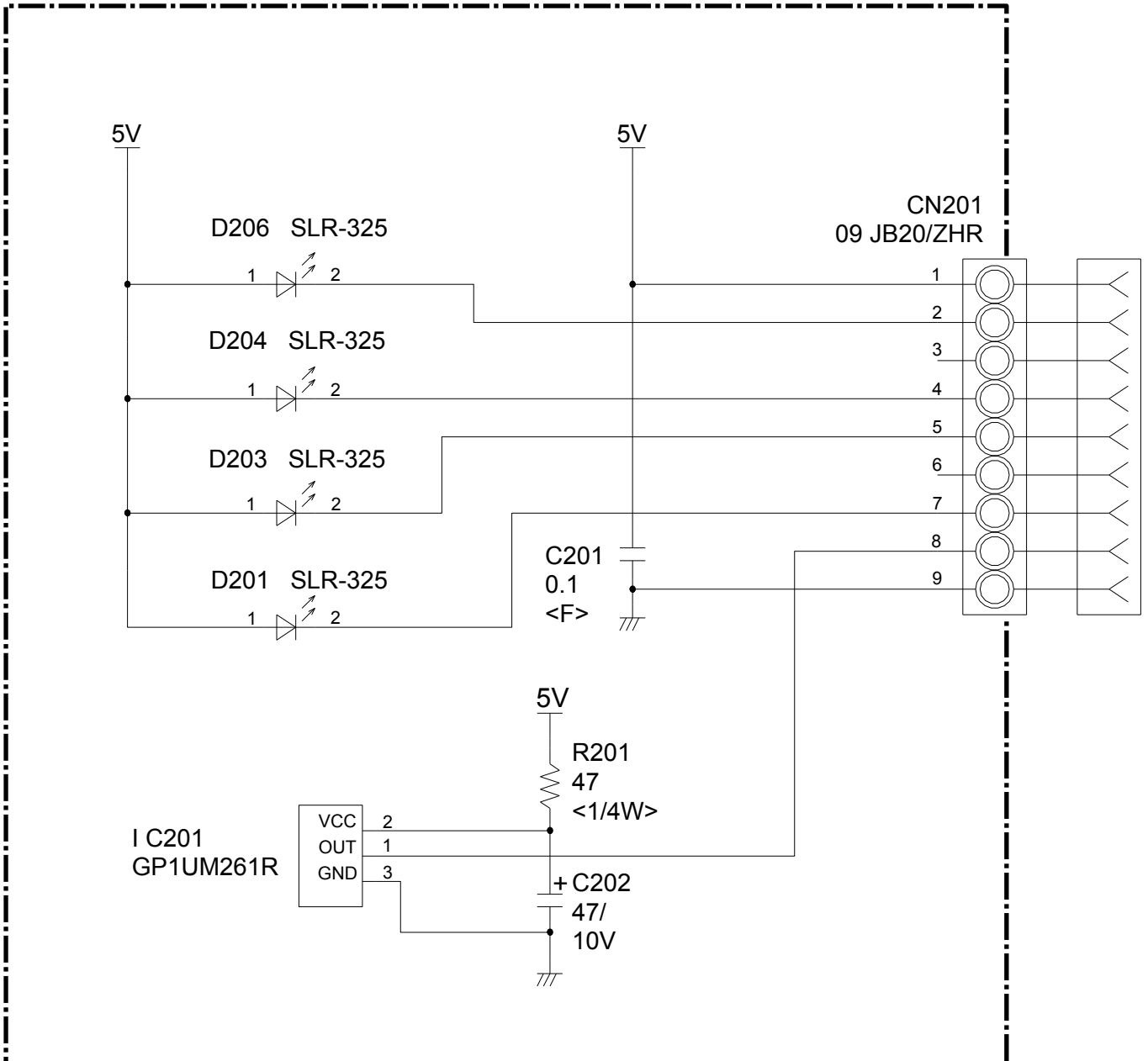

OUTDOOR PCB CIRCUIT DIAGRAM

Inverter Assy
EZ-006EHUE

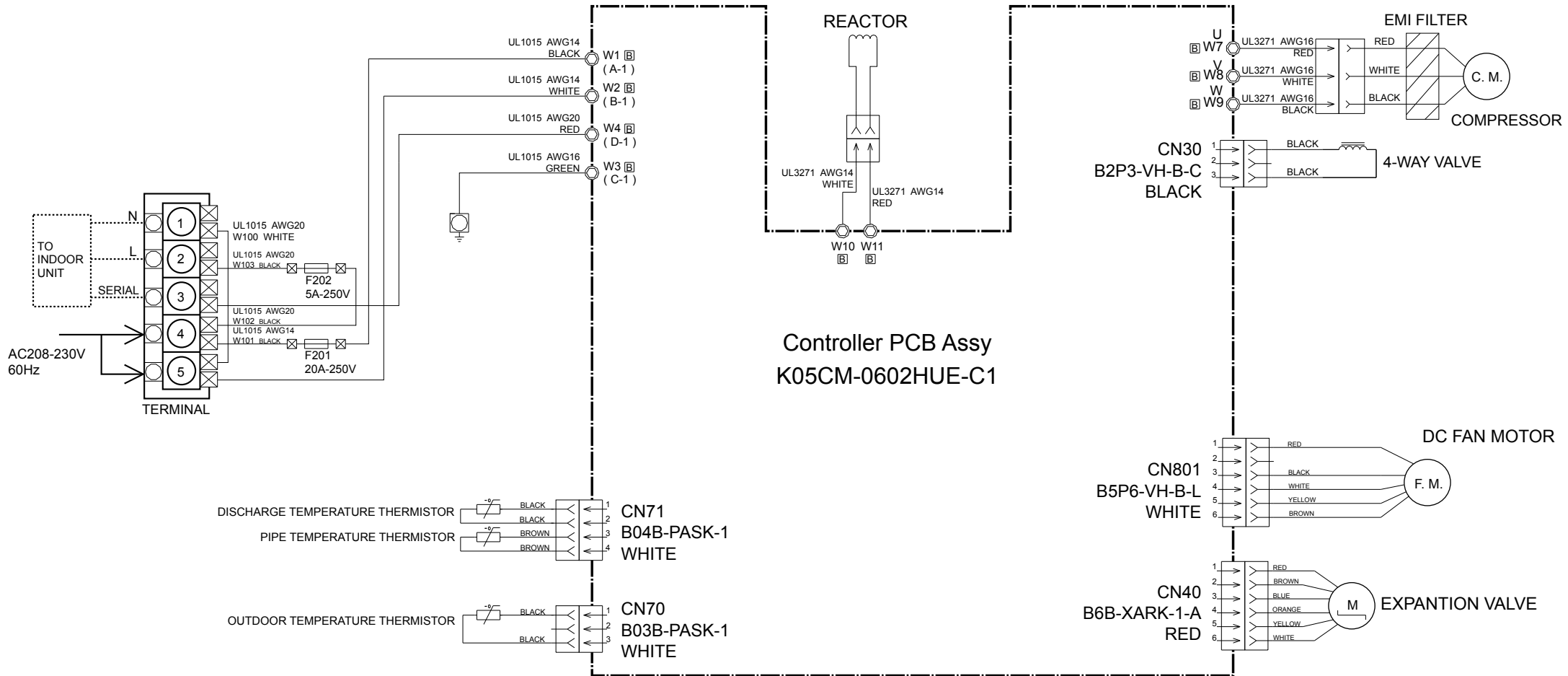

OUTDOOR UNIT
Controller PCB Assy
K05CM-0602HUE-C1

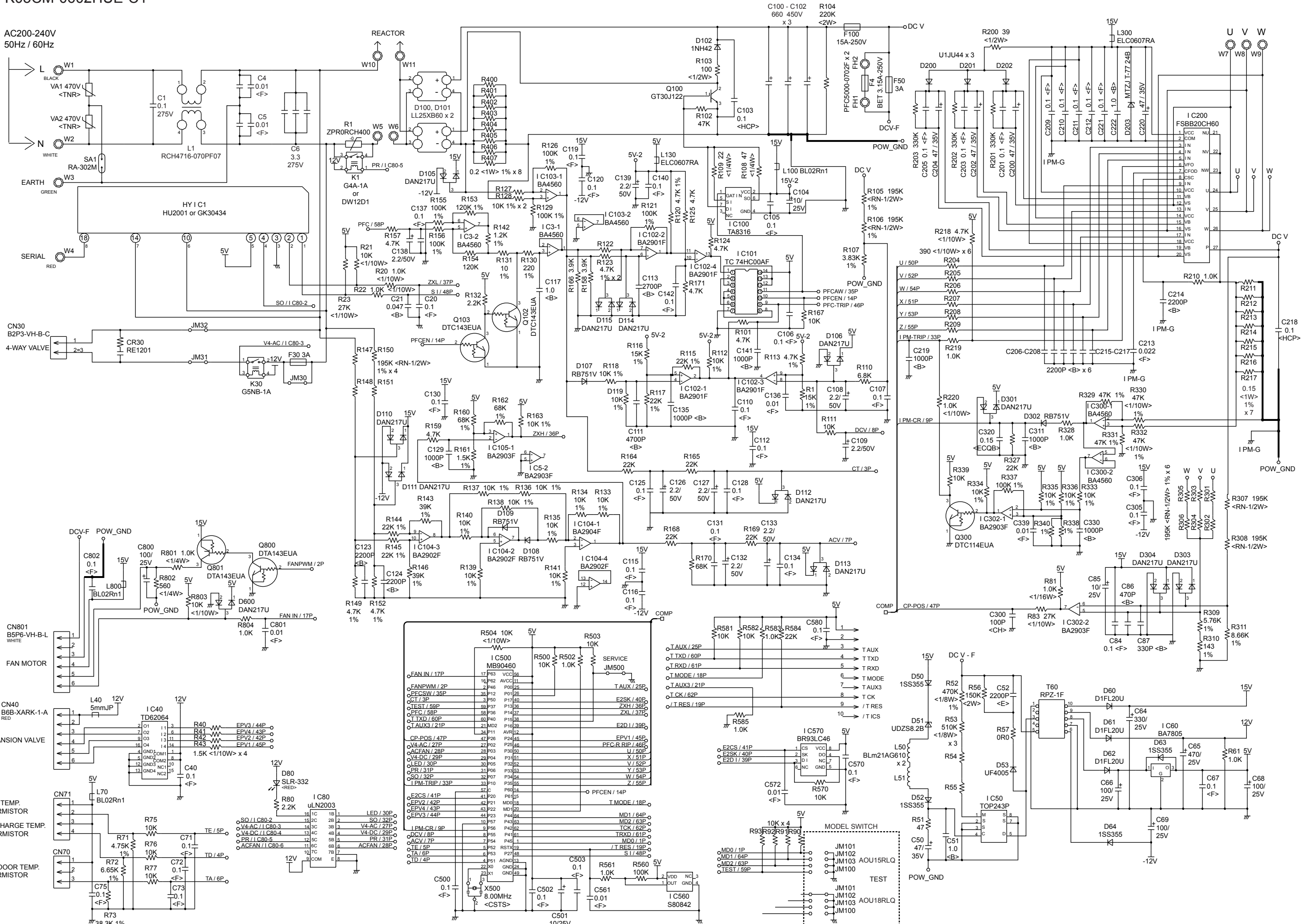

ERROR CONTENTS

Error	Display		Error
	Operation LED	Timer LED	
Serial signal error	Off	2 flash	Serial signal (reverse) error, at operation start up
		3 flash	Serial signal (reverse) error, during operation
		4 flash	Serial signal (forward) error, at operation start up
		5 flash	Serial signal (forward) error, during operation
Indoor unit thermistor error	2 flash	2 flash	Indoor temperature thermistor open / short
		3 flash	Heat exchanger middle thermistor open / short
Outdoor unit thermistor error	3 flash	2 flash	Discharge thermistor open / short
		3 flash	Heat exchanger thermistor open
		4 flash	Outdoor temperature thermistor open / short
Indoor unit control error	4 flash	2 flash	Forced automatic SW welded
		3 flash	Main relay welded
		4 flash	Power interruption error
		7 flash	VDD permanent stop protection
		8 flash	reverse VDD permanent stop protection
Outdoor unit control error	5 flash	2 flash	Current trip error
		3 flash	CT abnormal
		5 flash	Compressor location detection error
		6 flash	Outdoor unit fan drive system abnormal
Indoor fan motor error	6 flash	2 flash	Abnormal lock
		3 flash	Abnormal rotation
Refrigerant cycle error	7 flash	2 flash	Discharge Temperature abnormal
		3 flash	Cooling high pressure abnormal rise
Optional function error	8 flash	4 flash	PFC circuit error
Model information error	0.1 sec on/off	0.1 sec on/off	Model information error

DISASSEMBLY ILLUSTRATION

INDOOR UNIT

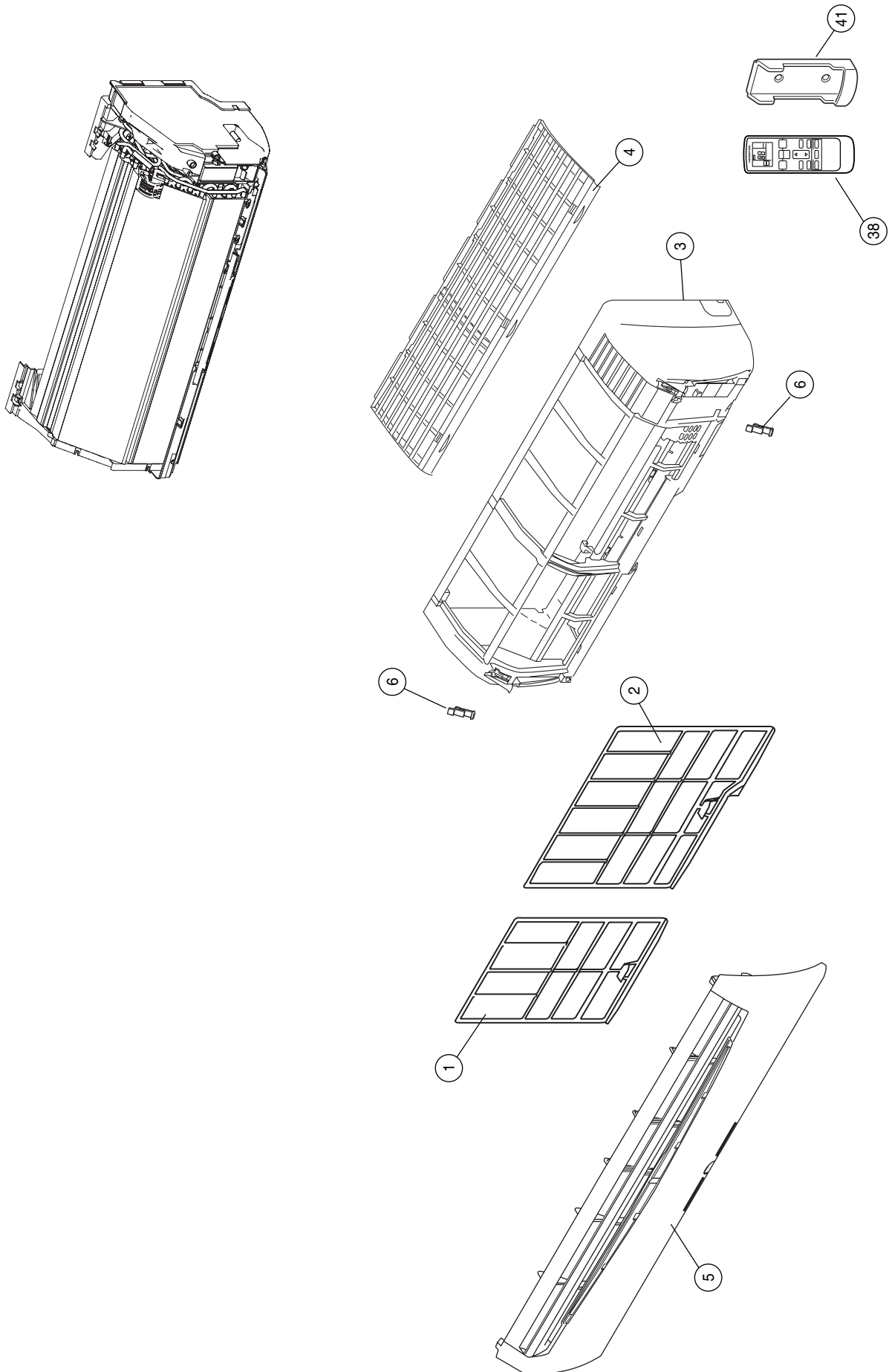

INDOOR UNIT

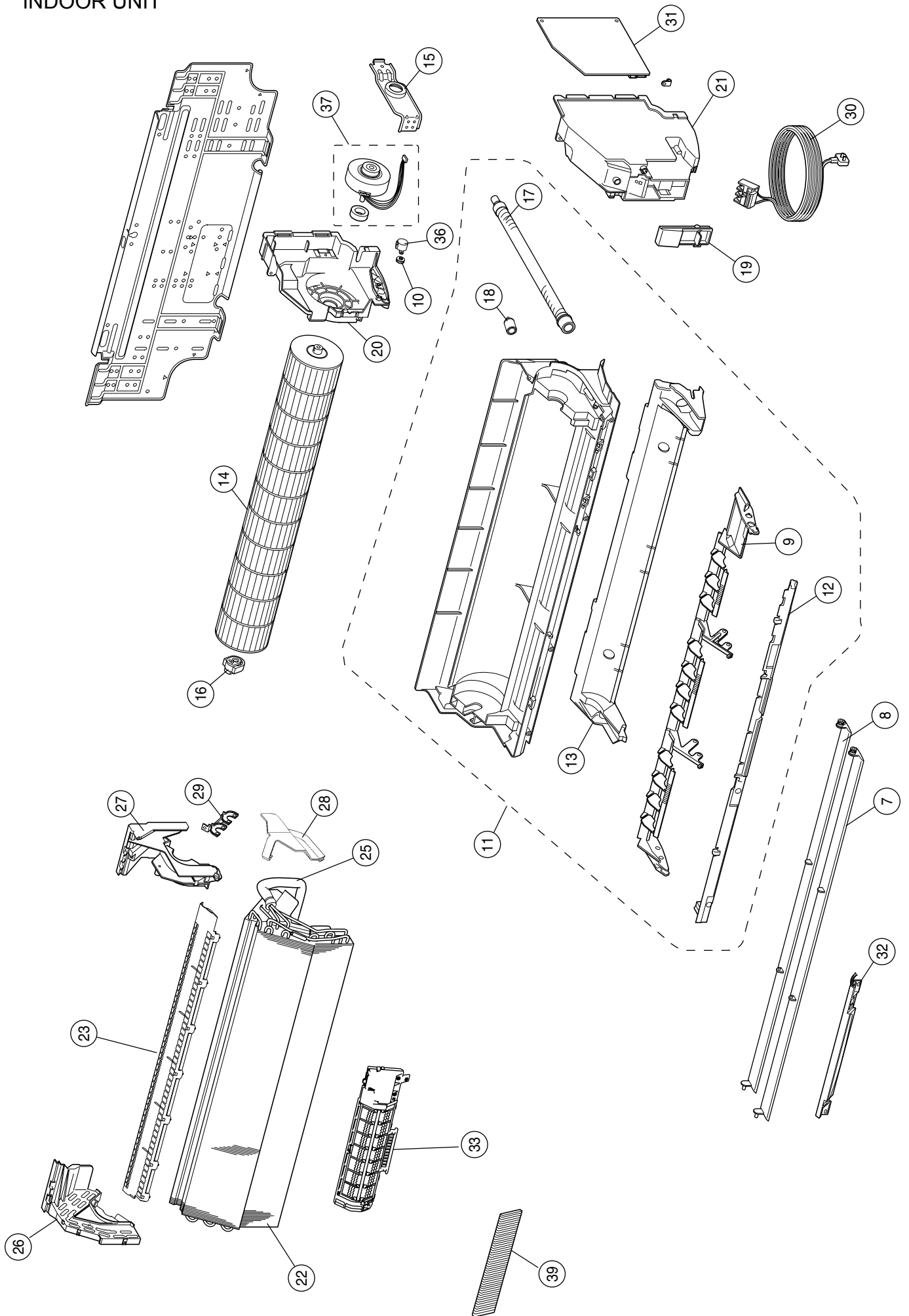

OUTDOOR UNIT

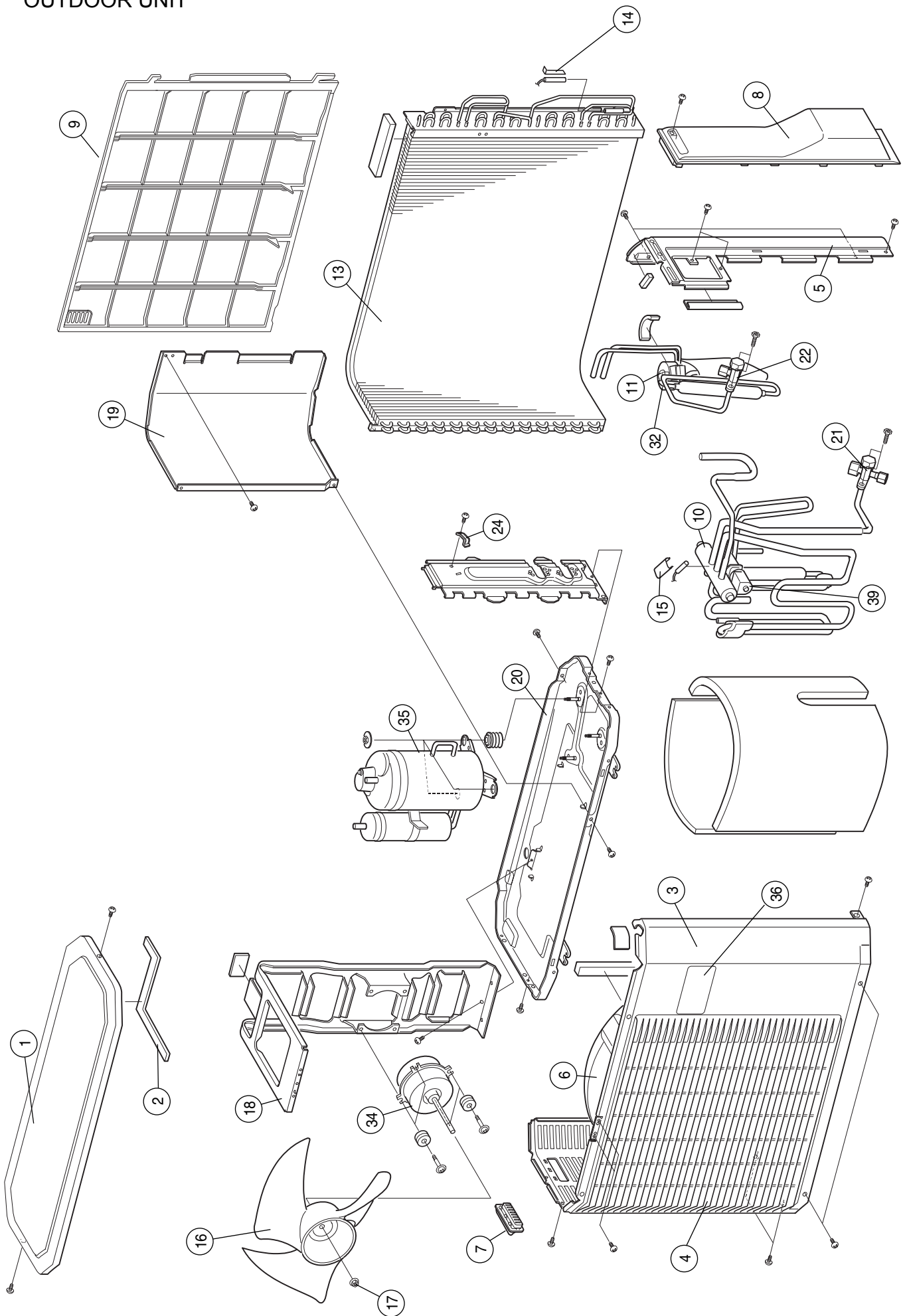

OUTDOOR UNIT

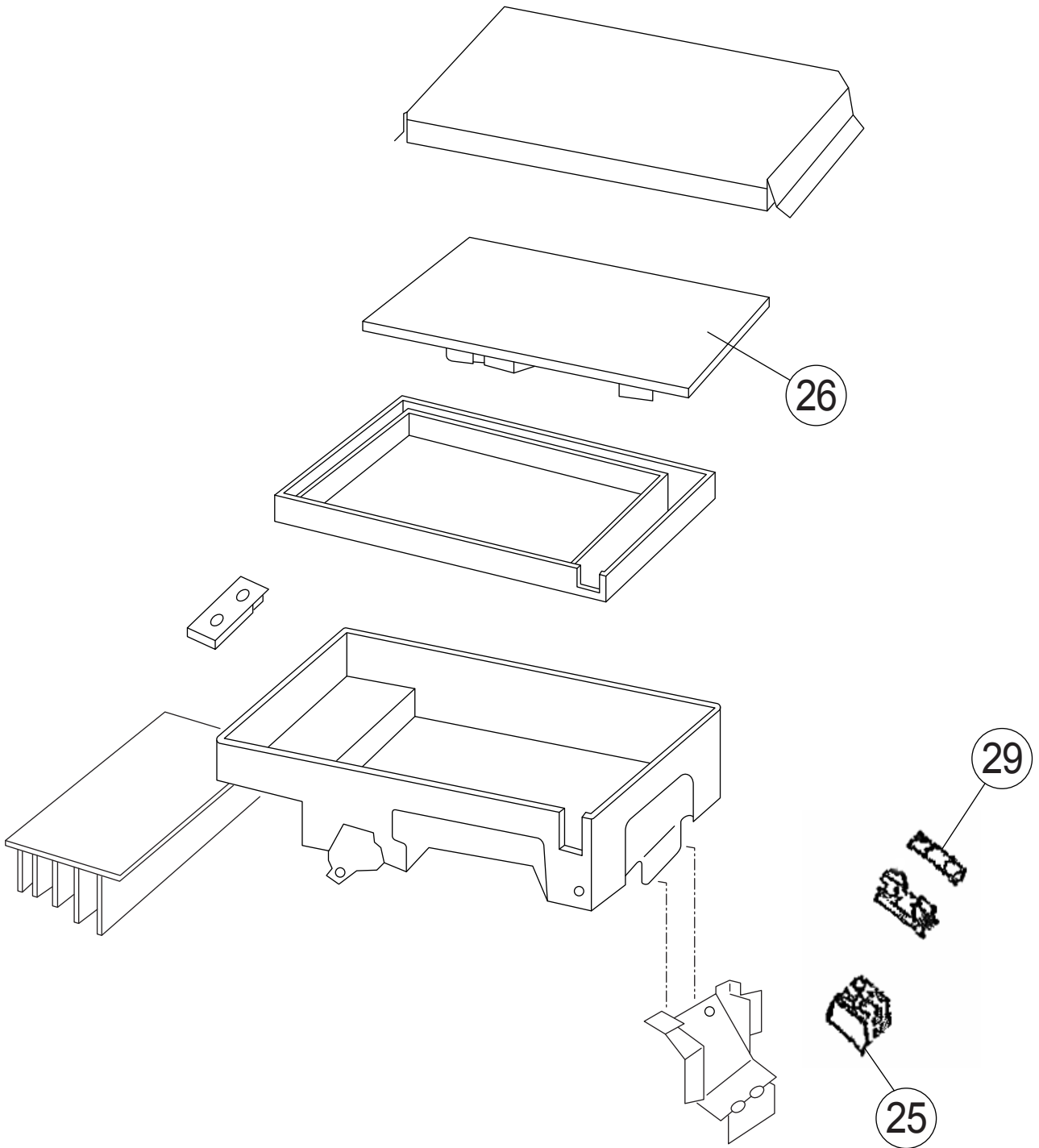

PARTS LIST







INDOOR UNIT

Ref. No.	Description	Part No.	Ord.
		RSB18LDC	Q'ty
1	Air Filter-L	9312920013	
2	Air Filter-R	9312921010	
3	Front Panel	9312914029	
4	Top Grill	9313948016	
5	Intake Grille Assy	9313157098	
6	Intake grill Clamp	9306755010	
7	Louver-U	9309991033	
8	Louver-Z	9309992030	
9	Louver Holder Assy	9309993013	
10	Gear A	9309994003	
11	Casing Assy	9311354079	
12	Casing Cover F	9309987005	
13	Casing Cover B	9314160011	
14	Crossflow Fan Assy	9307836015	
15	Clamper (Motor)	9310102008	
16	Bearing-C Assy	9306628017	
17	Drain Hose Assy	9314147012	
18	Drain Cap Assy	9314493010	
19	Wire Clamper	9311946014	
20	Box Switch	9312908011	
21	Cover (Switch)	9312909018	
22	Evaporator Total Assy	9313099015	
23	Filter Guide	9313920012	
25	H-Insulation (Pipe)-E	9304607007	
26	Evaporator Holder-L Assy	9313174019	
27	Evaporator Holder-R	9309983014	
28	Water Seal	9312912018	
29	Bracket (Evaporator)	9310464007	
30	Power Cord Assy	9900339012	
31	Controller PCB Assy	9707375015	
32	Indicator PCB Assy	9705375024	
33	Air Cleaner Assy	9313148041	
36	Motor, Step	9900139025	
37	Fan Motor, Brushless DC	9602109012	
38	Remote Control Unit Assy	9315027047	
39	Air Clean Filter	9313275013	
41	Remote Control Unit Holder	9305642045	
----	Room Temperature Thermistor	9700801108	
----	Pipe Temperature Thermistor	9702039042	
----	Transformer, Switch T1	9705054011	
----	Varister VA1	0000785020	
----	Fuse FSL 250 3.15(EM)	0600376062	
----	Fuse Holder FH1-FH2	0500158072	
----	Relay DW12D1 K1	9704185013	
----	Manual Auto Switch SW1	9703476013	
----	Evaporator B Assy	9311275022	

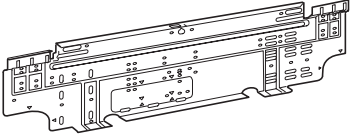
OUTDOOR UNIT

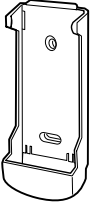
Ref. No.	Description	Part No.	Ord. Q'ty
		ROS18LDC	
1	Top Panel Assy	9309230057	
2	Top Panel Seal	9309228016	
3	Cabinet Assy	9314809040	
4	Blow Down Grille	9308884015	
5	Cabinet Right Assy	9309236011	
6	Fan Ring	9308885012	
7	Grip	9308880017	
8	Switch Cover	9308882028	
9	Protective Net	9315319012	
10	4-Way Valve Assy	9315726018	
11	Expansion Valve Assy	9311641018	
13	Condenser	9311381037	
14	Thermistor Spring-A	313728262708	
15	Thermistor Spring	9300089012	
16	Propeller Fan	9309909014	
17	Nut	9304902003	
18	Motor Bracket	9308872012	
19	Separator Assy	9312971015	
20	Base Assy, Painted	9308869081	
21	3-Way Valve Assy	9315159014	
22	2-Way Valve Assy	9313064013	
24	Cord Clamp	9307271014	
25	Terminal	9306489038	
26	Inverter PCB Assy	9707039153	
29	Fuse	0600382018	
32	Expansion Valve Coil	9900057039	
34	Fan Motor	9601725015	
35	Compressor Assy	9313764012	
36	Emblem	9312637034	
39	Solenoid Coil	9970033018	
---	IPM	9705720015	
---	Thermistor Assy	9900148027	
---	Outdoor Temp. Thermistor	9900210045	

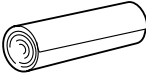
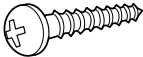
STANDARD ACCESSORIES

Name and Shape	Part No.
Wall hook bracket 	9310001004
Remote control unit 	9315027047
Remote control unit holder 	9305642045
Battery (penlight) 	0600185527
Cloth tape 	9310519004
Tapping screw (big) (φ 4 x 25) 	0700076046
Tapping screw (small) (φ 3 x 12) 	0700019036

0606G3097